



Choose Scandinavian trust

Wireless test report – 378820-1TRFWL

Type of assessment:

Original Certification

Applicant:

RADWIN Ltd.

Description of product as marketed:

Television Band Device (TVBD)

Model:

TVWS BS EXT

Model variant:

RW-5PG5-02WS

FCC ID:

Q3K-500TVWSBS

Test Standard Specification:

◆ **FCC 47 CFR Part 15 Subpart H – RF testing only**

Television Band Devices

Date of issue: December 10, 2019

Andrey Adelberg, Senior Wireless/EMC Specialist

Test engineer(s)

Kevin Rose, Wireless/EMC Specialist

Reviewed by

Signature

Signature





Test location

Company name	Nemko Canada Inc.
Facility Name	Ottawa
Address	303 River Road
City	Ottawa
Province	ON
Postal code	K1V 1H2
Country	Canada
Telephone	+1 613 737 9680
Facsimile	+1 613 737 9691
Toll free	+1 800 563 6336
Website	www.nemko.com
Site number	FCC: CA2040; (3 m semi anechoic chamber)

Limits of responsibility

Note that the results contained in this report relate only to the items tested and were obtained in the period between the date of initial receipt of samples and the date of issue of the report.

This test report has been completed in accordance with the requirements of ISO/IEC 17025. All results contain in this report are within Nemko Canada's ISO/IEC 17025 accreditation.

Copyright notification

Nemko Canada Inc. authorizes the applicant to reproduce this report provided it is reproduced in its entirety and for use by the company's employees only. Any use which a third party makes of this report, or any reliance on or decisions to be made based on it, are the responsibility of such third parties.

Nemko Canada Inc. accepts no responsibility for damages, if any, suffered by any third party as a result of decisions made or actions based on this report.

© Nemko Canada Inc.



Table of contents

Table of contents	3
Section 1. Report summary	4
1.1 Applicant and manufacturer	4
1.2 Test standard specification.....	4
1.3 Test procedures.....	4
1.4 Statement of compliance	4
1.5 Exclusions.....	4
1.6 Test report revision history	4
Section 2. Summary of test results	5
2.1 FCC Part 15, general requirements test results	5
2.2 FCC Part 15 Subpart H, test results.....	5
Section 3. Equipment under test (EUT) details	6
3.1 Sample information.....	6
3.2 EUT information	6
3.3 Technical information	6
3.4 Product description and theory of operation	6
3.5 EUT exercise details.....	6
3.6 EUT setup diagram	7
Section 4. Engineering considerations	8
4.1 Modifications incorporated in the EUT.....	8
4.2 Technical judgment	8
4.3 Deviations from laboratory tests procedures	8
Section 5. Test conditions	9
5.1 Atmospheric conditions	9
5.2 Power supply range.....	9
Section 6. Measurement uncertainty	10
6.1 Uncertainty of measurement	10
Section 7. Test equipment	11
7.1 Test equipment list.....	11
Section 8. Testing data	12
8.1 FCC 15.31(e) Variation of power source	12
8.2 FCC 15.31(m) Number of frequencies	13
8.3 FCC 15.203 Antenna requirement	14
8.4 FCC 15.207(a) AC power line conducted emissions limits	15
8.5 ANSI C63.10 6.9.3 Occupied bandwidth	18
8.6 FCC 15.709(b)(ii) Maximum conducted output power for fixed TVBDs.....	20
8.7 FCC 15.709(b)(ii) The power spectral density from the TVBD	25
8.8 FCC 15.709(d) Transmitter band edge and adjacent channel power for fixed TVBDs	29
8.9 FCC 15.709(d)(2) Radiated spurious emissions beyond the television channels	35
Section 9. Block diagrams and photos of test set-ups	38
9.1 Radiated emissions set-up for frequencies below 1 GHz.....	38
9.2 Radiated emissions set-up for frequencies above 1 GHz.....	39
9.3 Conducted emissions set-up	39

Section 1. Report summary

1.1 Applicant and manufacturer

Company name	RADWIN Ltd.
Address	27 Habarzel Street
City	Tel Aviv
Province/State	–
Postal/Zip code	6971039
Country	Israel

1.2 Test standard specification

Code of Federal Regulations (CFR)

Title	47	Telecommunication
Chapter	I	Federal Communications Commission (FCC)
Subchapter	A	General
Part	15	Radio Frequency Devices
Subparts	C	Intentional Radiators
	H	White Space Devices

1.3 Test procedures

416721 D01 White Space Test Procedures v02	Certification Test Procedures for TV Band (White Space) Devices Authorized Under Subpart H of the Part 15 Rules
ANSI C63.10 v2013	American National Standard of Procedures for Compliance Testing of Unlicensed Wireless Devices

1.4 Statement of compliance

In the configuration tested, the EUT was found compliant.

Testing was performed against all relevant requirements of the test standard except as noted in section 1.5 below. Results obtained indicate that the product under test complies in full with the requirements tested. The test results relate only to the items tested.

See “Summary of test results” for full details.

1.5 Exclusions

None

1.6 Test report revision history

Revision #	Date of issue	Details of changes made to test report
TRF	December 10, 2019	Original report issued

Section 2. Summary of test results

2.1 FCC Part 15, general requirements test results

Part	Test description	Verdict
§15.207(a)	Conducted limits	Pass
§15.31(e)	Variation of power source	Pass
§15.31(m)	Number of tested frequencies	Pass
§15.203	Antenna requirement	Pass

Notes: EUT is an AC powered device.

2.2 FCC Part 15 Subpart H, test results

Part	Test description	Verdict
§15.709(b)(ii)	Maximum conducted output power for fixed TVBDs	Pass
§15.709(b)(ii)	Power spectral density for fixed TVBDs	Pass
§15.709(d)	Adjacent channel power for fixed TVBDs	Pass
§15.709(d)	Radiated spurious emissions outside TV bands	Pass
§15.709(c)(4)	AC power line conducted limits	Pass

Note: none

Section 3. Equipment under test (EUT) details

3.1 Sample information

Receipt date	October 14, 2019
Nemko sample ID number	1

3.2 EUT information

Product name	Television Band Device (TVBD)
Model	TVWS BS EXT
Model variants	RW-5PG5-02WS
Serial number	Prototype

3.3 Technical information

Operating band	470–698 MHz (channels 14–51)
Operating frequency*	473–695 MHz
Modulation type	BPSK, QPSK, 16-QAM, 64-QAM, 256-QAM
Channel bandwidth	6, 12, 24 MHz
Emission designator	W7W
Power requirements	56 V _{DC} from PoE: 120 V _{AC} 60 Hz
Antenna information	12.8 dBi External Dual Polarized Base Station Antenna RADWIN PN: RW-9061-0407

Note: * see section 8.2 for detailed channel frequencies.

3.4 Product description and theory of operation

The TVWS base station is a small and compact outdoor unit that transmits two independent carriers. Each carrier provides up to 150Mbps by bonding 4 contiguous TVWS channels. The base station is deployed with an external MIMO 2x2 antenna. It is connected to the network through a GbE POE or SFP with DC input. The base station includes an embedded GPS with an integrated antenna or optional external antenna. The base station main features include up to 300Mbps (2 x 150Mbps) throughput, up to 256 QAM modulation rates in 6, 12, 24 MHz channel bandwidths, support of up to 64 subscribers.

3.5 EUT exercise details

The EUT was powered from a PoE. During the tests a laptop was used to connect to the EUT and configure the device to transmit continuously with the desired modulation and power.

All conducted measurements were with the MIMO TX version as the worst case. The EUT was tested with the appropriate antennas for spurious and conducted emissions to ensure the enclosure variation did not have impact.

3.6 EUT setup diagram

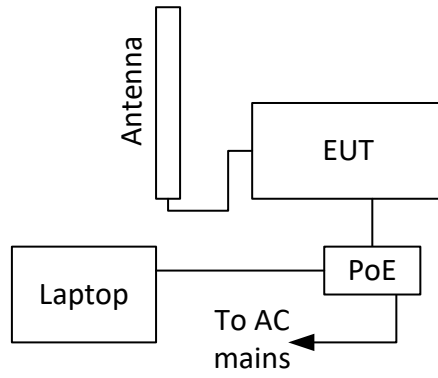

Figure 3.6-1: Setup diagram

Section 4. Engineering considerations

4.1 Modifications incorporated in the EUT

There were no modifications performed to the EUT during this assessment.

4.2 Technical judgment

None

4.3 Deviations from laboratory tests procedures

No deviations were made from laboratory procedures.

Section 5. Test conditions

5.1 Atmospheric conditions

Temperature	15–30 °C
Relative humidity	20–75 %
Air pressure	860–1060 mbar

When it is impracticable to carry out tests under these conditions, a note to this effect stating the ambient temperature and relative humidity during the tests shall be recorded and stated.

5.2 Power supply range

The normal test voltage for equipment to be connected to the mains shall be the nominal mains voltage. For the purpose of the present document, the nominal voltage shall be the declared voltage, or any of the declared voltages $\pm 5\%$, for which the equipment was designed.

Section 6. Measurement uncertainty

6.1 Uncertainty of measurement

Measurement uncertainty budgets for the tests are detailed below. Measurement uncertainty calculations assume a coverage factor of $K = 2$ with 95% certainty.

Test name	Measurement uncertainty, dB
All antenna port measurements	0.55
Conducted spurious emissions	1.13
Radiated spurious emissions	3.78
AC power line conducted emissions	3.55

Section 7. Test equipment

7.1 Test equipment list

Table 7.1-1: Equipment list

Equipment	Manufacturer	Model no.	Asset no.	Cal cycle	Next cal.
3 m EMI test chamber	TDK	SAC-3	FA002047	1 year	January 24, 2020
Flush mount turntable	Sunol	FM2022	FA002082	—	NCR
Controller	Sunol	SC104V	FA002060	—	NCR
Antenna mast	Sunol	TLT2	FA002061	—	NCR
61505 AC source	Chroma	61509	FA003036	—	VOU
Receiver/spectrum analyzer	Rohde & Schwarz	ESU 26	FA002043	1 year	May 8, 2020
Spectrum analyzer	Rohde & Schwarz	FSU	FA001877	1 year	October 31, 2020
Horn (1–18 GHz)	ETS Lindgren	3117	FA002840	1 year	January 16, 2020
Preamp (1–18 GHz)	ETS Lindgren	124334	FA002873	1 year	November 4, 2020
Bilog antenna (20–3000 MHz)	Sunol	JB3	FA002108	1 year	January 3, 2020
Horn antenna (1–18 GHz)	EMCO	3115	FA000825	1 year	October 31, 2020
LISN	Rohde & Schwarz	ENV216	FA002515	1 year	July 18, 2020

Note: NCR - no calibration required, VOU - verify on use



Section 8. Testing data

8.1 FCC 15.31(e) Variation of power source

8.1.1 Definitions and limits

For intentional radiators, measurements of the variation of the input power or the radiated signal level of the fundamental frequency component of the emission, as appropriate, shall be performed with the supply voltage varied between 85% and 115% of the nominal rated supply voltage. For battery operated equipment, the equipment tests shall be performed using a new battery.

8.1.2 Test date

Start date

8.1.3 Observations, settings and special notes

EUT input is 56 V_{DC} from the PoE power supply.

8.1.4 Test data

EUT Power requirements: AC DC Battery
If EUT is an AC or a DC powered, was the noticeable output power variation observed? YES NO N/A
If EUT is battery operated, was the testing performed using fresh batteries? YES NO N/A
If EUT is rechargeable battery operated, was the testing performed using fully charged batteries? YES NO N/A



8.2 FCC 15.31(m) Number of frequencies

8.2.1 Definitions and limits

Measurements on intentional radiators or receivers shall be performed and, if required, reported for each band in which the device can be operated with the device operating at the number of frequencies in each band specified in the following table.

Table 8.2-1: Frequency Range of Operation

Frequency range over which the device operates (in each band)	Number of test frequencies required	Location of measurement frequency inside the operating frequency range
1 MHz or less	1	Center (middle of the band)
1–10 MHz	2	1 near high end, 1 near low end
Greater than 10 MHz	3	1 near high end, 1 near center and 1 near low end

Note: "near" means as close as possible to or at the centre / low end / high end of the frequency range over which the device operates.

8.2.2 Test date

Start date October 15, 2019

8.2.3 Observations, settings and special notes

None

8.2.4 Test data

Table 8.2-2: Test channels frequencies selection

Start of Frequency range, MHz	End of Frequency range, MHz	Frequency range bandwidth, MHz	Channel size, MHz	Low channel, MHz	Mid channel, MHz	High channel, MHz
470	698	228	6	473	587	695
			12	476	584	692
			24	482	584	686



8.3 FCC 15.203 Antenna requirement

8.3.1 Definitions and limits

An intentional radiator shall be designed to ensure that no antenna other than that furnished by the responsible party shall be used with the device. The use of a permanently attached antenna or of an antenna that uses a unique coupling to the intentional radiator shall be considered sufficient to comply with the provisions of this section. The manufacturer may design the unit so that a broken antenna can be replaced by the user, but the use of a standard antenna jack or electrical connector is prohibited. This requirement does not apply to intentional radiators that must be professionally installed, such as perimeter protection systems and some field disturbance sensors, or to other intentional radiators which, in accordance with §15.31(d), must be measured at the installation site. However, the installer shall be responsible for ensuring that the proper antenna is employed so that the limits in this part are not exceeded.

8.3.2 Test date

Start date October 15, 2019

8.3.3 Observations, settings and special notes

None

8.3.4 Test data

Must the EUT be professionally installed? YES NO
Does the EUT have detachable antenna(s)? YES NO
 If detachable, is the antenna connector(s) non-standard? YES NO N/A

8.4 FCC 15.207(a) AC power line conducted emissions limits

8.4.1 Definitions and limits

FCC 15.709(c)(4):

White space devices connected to the AC power line are required to comply with the conducted limits set forth in §15.207.

FCC 15.207(a):

Except as shown in paragraphs (b) and (c) of this section, for an intentional radiator that is designed to be connected to the public utility (AC) power line, the radio frequency voltage that is conducted back onto the AC power line on any frequency or frequencies, within the band 150 kHz to 30 MHz, shall not exceed the limits in the following table, as measured using a 50 μH/50 Ω line impedance stabilization network (LISN). Compliance with the provisions of this paragraph shall be based on the measurement of the radio frequency voltage between each power line and ground at the power terminal. The lower limit applies at the boundary between the frequency ranges.

Table 8.4-1: Conducted emissions limit

Frequency of emission, MHz	Conducted limit, dBμV	
	Quasi-peak	Average**
0.15–0.5	66 to 56*	56 to 46*
0.5–5	56	46
5–30	60	50

Note: * - The level decreases linearly with the logarithm of the frequency.

** - A linear average detector is required.

8.4.2 Test date

Start date October 24, 2019

8.4.3 Observations, settings and special notes

The EUT was set up as tabletop configuration.

The spectral scan has been corrected with transducer factors (i.e. cable loss, LISN factors, and attenuators) for determination of compliance.

A preview measurement was generated with the receiver in continuous scan mode. Emissions detected within 6 dB or above limit were re-measured with the appropriate detector against the correlating limit and recorded as the final measurement.

Receiver settings:

	Preview measurements	Final measurements
Resolution bandwidth	9 kHz	9 kHz
Video bandwidth	30 kHz	30 kHz
Detector mode	Peak and Average	Quasi-Peak and Average
Trace mode	Max Hold	Max Hold
Measurement time	1000 ms	1000 ms

8.4.4 Test data

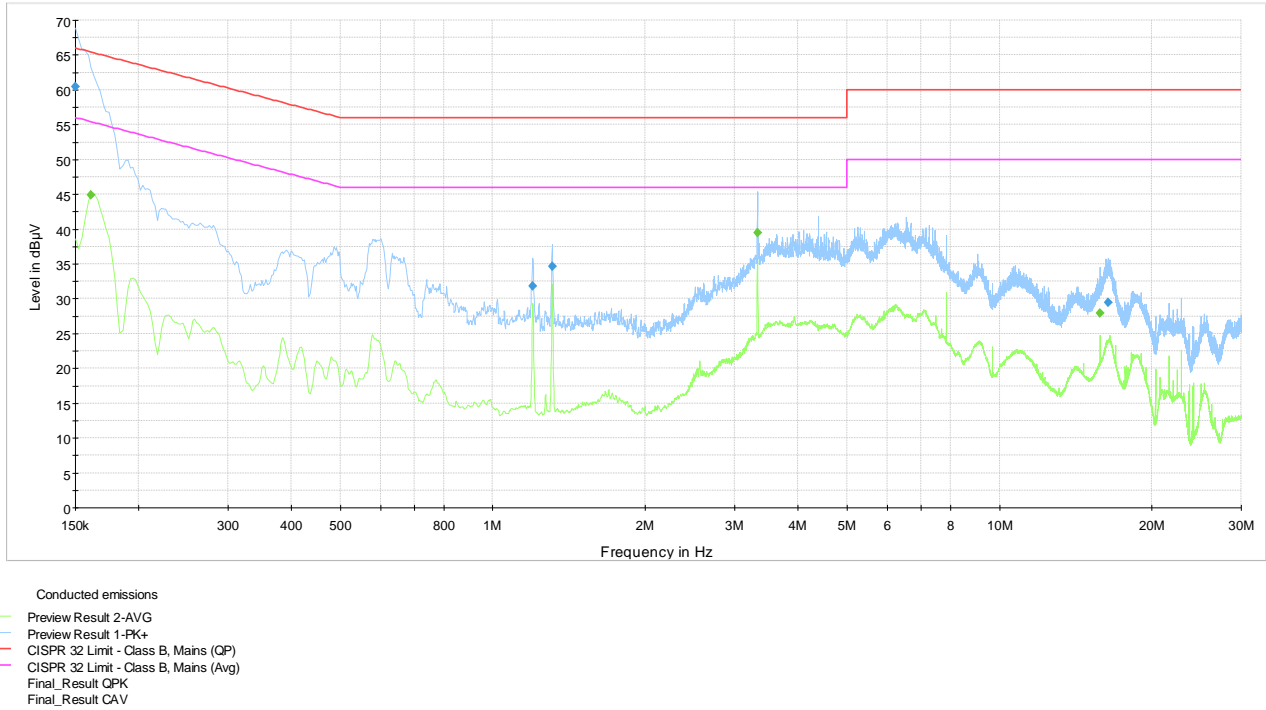

Plot 8.4-1: Conducted emissions on phase line

Table 8.4-2: Quasi-peak measurement results for phase line

Frequency, MHz	Quasi-Peak, dBµV/m	Quasi-Peak limit, dBµV/m	Margin, dB	Correction factor, dB
0.150000	60.41	66.00	5.59	9.80
1.200750	31.81	56.00	24.19	9.80
1.308750	34.62	56.00	21.38	9.80
16.385500	29.49	60.00	30.51	10.60

Table 8.4-3: Average measurement results for phase line

Frequency, MHz	Average, dBµV/m	Average limit, dBµV/m	Margin, dB	Correction factor, dB
0.161250	44.90	55.40	10.50	10.00
3.329250	39.52	46.00	6.48	9.90
15.769000	27.93	50.00	22.07	10.50

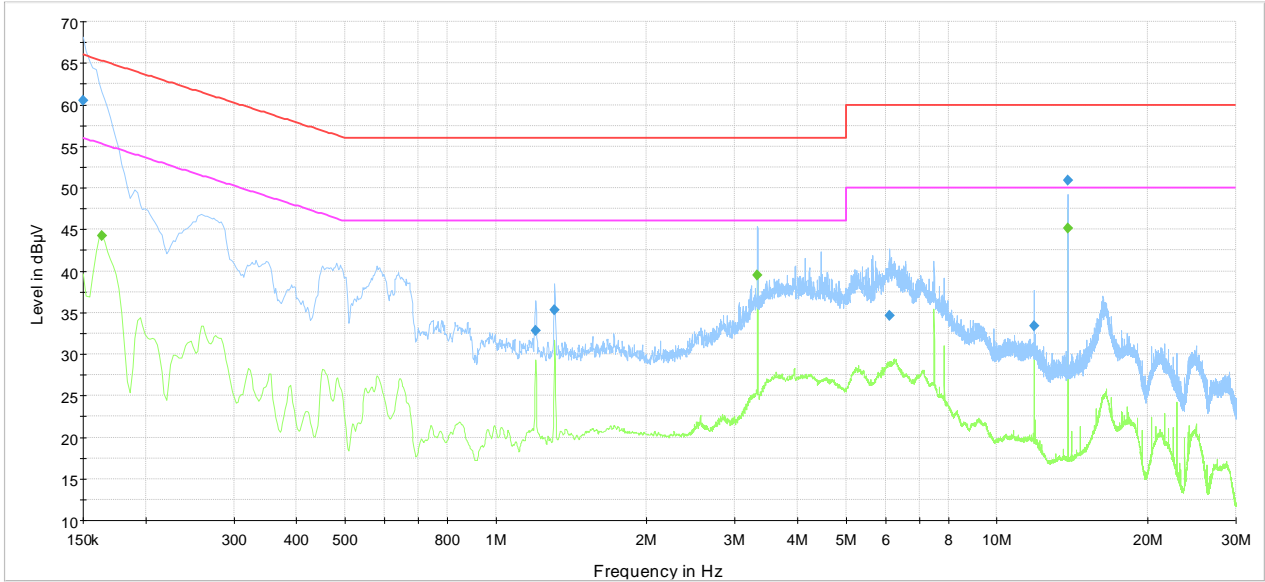

- Conducted emissions
- Preview Result 2-AVG
- Preview Result 1-PK+
- CISPR 32 Limit - Class B, Mains (QP)
- CISPR 32 Limit - Class B, Mains (Avg)
- Final_Result QPK
- Final_Result CAV

Plot 8.4-2: Conducted emissions on neutral line

Table 8.4-4: Quasi-peak measurement results for neutral line

Frequency, MHz	Quasi-Peak, dBµV/m	Quasi-Peak limit, dBµV/m	Margin, dB	Correction factor, dB
0.150000	60.53	66.00	5.47	9.80
1.200750	32.77	56.00	23.23	9.80
1.311000	35.31	56.00	20.69	9.80
6.114750	34.66	60.00	25.34	10.10
11.858500	33.43	60.00	26.57	10.50
13.845250	50.90	60.00	9.10	10.50

Table 8.4-5: Average measurement results for neutral line

Frequency, MHz	Average, dBµV/m	Average limit, dBµV/m	Margin, dB	Correction factor, dB
0.163500	44.22	55.28	11.06	10.00
3.329250	39.51	46.00	6.49	9.90
13.845250	45.19	50.00	4.81	10.50



8.5 ANSI C63.10 6.9.3 Occupied bandwidth

8.5.1 Definitions and limits

The occupied bandwidth or the “99% emission bandwidth” is defined as the frequency range between two points, one above and the other below the carrier frequency, within which 99% of the total transmitted power of the fundamental transmitted emission is contained.

8.5.2 Test date

Start date October 16, 2019

8.5.3 Observations, settings and special notes

There is no 99% occupied bandwidth limit in the standard’s requirements, the measurement results provided for information purposes only.
 Spectrum analyzer settings:

Detector mode	Peak
Resolution bandwidth	1% to 5% of the OBW
Video bandwidth	RBW × 3
Trace mode	Max Hold

8.5.4 Test data

Table 8.5-1: 99% occupied bandwidth verification results

Channel bandwidth, MHz	Antenna port	Frequency, MHz	99% occupied bandwidth, MHz
6	1	473	4.439
6	2	473	4.455
6	1	587	4.439
6	2	587	4.439
6	1	695	4.439
6	2	695	4.439
12	1	476	8.878
12	2	476	8.878
12	1	584	8.910
12	2	584	8.878
12	1	692	8.910
12	2	692	8.878
24	1	482	17.708
24	2	482	17.788
24	1	584	17.788
24	2	584	17.788
24	1	686	17.708
24	2	686	17.708

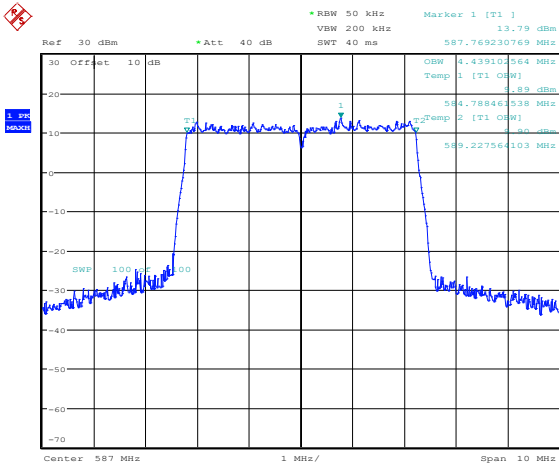

Date: 16.OCT.2019 15:20:34

Figure 8.5-1: Occupied bandwidth, sample plot for 6 MHz channel

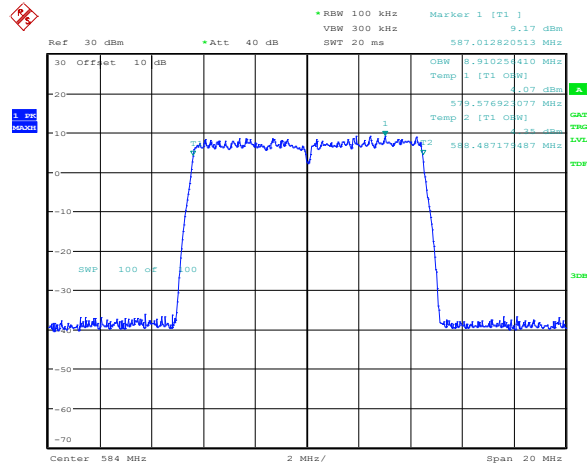

Date: 16.OCT.2019 15:30:22

Figure 8.5-2: Occupied bandwidth, sample plot for 12 MHz channel

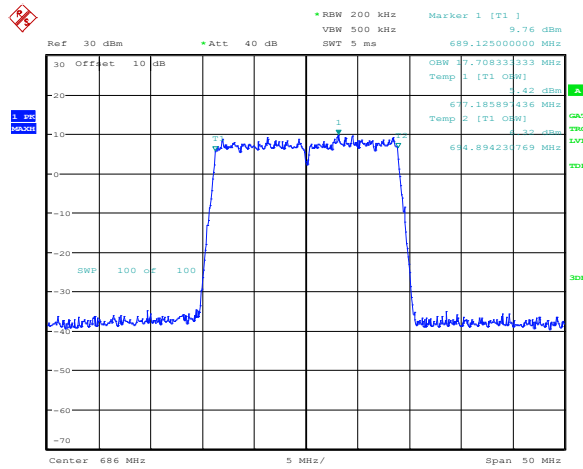

Date: 16.OCT.2019 15:46:46

Figure 8.5-3: Occupied bandwidth, sample plot for 24 MHz channel



8.6 FCC 15.709(b)(ii) Maximum conducted output power for fixed TVBDs

8.6.1 Definitions and limits

For fixed TVBDs, the maximum power delivered to the transmitting antenna shall not exceed one watt per 6 megahertz of bandwidth on which the device operates. The power delivered to the transmitting antenna is the maximum conducted output power reduced by the signal loss experienced in the cable used to connect the transmitter to the transmit antenna. The maximum gain of the transmitting antenna used with a Fixed WSD must be declared by the manufacturer in the certification application. If the transmitting antenna gain exceeds 6 dBi (or 10 dBi in less congested areas) for fixed white space device operating at up to 36 dBm (or 40 dBm in less congested areas) EIRP, the conducted output power limit shall all be reduced by the amount in dB by which the gain exceeds 6 dBi (or 10 dBi in less congested areas).

8.6.2 Test date

Start date October 15, 2019

8.6.3 Observations, settings and special notes

The power integration per antenna port for “conducted total transmit power” was performed over 12 MHz and 24 MHz channel bandwidth for information purposes only.

Antenna gain is 12.8 dBi with 0.3 dB cable loss, therefore the net system uncorrelated gain is 12.5 dBi

Conducted output power limits calculation.

- For operation within congested areas: 12.5 dBi > 6 dBi therefore 6.5 dB reduction in output power limit was required.
Limit per 6 MHz is 30 dBm – 6.5 dB = 23.5 dBm
- For operation within non-congested areas: 12.5 dBi > 10 dBi therefore 2.5 dB reduction in output power limit was required.
Limit per 6 MHz is 30 dBm – 2.5 dB = 27.5 dBm

Spectrum analyser settings for output power:

Resolution bandwidth:	100 kHz
Video bandwidth:	300 kHz
Detector mode:	RMS
Trace mode:	Power Averaging over 100 traces
Integration bandwidth:	6 MHz



8.6.4 Test data

Table 8.6-1: Conducted output power and EIRP measurements for *single carrier* operation within congested areas

(BW) Channel	Antenna port	Frequency, MHz	Power, dBm/6 MHz	Power limit, dBm/6 MHz	Margin, dB	Antenna gain, dBi	EIRP, dBm/6 MHz	EIRP limit, dBm/6 MHz	Margin, dB
(6 MHz) Low	1	473	20.20	23.50	3.30	12.50	32.70	36.00	3.30
(6 MHz) Mid	1	587	21.06	23.50	2.44	12.50	33.56	36.00	2.44
(6 MHz) High	1	695	20.62	23.50	2.88	12.50	33.12	36.00	2.88
(6 MHz) Low	2	473	20.00	23.50	3.50	12.50	32.50	36.00	3.50
(6 MHz) Mid	2	587	19.92	23.50	3.58	12.50	32.42	36.00	3.58
(6 MHz) High	2	695	20.93	23.50	2.57	12.50	33.43	36.00	2.57
(12 MHz) Low	1	476	19.19	23.50	4.31	12.50	31.69	36.00	4.31
(12 MHz) Mid	1	584	20.48	23.50	3.02	12.50	32.98	36.00	3.02
(12 MHz) High	1	692	20.3	23.50	3.20	12.50	32.80	36.00	3.20
(12 MHz) Low	2	476	19.52	23.50	3.98	12.50	32.02	36.00	3.98
(12 MHz) Mid	2	584	21.31	23.50	2.19	12.50	33.81	36.00	2.19
(12 MHz) High	2	692	20.46	23.50	3.04	12.50	32.96	36.00	3.04
(24 MHz) Low	1	482	16.51	23.50	6.99	12.50	29.01	36.00	6.99
(24 MHz) Mid	1	584	18.41	23.50	5.09	12.50	30.91	36.00	5.09
(24 MHz) High	1	686	18.00	23.50	5.50	12.50	30.50	36.00	5.50
(24 MHz) Low	2	482	16.91	23.50	6.59	12.50	29.41	36.00	6.59
(24 MHz) Mid	2	584	19.33	23.50	4.17	12.50	31.83	36.00	4.17
(24 MHz) High	2	686	18.20	23.50	5.30	12.50	30.70	36.00	5.30

Table 8.6-2: Conducted output power and EIRP measurements for *single carrier* operation within less congested areas

(BW) Channel	Antenna port	Frequency, MHz	Power, dBm/6 MHz	Power limit, dBm/6 MHz	Margin, dB	Antenna gain, dBi	EIRP, dBm/6 MHz	EIRP limit, dBm/6 MHz	Margin, dB
(6 MHz) Low	1	473	21.59	27.50	5.91	12.50	34.09	40.00	5.91
(6 MHz) Mid	1	587	21.34	27.50	6.16	12.50	33.84	40.00	6.16
(6 MHz) High	1	695	21.28	27.50	6.22	12.50	33.78	40.00	6.22
(6 MHz) Low	2	473	21.06	27.50	6.44	12.50	33.56	40.00	6.44
(6 MHz) Mid	2	587	21.67	27.50	5.83	12.50	34.17	40.00	5.83
(6 MHz) High	2	695	21.32	27.50	6.18	12.50	33.82	40.00	6.18
(12 MHz) Low	1	476	19.77	27.50	7.73	12.50	32.27	40.00	7.73
(12 MHz) Mid	1	584	20.83	27.50	6.67	12.50	33.33	40.00	6.67
(12 MHz) High	1	692	20.32	27.50	7.18	12.50	32.82	40.00	7.18
(12 MHz) Low	2	476	20.46	27.50	7.04	12.50	32.96	40.00	7.04
(12 MHz) Mid	2	584	21.52	27.50	5.98	12.50	34.02	40.00	5.98
(12 MHz) High	2	692	20.57	27.50	6.93	12.50	33.07	40.00	6.93
(24 MHz) Low	1	482	17.78	27.50	9.72	12.50	30.28	40.00	9.72
(24 MHz) Mid	1	584	19.00	27.50	8.50	12.50	31.50	40.00	8.50
(24 MHz) High	1	686	18.66	27.50	8.84	12.50	31.16	40.00	8.84
(24 MHz) Low	2	482	17.39	27.50	10.11	12.50	29.89	40.00	10.11
(24 MHz) Mid	2	584	19.85	27.50	7.65	12.50	32.35	40.00	7.65
(24 MHz) High	2	686	19.07	27.50	8.43	12.50	31.57	40.00	8.43



Table 8.6-3: Conducted output power and EIRP measurements for *multi carrier* operation within congested areas

(BW) Channels	Antenna port	Frequencies, MHz	Power, dBm/6 MHz	Power limit, dBm/6 MHz	Margin, dB	Antenna gain, dBi	EIRP, dBm/6 MHz	EIRP limit, dBm/6 MHz	Margin, dB
(6 MHz) 2 × Low	1	473 + 479	18.14	23.50	5.36	12.50	30.64	36.00	5.36
(6 MHz) 2 × High	1	689 + 695	19.38	23.50	4.12	12.50	31.88	36.00	4.12
(6 MHz) 2 × Low	2	473 + 479	18.73	23.50	4.77	12.50	31.23	36.00	4.77
(6 MHz) 2 × High	2	689 + 695	18.72	23.50	4.78	12.50	31.22	36.00	4.78
(12 MHz) 2 × Low	1	476 + 488	17.39	23.50	6.11	12.50	29.89	36.00	6.11
(12 MHz) 2 × High	1	680 + 692	18.36	23.50	5.14	12.50	30.86	36.00	5.14
(12 MHz) 2 × Low	2	476 + 488	17.56	23.50	5.94	12.50	30.06	36.00	5.94
(12 MHz) 2 × High	2	680 + 692	17.28	23.50	6.22	12.50	29.78	36.00	6.22
(24 MHz) 2 × Low	1	482 + 506	15.40	23.50	8.10	12.50	27.90	36.00	8.10
(24 MHz) 2 × High	1	662 + 686	16.02	23.50	7.48	12.50	28.52	36.00	7.48
(24 MHz) 2 × Low	2	482 + 506	15.67	23.50	7.83	12.50	28.17	36.00	7.83
(24 MHz) 2 × High	2	662 + 686	16.57	23.50	6.93	12.50	29.07	36.00	6.93

Table 8.6-4: Conducted output power and EIRP measurements for *multi carrier* operation within less congested areas

(BW) Channels	Antenna port	Frequencies, MHz	Power, dBm/6 MHz	Power limit, dBm/6 MHz	Margin, dB	Antenna gain, dBi	EIRP, dBm/6 MHz	EIRP limit, dBm/6 MHz	Margin, dB
(6 MHz) 2 × Low	1	473 + 479	19.08	27.50	8.42	12.50	31.58	40.00	8.42
(6 MHz) 2 × High	1	689 + 695	19.66	27.50	7.84	12.50	32.16	40.00	7.84
(6 MHz) 2 × Low	2	473 + 479	19.78	27.50	7.72	12.50	32.28	40.00	7.72
(6 MHz) 2 × High	2	689 + 695	19.59	27.50	7.91	12.50	32.09	40.00	7.91
(12 MHz) 2 × Low	1	476 + 488	17.68	27.50	9.82	12.50	30.18	40.00	9.82
(12 MHz) 2 × High	1	680 + 692	19.00	27.50	8.50	12.50	31.50	40.00	8.50
(12 MHz) 2 × Low	2	476 + 488	18.01	27.50	9.49	12.50	30.51	40.00	9.49
(12 MHz) 2 × High	2	680 + 692	18.96	27.50	8.54	12.50	31.46	40.00	8.54
(24 MHz) 2 × Low	1	482 + 506	15.88	27.50	11.62	12.50	28.38	40.00	11.62
(24 MHz) 2 × High	1	662 + 686	16.99	27.50	10.51	12.50	29.49	40.00	10.51
(24 MHz) 2 × Low	2	482 + 506	16.23	27.50	11.27	12.50	28.73	40.00	11.27
(24 MHz) 2 × High	2	662 + 686	17.25	27.50	10.25	12.50	29.75	40.00	10.25



Table 8.6-5: Conducted total transmit output power for *single carrier* operation within congested areas

(BW) Channel	Antenna port	Frequency, MHz	Total Transmit Output Power, dBm	Total Transmit Output Power, W
(6 MHz) Low	1	473	20.20	0.105
(6 MHz) Mid	1	587	21.06	0.128
(6 MHz) High	1	695	20.62	0.115
(6 MHz) Low	2	473	20.00	0.100
(6 MHz) Mid	2	587	19.92	0.098
(6 MHz) High	2	695	20.93	0.124
(12 MHz) Low	1	476	20.98	0.125
(12 MHz) Mid	1	584	22.14	0.164
(12 MHz) High	1	692	21.94	0.156
(12 MHz) Low	2	476	21.34	0.136
(12 MHz) Mid	2	584	22.98	0.199
(12 MHz) High	2	692	22.13	0.163
(24 MHz) Low	1	482	21.08	0.128
(24 MHz) Mid	1	584	22.41	0.174
(24 MHz) High	1	686	22.35	0.172
(24 MHz) Low	2	482	21.42	0.139
(24 MHz) Mid	2	584	23.39	0.218
(24 MHz) High	2	686	22.61	0.182

Table 8.6-6: Conducted total transmit output power for *single carrier* operation within less congested areas

(BW) Channel	Antenna port	Frequency, MHz	Total Transmit Output Power, dBm	Total Transmit Output Power, W
(6 MHz) Low	1	473	21.59	0.144
(6 MHz) Mid	1	587	21.34	0.136
(6 MHz) High	1	695	21.28	0.134
(6 MHz) Low	2	473	21.06	0.128
(6 MHz) Mid	2	587	21.67	0.147
(6 MHz) High	2	695	21.32	0.136
(12 MHz) Low	1	476	21.69	0.148
(12 MHz) Mid	1	584	22.47	0.177
(12 MHz) High	1	692	22.03	0.160
(12 MHz) Low	2	476	22.33	0.171
(12 MHz) Mid	2	584	23.20	0.209
(12 MHz) High	2	692	22.37	0.173
(24 MHz) Low	1	482	22.05	0.160
(24 MHz) Mid	1	584	23.06	0.202
(24 MHz) High	1	686	22.48	0.177
(24 MHz) Low	2	482	22.34	0.171
(24 MHz) Mid	2	584	22.88	0.194
(24 MHz) High	2	686	22.96	0.198



Table 8.6-7: Conducted total transmit output power for *multi carrier* operation within congested areas

(BW) Channels	Antenna port	Frequencies, MHz	Total Transmit Output Power, dBm	Total Transmit Output Power, W
(6 MHz) 2 × Low	1	473 + 479	18.14	0.065
(6 MHz) 2 × High	1	689 + 695	19.38	0.087
(6 MHz) 2 × Low	2	473 + 479	18.73	0.075
(6 MHz) 2 × High	2	689 + 695	18.72	0.074
(12 MHz) 2 × Low	1	476 + 488	21.36	0.137
(12 MHz) 2 × High	1	680 + 692	22.49	0.177
(12 MHz) 2 × Low	2	476 + 488	21.53	0.142
(12 MHz) 2 × High	2	680 + 692	21.54	0.143
(24 MHz) 2 × Low	1	482 + 506	22.15	0.164
(24 MHz) 2 × High	1	662 + 686	22.83	0.192
(24 MHz) 2 × Low	2	482 + 506	22.37	0.173
(24 MHz) 2 × High	2	662 + 686	22.68	0.185

Table 8.6-8: Conducted total transmit output power for *multi carrier* operation within less congested areas

(BW) Channels	Antenna port	Frequencies, MHz	Total Transmit Output Power, dBm	Total Transmit Output Power, W
(6 MHz) 2 × Low	1	473 + 479	19.08	0.081
(6 MHz) 2 × High	1	689 + 695	19.66	0.092
(6 MHz) 2 × Low	2	473 + 479	19.78	0.095
(6 MHz) 2 × High	2	689 + 695	19.59	0.091
(12 MHz) 2 × Low	1	476 + 488	21.73	0.149
(12 MHz) 2 × High	1	680 + 692	23.63	0.231
(12 MHz) 2 × Low	2	476 + 488	22.12	0.163
(12 MHz) 2 × High	2	680 + 692	23.29	0.213
(24 MHz) 2 × Low	1	482 + 506	22.83	0.192
(24 MHz) 2 × High	1	662 + 686	24.09	0.256
(24 MHz) 2 × Low	2	482 + 506	23.11	0.205
(24 MHz) 2 × High	2	662 + 686	23.96	0.249



8.7 FCC 15.709(b)(ii) The power spectral density from the TVBD

8.7.1 Definitions and limits

The power spectral density from the TVBD shall not be greater than the following values when measured in any 100 kHz band during any time interval of continuous transmission:

Fixed devices with 36 dBm EIRP: 12.6 dBm/100 kHz conducted power density.

The PSD limits for fixed white space devices operating at up to 36 dBm (4000 milliwatts) (or 40 dBm (10 W) in less congested areas) are based on a maximum transmitting antenna gain of 6 dBi (or 10 dBi in less congested areas). If transmitting antennas of directional gain greater than 6 dBi are used, the maximum conducted output power shall be reduced by the amount in dB that the directional gain of the antenna exceeds 6 dBi (or 10 dBi in less congested areas).

8.7.2 Test date

Start date October 21, 2019

8.7.3 Observations, settings and special notes

Antenna gain is 12.8 dBi with 0.3 dB cable loss, therefore the net system uncorrelated gain is 12.5 dBi

PSD limits calculation.

- For operation within congested areas: 12.5 dBi > 6 dBi therefore 6.5 dB reduction in PSD limit was required.
Limit per 100 kHz is 12.6 dBm – 6.5 dB = 6.1 dBm
- For operation within non-congested areas: 12.5 dBi > 10 dBi therefore 2.5 dB reduction in PSD limit was required.
Limit per 100 kHz is 12.6 dBm – 2.5 dB = 10.1 dBm

Spectrum analyser settings for PSD:

Resolution bandwidth:	100 kHz
Video bandwidth:	300 kHz
Detector mode:	RMS
Trace mode:	Power Averaging over 100 traces

8.7.4 Test data

Table 8.7-1: Conducted PSD and EIRPSD measurements for *single carrier* operation within congested areas

(BW) Channel	Antenna port	Frequency, MHz	PSD, dBm/100 kHz	PSD limit, dBm/100 kHz	Margin, dB	Antenna gain, dBi	EIRP PSD, dBm/100 kHz	EIRPSD limit, dBm/100 kHz	Margin, dB
(6 MHz) Low	1	473	5.56	6.10	0.54	12.50	18.06	18.60	0.54
(6 MHz) Mid	1	587	5.95	6.10	0.15	12.50	18.45	18.60	0.15
(6 MHz) High	1	695	5.07	6.10	1.03	12.50	17.57	18.60	1.03
(6 MHz) Low	2	473	5.89	6.10	0.21	12.50	18.39	18.60	0.21
(6 MHz) Mid	2	587	5.90	6.10	0.20	12.50	18.40	18.60	0.20
(6 MHz) High	2	695	5.77	6.10	0.33	12.50	18.27	18.60	0.33
(12 MHz) Low	1	476	2.77	6.10	3.33	12.50	15.27	18.60	3.33
(12 MHz) Mid	1	584	4.44	6.10	1.66	12.50	16.94	18.60	1.66
(12 MHz) High	1	692	4.11	6.10	1.99	12.50	16.61	18.60	1.99
(12 MHz) Low	2	476	2.94	6.10	3.16	12.50	15.44	18.60	3.16
(12 MHz) Mid	2	584	5.09	6.10	1.01	12.50	17.59	18.60	1.01
(12 MHz) High	2	692	4.11	6.10	1.99	12.50	16.61	18.60	1.99
(24 MHz) Low	1	482	0.48	6.10	5.62	12.50	12.98	18.60	5.62
(24 MHz) Mid	1	584	2.74	6.10	3.36	12.50	15.24	18.60	3.36
(24 MHz) High	1	686	1.37	6.10	4.73	12.50	13.87	18.60	4.73
(24 MHz) Low	2	482	0.82	6.10	5.28	12.50	13.32	18.60	5.28
(24 MHz) Mid	2	584	3.72	6.10	2.38	12.50	16.22	18.60	2.38
(24 MHz) High	2	686	2.28	6.10	3.82	12.50	14.78	18.60	3.82

Table 8.7-2: Conducted PSD and EIRPSD measurements for *single carrier* operation within less congested areas

(BW) Channel	Antenna port	Frequency, MHz	PSD, dBm/100 kHz	PSD limit, dBm/100 kHz	Margin, dB	Antenna gain*, dBi	EIRP PSD, dBm/100 kHz	EIRPSD limit, dBm/100 kHz	Margin, dB
(6 MHz) Low	1	473	6.71	10.10	3.39	12.50	19.21	22.60	3.39
(6 MHz) Mid	1	587	5.74	10.10	4.36	12.50	18.24	22.60	4.36
(6 MHz) High	1	695	5.77	10.10	4.33	12.50	18.27	22.60	4.33
(6 MHz) Low	2	473	5.38	10.10	4.72	12.50	17.88	22.60	4.72
(6 MHz) Mid	2	587	6.08	10.10	4.02	12.50	18.58	22.60	4.02
(6 MHz) High	2	695	6.03	10.10	4.07	12.50	18.53	22.60	4.07
(12 MHz) Low	1	476	3.13	10.10	6.97	12.50	15.63	22.60	6.97
(12 MHz) Mid	1	584	4.47	10.10	5.63	12.50	16.97	22.60	5.63
(12 MHz) High	1	692	3.87	10.10	6.23	12.50	16.37	22.60	6.23
(12 MHz) Low	2	476	4.00	10.10	6.10	12.50	16.50	22.60	6.10
(12 MHz) Mid	2	584	5.40	10.10	4.70	12.50	17.90	22.60	4.70
(12 MHz) High	2	692	4.37	10.10	5.73	12.50	16.87	22.60	5.73
(24 MHz) Low	1	482	1.53	10.10	8.57	12.50	14.03	22.60	8.57
(24 MHz) Mid	1	584	2.92	10.10	7.18	12.50	15.42	22.60	7.18
(24 MHz) High	1	686	2.32	10.10	7.78	12.50	14.82	22.60	7.78
(24 MHz) Low	2	482	1.33	10.10	8.77	12.50	13.83	22.60	8.77
(24 MHz) Mid	2	584	4.25	10.10	5.85	12.50	16.75	22.60	5.85
(24 MHz) High	2	686	3.14	10.10	6.96	12.50	15.64	22.60	6.96



Table 8.7-3: Conducted PSD and EIRPSD measurements for *multi carrier* operation within congested areas

Channel BW	Antenna port	Frequency, MHz	PSD, dBm/100 kHz	PSD limit, dBm/100 kHz	Margin, dB	Antenna gain, dBi	EIRP PSD, dBm/100 kHz	EIRPSD limit, dBm/100 kHz	Margin, dB
6 MHz	1	473 + 479	3.40	6.10	2.70	12.50	15.90	18.60	2.70
6 MHz	1	689 + 695	4.12	6.10	1.98	12.50	16.62	18.60	1.98
6 MHz	2	473 + 479	4.27	6.10	1.83	12.50	16.77	18.60	1.83
6 MHz	2	689 + 695	3.22	6.10	2.88	12.50	15.72	18.60	2.88
12 MHz	1	476 + 488	1.23	6.10	4.87	12.50	13.73	18.60	4.87
12 MHz	1	680 + 692	2.00	6.10	4.10	12.50	14.50	18.60	4.10
12 MHz	2	476 + 488	1.89	6.10	4.21	12.50	14.39	18.60	4.21
12 MHz	2	680 + 692	1.35	6.10	4.75	12.50	13.85	18.60	4.75
24 MHz	1	482 + 506	-0.92	6.10	7.02	12.50	11.58	18.60	7.02
24 MHz	1	662 + 686	-0.53	6.10	6.63	12.50	11.97	18.60	6.63
24 MHz	2	482 + 506	-0.55	6.10	6.65	12.50	11.95	18.60	6.65
24 MHz	2	662 + 686	0.21	6.10	5.89	12.50	12.71	18.60	5.89

Table 8.7-4: Conducted PSD and EIRPSD measurements for *multi carrier* operation within less congested areas

Channel BW	Antenna port	Frequency, MHz	PSD, dBm/100 kHz	PSD limit, dBm/100 kHz	Margin, dB	Antenna gain, dBi	EIRP PSD, dBm/100 kHz	EIRPSD limit, dBm/100 kHz	Margin, dB
6 MHz	1	473 + 479	4.57	10.10	5.53	12.50	17.07	22.60	5.53
6 MHz	1	689 + 695	4.28	10.10	5.82	12.50	16.78	22.60	5.82
6 MHz	2	473 + 479	5.42	10.10	4.68	12.50	17.92	22.60	4.68
6 MHz	2	689 + 695	4.21	10.10	5.89	12.50	16.71	22.60	5.89
12 MHz	1	476 + 488	1.67	10.10	8.43	12.50	14.17	22.60	8.43
12 MHz	1	680 + 692	2.13	10.10	7.97	12.50	14.63	22.60	7.97
12 MHz	2	476 + 488	2.43	10.10	7.67	12.50	14.93	22.60	7.67
12 MHz	2	680 + 692	2.36	10.10	7.74	12.50	14.86	22.60	7.74
24 MHz	1	482 + 506	-0.38	10.10	10.48	12.50	12.12	22.60	10.48
24 MHz	1	662 + 686	0.44	10.10	9.66	12.50	12.94	22.60	9.66
24 MHz	2	482 + 506	-0.09	10.10	10.19	12.50	12.41	22.60	10.19
24 MHz	2	662 + 686	0.92	10.10	9.18	12.50	13.42	22.60	9.18



Section 8
Test name
Specification

Testing data
FCC 15.709(b)(ii) The power spectral density from the TVBD
FCC Part 15 Subpart H

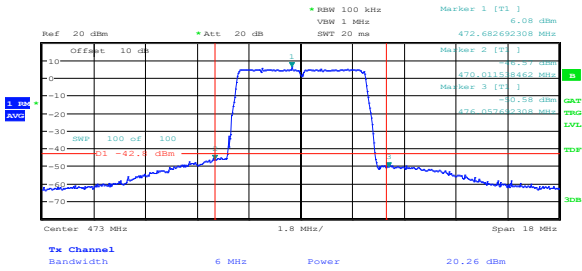

Figure 8.7-1: PSD within 100 kHz and Power within 6 MHz sample plot for single 6 MHz channel

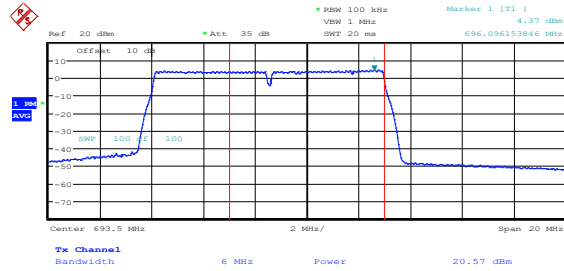

Figure 8.7-2: PSD within 100 kHz and Power within 6 MHz sample plot for single 12 MHz channel

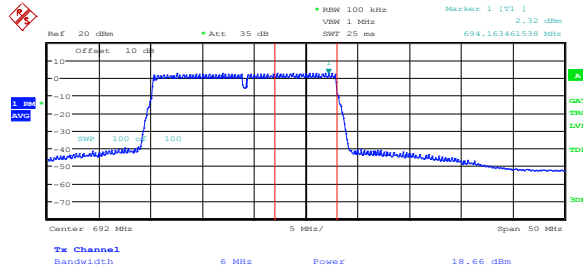

Figure 8.7-3: PSD within 100 kHz and Power within 6 MHz sample plot for single 24 MHz channel

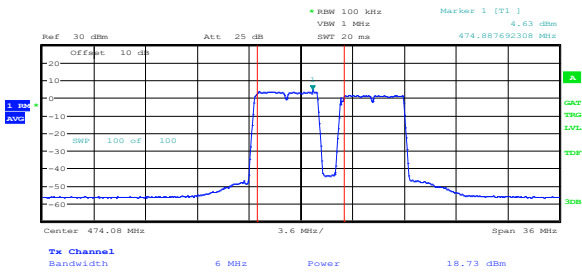

Figure 8.7-4: PSD within 100 kHz and Power within 6 MHz sample plot for multi 6 MHz channel

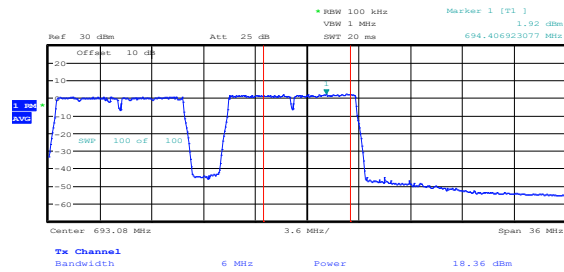

Figure 8.7-5: PSD within 100 kHz and Power within 6 MHz sample plot for multi 12 MHz channel

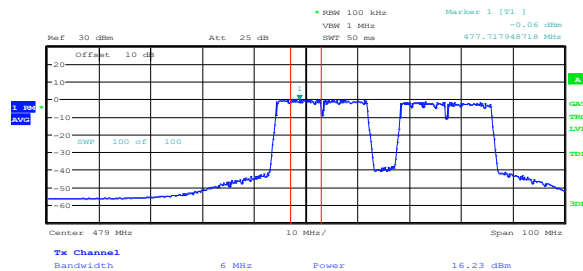

Figure 8.7-6: PSD within 100 kHz and Power within 6 MHz sample plot for multi 24 MHz channel

8.8 FCC 15.709(d) Transmitter band edge and adjacent channel power for fixed TVBDs

8.8.1 Definitions and limits

(1) The adjacent channel emission limits apply in the six-megahertz channel immediately adjacent to each white space channel or group of contiguous white space channels in which the white space device is operating.

Fixed devices with 36 dBm EIRP: -42.8 dBm/100 kHz conducted power.

(2) At frequencies beyond the six-megahertz channel immediately adjacent to each white space channel or group of contiguous white space channels in which the white space device is operating the white space device shall meet the requirements of §15.209.

(3) Emission measurements in the adjacent bands shall be performed using a minimum resolution bandwidth of 100 kHz with an average detector. A narrower resolution bandwidth may be employed near the band edge, when necessary, provided the measured energy is integrated to show the total power over 100 kHz.

(b)(1)(ii) For operation at EIRP levels of 36 dBm (4,000 mW) or less, fixed white space devices may operate at EIRP levels between the values shown in the table in paragraph (b)(1)(iii) of this section provided that the conducted power and the conducted power spectral density (PSD) limits are linearly interpolated between the values shown and the adjacent channel emission limit of the higher value shown in the table is met. Operation at EIRP levels above 36 dBm (4,000 mW) shall follow the requirements for 40 dBm (10,000 mW).

8.8.2 Test date

Start date October 22, 2019

8.8.3 Observations, settings and special notes

Adjacent channel is located 100 kHz away from the Band edge frequency and they both have the same limit, therefore 'Based edge level' reported in the tables below is the highest measured value between the two.

Table 8.8-1: Table 1 to 15.709 Paragraph (b)(1)(iii)

EIRP (6 MHz)	Conducted power limit (6 MHz)	Conducted PSD limit (dBm/100 kHz)	Conducted adjacent channel emission limit (dBm/100 kHz)
16 dBm (40 mW)	10 dBm (10 mW)	-7.4	-62.8
20 dBm (100 mW)	14 dBm (25 mW)	-3.4	-58.8
24 dBm (250 mW)	18 dBm (63 mW)	0.6	-54.8
28 dBm (625 mW)	22 dBm (158 mW)	4.6	-50.8
32 dBm (1600 mW)	26 dBm (400 mW)	8.6	-46.8
36 dBm (4000 mW)	30 dBm (1000 mW)	12.6	-42.8
40 dBm (10000 mW)	30 dBm (1000 mW)	12.6	-42.8

Calculation of the limits.

For operation within congested areas, at the max EIRP of 36 dBm, with total antenna gain of 12.5 dBi, the limit needs to be reduced by (12.5 dBi - 6 dBi) = 6.5 dB from -42.8 dBm/100 kHz to -49.3 dBm/100 kHz, but according to 15.709(b)(1)(ii), the value -49.3 dBm/100 kHz is located between -46.8 dBm/100 kHz to -50.8 dBm/100 kHz (in the Table above), therefore the higher value of -46.8 dBm/100 kHz for Adjacent Channel and Band Edge limit was chosen.

For operation within less congested areas, at the max EIRP of 40 dBm, with total antenna gain of 12.5 dBi, the limit needs to be reduced by (12.5 dBi - 10 dBi) = 2.5 dB from -42.8 dBm/100 kHz to -45.3 dBm/100 kHz, but according to 15.709(b)(1)(ii), the value -45.3 dBm/100 kHz is located between -42.8 dBm/100 kHz to -46.8 dBm/100 kHz (in the Table above), therefore the higher value of -42.8 dBm/100 kHz for Adjacent Channel and Band Edge limit was chosen.

Spectrum analyser settings for adjacent channel power and band edge power:

Resolution bandwidth:	100 kHz
Video bandwidth:	300 kHz
Detector mode:	RMS
Trace mode:	Power Averaging over 100 traces

8.8.4 Test data

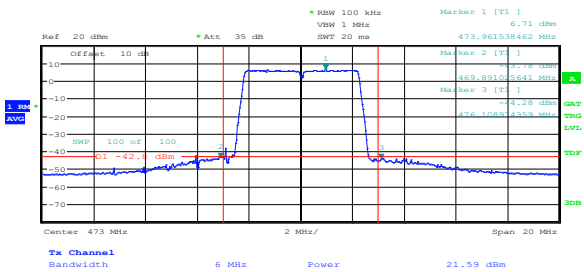

Figure 8.8-1: Conducted band edge and adjacent channel emissions sample plot for single 6 MHz channel

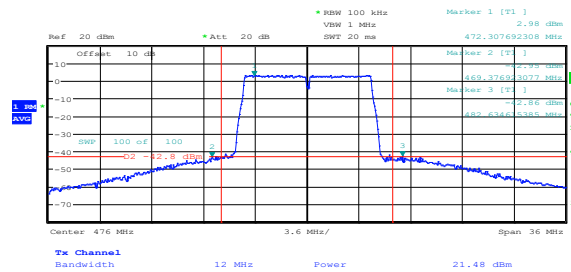

Figure 8.8-2: Conducted band edge and adjacent channel emissions sample plot for single 12 MHz channel

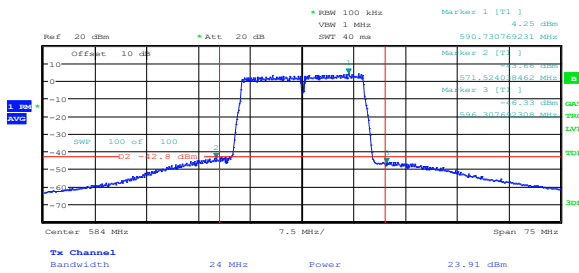

Figure 8.8-3: Conducted band edge and adjacent channel emissions sample plot for single 24 MHz channel

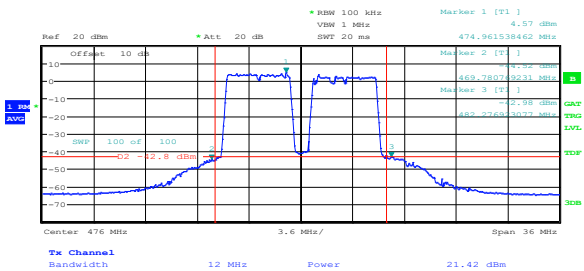

Figure 8.8-4: Conducted band edge and adjacent channel emissions sample plot for multi 6 MHz channel

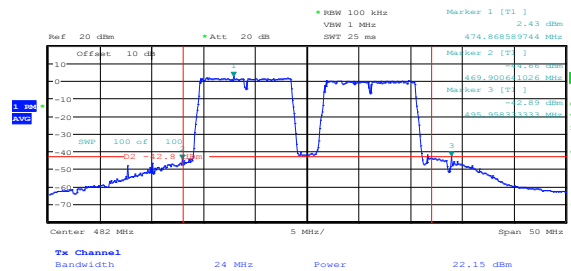

Figure 8.8-5: Conducted band edge and adjacent channel emissions sample plot for multi 12 MHz channel

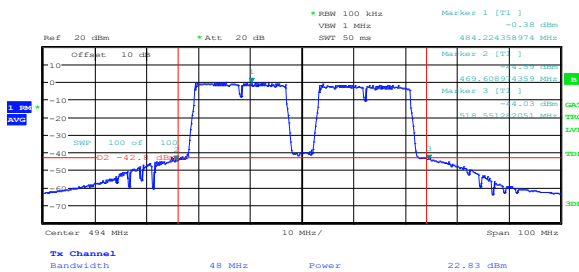

Figure 8.8-6: Conducted band edge and adjacent channel emissions sample plot for multi 24 MHz channel



Table 8.8-2: Band edge measurements for *single channel* operation within congested areas with 6 MHz channel

Channel	Antenna port	Frequency, MHz	Band edge level, dBm/100 kHz	Band edge limit, dBm/100 kHz	Margin, dB
Low	1	470.0	-46.96	-46.80	0.16
Low	1	476.0	-50.33	-46.80	3.53
Low	2	470.0	-48.84	-46.80	2.04
Low	2	476.0	-53.04	-46.80	6.24
Mid	1	584.0	-47.16	-46.80	0.36
Mid	1	590.0	-48.77	-46.80	1.97
Mid	2	584.0	-48.84	-46.80	2.04
Mid	2	590.0	-53.04	-46.80	6.24
High	1	692.0	-46.97	-46.80	0.17
High	1	698.0	-50.42	-46.80	3.62
High	2	692.0	-46.85	-46.80	0.05
High	2	698.0	-53.38	-46.80	6.58

Table 8.8-3: Band edge measurements for *single channel* operation within congested areas with 12 MHz channel

Channel	Antenna port	Frequency, MHz	Band edge level, dBm/100 kHz	Band edge limit, dBm/100 kHz	Margin, dB
Low	1	469.9	-46.88	-46.80	0.08
Low	1	482.0	-47.76	-46.80	0.96
Low	2	469.9	-49.08	-46.80	2.28
Low	2	482.1	-47.55	-46.80	0.75
Mid	1	577.9	-47.62	-46.80	0.82
Mid	1	590.1	-46.93	-46.80	0.13
Mid	2	578.0	-48.13	-46.80	1.33
Mid	2	590.1	-49.01	-46.80	2.21
High	1	685.9	-47.41	-46.80	0.61
High	1	698.0	-50.93	-46.80	4.13
High	2	680.0	-47.27	-46.80	0.47
High	2	698.0	-51.98	-46.80	5.18

Table 8.8-4: Band edge measurements for *single channel* operation within congested areas with 24 MHz channel

Channel	Antenna port	Frequency, MHz	Band edge level, dBm/100 kHz	Band edge limit, dBm/100 kHz	Margin, dB
Low	1	469.9	-48.23	-46.80	1.43
Low	1	494.1	-47.29	-46.80	0.49
Low	2	469.9	-49.72	-46.80	2.92
Low	2	494.1	-48.02	-46.80	1.22
Mid	1	571.9	-47.55	-46.80	0.75
Mid	1	596.1	-46.99	-46.80	0.19
Mid	2	571.9	-47.37	-46.80	0.57
Mid	2	596.1	-50.07	-46.80	3.27
High	1	673.9	-47.37	-46.80	0.57
High	1	698.1	-48.17	-46.80	1.37
High	2	673.9	-47.62	-46.80	0.82
High	2	698.0	-51.95	-46.80	5.15



Table 8.8-5: Band edge measurements for *single channel* operation within *less congested* areas with 6 MHz channel

Channel	Antenna port	Frequency, MHz	Band edge level, dBm/100 kHz	Band edge limit, dBm/100 kHz	Margin, dB
Low	1	470.0	-43.78	-42.80	0.98
Low	1	476.0	-44.28	-42.80	1.48
Low	2	470.0	-43.56	-42.80	0.76
Low	2	476.0	-47.90	-42.80	5.10
Mid	1	584.0	-43.33	-42.80	0.53
Mid	1	590.0	-44.71	-42.80	1.91
Mid	2	584.0	-43.12	-42.80	0.32
Mid	2	590.0	-44.86	-42.80	2.06
High	1	692.0	-44.81	-42.80	2.01
High	1	698.0	-47.80	-42.80	5.00
High	2	692.0	-45.48	-42.80	2.68
High	2	698.0	-51.46	-42.80	8.66

Table 8.8-6: Band edge measurements for *single channel* operation within *less congested* areas with 12 MHz channel

Channel	Antenna port	Frequency, MHz	Band edge level, dBm/100 kHz	Band edge limit, dBm/100 kHz	Margin, dB
Low	1	469.9	-42.95	-42.80	0.15
Low	1	482.0	-42.86	-42.80	0.06
Low	2	469.9	-43.47	-42.80	0.67
Low	2	482.1	-45.28	-42.80	2.48
Mid	1	577.9	-42.91	-42.80	0.11
Mid	1	590.1	-46.23	-42.80	3.43
Mid	2	578.0	-43.95	-42.80	1.15
Mid	2	590.1	-47.33	-42.80	4.53
High	1	685.9	-43.30	-42.80	0.50
High	1	698.0	-45.85	-42.80	3.05
High	2	680.0	-43.70	-42.80	0.90
High	2	698.0	-46.86	-42.80	4.06

Table 8.8-7: Band edge measurements for *single channel* operation within *less congested* areas with 24 MHz channel

Channel	Antenna port	Frequency, MHz	Band edge level, dBm/100 kHz	Band edge limit, dBm/100 kHz	Margin, dB
Low	1	469.9	-43.47	-42.80	0.67
Low	1	494.1	-44.16	-42.80	1.36
Low	2	469.9	-42.82	-42.80	0.02
Low	2	494.1	-43.60	-42.80	0.80
Mid	1	571.9	-44.59	-42.80	1.79
Mid	1	596.1	-43.48	-42.80	0.68
Mid	2	571.9	-43.66	-42.80	0.86
Mid	2	596.1	-46.33	-42.80	3.53
High	1	673.9	-42.81	-42.80	0.01
High	1	698.1	-43.16	-42.80	0.36
High	2	673.9	-43.70	-42.80	0.90
High	2	698.0	-46.00	-42.80	3.20



Table 8.8-8: Band edge measurements for *multi channel* operation within congested areas with 6 MHz channel

Channel	Antenna port	Frequency, MHz	Band edge level, dBm/100 kHz	Band edge limit, dBm/100 kHz	Margin, dB
Low × 2	1	470.0	-49.06	-46.80	2.26
Low × 2	1	482.0	-46.83	-46.80	0.03
Low × 2	2	470.0	-49.04	-46.80	2.24
Low × 2	2	482.0	-47.36	-46.80	0.56
High × 2	1	692.0	-47.67	-46.80	0.87
High × 2	1	704.0	-47.22	-46.80	0.42
High × 2	2	692.0	-48.24	-46.80	1.44
High × 2	2	704.0	-47.86	-46.80	1.06

Table 8.8-9: Band edge measurements for *multi channel* operation within less congested areas with 6 MHz channel

Channel	Antenna port	Frequency, MHz	Band edge level, dBm/100 kHz	Band edge limit, dBm/100 kHz	Margin, dB
Low × 2	1	470.0	-44.52	-42.80	1.72
Low × 2	1	482.0	-42.98	-42.80	0.18
Low × 2	2	470.0	-43.50	-42.80	0.70
Low × 2	2	482.0	-42.82	-42.80	0.02
High × 2	1	692.0	-43.56	-42.80	0.76
High × 2	1	704.0	-44.98	-42.80	2.18
High × 2	2	692.0	-43.29	-42.80	0.49
High × 2	2	704.0	-43.53	-42.80	0.73

Table 8.8-10: Band edge measurements for *multi channel* operation within congested areas with 12 MHz channel

Channel	Antenna port	Frequency, MHz	Band edge level, dBm/100 kHz	Band edge limit, dBm/100 kHz	Margin, dB
Low × 2	1	470.0	-48.23	-46.80	1.43
Low × 2	1	496.0	-48.81	-46.80	2.01
Low × 2	2	470.0	-48.32	-46.80	1.52
Low × 2	2	496.0	-47.53	-46.80	0.73
High × 2	1	674.0	-48.86	-46.80	2.06
High × 2	1	698.0	-46.93	-46.80	0.13
High × 2	2	674.0	-48.28	-46.80	1.48
High × 2	2	698.0	-48.28	-46.80	1.48

Table 8.8-11: Band edge measurements for *multi channel* operation within less congested areas with 12 MHz channel

Channel	Antenna port	Frequency, MHz	Band edge level, dBm/100 kHz	Band edge limit, dBm/100 kHz	Margin, dB
Low × 2	1	470.0	-44.88	-42.80	2.08
Low × 2	1	496.0	-45.19	-42.80	2.39
Low × 2	2	470.0	-44.66	-42.80	1.86
Low × 2	2	496.0	-42.89	-42.80	0.09
High × 2	1	674.0	-42.90	-42.80	0.10
High × 2	1	698.0	-45.56	-42.80	2.76
High × 2	2	674.0	-42.82	-42.80	0.02
High × 2	2	698.0	-42.89	-42.80	0.09



Table 8.8-12: Band edge measurements for **multi channel** operation within congested areas with 24 MHz channel

Channel	Antenna port	Frequency, MHz	Band edge level, dBm/100 kHz	Band edge limit, dBm/100 kHz	Margin, dB
Low × 2	1	470.0	-46.83	-46.80	0.03
Low × 2	1	518.0	-49.10	-46.80	2.30
Low × 2	2	470.0	-48.02	-46.80	1.22
Low × 2	2	518.0	-47.80	-46.80	1.00
High × 2	1	650.0	-47.84	-46.80	1.04
High × 2	1	698.0	-48.75	-46.80	1.95
High × 2	2	650.0	-48.94	-46.80	2.14
High × 2	2	698.0	-46.83	-46.80	0.03

Table 8.8-13: Band edge measurements for **multi channel** operation within less congested areas with 24 MHz channel

Channel	Antenna port	Frequency, MHz	Band edge level, dBm/100 kHz	Band edge limit, dBm/100 kHz	Margin, dB
Low × 2	1	470.0	-44.59	-42.80	1.79
Low × 2	1	518.0	-44.03	-42.80	1.23
Low × 2	2	470.0	-43.24	-42.80	0.44
Low × 2	2	518.0	-43.02	-42.80	0.22
High × 2	1	650.0	-43.60	-42.80	0.80
High × 2	1	698.0	-42.83	-42.80	0.03
High × 2	2	650.0	-42.82	-42.80	0.02
High × 2	2	698.0	-43.50	-42.80	0.70

8.9 FCC 15.709(d)(2) Radiated spurious emissions beyond the television channels

8.9.1 Definitions and limits

At frequencies beyond the television channels immediately adjacent to the channel in which the TVBD is operating, the radiated emissions from TVBDs shall meet the requirements of § 15.209.

Table 8.9-1: FCC §15.209 Radiated emission limits

Frequency, MHz	Field strength of emissions		Measurement distance
	$\mu\text{V/m}$	$\text{dB}\mu\text{V/m}$	m
30–88	100	40.0	3
88–216	150	43.5	3
216–960	200	46.0	3
above 960	500	54.0	3

Notes: In the emission table above, the tighter limit applies at the band edges.

For frequencies above 1 GHz the limit on peak RF emissions is 20 dB above the maximum permitted average emission limit applicable to the equipment under test

8.9.2 Test date

Start date: October 22, 2019

8.9.3 Observations, settings and special notes

The spectrum was searched from 30 MHz to the 7 GHz.

Radiated measurements were performed at a distance of 3 m. Radiated emissions were performed while EUT was transmitting at the narrowest channel bandwidth with the highest PSD.

Spectrum analyser settings for radiated measurements below 1 GHz:

Resolution bandwidth:	120 kHz
Video bandwidth:	300 kHz
Detector mode:	Peak or Quasi-peak
Trace mode:	Max Hold

Spectrum analyser settings for peak radiated measurements above 1 GHz:

Resolution bandwidth:	1 MHz
Video bandwidth:	3 MHz
Detector mode:	Peak
Trace mode:	Max Hold

Spectrum analyser settings for average radiated measurements above 1 GHz:

Resolution bandwidth:	1 MHz
Video bandwidth:	3 MHz
Detector mode:	Average
Trace mode:	Max Hold

8.9.4 Test data

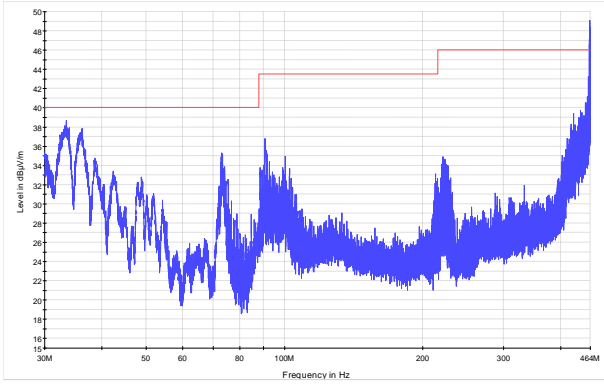

Figure 8.9-1: Radiated spurious emissions within 30–464 MHz for low channel

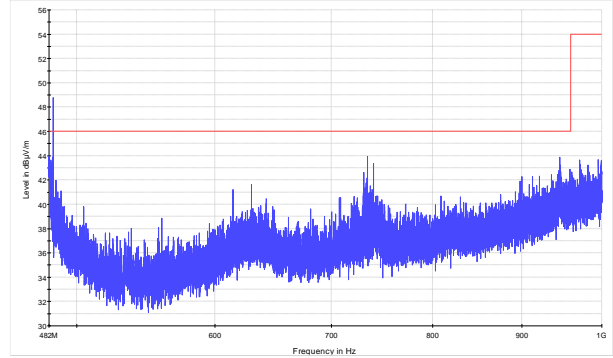

Figure 8.9-2: Radiated spurious emissions within 482–1000 MHz for low channel

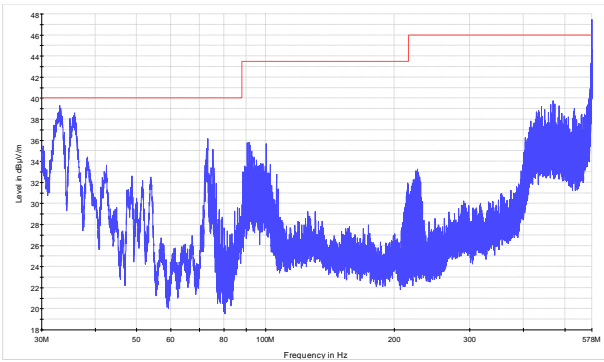

Figure 8.9-3: Radiated spurious emissions within 30–578 MHz for mid channel

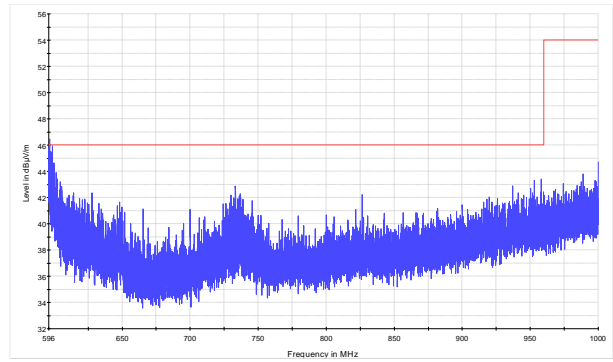

Figure 8.9-4: Radiated spurious emissions within 596–1000 MHz for mid channel

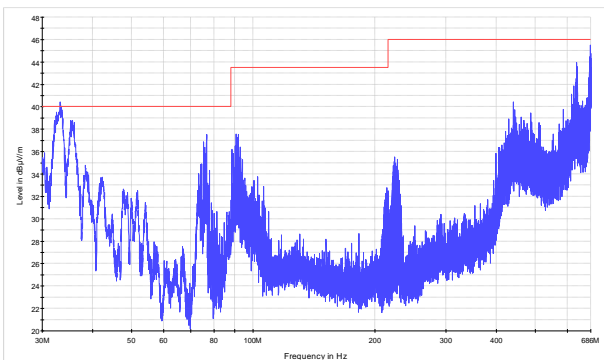

Figure 8.9-5: Radiated spurious emissions within 30–686 MHz for high channel

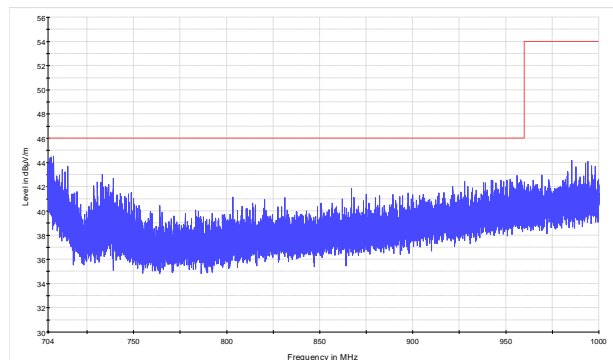

Figure 8.9-6: Radiated spurious emissions within 704–1000 MHz for high channel

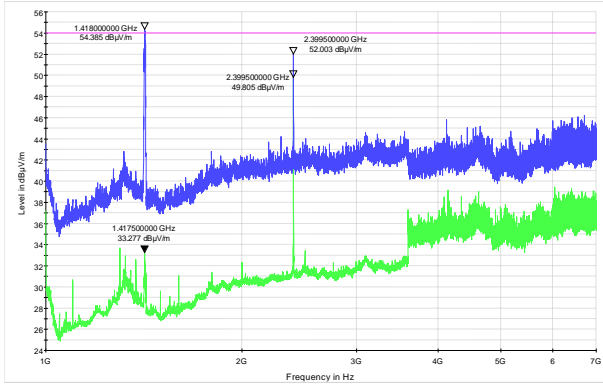

Figure 8.9-7: Radiated spurious emissions within 1–7 GHz for low channel

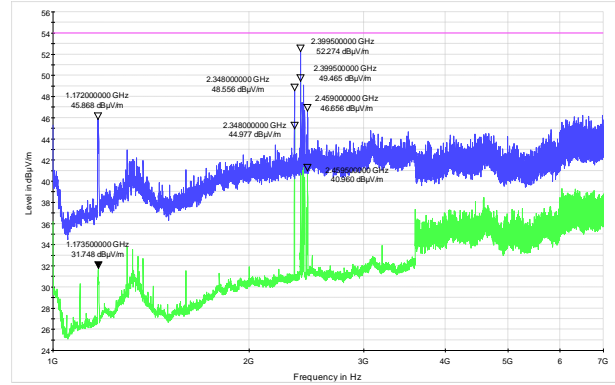

Figure 8.9-8: Radiated spurious emissions within 1–7 GHz for mid channel

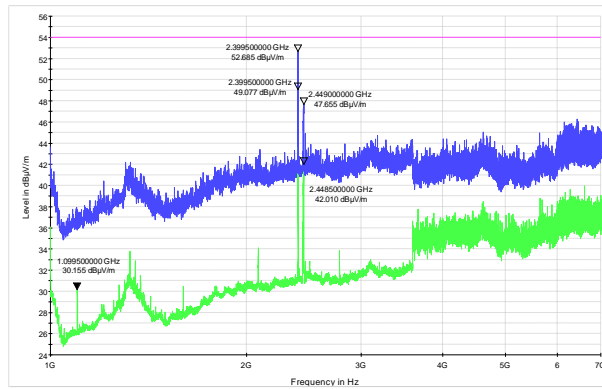

Figure 8.9-9: Radiated spurious emissions within 1–7 GHz for high channel

Table 8.9-2: TV bands band edge measurements results

Channel	Frequency, MHz	Quasi-peak level, dBµV/m	Quasi-peak limit, dBµV/m	Margin, dB
Low	464.0	43.99	46.00	2.01
Low	482.0	42.74	46.00	3.26
Mid	578.0	44.10	46.00	1.90
Mid	596.0	45.04	46.00	0.96
High	686.0	41.42	46.00	4.58
High	704.0	42.05	46.00	3.95

Section 9. Block diagrams and photos of test set-ups

9.1 Radiated emissions set-up for frequencies below 1 GHz

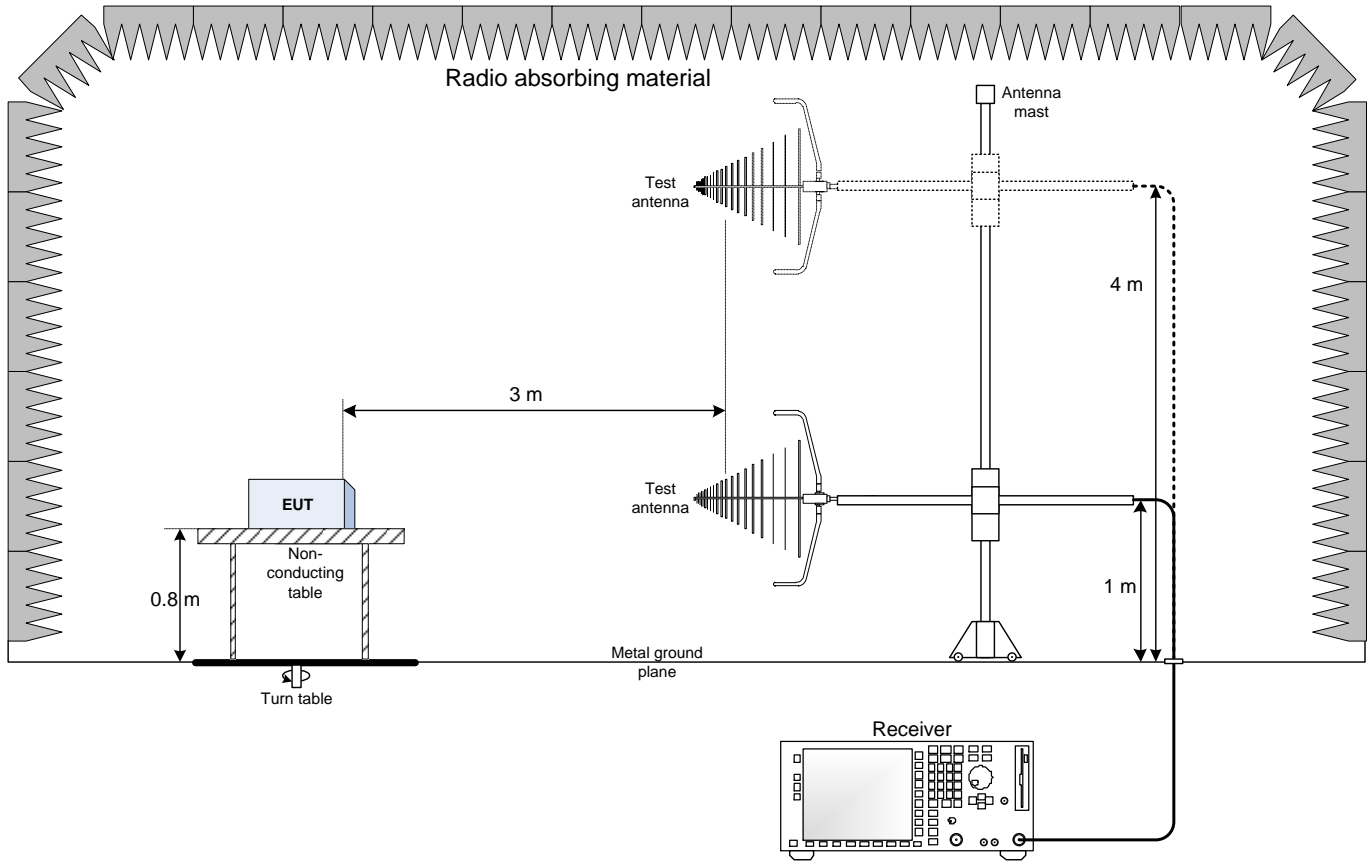

9.2 Radiated emissions set-up for frequencies above 1 GHz

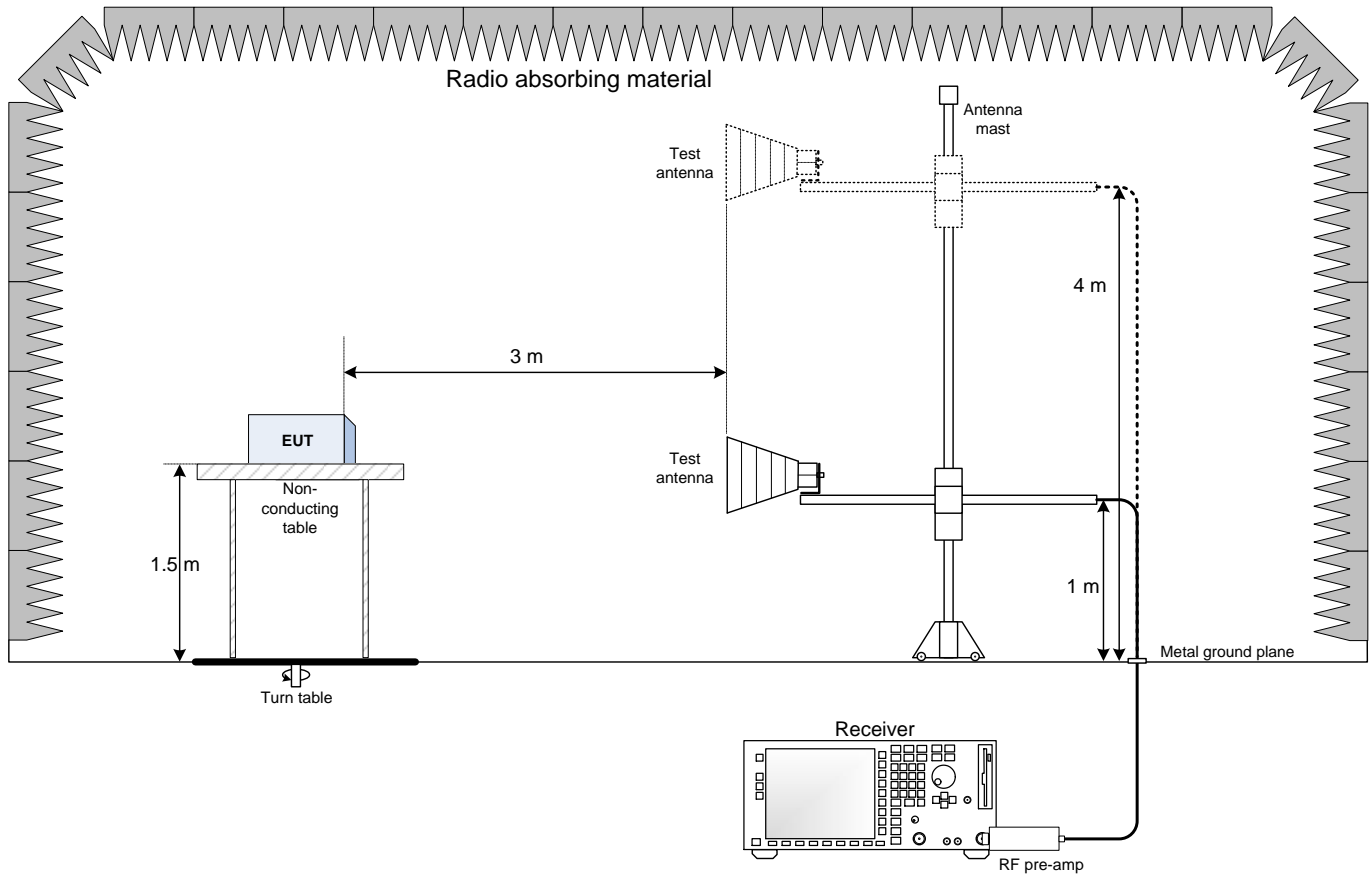

9.3 Conducted emissions set-up

