

OPTICON

Data Collector with GPS & Bluetooth

OPL 9813



The OPL 9813 is a laser data collector featuring GPS (Global Positioning System) feature, Bluetooth 2.1 communication and time stamp functionality.

**Preliminary
Specifications Manual**

All information subject to change without notice.

Document History

| | | | |
|----------------------|------------|------------------------------|--|
| Model Number: | OPL 9813 | Specification Number: | |
| Edition: | 2 | Original Spec Number: | |
| Date: | 2012-02-23 | | |

Copyright 2012 Opticon. All rights reserved.

This manual may not, in whole or in part, be copied, photocopied, reproduced, translated or converted to any electronic or machine readable form without prior written consent of Opticon.

Limited Warranty and Disclaimers

PLEASE READ THIS MANUAL CAREFULLY BEFORE INSTALLING OR USING THE PRODUCT.

Serial Number

A serial number appears on all Opticon products. This official registration number is directly related to the device purchased. Do not remove the serial number from your Opticon device. Removing the serial number voids the warranty.

Warranty

Unless otherwise agreed in a written contract, all Opticon products are warranted against defects in materials and workmanship for two years after purchase. Opticon will repair or, at its option, replace products that are defective in materials or workmanship with proper use during the warranty period. Opticon is not liable for damages caused by modifications made by a customer. In such cases, standard repair charges will apply. If a product is returned under warranty and no defect is found, standard repair charges will apply. Opticon assumes no liability for any direct, indirect, consequential or incidental damages arising out of use or inability to use both the hardware and software, even if Opticon has been informed about the possibility of such damages.

Packaging

The packing materials are recyclable. We recommend that you save all packing material to use should you need to transport your data collector or send it for service. Damage caused by improper packaging during shipment is not covered by the warranty.

Trademarks

Trademarks used are the property of their respective owners.

Opticon Inc. and Opticon Sensors Europe B.V. are wholly owned subsidiaries of OPTOELECTRONICS Co., Ltd., 12-17, Tsukagoshi 4-chome, Warabi-shi, Saitama, Japan 335-0002. TEL +81-(0) 48-446-1183; FAX +81-(0) 48-446-1184

SUPPORT

USA

Phone: 800-636-0090

Email: support@opticonusa.com

Web: www.opticonusa.com

Europe

Email: support@opticon.com

Web: www.opticon.com

Contents

| | |
|---|-----------|
| 1. Abstract | 5 |
| 2. Overview | 5 |
| 3. Physical Features | 6 |
| 3.1. Dimensions | 6 |
| 3.2. Weight..... | 6 |
| 3.3. Color | 6 |
| 4. Environmental Specifications | 6 |
| 4.1. Operating Temperature and Humidity..... | 6 |
| 4.2. Storage Temperature and Humidity..... | 6 |
| 4.3. IP (dust/water) rating | 6 |
| 4.4. Drop | 6 |
| 4.5. Ambient Light Immunity | 7 |
| 5. Controls | 8 |
| 6. Electrical Specifications | 8 |
| 6.1. Main Battery | 8 |
| 6.2. Battery Operating Time and Charging Time | 8 |
| 7. Optical Specifications | 9 |
| 7.1. Laser Scan Specifications | 9 |
| 8. Technical Specifications | 9 |
| 8.1. Print Contrast Signal (PCS)..... | 9 |
| 8.2. Minimum Resolution | 9 |
| 8.3. Scan Area and Resolution | 10 |
| 8.3.1. Depth of Field..... | 10 |
| 8.4. Pitch, Skew, and Tilt..... | 11 |
| 8.4.1. Pitch Angle..... | 11 |
| 8.4.2. Skew Angle and Dead Zone | 12 |
| 8.4.3. Tilt Angle | 13 |
| 8.5. Curvature | 14 |
| 9. Interface Specifications | 14 |
| 9.1. Bluetooth..... | 14 |
| 9.2. Infrared Transmission (IrDA) | 14 |
| 9.3. GPS | 15 |
| 10. Serial Number | 16 |
| 10.1. Dimensions and location..... | 16 |
| 10.2. Detailed drawing..... | 17 |

| | |
|---|-----------|
| 10.3. Serial number | 17 |
| 10.4. Manufacturing date..... | 18 |
| 11. Packaging Specifications..... | 19 |
| 11.1. Individual Packaging Specification..... | 19 |
| 11.2. Accessory Specification..... | 20 |
| 11.3. Collective Packaging Specification | 20 |
| 12. Durability | 21 |
| 12.1. Drop Test (without packaging)..... | 21 |
| 12.2. Dust and Drip Proof | 21 |
| 13. Reliability | 21 |
| 14. Regulatory Compliance..... | 21 |
| 14.1. Laser Safety | 21 |
| 14.2. Certifications..... | 22 |
| 14.3. RoHS | 22 |
| 14.4. State of California: Perchlorate Best Management Practices..... | 22 |
| 15. Safety..... | 23 |
| 15.1. Shock | 23 |
| 15.2. Temperature Conditions | 23 |
| 15.3. Foreign Materials..... | 23 |
| 15.4. Other | 23 |
| 16. Mechanical Drawing | 24 |

Table of Figures

| | |
|--|----|
| Figure 1: Ambient Light Immunity..... | 7 |
| Figure 2: Depth of field | 10 |
| Figure 3: Pitch | 11 |
| Figure 4: Skew and dead zone | 12 |
| Figure 5: Tilt angle | 13 |
| Figure 6: Curvature..... | 14 |
| Figure 7: Name plate and serial number | 16 |
| Figure 8: Name plate and serial number details | 17 |
| Figure 9: Individual packaging | 19 |
| Figure 10: Collective packaging | 20 |
| Figure 11: Drop test | 21 |
| Figure 12: Mechanical drawing | 24 |

1. Abstract

This manual provides specifications for the OPL 9813 barcode data collector.

2. Overview

The OPL 9813 is a barcode data collector that contains a compact laser module.

This data collector offers efficient scanning performance that is suitable for various business environments and is able to store scanned data and data configured via keyboard input.

Infra-red radiation communication is one of communication functions of the OPL 9813.

Stored data can be sent to the host computer by IrDA Ver.1.2-compliant infra-red radiation communication (using a dedicated cradle).

The OPL 9813 is a laser data collector with a GPS (Global Positioning System) feature and clock function. Those extra features of the OPL 9813 make it possible to add location data and a time stamp to scanned barcode data.

Supported symbologies:

Linear (1D)

JAN/UPC/EAN, incl. add-on
Codabar/NW-7
Code 11
Code 39
Code 93
Code 128
GS1-128 (EAN-128)
GS1 Databar (RSS)
IATA
Industrial 2of5
Interleaved 2of5
ISBN-ISSN
Matrix 2of5
MSI/Plessey
S-Code
Telepen
Tri-Optic
UK/Plessey

Postal

Chinese Post
Korean Postal Authority Code

2D

Composite Codes
MicroPDF417*
PDF417*

* Requires use of an external library.

The OPL 9813 can use a variety of cradles:

- CRD 9723 single bay cradle (1 x charging, 1 x communication)
- CRD 9723 multi bay cradle (5 x charging, 1 x communication)
- CRD 9723 multi bay cradle (5 x charging, 5 x communication)
- CRD 9722 single bay cradle (1 x charging, no communication)
- CRD 9726 single bay cradle with build-in telephone modem.
- CRD 9727 single bay cradle with build-in GSM modem.

C-language-based development tools are available for application development.

3. Physical Features

3.1. Dimensions

W 44.0 mm x D 22.0 mm x H 140.0 mm

3.2. Weight

115 g (max.), excluding the lithium-ion battery

3.3. Color

Black

4. Environmental Specifications

4.1. Operating Temperature and Humidity

Temperature: 0 to 40° C

Humidity: 20 to 85%

4.2. Storage Temperature and Humidity

Temperature: -20 to 60° C

Humidity: 20 to 90%

4.3. IP (dust/water) rating

IP 54

4.4. Drop

1.5m on concrete

4.5. Ambient Light Immunity

Decoding performance is guaranteed when the range of illumination on a barcode surface is between zero and the following values:

| | |
|--------------------|-----------|
| Incandescent light | 3,000 lx |
| Fluorescent light | 3,000 lx |
| Sunlight | 50,000 lx |

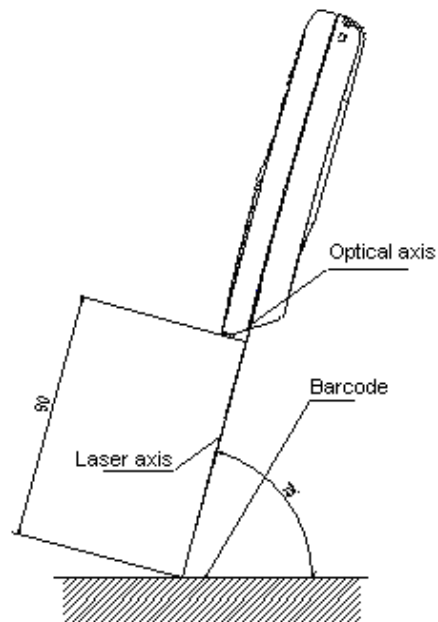

Figure 1: Ambient Light Immunity

Conditions

Barcode Sample: OPTOELECTRONICS Test Sample

| | |
|-------------|-----------------|
| PCS: | 0.9 |
| Resolution: | 0.25 mm |
| Symbology: | 8-digit Code 39 |
| Quiet Zone: | 10 mm |
| N/W Ratio: | 1:2.5 |

Direct light or specular reflection light from a source should be prevented from entering the acceptance area.

Note: α , β and γ respectively represent pitch, skew and tilt. Please see section 8 for how these values are defined.

5. Controls

| Item | Specifications | | Remarks |
|-----------------|-------------------------|--|---------|
| Controls | MPU | 32-bit microprocessor | |
| | Built-in ROM | 512 KB | |
| | Built-in RAM | 64 KB | |
| External memory | Flash ROM | 512 KB (Option: Max. 4 MB) | |
| | SRAM | 512 KB (Option: Max. 2 MB) | |
| Display | LCD | None | |
| | Dots | | |
| | Backlight | | |
| | Scanning indicators | Tricolor LED and buzzer | |
| Scanning | Laser wavelength/output | 650 nm / 1mW or less | |
| | Scanning frequency | 100 times/s | |
| Clock | Real time clock | Supports year, month, date, hour, minute and seconds (leap year supported) | |
| Keyboard | Up Trigger Down | Since the OPL9813 is fully programmable, the actual function of these keys is determined by the installed application. | |
| Buzzer | Loudness | 75 dB(A) or higher | |

6. Electrical Specifications

6.1. Main Battery

The main battery is a lithium-ion secondary battery.

Nominal capacity: 1000 mAh

Battery charging time: Approximately 3 hours

6.2. Battery Operating Time and Charging Time

| Parameter | Specifications | Notes |
|---------------------|----------------------------------|-------------------------------|
| Backup battery | 3 mAh manganese dioxide battery | |
| Current consumption | 1 mA or less (on standby) | |
| | 150 mA or less (when operating) | GPS & Bluetooth on. |
| Usable time | 50 hours or more (not using GPS) | 1 scan/5s |
| | 10 hours or more (using GPS) | |
| Data hold time | 72 hours or more | After main battery discharged |

Note: Battery life may be shorter than specified above when the quality of the battery pack is degraded.

7. Optical Specifications

7.1. Laser Scan Specifications

| Parameter | Specification | Unit |
|------------------------|---------------------------------|---------|
| Light-emitting element | Red laser diode | — |
| Emission wavelength | 650 ±10 (25° C) | nm |
| Light output | 1.0 or less | mW |
| Scanning method | Bi-directional vibration mirror | — |
| Scanning speed | 100 ±20 | scans/s |
| Scan angle | Scan angle: 54 ±5 | ° |
| | Read angle: 44 (Min) | ° |
| Resolution | 0.127 and above | mm |

Note: Refer to chapter 8, “Technical Specifications,” to read about scanning performance.

8. Technical Specifications

The conditions for technical specifications are as follows, unless otherwise specified in each section.

Conditions

| | |
|-----------------------------------|---|
| Ambient temperature and humidity: | Room temperature (5 to 35° C) Room humidity (45% to 85% RH) |
| Ambient light: | 500 to 900 lx |
| Background: | Barcode = black Space = white Margin = white Background of label = black |

8.1. Print Contrast Signal (PCS)

PCS=0.45 or higher (over 70% of reflectivity of space and quiet zone).

Scanning performance may decline if dirt or scratches mar the optical window. Keep the optical window clean.

8.2. Minimum Resolution

0.127 mm

8.3. Scan Area and Resolution

8.3.1. Depth of Field

The depth of field is measured from the edge of the data collector. The scanning range is within the circular arc centered on the scan origin.

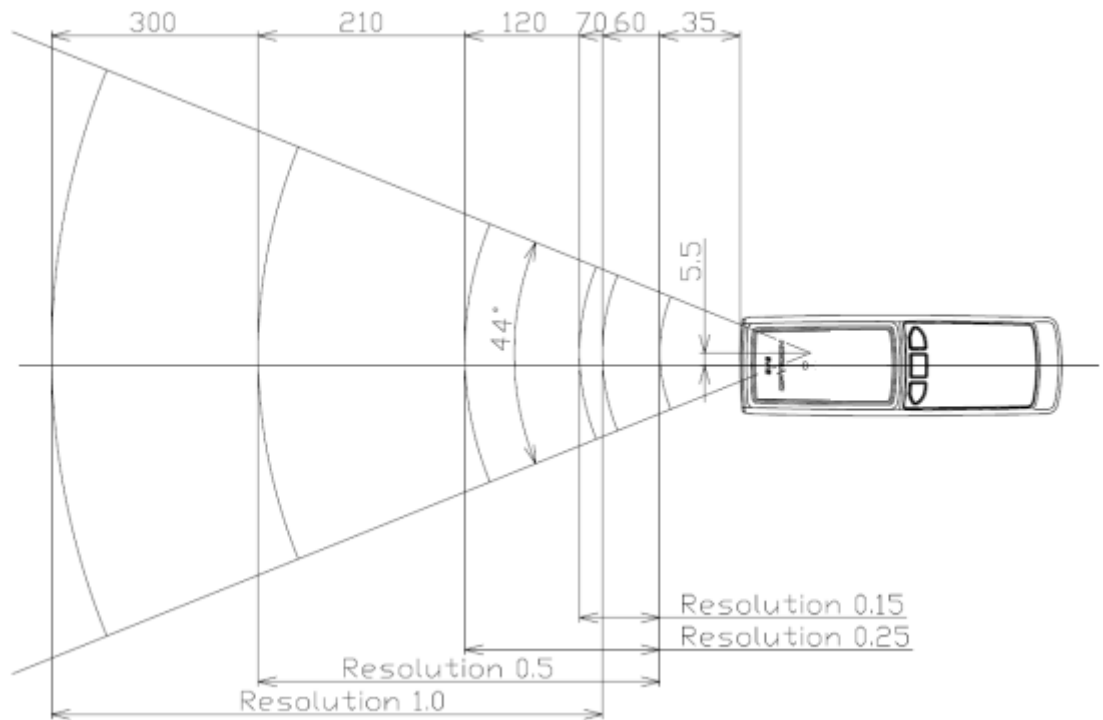

Figure 2: Depth of field

| Symbology | Resolution (mm) | Decode Depth (mm) | PCS |
|-----------|-----------------|-------------------|-----|
| Code 39 | 1.0 | 60–300 | 0.9 |
| Code 39 | 0.5 | 35–210 | 0.9 |
| Code 39 | 0.25 | 35–120 | 0.9 |
| Code 39 | 0.15 | 35–70 | 0.9 |

Conditions

Barcode Sample: OPTOELECTRONICS Test Sample

- N/W ratio: 1:2.5
- Angle: $\alpha = 0^\circ, \beta = 15^\circ, \gamma = 0^\circ$
- Curvature: $R = \infty$

| Resolution | Symbology | PCS | Quiet Zone | Digit |
|------------|-----------|-----|------------|-------|
| 1.0 mm | Code 39 | 0.9 | 25 mm | 1 |
| 0.5 mm | Code 39 | 0.9 | 18 mm | 3 |
| 0.25 mm | Code 39 | 0.9 | 10 mm | 8 |
| 0.15 mm | Code 39 | 0.9 | 7 mm | 10 |

Note: dirt or scratches on the mask will degrade scanning performance. Always handle the data collector carefully.

8.4. Pitch, Skew, and Tilt

8.4.1. Pitch Angle

$$\alpha = \pm 25^\circ$$

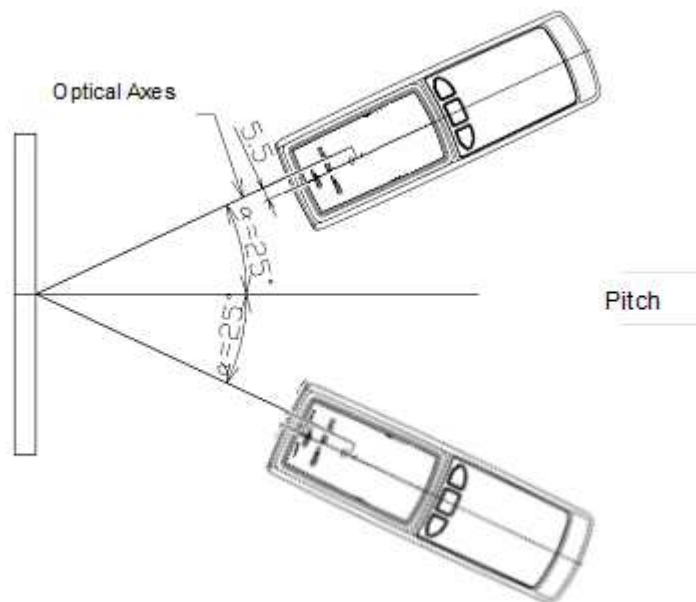

Figure 3: Pitch

Conditions

Barcode Sample: OPTOELECTRONICS Test Sample

Distance: 90 mm from the edge of the data collector

Label: **Pitch, Skew Angle**

PCS = 0.9, Resolution = 0.25 mm, Symbology = 9-digit Code 39,
Quiet Zone = 10 mm, N/W Ratio = 1:2.5

Dead Zone, Tilt Angle

PCS = 0.9, Resolution = 0.26 mm, Symbology = 13-digit JAN, Quiet Zone = 10 mm

Angle: Curvature: $R = \infty$, Skew Angle = $\beta + 15^\circ$ (for measuring Pitch Angle and Tilt Angle)

8.4.2. Skew Angle and Dead Zone

Skew angle: $\beta = \pm 50^\circ$ (Excluding dead zone)

Dead zone: $\beta = \pm 8^\circ$ (There are some areas in which decoding fails due to specular reflection)

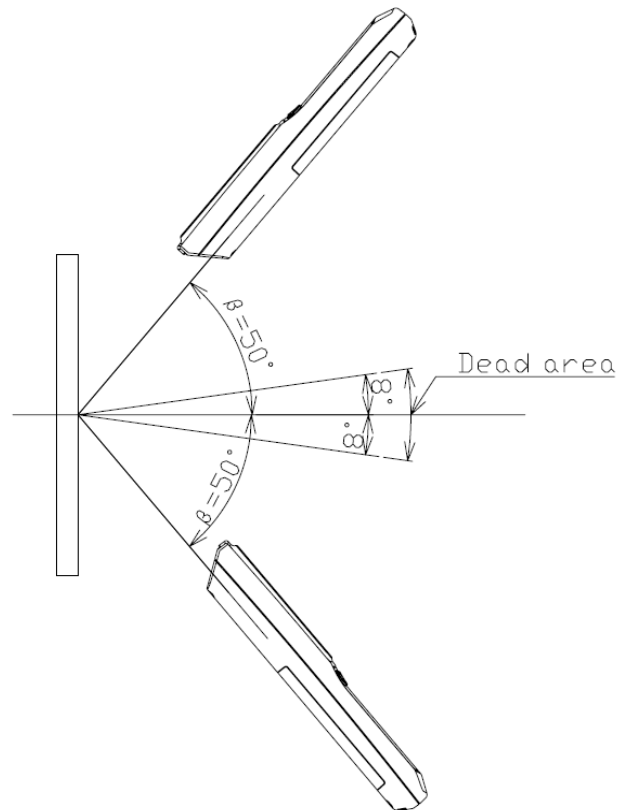

Figure 4: Skew and dead zone

Conditions

Barcode Sample: OPTOELECTRONICS Test Sample

Distance: 90 mm from the edge of the data collector

Label: **Pitch, Skew Angle**

PCS = 0.9, Resolution = 0.25 mm, Symbology = 9-digit Code 39,
Quiet Zone = 10 mm, N/W Ratio = 1:2.5

Dead Zone, Tilt Angle

PCS = 0.9, Resolution = 0.26 mm, Symbology = 13-digit JAN, Quiet Zone = 10 mm

Angle: Curvature: $R = \infty$, Skew Angle = $\beta + 15^\circ$ (for measuring Pitch Angle and Tilt Angle)

8.4.3. Tilt Angle

$$\gamma = \pm 20^\circ$$

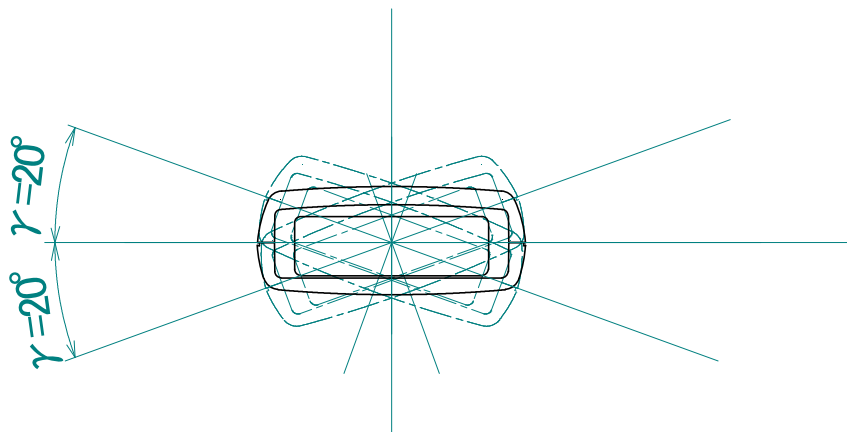

Figure 5: Tilt angle

Conditions

Barcode Sample: OPTOELECTRONICS Test Sample

Distance: 90 mm from the edge of the data collector

Label: **Pitch, Skew Angle**

PCS = 0.9, Resolution = 0.25 mm, Symbology = 9-digit Code 39,
Quiet Zone = 10 mm, N/W Ratio = 1:2.5

Dead Zone, Tilt Angle

PCS = 0.9, Resolution = 0.26 mm, Symbology = 13-digit JAN, Quiet Zone = 10 mm

Angle: Curvature: $R = \infty$, Skew Angle = $\beta + 15^\circ$ (for measuring Pitch Angle and Tilt Angle)

8.5. Curvature

With 8-digit JAN/UPC/EAN barcodes, decoding performance is guaranteed when $R \geq 20$ mm.

With 13-digit JAN/UPC/EAN barcodes, decoding performance is guaranteed when $R \geq 25$ mm.

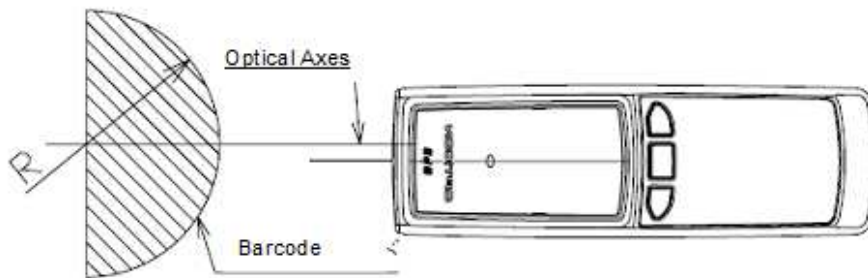

Figure 6: Curvature

Conditions

Barcode Sample: OPTOELECTRONICS Test Sample

PCS = 0.9, Resolution = 0.26 mm, Quiet Zone = 10 mm

Distance: 90 mm from the edge of the data collector

Angle: Skew Angle $\beta = +15^\circ$

The scanning range will vary according to the depth of field.

9. Interface Specifications

9.1. Bluetooth

9.1.1. Module

The OPL 9813 is equipped with a low power fully certified Bluetooth module.

9.1.2. Specifications

Bluetooth standard: 2.1

Bluetooth Class 1.5 (RF output power 2.2 dBm)

Wireless range: 10m indoor (this may vary with the environmental conditions)

Supported profiles: SPP (serial port profile) and HID (keyboard emulation)

9.2. Infrared Transmission (IrDA)

9.2.1. Specifications

Physical interface: According to IrDA Ver1.2 low power specification.

9.2.2. Transmission Speed

Default transmission speed is set at 115.2 kbps. Other supported baud rates are 57.6 kbps, 38.4 kbps, 19.2 kbps, 9600 bps, 4800 bps, and 2400 bps.

9.3. GPS

9.3.1. Module

The OPL 9813 is equipped with a GPS (Global Positioning System) module plus a compact patch antenna (15 mm X 15 mm)

9.3.2. Receiving Frequency

1575.42MHz (L1 C/A Code)

9.3.3. Receiving Channel

66 channels (max)

9.3.4. Sensitivity

Acquisition -148 dBm

Tracking -165 dBm

9.3.5. Time to First Fix (TTFF)

TTFF is the time required for a GPS receiver to acquire satellite signals and navigation data, and calculate a position. It may differ depending on the environmental conditions, such as the number of satellites, obstacles between the satellite and the GPS antenna, or multipath conditions.

- 1 second: Hot Start
- 33 seconds: Warm Start
- 35 seconds: Cold Start

9.3.6. Position-fix Accuracy

3.0 m 2D-RMS

Values may differ, depending on the environmental conditions.

9.3.7. Baud Rate

4800 bps (default) to 115200.

9.3.8. Protocol

NMEA-0183 (Default)

10. Serial Number

10.1. Dimensions and location.

Below is the product label with serial number.

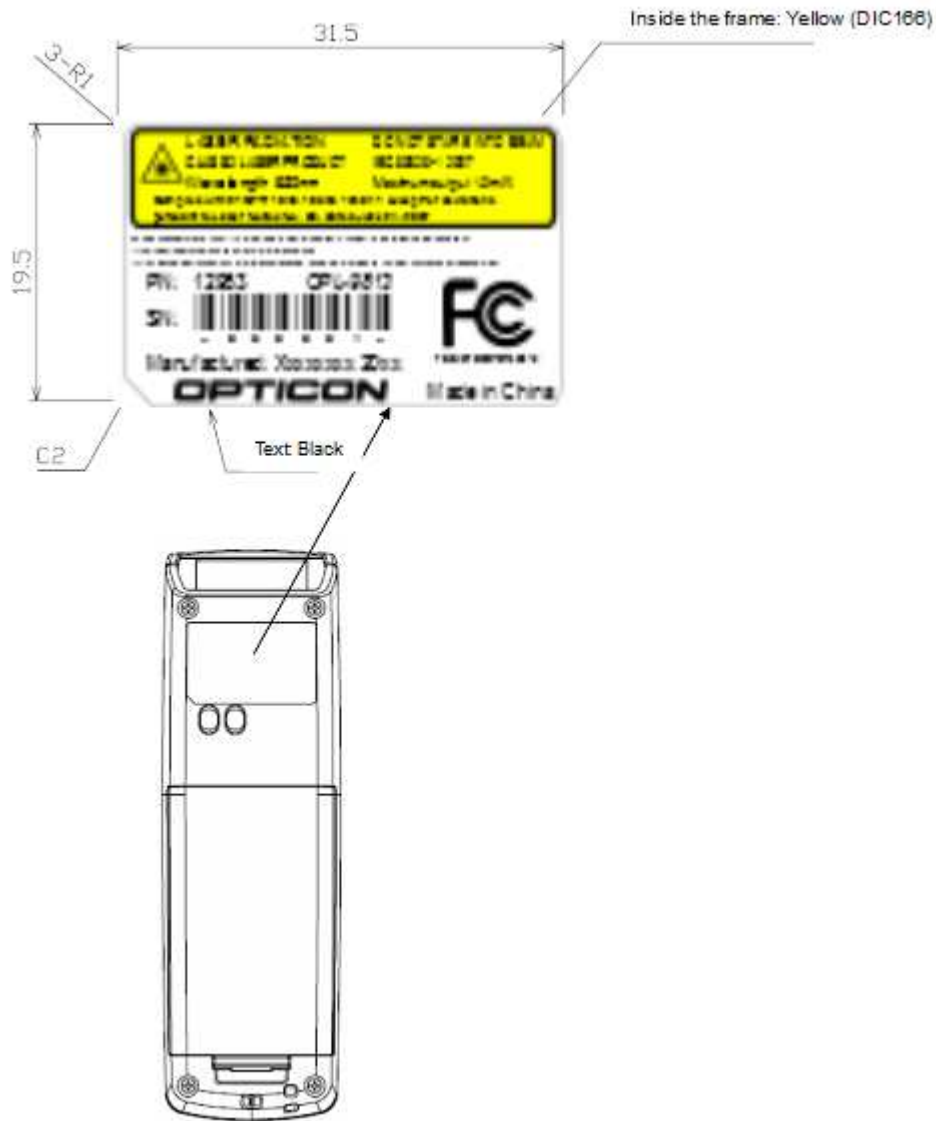

Figure 7: Name plate and serial number

10.2. Detailed drawing

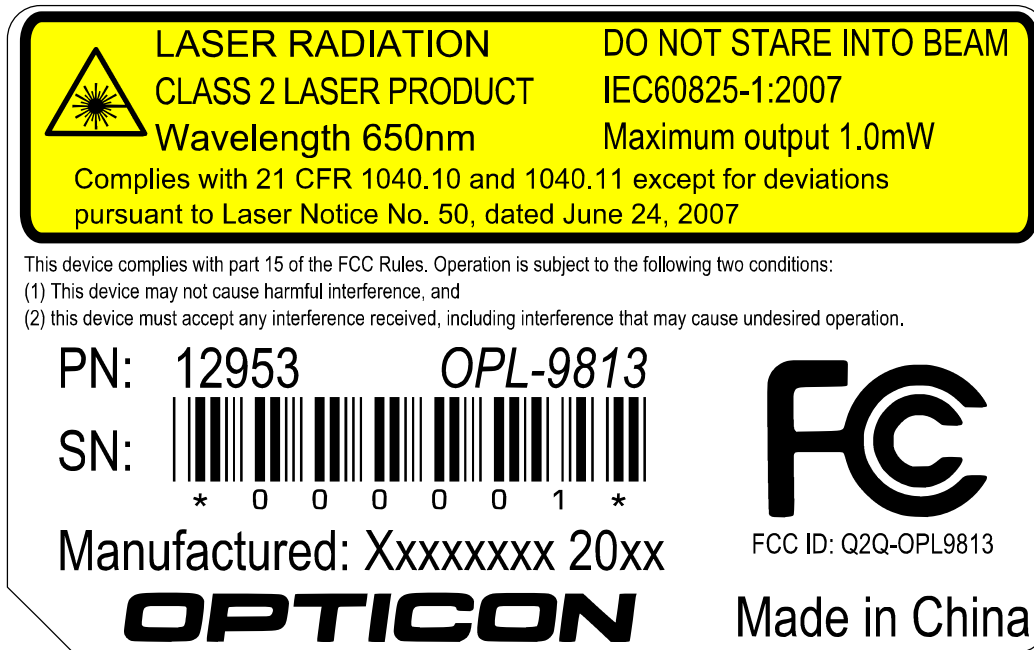

Figure 8: Name plate and serial number details

10.3. Serial number

Bar code: Standard Code 39 plus human readable text printed below the bar code.

Bar code height: 4mm

Bar code data: The serial number. This should match that of the OPL-9813 in the box.

The serial number consists out of 6 digits, starts with 000001 and is incremented with one every unit that is produced.

During production, the serial number is also programmed inside the OPL's non volatile memory. API functions are available to retrieve that number.

10.4. Manufacturing date

The manufacturing date has to be printed on the label and has the following format:

Manufactured: XXXXXXXX 20xx

| | |
|-----------|------|
| January | 2011 |
| February | 2012 |
| March | 2013 |
| April | 2014 |
| May | 2015 |
| June | 2016 |
| July | 2017 |
| August | 2018 |
| September | |
| October | |
| November | |
| December | |

11. Packaging Specifications

11.1. Individual Packaging Specification

Put the data collector in a protective foam bag and place it in an individual packing box, then place the accessories into the box. Close the box and affix a label to the side of the box. Size of the package after assembly: 165 (W) x 65 (D) x 40 (H) mm

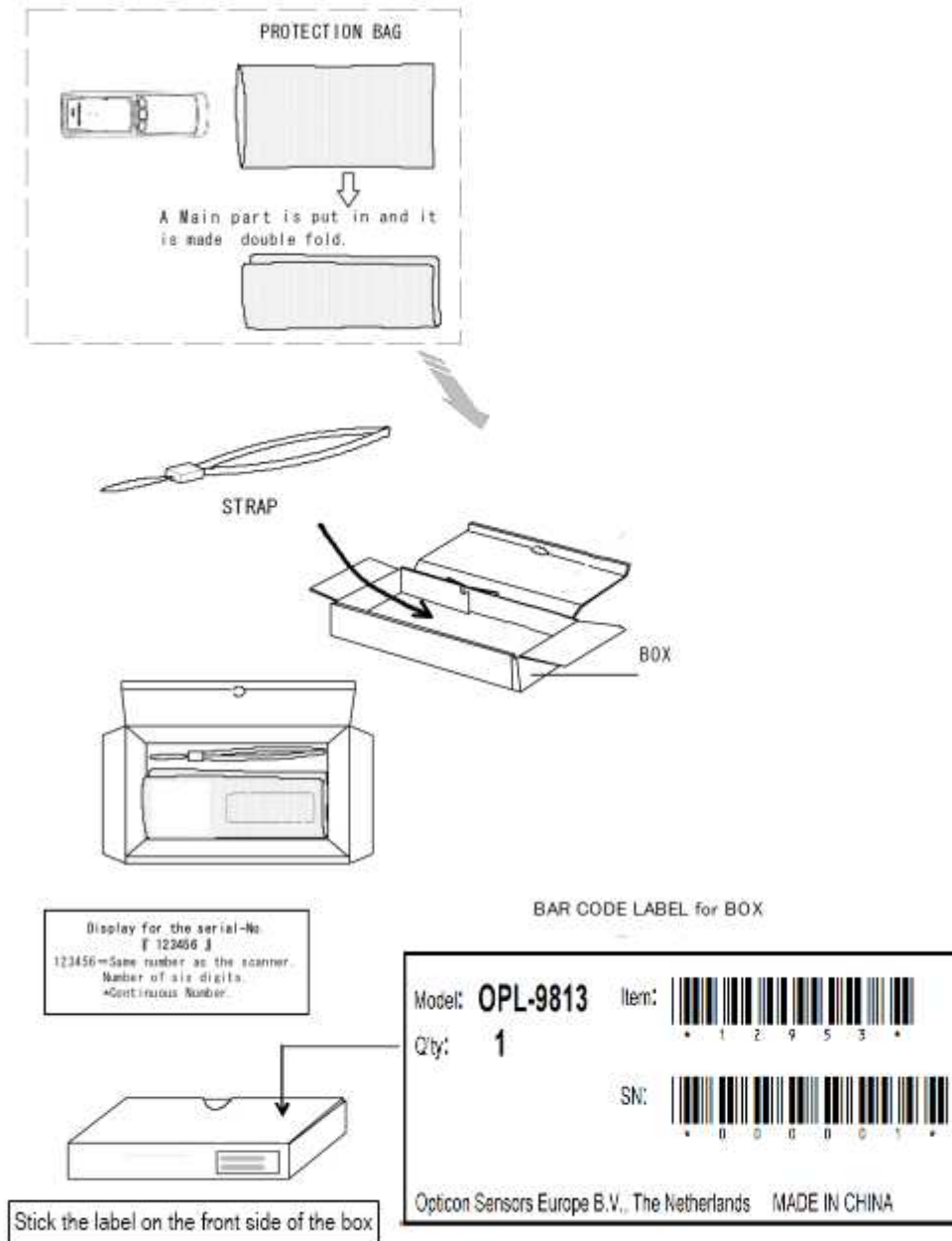

Figure 9: Individual packaging

11.2. Accessory Specification

These accessories are enclosed in an individual package:

- 1 hand strap

11.3. Collective Packaging Specification

Put 135 individually packaged data collectors in a collective packing box.

Dimensions (after assembly): 613 mm (W) by 518 mm (D) by 241 mm (H).

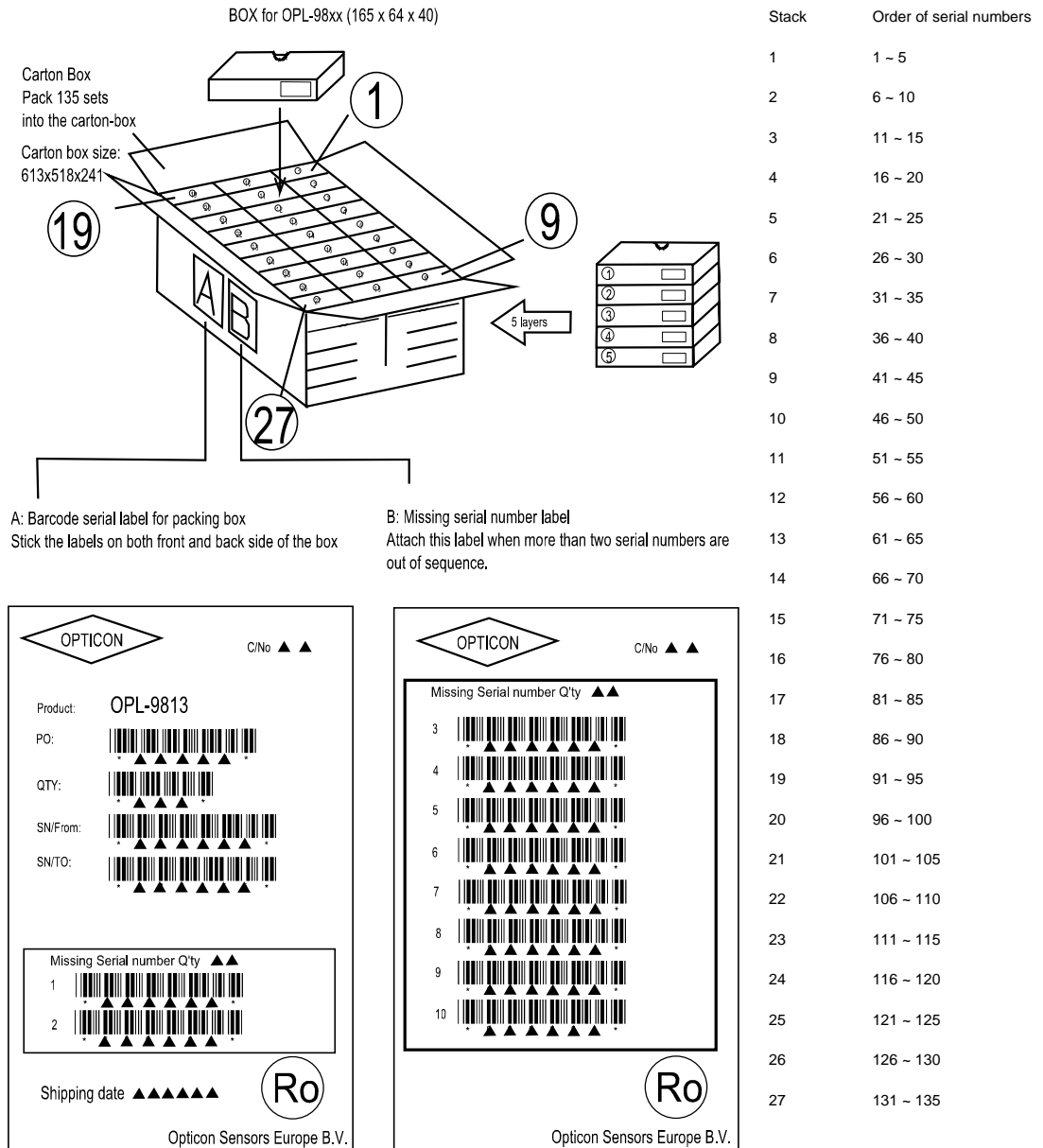

Figure 10: Collective packaging

Note: The “RO” mark labeled on the package tray or package box guarantees that the applicable product has passed our test of RoHS restrictions compliance (the restriction of the use of certain hazardous substances in electrical and electronic equipment, 2002/95 EC). However, this document does **not** have any legal weight in the European Union.

12. Durability

12.1. Drop Test (without packaging)

No malfunction occurred after the following drop test.

Drop Test: Drop the data collector from a height of 150 cm onto a concrete floor. Each side of the data collector impacted the floor three times.

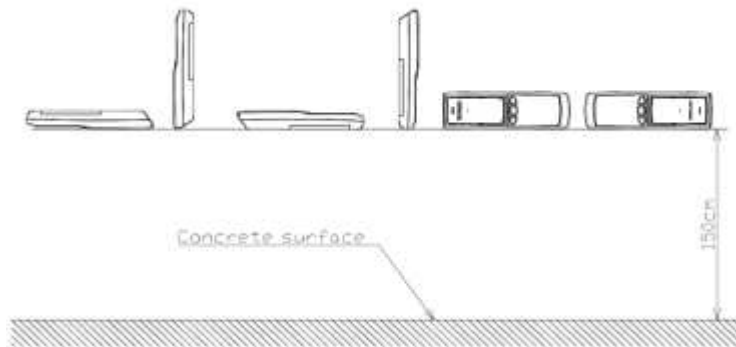

Figure 11: Drop test

12.2. Dust and Drip Proof

IEC IP54

Dust Prevention

| Level | Details |
|-------|---|
| 5 | Ingress of dust is not entirely prevented, but it must not enter in sufficient quantity to interfere with the satisfactory operation of the equipment; complete protection against contact. |

Water Prevention

| Level | Details |
|-------|--|
| 4 | Water splashing against the enclosure from any direction shall have no harmful effect. |

13. Reliability

MTBF (Mean Time Between Failures) of this product is 10,000 hours.

14. Regulatory Compliance

14.1. Laser Safety

The data collector emits laser beams.

JIS C6802: 2005: Laser class 2

IEC 825-1/EN 60825-1: Laser class 2

FDA CDRH Laser class II. Complies with 21 CFR 1040.10 and 1040.11 except for deviations pursuant to laser notice No. 50 dated June 24, 2007.

Class II laser devices are not considered to be hazardous when used for their intended purpose. Avoid staring into the laser beam.

14.2. Certifications

FCC Part 15 Subpart B Class B: This device complies with part 15 of the FCC Rules. Operation is subject to the following two conditions: (1) this device may not cause harmful interference, and (2) this device must accept any interference received, including interference that may cause undesired operation.

FCC Part 15 Subpart C Clause 247 (Spread spectrum radio systems)

Other certifications upon request.

14.3. RoHS

RoHS: The restriction of the use of certain hazardous substances in electrical and electronic equipment, 2002/95 EC.

14.4. State of California: Perchlorate Best Management Practices

The batteries on some Opticon products may contain Perchlorate. To comply with California Perchlorate Best Practice Regulations and the Law for the Promotion of Utilization of Recyclable Resources (Japan), products that may contain Perchlorate materials should be properly labeled on the exterior of all outer shipping packages and/or in locations that otherwise satisfy the California Perchlorate Best Management Practices.

15. Safety

Handle this product carefully. Do not deliberately subject it to any of the following.

15.1. Shock

Do not throw or drop the data collector.

Do not drop or put heavy items on this product.

15.2. Temperature Conditions

Do not use the data collector at temperatures outside the specified range.

Do not use near heat sources such as radiators, heat registers, stoves, or other types of devices that produce heat.

Do not use in areas exposed to direct sunlight for long periods of time.

Do not pinch or forcibly bend the cable, especially at very low temperature.

15.3. Foreign Materials

Do not use the data collector near water or other liquids, as well as in extremely high humidity.

Do not immerse the data collector in liquids.

Do not use in dusty environments.

Do not subject the data collector to chemicals.

Do not insert foreign substances into the device.

15.4. Other

Do not attempt to disassemble, modify or update this device.

Do not use near microwaves, medical devices, or RF-emitting devices.

The data collector may not perform properly in environments when placed near a flickering light, such as a computer monitor, television, etc.

The data collector may be damaged by high voltage discharges.

16. Mechanical Drawing

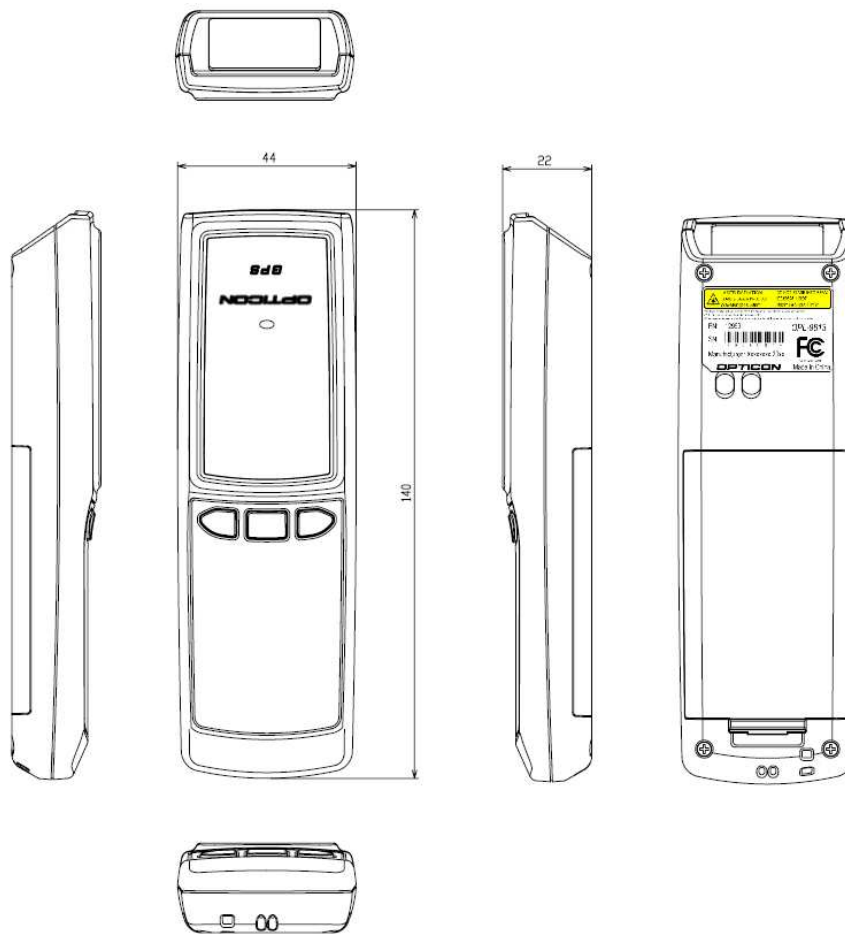

Figure 12: Mechanical drawing