



Valued Quality. Delivered.

TEST REPORT

Report No.: 15090248HKG-003R1

Lenbrook Industries Limited

Application
For
Certification
(Original Grant)
(FCC ID: Q2O-PULSE2)
(IC: 152B-PULSE2)

Transceiver

This report contains the data of Bluetooth 3.0 portion only.

This report supersedes previous report with report number 15090248HKG-003 dated
October 15, 2015

Prepared and Checked by:

Approved by:

Signed On File

Wong Cheuk Ho, Herbert
Lead Engineer

Koo Wai Ip
Assistant Supervisor
Date: September 22, 2016

- Intertek's standard Terms and Conditions can be obtained at our website <http://www.intertek.com/terms/>.
- This report shall not be reproduced, except in full.
- This report is for the exclusive use of Intertek's Client and is provided pursuant to the agreement between Intertek and its Client. Intertek's responsibility and liability are limited to the terms and conditions of the agreement. Intertek assumes no liability to any party, other than to the Client in accordance with the agreement, for any loss, expense or damage occasioned by the use of this report. Only the Client is authorized to permit copying or distribution of this report and then only in its entirety. Any use of the Intertek name or one of its marks for the sale or advertisement of the tested material, product or service must first be approved in writing by Intertek. The observations and test results in this report are relevant only to the sample tested. This report by itself does not imply that the material, product, or service is or has ever been under an Intertek certification program.

Intertek Testing Services Hong Kong Ltd.

2/F., Garment Centre, 576 Castle Peak Road, Kowloon, Hong Kong.
Tel: (852) 2173 8888 Fax: (852) 2785 5487 Website: www.hk.intertek-etlsemko.com

INTERTEK TESTING SERVICES

GENERAL INFORMATION

Grantee:	Lenbrook Industries Limited
Grantee Address:	Room D, 11th Floor, Wing Cheong Commercial Building, 19-25 Jervois Street, Central, Hong Kong.
Contact Person:	Jes Arcenal
Tel:	(852) 2517 8292
Fax:	(852) 2517 4404
e-mail:	Jes_arcenal@nadelectronics.com
Manufacturer:	Lenbrook Industries Limited
Manufacturer Address:	Room D, 11th Floor, Wing Cheong Commercial Building, 19-25 Jervois Street, Central, Hong Kong.
Brand Name:	Bluesound
FCC Model:	PULSE 2
IC Model:	PULSE 2
Type of EUT:	Transceiver
Description of EUT:	All-In-One Compact Wireless Streaming Music System
Serial Number:	N/A
FCC ID / IC:	Q20-PULSE2 / 152B-PULSE2
Date of Sample Submitted:	Sep 14, 2015
Date of Test:	Sep 14, 2015 to Oct 15, 2015
Report No.:	15090248HKG-003R1
Report Date:	September 22, 2016
Environmental Conditions:	Temperature: +10 to 40°C Humidity: 10 to 90%

Report No.: 15090248HKG-003R1

FCC ID: Q20-PULSE2

IC: 152B-PULSE2

Intertek Testing Services Hong Kong Ltd.

2/F., Garment Centre, 576 Castle Peak Road, Kowloon, Hong Kong.
Tel: (852) 2173 8888 Fax: (852) 2785 5487 Website: www.hk.intertek-etlsemko.com

INTERTEK TESTING SERVICES

SUMMARY OF TEST RESULT

TEST SPECIFICATION	REFERENCE	RESULTS
Radiated Emission Radiated Emission on the Bandedge	15.249, 15.209 / RSS-210 A2.9, RSS-210 2.5	Pass
Radiated Emission in Restricted Bands	15.205 / RSS-210 2.2	Pass

The equipment under test is found to be complying with the following standards:
FCC Part 15, October 1, 2014 Edition
RSS-210 Issue 8, December 2010
RSS-Gen Issue 4, November 2014

- Note: 1. The EUT uses a permanently attached antenna which, in accordance to section 15.203, is considered sufficient to comply with the provisions of this section.
2. Pursuant to FCC part 15 Section 15.215(c), the 20 dB bandwidth of the emission was contained within the frequency band designated (mentioned as above) which the EUT operated. The effects, if any, from frequency sweeping, frequency hopping, other modulation techniques and frequency stability over expected variations in temperature and supply voltage were considered.

INTERTEK TESTING SERVICES

Table of Contents

1.0	<u>General Description</u>	1
1.1	Product Description	1
1.2	Related Submittal(s) Grants	2
1.3	Test Methodology	2
1.4	Test Facility	2
2.0	<u>System Test Configuration</u>	3
2.1	Justification	3
2.2	EUT Exercising Software	3
2.3	Special Accessories	3
2.4	Measurement Uncertainty	4
2.5	Support Equipment List and Description	4
3.0	<u>Emission Results</u>	5
3.1	Field Strength Calculation	5
3.2	Radiated Emission Configuration Photograph	6
3.3	Radiated Emission Data	6
4.0	<u>Equipment Photographs</u>	13
5.0	<u>Product Labelling</u>	13
6.0	<u>Technical Specifications</u>	13
7.0	<u>Instruction Manual</u>	13
8.0	<u>Miscellaneous Information</u>	14
8.1	Radiated Emission on the Bandedge	14
8.2	Discussion of Pulse Desensitization	17
8.3	Calculation of Average Factor	17
8.4	Emissions Test Procedures	18
8.5	Occupied Bandwidth	22
9.0	<u>Confidentiality Request</u>	23
10.0	<u>Equipment List</u>	23

INTERTEK TESTING SERVICES

1.0 General Description

1.1 Product Description

The Equipment-Under-Test (EUT) PULSE 2 is an All-In-One Compact Wireless Streaming Music System. The EUT contains both WLAN (WiFi) and Bluetooth modules. The Bluetooth module has Bluetooth 4.0 BLE and Bluetooth 3.0 features. The EUT can accept analog audio signal, digital audio signal and wireless audio signal via Bluetooth devices. An iOS/Android apps Bluesound installed in Smartphone can act as the remote control of the EUT. The EUT has internal power amplifiers and loudspeaker. It is powered by 100-240VAC.

For the WLAN (WiFi) module:

For 802.11b mode, it operates at frequency range of 2412.000MHz to 2462.000MHz with 11 channels. It transmits via direct-sequence spread spectrum (DSSS) modulation. Maximum bit rate can be up to 11Mbps. For 802.11g mode, it operates at frequency range of 2412.000MHz to 2462.000MHz with 11 channels. It transmits via Orthogonal Frequency Division Multiplexing (OFDM) modulation. Maximum bit rate can be up to 54Mbps. For 802.11n (HT20 with 20MHz bandwidth) mode, it operates at frequency range of 2412.000MHz to 2462.000MHz with 11 channels. It transmits via Orthogonal Frequency Division Multiplexing (OFDM) modulation (mcs0 to mcs7). Maximum bit rate can support up to 65Mbps. For 802.11n (HT40 with 40MHz bandwidth) mode, it operates at frequency range of 2422.000MHz to 2452.000MHz with 9 channels. It transmits via Orthogonal Frequency Division Multiplexing (OFDM) modulation (mcs0 to mcs7). Maximum bit rate can support up to 130Mbps.

For Bluetooth module:

For Bluetooth 4.0 BLE mode, it occupies a frequency range from 2402MHz to 2480MHz (40 channels with channel spacing of 2MHz). It transmits via GFSK modulation.

For Bluetooth 3.0 mode, it occupies a frequency range from 2402MHz to 2480MHz (79 channels with channel spacing of 1MHz). It transmits via GFSK modulation.

The antenna(s) used in the EUT is internal, integral.

The circuit description is saved with filename: descri.pdf.

INTERTEK TESTING SERVICES

1.2 Related Submittal(s) Grants

This is a single application for certification of a transceiver (Bluetooth 3.0 only).

1.3 Test Methodology

Both AC mains line-conducted and radiated emission measurements were performed according to the procedures in ANSI C63.10 (2013). All radiated measurements were performed in a 3m Chamber. Preliminary scans were performed in the 3m Chamber only to determine worst case modes. All radiated tests were performed at an antenna to EUT distance of 3 meters, unless stated otherwise in the "Justification Section" of this Application.

1.4 Test Facility

The 3m Chamber and conducted measurement facility used to collect the radiated data is located at Workshop No. 3, G/F., World-Wide Industrial Centre, 43-47 Shan Mei Street, Fo Tan, Sha Tin, N.T., Hong Kong. This test facility and site measurement data have been placed on file with the FCC and IC.

INTERTEK TESTING SERVICES

2.0 System Test Configuration

2.1 Justification

The system was configured for testing in a typical fashion (as a customer would normally use it), and in the confines as outlined in ANSI C63.10 (2013).

The device was powered by 120VAC

For maximizing emissions, the EUT was rotated through 360°, the antenna height was varied from 1 meter to 4 meters above the ground plane, and the antenna polarization was changed. This step by step procedure for maximizing emissions led to the data reported in Exhibit 3.0.

The rear of unit shall be flushed with the rear of the table.

The equipment under test (EUT) was configured for testing in a typical fashion (as a customer would normally use it). The EUT was mounted to a plastic stand if necessary and placed on the wooden turntable, which enabled the engineer to maximize emissions through its placement in the three orthogonal axes.

Different data rates have been tested. Worst case is reported only.

All relevant operation modes have been tested, and the worst case data is included in this report.

All data rates were tested under normal mode of Bluetooth 3.0. Only the worst-case data is shown in the report for GFSK.

For simultaneous transmission, both WiFi and Bluetooth portions are also switched on when taking radiated emission for determining worst-case spurious emission.

2.2 EUT Exercising Software

The EUT exercise program (if any) used during radiated and conducted testing was designed to exercise the various system components in a manner similar to a typical use.

2.3 Special Accessories

There are no special accessories necessary for compliance of this product.

INTERTEK TESTING SERVICES

2.4 Measurement Uncertainty

When determining of the test conclusion, the Measurement Uncertainty of test has been considered.

2.5 Support Equipment List and Description

- (1) 1 X power cable of 1.8m in length
(Supplied by Applicant)
- (2) 1 X audio cable of 2m in length (with termination)
- (3) 1 X LAN cable of 2m in length (with termination)
- (4) 1 X 4GB USB flash drive
(Supplied by Intertek)

INTERTEK TESTING SERVICES

3.0 Emission Results

Data is included of the worst case configuration (the configuration which resulted in the highest emission levels). A sample calculation, configuration photographs and data tables of the emissions are included.

3.1 Field Strength Calculation

The field strength is calculated by adding the Antenna Factor and Cable Factor, and subtracting the Amplifier Gain (if any), Average Factor (optional) from the measured reading. The basic equation with a sample calculation is as follows:

$$FS = RA + AF + CF - AG - AV$$

where

- FS = Field Strength in dB μ V/m
- RA = Receiver Amplitude (including preamplifier) in dB μ V
- CF = Cable Attenuation Factor in dB
- AF = Antenna Factor in dB
- AG = Amplifier Gain in dB
- AV = Average Factor in dB

In the following table(s), the reading shown on the data table reflects the preamplifier gain. An example for the calculations in the following table is as follows:

$$FS = RR + LF$$

where

- FS = Field Strength in dB μ V/m
- RR = RA - AG - AV in dB μ V
- LF = CF + AF in dB

Assume a receiver reading of 52.0 dB μ V is obtained. The antenna factor of 7.4 dB and cable factor of 1.6 dB are added. The amplifier gain of 29 dB and average factor of 5 dB are subtracted, giving a field strength of 32 dB μ V/m. This value in dB μ V/m was converted to its corresponding level in μ V/m.

RA = 52.0 dB μ V/m	
AF = 7.4 dB	RR = 18.0 dB μ V
CF = 1.6 dB	LF = 9.0 dB
AG = 29.0 dB	
AV = 5.0 dB	
FS = RR + LF	
FS = 18 + 9 = 27 dB μ V/m	

$$\text{Level in } \mu\text{V/m} = \text{Common Antilogarithm } [(27 \text{ dB}\mu\text{V/m})/20] = 22.4 \mu\text{V/m}$$

INTERTEK TESTING SERVICES

3.2 Radiated Emission Configuration Photograph

The worst case in radiated emission was found at 250.008 MHz

For electronic filing, the worst case radiated emission configuration photographs are saved with filename: radiated photos.pdf.

3.3 Radiated Emission Data

The data on the following page lists the significant emission frequencies, the limit and the margin of compliance. Numbers with a minus sign are below the limit.

Judgment: Passed by 0.8 dB

3.4 Conducted Emission Configuration Photograph

The worst case in line-conducted emission was found at 0.843 MHz

For electronic filing, the worst case line-conducted configuration photographs are saved with filename: conducted photo.pdf.

3.5 Conducted Emission Data

For electronic filing, the graph and data table of conducted emission is saved with filename: conducted.pdf.

Judgment: Pass by 8.5 dB

INTERTEK TESTING SERVICES

Model: PULSE 2

Worst Case: EUT Transmitting (WiFi + Bluetooth simultaneously)

EDIT PEAK LIST (Final Measurement Results)				
Trace1:	CF15MQP			
Trace2:	CF15MAV			
Trace3:	---			
TRACE	FREQUENCY	LEVEL dBμV		DELTA LIMIT dB
1 Quasi Peak	150 kHz	56.42	N	-9.57
2 CISPR Average	186 kHz	44.20	L1	-10.00
1 Quasi Peak	213 kHz	45.15	L1	-17.93
2 CISPR Average	226.5 kHz	36.68	L1	-15.88
1 Quasi Peak	370.5 kHz	43.73	L1	-14.75
2 CISPR Average	370.5 kHz	37.76	L1	-10.72
1 Quasi Peak	433.5 kHz	48.66	L1	-8.52
2 CISPR Average	460.5 kHz	35.95	L1	-10.72
1 Quasi Peak	699 kHz	39.84	N	-16.15
2 CISPR Average	780 kHz	31.77	N	-14.22
2 CISPR Average	843 kHz	37.49	N	-8.50
1 Quasi Peak	1.023 MHz	41.99	N	-14.00
1 Quasi Peak	1.0995 MHz	41.41	N	-14.58
2 CISPR Average	1.437 MHz	33.26	N	-12.73
2 CISPR Average	1.797 MHz	35.18	N	-10.81
1 Quasi Peak	1.8015 MHz	45.22	N	-10.77
1 Quasi Peak	2.2965 MHz	45.70	N	-10.29
2 CISPR Average	2.7915 MHz	35.51	N	-10.48
2 CISPR Average	3.0975 MHz	35.58	N	-10.41
1 Quasi Peak	3.372 MHz	44.19	N	-11.81

EDIT PEAK LIST (Final Measurement Results)				
Trace1:	CF15MQP			
Trace2:	CF15MAV			
Trace3:	---			
TRACE	FREQUENCY	LEVEL dBμV		DELTA LIMIT dB
2 CISPR Average	4.146 MHz	32.80	L1	-13.19
1 Quasi Peak	4.191 MHz	38.15	N	-17.84
2 CISPR Average	17.295 MHz	31.98	N	-18.01
1 Quasi Peak	17.34 MHz	35.56	L1	-24.43
1 Quasi Peak	29.949 MHz	35.85	L1	-24.14
2 CISPR Average	29.9535 MHz	33.44	L1	-16.55

Note: Measurement Uncertainty is ± 4.2 dB at a level of confidence of 95%.

INTERTEK TESTING SERVICES

Worst Case: EUT Transmitting (WiFi + Bluetooth simultaneously)

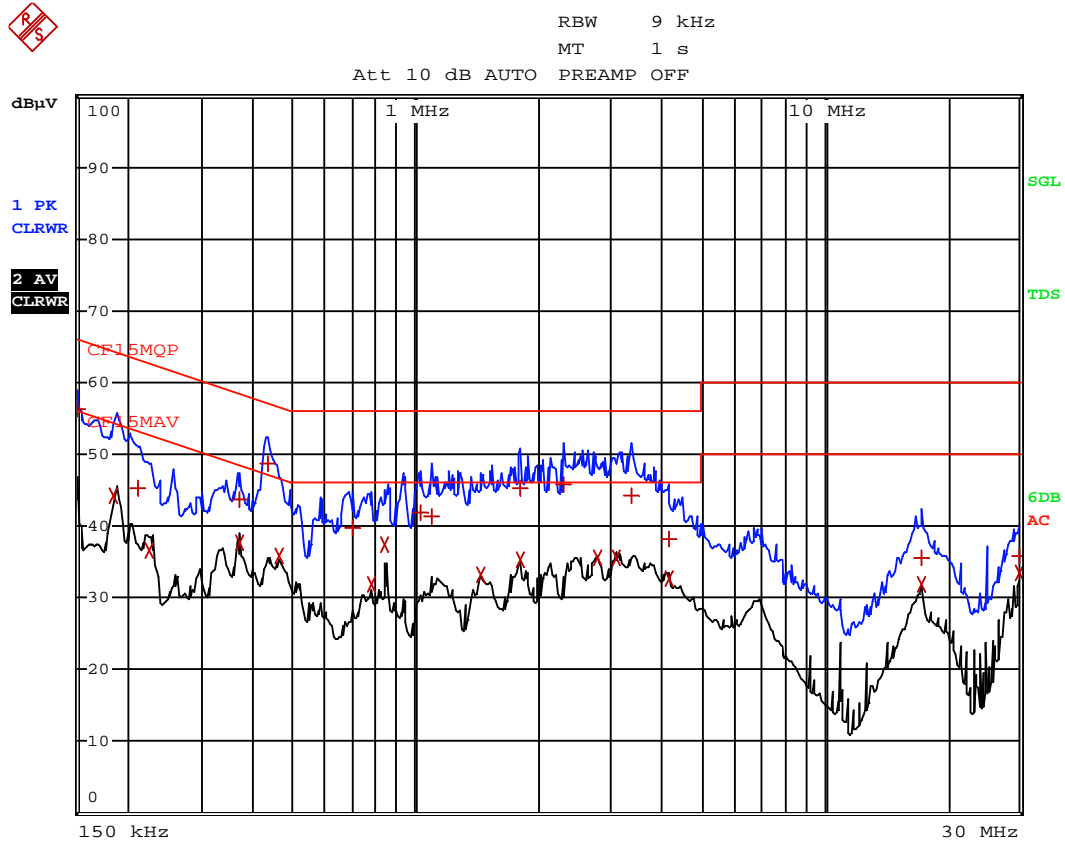

Date: 15.OCT.2015 13:21:34

Conducted Emission Test Setup

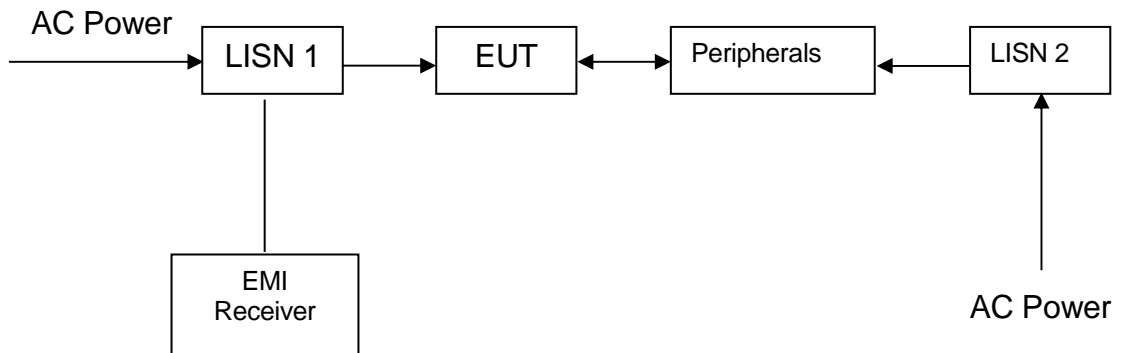

Report No.: 15090248HKG-003R1

FCC ID: Q20-PULSE2

IC: 152B-PULSE2

8

Intertek Testing Services Hong Kong Ltd.

2/F., Garment Centre, 576 Castle Peak Road, Kowloon, Hong Kong.
Tel: (852) 2173 8888 Fax: (852) 2785 5487 Website: www.hk.intertek-etlsemko.com

INTERTEK TESTING SERVICES

Applicant: Lenbrook Industries Limited

Date of Test: OCT 9, 2015

Model: PULSE 2

Worst-Case Operating Mode: Transmitting (Bluetooth 3.0)

Table 1
Radiated Emissions
Pursuant to FCC Part 15 Section 15.249 / RSS-210 A2.9 Requirement

Lowest Channel

Polarization	Frequency (MHz)	Reading (dBμV)	Pre-Amp Gain (dB)	Antenna Factor (dB)	Net at 3m - Peak (dBμV/m)	Average Factor (dB)	Calculated at 3m (dBμV/m)	Average Limit at 3m (dBμV/m)	Margin (dB)
V	2402.000	102.4	33	29.4	98.8	24	74.8	94.0	-19.2
V	4804.000	49.3	33	34.9	51.2	24	27.2	54.0	-26.8
V	7206.000	46.3	33	37.9	51.2	24	27.2	54.0	-26.8
V	9608.000	43.8	33	40.4	51.2	24	27.2	54.0	-26.8
V	12010.000	43.9	33	40.5	51.4	24	27.4	54.0	-26.6
V	14412.000	44.2	33	40.0	51.2	24	27.2	54.0	-26.8

Polarization	Frequency (MHz)	Reading (dBμV)	Pre-Amp Gain (dB)	Antenna Factor (dB)	Net at 3m - Peak (dBμV/m)	Peak Limit at 3m (dBμV/m)	Margin (dB)
V	2402.000	102.4	33	29.4	98.8	114.0	-15.2
V	4804.000	49.3	33	34.9	51.2	74.0	-22.8
V	7206.000	46.3	33	37.9	51.2	74.0	-22.8
V	9608.000	43.8	33	40.4	51.2	74.0	-22.8
V	12010.000	43.9	33	40.5	51.4	74.0	-22.6
V	14412.000	44.2	33	40.0	51.2	74.0	-22.8

NOTES: 1. Peak Detector Data unless otherwise stated.

2. All measurements were made at 3 meters. Harmonic emissions not detected at the 3-meter distances were measured at 0.3-meter and an inverse proportional extrapolation was performed to compare the signal level to the 3-meter limit. No other harmonic emissions than those reported were detected at a test distance of 0.3-meter.
3. Negative sign in the column shows value below limit.
4. Horn antenna is used for the emission over 1000MHz.
5. Emission (the row indicated by **bold italic**) within the restricted band meets the requirement of FCC Part 15 Section 15.205 / RSS-210 Section 2.2.
6. Measurement Uncertainty is ±5.3dB at a level of confidence of 95%.

INTERTEK TESTING SERVICES

Applicant: Lenbrook Industries Limited

Date of Test: OCT 9, 2015

Model: PULSE 2

Worst-Case Operating Mode: Transmitting (Bluetooth 3.0)

Table 2
Radiated Emissions
Pursuant to FCC Part 15 Section 15.249 / RSS-210 A2.9 Requirement

Middle Channel

Polarization	Frequency (MHz)	Reading (dB μ V)	Pre-Amp Gain (dB)	Antenna Factor (dB)	Net at 3m - Peak (dB μ V/m)	Average Factor (dB)	Calculated at 3m (dB μ V/m)	Average Limit at 3m (dB μ V/m)	Margin (dB)
V	2442.000	101.8	33	29.4	98.2	24	74.2	94.0	-19.8
V	4884.000	49.3	33	34.9	51.2	24	27.2	54.0	-26.8
V	7326.000	46.5	33	37.9	51.4	24	27.4	54.0	-26.6
V	9768.000	44.0	33	40.4	51.4	24	27.4	54.0	-26.6
V	12210.000	43.9	33	40.5	51.4	24	27.4	54.0	-26.6
V	14652.000	46.1	33	38.4	51.5	24	27.5	54.0	-26.6

Polarization	Frequency (MHz)	Reading (dB μ V)	Pre-Amp Gain (dB)	Antenna Factor (dB)	Net at 3m - Peak (dB μ V/m)	Peak Limit at 3m (dB μ V/m)	Margin (dB)
V	2442.000	101.8	33	29.4	98.2	114.0	-15.8
V	4884.000	49.3	33	34.9	51.2	74.0	-22.8
V	7326.000	46.5	33	37.9	51.4	74.0	-22.6
V	9768.000	44.0	33	40.4	51.4	74.0	-22.6
V	12210.000	43.9	33	40.5	51.4	74.0	-22.6
V	14652.000	46.1	33	38.4	51.5	74.0	-22.5

NOTES: 1. Peak Detector Data unless otherwise stated.

2. All measurements were made at 3 meters. Harmonic emissions not detected at the 3-meter distances were measured at 0.3-meter and an inverse proportional extrapolation was performed to compare the signal level to the 3-meter limit. No other harmonic emissions than those reported were detected at a test distance of 0.3-meter.
3. Negative sign in the column shows value below limit.
4. Horn antenna is used for the emission over 1000MHz.
5. Emission (the row indicated by **bold italic**) within the restricted band meets the requirement of FCC Part 15 Section 15.205 / RSS-210 Section 2.2.
6. Measurement Uncertainty is ± 5.3 dB at a level of confidence of 95%.

INTERTEK TESTING SERVICES

Applicant: Lenbrook Industries Limited

Date of Test: OCT 9, 2015

Model: PULSE 2

Worst-Case Operating Mode: Transmitting (Bluetooth 3.0)

Table 3
Radiated Emissions
Pursuant to FCC Part 15 Section 15.249 / RSS-210 A2.9 Requirement

Highest Channel

Polarization	Frequency (MHz)	Reading (dBμV)	Pre-Amp Gain (dB)	Antenna Factor (dB)	Net at 3m - Peak (dBμV/m)	Average Factor (dB)	Calculated at 3m (dBμV/m)	Average Limit at 3m (dBμV/m)	Margin (dB)
V	2480.000	101.4	33	29.4	97.8	24	73.8	94.0	-20.2
V	4960.000	49.3	33	34.9	51.2	24	27.2	54.0	-26.8
V	7440.000	46.5	33	37.9	51.4	24	27.4	54.0	-26.6
V	9920.000	44.0	33	40.4	51.4	24	27.4	54.0	-26.6
V	12400.000	43.7	33	40.5	51.2	24	27.2	54.0	-26.8
V	14880.000	45.8	33	38.4	51.2	24	27.2	54.0	-26.8

Polarization	Frequency (MHz)	Reading (dBμV)	Pre-Amp Gain (dB)	Antenna Factor (dB)	Net at 3m - Peak (dBμV/m)	Peak Limit at 3m (dBμV/m)	Margin (dB)
V	2480.000	101.4	33	29.4	97.8	114.0	-16.2
V	4960.000	49.3	33	34.9	51.2	74.0	-22.8
V	7440.000	46.5	33	37.9	51.4	74.0	-22.6
V	9920.000	44.0	33	40.4	51.4	74.0	-22.6
V	12400.000	43.7	33	40.5	51.2	74.0	-22.8
V	14880.000	45.8	33	38.4	51.2	74.0	-22.8

NOTES: 1. Peak Detector Data unless otherwise stated.

2. All measurements were made at 3 meters. Harmonic emissions not detected at the 3-meter distances were measured at 0.3-meter and an inverse proportional extrapolation was performed to compare the signal level to the 3-meter limit. No other harmonic emissions than those reported were detected at a test distance of 0.3-meter.
3. Negative sign in the column shows value below limit.
4. Horn antenna is used for the emission over 1000MHz.
5. Emission (the row indicated by **bold italic**) within the restricted band meets the requirement of FCC Part 15 Section 15.205 / RSS-210 Section 2.2.
6. Measurement Uncertainty is ± 5.3 dB at a level of confidence of 95%.

INTERTEK TESTING SERVICES

Applicant: Lenbrook Industries Limited

Date of Test: OCT 9, 2015

Model: PULSE 2

Worst-Case Operating Mode: EUT Transmitting (WiFi + Bluetooth simultaneously)

Table 4

Radiated Emission Data

Polarization	Frequency (MHz)	Reading (dB μ V)	Pre-amp (dB)	Antenna Factor (dB)	Net at 3m (dB μ V/m)	Limit at 3m (dB μ V/m)	Margin (dB)
V	150.002	36.0	16	14.0	34.0	43.5	-9.5
V	160.325	34.5	16	16.0	34.5	43.5	-9.0
V	175.006	32.0	16	19.0	35.0	43.5	-8.5
V	187.632	35.5	16	16.0	35.5	43.5	-8.0
V	212.356	38.0	16	17.0	39.0	43.5	-4.5
V	250.008	41.2	16	20.0	45.2	46.0	-0.8
V	255.065	34.4	16	21.0	39.4	46.0	-6.6
V	290.154	31.6	16	22.0	37.6	46.0	-8.4
V	375.023	31.4	16	24.0	39.4	46.0	-6.6
V	450.034	27.8	16	26.0	37.8	46.0	-8.2
V	625.045	21.9	16	29.0	34.9	46.0	-11.1
V	750.054	21.0	16	30.0	35.0	46.0	-11.0

- NOTES:
1. Peak detector is used for the emission measurement.
 2. All measurements were made at 3 meters. Radiated emissions not detected at the 3-meter distance were measured at 0.3-meter and an inverse proportional extrapolation was performed to compare the signal level to the 3-meter limit. No other radiated emissions than those reported were detected at a test distance of 0.3-meter.
 3. Negative value in the margin column shows emission below limit.
 4. Emission (the row indicated by **bold italic**) within the restricted band meets the requirement of FCC Part 15 Section 15.205 / RSS-210 Section 2.2.
 5. Measurement Uncertainty is ± 5.3 dB at a level of confidence of 95%.

INTERTEK TESTING SERVICES

4.0 **Equipment Photographs**

For electronic filing, the photographs are saved with filename: external photos.pdf and internal photos.pdf.

5.0 **Product Labelling**

For electronics filing, the FCC ID label artwork and the label location are saved with filename: label.pdf.

6.0 **Technical Specifications**

For electronic filing, the block diagram and schematic of the tested EUT are saved with filename: block.pdf and circuit.pdf respectively.

7.0 **Instruction Manual**

For electronic filing, a preliminary copy of the Instruction Manual is saved with filename: manual.pdf.

This manual will be provided to the end-user with each unit sold/leased in the United States and Canada.

8.0 **Miscellaneous Information**

The miscellaneous information includes details of the test procedure and measured bandwidth / calculation of factor such as pulse desensitization and averaging factor (calculation and timing diagram).

8.1 Radiated Emission on the Bandedge

From the following plots, they show that the fundamental emissions are confined in the specified band (2400MHz to 2483.5MHz). In case of the fundamental emissions are within two standard bandwidths from the bandedge, the delta measurement technique is used for determining bandedge compliance. Standard bandwidth is the bandwidth specified by ANSI C63.10 (2013) for frequency being measured.

Emissions radiated outside of the specified frequency bands, except harmonics, are attenuated by 50dB below the level of the fundamental or to the general radiated emissions limits in Section 15.209 / RSS-210 2.5, whichever is the lesser attenuation, which meet the requirement of part 15.249(d) / RSS-210 A2.9.

INTERTEK TESTING SERVICES

Peak Measurement (Bluetooth 3.0)

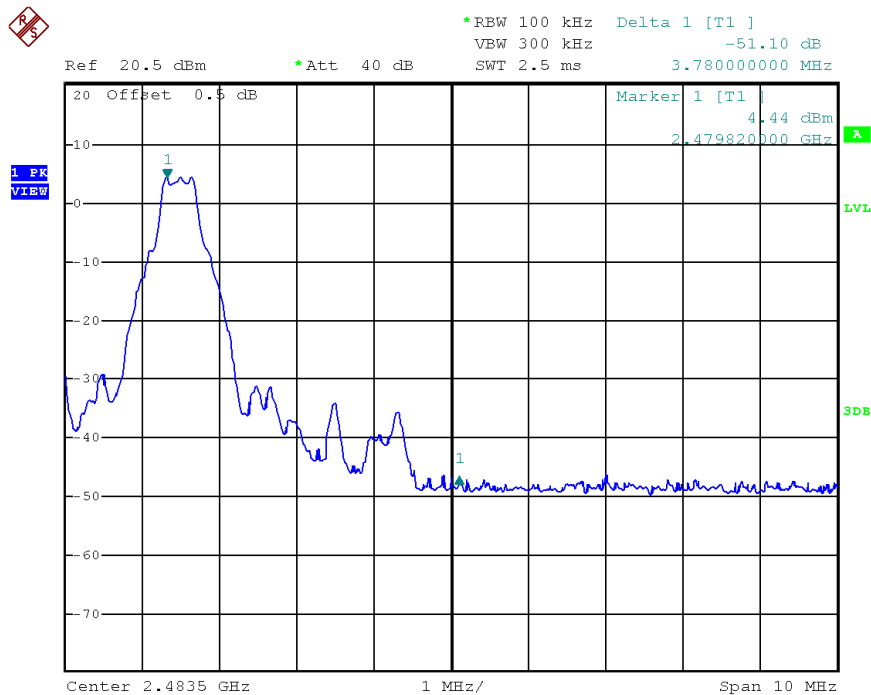
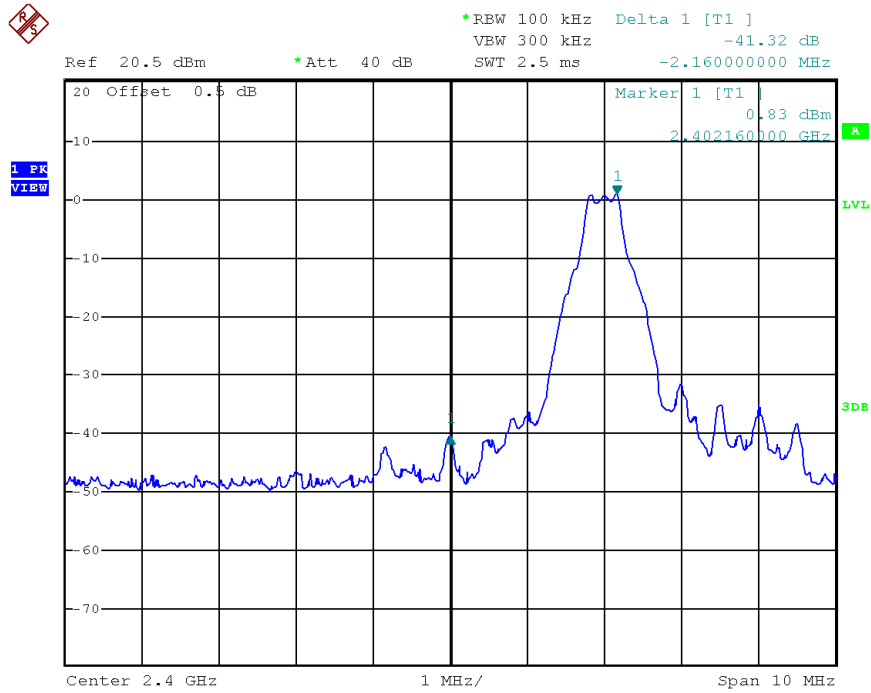

INTERTEK TESTING SERVICES

Peak Measurement (Bluetooth 3.0)

Bandedge compliance is determined by applying marker-delta method, i.e. (Bandedge Plot).

Lower bandedge

Peak Resultant field strength = Fundamental emissions (peak value) – delta from the plot

=98.8 dB μ V/m – 41.3 dB

=57.5 dB μ V/m

Average Resultant field strength = Fundamental emissions (average value) – delta from the plot

=74.8 dB μ V/m – 41.3 dB

=33.5 dB μ V/m

Upper bandedge

Peak Resultant field strength = Fundamental emissions (peak value) – delta from the plot

=97.8 dB μ V/m – 51.1 dB

=46.7 dB μ V/m

Average Resultant field strength = Fundamental emissions (average value) – delta from the plot

=73.8 dB μ V/m – 51.1 dB

=22.7 dB μ V/m

The resultant field strength meets the general radiated emission limit in Section 15.209, which does not exceed 74 dB μ V/m (Peak Limit) and 54 dB μ V/m (Average Limit).

INTERTEK TESTING SERVICES

8.2 Discussion of Pulse Desensitization

Pulse desensitivity is not applicable for this device. The effective period (Teff) is approximately 0.625ms for a digital "1" bit which illustrated on technical specification, with a resolution bandwidth (3dB) of 1MHz, so the pulse desensitivity factor is 0dB.

8.3 Calculation of Average Factor

Based on the Bluetooth Specification Version 3.0 + EDR, the transmitter ON time for each timeslot of Bluetooth is 625 μ s. DH5 has the maximum duty cycle, which consists of 5 continuous Tx slots and 1 Rx slot. Therefore one hopset take $(5+1) \times 625\mu\text{s} = 3.75\text{ms}$. For one period for a pseudo-random hopping through at least 20 RF channels in adaptive mode (worse case), it take: $20 \times 3.75\text{ms} = 75\text{ms}$.

The dwell time for DH5 is $5 \times 625\mu\text{s} = 3.125\text{ms}$.

For the worst case calculation, there are two transmissions might occur in 100ms. Therefore,

$$\begin{aligned}\text{Duty Cycle (DC)} &= \text{Maximum On time in } 100\text{ms}/100\text{ms} \\ &= 3.125\text{ms} \times 2/100\text{ms} \\ &= 0.0625\end{aligned}$$

$$\begin{aligned}\text{Average Factor (AF) of Bluetooth in dB} &= 20 \log_{10} (0.0625) \\ &= -24 \text{ dB}\end{aligned}$$

INTERTEK TESTING SERVICES

8.4 Emissions Test Procedures

The following is a description of the test procedure used by Intertek Testing Services Hong Kong Ltd. in the measurements of transmitter operating under the Part 15, Subpart C rules.

The transmitting equipment under test (EUT) is placed on a wooden turntable which is four feet in diameter and approximately 0.8m in height above the ground plane for emission measurement at or below 1GHz and 1.5m in height above the ground plane for emission measurement above 1GHz. During the radiated emissions test, the turntable is rotated and any cables leaving the EUT are manipulated to find the configuration resulting in maximum emissions. The EUT is adjusted through all three orthogonal axis to obtain maximum emission levels. The antenna height and polarization are also varied during the testing to search for maximum signal levels. The height of the antenna is varied from one to four meters.

Detector function for radiated emissions is in peak mode. Average readings, when required, are taken by measuring the duty cycle of the equipment under test and subtracting the corresponding amount in dB from the measured peak readings. A detailed description for the calculation of the average factor can be found in Exhibit 8.3.

The frequency range scanned is from the lowest radio frequency signal generated in the device which is greater than 9 kHz to the tenth harmonic of the highest fundamental frequency or 40 GHz, whichever is lower.

INTERTEK TESTING SERVICES

8.4 Emissions Test Procedures (cont'd)

The EUT is warmed up for 15 minutes prior to the test.

AC power to the unit is varied from 85% to 115% nominal and variation in the fundamental emission field strength is recorded. If battery powered, a new, fully charged battery is used.

Conducted measurements were made as described in ANSI C63.10 (2013).

The IF bandwidth used for measurement of radiated signal strength was 100 kHz or greater when frequency is below 1000 MHz. Where pulsed transmissions of short enough pulse duration warrant, a greater bandwidth is selected according to the recommendations of Hewlett Packard Application Note 150-2. A discussion of whether pulse desensitivity is applicable to this unit is included in this report (See Exhibit 8.1). Above 1000 MHz, a resolution bandwidth of 1 MHz is used.

Transmitter measurements are normally conducted at a measurement distance of three meters. However, to assure low enough noise floor in the forbidden bands and above 1 GHz, signals are acquired at a distance of one meter or less. All measurements are extrapolated to three meters using inverse scaling, unless otherwise reported. Measurements taken at a closer distance are so marked.

INTERTEK TESTING SERVICES

8.4.1 Radiated Emission Test Setup

The figure below shows the test setup, which is utilized to make these measurements.

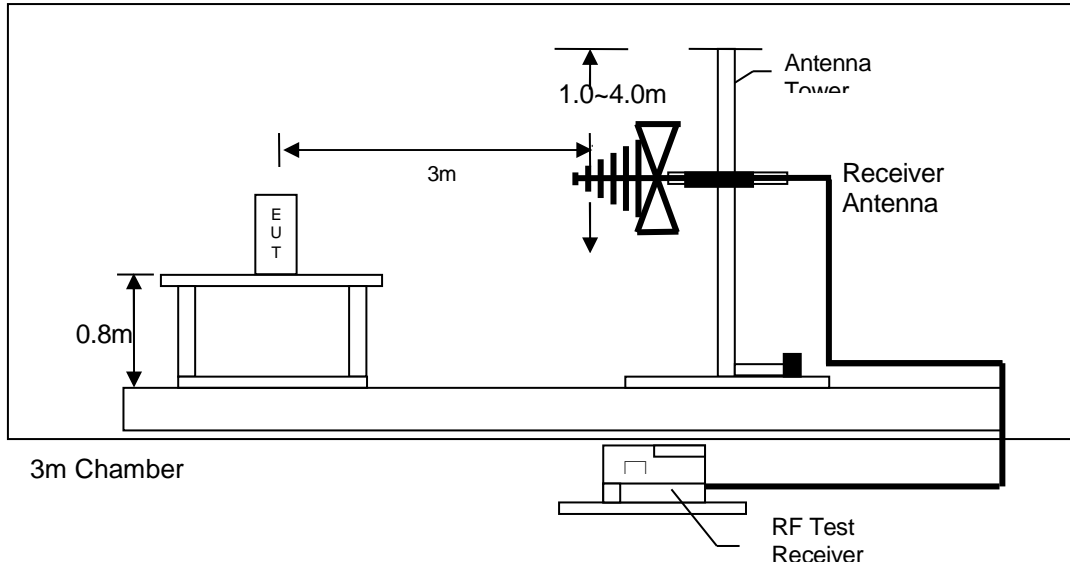

Test setup of radiated emissions up to 1GHz

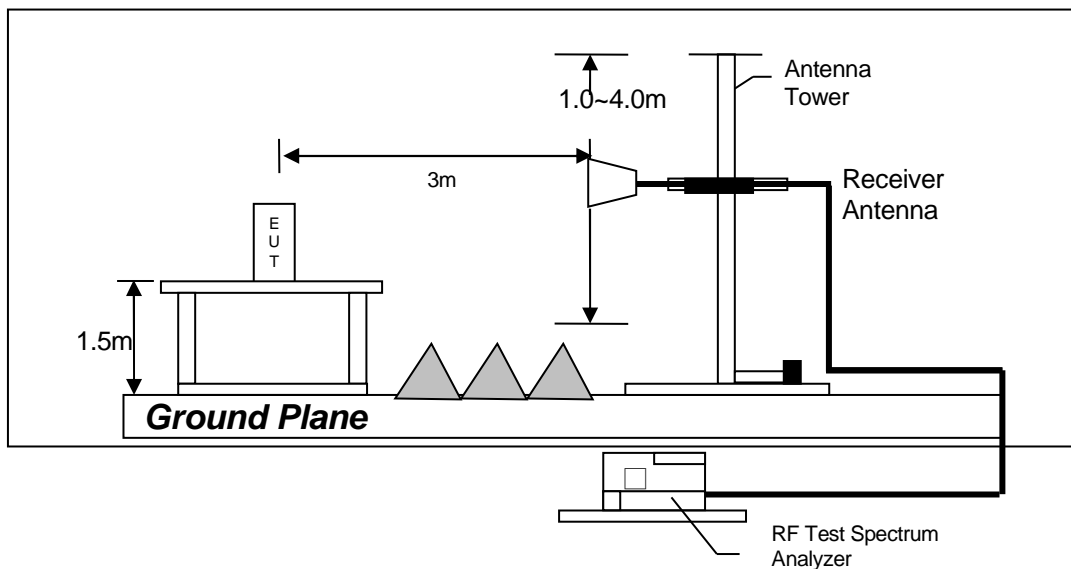

Test setup of radiated emissions above 1GHz

8.4.2 Conducted Emission Test Procedures

INTERTEK TESTING SERVICES

For tabletop equipment, the EUT along with its peripherals were placed on a 1.0m(W)×1.5m(L) and 0.8m in height wooden table. For floor-standing equipment, the EUT and all cables were insulated, if required, from the ground plane by up to 12 mm of insulating material. The EUT was adjusted to maintain a 0.4 meter space from a vertical reference plane. The EUT was connected to power mains through a line impedance stabilization network (LISN), which provided 50 ohm coupling impedance for measuring instrument and the chassis ground was bounded to the horizontal ground plane of shielded room. The excess power cable between the EUT and the LISN was bundled.

All connecting cables of EUT and peripherals were moved to find the maximum emission.

8.4.3 Conducted Emission Test Setup

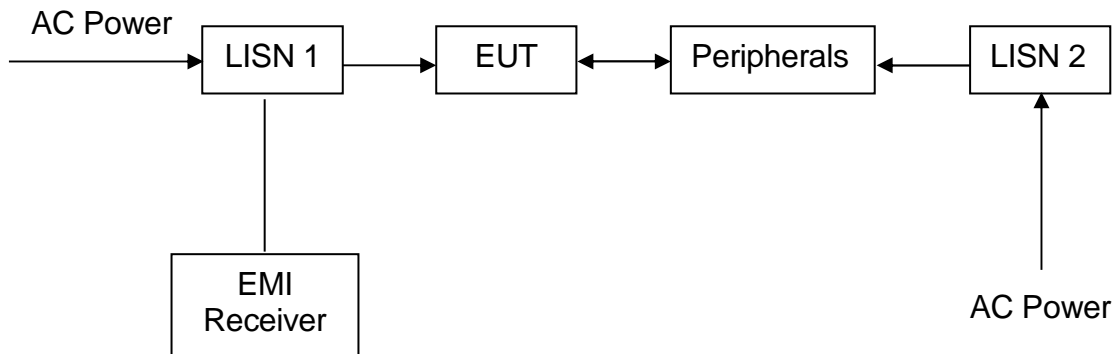

INTERTEK TESTING SERVICES

8.5 Occupied Bandwidth

Occupied Bandwidth Results: (Bluetooth 3.0)

Bluetooth	Occupied Bandwidth (kHz)
Low Channel: 2402	850
Middle Channel: 2442	850
High Channel: 2480	840

The worst case is shown as below:

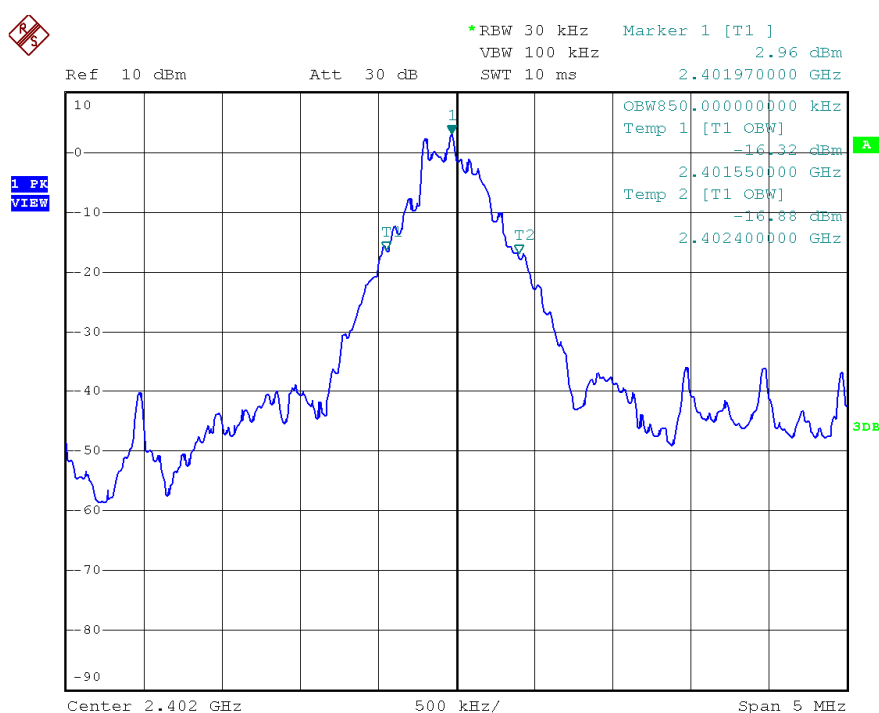

INTERTEK TESTING SERVICES

9.0 **Confidentiality Request**

For electronic filing, a preliminary copy of the confidentiality request is saved with filename: request.pdf.

10.0 **Equipment List**

1) Radiated Emissions Test

Equipment	EMI Test Receiver	Spectrum Analyzer	Biconical Antenna
Registration No.	EW-3095	EW-2249	EW-2512
Manufacturer	R&S	R&S	EMCO
Model No.	ESCI	FSP30	3104C
Calibration Date	Oct. 16, 2014	Nov. 19, 2014	Jan. 22, 2015
Calibration Due Date	Oct. 16, 2015	Nov. 19, 2015	Jul. 22, 2016

Equipment	Log Periodic Antenna	Pyramidal Horn Antenna	Double Ridged Guide Antenna
Registration No.	EW-0447	EW-0905	EW-1133
Manufacturer	EMCO	EMCO	EMCO
Model No.	3146	3160-09	3115
Calibration Date	Mar. 16, 2015	Jun. 05, 2014	Apr. 30, 2014
Calibration Due Date	Sep. 16, 2016	Dec. 05, 2015	Oct. 30, 2015

2) Bandedge Measurement

Equipment	Spectrum Analyzer
Registration No.	EW-2249
Manufacturer	R&S
Model No.	FSP30
Calibration Date	Nov. 19, 2014
Calibration Due Date	Nov. 19, 2015

3) Conducted Emissions Test

Equipment	EMI Test Receiver	LISN
Registration No.	EW-2500	EW-2874
Manufacturer	R&S	R&S
Model No.	ESCI	ENV-216
Calibration Date	Nov. 06, 2014	Dec. 08, 2014
Calibration Due Date	Nov. 06, 2015	Dec. 08, 2015

END OF TEST REPORT