

# Item No.:I - 228P

## Wireless Motion Sensor Doorbell Instruction 32 Sounds Selectable

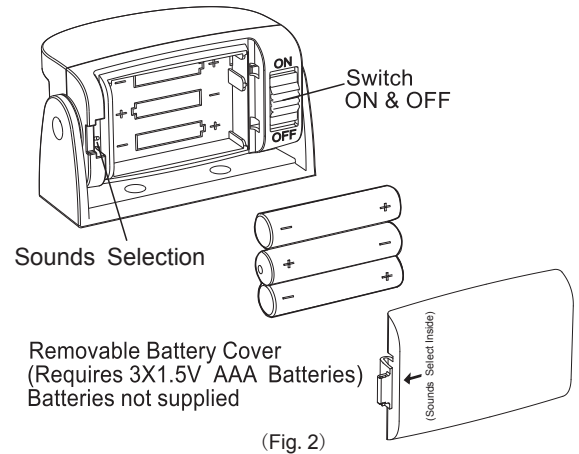

### Installation

The sensor can be mounted on wall or put on the table.  
The chime can be put on table or put to the strap.

### Select Sound

There are 32 sounds selectable for user. The desired tune can be selected by pressing the button inside the sensor.

### Power on the item

Plug in the receiver  
Sensor uses 3x1.5V AAA Batteries  
Receiver uses 120V main power.

### Receiver unit

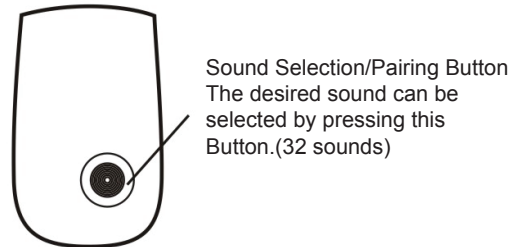

### Sensor Unit

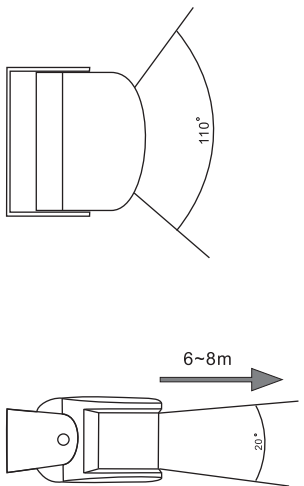

(Fig. 1)

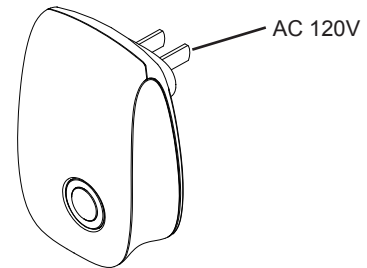

(Fig.3)

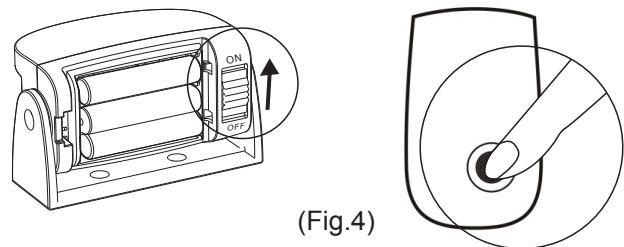

### Pairing Method

- Press the button one time in the receiver, to replay the current sound
- Hold the button for 5 seconds, the receiver will have "Ding-Ding" sounds. then turn on the sensor until the receiver has "Ding" means pairing between sensor and receiver is completed. It will have another "Ding-Ding" to exit pairing status.

This device complies with part 15 of the FCC Rules.

Operation is subject to the following two conditions: (1) This device may not cause harmful interference, and (2) this device must accept any interference received, including interference that may cause undesired operation.

Note: This equipment has been tested and found to comply with the limits for a Class B digital device, pursuant to Part 15 of the FCC Rules.

These limits are designed to provide reasonable protection against harmful interference in a residential installation. This equipment generates uses and can radiate radio frequency energy and, if not installed and used in accordance with the instructions, may cause harmful interference to radio communications.

However, there is no guarantee that interference will not occur in a particular installation. If this equipment does cause harmful interference to radio or television reception, which can be determined by turning the equipment off and on, the user is encouraged to try to correct the interference by one or more of the following measures:

Reorient or relocate the receiving antenna.

Increase the separation between the equipment and receiver.

Connect the equipment into an outlet on a circuit different from that to which the receiver is connected.

Consult the dealer or an experienced radio/TV technician for help.

Warning: Changes or modifications to this unit not expressly approved by the part responsible for compliance could void the user's authority to operate the equipment.