



731 Enterprise Drive
Lexington, KY 40510

Telephone: 859-226-1000
Facsimile: 859-226-1040
www.intertek-etlsemko.com

TEST REPORT

Report Number: 101078559LEX-015a
Project Number: G101078559

Report Issue Date: 7/25/2013

Product Name: iX101T1 Rugged Tablet
Model Number: iX101T1
FCCID: Q2GWWG7550A
ICID: 4596A-WG7550A

Standards: Title 47 CFR Part 15 Subpart C and RSS-210
Issue 8

Radios Under Test: Low Energy Bluetooth (BT4.0)

Tested by:
Intertek Testing Services NA, Inc.
731 Enterprise Drive
Lexington, KY 40510

Client:
Xplore Technologies
14000 Summit Dr.
Austin, TX 78728

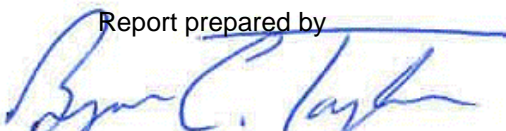
Report prepared by

Bryan Taylor, Team Leader

Report reviewed by

Jason Centers, Senior Project Engineer



This report is for the exclusive use of Intertek's Client and is provided pursuant to the agreement between Intertek and its Client. Intertek's responsibility and liability are limited to the terms and conditions of the agreement. Intertek assumes no liability to any party, other than to the Client in accordance with the agreement, for any loss, expense or damage occasioned by the use of this report. Only the Client is authorized to permit copying or distribution of this report and then only in its entirety. Any use of the Intertek name or one of its marks for the sale or advertisement of the tested material, product or service must first be approved in writing by Intertek. The observations and test results in this report are relevant only to the sample tested. This report by itself does not imply that the material, product, or service is or has ever been under an Intertek certification program.

TABLE OF CONTENTS

1 Introduction and Conclusion..... 3

2 Test Summary 3

3 Description of Equipment Under Test 4

4 Peak Conducted Power 6

5 Occupied Bandwidth 9

6 Conducted Spurious Emissions..... 12

7 Power Spectral Density..... 17

8 Radiated Spurious Emissions (Transmitter)..... 20

9 Radiated Spurious Emissions (Receiver)..... 24

10 AC Powerline Conducted Emissions 27

11 Antenna Requirement per FCC Part 15.203..... 30

12 Measurement Uncertainty..... 31

13 Revision History 32

1 Introduction and Conclusion

The tests indicated in section 2 were performed on the product constructed as described in section 3. The remaining test sections are the verbatim text from the actual data sheets used during the investigation. These test sections include the test name, the specified test method, a list of the actual test equipment used, documentation photos, results and raw data. No additions, deviations, or exclusions have been made from the standard(s) unless specifically noted.

Based on the results of our investigation, we have concluded the product tested complied with the requirements of the standard(s) indicated. The results obtained in this test report pertain only to the item(s) tested.

The INTERTEK-Lexington is located at 731 Enterprise Drive, Lexington Kentucky, 40510. The radiated emission test site is a 10-meter semi-anechoic chamber. The chamber meets the characteristics of CISPR 16-1 and ANSI C63.4. For measurements, a remotely controlled flush-mount metal-top turntable is used to rotate the EUT a full 360 degrees. A remote controlled non-conductive antenna mast is used to scan the antenna height from one to four meters. The test site is listed with the FCC under registration number 485103. The test site is listed with Industry Canada under site number IC 2042M-1.

2 Test Summary

Page	Test full name	FCC Reference	IC Reference	Result
6	Peak Conducted Power	§ 15.247(b)(3)(4)	RSS-210 (A8.4)	Pass
9	Occupied Bandwidth	§ 15.247(a)(2)	RSS-210 (A8.2), RSS-GEN (4.6.1)	Pass
12	Conducted Spurious Emissions	§ 15.247(d)	RSS-210 (A8.5)	Pass
17	Power Spectral Density	§ 15.247(e)	RSS-210 (A8.2b)	Pass
20	Radiated Spurious Emissions (Transmitter)	§ 15.247(d), § 15.209, and § 15.205	RSS-210 (2.2) (A8.5)	Pass
24	Radiated Spurious Emissions (Receiver)	§ 15.109	RSS-Gen (6.1)	Pass
27	AC Powerline Conducted Emissions	§ 15.107, § 15.207	RSS-Gen (7.2.4)	Pass
30	Antenna Requirement per FCC Part 15.203	§ 15.203	RSS-Gen (7.1.2)	Pass

3 Description of Equipment Under Test

Equipment Under Test	
Manufacturer	Xplore Technologies
Model Number	iX101T1
Serial Number	Test Sample #2
FCC Identifier	Q2GWWG7550A
IC Identifier	4596A-WG7550A
Receive Date	7/11/2013
Test Start Date	7/10/2013
Test End Date	7/11/2013
Device Received Condition	Good
Test Sample Type	Production
Frequency Band	2402MHz – 2480MHz
Mode(s) of Operation	BT4.0
Modulation Type	GFSK
Number of Hopping Channels	40
Transmission Control	Test Commands
Test Channels	0, 19, 39 (2402, 2440, 2480 MHz)
Antenna Type (15.203)	Internal
Power Supply	115VAC/60Hz (Via AC / DC Power Adapter)

Description of Equipment Under Test
The iX101T1 is a ruggedized tablet PC.

Operating modes of the EUT:

No.	Descriptions of EUT Exercising
1	Transmitting BT4.0 Signal on low mid or high channels
2	Receive / idle mode

3.1 System setup including cable interconnection details, support equipment and simplified block diagram

3.2 EUT Block Diagram:

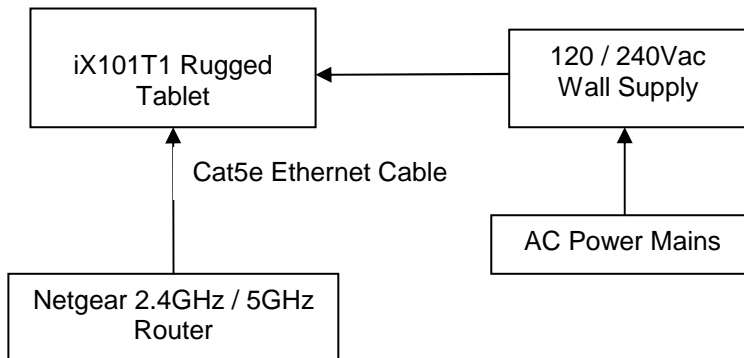

3.3 Cables:

Cables					
Description	Length	Shielding	Ferrites	Connection	
				From	To
120 / 240Vac Power Cable	1m	No	No	120 / 240Vac Wall Supply	Xplore Tablet
Cat5e Ethernet Cable	1m	No	No	Netgear Ethernet / Wi-Fi Router	Xplore Tablet
HDMI Mini Cable	1m	Yes	No	Xplore Tablet	Unterminated
HDMI Cable	1m	Yes	No	Xplore Tablet	Unterminated
Micro USB Cable	1m	Yes	No	Xplore Tablet	Unterminated
USB Cable	1m	Yes	No	USB Mouse	Xplore Tablet

3.4 Support Equipment:

Support Equipment			
Description	Manufacturer	Model Number	Serial Number
Wireless Router	Netgear	WNDR3700v4	311315801CC9

4 Peak Conducted Power

4.1 Test Limits

§ 15.247(b)(3): For systems using digital modulation in the 902–928 MHz, 2400–2483.5 MHz, and 5725–5850 MHz bands: 1 Watt. As an alternative to a peak power measurement, compliance with the one Watt limit can be based on a measurement of the maximum conducted output power. Maximum Conducted Output Power is defined as the total transmit power delivered to all antennas and antenna elements averaged across all symbols in the signaling alphabet when the transmitter is operating at its maximum power control level. Power must be summed across all antennas and antenna elements. The average must not include any time intervals during which the transmitter is off or is transmitting at a reduced power level. If multiple modes of operation are possible (e.g., alternative modulation methods), the *maximum conducted output power* is the highest total transmit power occurring in any mode.

§ 15.247(b)(4): The conducted output power limit specified in paragraph (b) of this section is based on the use of antennas with directional gains that do not exceed 6 dBi. Except as shown in paragraph (c) of this section, if transmitting antennas of directional gain greater than 6 dBi are used, the conducted output power from the intentional radiator shall be reduced below the stated values in paragraphs (b)(1), (b)(2), and (b)(3) of this section, as appropriate, by the amount in dB that the directional gain of the antenna exceeds 6 dBi.

4.2 Test Procedure

ANSI C63.10: 2009 and KDB Publication No. 558074: Guidance on Measurements for Digital Transmission Systems (47 CFR 15.247). The peak output power was measured using the channel power function of the spectrum analyzer.

4.3 Test Equipment Used:

Description	Serial Number	Manufacturer	Model	Cal. Date	Cal. Due
Spectrum Analyzer	3720	Rohde&Schwarz	FSEK30	11/26/2012	11/26/2013

4.4 Results:

The peak output power measurements were all below the 30dBm limit.

Mode	Channel Number	Frequency (MHz)	Peak Output Power (dBm)	Limit (dBm)	Result
BT4.0	0	2402	7.96	30	Pass
BT4.0	19	2440	8.08	30	Pass
BT4.0	39	2480	8.24	30	Pass

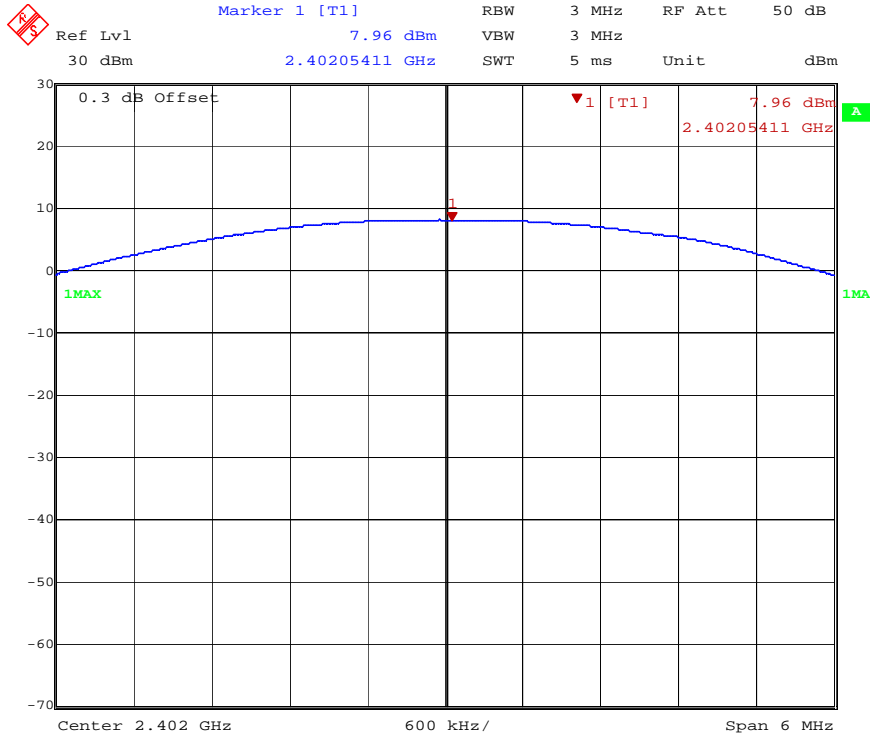

Date: 11.JUL.2013 12:01:06

Peak Output Power, Low Channel

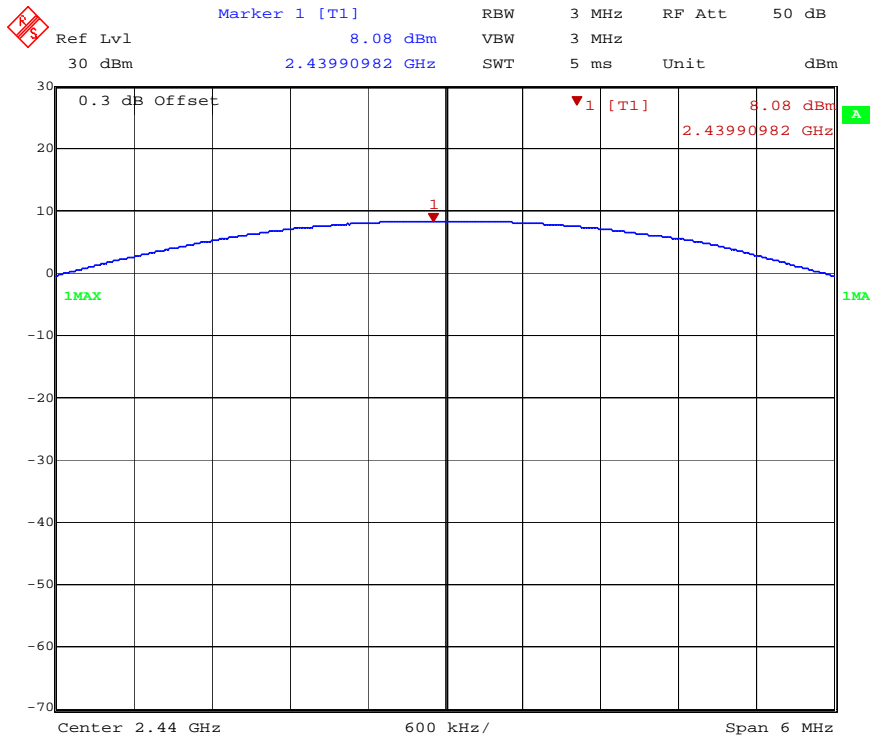

Date: 11.JUL.2013 12:02:50

Peak Output Power, Mid Channel



Marker 1 [T1] RBW 3 MHz RF Att 50 dB
Ref Lvl 8.24 dBm VBW 3 MHz
30 dBm 2.47995792 GHz SWT 5 ms Unit dBm

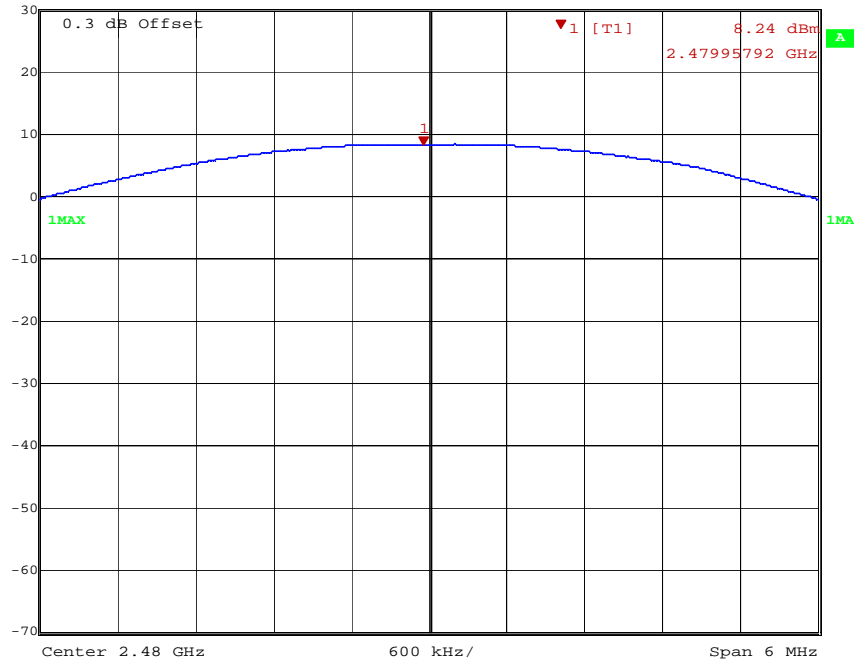

Date: 11.JUL.2013 12:04:34

Peak Output Power, High Channel

5 Occupied Bandwidth

5.1 Test Limits

§ 15.247(a)(2): For digital modulation systems, the minimum 6dB bandwidth shall be at least 500kHz.

5.2 Test Procedure

ANSI C63.10: 2009 and KDB Publication No. 558074: Guidance on Measurements for Digital Transmission Systems (47 CFR 15.247)

5.3 Test Equipment Used:

Description	Serial Number	Manufacturer	Model	Cal. Date	Cal. Due
Spectrum Analyzer	3720	Rohde&Schwarz	FSEK30	11/26/2012	11/26/2013

5.4 Results:

Mode	Channel Number	Frequency (MHz)	6dB Bandwidth	99% Power Bandwidth	Result
BT4.0	0	2402	513.0kHz	---	Pass
BT4.0	19	2440	517.0kHz	1.01MHz	Pass
BT4.0	39	2480	513.0kHz	---	Pass

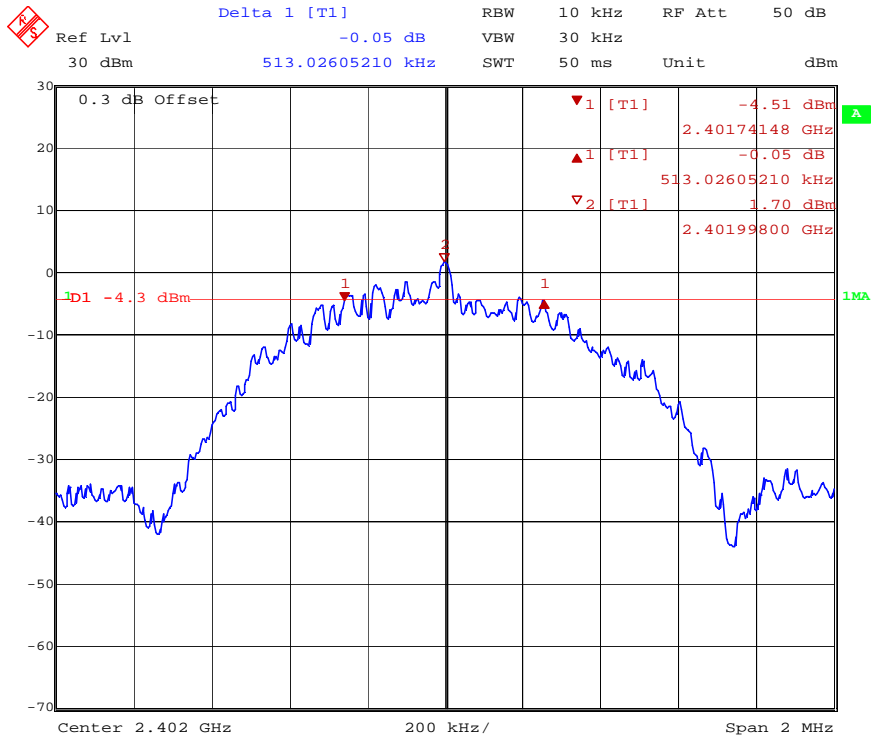

Date: 11.JUL.2013 12:20:25

6dB Bandwidth, Low Channel

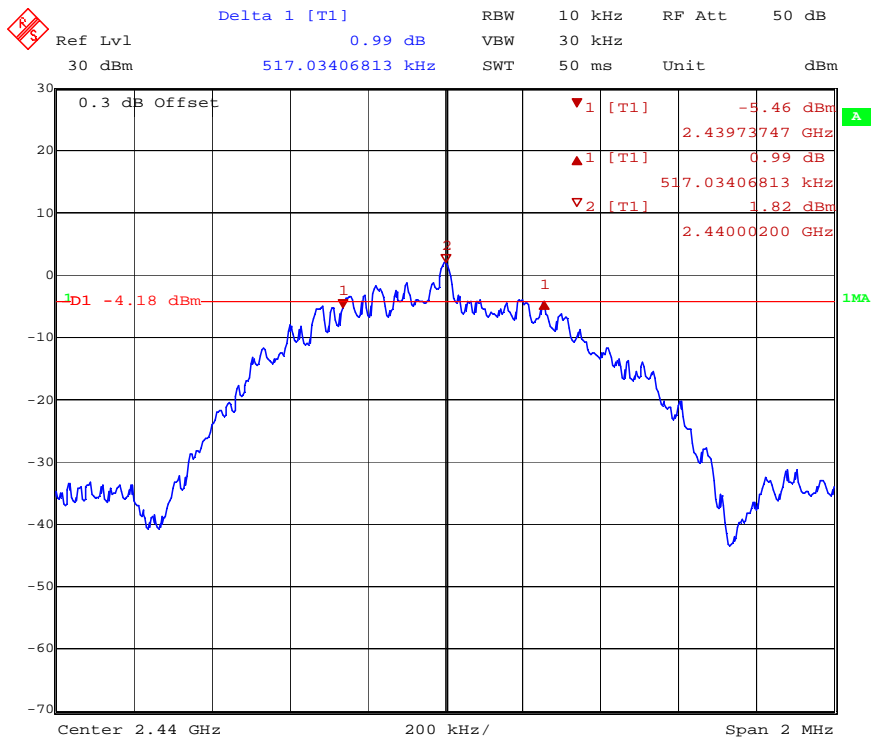

Date: 11.JUL.2013 12:15:21

6dB Bandwidth, Middle Channel

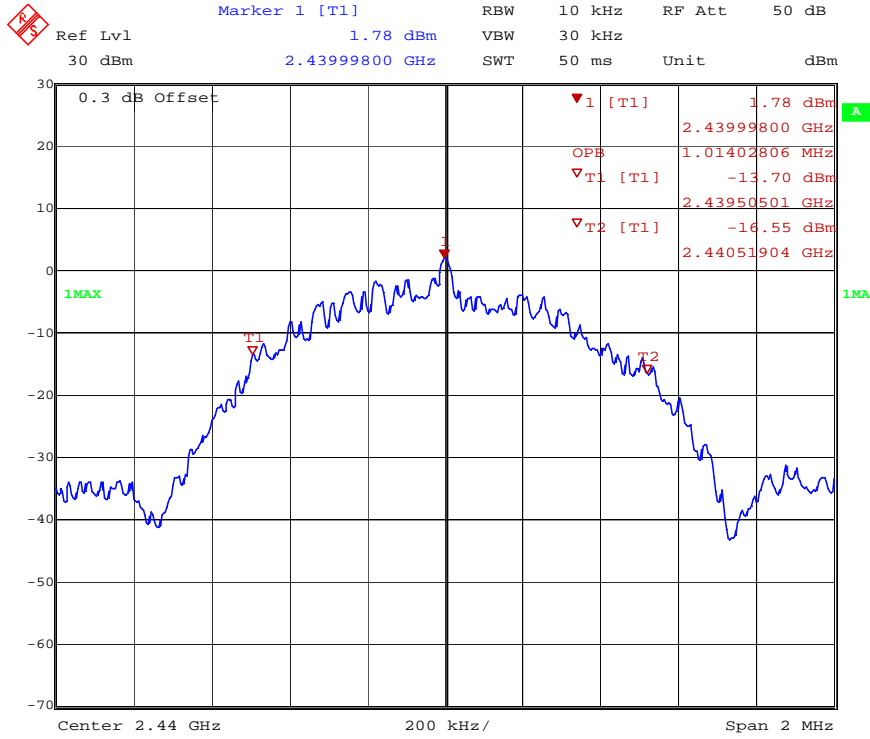

99% Bandwidth, Middle Channel

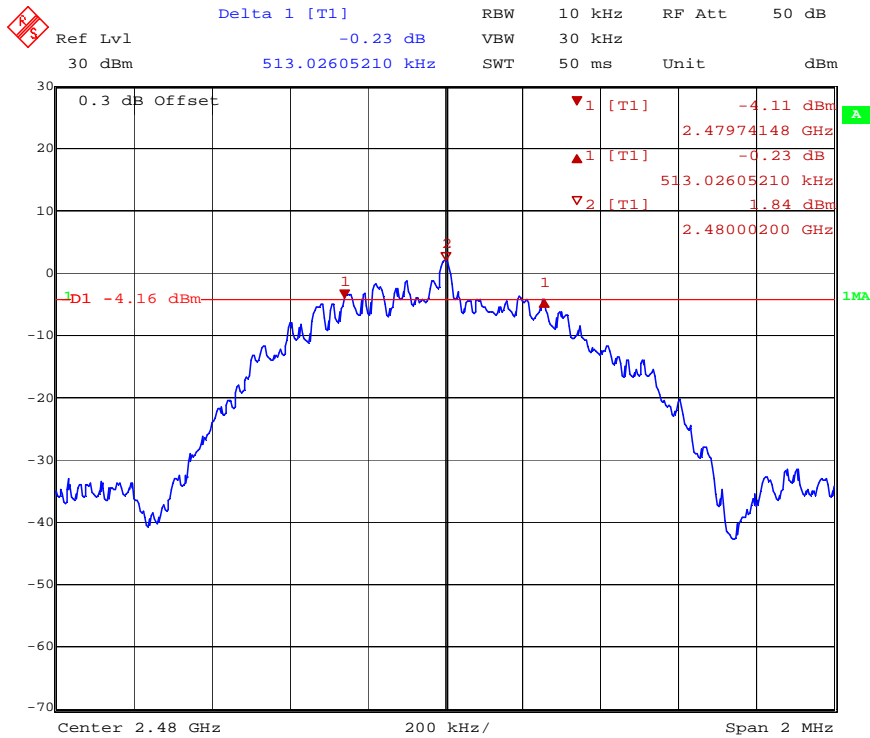

6dB Bandwidth, High Channel

6 Conducted Spurious Emissions

6.1 Test Limits

§ 15.247(d): In any 100 kHz bandwidth outside the frequency band in which the spread spectrum or digitally modulated intentional radiator is operating, the radio frequency power that is produced by the intentional radiator shall be at least 20 dB below that in the 100 kHz bandwidth within the band that contains the highest level of the desired power, based on either an RF conducted or a radiated measurement, provided the transmitter demonstrates compliance with the peak conducted power limits. If the transmitter complies with the conducted power limits based on the use of RMS averaging over a time interval, as permitted under paragraph (b)(3) of this section, the attenuation required under this paragraph shall be 30 dB instead of 20 dB.

6.2 Test Procedure

ANSI C63.10: 2009 and KDB Publication No. 558074: Guidance on Measurements for Digital Transmission Systems (47 CFR 15.247)

6.3 Test Equipment Used:

Description	Serial Number	Manufacturer	Model	Cal. Date	Cal. Due
Spectrum Analyzer	3720	Rohde&Schwarz	FSEK30	11/26/2012	11/26/2013

6.4 Results:

The following plots show that there are no conducted spurious emissions exceeding the 20dB down criteria.

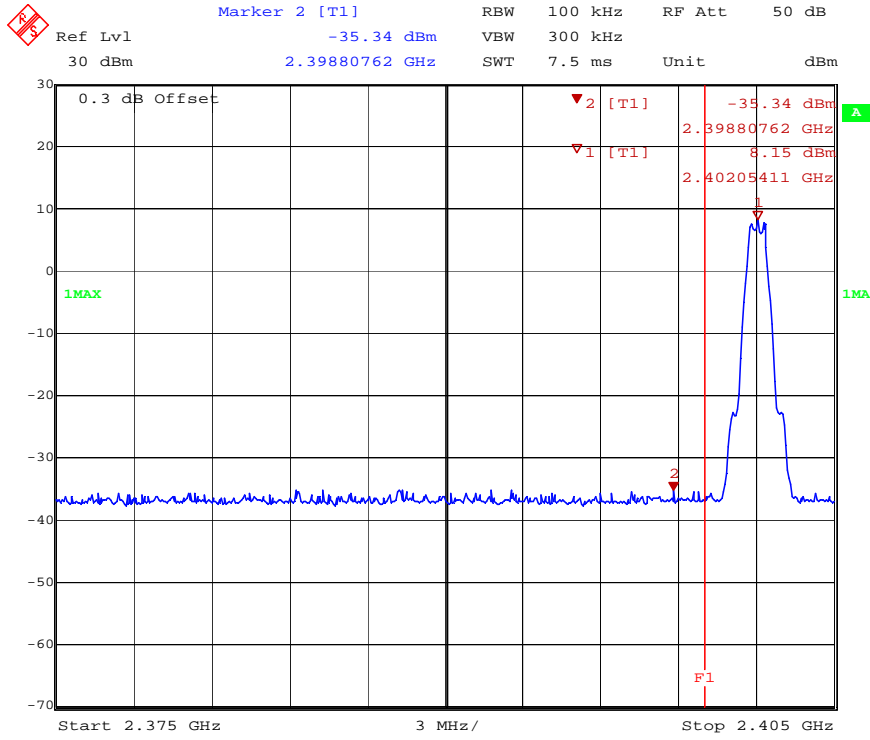

Low Band Edge Plot, Low Channel

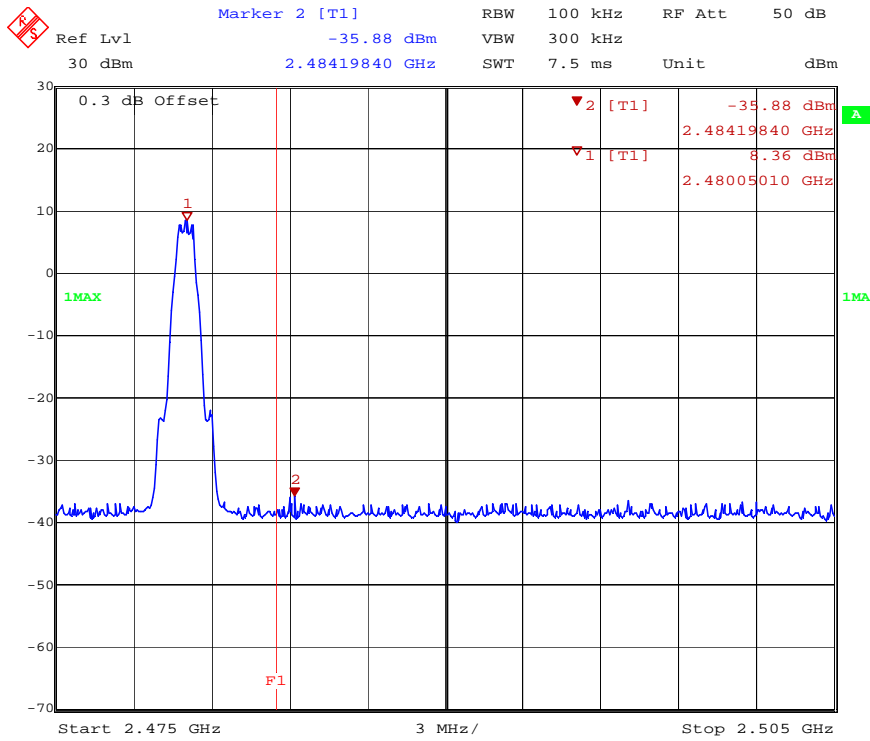

High Band Edge Plot, High Channel

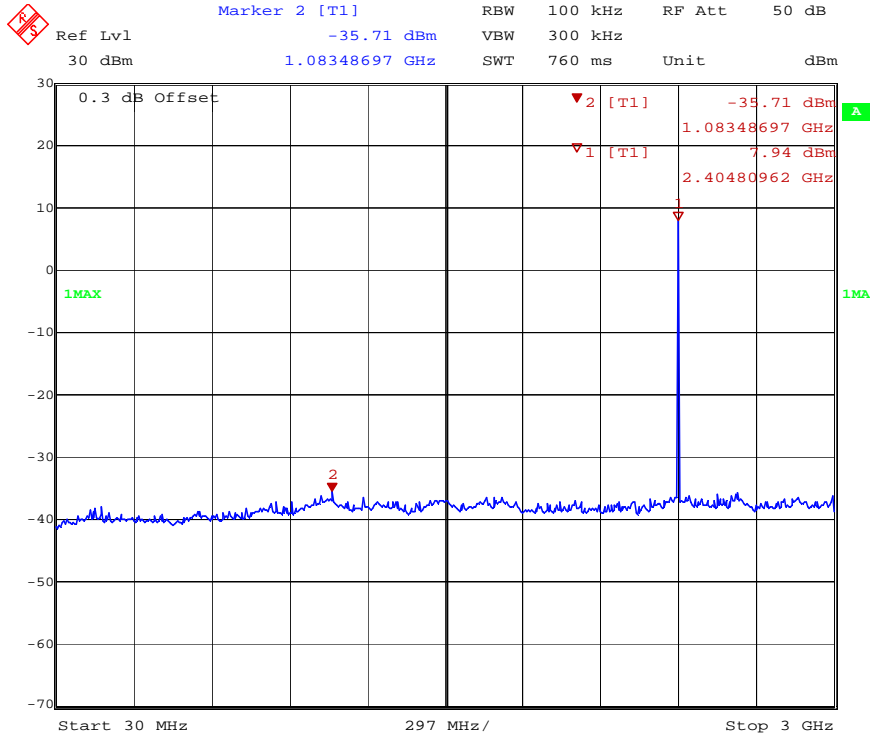

Date: 11.JUL.2013 13:17:57

Conducted Spurious Emissions, Low Channel

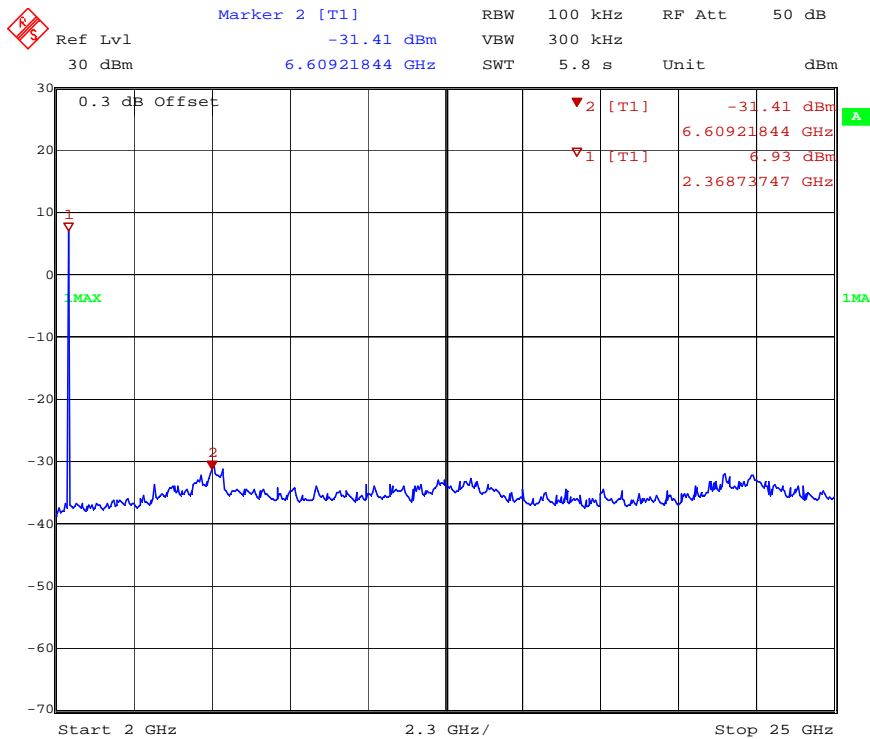

Date: 11.JUL.2013 13:19:10

Conducted Spurious Emissions, Low Channel

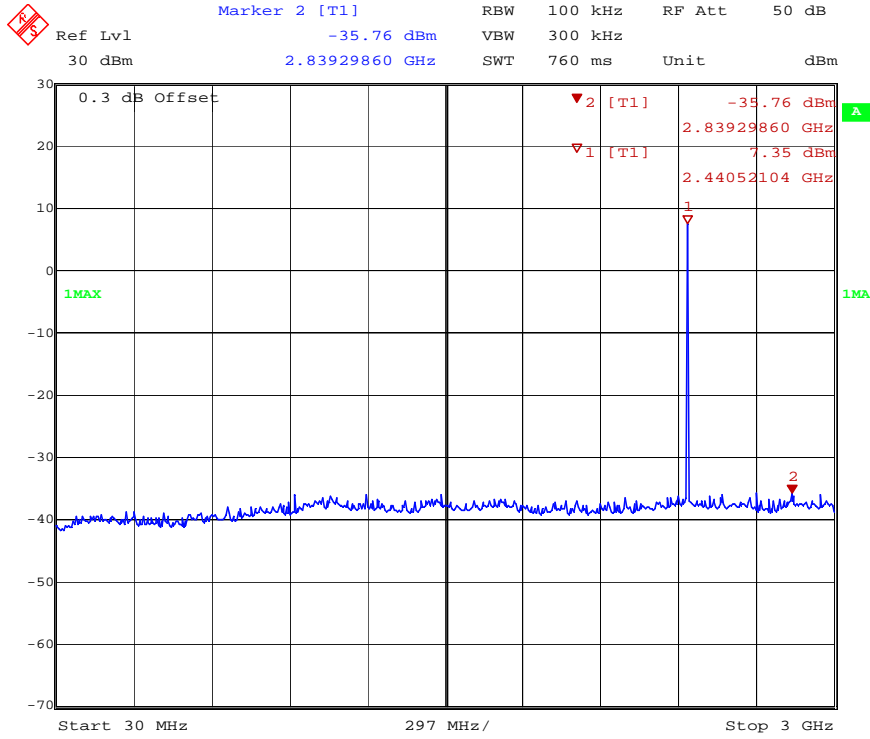

Date: 11.JUL.2013 13:14:32

Conducted Spurious Emissions, Middle Channel

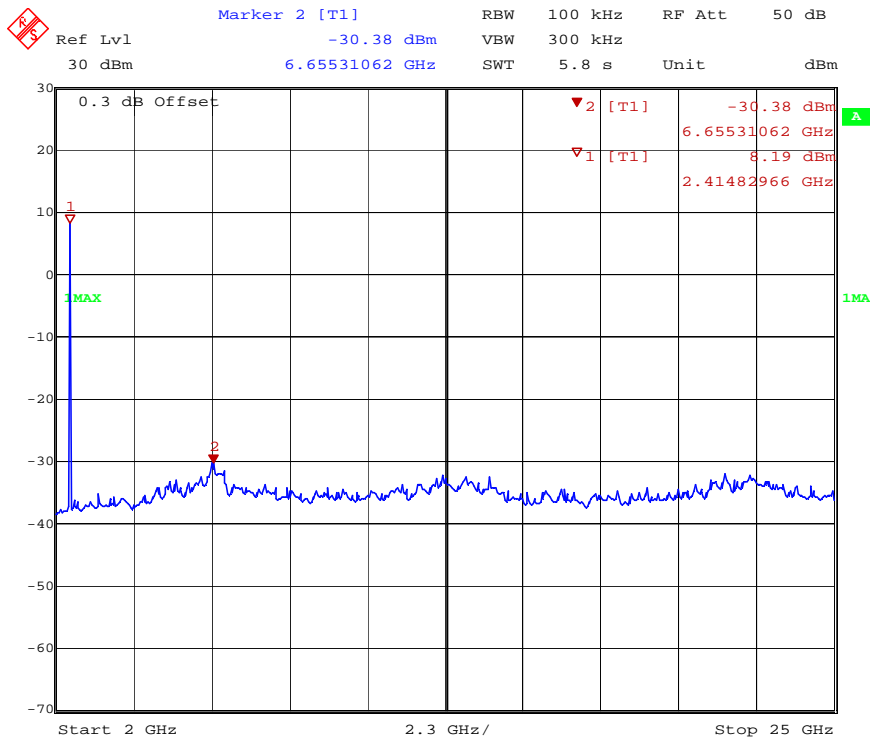

Date: 11.JUL.2013 13:16:25

Conducted Spurious Emissions, Middle Channel

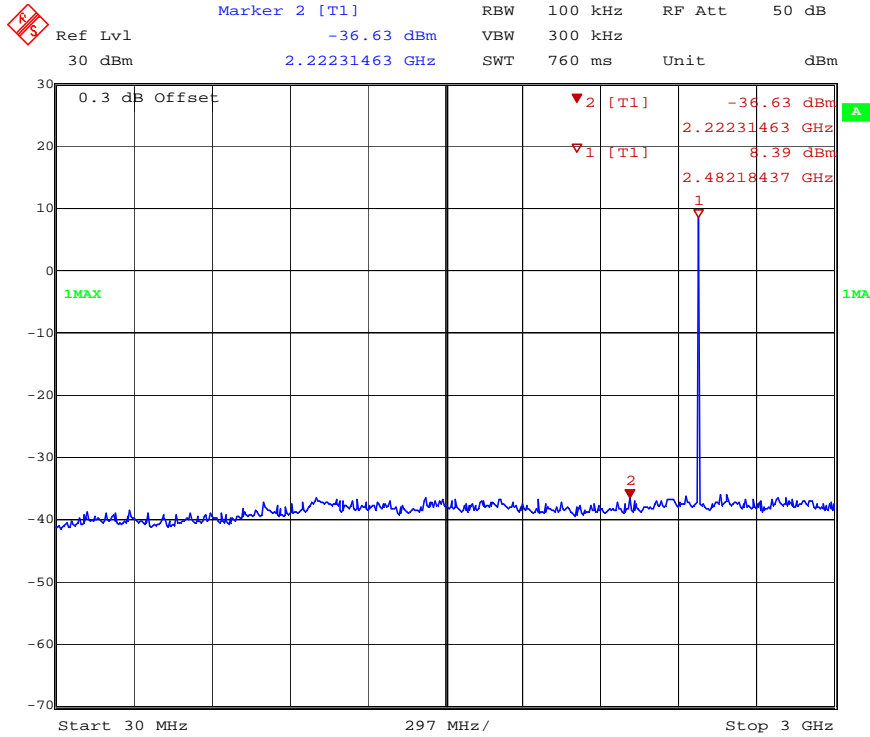

Date: 11.JUL.2013 13:10:17

Conducted Spurious Emissions, High Channel

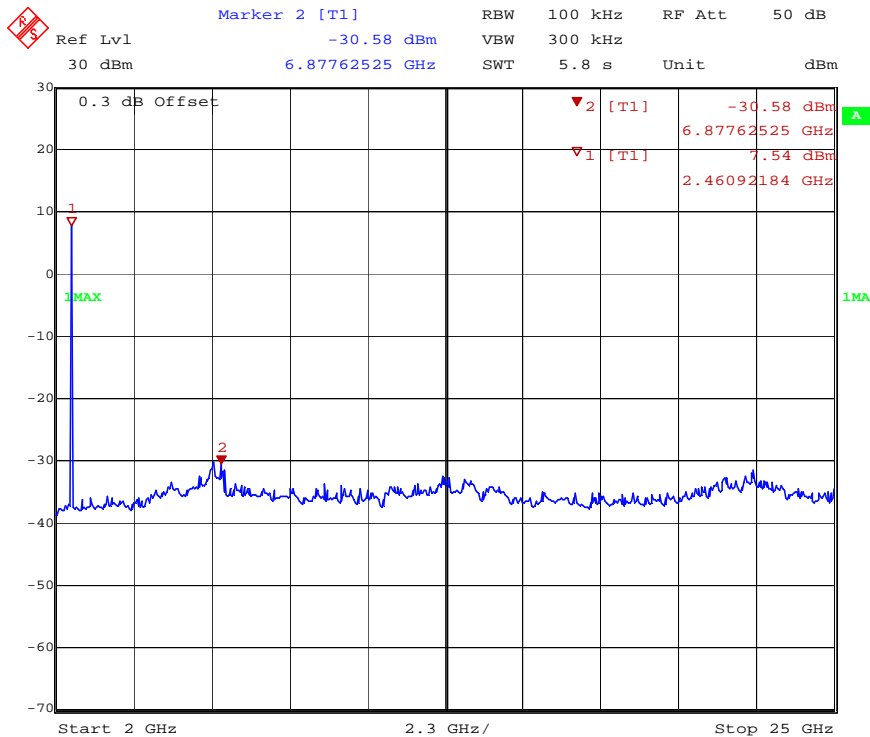

Date: 11.JUL.2013 13:12:31

Conducted Spurious Emissions, High Channel

7 Power Spectral Density

7.1 Test Limits

§ 15.247(e): For digitally modulated systems, the power spectral density conducted from the intentional radiator to the antenna shall not be greater than 8 dBm in any 3 kHz band during any time interval of continuous transmission. This power spectral density shall be determined in accordance with the provisions of paragraph (b) of this section. The same method of determining the conducted output power shall be used to determine the power spectral density.

7.2 Test Procedure

ANSI C63.10: 2009 and KDB Publication No. 558074: Guidance on Measurements for Digital Transmission Systems (47 CFR 15.247)

7.3 Test Equipment Used:

Description	Serial Number	Manufacturer	Model	Cal. Date	Cal. Due
Spectrum Analyzer	3720	Rohde&Schwarz	FSEK30	11/26/2012	11/26/2013

7.4 Results:

*PSD Option 1 Method

Mode	Channel Number	Frequency (MHz)	PSD in 3kHz BW (dBm)	Limit (dBm)	Result
BT4.0	0	2402	-6.87	8.0	Pass
BT4.0	19	2440	-6.76	8.0	Pass
BT4.0	39	2480	-6.53	8.0	Pass

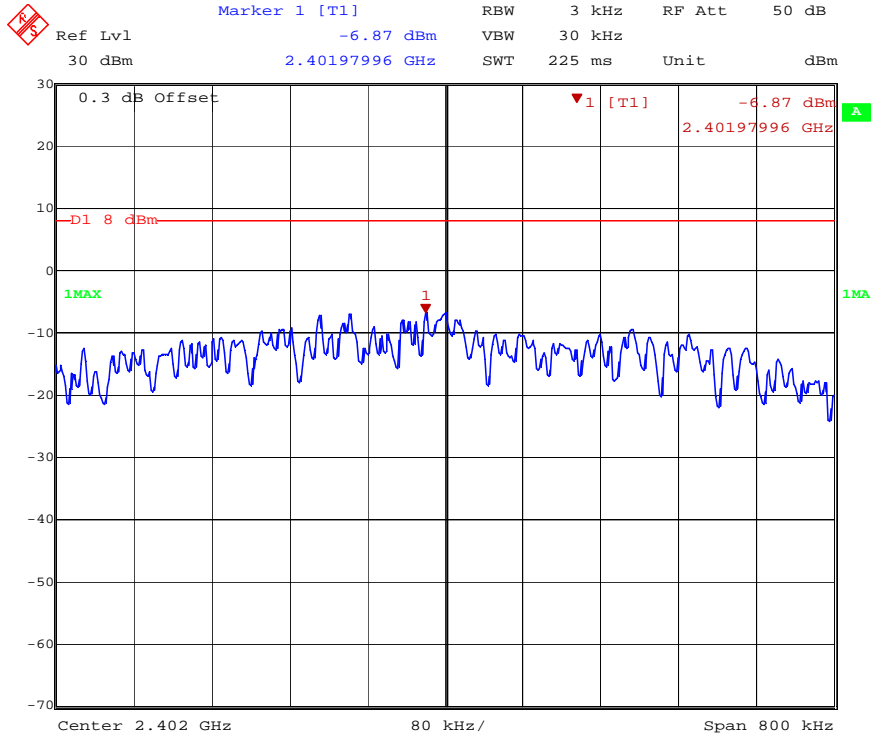

PSD Low Channel

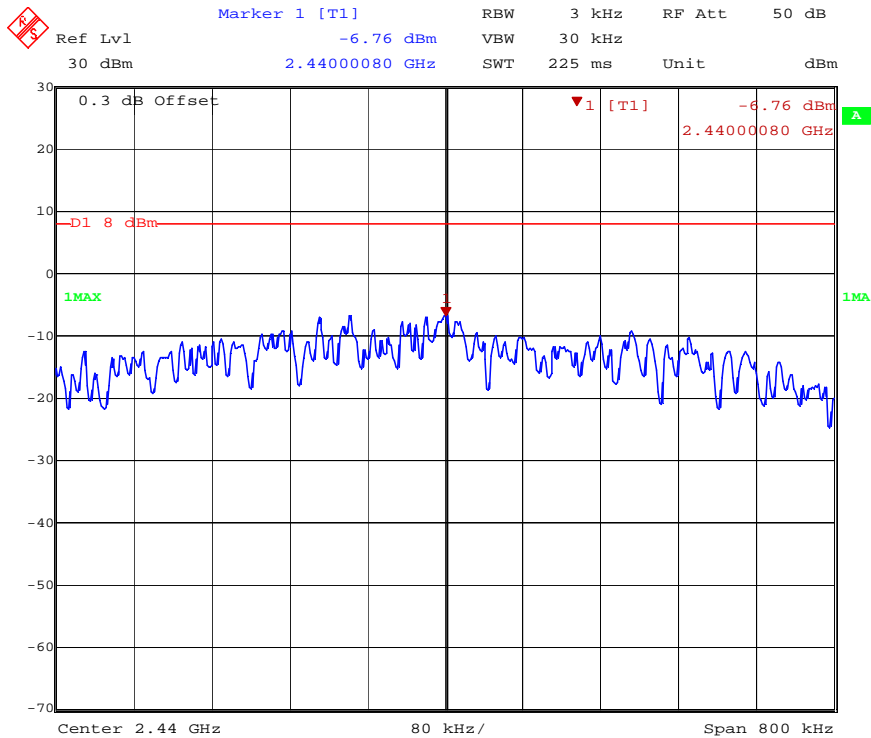

PSD Middle Channel

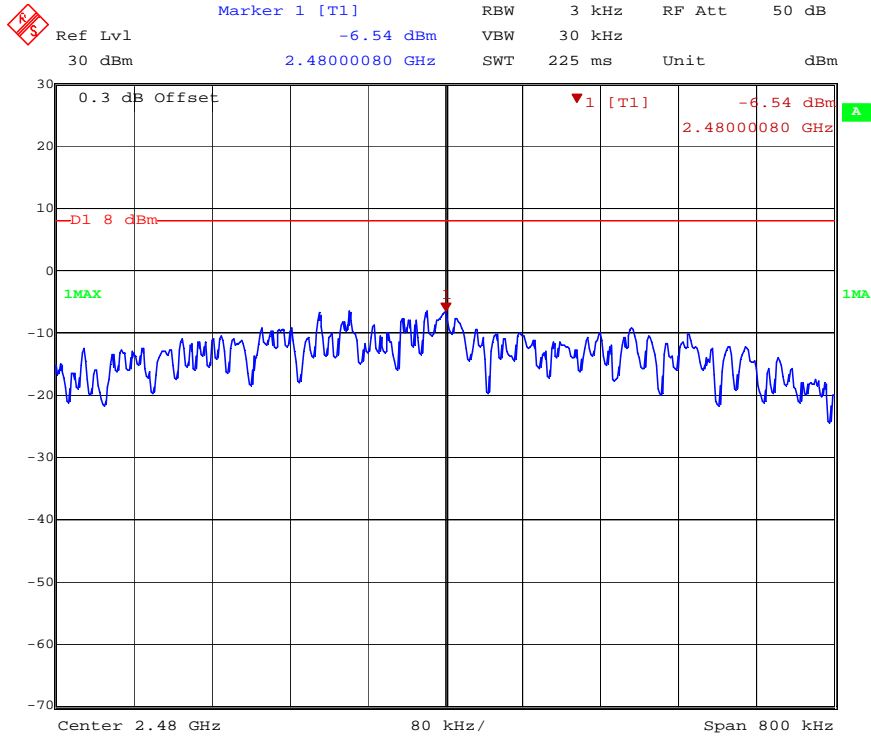

Date: 11.JUL.2013 12:55:24

PSD, High Channel

8 Radiated Spurious Emissions (Transmitter)

8.1 Test Limits

§ 15.247(d): In any 100 kHz bandwidth outside the frequency band in which the spread spectrum or digitally modulated intentional radiator is operating, the radio frequency power that is produced by the intentional radiator shall be at least 20 dB below that in the 100 kHz bandwidth within the band that contains the highest level of the desired power, based on either an RF conducted or a radiated measurement, provided the transmitter demonstrates compliance with the peak conducted power limits. If the transmitter complies with the conducted power limits based on the use of RMS averaging over a time interval, as permitted under paragraph (b)(3) of this section, the attenuation required under this paragraph shall be 30 dB instead of 20 dB. Attenuation below the general limits specified in §15.209(a) is not required. In addition, radiated emissions which fall in the restricted bands, as defined in §15.205(a), must also comply with the radiated emission limits specified in §15.209(a) (see §15.205(c)).

Part 15.205(a): Restricted Bands of Operations

MHz	MHz	MHz	GHz
0.090–0.110	16.42–16.423	399.9–410	4.5–5.15
10.495–0.505	16.69475–16.69525	608–614	5.35–5.46
2.1735–2.1905	16.80425–16.80475	960–1240	7.25–7.75
4.125–4.128	25.5–25.67	1300–1427	8.025–8.5
4.17725–4.17775	37.5–38.25	1435–1626.5	9.0–9.2
4.20725–4.20775	73–74.6	1645.5–1646.5	9.3–9.5
6.215–6.218	74.8–75.2	1660–1710	10.6–12.7
6.26775–6.26825	108–121.94	1718.8–1722.2	13.25–13.4
6.31175–6.31225	123–138	2200–2300	14.47–14.5
8.291–8.294	149.9–150.05	2310–2390	15.35–16.2
8.362–8.366	156.52475–156.52525	2483.5–2500	17.7–21.4
8.37625–8.38675	156.7–156.9	2655–2900	22.01–23.12
8.41425–8.41475	162.0125–167.17	3260–3267	23.6–24.0
12.29–12.293	167.72–173.2	3332–3339	31.2–31.8
12.51975–12.52025	240–285	3345.8–3358	36.43–36.5
12.57675–12.57725	322–335.4	3600–4400	(²)
13.36–13.41			

¹ Until February 1, 1999, this restricted band shall be 0.490–0.510 MHz.

² Above 38.6

Part 15.209(a): Field Strength Limits for Restricted Bands of Operation

Frequency (MHz)	Field Strength (microvolts/meter)	Measurement Distance (meters)
0.009 - 0.490	2,400 / F (kHz)	300
0.490 - 1.705	24,000 / F (kHz)	30
1.705 - 30.0	30	30
30 - 88	100	3
88 - 216	150	3
216 - 960	200	3
Above 960	500	3

8.2 Test Procedure

ANSI C63.10: 2009 and KDB Publication No. 558074: Guidance on Measurements for Digital Transmission Systems (47 CFR 15.247)

8.3 Example of Field Strength Calculation Method:

The measured field strength was calculated by summing the readings taken from the spectrum analyzer with the appropriate correction factors associated with the antenna losses and cable losses. The calculation formula and sample calculations are listed below:

Formula:

$$FS = RA + AF + CF$$

FS = Field Strength in dB μ V/m

RA = Receiver Amplitude in dB μ V

AF = Antenna Factor in dB

CF = Cable Attenuation Factor in dB (Including preamplifier and filter attenuation)

Example Calculation:

$$RA = 19.48 \text{ dB}\mu\text{V}$$

$$AF = 18.52 \text{ dB}$$

$$CF = 0.78 \text{ dB}$$

$$FS = 19.48 + 18.52 + 0.78 = 38.78 \text{ dB}\mu\text{V/m}$$

$$\text{Level in } \mu\text{V/m} = \text{Common Antilogarithm} [(38.78 \text{ dB}\mu\text{V/m})/20] = 86.89 \mu\text{V/m}$$

8.4 Test Equipment Used:

Description	Serial Number	Manufacturer	Model	Cal. Date	Cal. Due
EMI Test Receiver	10887490.26	Rohde & Schwarz	ESI26	9/15/2012	9/14/2013
Spectrum Analyzer	3720	Rohde & Schwarz	FSEK30	11/26/2012	11/26/2013
Preamplifier	987410	Miteq	AFS44-00102000-30-10P-44	9/4/2012	9/4/2013
Preamplifier	SF456200904	Mini-Circuits	ZX60-3018G-S+	9/4/2012	9/4/2013
Biconnilog Antenna	00051864	ETS	3142C	12/14/2012	12/14/2013
Horn Antenna	6556	ETS	3115	9/13/2012	9/13/2013
System Controller	121701-1	Sunol Sciences	SC99V	Calibration Not Required	Calibration Not Required
High Pass Filter	3986-01 DC0408	Microwave Circuits, Inc.	H3G020G2	Calibrate at Time Of Use	Calibrate at Time Of Use

8.5 Results:

All spurious emissions were attenuated by at least 20dB below the level of the fundamental as required by Part 15.247(d). Additionally, all emissions falling within restricted bands of operation and at the band edges were found to be below the limit specified in Part 15.209(a). The spurious emissions listed in the following tables are the worst case emissions. Emissions not reported were at or below the measurement noise floor. The test sample was evaluated on three orthogonal axes since it was a hand held device and could be used in any orientation.

TX Channel	Spurious Frequency	Polarity	Corr. Peak Reading. (dBuV/m)	Corr. Avg Reading. (dBuV/m)	Peak Limit (dBuV/m)	Avg. Limit (dBuV/m)	Results	Comments
Low Channel (2402MHz)	3.2529 GHz	V	35.703	24.703	74	54	Compliant	BLE (BT4.0)
	4.8034 GHz	V	50.943	39.103	74	54	Compliant	BLE (BT4.0)
	7.2061 GHz	V	41.349	34.559	74	54	Compliant	BLE (BT4.0)
	9.608 GHz	V	47.892	34.432	74	54	Compliant	BLE (BT4.0)
	12.01 GHz	V	44.691	35.391	74	54	Compliant	BLE (BT4.0)
	14.412 GHz	V	48.644	38.394	74	54	Compliant	BLE (BT4.0)
	3.2529 GHz	H	33.943	24.613	74	54	Compliant	BLE (BT4.0)
	4.8036 GHz	H	47.083	37.133	74	54	Compliant	BLE (BT4.0)
	7.206 GHz	H	47.668	34.618	74	54	Compliant	BLE (BT4.0)
	9.6091 GHz	H	48.716	36.336	74	54	Compliant	BLE (BT4.0)
	12.009 GHz	H	50.065	36.535	74	54	Compliant	BLE (BT4.0)
14.412 GHz	H	52.834	38.244	74	54	Compliant	BLE (BT4.0)	

Worst Case Spurious Emissions (BT4.0, Low Channel)

TX Channel	Spurious Frequency	Polarity	Corr. Peak Reading. (dBuV/m)	Corr. Avg Reading. (dBuV/m)	Peak Limit (dBuV/m)	Avg. Limit (dBuV/m)	Results	Comments
Middle Channel (2440MHz)	3.253 GHz	V	48.993	38.143	74	54	Compliant	BLE (BT4.0)
	4.8795 GHz	V	57.971	47.601	74	54	Compliant	BLE (BT4.0)
	7.32 GHz	V	44.295	38.535	74	54	Compliant	BLE (BT4.0)
	9.759 GHz	V	49.494	39.534	74	54	Compliant	BLE (BT4.0)
	12.199 GHz	V	42.042	38.462	74	54	Compliant	BLE (BT4.0)
	14.64 GHz	V	48.126	38.746	74	54	Compliant	BLE (BT4.0)
	3.2532 GHz	H	49.535	42.895	74	54	Compliant	BLE (BT4.0)
	4.8795 GHz	H	53.681	44.191	74	54	Compliant	BLE (BT4.0)
	7.32 GHz	H	41.975	34.465	74	54	Compliant	BLE (BT4.0)
	9.76 GHz	H	48.826	34.886	74	54	Compliant	BLE (BT4.0)
	12.199 GHz	H	48.702	38.092	74	54	Compliant	BLE (BT4.0)
14.64 GHz	H	48.256	38.376	74	54	Compliant	BLE (BT4.0)	

Worst Case Spurious Emissions (BT4.0, Middle Channel)

TX Channel	Spurious Frequency	Polarity	Corr. Peak Reading. (dBuV/m)	Corr. Avg Reading. (dBuV/m)	Peak Limit (dBuV/m)	Avg. Limit (dBuV/m)	Results	Comments
High Channel (2480MHz)	3.2531 GHz	V	35.704	24.964	74	54	Compliant	BLE (BT4.0)
	4.9601 GHz	V	40.651	51.311	74	54	Compliant	BLE (BT4.0)
	7.4401 GHz	V	48.491	37.961	74	54	Compliant	BLE (BT4.0)
	9.92 GHz	V	45.142	36.202	74	54	Compliant	BLE (BT4.0)
	12.401 GHz	V	48.05	36.01	74	54	Compliant	BLE (BT4.0)
	14.879 GHz	V	51.524	39.424	74	54	Compliant	BLE (BT4.0)
	3.253 GHz	H	34.683	24.753	74	54	Compliant	BLE (BT4.0)
	4.96 GHz	H	53.021	48.901	74	54	Compliant	BLE (BT4.0)
	7.4409 GHz	H	47.482	36.262	74	54	Compliant	BLE (BT4.0)
	9.919 GHz	H	48.39	38.98	74	54	Compliant	BLE (BT4.0)
	12.4 GHz	H	44.743	35.203	74	54	Compliant	BLE (BT4.0)
14.88 GHz	H	47.013	38.033	74	54	Compliant	BLE (BT4.0)	

Worst Case Spurious Emissions (BT4.0, High Channel)

9 Radiated Spurious Emissions (Receiver)

9.1 Test Limits

§ 15.109: Except for Class A digital devices, the field strength of radiated emissions from unintentional radiators at a distance of 3 meters shall not exceed the following values:

Frequency of emission (MHz)	Field strength (microvolts/meter)	Field strength (dBuV/m)
30–88	100	40
88–216	150	43.5
216–960	200	46
Above 960	500	54

These limits are identical to those in RSS-GEN

9.2 Test Procedure

ANSI C63.4: 2009

9.3 Example of Field Strength Calculation Method:

The measured field strength was calculated by summing the readings taken from the spectrum analyzer with the appropriate correction factors associated with the antenna losses and cable losses. The calculation formula and sample calculations are listed below:

Formula:

$$FS = RA + AF + CF$$

FS = Field Strength in dB μ V/m

RA = Receiver Amplitude in dB μ V

AF = Antenna Factor in dB

CF = Cable Attenuation Factor in dB (Including preamplifier and filter attenuation)

Example Calculation:

$$RA = 19.48 \text{ dB}\mu\text{V}$$

$$AF = 18.52 \text{ dB}$$

$$CF = 0.78 \text{ dB}$$

$$FS = 19.48 + 18.52 + 0.78 = 38.78 \text{ dB}\mu\text{V/m}$$

$$\text{Level in } \mu\text{V/m} = \text{Common Antilogarithm} [(38.78 \text{ dB}\mu\text{V/m})/20] = 86.89 \mu\text{V/m}$$

9.4 Test Equipment Used:

Description	Serial Number	Manufacturer	Model	Cal. Date	Cal. Due
EMI Test Receiver	10887490.26	Rohde & Schwarz	ESI26	9/15/2012	9/14/2013
Preamplifier	SF456200904	Mini-Circuits	ZX60-3018G-S+	9/4/2012	9/4/2013
Biconnilog Antenna	00051864	ETS	3142C	12/14/2012	12/14/2013
Horn Antenna	6556	ETS	3115	9/13/2012	9/13/2013
System Controller	121701-1	Sunol Sciences	SC99V	Time of Use	Time of Use

9.5 Results:

All spurious emissions with the test sample in receive mode were below the limits specified in Part 15.109 for a class B digital device and RSS-GEN Section 6.1.

9.6 Test Data:

Radiated Emissions										
Test Engineer: Bryan Taylor		Start Date: 3/21/2013		End Date: 3/21/2013						
Temperature: 23.4C		Humidity: 38.20%		Pressure: 987.8mBar						
Specification: FCC Part 15 / EN55022		Test Limit: Class B								
Notes: Idle Mode										
A	B	C	D	E	F	G	H	I	J	K
Frequency	Polarity (H/V)	Raw Reading (dBuV)	Cab. (dB)	Ant. (dB)	Corr. Reading. (dBuV/m)	Limit (dBuV/m)	Delta (dB)	RBW / Detector	Test Distance	Results
30.0 MHz	V	19.08	-13.77	17.3	22.61	30	-7.39	120kHz / QP	10m	Compliant
459.8 MHz	V	26.49	-11.4	16.62	31.71	37	-5.29	120kHz / QP	10m	Compliant
467.9 MHz	V	25.71	-11.36	17.43	31.78	37	-5.22	120kHz / QP	10m	Compliant
492.1 MHz	V	22.3	-11.26	18.44	29.48	37	-7.52	120kHz / QP	10m	Compliant
537.6 MHz	V	25.96	-10.95	18.69	33.7	37	-3.3	120kHz / QP	10m	Compliant
30.0 MHz	H	18.98	-13.77	17.3	22.51	30	-7.49	120kHz / QP	10m	Compliant
458.7 MHz	H	27.01	-11.42	16.73	32.32	37	-4.68	120kHz / QP	10m	Compliant
494.47 MHz	H	25.48	-11.25	18.49	32.72	37	-4.28	120kHz / QP	10m	Compliant
Calculations:				F = C + D + E			H = F - G			

Deviations, Additions, or Exclusions: None

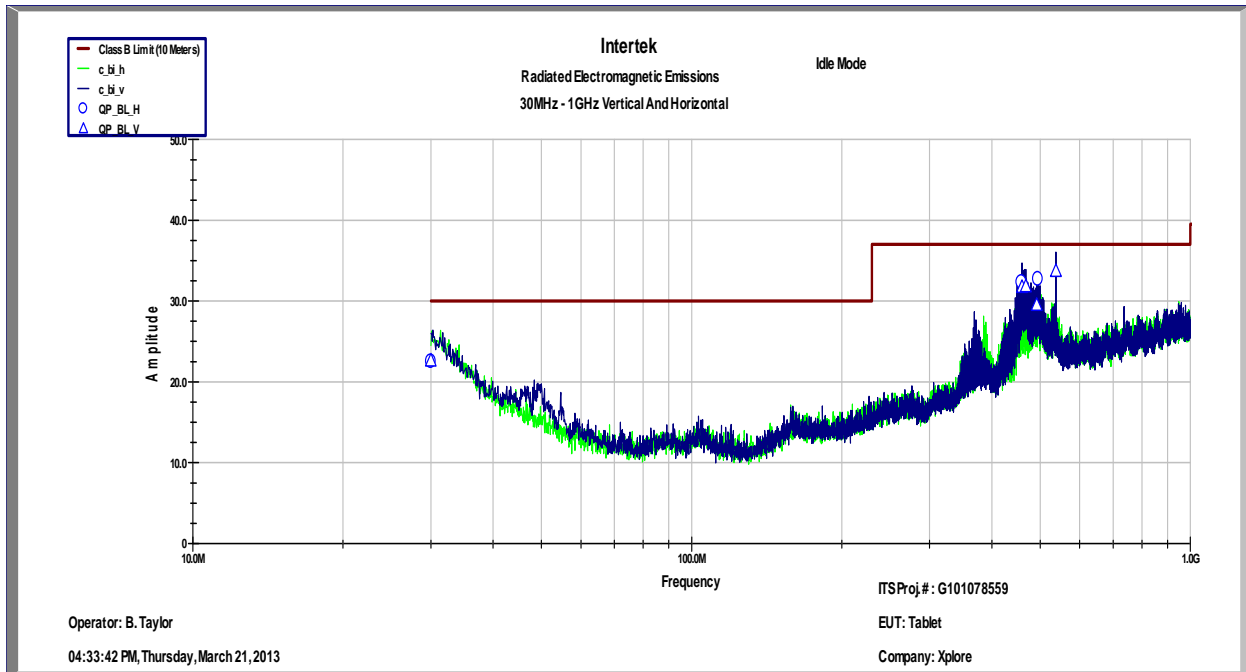

Bilog Prescan

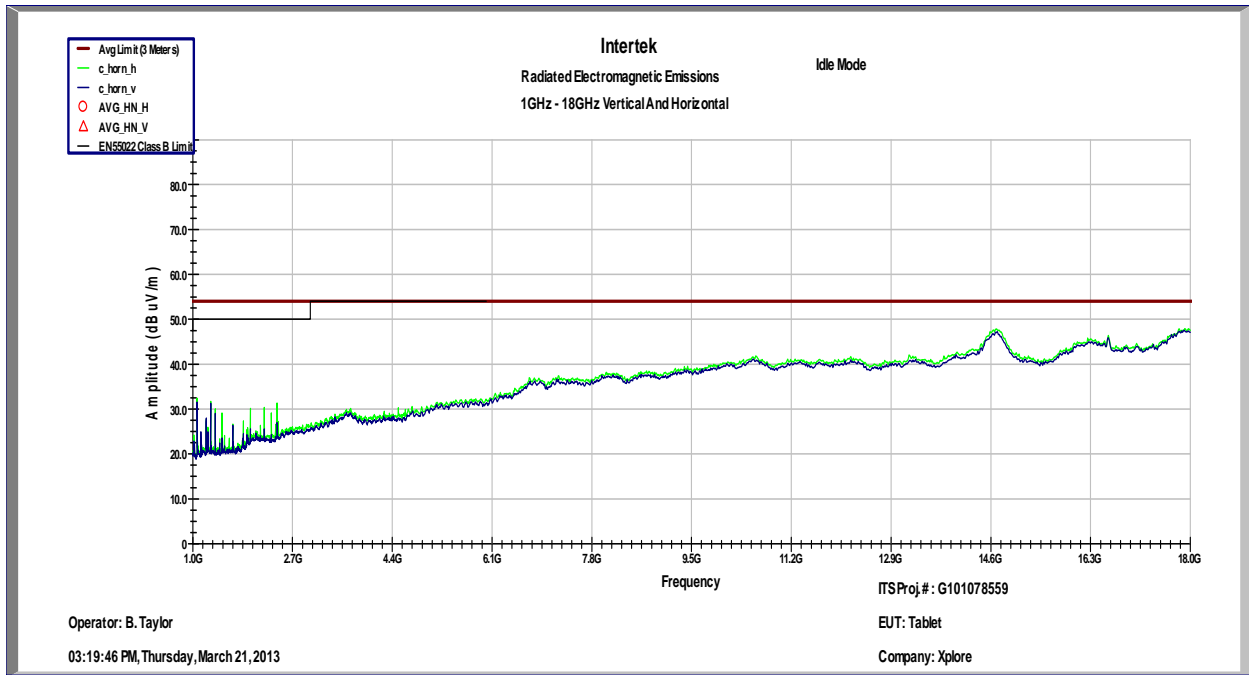

Horn Prescan

10 AC Powerline Conducted Emissions

10.1 Test Limits

§ 15.107(e): Except as shown in paragraphs (b) and (c) of this section, for an intentional radiator that is designed to be connected to the public utility (AC) power line, the radio frequency voltage that is conducted back onto the AC power line on any frequency or frequencies, within the band 150 kHz to 30 MHz, shall not exceed the limits in the following table, as measured using a 50 μ H/50 ohms line impedance stabilization network (LISN). Compliance with the provisions of this paragraph shall be based on the measurement of the radio frequency voltage between each power line and ground at the power terminal. The lower limit applies at the boundary between the frequency ranges.

Frequency of emission (MHz)	Conducted limit (dB μ V)	
	Quasi-peak	Average
0.15–0.5	66 to 56*	56 to 46*
0.5–5	56	46
5–30	60	50

*Decreases with the logarithm of the frequency.

10.2 Test Procedure

ANSI C63.4: 2003

10.3 Test Equipment Used:

Description	Serial Number	Manufacturer	Model	Cal. Date	Cal. Due
EMI Test Receiver	10887490.26	Rohde & Schwarz	ESi26	9/15/2012	9/14/2013
LISN	3333	Teseq	NNB52	3/11/2013	3/11/2014

10.4 Results:

The sample tested was found to Comply.

10.5 Data (Transmitting):

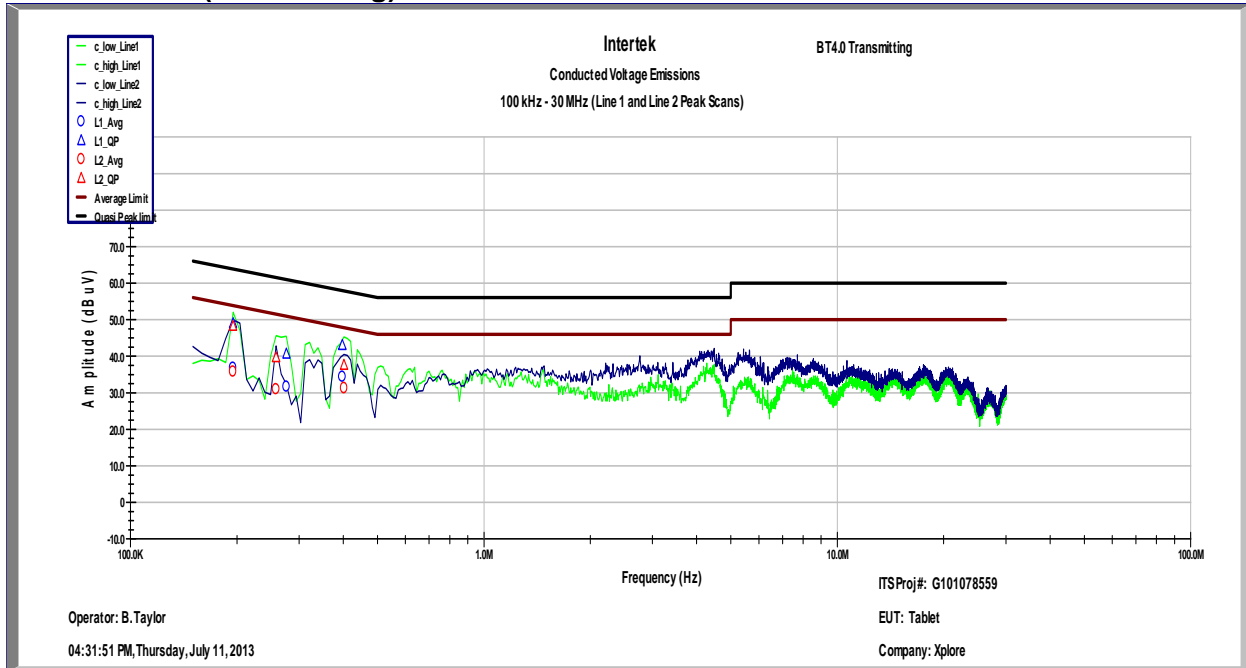

Conducted Voltage Emissions on Power Lines								
Test Engineer:	Bryan Taylor	Start Date:	7/11/2013	End Date:	7/11/2014			
Temperature:	22.8C	Humidity:	45.40%	Pressure:	991.8mBar			
Specification:	FCC Part 15	Test Limit:	Class B	RBW:	9kHz			
Notes:	BT 4.0 Radio Transmitting							
Line	Frequency (MHz)	Quasi-Peak (dBuV)	Quasi-Peak Limit (dBuV)	Quasi-Peak Delta (dB)	Average (dBuV)	Average Limit (dBuV)	Average Delta (dB)	Results
Line 1	195.0 KHz	48.92	63.82	-14.9	36.77	53.82	-17.05	Compliant
Line 1	276.0 KHz	40.64	60.94	-20.3	31.55	50.94	-19.39	Compliant
Line 1	397.4 KHz	42.96	57.91	-14.95	34.28	47.91	-13.63	Compliant
Line 2	195.0 KHz	48.2	63.82	-15.62	35.69	53.82	-18.13	Compliant
Line 2	258.0 KHz	39.62	61.5	-21.88	30.96	51.5	-20.54	Compliant
Line 2	402.0 KHz	37.55	57.81	-20.27	31.22	47.81	-16.6	Compliant

Deviations, Additions, or Exclusions: None

10.6 Data (Idle Mode):

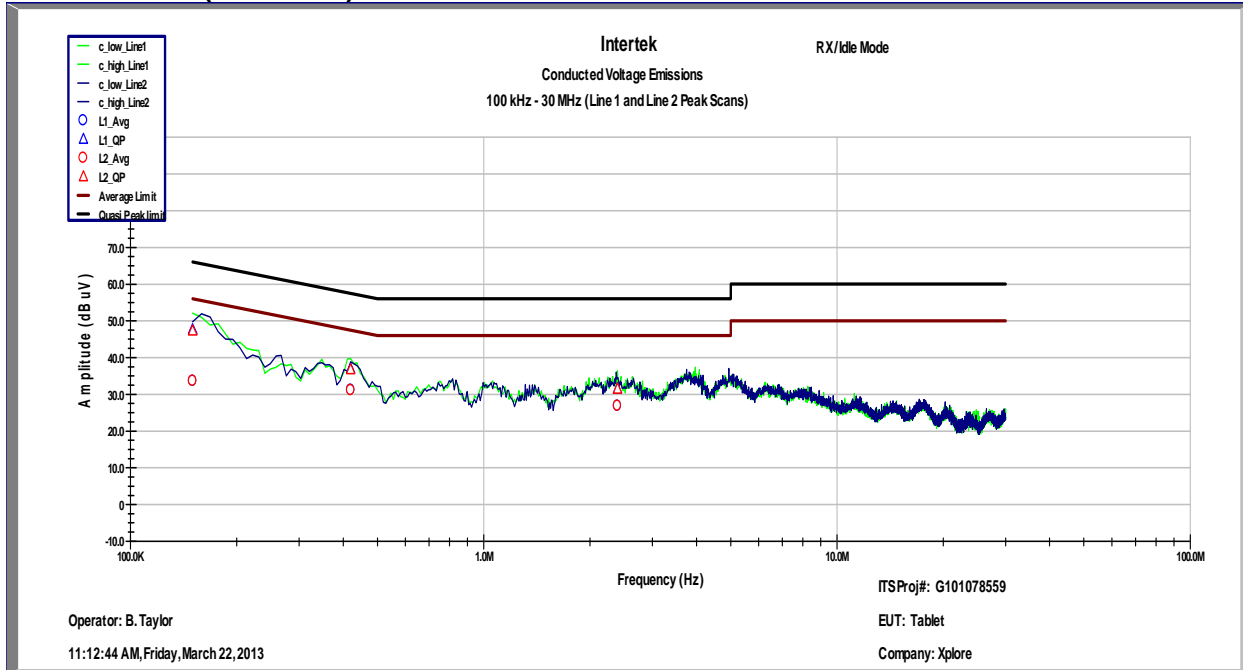

Conducted Voltage Emissions on Power Lines								
Test Engineer:	Bryan Taylor	Start Date:	3/21/2013	End Date:	3/21/2013			
Temperature:	23.4C	Humidity:	38.20%	Pressure:	987.8mBar			
	FCC Part 15 /							
Specification:	EN55022	Test Limit:	Class B	RBW:	9kHz			
Notes:	Idle Mode							
Line	Frequency (MHz)	Quasi-Peak (dBuV)	Quasi-Peak Limit (dBuV)	Quasi-Peak Delta (dB)	Average (dBuV)	Average Limit (dBuV)	Average Delta (dB)	Results
Line 1	150.0 KHz	47.66	66	-18.34	33.64	56	-22.36	Compliant
Line 1	420.0 KHz	36.94	57.45	-20.51	31.2	47.45	-16.25	Compliant
Line 1	2.391 MHz	31.47	56	-24.53	26.82	46	-19.18	Compliant
Line 2	150.0 KHz	47.29	66	-18.71	33.57	56	-22.43	Compliant
Line 2	420.0 KHz	36.73	57.45	-20.72	31.1	47.45	-16.35	Compliant
Line 2	2.391 MHz	31.47	56	-24.53	26.85	46	-19.15	Compliant

Deviations, Additions, or Exclusions: None

11 Antenna Requirement per FCC Part 15.203**11.1 Test Limits**

§ 15.203: An intentional radiator shall be designed to ensure that no antenna other than that furnished by the responsible party shall be used with the device. The use of a permanently attached antenna or of an antenna that uses a unique coupling to the intentional radiator shall be considered sufficient to comply with the provisions of this section. The manufacturer may design the unit so that a broken antenna can be replaced by the user, but the use of a standard antenna jack or electrical connector is prohibited. This requirement does not apply to carrier current devices or to devices operated under the provisions of §15.211, §15.213, §15.217, §15.219, or §15.221. Further, this requirement does not apply to intentional radiators that must be professionally installed, such as perimeter protection systems and some field disturbance sensors, or to other intentional radiators which, in accordance with §15.31(d), must be measured at the installation site. However, the installer shall be responsible for ensuring that the proper antenna is employed so that the limits in this part are not exceeded.

11.2 Results:

The sample tested met the antenna requirement. The antenna utilized a U.fl connector for connection to the PCB antenna.

12 Measurement Uncertainty

The measured value related to the corresponding limit will be used to decide whether the equipment meets the requirements.

The measurement uncertainty figures were calculated and correspond to a coverage factor of $k = 2$, providing a confidence level of respectively 95.45 % in the case where the distributions characterizing the actual measurement uncertainties are normal (Gaussian).

Measurement uncertainty Table

Parameter	Uncertainty	Notes
Radiated emissions, 30 to 1000 MHz	+3.9dB	
Radiated emissions, 1 to 18 GHz	+4.2dB	
Radiated emissions, 18 to 40 GHz	+4.3dB	
Power Port Conducted emissions, 150kHz to 30 MHz	+2.8dB	

13 Revision History

Revision Level	Date	Report Number	Notes
0	7/25/2013	101078559LEX-015a	Original Issue
1	10/1/2011	101078559LEX-015a	Editorial Corrections