



731 Enterprise Drive
Lexington, KY 40510

Telephone: 859-226-1000
Facsimile: 859-226-1040
www.intertek-etlsemko.com

TEST REPORT

Report Number: 101078559LEX-001

Project Number: G101078559

Evaluation of Model Number: iX101T1

FCCID: Q2GWG7550

ICID: 4596A-WG7550

**Tested to the SAR Criteria in
FCC OET Bulletin 65, Supplement C (Edition 01-01)
Industry Canada RSS-102 Issue 4**

For

Xplore Technologies

Test Performed by:

Intertek
731 Enterprise Drive
Lexington, KY 40510

Test Authorized by:

Xplore Technologies
1400 Summit Dr
Austin, TX 78728

Prepared By: Jason Centers Date: 6/10/2013

Jason Centers, Senior Project Engineer

Approved By: Bryan Taylor Date: 6/10/2013

Bryan Taylor, Team Leader

This report is for the exclusive use of Intertek's Client and is provided pursuant to the agreement between Intertek and its Client. Intertek's responsibility and liability are limited to the terms and conditions of the agreement. Intertek assumes no liability to any party, other than to the Client in accordance with the agreement, for any loss, expense or damage occasioned by the use of this report. Only the Client is authorized to permit copying or distribution of this report and then only in its entirety. Any use of the Intertek name or one of its marks for the sale or advertisement of the tested material, product or service must first be approved in writing by Intertek. The observations and test results in this report are relevant only to the sample tested. This report by itself does not imply that the material, product, or service is or has ever been under an Intertek certification program.



TABLE OF CONTENTS

1.0 DOCUMENT HISTORY 3

2.0 INTRODUCTION..... 4
MODIFICATIONS MADE TO TEST SAMPLE 4

3.0 TEST SITE DESCRIPTION..... 5
MEASUREMENT EQUIPMENT 6
MEASUREMENT UNCERTAINTY 7

4.0 JOB DESCRIPTION 9

5.0 SYSTEM VERIFICATION 12
SYSTEM VALIDATION..... 12
TISSUE SIMULATING LIQUID DESCRIPTION AND VALIDATION 13

6.0 EVALUATION PROCEDURES 15
TEST POSITIONS: 15
REFERENCE POWER MEASUREMENT: 15
AREA SCAN: 15
ZOOM SCAN: 15
INTERPOLATION, EXTRAPOLATION AND DETECTION OF MAXIMA: 17
POWER DRIFT MEASUREMENT: 18
RF AMBIENT ACTIVITY:..... 18

7.0 TEST CONFIGURATION..... 19

8.0 CRITERIA..... 20

9.0 TABULAR TEST RESULTS..... 21
CONDUCTED POWER MEASUREMENTS 21
SAR TEST EXCLUSIONS 24
BODY MODE SAR TEST RESULTS..... 25
SIMULTANEOUS TRANSMISSION TEST RESULTS 26

10.0 REFERENCES 27

11.0 APPENDIX A – SAR PLOTS 28

12.0 APPENDIX B – SYSTEM VERIFICATION PLOTS 56

13.0 APPENDIX C – SYSTEM VALIDATION SUMMARY 66

1.0 DOCUMENT HISTORY

Revision/ Project Number	Writer Initials	Date	Change
1.0 /G101078559	JC	6/10/2013	Original document

2.0 INTRODUCTION

At the request of Xplore Technologies, the Rugged Tablet was evaluated for SAR in accordance with the requirements for RF Exposure compliance testing defined in FCC OET Bulletin 65, Supplement C (Edition 01-01). Testing was performed at the Intertek facility in Lexington, Kentucky.

For the evaluation, the dosimetric assessment system DASY52 was used. The total uncertainty for the evaluation of the spatial peak SAR values averaged over a cube of 1g tissue mass had been assessed for this system to be $\pm 21.4\%$.

The iX101T1 was tested at the maximum output power measured by Intertek. Maximum output power measurements are tabulated under 9.0 Tabular Test Results.

The maximum spatial peak SAR value for the sample device averaged over 1g was found to be:

Transmit Band (MHz)	Mode	Channel	Frequency (MHz)	Conducted Output Power (dBm)	Reported SAR _{1g} – Body Mode (W/kg)	Limit (W/kg)
2400-2480	802.11b/1Mbps	11	2437.0	18.47	0.59	1.6
5150-5250	802.11a/6Mbps	40	5200.0	14.47	0.65	1.6
5250-5350	802.11a/6Mbps	60	5300.0	14.5	0.74	1.6
5470-5725	802.11a/6Mbps	116	5580.0	15.91	0.79	1.6
5725-5825	802.11a/6Mbps	161	5805.0	15.3	0.79	1.6

Table 1: Maximum Measured SAR

Based on the worst-case data presented above, the Rugged Tablet was found to be **compliant** with the 1.6 mW/g requirement defined in OET Bulletin 65, Supplement C (Edition 01-01) for general population / uncontrolled exposure.

Modifications made to test sample

Intertek implemented no modifications.

3.0 TEST SITE DESCRIPTION

The SAR test site located at 731 Enterprise Drive, Lexington KY 40510 is comprised of the SPEAG model DASY 5.2 automated near-field scanning system, which is a package, optimized for dosimetric evaluation of mobile radios [3]. This system is installed in an ambient-free shielded chamber. The ambient temperature is controlled to $22.0 \pm 2^{\circ}\text{C}$. During the SAR evaluations, the RF ambient conditions are monitored continuously for signals that might interfere with the test results. The tissue simulating liquid is also stored in this area in order to keep it at the same constant ambient temperature as the room.

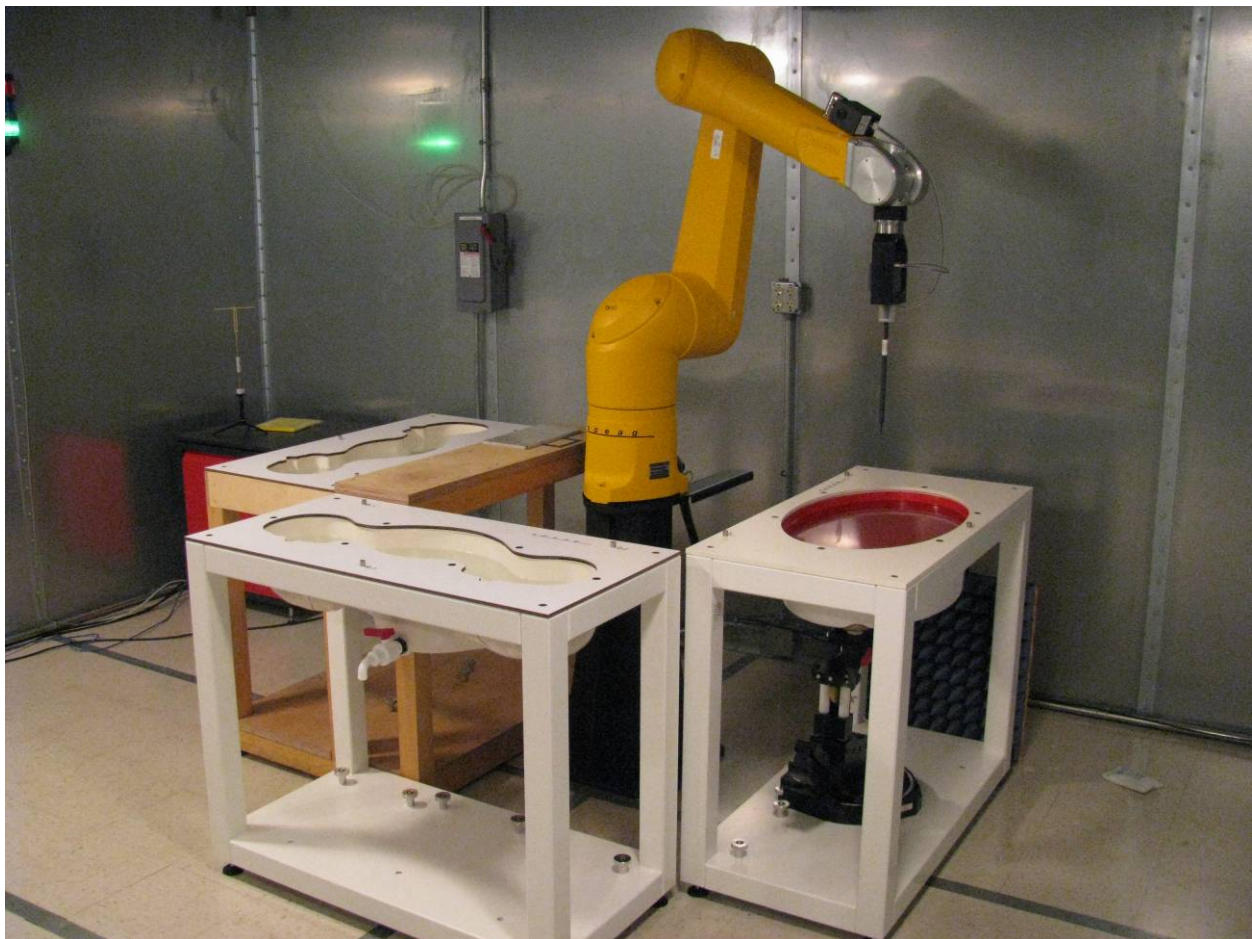

Figure 1: Intertek SAR Test Site

Measurement Equipment

The following major equipment/components were used for the SAR evaluation:

Description	Serial Number	Manufacture	Model	Cal. Date	Cal. Due	Eq. Used
SAR Probe	3516	Speag	EXDV3	12/10/12	12/10/13	<input checked="" type="checkbox"/>
System Verification Dipole	1042	Speag	D750V3	9/20/12	9/20/13	<input type="checkbox"/>
System Verification Dipole	4d122	Speag	D835V2	9/14/12	9/14/13	<input type="checkbox"/>
System Verification Dipole	13	Speag	D900V2	12/7/12	12/7/13	<input type="checkbox"/>
System Verification Dipole	224	Speag	D1800V2	12/5/12	12/5/13	<input type="checkbox"/>
System Verification Dipole	718	Speag	D2450V2	12/4/12	12/4/13	<input checked="" type="checkbox"/>
System Verification Dipole	1025	Speag	D5GHzV2	12/11/12	12/11/13	<input checked="" type="checkbox"/>
DAE	358	Speag	DAE4	9/11/12	9/11/13	<input checked="" type="checkbox"/>
Signal Generator	2065	HP	83620B	3/19/13	3/19/14	<input checked="" type="checkbox"/>
Vector Signal Generator	257708	Rohde & Schwarz	SMBV100A	5/30/13	5/30/14	<input type="checkbox"/>
Network Analyzer	US391739 83	Agilent	8753ES	3/20/13	3/20/14	<input checked="" type="checkbox"/>
Power Meter	1838538	Gigatronics	8542C	6/29/12	6/29/13	<input checked="" type="checkbox"/>
Power Sensor	1830320	Gigatronics	80601A	6/29/12	6/29/13	<input checked="" type="checkbox"/>
USB Power Sensor	100705	Rohde & Schwarz	NRP-Z51	9/1/12	9/1/13	<input checked="" type="checkbox"/>
Spectrum Analyzer	3099	Rohde & Schwarz	FSP7	9/11/12	9/11/13	<input checked="" type="checkbox"/>
Base Station Simulator	100401	Rohde & Schwarz	CMU200	8/12/12	8/12/13	<input type="checkbox"/>
Base Station Simulator	1065295	Rohde & Schwarz	CMW500	6/14/12	6/14/13	<input type="checkbox"/>
Dielectric Probe Kit	3080	Agilent	85070D	NCR	NCR	<input checked="" type="checkbox"/>
Dielectric Probe Kit	1111	Speag	DAK-3.5	NCR	NCR	<input type="checkbox"/>
ELI5 Phantom	1144	Speag	QDOVA002AA	NCR	NCR	<input type="checkbox"/>
Twin SAM Phantom	1663	Speag	QD000P40CD	NCR	NCR	<input checked="" type="checkbox"/>
Twin SAM Phantom	1243	Speag	QD000P40CA	NCR	NCR	<input checked="" type="checkbox"/>
6-axis robot	F11/5H1Y A/A/01	Staubli	RX-90	NCR	NCR	<input checked="" type="checkbox"/>

NCR – No Calibration Required

Table 2: Test Equipment Used for SAR Evaluation

Measurement Uncertainty

The Table below includes the uncertainty budget suggested by the IEEE Std 1528-2003 and determined by SPEAG for the DASY5 measurement System.

Error Description	Uncertainty Value	Prob. Dist.	Div.	c_i (1g)	c_i (10g)	Std.Unc. (1g)	Std.Unc. (10g)	$(v_i)_{v_{eff}}$
Measurement System								
Probe Calibration	±5.5%	N	1	1	1	±5.5%	±5.5%	∞
Axial Isotropy	±4.7%	R	√3	0.7	0.7	±1.9%	±1.9%	∞
Hemispherical Isotropy	±9.6%	R	√3	0.7	0.7	±3.9%	±3.9%	∞
Boundary Effect	±1.0%	R	√3	1	1	±0.6%	±0.6%	∞
Linearity	±4.7%	R	√3	1	1	±2.7%	±2.7%	∞
System Detection Limits	±1.0%	R	√3	1	1	±0.6%	±0.6%	∞
Readout Electronics	±0.3%	N	1	1	1	±0.3%	±0.3%	∞
Response Time	±0.8%	R	√3	1	1	±0.5%	±0.5%	∞
Integration Time	±2.6%	R	√3	1	1	±1.5%	±1.5%	∞
RF Ambient Noise	±3.0%	R	√3	1	1	±1.7%	±1.7%	∞
RF Ambient Reflections	±3.0%	R	√3	1	1	±1.7%	±1.7%	∞
Probe Positioner	±0.4%	R	√3	1	1	±0.2%	±0.2%	∞
Probe Positioning	±2.9%	R	√3	1	1	±1.7%	±1.7%	∞
Max. SAR Eval.	±1.0%	R	√3	1	1	±0.6%	±0.6%	∞
Test sample Related								
Device Positioning	±2.9%	N	1	1	1	±2.9%	±2.9%	145
Device Holder	±3.6%	N	1	1	1	±3.6%	±3.6%	5
Power Drift	±5.0%	R	√3	1	1	±2.9%	±2.9%	∞
Phantom and Setup								
Phantom Uncertainty	±4.0%	R	√3	1	1	±2.3%	±2.3%	∞
Liquid Conductivity (target)	±5.0%	R	√3	0.64	0.43	±1.8%	±1.2%	∞
Liquid Conductivity (meas.)	±2.5%	N	1	0.64	0.43	±1.6%	±1.1%	∞
Liquid Permittivity (target)	±5.0%	R	√3	0.6	0.49	±1.7%	±1.4%	∞
Liquid Permittivity (meas.)	±2.5%	N	1	0.6	0.49	±1.5%	±1.2%	∞
Combined Standard Uncertainty						±10.7%	±10.5%	387
Expanded STD Uncertainty						±21.4%	±21.0%	

Notes.

1. Worst Case uncertainty budget for DASY5 assessed according to IEEE 1528-2003. The budget is valid for the frequency range 300 MHz – 3 GHz and represents a worst-case analysis. For specific tests and configurations, the uncertainty could be considerably smaller.

Error Description	Uncertainty Value	Prob. Dist.	Div.	c_i (1g)	c_i (10g)	Std.Unc. (1g)	Std.Unc. (10g)	$(v_i) v_{eff}$
Measurement System								
Probe Calibration	±6.55%	N	1	1	1	±6.55%	±6.55%	∞
Axial Isotropy	±4.7%	R	√3	0.7	0.7	±1.9%	±1.9%	∞
Hemispherical Isotropy	±9.6%	R	√3	0.7	0.7	±3.9%	±3.9%	∞
Boundary Effect	±2.0%	R	√3	1	1	±1.2%	±1.2%	∞
Linearity	±4.7%	R	√3	1	1	±2.7%	±2.7%	∞
System Detection Limits	±1.0%	R	√3	1	1	±0.6%	±0.6%	∞
Readout Electronics	±0.3%	N	1	1	1	±0.3%	±0.3%	∞
Response Time	±0.8%	R	√3	1	1	±0.5%	±0.5%	∞
Integration Time	±2.6%	R	√3	1	1	±1.5%	±1.5%	∞
RF Ambient Noise	±3.0%	R	√3	1	1	±1.7%	±1.7%	∞
RF Ambient Reflections	±3.0%	R	√3	1	1	±1.7%	±1.7%	∞
Probe Positioner	±0.8%	R	√3	1	1	±0.5%	±0.5%	∞
Probe Positioning	±9.9%	R	√3	1	1	±5.7%	±5.7%	∞
Max. SAR Eval.	±4.0%	R	√3	1	1	±2.3%	±2.3%	∞
Test sample Related								
Device Positioning	±2.9%	N	1	1	1	±2.9%	±2.9%	145
Device Holder	±3.6%	N	1	1	1	±3.6%	±3.6%	5
Power Drift	±5.0%	R	√3	1	1	±2.9%	±2.9%	∞
Phantom and Setup								
Phantom Uncertainty	±4.0%	R	√3	1	1	±2.3%	±2.3%	∞
Liquid Conductivity (target)	±5.0%	R	√3	0.64	0.43	±1.8%	±1.2%	∞
Liquid Conductivity (meas.)	±2.5%	N	1	0.64	0.43	±1.6%	±1.1%	∞
Liquid Permittivity (target)	±5.0%	R	√3	0.6	0.49	±1.7%	±1.4%	∞
Liquid Permittivity (meas.)	±2.5%	N	1	0.6	0.49	±1.5%	±1.2%	∞
Combined Standard Uncertainty						±12.8%	±12.8%	330
Expanded STD Uncertainty						±25.6%	±25.2%	

Notes.

Worst Case uncertainty budget for DASY5 assessed according to IEEE 1528-2003. The budget is valid for the frequency range 3 GHz – 6 GHz and represents a worst-case analysis. Probe calibration error reflects uncertainty of the EX3D probe. For specific tests and configurations, the uncertainty could be considerably smaller.

4.0 JOB DESCRIPTION

At the request of Xplore Technologies, the iX101T1 was evaluated to the requirements defined in OET Bulletin 65, Supplement C.

Test sample	
Manufacturer	Xplore Technologies
Model Number	iX101T1
Serial Number	SYS00BO0010
Receive Date	2/19/2013
Device Received Condition	Good
Device Category	Portable
RF Exposure Category	General Population/Uncontrolled Environment
Antenna Type	Internal
Test sample Accessories	
Battery Pack	Li Polymer Battery 3.7V 9600mAh/35.52 Wh
Power Supply	Elementech International Co. Ltd. Model: AU12412030
Contact Information	
Contact Name	Dave Gosline
Phone Number	(888) 449-7567
Email Address	dgosline@xploretech.com

Table 3: Product Information

Operating Bands	Frequency Range (MHz)	Modulation	Duty Cycle
2.4GHz ISM	2400-2480	802.11b/g/n	1:1
2.4GHz ISM	2400-2480	Bluetooth	1:1
5GHz	5150-5250	802.11a/n	1:1
5GHz	5250-5350	802.11a/n	1:1
5GHz	5470-5725	802.11a/n	1:1
5GHz	5725-5825	802.11a/n	1:1
FM	88-108	FM	1:1

Table 4: Operating Bands

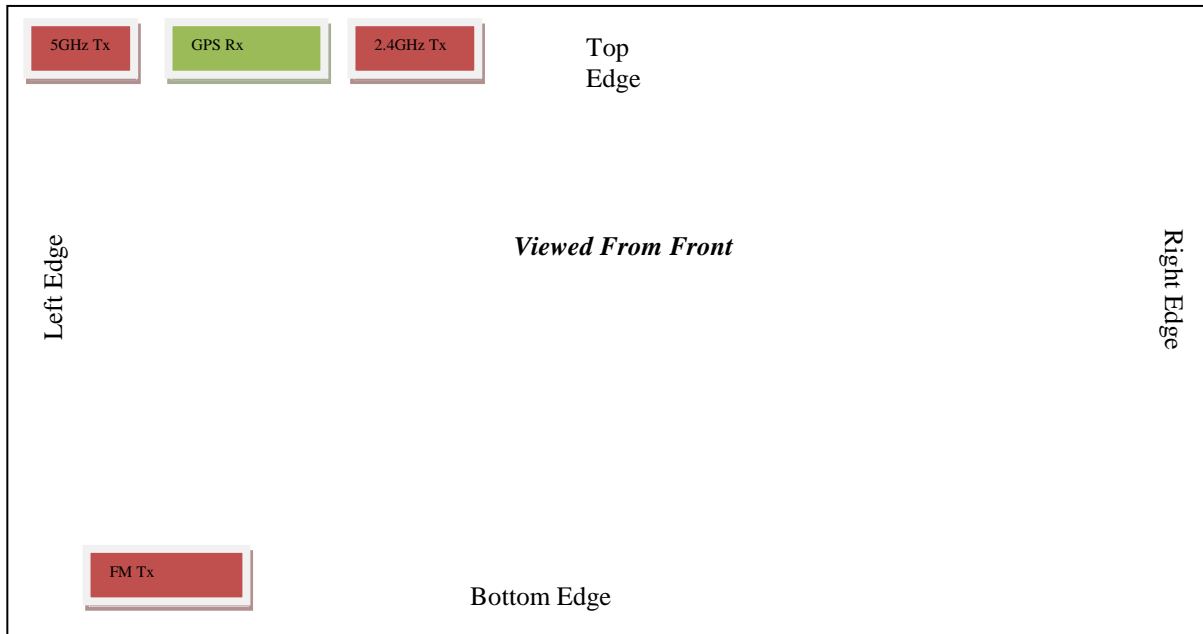

Figure 2: Antenna Locations (Viewed from Front of Tablet)

	Separation Distances (mm)		
	2.4GHz Ant.	5GHz Ant.	FM Ant.
2.4GHz Ant.			
5GHz Ant.	52.1		
FM Ant.	156.9	152.12	
Top Edge	11.32	11.32	174.5
Left Edge	94.5	23.5	36.1
Right Edge	175.9	246.6	228.8
Bottom Edge	164.2	169.4	10.9

Table 5: Antenna Separation Distances

Surface/Location	Distance (mm)
Bottom Edge/WWAN	4.7
Top Edge/WLAN/Bluetooth (2.4GHz)	4.9
Top Edge/WLAN (5GHz)	NA
Back Surface	1.5
Side Edges	3.2

Table 6: Separation Distance Introduced by Edge Bumpers¹

¹ The bumper spacing was measured with a production sample by placing the sample on a flat surface and measuring the distance with guage blocks.

5.0 SYSTEM VERIFICATION

System Validation

Prior to the assessment, the system was verified to be within $\pm 10\%$ of the specifications by using the system validation kit. The system validation procedure tests the system against reference SAR values and the performance of probe, readout electronics and software. The test setup utilizes a phantom and reference dipole. The results from the system verifications with a dipole are shown in Table 7.

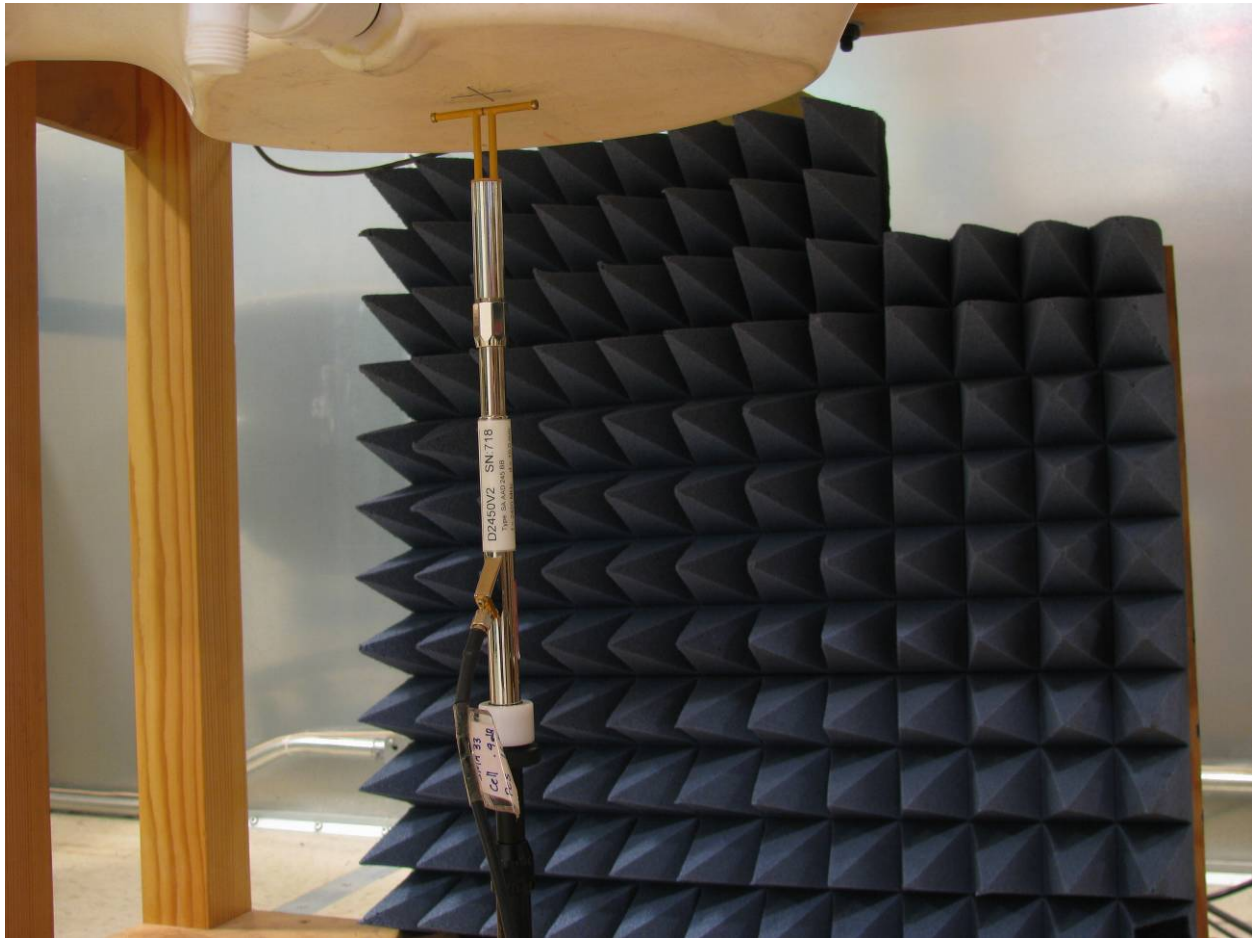

Figure 3: System Verification Setup

Reference Dipole Validation									
Ambient Temp (°C)	Fluid Temp (°C)	Frequency (MHz)	Dipole	Fluid Type	Dipole Power Input	Cal. Lab SAR (1g)	Measured SAR (1g)	% Error SAR (1g)	Date
23.6	22.5	2450	D2450V2	MSL2450	1W	51.5	53.8	4.47	4/3/13
22.9	22.1	2450	D2450V2	MSL2450	1W	51.5	50.6	1.75	4/4/13
23.1	22.1	5200	D5GHzV2	MSL5GHz	1W	72.2	71.1	1.52	4/24/13
23.1	22.1	5500	D5GHzV2	MSL5GHz	1W	77.7	76.5	1.54	4/24/13
23.1	22.1	5800	D5GHzV2	MSL5GHz	1W	72.9	70.8	2.88	4/24/13

Table 7: Dipole Validation

Tissue Simulating Liquid Description and Validation

The dielectric parameters were verified to be within 5% of the target values prior to assessment. The dielectric parameters (ϵ_r, σ) are shown in Table 8. A recipe for the tissue simulating fluid used is shown in Table 9.

Measured Tissue Properties									
Tissue Type	Frequency Measure (MHz)	Dielectric Constant Target	Conductivity Target	Dielectric Constant Measure	Imaginary Part	Conductivity Measure	Dielectric % Deviation	Conductivity % Deviation	Date
2450MSL	2400	52.77	1.95	51.48	14.53	1.94	2.44	0.58	4/3/12
	2450	52.7	1.95	51.33	14.65	1.9955	2.60	2.33	4/3/12
	2480	52.66	1.95	51.18	14.81	2.0420	2.81	4.72	4/3/12

Measured Tissue Properties									
Tissue Type	Frequency Measure (MHz)	Dielectric Constant Target	Conductivity Target	Dielectric Constant Measure	Imaginary Part	Conductivity Measure	Dielectric % Deviation	Conductivity % Deviation	Date
5GHz MSL	5200	49	5.3	49.25	18.88	5.46	0.51	2.98	4/24/13
	5300	48.9	5.42	49.08	18.99	5.5955	0.37	3.24	4/24/13
	5320	48.85	5.45	49.02	19.03	5.6285	0.35	3.27	4/24/13
	5500	48.6	5.65	48.74	19.19	5.8678	0.29	3.86	4/24/13
	5580	48.5	5.74	48.61	19.25	5.9718	0.23	4.04	4/24/13
	5800	48.2	6	48.23	19.52	6.2943	0.06	4.91	4/24/13

Table 8: Dielectric Parameter Validation

Table 9: Tissue Simulating Fluid Recipe

TYPICAL COMPOSITION OF INGREDIENTS FOR LIQUID TISSUE PHANTOMS, Supplement C Edition 01-01 to OET Bulletin 65 Edition 97-01, Page 36. (450MHz to 2450 MHz data only)												
Ingredient (% by weight)	f (MHz)											
	450		835		915		1900		2450		5500	
Tissue Type	Head	Body	Head	Body	Head	Body	Head	Body	Head	Body	Head	Body
Water	38.56	51.16	41.45	52.4	41.05	56	54.9	70.45	62.7	68.64	65.53	78.67
Salt (NaCl)	3.95	1.49	1.45	1.4	1.35	0.76	0.18	0.36	0.5	0	0	0
Sugar	56.32	46.78	56	45	56.5	41.76	0	0	0	0	0	0
HEC	0.98	0.52	1	1	1	1.21	0	0	0	0	0	0
Bactericide	0.19	0.05	0.1	0.1	0.1	0.27	0	0	0	0	0	0
Triton X-100	0	0	0	0	0	0	0	0	36.8	0	17.235	10.665
DGBE	0	0	0	0	0	0	44.92	29.18	0	31.37	0	0
DGHE	0	0	0	0	0	0	0	0	0	0	17.235	10.665
Dielectric Constant	43.42	58	42.54	56.1	42	56.8	39.9	53.3	39.8	52.7		
Conductivity (S/m)	0.85	0.83	0.91	0.95	1	1.07	1.42	1.52	1.88	1.95		

Tissue Simulating Liquid for 5GHz, MBBL3500-5800V5 Manufactured by SPEAG (proprietary mixture)

Ingredients	(% by weight)
Water	78
Mineral oil	11
Emulsifiers	9
Additives and Salt	2

6.0 EVALUATION PROCEDURES

Prior to any testing, the appropriate fluid was used to fill the phantom to a depth of 15 cm \pm 0.2cm. The fluid parameters were verified and the dipole validation was performed as described in the previous sections.

Test Positions:

The Device was positioned against the SAM and flat phantom using the exact procedure described in Supplement C Edition 01 – 01 of Federal Communications Commission, “Evaluating Compliance with FCC Guidelines for Human Exposure to Radiofrequency Electromagnetic Fields”, OET Bulletin 65, FCC, Washington, D.C. 20554, 1997 and KDB 447498.

Reference Power Measurement:

The measurement probe was positioned at a fixed location above the reference point. A power measurement was made with the probe above this reference position so it could be used for assessing the power drift later in the test procedure.

Area Scan:

A coarse area scan was performed in order to find the approximate location of the peak SAR value. This scan was performed with the measurement probe at a constant height in the simulating fluid. A two dimensional spline interpolation algorithm was then used to determine the peaks and gradients within the scanned area. The area scan resolution conformed to the requirements of KDB 865664 as shown in Table 10.

Zoom Scan:

A zoom scan was performed around the approximate location of the peak SAR as determined from the area scan. On the basis of this data set, the spatial peak SAR value was evaluated with the following procedure. The zoom scan resolution conformed to the requirements of KDB 865664 as shown in Table 10.

		≤ 3 GHz	> 3 GHz	
Maximum distance from closest measurement point (geometric center of probe sensors) to phantom surface		5 ± 1 mm	$\frac{1}{2} \cdot \delta \cdot \ln(2) \pm 0.5$ mm	
Maximum probe angle from probe axis to phantom surface normal at the measurement location		$30^\circ \pm 1^\circ$	$20^\circ \pm 1^\circ$	
Maximum area scan spatial resolution: Δx_{Area} , Δy_{Area}		≤ 2 GHz: ≤ 15 mm 2 – 3 GHz: ≤ 12 mm	3 – 4 GHz: ≤ 12 mm 4 – 6 GHz: ≤ 10 mm	
	When the x or y dimension of the test device, in the measurement plane orientation, is smaller than the above, the measurement resolution must be \leq the corresponding x or y dimension of the test device with at least one measurement point on the test device.			
Maximum zoom scan spatial resolution: Δx_{Zoom} , Δy_{Zoom}		≤ 2 GHz: ≤ 8 mm 2 – 3 GHz: ≤ 5 mm*	3 – 4 GHz: ≤ 5 mm* 4 – 6 GHz: ≤ 4 mm*	
Maximum zoom scan spatial resolution, normal to phantom surface	uniform grid: $\Delta z_{Zoom}(n)$	≤ 5 mm	3 – 4 GHz: ≤ 4 mm 4 – 5 GHz: ≤ 3 mm 5 – 6 GHz: ≤ 2 mm	
	graded grid	$\Delta z_{Zoom}(1)$: between 1 st two points closest to phantom surface	≤ 4 mm	3 – 4 GHz: ≤ 3 mm 4 – 5 GHz: ≤ 2.5 mm 5 – 6 GHz: ≤ 2 mm
		$\Delta z_{Zoom}(n>1)$: between subsequent points	$\leq 1.5 \cdot \Delta z_{Zoom}(n-1)$	
Minimum zoom scan volume	x, y, z	≥ 30 mm	3 – 4 GHz: ≥ 28 mm 4 – 5 GHz: ≥ 25 mm 5 – 6 GHz: ≥ 22 mm	
Note: δ is the penetration depth of a plane-wave at normal incidence to the tissue medium; see draft standard IEEE P1528-2011 for details.				
* When zoom scan is required and the <i>reported</i> SAR from the <i>area scan based 1-g SAR estimation</i> procedures of KDB 447498 is ≤ 1.4 W/kg, ≤ 8 mm, ≤ 7 mm and ≤ 5 mm zoom scan resolution may be applied, respectively, for 2 GHz to 3 GHz, 3 GHz to 4 GHz and 4 GHz to 6 GHz.				

Table 10: SAR Area and Zoom Scan Resolutions

Interpolation, Extrapolation and Detection of Maxima:

The probe is calibrated at the center of the dipole sensors which is located 1 to 2.7 mm away from the probe tip. During measurements, the probe stops shortly above the phantom surface, depending on the probe and the surface detecting system. Both distances are included as parameters in the probe configuration file. The software always knows exactly how far away the measured point is from the surface. As the probe cannot directly measure at the surface, the values between the deepest measured point and the surface must be extrapolated.

In DASYS, the choice of the coordinate system defining the location of the measurement points has no influence on the uncertainty of the interpolation, Maxima Search and extrapolation routines. The interpolation, extrapolation and maximum search routines are all based on the modified Quadratic Shepard's method.

Thereby, the interpolation scheme combines a least-square fitted function method and a weighted average method which are the two basic types of computational interpolation and approximation. The DASYS routines construct a once-continuously differentiable function that interpolates the measurement values as follows:

- For each measurement point a trivariate (3-D) / bivariate (2-D) quadratic is computed. It interpolates the measurement values at the data point and forms a least-square fit to neighboring measurement values.
- The spatial location of the quadratic with respect to the measurement values is attenuated by an inverse distance weighting. This is performed since the calculated quadratic will fit measurement values at nearby points more accurate than at points located further away.
- After the quadratics are calculated for at all measurement points, the interpolating function is calculated as a weighted average of the quadratics.

There are two control parameters that govern the behavior of the interpolation method. One specifies the number of measurement points to be used in computing the least-square fits for the local quadratics. These measurement points are the ones nearest the input point for which the quadratic is being computed. The second parameter specifies the number of measurement points that will be used in calculating the weights for the quadratics to produce the final function. The input data points used there are the ones nearest the point at which the interpolation is desired. Appropriate defaults are chosen for each of the control parameters.

The trivariate quadratics that have been previously computed for the 3-D interpolation and whose input data are at the closest distance from the phantom surface, are used in order to extrapolate the fields to the surface of the phantom.

In order to determine all the field maxima in 2-D (Area Scan) and 3-D (Zoom Scan), the measurement grid is refined by a default factor of 10 and the interpolation function is used to evaluate all field values between corresponding measurement points. Subsequently, a linear search is applied to find all the candidate maxima. In a last step, non-physical maxima are removed and only those maxima which are within 2 dB of the global maximum value are retained.

Averaging and Determination of Spatial Peak SAR

The interpolated data is used to average the SAR over the 1g and 10g cubes by spatially discretizing the entire measured volume. The resolution of this spatial grid used to calculate the averaged SAR is 1mm or about 42875 interpolated points. The resulting volumes are defined as cubical volumes containing the appropriate tissue parameters that are centered at the location. The location is defined as the center of the incremental volume.

The spatial-peak SAR must be evaluated in cubical volumes containing a mass that is within 5% of the required mass. The cubical volume centered at each location, as defined above, should be expanded in all directions until the desired value for the mass is reached, with no surface boundaries of the averaging volume extending beyond the outermost surface of the considered region. In addition, the cubical volume should not consist of more than 10% of air. If these conditions are not satisfied then the center of the averaging volume is moved to the next location. Otherwise, the exact size of the final sampling cube is found using an inverse polynomial approximation algorithm, leading to results with improved accuracy. If one boundary of the averaging volume reaches the boundary of the measured volume during its expansion, it will not be evaluated at all. Reference is kept of all locations used and those not used for averaging the SAR. All average SAR values are finally assigned to the centered location in each valid averaging volume.

All locations included in an averaging volume are marked to indicate that they have been used at least once. If a location has been marked as used, but has never been assigned to the center of a cube, the highest averaged SAR value of all other cubical volumes which have used this location for averaging is assigned to this location. Only those locations that are not part of any valid averaging volume should be marked as unused. For the case of an unused location, a new averaging volume must be constructed which will have the unused location centered at one surface of the cube. The remaining five surfaces are expanded evenly in all directions until the required mass is enclosed, regardless of the amount of included air. Of the six possible cubes with one surface centered on the unused location, the smallest cube is used, which still contains the required mass.

If the final cube containing the highest averaged SAR touches the surface of the measured volume, an appropriate warning is issued within the postprocessing engine.

Power Drift Measurement:

The probe was positioned at precisely the same reference point and the reference power measurement was repeated. The difference between the initial reference power and the final one is referred to as the power drift. The power drift measurement was used to assess the output power stability of the test sample throughout the SAR scan.

RF Ambient Activity:

During the entire SAR evaluation, the RF ambient activity was monitored using a spectrum analyzer with an antenna connected to it. The spectrum analyzer was tuned to the frequency of measurement and with one trace set to max hold mode. In this way, it was possible to determine if at any point during the SAR measurement there was an interfering ambient signal. If an ambient signal was detected, then the SAR measurement was repeated.

7.0 TEST CONFIGURATION

For the purpose of this evaluation, the iX101T1 was considered to be a device that could be operated when held against the body. All SAR scans were performed with a freshly charged battery installed.

The test channels and operating modes were selected using software based test commands for the evaluation of the WLAN radio. The device was positioned against the bottom of the phantom with zero clearance during the evaluation. The test positions were performed as described in KDB 616217.

8.0 CRITERIA

The following FCC limits for SAR apply to portable devices operating in the General Population/Uncontrolled Exposure environment:

Exposure (General Population/Uncontrolled Exposure environment)	SAR (W/kg)
Average over the whole body	0.08
Spatial Peak (1g)	1.60
Spatial Peak for hands, wrists, feet and ankles (10g)	4.00

9.0 TABULAR TEST RESULTS

The results on the following page(s) were obtained when the device was transmitting at maximum output power. Detailed measurement data and plots, which reveal information about the location of the maximum SAR with respect to the device, are referenced under APPENDIX A – SAR Plots.

Conducted Power Measurements

The conducted power measurements for the 802.11 module in the iX101T1 were performed in accordance to ANSI C63.19:2009 and KDBs 558074 and 789033 for DTS and UNII devices using the channel power integration method. The measurements shown below are average power measurements and were used for the selection of channel and data rate for SAR measurements in accordance with KDB 248227.

Channel	Frequency (MHz)	Data Rate	Output Power (dBm)	Limit (dBm)	Pass / Fail
Low	2402	1Mbps	-5.87dBm	30dBm	Pass
Mid	2441	1Mbps	-5.87dBm	30dBm	Pass
High	2480	1Mbps	-5.30dBm	30dBm	Pass
Low	2402	2Mbps	6.86dBm	30dBm	Pass
Mid	2441	2Mbps	6.41dBm	30dBm	Pass
High	2480	2Mbps	6.35dBm	30dBm	Pass
Low	2402	3Mbps	-2.99dBm	30dBm	Pass
Mid	2441	3Mbps	-2.87dBm	30dBm	Pass
High	2480	3Mbps	-2.4dBm	30dBm	Pass

Table 11: Conducted Output Power – Bluetooth

Mode	Channel Number	Frequency (MHz)	Peak Output Power (dBm)	Limit (dBm)	Result
BT4.0	0	2402	7.96	30	Pass
BT4.0	19	2440	8.08	30	Pass
BT4.0	39	2480	8.24	30	Pass

Table 12: Conducted Output Power – Bluetooth LE Mode

Mode	Frequency (MHz)	Channel Number	Conducted Power (dBm)			
			Data Rate (Mbps)			
			1	2	5.5	11
802.11b	2412	1	18.34	18.34	19.04	19.19
	2437	6	17.98	18.16	19.21	19.18
	2462	11	18.57	18.62	19.58	19.7

Table 13: Conducted Output Power – 802.11b - 2.4GHz

Mode	Frequency (MHz)	Channel Number	Conducted Power (dBm)							
			Data Rate (Mbps)							
			6	9	12	18	24	36	48	54
802.11g	2412	1	18.21	18.28	18.16	18.02	16.59	16.56	14.62	14.68
	2437	6	18.47	18.23	18.2	18.03	16.56	16.4	15.28	15.24
	2462	11	18.48	18.53	18.18	18.25	16.63	16.52	15.28	15.22

Table 14: Conducted Output Power – 802.11g - 2.4GHz

Mode	Frequency (MHz)	Channel Number	Conducted Power (dBm)							
			MCS0	MCS1	MCS2	MCS3	MCS4	MCS5	MCS6	MCS7
802.11n	2412	1	17.19	17.18	17.75	16.33	16.24	16.38	14.77	13.95
	2437	6	17.27	17.91	17.94	16.42	16.62	15.32	14.98	14.28
	2462	11	17.5	18.06	17.69	16.97	16.75	15.12	15.25	14.31

Table 15: Conducted Output Power – 802.11n - 2.4GHz

Mode	Frequency (MHz)	Channel Number	Conducted Power (dBm)							
			Data Rate (Mbps)							
			6	9	12	18	24	36	48	54
802.11a	5180	36	15.97	15.9	15.16	15.17	14.58	14.57	12.48	13.29
	5200	40	16.46	16.25	15.45	15.48	14.91	14.77	13.44	13.68
	5220	44	16.36	16.33	16.32	15.5	14.95	14.96	13.68	13.77
	5240	48	16.1	16.13	15.12	15.15	14.76	14.56	13.17	13.3
	5260	52	16.15	16.15	15.47	15.32	14.74	14.87	13.66	13.7
	5280	56	16.44	16.25	15.47	15.42	15	14.97	13.67	13.69
	5300	60	16.56	16.47	15.64	15.65	14.95	15.12	13.76	13.69
	5320	64	16.19	16.25	15.31	15.44	14.86	15.17	13.67	13.4
	5500	100	17.02	16.92	16.21	16.14	15.55	15.48	14.1	14.34
	5520	104	17.03	17.06	16.33	16.2	15.7	15.72	14.27	14.43
	5540	108	17.18	17.16	16.4	16.32	15.9	15.72	14.3	14.3
	5560	112	17.12	17.08	16.28	16.48	16.3	15.86	14.35	14.4
	5580	116	17.4	17.15	16.34	16.46	15.71	15.66	14.39	14.37
	5600	120	17.12	17.2	16.32	16.46	15.77	15.85	14.55	14.5
	5620	124	17.22	17.15	16.32	16.4	16.36	15.87	14.59	14.43
	5640	128	17.09	17.12	16.36	16.23	15.81	15.91	14.62	14.37
	5660	132	17.04	17.18	16.37	16.36	15.77	15.85	14.41	14.46
	5680	136	16.93	17.17	16.39	16.44	16.05	15.9	14.55	14.66
	5700	140	17.38	17.38	16.49	16.34	16.02	15.98	14.65	14.58
	5745	149	17.13	16.68	16.29	16.4	15.71	15.82	14.52	14.55
5765	153	17.19	17.19	16.51	16.36	16.03	15.88	14.65	14.46	
5785	157	17.24	17.2	16.42	16.31	15.88	15.79	14.44	14.5	
5805	161	17.29	17.12	16.1	16.23	15.81	16.02	14.36	14.74	
5825	165	16.93	17.13	16.32	16.26	15.76	15.72	14.42	14.5	

Table 16: Conducted Output Power – 802.11a – 5GHz

Mode	Frequency (MHz)	Channel Number	Conducted Power (dBm)							
			MCS0	MCS1	MCS2	MCS3	MCS4	MCS5	MCS6	MCS7
802.11n Mode - 5GHz Band	5180	36	15.64	14.97	14.81	14.47	14.4	13.08	12.99	12.12
	5200	40	16.02	15.15	15.16	14.81	14.74	13.36	13.29	12.52
	5220	44	16.16	15.3	15.04	14.88	14.7	13.4	13.16	12.5
	5240	48	15.94	15.02	14.91	14.57	14.51	13.14	12.96	12.36
	5260	52	15.92	15.11	15.16	14.73	14.46	13.28	13.2	12.23
	5280	56	16.21	15.3	15.27	15.24	14.97	13.42	13.65	12.46
	5300	60	16.22	15.27	15.28	14.81	14.97	13.46	13.56	12.61
	5320	64	16.03	15.37	15.19	14.78	14.59	13.3	13.35	12.37
	5500	100	16.9	16.19	16.02	15.52	15.42	13.96	14	12.86
	5520	104	17.11	16.17	16.09	15.55	15.65	14.05	13.68	13.4
	5540	108	17.17	16.17	16.16	15.68	16.02	14.48	14.31	13.6
	5560	112	17.08	16.2	16.07	15.7	15.99	14.31	14.17	13.42
	5580	116	16.96	15.63	15.92	15.68	15.61	14.7	14.21	13.43
	5600	120	16.96	16.22	16.16	16	15.63	14.35	14.25	13.4
	5620	124	17.14	16.42	16.3	15.91	15.89	14.52	14.56	13.63
	5640	128	17.23	16.2	16.3	15.99	15.87	14.63	14.52	13.67
	5660	132	17.07	16.29	16.22	15.99	15.82	14.48	14.37	13.49
	5680	136	17.12	16.51	16.68	16.06	15.87	14.57	13.89	13.67
	5700	140	17.29	16.46	16.41	16.13	15.97	14.79	14.43	13.73
	5745	149	17.27	16.4	16.35	16.06	15.87	14.47	14.6	13.6
5765	153	17.31	16.26	16.29	15.81	15.82	14.9	14.55	13.64	
5785	157	17.36	16.32	16.22	16.12	15.86	14.64	14.55	13.78	
5805	161	17.02	16.5	16.24	15.9	16.17	14.51	14.69	13.44	
5825	165	16.96	16.16	16.09	15.68	15.75	14.43	14.35	13.16	

Table 17: Conducted Output Power – 802.11n – 5GHz

The output power on channels used for SAR measurement were measured again using the channel integration power measurement profile for 802.11 measurements to compare to the power maximum power limits defined by the manufacture for the purpose of scaling SAR measurements. This was necessary since the FCC method of measuring output power varies from the manufactures method of power measurement.

Mode	Frequency (MHz)	Channel Number	Measured Conducted Output Power (dBm)	Maximum Output Power (dBm)
802.11b	2412	1	17.91	19
	2437	6	18.41	19
	2462	11	18.47	19
802.11a	5200	40	14.47	15.5
	5240	48	14.99	15.5
	5300	60	14.5	15.5
	5320	64	15.07	15.5
	5580	116	15.91	16
	5805	161	15.3	16

Table 18: Conducted Output Power Measurements for SAR Scaling

SAR Test Exclusions

The following formulas from KDB 447498 section 4.3 were used to exclude certain edge configurations from testing based on output power and distance from the closest part of the antenna to the tablet edge (excluding additional spacing provided by bumpers) as described in KDB 616217 section 4.3 for determination of exclusion with the tablet edges. A separation distance of 5mm was used for the backside of the tablet as described in KDB 447498.

WLAN and Bluetooth Transmitters

Edges ≤ 50 mm

$$[(\text{max. power of channel, including tune-up tolerance, mW}) / (\text{min. test separation distance, mm})] * [\sqrt{f_{\text{(GHz)}}}] \leq 3.0$$

Edges > 50mm

$$[(\text{Power allowed at numeric threshold for 50mm}) + (\text{test separation distance} - 50\text{mm}) * 10] \text{ mW}$$

FM Transmitter

Since the conducted output power could not be measured, the ERP was determined from field strength measurements and used as a conservative measure of output power.

$$\text{ERP} = 0.00000962\text{mW}$$

The test exclusion for frequencies below 100 MHz and separation test distance of < 50mm is given by the following:

$$[(\text{Power allowed at numeric threshold for 50 mm}) + (\text{test separation distance} - 50\text{mm}) * (f_{\text{MHz}} / 150)] * [1 + \log(100 / f_{\text{(MHz)}}) * 1/2]$$

Antenna	Back Side	Top Edge	Bottom Edge	Right Edge	Left Edge
2.4GHz (WLAN)	Tested	Tested	Excluded	Excluded	Excluded
2.4GHz (Bluetooth)	Excluded	Excluded	Excluded	Excluded	Excluded
5GHz (WLAN)	Tested	Tested	Excluded	Excluded	Tested
FM Antenna	Excluded	Excluded	Excluded	Excluded	Excluded

Table 19: Tablet Edges Evaluated for SAR

Body Mode SAR Test Results

The device was evaluated according to the specific requirements found in FCC KDB 447498[9] and 616217[8]. The WLAN module was configured in accordance to FCC KDB 248227. The worst case 1-g SAR value was less than the 1.6mW/g limit.

The device contains proximity sensors for the purpose of power reduction for cellular transmitter options installed in the tablet. The output power of the WLAN transmitters are not affected by the operation state of the proximity sensors.

Exclusions:

- SAR in Bluetooth mode was not measured since output was below the low power threshold in KDB 447498.
- SAR in 802.11 g/n modes were not required since the output power was < 0.25dB higher than the output power in b or a modes.
- Repeatability measurements were not required since the Reported SAR was <0.8W/kg.

SAR Measurement Results at the Body - WLAN 2.4 GHz Module - Tablet Back Positioned Against Phantom												
Band	Channel	Frequency (MHz)	Mode	Battery	Test Position	Seperation Distance (mm)	Power Drift (dB)	Measured SAR 1g (W/kg)	Reported SAR 1g (W/kg)	Measured Conducted Output Power (dBm)	Maximum Conducted Output Power (dBm)	Notes
2.4GHz	1	2412.00	802.11b/1 mbps	Standard	Back Touching Phantom	0			0.00	17.91	19.00	
2.4GHz	6	2437.00	802.11b/1 mbps	Standard	Back Touching Phantom	0			0.00	18.41	19.00	
2.4GHz	11	2462.00	802.11b/1 mbps	Standard	Back Touching Phantom	0	-0.03	0.52	0.59	18.47	19.00	Plot A1
2.4GHz	11	2462.00	802.11b/11 mbps	Standard	Back Touching Phantom	0	-0.07	0.51	0.58	18.47	19.00	
SAR Measurement Results at the Body - WLAN 2.4 GHz Module - Tablet Top Edge Positioned Against Phantom												
Band	Channel	Frequency (MHz)	Mode	Battery	Test Position	Seperation Distance (mm)	Power Drift (dB)	Measured SAR 1g (W/kg)	Reported SAR 1g (W/kg)	Measured Conducted Output Power (dBm)	Maximum Conducted Output Power (dBm)	Notes
2.4GHz	1	2412.00	802.11b/1 mbps	Standard	Top Edge Touch Phantom	0			0.00	17.91	19.00	
2.4GHz	6	2437.00	802.11b/1 mbps	Standard	Top Edge Touch Phantom	0			0.00	18.41	19.00	
2.4GHz	11	2462.00	802.11b/1 mbps	Standard	Top Edge Touch Phantom	0	-0.22	0.27	0.30	18.47	19.00	Plot A2
2.4GHz	11	2462.00	802.11b/11 mbps	Standard	Top Edge Touch Phantom	0	-0.08	0.25	0.29	18.47	19.00	
SAR Measurement Results at the Body - WLAN 5 GHz Module - Tablet Back Positioned Against Phantom												
Band	Channel	Frequency (MHz)	Mode	Battery	Test Position	Seperation Distance (mm)	Power Drift (dB)	Measured SAR 1g (W/kg)	Reported SAR 1g (W/kg)	Measured Conducted Output Power (dBm)	Maximum Conducted Output Power (dBm)	Notes
5GHz	40	5200.00	802.11a/6 mbps	Standard	Back Touching Phantom	0	0.01	0.32	0.40	14.47	15.5	Plot A3
5GHz	48	5240.00	802.11a/6 mbps	Standard	Back Touching Phantom	0	0.11	0.33	0.38	14.99	15.5	
5GHz	60	5300.00	802.11a/6 mbps	Standard	Back Touching Phantom	0	-0.13	0.44	0.56	14.50	15.5	Plot A4
5GHz	116	5580.00	802.11a/6 mbps	Standard	Back Touching Phantom	0	0.07	0.482	0.49	15.91	16.0	Plot A5
5GHz	161	5805.00	802.11a/6 mbps	Standard	Back Touching Phantom	0	0.09	0.358	0.42	15.30	16.0	Plot A6
SAR Measurement Results at the Body - WLAN 5 GHz Module - Tablet Top Edge Positioned Against Phantom												
Band	Channel	Frequency (MHz)	Mode	Battery	Test Position	Seperation Distance (mm)	Power Drift (dB)	Measured SAR 1g (W/kg)	Reported SAR 1g (W/kg)	Measured Conducted Output Power (dBm)	Maximum Conducted Output Power (dBm)	Notes
5GHz	40	5200.00	802.11a/6 mbps	Standard	Top Edge Touching Phantom	0	-0.02	0.51	0.65	14.47	15.5	Plot A7
5GHz	48	5240.00	802.11a/6 mbps	Standard	Top Edge Touching Phantom	0	-0.09	0.45	0.51	14.99	15.5	
5GHz	60	5300.00	802.11a/6 mbps	Standard	Top Edge Touching Phantom	0	-0.06	0.59	0.74	14.50	15.5	Plot A8
5GHz	116	5580.00	802.11a/6 mbps	Standard	Top Edge Touching Phantom	0	0.05	0.771	0.79	15.91	16.0	Plot A9
5GHz	161	5805.00	802.11a/6 mbps	Standard	Top Edge Touching Phantom	0	0.09	0.676	0.79	15.30	16.0	Plot A10
SAR Measurement Results at the Body - WLAN 5 GHz Module - Tablet Side Edge Positioned Against Phantom												
Band	Channel	Frequency (MHz)	Mode	Battery	Test Position	Seperation Distance (mm)	Power Drift (dB)	Measured SAR 1g (W/kg)	Reported SAR 1g (W/kg)	Measured Conducted Output Power (dBm)	Maximum Conducted Output Power (dBm)	Notes
5GHz	40	5200.00	802.11a/6 mbps	Standard	Side Edge Touching Phantom	0	0.05	0.12	0.15	14.47	15.5	Plot A11
5GHz	48	5240.00	802.11a/6 mbps	Standard	Side Edge Touching Phantom	0	0.20	0.11	0.13	14.99	15.5	
5GHz	60	5300.00	802.11a/6 mbps	Standard	Side Edge Touching Phantom	0	0.07	0.15	0.18	14.50	15.5	Plot A12
5GHz	116	5580.00	802.11a/6 mbps	Standard	Side Edge Touching Phantom	0	0.10	0.197	0.20	15.91	16.0	Plot A13
5GHz	161	5805.00	802.11a/6 mbps	Standard	Side Edge Touching Phantom	0	0.16	0.202	0.24	15.30	16.0	Plot A14

Table 20: Body Mode SAR Results – WLAN

Simultaneous Transmission Test Results

The WLAN transmitter cannot operate simultaneously with the Bluetooth transmitter or the 5GHz WLAN transmitter. The tablet firmware prevents operation of the transmitters simultaneously.

The FM transmitter can operate simultaneously with the WLAN transmitter. The 1g SAR for the FM transmitter is estimated by the following formula:

$$SAR_{1g} = [(max. power of channel)/(min test separation distance)] * [\sqrt{f(ghz)}/7.5]$$

$$SAR_{1g} = [(0.00000962)/(5mm)] * [\sqrt{0.088}/7.5] = \ll 0.01 W/kg$$

The estimated SAR 1g from the FM transmitter when added to any of the 1g SAR results from the WLAN transmitter was $\ll 1.6 W/kg$. Therefore, no simultaneous SAR transmission tests are required.

10.0 REFERENCES

- [1] ANSI, *ANSI/IEEE C95.1-1991: IEEE Standard for Safety Levels with Respect to Human Exposure to Radio Frequency Electromagnetic Fields, 3kHz to 300 GHz*, The Institute of electrical and Electronics Engineers, Inc., New York, NY 10017, 1992
- [2] Federal Communications Commission, “Evaluating Compliance with FCC Guidelines for Human Exposure to Radiofrequency Electromagnetic Fields”, Supplement C (Edition 01-01) to OET Bulletin 65 (Edition 97-01), FCC, Washington, D.C. 20554, 1997
- [3] Thomas Schmid, Oliver Egger, and Niels Kuster, “Automated E-field scanning system for dosimetric assessments”, *IEEE Transaction on Microwave Theory and Techniques*, vol. 44, pp. 105-113, Jan. 1996.
- [4] Niels Kuster, Ralph Kastle, and Thomas Schmid, “Dosimetric evaluation of mobile communications equipment with know precision”, *IEICE Transactions on Communications*, vol. E80-B, no. 5, pp.645-652, May 1997.
- [5] NIS81, NAMAS, “The treatment of uncertainty in EMC measurement”, Tech. Rep., NAMAS Executive, National Physical Laboratory, Teddinton, Middlesex, England, 1994.
- [6] Barry N. Taylor and Chris E. Kuyatt, “Guidelines for evaluating and expressing the uncertainty of NIST measurement results”, Tech. Rep., National Institute of Standards and Technology, 1994.
- [7] Federal Communications Commission, KDG 248227 - “SAR Measurement Procedures for 802.11 a/b/g Transmitters”
- [8] Federal Communications Commission, KDB 648474 – “SAR Evaluation Considerations for Handsets with Multiple Transmitters and Antennas”.
- [9] Federal Communications Commission, KDB 447498 – “Mobile and Portable Device RF Exposure Procedures and Equipment Authorization Policies”.
- [10] Federal Communications Commission, KDB 616217 – “SAR Evaluation Considerations for Laptop Computers with Antennas Built-in on Display Screens”.
- [11] Federal Communications Commission, KDB 450824 – “SAR Probe Calibration and System Verification Considerations for Measurements at 150MHz – 3GHz”.
- [12] Federal Communications Commission, KDB 865664 – “SAR Measurement Requirements for 3-6GHz”.
- [13] Federal Communications Commission, KDB 941225 – “SAR Measurement Procedures for 3G Devices”.
- [14] ANSI, *ANSI/IEEE C63.10-2009: American National Standard for Testing Unlicensed Wireless Devices*.

11.0 APPENDIX A – SAR PLOTS*Plot A 1*

Date/Time: 4/3/2013 3:56:39 PM

Test Laboratory: Intertek

Tablet Back Side 802.11b Scan**DUT: Xplore Tomcat ; Type: Tablet; Serial: SYS00B00010**

Communication System: Generic 802.11b/g/n; Communication System Band: 2.4 GHz Band;
Frequency: 2462 MHz; Communication System PAR: 0 dB; PMF: 1.12202e-005
Medium parameters used (interpolated): $f = 2462$ MHz; $\sigma = 2.022$ S/m; $\epsilon_r = 51.213$; $\rho = 1000$ kg/m³

Phantom section: Flat Section

Measurement Standard: DASYS (IEEE/IEC/ANSI C63.19-2007)

DASY Configuration:

- Probe: EX3DV3 - SN3516; ConvF(7.92, 7.92, 7.92); Calibrated: 12/10/2012;
 - Modulation Compensation:
- Sensor-Surface: 2mm (Mechanical Surface Detection), $z = 1.0, 31.0$
- Electronics: DAE4 Sn358; Calibrated: 9/11/2012
- Phantom: SAM 2 with CRP v5.0; Type: QD000P40CD; Serial: TP:1663
- DASYS2 52.8.5(1059); SEMCAD X 14.6.8(7028)

Wifi Flat-Section MSL Testing on 4_3_2013/Back of Device Against Phantom,**Data Rate =1mbps/Area Scan (4x7x1):** Measurement grid: dx=12mm, dy=12mm

Maximum value of SAR (measured) = 0.768 W/kg

Wifi Flat-Section MSL Testing on 4_3_2013/Back of Device Against Phantom,**Data Rate =1mbps/Zoom Scan (7x7x7)/Cube 0:** Measurement grid: dx=5mm, dy=5mm, dz=5mm

Reference Value = 17.138 V/m; Power Drift = -0.03 dB

Peak SAR (extrapolated) = 1.07 W/kg

SAR(1 g) = 0.519 W/kg

Maximum value of SAR (measured) = 0.775 W/kg

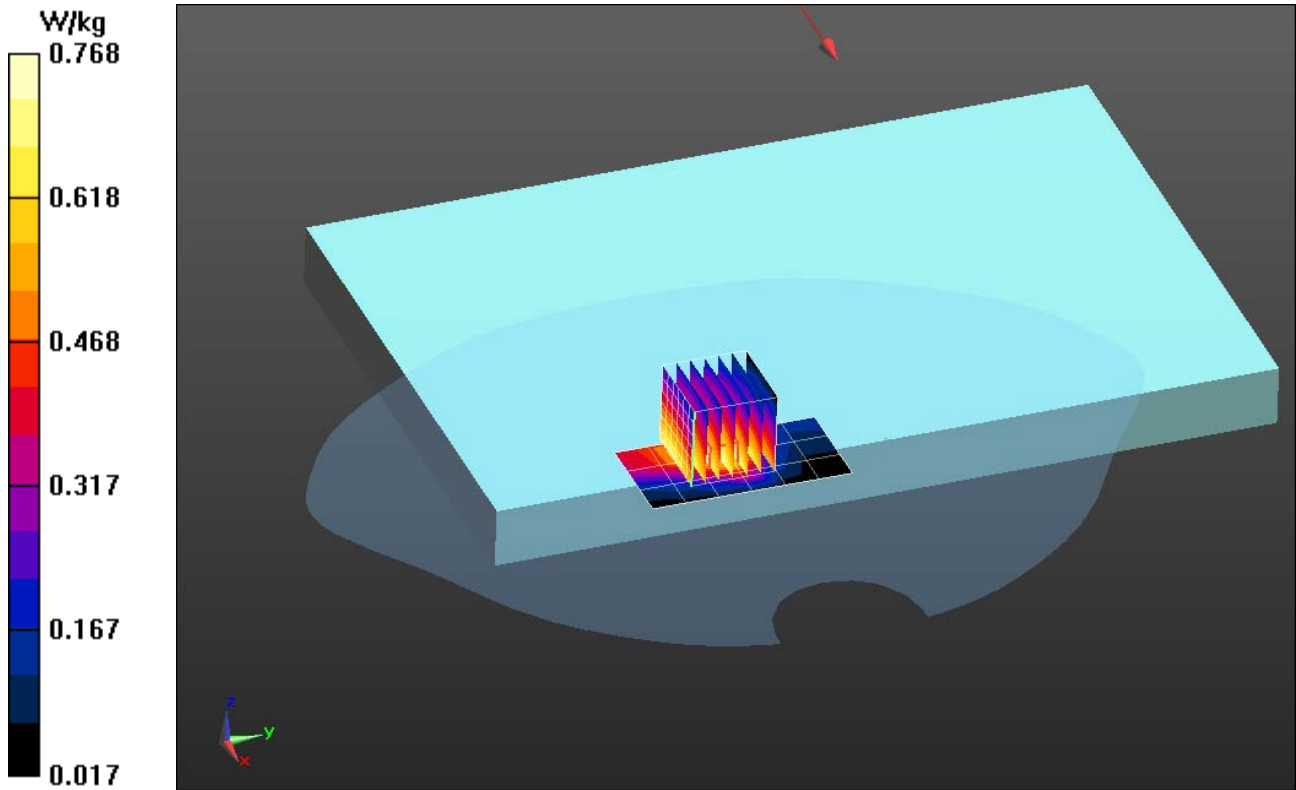

Plot A 2

Date/Time: 4/4/2013 10:19:00 AM

Test Laboratory: Intertek

File Name: [Tablet Edge 802.11b Scan.da52:4](#)**Tablet Edge 802.11b Scan**

Procedure Notes:

DUT: Xplore Tomcat ; Serial: SYS00B00010

Communication System: Generic 802.11b/g/n; Communication System Band: 2.4 GHz Band; Frequency: 2462 MHz; Duty Cycle: 1:1

Medium parameters used (interpolated): $f = 2462$ MHz; $\sigma = 2.022$ S/m; $\epsilon_r = 51.213$; $\rho = 1000$ kg/m³

Phantom section: Flat Section

Measurement Standard: DASYS5 (IEEE/IEC/ANSI C63.19-2007)

DASYS5 Configuration:

- Probe: EX3DV3 - SN3516; ConvF(7.92, 7.92, 7.92); Calibrated: 12/10/2012;
- Sensor-Surface: 2mm (Mechanical Surface Detection)
- Electronics: DAE4 Sn358; Calibrated: 9/11/2012
- Phantom: SAM 2 with CRP v5.0; Type: QD000P40CD; Serial: TP:1663
- DASYS52 52.8.5(1059); SEMCAD X 14.6.8(7028)

Wifi Flat-Section MSL Testing on 4_3_2013/Top Edge of Device Against Phantom, Data Rate =1mbps/Area Scan (4x7x1): Measurement grid: dx=12mm, dy=12mm

Maximum value of SAR (measured) = 0.377 W/kg

Wifi Flat-Section MSL Testing on 4_3_2013/Top Edge of Device Against Phantom, Data Rate =1mbps/Zoom Scan (7x7x7)/Cube 0: Measurement grid: dx=5mm, dy=5mm, dz=5mm

Reference Value = 8.447 V/m; Power Drift = -0.22 dB

Peak SAR (extrapolated) = 0.488 W/kg

SAR(1 g) = 0.265 W/kg

Maximum value of SAR (measured) = 0.369 W/kg

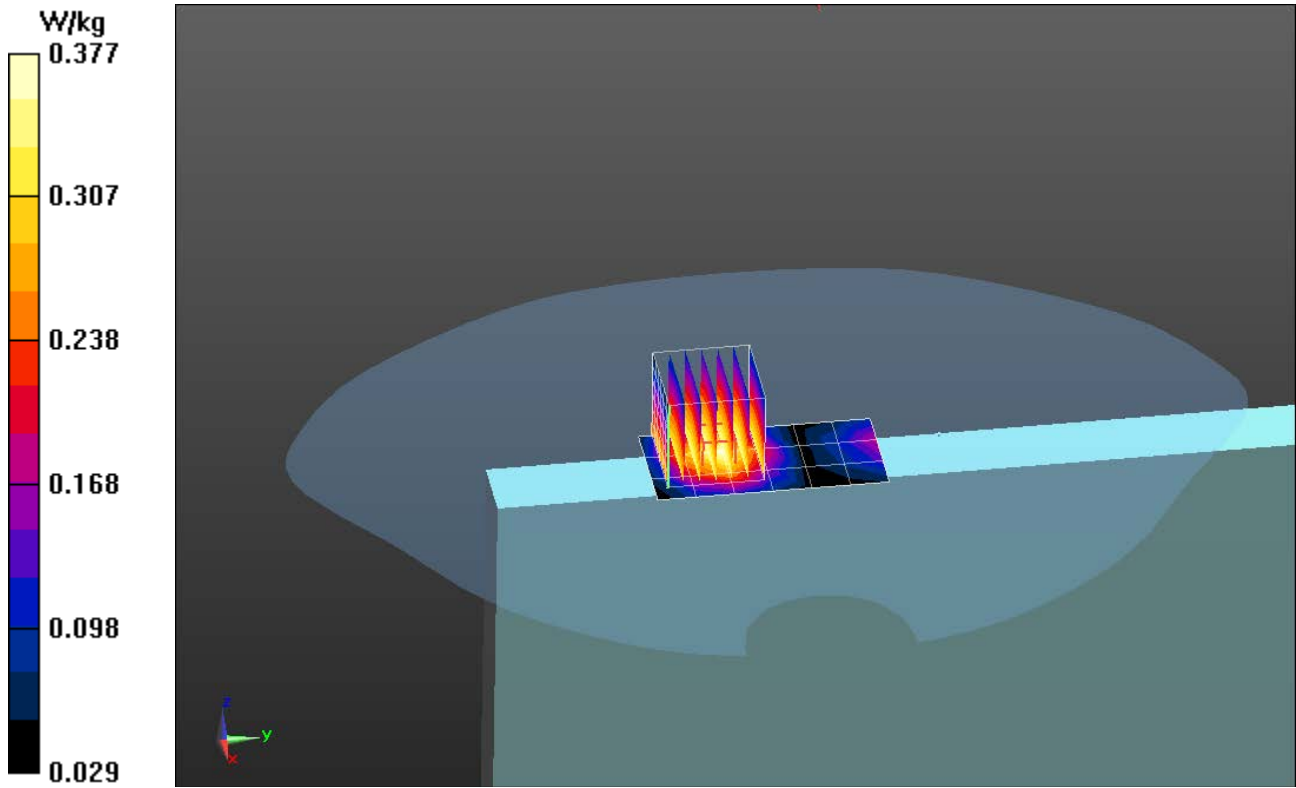

Plot A 3

Date/Time: 4/24/2013 3:40:20 PM

Test Laboratory: Intertek

Tablet Back Side 802.11a Scan**DUT: Xplore Tomcat ; Type: Tablet; Serial: SYS00B00010**

Communication System: Generic 802.11a; Communication System Band: UNII Band 1;
Frequency: 5200 MHz; Communication System PAR: 0 dB; PMF: 1.12202e-005
Medium parameters used: $f = 5200$ MHz; $\sigma = 5.3$ S/m; $\epsilon_r = 47.4$; $\rho = 1000$ kg/m³
Phantom section: Flat Section
Measurement Standard: DASYS (IEEE/IEC/ANSI C63.19-2007)

DASY Configuration:

- Probe: EX3DV3 - SN3516; ConvF(4.36, 4.36, 4.36); Calibrated: 12/10/2012;
 - Modulation Compensation:
- Sensor-Surface: 1.4mm (Mechanical Surface Detection), $z = 1.0, 25.0$
- Electronics: DAE4 Sn358; Calibrated: 9/11/2012
- Phantom: SAM 1 with CRP v5.0; Type: QD000P40CD; Serial: TP: 1243
- DASYS 52.8.5(1059); SEMCAD X 14.6.8(7028)

**Wifi Flat-Section MSL Testing on 4_20_2013/Back of Device Against Phantom,
Channel 40 Data Rate =6mbps/Area Scan (5x9x1):** Measurement grid: $dx=10$ mm,
 $dy=10$ mm

Maximum value of SAR (measured) = 0.635 W/kg

**Wifi Flat-Section MSL Testing on 4_20_2013/Back of Device Against Phantom,
Channel 40 Data Rate =6mbps/Zoom Scan (8x8x7)/Cube 0:** Measurement grid:
 $dx=4$ mm, $dy=4$ mm, $dz=1.4$ mm

Reference Value = 6.391 V/m; Power Drift = 0.01 dB

Peak SAR (extrapolated) = 1.21 W/kg

SAR(1 g) = 0.319 W/kg; SAR(10 g) = 0.091 W/kg

Maximum value of SAR (measured) = 0.749 W/kg

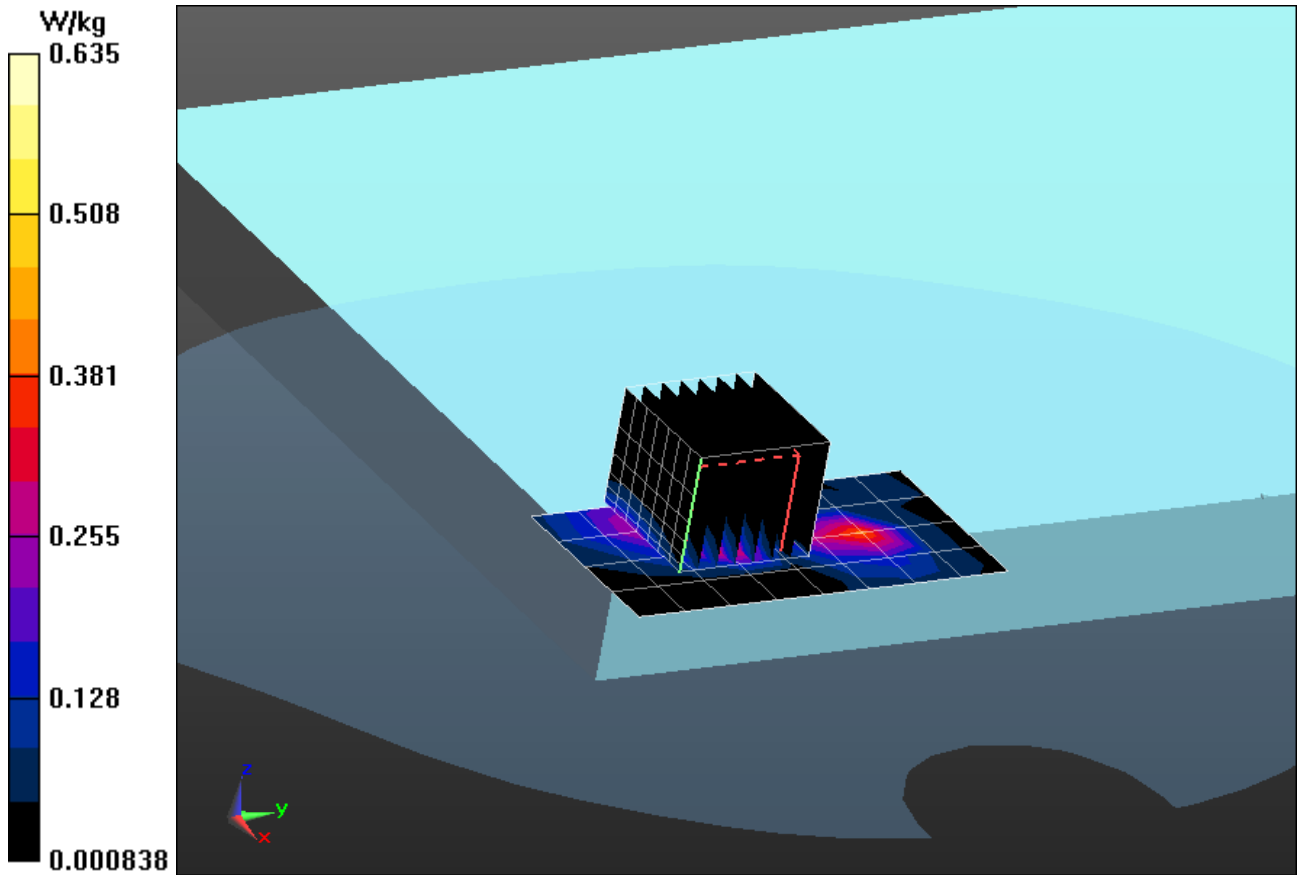

Plot A 4

Date/Time: 4/25/2013 9:02:42 AM

Test Laboratory: Intertek

Tablet Back Side 802.11a Scan**DUT: Xplore Tomcat ; Type: Tablet; Serial: SYS00B00010**

Communication System: Generic 802.11a; Communication System Band: UNII Band 2;
Frequency: 5300 MHz; Communication System PAR: 0 dB; PMF: 1.12202e-005
Medium parameters used: $f = 5300$ MHz; $\sigma = 5.595$ S/m; $\epsilon_r = 49.08$; $\rho = 1000$ kg/m³
Phantom section: Flat Section
Measurement Standard: DASYS (IEEE/IEC/ANSI C63.19-2007)

DASY Configuration:

- Probe: EX3DV3 - SN3516; ConvF(4.15, 4.15, 4.15); Calibrated: 12/10/2012;
 - Modulation Compensation:
- Sensor-Surface: 1.4mm (Mechanical Surface Detection), $z = 1.0, 25.0$
- Electronics: DAE4 Sn358; Calibrated: 9/11/2012
- Phantom: SAM 1 with CRP v5.0; Type: QD000P40CD; Serial: TP: 1243
- DASYS 52.8.5(1059); SEMCAD X 14.6.8(7028)

**Wifi Flat-Section MSL Testing on 4_20_2013/Back of Device Against Phantom,
Channel 60 Data Rate =6mbps/Area Scan (5x9x1):** Measurement grid: dx=10mm,
dy=10mm

Maximum value of SAR (measured) = 0.691 W/kg

**Wifi Flat-Section MSL Testing on 4_20_2013/Back of Device Against Phantom,
Channel 60 Data Rate =6mbps/Zoom Scan (8x8x7)/Cube 0:** Measurement grid:

dx=4mm, dy=4mm, dz=1.4mm

Reference Value = 8.557 V/m; Power Drift = -0.13 dB

Peak SAR (extrapolated) = 1.80 W/kg

SAR(1 g) = 0.444 W/kg; SAR(10 g) = 0.128 W/kg

Maximum value of SAR (measured) = 1.06 W/kg

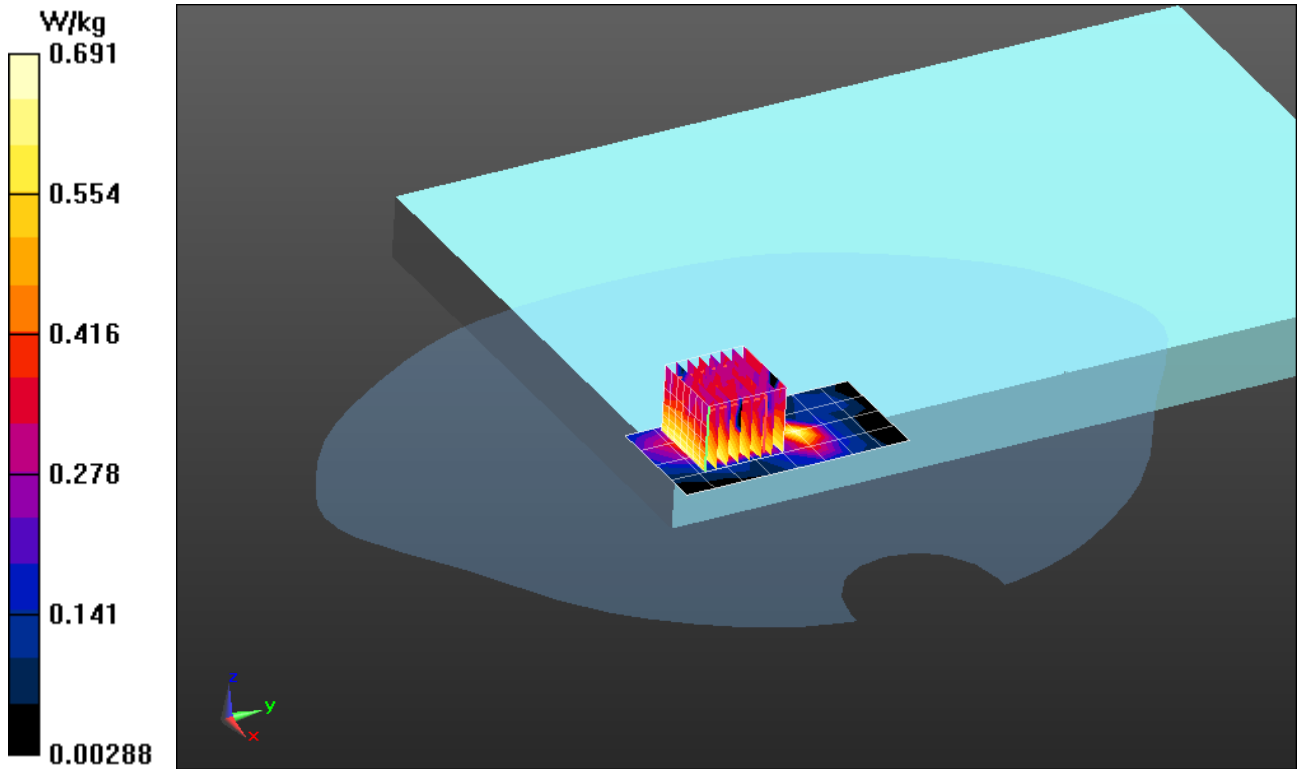

Plot A 5

Date/Time: 4/25/2013 10:15:55 AM

Test Laboratory: Intertek

Tablet Back Side 802.11a Scan**DUT: Xplore Tomcat ; Type: Tablet; Serial: SYS00B00010**

Communication System: Generic 802.11a; Communication System Band: UNII Band 3;
Frequency: 5580 MHz; Communication System PAR: 0 dB; PMF: 1.12202e-005
Medium parameters used: $f = 5580$ MHz; $\sigma = 5.972$ S/m; $\epsilon_r = 48.61$; $\rho = 1000$ kg/m³
Phantom section: Flat Section
Measurement Standard: DASYS (IEEE/IEC/ANSI C63.19-2007)

DASY Configuration:

- Probe: EX3DV3 - SN3516; ConvF(3.74, 3.74, 3.74); Calibrated: 12/10/2012;
 - Modulation Compensation:
- Sensor-Surface: 1.4mm (Mechanical Surface Detection), $z = 1.0, 25.0$
- Electronics: DAE4 Sn358; Calibrated: 9/11/2012
- Phantom: SAM 1 with CRP v5.0; Type: QD000P40CD; Serial: TP: 1243
- DASYS 52.8.5(1059); SEMCAD X 14.6.8(7028)

**Wifi Flat-Section MSL Testing on 4_20_2013/Back of Device Against Phantom,
Channel 116 Data Rate =6mbps/Area Scan (5x9x1):** Measurement grid: dx=10mm,
dy=10mm

Maximum value of SAR (measured) = 1.12 W/kg

**Wifi Flat-Section MSL Testing on 4_20_2013/Back of Device Against Phantom,
Channel 116 Data Rate =6mbps/Zoom Scan (8x8x7)/Cube 0:** Measurement grid:

dx=4mm, dy=4mm, dz=1.4mm

Reference Value = 9.182 V/m; Power Drift = 0.07 dB

Peak SAR (extrapolated) = 1.99 W/kg

SAR(1 g) = 0.482 W/kg; SAR(10 g) = 0.157 W/kg

Maximum value of SAR (measured) = 1.16 W/kg

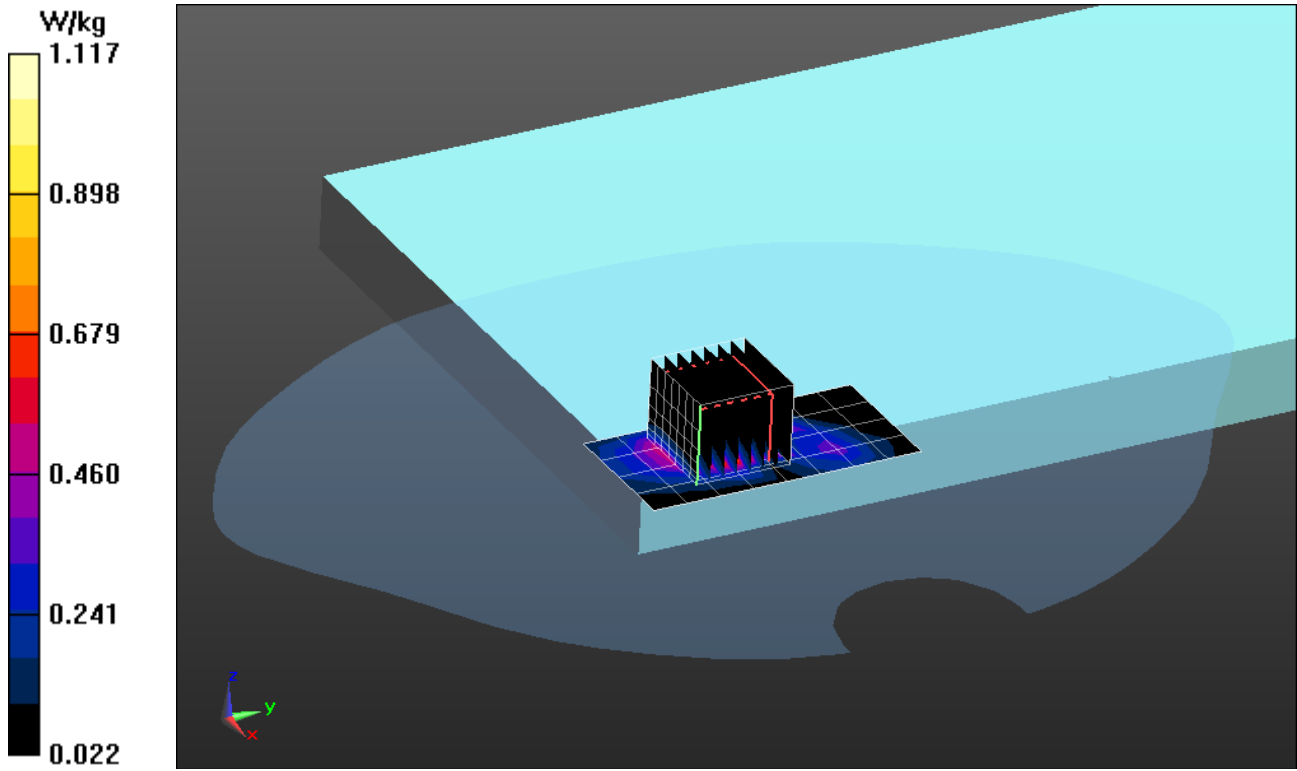

Plot A 6

Date/Time: 4/25/2013 10:50:59 AM

Test Laboratory: Intertek

Tablet Back Side 802.11a Scan

DUT: Xplore Tomcat ; Type: Tablet; Serial: SYS00B00010

Communication System: Generic 802.11a; Communication System Band: UNII Band 4;
Frequency: 5805 MHz; Communication System PAR: 0 dB; PMF: 1.12202e-005
Medium parameters used: $f = 5800$ MHz; $\sigma = 6.294$ S/m; $\epsilon_r = 48.23$; $\rho = 1000$ kg/m³
Phantom section: Flat Section
Measurement Standard: DASYS (IEEE/IEC/ANSI C63.19-2007)

DASY Configuration:

- Probe: EX3DV3 - SN3516; ConvF(3.95, 3.95, 3.95); Calibrated: 12/10/2012;
 - Modulation Compensation:
- Sensor-Surface: 1.4mm (Mechanical Surface Detection), $z = 1.0, 25.0$
- Electronics: DAE4 Sn358; Calibrated: 9/11/2012
- Phantom: SAM 1 with CRP v5.0; Type: QD000P40CD; Serial: TP: 1243
- DASYS 52.8.5(1059); SEMCAD X 14.6.8(7028)

Wifi Flat-Section MSL Testing on 4_20_2013/Back of Device Against Phantom, Channel 161 Data Rate =6mbps/Area Scan (5x9x1): Measurement grid: dx=10mm, dy=10mm

Maximum value of SAR (measured) = 0.847 W/kg

Wifi Flat-Section MSL Testing on 4_20_2013/Back of Device Against Phantom, Channel 161 Data Rate =6mbps/Zoom Scan (8x8x7)/Cube 0: Measurement grid:

dx=4mm, dy=4mm, dz=1.4mm

Reference Value = 4.999 V/m; Power Drift = 0.09 dB

Peak SAR (extrapolated) = 1.57 W/kg

SAR(1 g) = 0.358 W/kg; SAR(10 g) = 0.127 W/kg

Maximum value of SAR (measured) = 0.880 W/kg

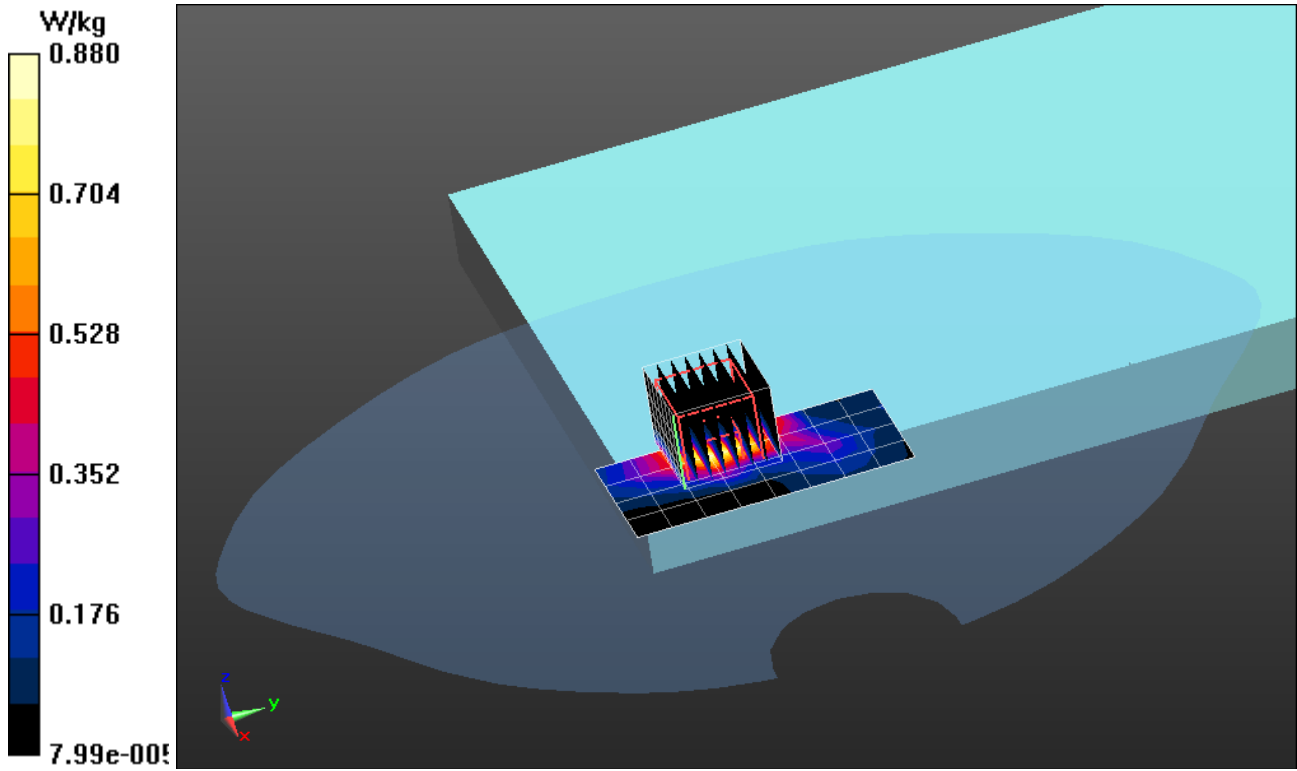

Plot A 7

Date/Time: 4/25/2013 1:22:31 PM

Test Laboratory: Intertek

Tablet Top Edge 802.11a Scan**DUT: Xplore Tomcat ; Type: Tablet; Serial: SYS00B00010**

Communication System: Generic 802.11a; Communication System Band: UNII Band 1;
Frequency: 5200 MHz; Communication System PAR: 0 dB; PMF: 1.12202e-005
Medium parameters used: $f = 5200$ MHz; $\sigma = 5.3$ S/m; $\epsilon_r = 47.4$; $\rho = 1000$ kg/m³
Phantom section: Flat Section
Measurement Standard: DASYS (IEEE/IEC/ANSI C63.19-2007)

DASY Configuration:

- Probe: EX3DV3 - SN3516; ConvF(4.36, 4.36, 4.36); Calibrated: 12/10/2012;
 - Modulation Compensation:
- Sensor-Surface: 1.4mm (Mechanical Surface Detection), $z = 1.0, 25.0$
- Electronics: DAE4 Sn358; Calibrated: 9/11/2012
- Phantom: SAM 1 with CRP v5.0; Type: QD000P40CD; Serial: TP: 1243
- DASYS 52.8.5(1059); SEMCAD X 14.6.8(7028)

**Wifi Flat-Section MSL Testing on 4_20_2013/Back of Device Against Phantom,
Channel 40 Data Rate =6mbps/Area Scan (5x17x1):** Measurement grid: dx=10mm,
dy=10mm

Maximum value of SAR (measured) = 1.16 W/kg

**Wifi Flat-Section MSL Testing on 4_20_2013/Back of Device Against Phantom,
Channel 40 Data Rate =6mbps/Zoom Scan (8x8x7)/Cube 0:** Measurement grid:

dx=4mm, dy=4mm, dz=1.4mm

Reference Value = 8.386 V/m; Power Drift = -0.01 dB

Peak SAR (extrapolated) = 1.75 W/kg

SAR(1 g) = 0.512 W/kg; SAR(10 g) = 0.175 W/kg

Maximum value of SAR (measured) = 1.13 W/kg

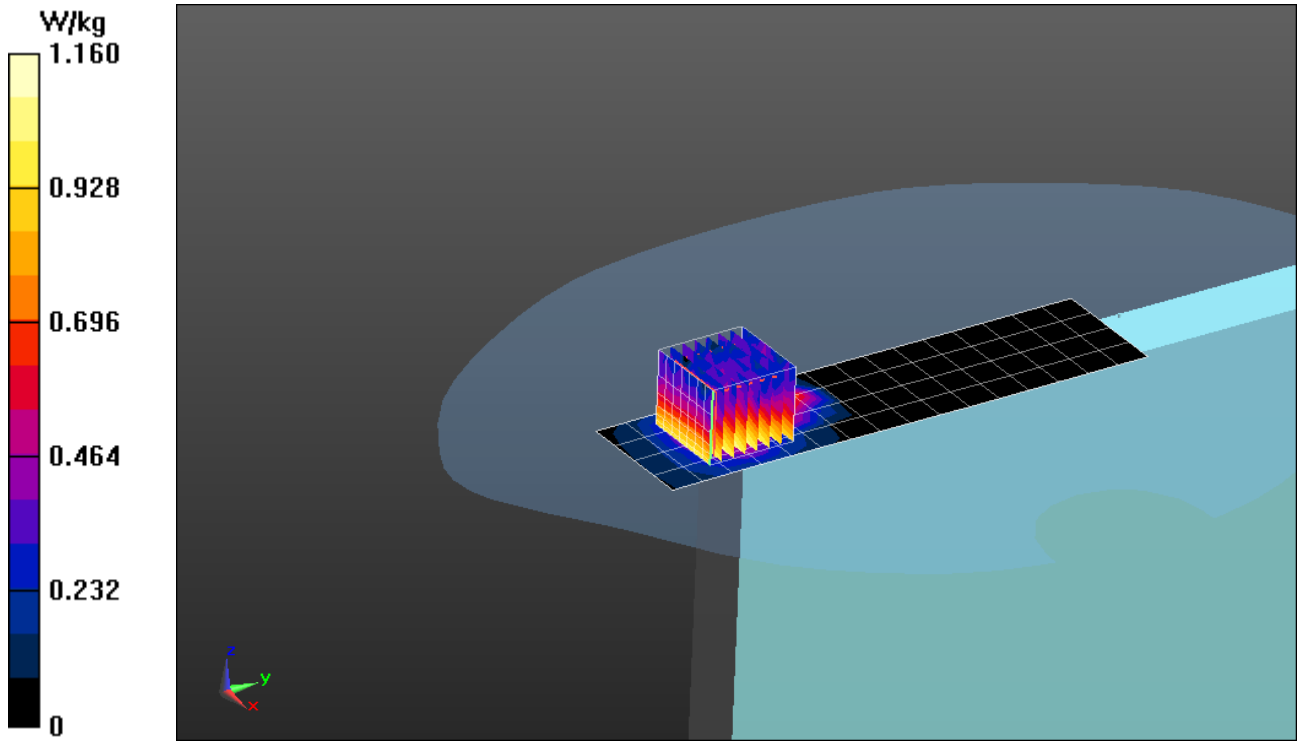

Plot A 8

Date/Time: 4/26/2013 8:52:01 AM

Test Laboratory: Intertek

File Name: [Tablet Top Edge 802.11a Scan.da52:4](#)**Tablet Top Edge 802.11a Scan**

Procedure Notes: Ambient Temp: Fluid Temp:

DUT: Xplore Tomcat ; Serial: SYS00B00010

Communication System: Generic 802.11a; Communication System Band: UNII Band 2; Frequency: 5300 MHz; Duty Cycle: 1:1

Medium parameters used: $f = 5300$ MHz; $\sigma = 5.595$ S/m; $\epsilon_r = 49.08$; $\rho = 1000$ kg/m³

Phantom section: Flat Section

Measurement Standard: DASYS (IEEE/IEC/ANSI C63.19-2007)

DASY5 Configuration:

- Probe: EX3DV3 - SN3516; ConvF(4.15, 4.15, 4.15); Calibrated: 12/10/2012;
- Sensor-Surface: 1.4mm (Mechanical Surface Detection)
- Electronics: DAE4 Sn358; Calibrated: 9/11/2012
- Phantom: SAM 1 with CRP v5.0; Type: QD000P40CD; Serial: TP: 1243
- DASYS 52.8.5(1059); SEMCAD X 14.6.8(7028)

Wifi Flat-Section MSL Testing on 4_20_2013/Back of Device Against Phantom, Channel 60 Data Rate =6mbps/Area Scan (5x9x1): Measurement grid: dx=10mm, dy=10mm
Maximum value of SAR (measured) = 1.19 W/kg**Wifi Flat-Section MSL Testing on 4_20_2013/Back of Device Against Phantom, Channel 60 Data Rate =6mbps/Zoom Scan (9x9x7)/Cube 0:** Measurement grid: dx=4mm, dy=4mm, dz=1.4mm
Reference Value = 9.108 V/m; Power Drift = -0.06 dB
Peak SAR (extrapolated) = 2.17 W/kg
SAR(1 g) = 0.591 W/kg; SAR(10 g) = 0.186 W/kg
Maximum value of SAR (measured) = 1.39 W/kg

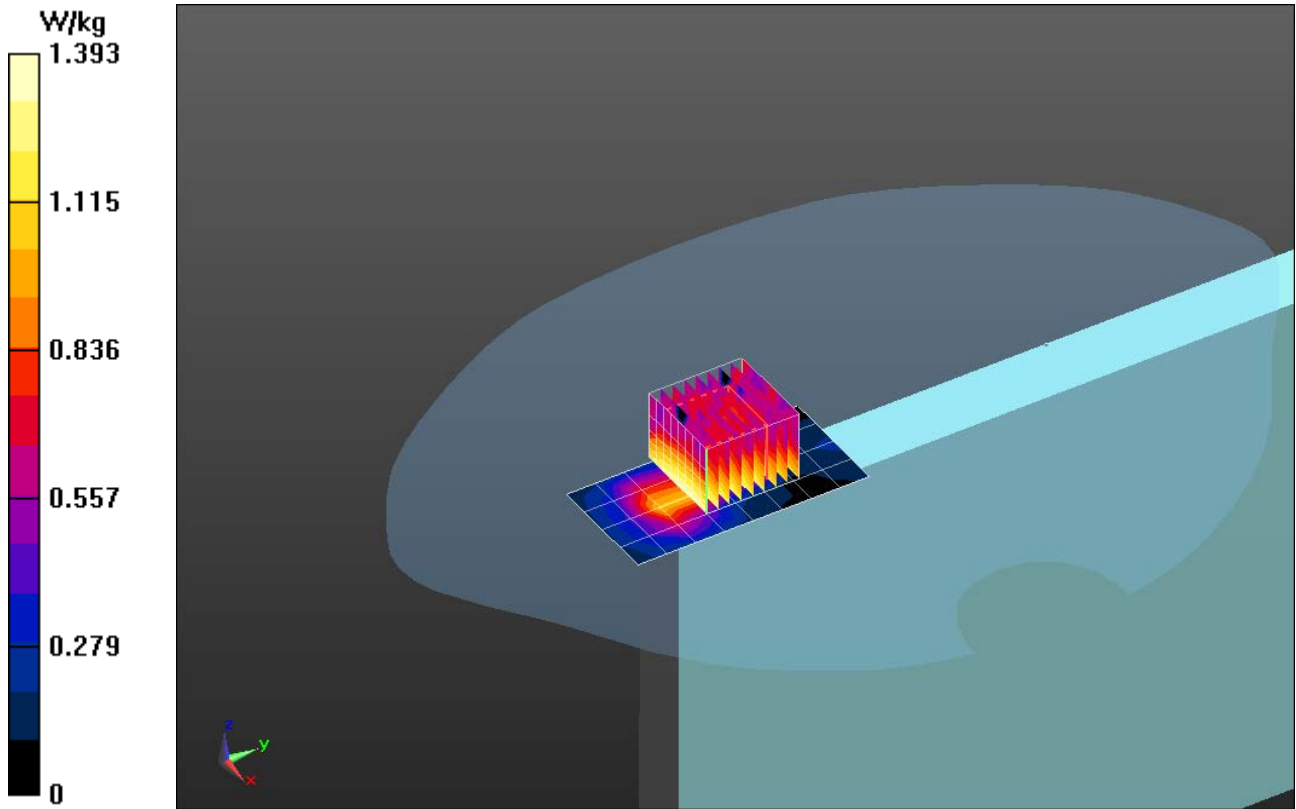

Plot A 9

Date/Time: 4/26/2013 9:56:58 AM

Test Laboratory: Intertek

Tablet Top Edge 802.11a Scan**DUT: Xplore Tomcat ; Type: Tablet; Serial: SYS00B00010**

Communication System: Generic 802.11a; Communication System Band: UNII Band 3;
Frequency: 5580 MHz; Communication System PAR: 0 dB; PMF: 1.12202e-005
Medium parameters used: $f = 5580$ MHz; $\sigma = 5.972$ S/m; $\epsilon_r = 48.61$; $\rho = 1000$ kg/m³
Phantom section: Flat Section
Measurement Standard: DASYS (IEEE/IEC/ANSI C63.19-2007)

DASY Configuration:

- Probe: EX3DV3 - SN3516; ConvF(3.74, 3.74, 3.74); Calibrated: 12/10/2012;
 - Modulation Compensation:
- Sensor-Surface: 1.4mm (Mechanical Surface Detection), $z = 1.0, 25.0$
- Electronics: DAE4 Sn358; Calibrated: 9/11/2012
- Phantom: SAM 1 with CRP v5.0; Type: QD000P40CD; Serial: TP: 1243
- DASYS 52.8.5(1059); SEMCAD X 14.6.8(7028)

**Wifi Flat-Section MSL Testing on 4_20_2013/Back of Device Against Phantom,
Channel 116 Data Rate =6mbps/Area Scan (5x9x1):** Measurement grid: dx=10mm,
dy=10mm

Maximum value of SAR (measured) = 1.82 W/kg

**Wifi Flat-Section MSL Testing on 4_20_2013/Back of Device Against Phantom,
Channel 116 Data Rate =6mbps/Zoom Scan (8x8x7)/Cube 0:** Measurement grid:

dx=4mm, dy=4mm, dz=1.4mm

Reference Value = 9.079 V/m; Power Drift = 0.05 dB

Peak SAR (extrapolated) = 2.72 W/kg

SAR(1 g) = 0.771 W/kg; SAR(10 g) = 0.264 W/kg

Maximum value of SAR (measured) = 1.74 W/kg

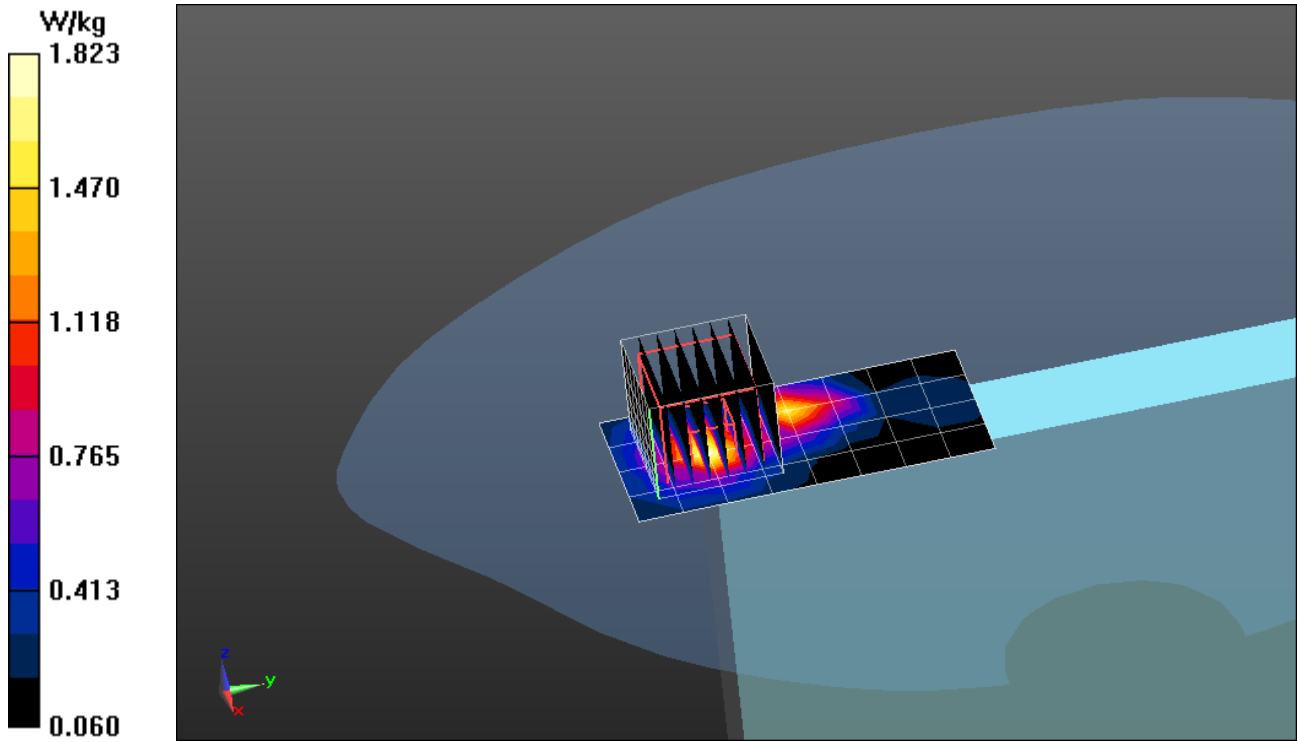

Plot A 10

Date/Time: 4/26/2013 11:03:15 AM

Test Laboratory: Intertek

Tablet Top Edge 802.11a Scan

DUT: Xplore Tomcat ; Type: Tablet; Serial: SYS00B00010

Communication System: Generic 802.11a; Communication System Band: UNII Band 4;
Frequency: 5805 MHz; Communication System PAR: 0 dB; PMF: 1.12202e-005
Medium parameters used: $f = 5800$ MHz; $\sigma = 6.294$ S/m; $\epsilon_r = 48.23$; $\rho = 1000$ kg/m³
Phantom section: Flat Section
Measurement Standard: DASYS (IEEE/IEC/ANSI C63.19-2007)

DASY Configuration:

- Probe: EX3DV3 - SN3516; ConvF(3.95, 3.95, 3.95); Calibrated: 12/10/2012;
 - Modulation Compensation:
- Sensor-Surface: 1.4mm (Mechanical Surface Detection), $z = 1.0, 25.0$
- Electronics: DAE4 Sn358; Calibrated: 9/11/2012
- Phantom: SAM 1 with CRP v5.0; Type: QD000P40CD; Serial: TP: 1243
- DASYS 52.8.5(1059); SEMCAD X 14.6.8(7028)

Wifi Flat-Section MSL Testing on 4_20_2013/Back of Device Against Phantom, Channel 161 Data Rate =6mbps/Area Scan (5x9x1): Measurement grid: dx=10mm, dy=10mm

Maximum value of SAR (measured) = 1.43 W/kg

Wifi Flat-Section MSL Testing on 4_20_2013/Back of Device Against Phantom, Channel 161 Data Rate =6mbps/Zoom Scan (8x8x7)/Cube 0: Measurement grid:

dx=4mm, dy=4mm, dz=1.4mm

Reference Value = 5.884 V/m; Power Drift = 0.09 dB

Peak SAR (extrapolated) = 2.84 W/kg

SAR(1 g) = 0.676 W/kg; SAR(10 g) = 0.218 W/kg

Maximum value of SAR (measured) = 1.60 W/kg

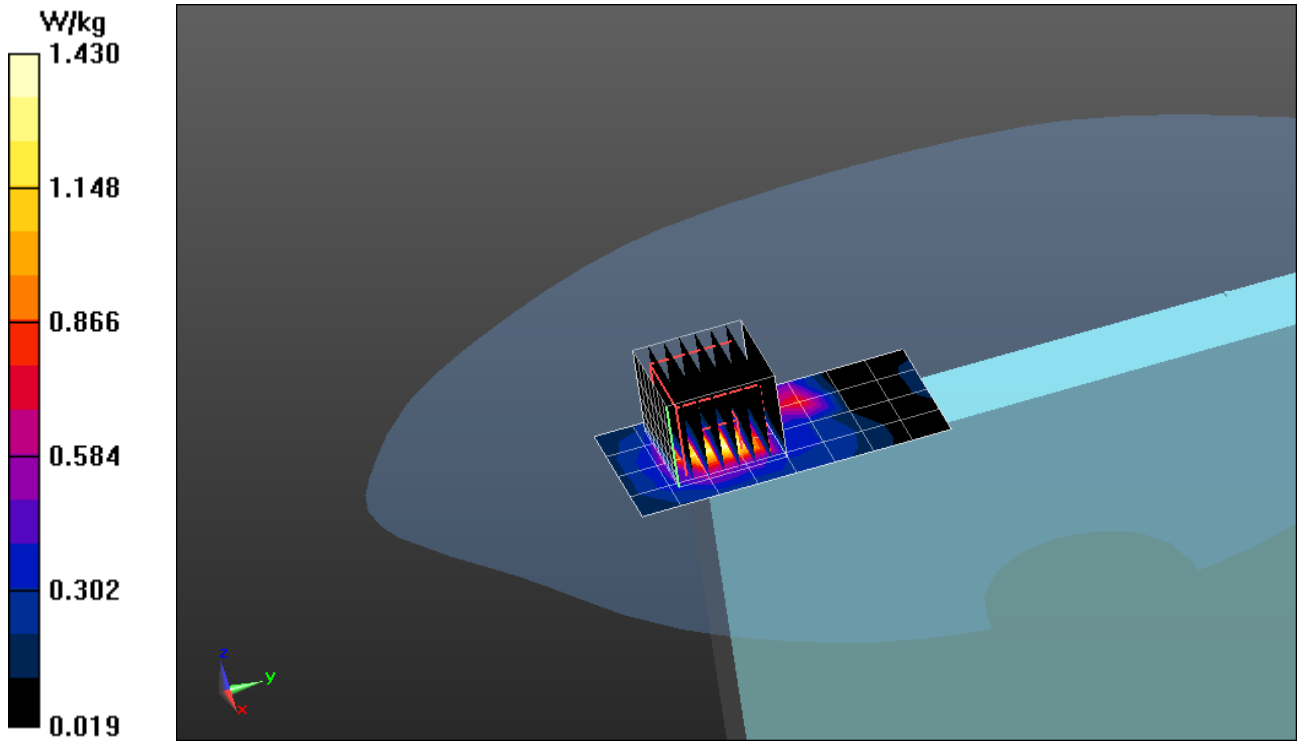

Plot A 11

Date/Time: 4/25/2013 3:15:56 PM

Test Laboratory: Intertek

Tablet Side Edge 802.11a Scan

DUT: Xplore Tomcat ; Type: Tablet; Serial: SYS00B00010

Communication System: Generic 802.11a; Communication System Band: UNII Band 1;
Frequency: 5200 MHz; Communication System PAR: 0 dB; PMF: 1.12202e-005
Medium parameters used: $f = 5200$ MHz; $\sigma = 5.3$ S/m; $\epsilon_r = 47.4$; $\rho = 1000$ kg/m³
Phantom section: Flat Section
Measurement Standard: DASY5 (IEEE/IEC/ANSI C63.19-2007)

DASY Configuration:

- Probe: EX3DV3 - SN3516; ConvF(4.36, 4.36, 4.36); Calibrated: 12/10/2012;
 - Modulation Compensation:
- Sensor-Surface: 1.4mm (Mechanical Surface Detection), $z = 1.0, 25.0$
- Electronics: DAE4 Sn358; Calibrated: 9/11/2012
- Phantom: SAM 1 with CRP v5.0; Type: QD000P40CD; Serial: TP: 1243
- DASY52 52.8.5(1059); SEMCAD X 14.6.8(7028)

Wifi Flat-Section MSL Testing on 4_20_2013/Back of Device Against Phantom, Channel 40 Data Rate =6mbps/Area Scan (6x9x1): Measurement grid: dx=10mm, dy=10mm

Maximum value of SAR (measured) = 0.228 W/kg

Wifi Flat-Section MSL Testing on 4_20_2013/Back of Device Against Phantom, Channel 40 Data Rate =6mbps/Zoom Scan (9x9x7)/Cube 0: Measurement grid:

dx=4mm, dy=4mm, dz=1.4mm

Reference Value = 4.308 V/m; Power Drift = 0.05 dB

Peak SAR (extrapolated) = 0.408 W/kg

SAR(1 g) = 0.117 W/kg; SAR(10 g) = 0.046 W/kg

Maximum value of SAR (measured) = 0.257 W/kg

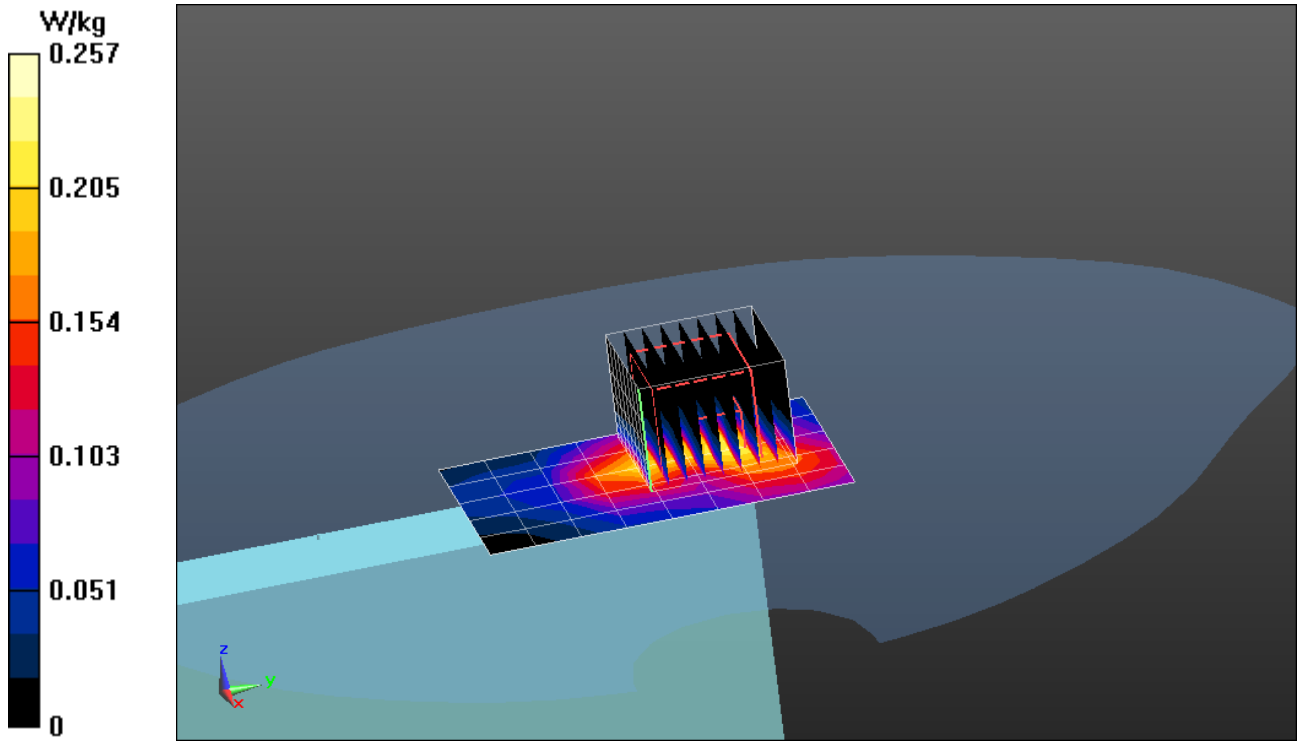

Plot A 12

Date/Time: 4/25/2013 4:40:37 PM

Test Laboratory: Intertek

File Name: [Tablet Side Edge 802.11a Scan.da52:4](#)**Tablet Side Edge 802.11a Scan**

Procedure Notes: Ambient Temp: Fluid Temp:

DUT: Xplore Tomcat ; Serial: SYS00B00010

Communication System: Generic 802.11a; Communication System Band: UNII Band 2; Frequency: 5300 MHz; Duty Cycle: 1:1

Medium parameters used: $f = 5300$ MHz; $\sigma = 5.595$ S/m; $\epsilon_r = 49.08$; $\rho = 1000$ kg/m³

Phantom section: Flat Section

Measurement Standard: DASYS (IEEE/IEC/ANSI C63.19-2007)

DASY5 Configuration:

- Probe: EX3DV3 - SN3516; ConvF(4.15, 4.15, 4.15); Calibrated: 12/10/2012;
- Sensor-Surface: 1.4mm (Mechanical Surface Detection)
- Electronics: DAE4 Sn358; Calibrated: 9/11/2012
- Phantom: SAM 1 with CRP v5.0; Type: QD000P40CD; Serial: TP: 1243
- DASYS 52.8.5(1059); SEMCAD X 14.6.8(7028)

Wifi Flat-Section MSL Testing on 4_20_2013/Back of Device Against Phantom, Channel 60 Data Rate =6mbps/Area Scan (6x9x1): Measurement grid: dx=10mm, dy=10mm
Maximum value of SAR (measured) = 0.293 W/kg**Wifi Flat-Section MSL Testing on 4_20_2013/Back of Device Against Phantom, Channel 60 Data Rate =6mbps/Zoom Scan (8x8x7)/Cube 0:** Measurement grid: dx=4mm, dy=4mm, dz=1.4mm
Reference Value = 4.926 V/m; Power Drift = 0.07 dB
Peak SAR (extrapolated) = 0.516 W/kg
SAR(1 g) = 0.146 W/kg; SAR(10 g) = 0.056 W/kg
Maximum value of SAR (measured) = 0.319 W/kg

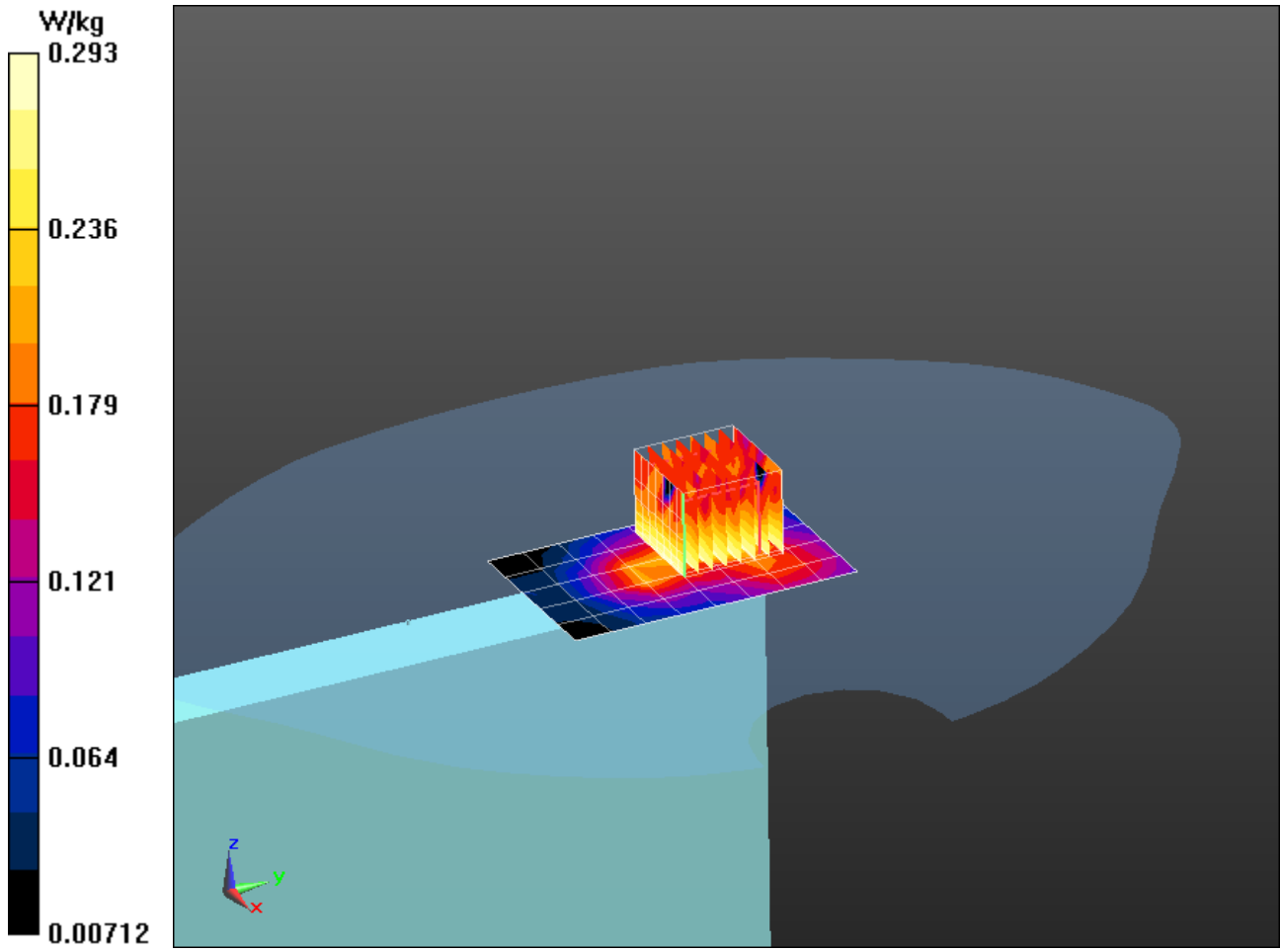

Plot A 13

Date/Time: 4/26/2013 4:33:09 PM

Test Laboratory: Intertek

Tablet Side Edge 802.11a Scan**DUT: Xplore Tomcat ; Type: Tablet; Serial: SYS00B00010**

Communication System: Generic 802.11a; Communication System Band: UNII Band 3;
Frequency: 5580 MHz; Communication System PAR: 0 dB; PMF: 1.12202e-005
Medium parameters used: $f = 5580$ MHz; $\sigma = 5.972$ S/m; $\epsilon_r = 48.61$; $\rho = 1000$ kg/m³
Phantom section: Flat Section
Measurement Standard: DASYS (IEEE/IEC/ANSI C63.19-2007)

DASY Configuration:

- Probe: EX3DV3 - SN3516; ConvF(3.74, 3.74, 3.74); Calibrated: 12/10/2012;
 - Modulation Compensation:
- Sensor-Surface: 1.4mm (Mechanical Surface Detection), $z = 1.0, 25.0$
- Electronics: DAE4 Sn358; Calibrated: 9/11/2012
- Phantom: SAM 1 with CRP v5.0; Type: QD000P40CD; Serial: TP: 1243
- DASYS 52.8.5(1059); SEMCAD X 14.6.8(7028)

**Wifi Flat-Section MSL Testing on 4_20_2013/Back of Device Against Phantom,
Channel 116 Data Rate =6mbps/Area Scan (6x9x1):** Measurement grid: dx=10mm,
dy=10mm

Maximum value of SAR (measured) = 0.453 W/kg

**Wifi Flat-Section MSL Testing on 4_20_2013/Back of Device Against Phantom,
Channel 116 Data Rate =6mbps/Zoom Scan (8x8x7)/Cube 0:** Measurement grid:
dx=4mm, dy=4mm, dz=1.4mm

Reference Value = 4.362 V/m; Power Drift = 0.10 dB

Peak SAR (extrapolated) = 0.832 W/kg

SAR(1 g) = 0.197 W/kg; SAR(10 g) = 0.074 W/kg

Maximum value of SAR (measured) = 0.463 W/kg

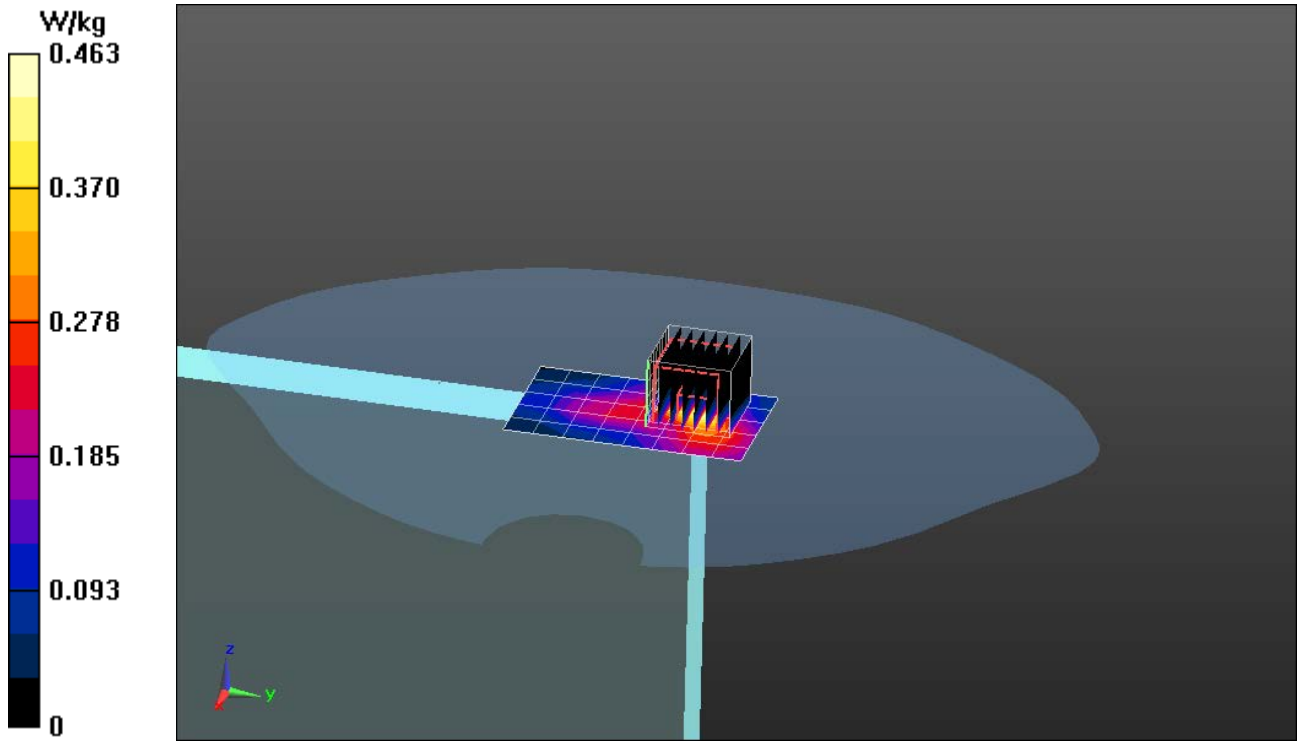

Plot A 14

Date/Time: 4/26/2013 12:03:33 PM

Test Laboratory: Intertek

Tablet Side Edge 802.11a Scan**DUT: Xplore Tomcat ; Type: Tablet; Serial: SYS00B00010**

Communication System: Generic 802.11a; Communication System Band: UNII Band 4;
Frequency: 5805 MHz; Communication System PAR: 0 dB; PMF: 1.12202e-005
Medium parameters used: $f = 5800$ MHz; $\sigma = 6.294$ S/m; $\epsilon_r = 48.23$; $\rho = 1000$ kg/m³
Phantom section: Flat Section
Measurement Standard: DASYS (IEEE/IEC/ANSI C63.19-2007)

DASY Configuration:

- Probe: EX3DV3 - SN3516; ConvF(3.95, 3.95, 3.95); Calibrated: 12/10/2012;
 - Modulation Compensation:
- Sensor-Surface: 1.4mm (Mechanical Surface Detection), $z = 1.0, 25.0$
- Electronics: DAE4 Sn358; Calibrated: 9/11/2012
- Phantom: SAM 1 with CRP v5.0; Type: QD000P40CD; Serial: TP: 1243
- DASYS 52.8.5(1059); SEMCAD X 14.6.8(7028)

**Wifi Flat-Section MSL Testing on 4_20_2013/Back of Device Against Phantom,
Channel 161 Data Rate =6mbps/Area Scan (6x9x1):** Measurement grid: dx=10mm,
dy=10mm

Maximum value of SAR (measured) = 0.405 W/kg

**Wifi Flat-Section MSL Testing on 4_20_2013/Back of Device Against Phantom,
Channel 161 Data Rate =6mbps/Zoom Scan (9x9x7)/Cube 0:** Measurement grid:
dx=4mm, dy=4mm, dz=1.4mm

Reference Value = 4.557 V/m; Power Drift = 0.16 dB

Peak SAR (extrapolated) = 0.849 W/kg

SAR(1 g) = 0.202 W/kg; SAR(10 g) = 0.075 W/kg

Maximum value of SAR (measured) = 0.488 W/kg

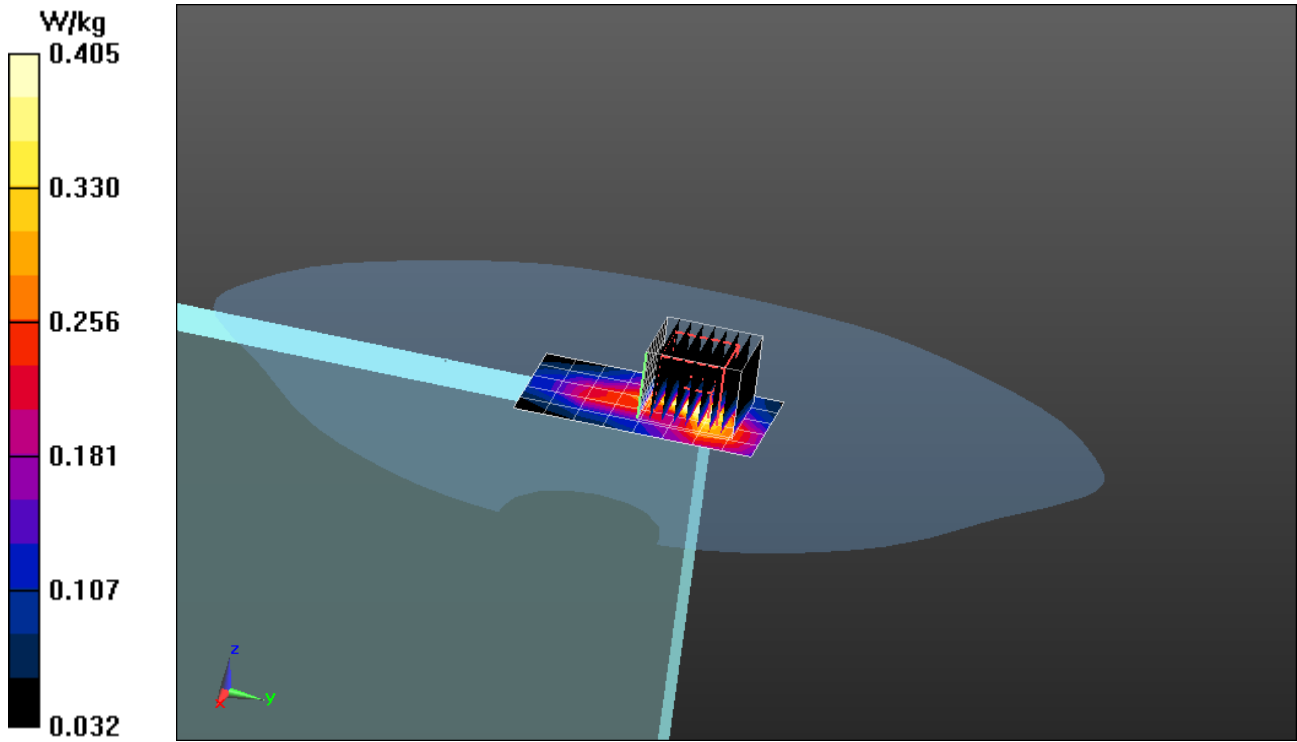

12.0 APPENDIX B – SYSTEM VERIFICATION PLOTS*Plot B 1*

Date/Time: 4/3/2013 2:46:35 PM

Test Laboratory: Intertek

2.4GHz Dipole Validation 4_3_13**DUT: Dipole 2450 MHz D2450V2; Type: D2450V2; Serial: D2450V2 - SN:xxx**

Communication System: CW; Communication System Band: D2450 (2450.0 MHz); Frequency: 2450 MHz; Communication System PAR: 0 dB; PMF: 1

Medium parameters used: $f = 2450$ MHz; $\sigma = 1.998$ S/m; $\epsilon_r = 51.332$; $\rho = 1000$ kg/m³

Phantom section: Flat Section

Measurement Standard: DASYS (IEEE/IEC/ANSI C63.19-2007)

DASY Configuration:

- Probe: EX3DV3 - SN3516; ConvF(7.92, 7.92, 7.92); Calibrated: 12/10/2012;
 - Modulation Compensation:
- Sensor-Surface: 2mm (Mechanical Surface Detection), Sensor-Surface: 4mm (Mechanical Surface Detection), $z = 1.0, 31.0$
- Electronics: DAE4 Sn358; Calibrated: 9/11/2012
- Phantom: SAM 2 with CRP v5.0; Type: QD000P40CD; Serial: TP:1663
- DASYS2 52.8.5(1059); SEMCAD X 14.6.8(7028)

System Performance Check at Frequencies above 1 GHz/d=10mm, Pin=100 mW with 10db attenuator at dipole, dist=2.0mm (EX-Probe)/Area Scan (4x7x1):

Measurement grid: dx=15mm, dy=15mm

Maximum value of SAR (measured) = 8.01 W/kg

System Performance Check at Frequencies above 1 GHz/d=10mm, Pin=100 mW with 10db attenuator at dipole, dist=2.0mm (EX-Probe)/Zoom Scan (7x7x7)**(7x7x7)/Cube 0:** Measurement grid: dx=5mm, dy=5mm, dz=5mm

Reference Value = 62.186 V/m; Power Drift = -0.03 dB

Peak SAR (extrapolated) = 110 W/kg

SAR(1 g) = 53.8 W/kg; SAR(10 g) = 24.7 W/kg

Normalized to target power = 1 W and actual power = 0.1 W

Maximum value of SAR (measured) = 61.7 W/kg

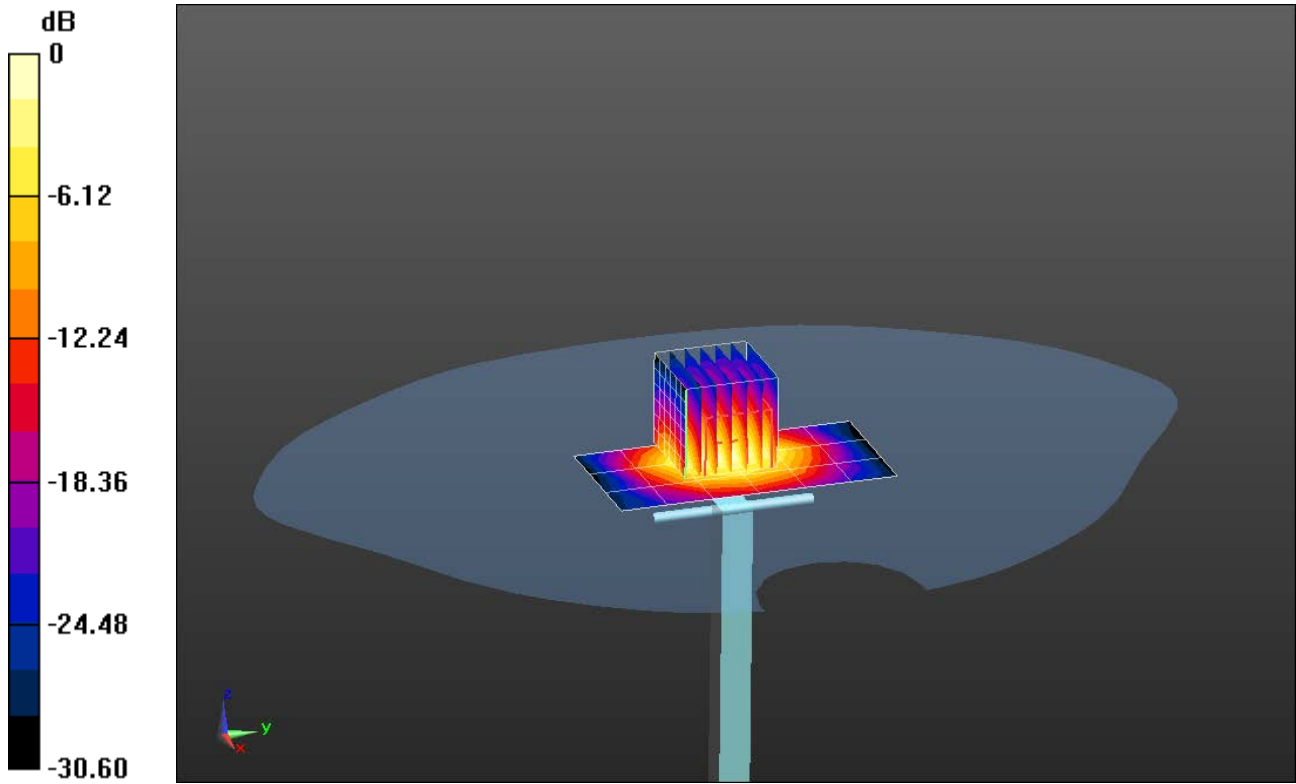

0 dB = 8.01 W/kg = 9.04 dBW/kg

Plot B 2

Date/Time: 4/4/2013 8:48:00 AM

Test Laboratory: Intertek

2.4GHz Dipole Validation 4_4_13

DUT: Dipole 2450 MHz D2450V2; Type: D2450V2; Serial: D2450V2 - SN:xxx

Communication System: CW; Communication System Band: D2450 (2450.0 MHz); Frequency: 2450 MHz; Communication System PAR: 0 dB; PMF: 1

Medium parameters used: $f = 2450$ MHz; $\sigma = 1.998$ S/m; $\epsilon_r = 51.332$; $\rho = 1000$ kg/m³

Phantom section: Flat Section

Measurement Standard: DASYS (IEEE/IEC/ANSI C63.19-2007)

DASY Configuration:

- Probe: EX3DV3 - SN3516; ConvF(7.92, 7.92, 7.92); Calibrated: 12/10/2012;
 - Modulation Compensation:
- Sensor-Surface: 2mm (Mechanical Surface Detection), Sensor-Surface: 4mm (Mechanical Surface Detection), $z = 1.0, 31.0$
- Electronics: DAE4 Sn358; Calibrated: 9/11/2012
- Phantom: SAM 2 with CRP v5.0; Type: QD000P40CD; Serial: TP:1663
- DASYS2 52.8.5(1059); SEMCAD X 14.6.8(7028)

System Performance Check at Frequencies above 1 GHz/d=10mm, Pin=100 mW with 10db attenuator at dipole, dist=2.0mm (EX-Probe)/Area Scan (4x7x1):

Measurement grid: dx=15mm, dy=15mm

Maximum value of SAR (measured) = 5.48 W/kg

System Performance Check at Frequencies above 1 GHz/d=10mm, Pin=100 mW with 10db attenuator at dipole, dist=2.0mm (EX-Probe)/Zoom Scan (7x7x7)

(7x7x7)/Cube 0: Measurement grid: dx=5mm, dy=5mm, dz=5mm

Reference Value = 62.908 V/m; Power Drift = -0.05 dB

Peak SAR (extrapolated) = 104 W/kg

SAR(1 g) = 50.6 W/kg; SAR(10 g) = 23.3 W/kg

Normalized to target power = 1 W and actual power = 0.1 W

Maximum value of SAR (measured) = 57.9 W/kg

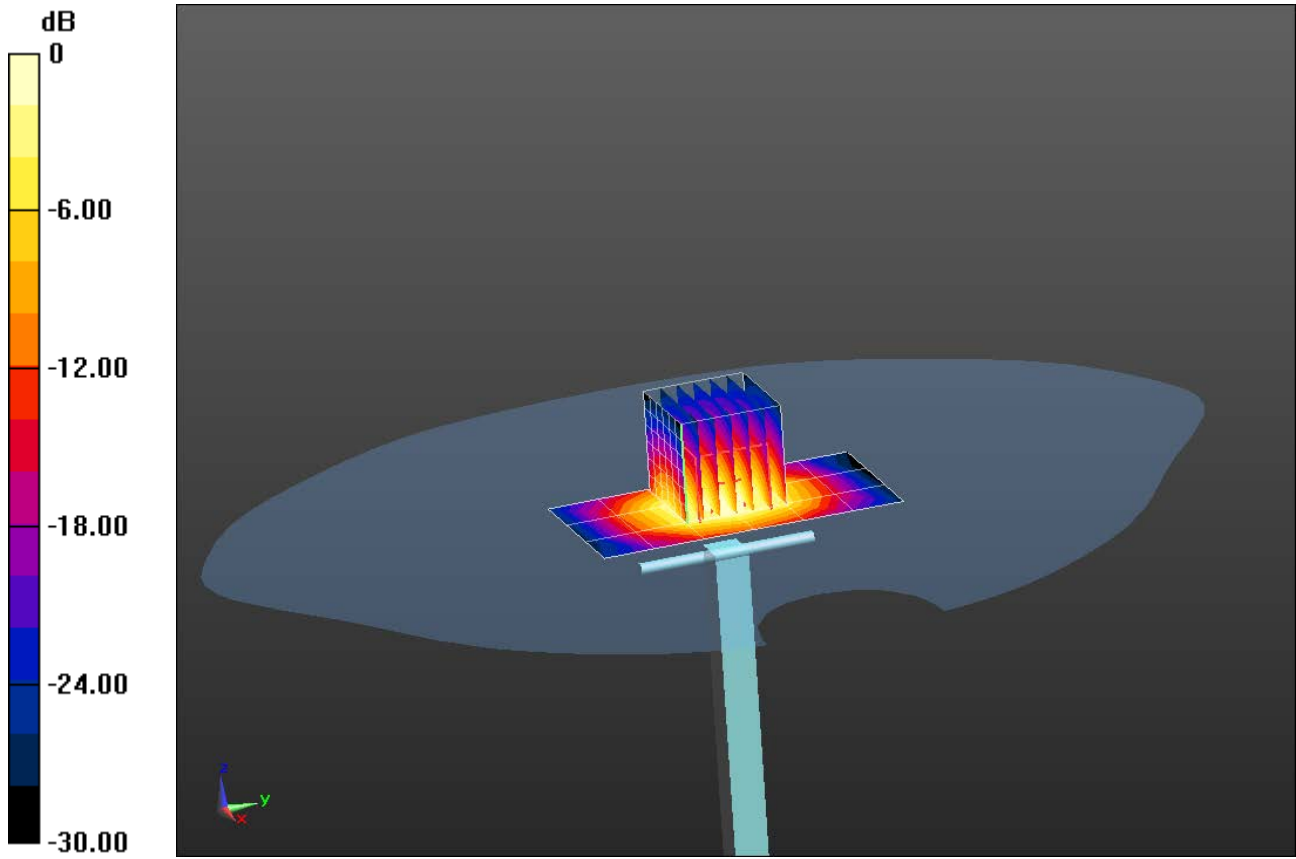

0 dB = 5.48 W/kg = 7.39 dBW/kg

Plot B 3

Date/Time: 4/24/2013 2:46:18 PM

Test Laboratory: Intertek

5GHz Dipole Validation 4_24_13**DUT: Dipole D5GHzV2; Type: D5GHzV2; Serial: D5GHzV2 - SN:xxx**

Communication System: CW; Communication System Band: D5GHz (5000.0 - 6000.0 MHz);
Frequency: 5200 MHz; Communication System PAR: 0 dB; PMF: 1
Medium parameters used: $f = 5200$ MHz; $\sigma = 5.3$ S/m; $\epsilon_r = 47.4$; $\rho = 1000$ kg/m³
Phantom section: Flat Section
Measurement Standard: DASYS (IEEE/IEC/ANSI C63.19-2007)

DASY Configuration:

- Probe: EX3DV3 - SN3516; ConvF(4.36, 4.36, 4.36); Calibrated: 12/10/2012;
 - Modulation Compensation:
- Sensor-Surface: 1.4mm (Mechanical Surface Detection), $z = 1.0, 25.0$
- Electronics: DAE4 Sn358; Calibrated: 9/11/2012
- Phantom: SAM 1 with CRP v5.0; Type: QD000P40CD; Serial: TP: 1243
- DASYS 52.8.5(1059); SEMCAD X 14.6.8(7028)

**System Performance Check with D5GHzV2 Dipole (graded grid)/d=10mm,
Pin=100mW, f=5200 MHz/Area Scan (6x6x1):** Measurement grid: dx=10mm, dy=10mm
Maximum value of SAR (measured) = 1.59 W/kg

**System Performance Check with D5GHzV2 Dipole (graded grid)/d=10mm,
Pin=100mW, f=5200 MHz/Zoom Scan (4x4x1.4mm, graded), dist=1.4mm
(8x8x7)/Cube 0:** Measurement grid: dx=4mm, dy=4mm, dz=1.4mm
Reference Value = 17.139 V/m; Power Drift = 0.08 dB
Peak SAR (extrapolated) = 272 W/kg
SAR(1 g) = 71.7 W/kg; SAR(10 g) = 20.1 W/kg
Normalized to target power = 1 W and actual power = 0.01 W
Maximum value of SAR (measured) = 163 W/kg

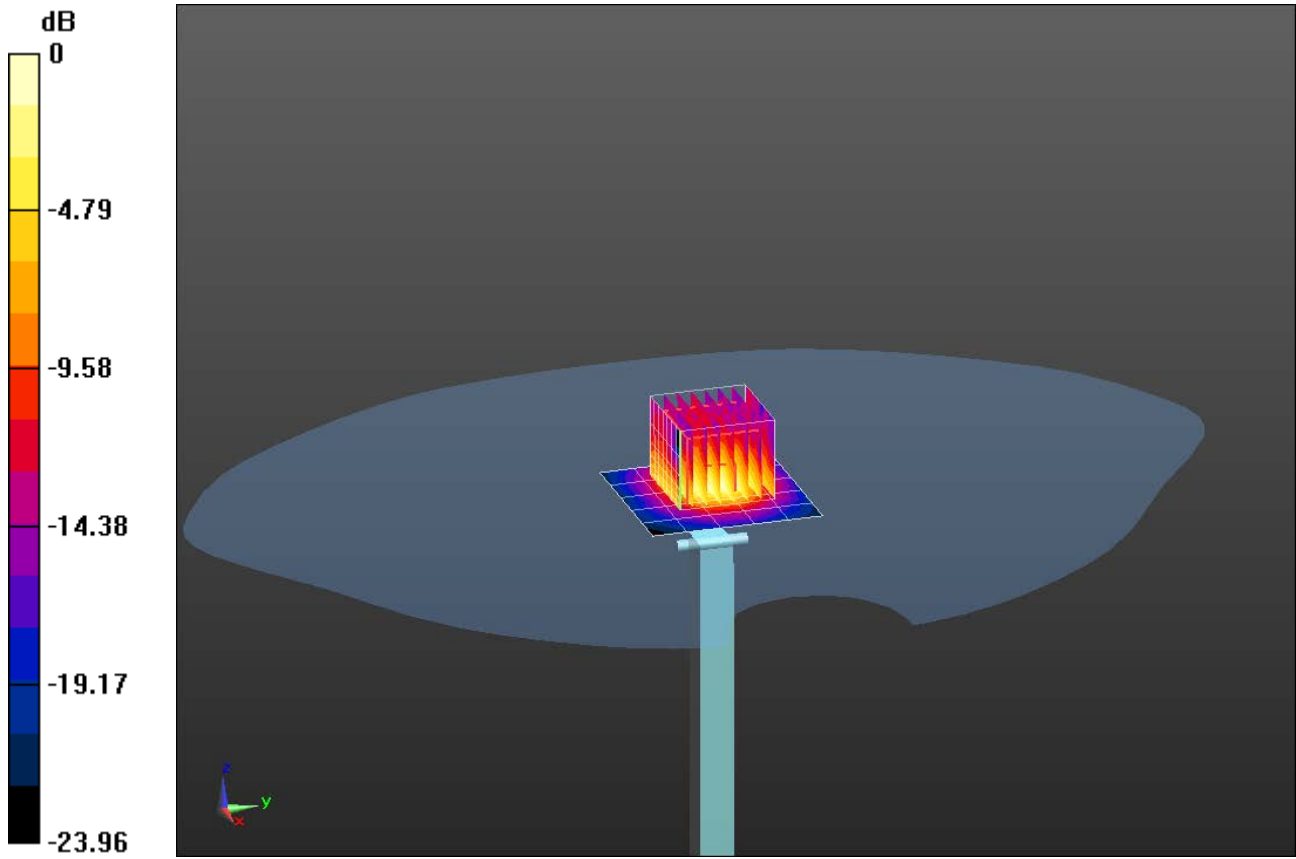

0 dB = 1.59 W/kg = 2.01 dBW/kg

Plot B 4

Date/Time: 4/24/2013 2:02:38 PM

Test Laboratory: Intertek

5GHz Dipole Validation 4_24_13

DUT: Dipole D5GHzV2; Type: D5GHzV2; Serial: D5GHzV2 - SN:xxx

Communication System: CW; Communication System Band: D5GHz (5000.0 - 6000.0 MHz);
Frequency: 5500 MHz; Communication System PAR: 0 dB; PMF: 1
Medium parameters used: $f = 5500$ MHz; $\sigma = 5.68$ S/m; $\epsilon_r = 46.7$; $\rho = 1000$ kg/m³
Phantom section: Flat Section
Measurement Standard: DASYS (IEEE/IEC/ANSI C63.19-2007)

DASY Configuration:

- Probe: EX3DV3 - SN3516; ConvF(3.94, 3.94, 3.94); Calibrated: 12/10/2012;
 - Modulation Compensation:
- Sensor-Surface: 1.4mm (Mechanical Surface Detection), $z = 1.0, 25.0$
- Electronics: DAE4 Sn358; Calibrated: 9/11/2012
- Phantom: SAM 1 with CRP v5.0; Type: QD000P40CD; Serial: TP: 1243
- DASYS 52.8.5(1059); SEMCAD X 14.6.8(7028)

System Performance Check with D5GHzV2 Dipole (graded grid)/d=10mm, Pin=100mW, f=5500 MHz/Area Scan (6x6x1): Measurement grid: dx=10mm, dy=10mm
Maximum value of SAR (measured) = 1.76 W/kg

System Performance Check with D5GHzV2 Dipole (graded grid)/d=10mm, Pin=100mW, f=5500 MHz/Zoom Scan (4x4x1.4mm, graded), dist=1.4mm (8x8x7)/Cube 0: Measurement grid: dx=4mm, dy=4mm, dz=1.4mm
Reference Value = 17.316 V/m; Power Drift = 0.18 dB
Peak SAR (extrapolated) = 317 W/kg
SAR(1 g) = 76.5 W/kg; SAR(10 g) = 21.2 W/kg
Normalized to target power = 1 W and actual power = 0.01 W
Maximum value of SAR (measured) = 180 W/kg

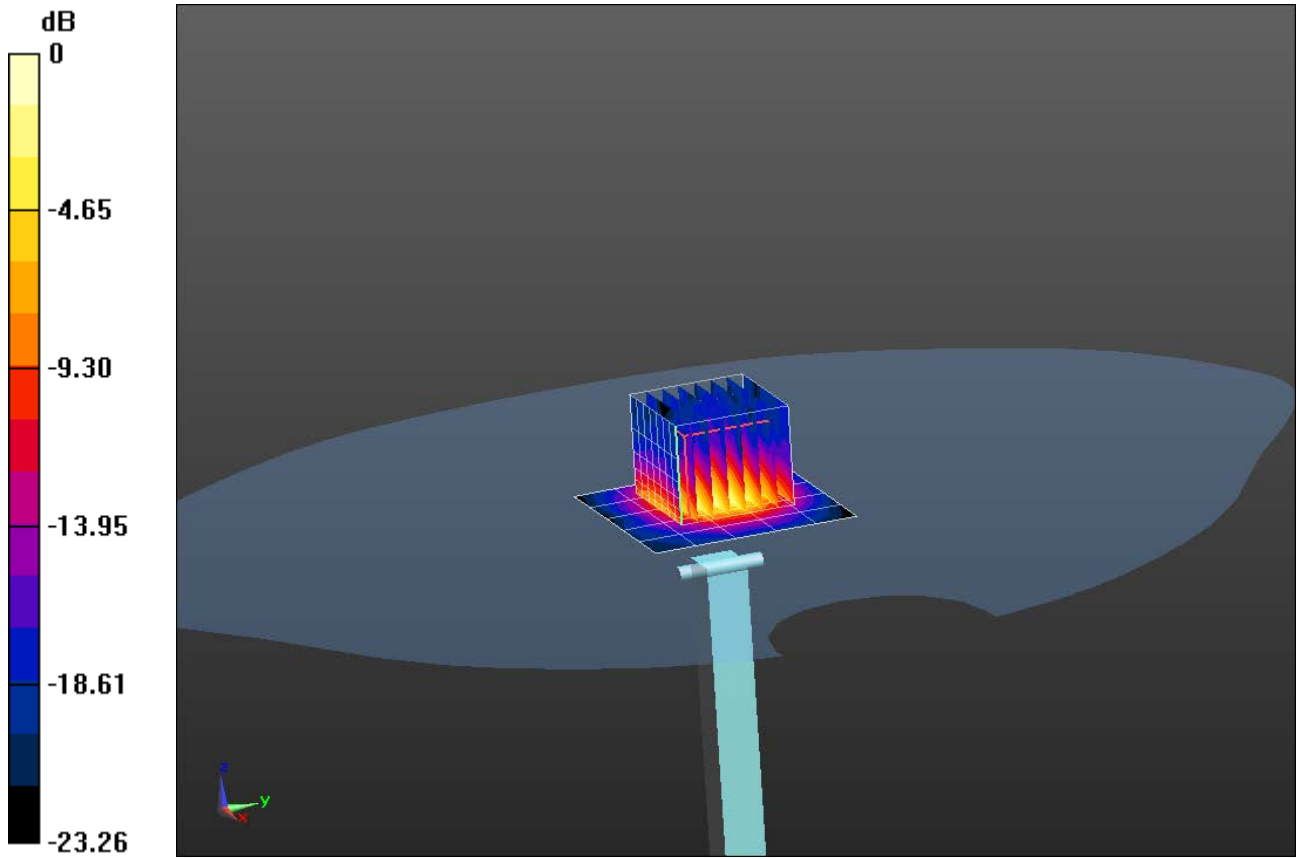

0 dB = 1.76 W/kg = 2.46 dBW/kg

Plot B 5

Date/Time: 4/24/2013 2:24:14 PM

Test Laboratory: Intertek

5GHz Dipole Validation 4_24_13**DUT: Dipole D5GHzV2; Type: D5GHzV2; Serial: D5GHzV2 - SN:xxx**

Communication System: CW; Communication System Band: D5GHz (5000.0 - 6000.0 MHz);
Frequency: 5800 MHz; Communication System PAR: 0 dB; PMF: 1
Medium parameters used: $f = 5800$ MHz; $\sigma = 6.07$ S/m; $\epsilon_r = 46$; $\rho = 1000$ kg/m³
Phantom section: Flat Section
Measurement Standard: DASYS (IEEE/IEC/ANSI C63.19-2007)

DASY Configuration:

- Probe: EX3DV3 - SN3516; ConvF(3.95, 3.95, 3.95); Calibrated: 12/10/2012;
 - Modulation Compensation:
- Sensor-Surface: 1.4mm (Mechanical Surface Detection), $z = 1.0, 25.0$
- Electronics: DAE4 Sn358; Calibrated: 9/11/2012
- Phantom: SAM 1 with CRP v5.0; Type: QD000P40CD; Serial: TP: 1243
- DASYS 52.8.5(1059); SEMCAD X 14.6.8(7028)

**System Performance Check with D5GHzV2 Dipole (graded grid)/d=10mm,
Pin=100mW, f=5800 MHz/Area Scan (6x6x1):** Measurement grid: dx=10mm, dy=10mm
Maximum value of SAR (measured) = 1.64 W/kg

**System Performance Check with D5GHzV2 Dipole (graded grid)/d=10mm,
Pin=100mW, f=5800 MHz/Zoom Scan (4x4x1.4mm, graded), dist=1.4mm
(8x8x7)/Cube 0:** Measurement grid: dx=4mm, dy=4mm, dz=1.4mm
Reference Value = 16.436 V/m; Power Drift = 0.16 dB
Peak SAR (extrapolated) = 315 W/kg
SAR(1 g) = 70.8 W/kg; SAR(10 g) = 19.7 W/kg
Normalized to target power = 1 W and actual power = 0.01 W
Maximum value of SAR (measured) = 171 W/kg

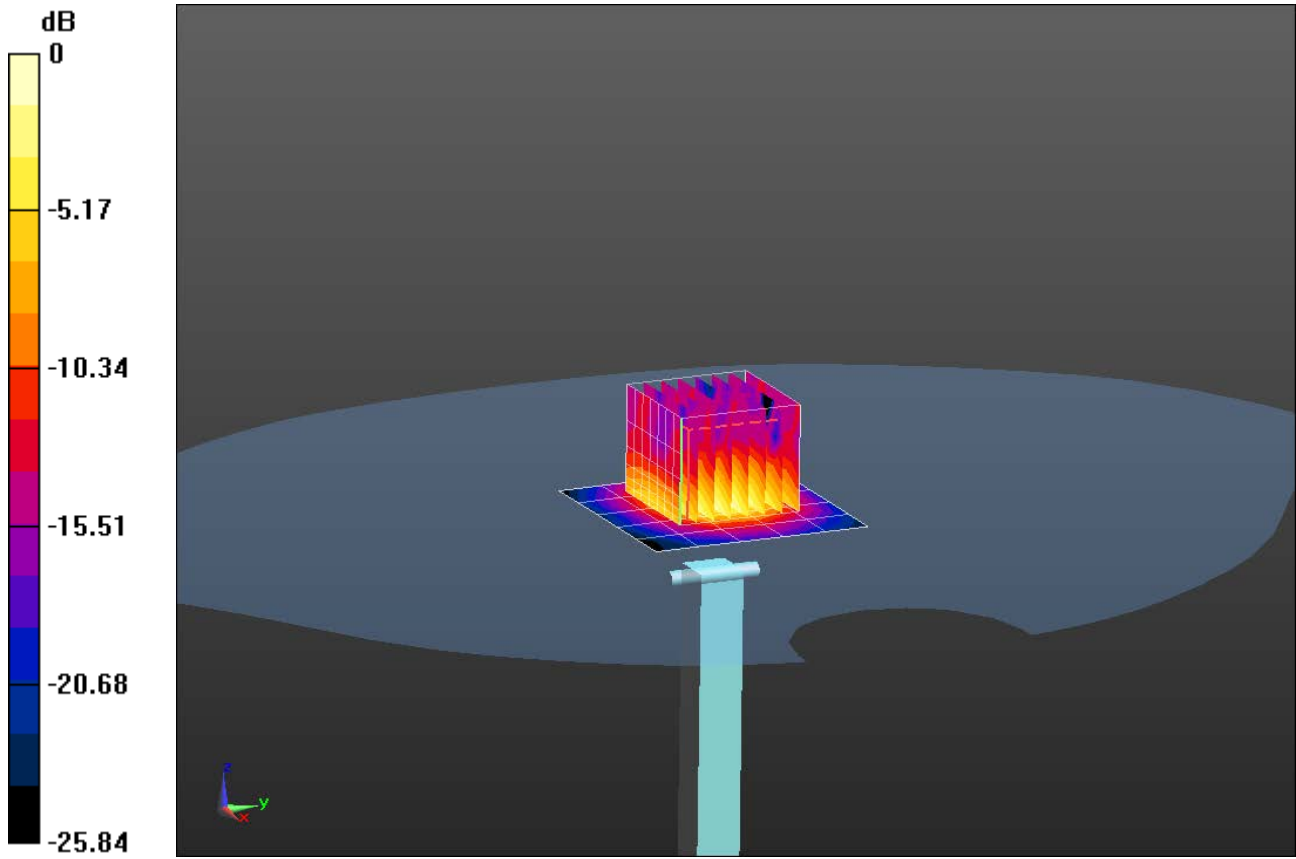

0 dB = 1.64 W/kg = 2.15 dBW/kg

13.0 APPENDIX C – SYSTEM VALIDATION SUMMARY

Per FCC KDB 865664, a tabulated summary of the system validation status including the validation date(s), measurement frequencies, SAR probes and tissue dielectric parameters have been included in the summary table below. The validation was performed with reference dipoles using the required tissue equivalent media for system validation according to KDB 865664. Each probe calibration point was validated at a frequency within the valid frequency range of the probe calibration point. All measurements were performed using probes calibrated for CW signals. Modulations in the table above represent test configurations for which the SAR system has been validated. The SAR system was also validated with modulated signals per KDB 865664.

Frequency (MHz)	Date	Probe (SN#)	Probe (Model #)	Probe Calibration Point		Dielectric Properties		CW Validation			Modulation Validation		
				Frequency (MHz)	Fluid Type	σ	ϵ_r	Sensitivity	Probe Linearity	Probe Isotropy	Mod. Type	Duty Factor	PAR
2450	1/7/2013	3516	EX3DV3	2450	Body	50.65	2.02	Pass	Pass	Pass	OFDM	N/A	Pass
5200	1/8/2013	3516	EX3DV3	5200	Body	48.71	5.54	Pass	Pass	Pass	OFDM	N/A	Pass
5500	1/8/2013	3516	EX3DV3	5500	Body	47.68	6.29	Pass	Pass	Pass	OFDM	N/A	Pass
5800	1/8/2013	3516	EX3DV3	5800	Body	48.71	5.54	Pass	Pass	Pass	OFDM	N/A	Pass

Table 21: SAR System Validation Summary