

Ubiqconn Technology, Inc

TI 4460 JORJIN ATCN08AJS-02
1240E8 (01-12138-01)

TI 4470 JORJIN ATFE08AJS-02
123501E8

Project Name : TomCat-U
Project Code : I12G00
Version : 0.2

Initial Date : 2012.12.25_07

Leader Sign by: Steven Chang

Drawing by : Gary Yang

Page Description

PAGE 01 .COVER SHEET	PAGE 24 1.2M CAM + PS 3 /D_MIC Board
PAGE 02 Desigh History	PAGE 25 WG7550 Board
PAGE 03 Block Diagram	PAGE 26 RTS5169 Board
PAGE 04 OMAP4-WL/BT/GPS/3G	PAGE 27 FUN_KEY Board
PAGE 05 NFC	PAGE 28 USB_LAN/HDMI_IN Board
PAGE 06 OMAP4-USB/HUB	PAGE 29 DOCKING Board
PAGE 07 OMAP4-uSD/eMMC	
PAGE 08 OMAP4-HDMI/SDXC/DISPLAY	
PAGE 09 OMAP4-LVDS/TOUCH	
PAGE 10 OMAP4-Camera S/W HDMI_IN	
PAGE 11 OMAP4-Camera 5M_1.2M	
PAGE 12 OMAP4-Audio Codec	
PAGE 13 Audio Jack/MIC/Speaker	
PAGE 14 OMAP4-IOs/W-key+PS2/4 CONN	
PAGE 15 OMAP4-SYS/PMIC/OTG_USB	
PAGE 16 OMAP4-Grounding	
PAGE 17 PIC Contro /VRTC	
PAGE 18 ADPIN/Charger/Battery	
PAGE 19 3/5VDDA/M/SYS1.8V/PS3V	
PAGE 20 Ext USB CONN /CLIP	
PAGE 21 LCD Boost 28V	
PAGE 22 SENSORS	
PAGE 23 WK-KEY + PS 2 Board	

Polyswitch Name	Current	Voltage	Page
FS5(DOCKING USB4)	0.5A~1.5A	6V~8V	20
FS2(USB UWB)	0.5A~1.5A	6V~8V	20
FS3(USB CAC)	0.5A~1.5A	6V~8V	20
FS4(USB)	0.5A~1.5A	6V~8V	20
F1 (DC_IN)	7A	32V	18
FS1(USB LAN)	0.5A~1.5A	6V~8V	10

SYSTEM LABEL

ECN LABEL

LABEL2

BAR_CODE

LAN ID LABEL

BIOS F.W LABEL EN LR

		Ubiqconn Technology, Inc.	
		4F1, No.300, Yang Guang St., Neihu 114 TAIPEI, TAIWAN, R.O.C. (886-2)8751-6008	
Title		TomCat-U I12G00	
Size	Document Number	Rev	
C	01. Cover Sheet	0.2	
Date: Wednesday, December 26, 2012 Sheet 1 of 30			

GPI/O_LIST

GPI/O	I/O	NET	説明
GP110	I	MCBSP2_CLK	FOR TC358743XBG I2S/TDM Bit Clock signal
GP111	I	MCBSP2_DR	FOR TC358743XBG I2S/TDM data signal
GP113	I	MCBSP2_FSK	FOR TC358743XBG I2S Word Clock or TDM Frame Sync signal
GP123	I	BT_UR_RTS	FOR AM-NB099H & WGT5550
GP124	O	BT_UR_CTS	FOR AM-NB099H & WGT5550
GP125	I	BT_UR_RX	FOR AM-NB099H & WGT5550
GP126	O	BT_UR_RX	FOR AM-NB099H & WGT5550
GP114	I/O	BT_PCM_CLK	FOR AM-NB099H & WGT5550
GP115	I	BT_PCM_OUT	FOR AM-NB099H & WGT5550
GP116	O	BT_PCM_IN	FOR AM-NB099H & WGT5550
GP117	I/O	BT_PCM_SYNC	FOR AM-NB099H & WGT5550
GP145	O	WL_SDIO_CLK	FOR AM-NB099H & WGT5550
GP146	I/O	WL_SDIO_CMD	FOR AM-NB099H & WGT5550
GP147	I/O	WL_SDIO_D0	FOR AM-NB099H & WGT5550
GP148	I/O	WL_SDIO_D1	FOR AM-NB099H & WGT5550
GP149	I/O	WL_SDIO_D2	FOR AM-NB099H & WGT5550
GP150	I/O	WL_SDIO_D3	FOR AM-NB099H & WGT5550
GP157	I	SDXC_CD_GP157	FOR SDXC C/D IN (L=CARD IN , H=CARD OUT)
PWM1	O	PWM_WLED	FOR TORCH/FLASH LED TP661050
PWM2	O	PWM_BL	FOR LCD BLK PWM
GP81	O	SM_PREX	FOR SM Camera PREX
GP82	O	SM_STROBE	FOR SM Camera STROBE
GP83	O	SM_GLOBAL_RST	FOR SM Camera GLOBAL RST
GP02	O	HDMI_IN_POWER_GP02	FOR TC358743XBG POWER ON (H=ON , L=OFF)
GP178	I	HDMI_OUT_INT_GP178	FOR TC358743XBG INT
GP177	I	NFC_IRQ_GP177	FOR NFC IRQ
GP176	O	NFC_VEN_GP176	FOR NFC (H=Enable,L=disable) LDO regulator / Reset
GP175	I/O	NFC_UPLDAD_GP175	FOR NFC UPLDAD
GP01	O	BT_WAKE_EN_GP1	FOR AM-NB099H BT device wake-up
GP00	O	GPS_RST_N_GP0	FOR AM-NB099H GPS Reset Pin, Low Active.
GP174	O	GPS_POWER_ON_GP174	FOR AM-NB099H GPS Power-on Signal Input
GP173	O	BT_SHUTDOWN_N_GP173	FOR AM-NB099H BT Power-down Signal Input
GP172	I	BT_HOST_WAKE_GP172	FOR AM-NB099H BT Sleep Signal OUT
GP171	I	WL_HOST_WAKE_GP171	FOR AM-NB099H WL Sleep Signal OUT
GP134	O	BT_RST_N_GP134	FOR AM-NB099H Low Asserting Reset for Bluetooth Core.
GP135	O	WL_SHUTDOWN_N_RST_GP135	FOR AM-NB099H Low asserting shutdown/reset for WLAN.
GP136	O	HDMI_IN_RSET_GP136	FOR TC358743XBG System reset input, active low
GP137	O	HDMI_IN_SLEEP_GP137	FOR TC358743XBG VDDC2 can be shut-off during deep sleep mode
GP138	I	GPS_UART_TX_GP141 UART1	FOR AM-NB099H GPS UART Transmit Output
GP139	I	GPS_UART_nRTS_GP140 UART1	FOR AM-NB099H GPS UART Request To Send
GP140	I	GPS_UART_nCTS_GP139 UART1	FOR AM-NB099H GPS UART Clear To Send
GP151	O	SDXC_CLK	SDMMC4 FOR Ext_SD_CARD CLK
GP152	I/O	SDXC_CMD	SDMMC4 FOR Ext_SD_CARD CMD
GP153	I/O	SDXC_DAT0	SDMMC4 FOR Ext_SD_CARD DAT0
GP154	I/O	SDXC_DAT3	SDMMC4 FOR Ext_SD_CARD DAT3
GP119	O	ABE_DMIC_CLK_GP119	FOR D_MIC CLK
GP120	I	ABE_DMIC_DIN_GP120	FOR D_MIC Left/right FDM data output
GP141	O	GPS_UART_RX_GP138 UART1	FOR AM-NB099H GPS UART Receive Input
GP32	O	3.5G_PWR_ON#	FOR 3G USB Mini Card POWER ON (Active Hi)
GP33	O	3.5G_EN#	FOR 3G USB Mini Card EN Active Low
GP33	O	3.5G_RESET	FOR 3G USB Mini Card RESET Active Hi
GP35	I	GPIO_35_TOUCH_INT	FOR Touch INT
GP36	I	SDXC_WP_GP36	SDMMC4 FOR Ext_SD_CARD WP Hi=Lock , Low=Unlock
GP37	O	GPIO_37_SM_FDW	FOR SM Camera Power ON Hi=ON , Low=OFF
GP38	I	3GCAD_DE_GP38	FOR 3G SIM CARD DE IN=HI ,OUT=low
GP39	O	GPIO_39_2M_FDW	FOR 1.2M Camera Power ON Hi=ON , Low=OFF
GP155	I/O	SDXC_DAT2	SDMMC4 FOR Ext_SD_CARD DAT2
GP156	I/O	SDXC_DAT1	SDMMC4 FOR Ext_SD_CARD DAT1

GPI/O	I/O	NET	説明
GP40	O	WLED_ON	FOR Torch/Flash ON
GP41	O	HDMI_LS_OE	FOR HDMI_OUT Level Shifting Buffer LS_OE active-high
GP42	I	ACCELE_INT1	FOR G-Sensor INT1
GP43	I	ACCELE_INT2	FOR G-Sensor INT2
GP44	I	KEY_VP_GP44	FOR Volume UP KEY Active-low
GP45	I	KEY_WK_GP45	FOR Windows KEY Active-low
GP46	I	KEY_VD_GP46	FOR Volume Down KEY Active-low
GP47	I	KEY_RL_GP47	FOR Rotation_Lock KEY Active-low
GP48	I	P_SENSOR_INT_GP48	FOR Proximity Sensor INT Active-low
GP50	O	TOUCH_RST_GP50	FOR TOUCH_RST Active-Low
GP53	I	WL_IRQ#_GP53	FOR WGT5550 WLAN_IRQ Active-low
GP54	O	WL_EN_GP54	FOR WGT5550 WLAN reset
GP55	O	BT_EN_GP55	FOR WGT5550 BT reset
GP56	O	WGT5550_PWRON_GP56	FOR WGT5550 POWER HI=ON LOW=OFF
GP59	O	ECOMP_RST	FOR E-COMPASS_RST Active Low
GP60	O	HDMI_CT_CP_HPD	FOR HDMI_OUT Level Shifting Buffer CT_HPD active-high
GP62	O	HUB_NRESET	FOR USB ULPI RESET Active Low
GP100	I	ALS_INT	FOR A-Light Sensor INT Active Low
GP101	I	GYRO_INT	FOR Gyroscope INT
GP102	O	PANEL_VDD_EN	FOR LCD PANEL VDD HI=ON LOW=OFF
GP103	O	PANEL_VLED_EN	FOR LCD PANEL VLED HI=ON LOW=OFF
GP104	I	3.5G_UP_GP104	FOR USB 3G CARD UP PME
GP122	O	1.2M_RST_GP122	FOR 1.2M Camera_RST
GP142	I	PIC_GP142	FOR PIC_INT

BOOT_S/W ON=HI OFF=LOW

Bit	0	1	2	3	4	5
SW2	1	2	3	4	5	6
Ext_USD_MMC1	ON	OFF	ON	OFF	OFF	ON
eMMC_MMC2	OFF	OFF	OFF	OFF	OFF	ON
AUTO_BOOT	OFF	OFF	OFF	OFF	OFF	ON
USD_TO_eMMC	OFF	ON	ON	OFF	ON	OFF

I2C Address

I2C_1	Address
Audio Codec	TWL6041 Audio IC 0x4b

I2C_2	Address
Touch	ELITEK 0x41
LCD (ADIP)	MV101HD1-1E1 0x50

I2C_3	Address
1.2M Camera	CM0-045A8-1A06(0V5640) 0x3C
1.2M Camera	CBFAL81(M9M114) 0x48
FLASH	TP861050 0x33
2M Camera	TC358743XBG 0x3C
HDMI_IN	TC358743XBG 0x0F

I2C_4	Address
G-Sensor	ADXL345BCC2 0x53
Gyroscope	MPU-3050 0xC8
E-Compass	YAS529 0x2E
A-Light Sensor	AL3090A 0x1C
Temp Sensor	TI 4460 0x48
PIC	18F25K20 0x38
EEPROM	A724C020C 0x57
NFC	LKRWAMHAAA-014 0x28

Ubiqconn Confidential

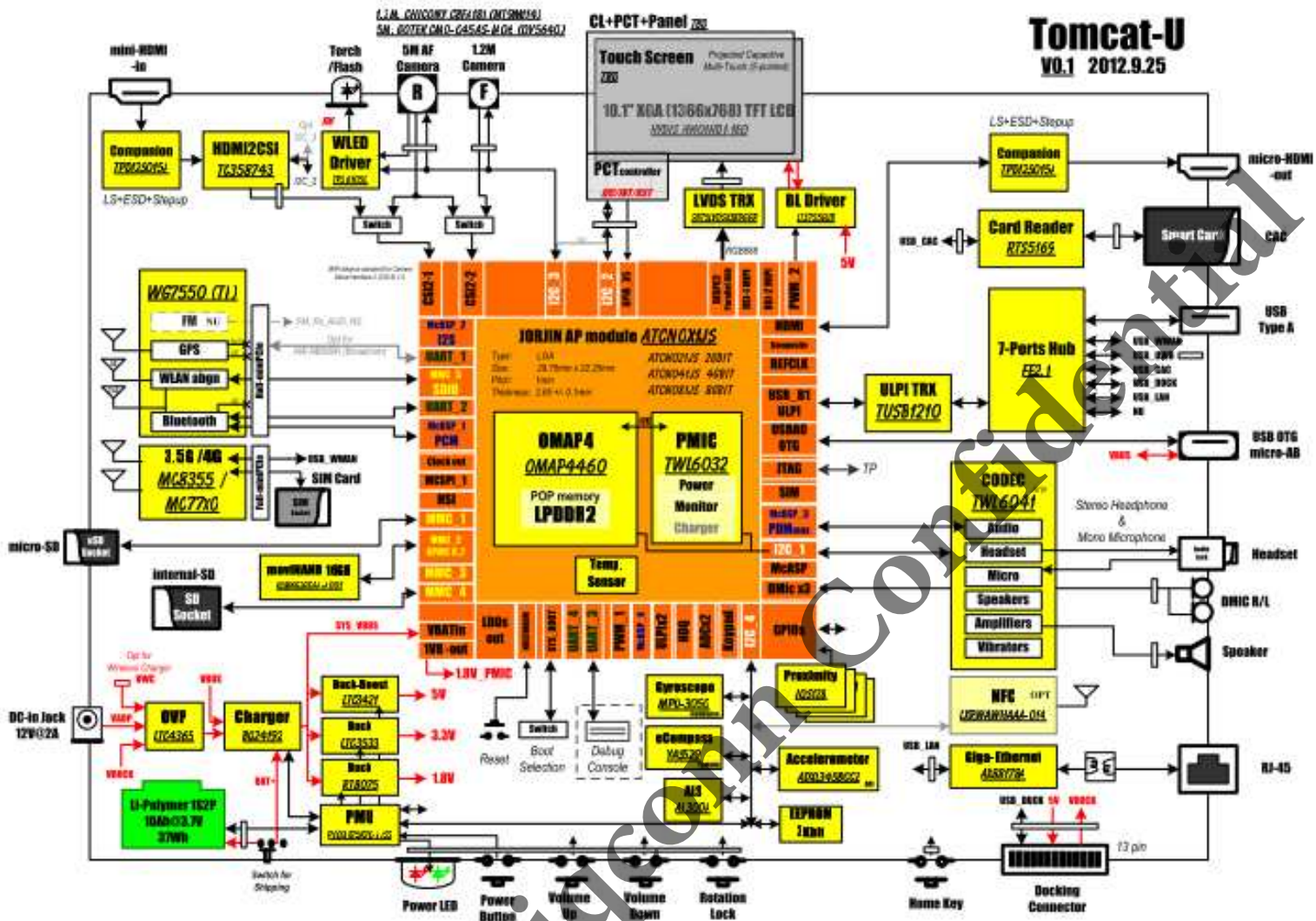

Ubiquconn Technology, Inc.
4FL., No.300, Yang Guang St., NeiHu
114 TAIPEI, TAIWAN, ROC
(886-2)8751-6008

Title		
TomCat-U I12G00		
Size A	Document Number	Rev 0.2
03. Block Diagram		
Date:	Wednesday, December 26, 2012	Sheet 3 of 30

OMAP -WL/BT/GPS

01-12135-01 ATNCO2LJ7S
 01-12133-01 ATNCO4LJ7S
 01-12134-01 ATNCO8LJ7S

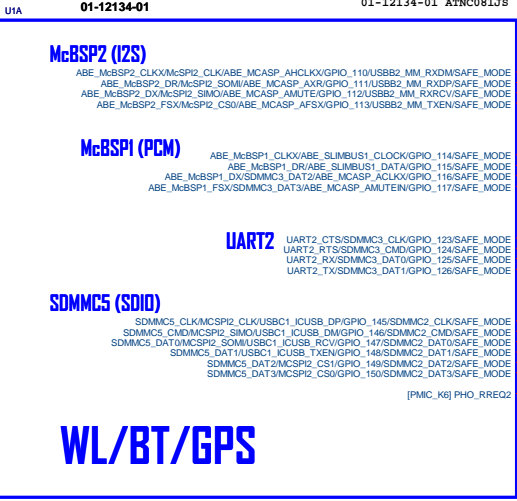

短卡 WL/BT/GPS

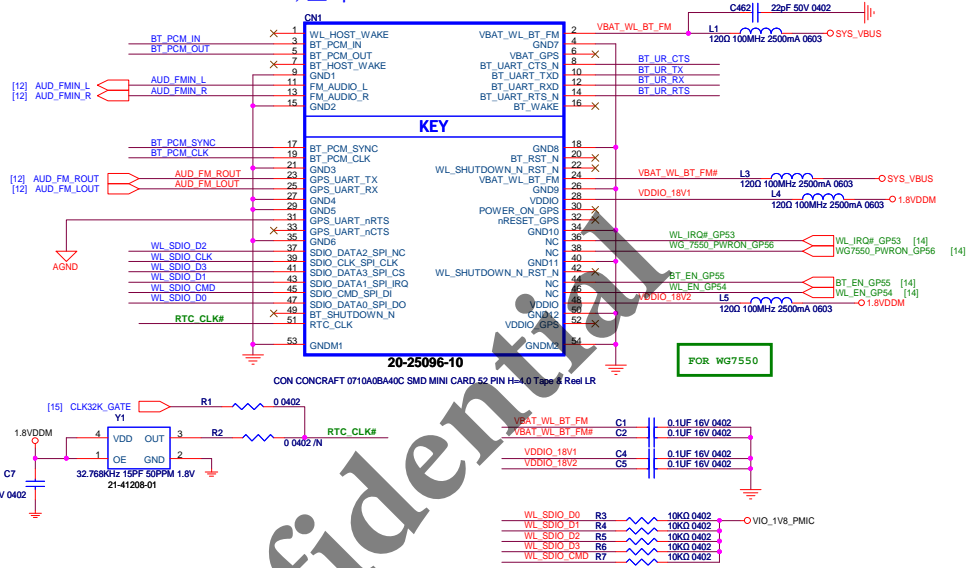

長卡 3G

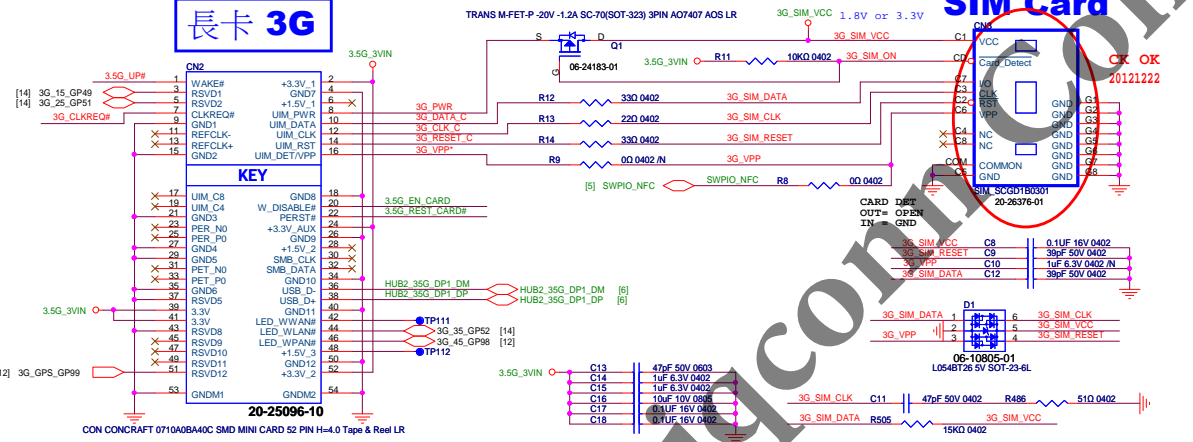

SIM Card

3G Power

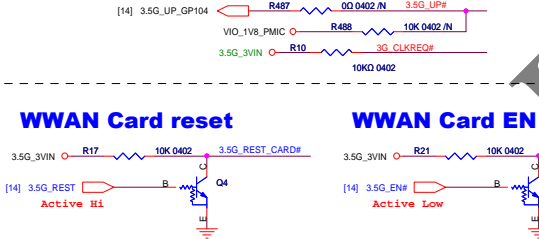
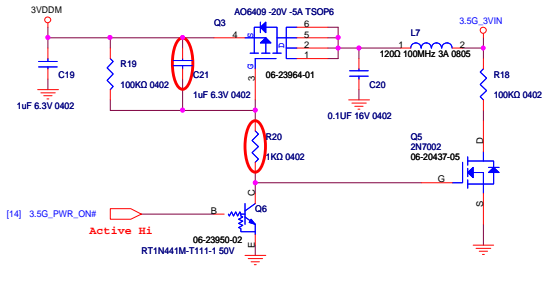

3GCD_DE

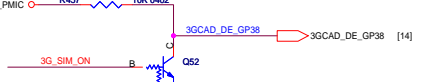

5VDDM	5VDDM	5VDDM	[6,8,10,12,19,20]
3G_SIM_VCC	3G_SIM_VCC	3G_SIM_VCC	[9]
1.8VDDM	1.8VDDM	1.8VDDM	[5,10,11,19]
PMU3V	PMU3V	PMU3V	[9,14,15,17,19]
SYS_VBUS	SYS_VBUS	SYS_VBUS	[19]
3VDDM	3VDDM	3VDDM	[5,6,7,8,9,10,11,12,14,17,19,21]
VIO_1V8_PMIC	VIO_1V8_PMIC	VIO_1V8_PMIC	[6,7,8,9,10,12,14,15,17,21]
3.5G_3VIN	3.5G_3VIN	3.5G_3VIN	[4]

Ubiquconn Technology, Inc.
 #FL-No.300 Yang Guang St. NeiHu
 114 Taipei, TAIWAN, R.O.C.
 (886-2)8751-6008

File: **TomCat-U I12G00**
 Size: Document Number
 C: **04. OMAP4 -WL/BT/GPS/3G**
 Rev: 0.2
 Date: Wednesday, December 26, 2012 Sheet: 4 of 30

NFC

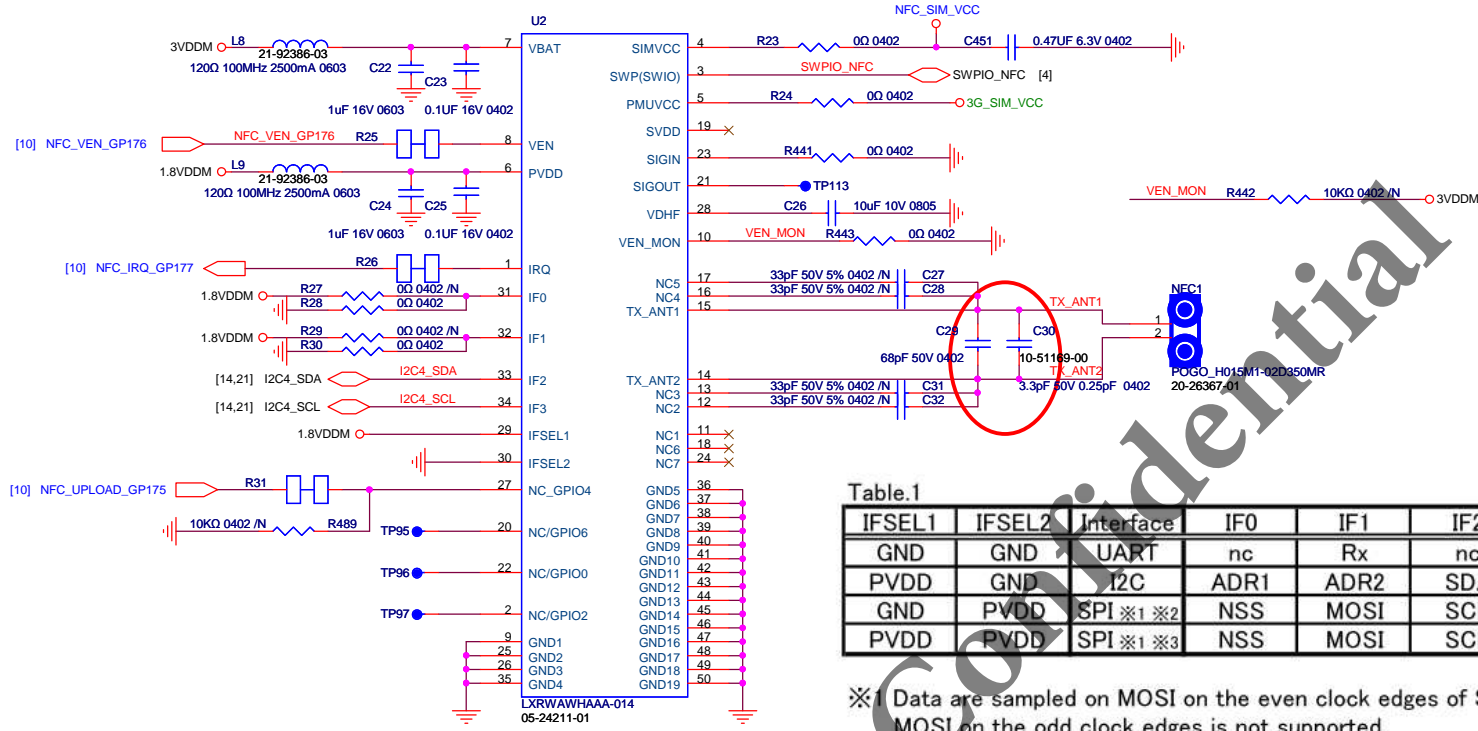

Table.1

IFSEL1	IFSEL2	Interface	IF0	IF1	IF2	IF3
GND	GND	UART	nc	Rx	nc	Tx
PVDD	GND	I2C	ADR1	ADR2	SDA	SCL
GND	PVDD	SPI ※1 ※2	NSS	MOSI	SCK	MISO
PVDD	PVDD	SPI ※1 ※3	NSS	MOSI	SCK	MISO

- ※1 Data are sampled on MOSI on the even clock edges of SCK after NSS goes low. MOSI on the odd clock edges is not supported.
- ※2 The clock is idle low, and the first valid edge of SCK will be a rising one.
- ※3 The clock is idle high, and the first valid edge of SCK will be a falling one.

Address	IF1	IF0
50H	0	0
52H	0	1
54H	1	0
56H	1	1

- 3G_SIM_VCC — 3G_SIM_VCC << 3G_SIM_VCC [4]
- VIO_1V8_PMIC — VIO_1V8_PMIC [4,6,7,8,9,10,12,14,15,17,21]
- 1.8VDDM — 1.8VDDM [4,10,11,19]
- 3VDDM — 3VDDM [4,6,7,8,9,10,11,12,14,17,19,21]

Ubiqconn Confidential

Ubiqconn Technology, Inc.
4FL, No.300, Yang Guang St., NeiHu
114 TAIPEI, TAIWAN, ROC
(886-2)8751-6008

Title: **TomCat-U I12G00**

Size B Document Number: **05.NFC** Rev 0.2

Date: Wednesday, December 26, 2012 Sheet 5 of 30

OMAP -USB/HUB/WWAN

USB HOST USB_B1_ULPI

```

USB1_ULPITLL_CLKHS1_CAWAKE/GPIO_84/USBB1_ULPIPHY_CLK/ATTILA_HW_DBG20/SAFE_MODE
USB1_ULPITLL_STP/HS1_CADATAM/BSIP4_CLKR/GPIO_85/USBB1_ULPIPHY_STP/USBB1_MM_RXDP/ATTILA_HW_DBG21/SAFE_MODE
USB1_ULPITLL_DIR/HS1_CAFLAG/MSBP4_FSX/GPIO_86/USBB1_ULPIPHY_DIR/ATTILA_HW_DBG22/SAFE_MODE
USB1_ULPITLL_NXT/HS1_ACREADY/MSBP4_FSX/GPIO_87/USBB1_ULPIPHY_NXT/USBB1_MM_RXDM/ATTILA_HW_DBG23/SAFE_MODE
USB1_ULPITLL_DAT0/HS1_ACWAKE/MSBP4_CLK/GPIO_88/USBB1_ULPIPHY_DAT0/USBB1_MM_TXEN/ATTILA_HW_DBG24/SAFE_MODE
USB1_ULPITLL_DAT1/HS1_CADATAM/BSIP4_DX/GPIO_89/USBB1_ULPIPHY_DAT1/USBB1_MM_TXDM/ATTILA_HW_DBG25/SAFE_MODE
USB1_ULPITLL_DAT2/HS1_ACFLAG/MSBP4_DR/GPIO_90/USBB1_ULPIPHY_DAT2/USBB1_MM_TXSE0/ATTILA_HW_DBG26/SAFE_MODE
USB1_ULPITLL_DAT3/HS1_CAREADY/GPIO_91/USBB1_ULPIPHY_DAT3/USBB1_MM_RXRCV/ATTILA_HW_DBG27/SAFE_MODE
USB1_ULPITLL_DAT4/HS1_CADATAM/BSIP4_DX/GPIO_92/USBB1_ULPIPHY_DAT4/ATTILA_HW_DBG28/SAFE_MODE
USB1_ULPITLL_DAT5/HS1_CADATAM/BSIP4_DX/GPIO_93/USBB1_ULPIPHY_DAT5/ATTILA_HW_DBG29/SAFE_MODE
USB1_ULPITLL_DAT6/HS1_CADATAM/BSIP4_DX/GPIO_94/USBB1_ULPIPHY_DAT6/HS1_MM_TXEN/ATTILA_HW_DBG30/SAFE_MODE
USB1_ULPITLL_DAT7/HS1_CADATAM/BSIP4_DX/GPIO_95/USBB1_ULPIPHY_DAT7/HS1_MM_TXEN/ATTILA_HW_DBG31/SAFE_MODE
    
```

ATNOC81JS 8GBIT

USB ULPI

VDD33 Reference clock input (square-wave only). Tie to GND when pin 26 (CLOCK) is required to be input mode. Connect to square-wave reference clock of amplitude in the range of 3 V to 3.6 V when pin 26 (CLOCK) is required to be output mode. See pin 14 (CFG) description for REFCLK input frequency settings.

REFCLK clock frequency configuration pin. Two frequencies are supported: 19.2 MHz when CFG=0, or 26 MHz when CFG=1.

USB 7 Port HUB

ASIC USB2.0 Hub Controller FE2.1 LOFP 48PIN TERMINUS LR

3.5G 3VIN ← 3.5G 3VIN [4]

VIO_1V8_PMIC ← VIO_1V8_PMIC [4,7,8,9,10,12,14,15,17,21]

3VDDM ← 3VDDM [4,5,7,8,9,10,11,12,14,17,19,21]

5VDDM ← 5VDDM [8,10,12,19,20]

Ubiqconn Technology, Inc.
4FL, No.300, Yang Guang St., NeiHu
114 TAIPEI, TAIWAN, R.O.C.
(886-2)8751-6008

TomCat-U I12G00

Size C Document Number **06. OMAP4-USB/HUB** Rev 0.2

Date: Wednesday, December 26, 2012 Sheet 6 of 30

OMAP -Storage

U18

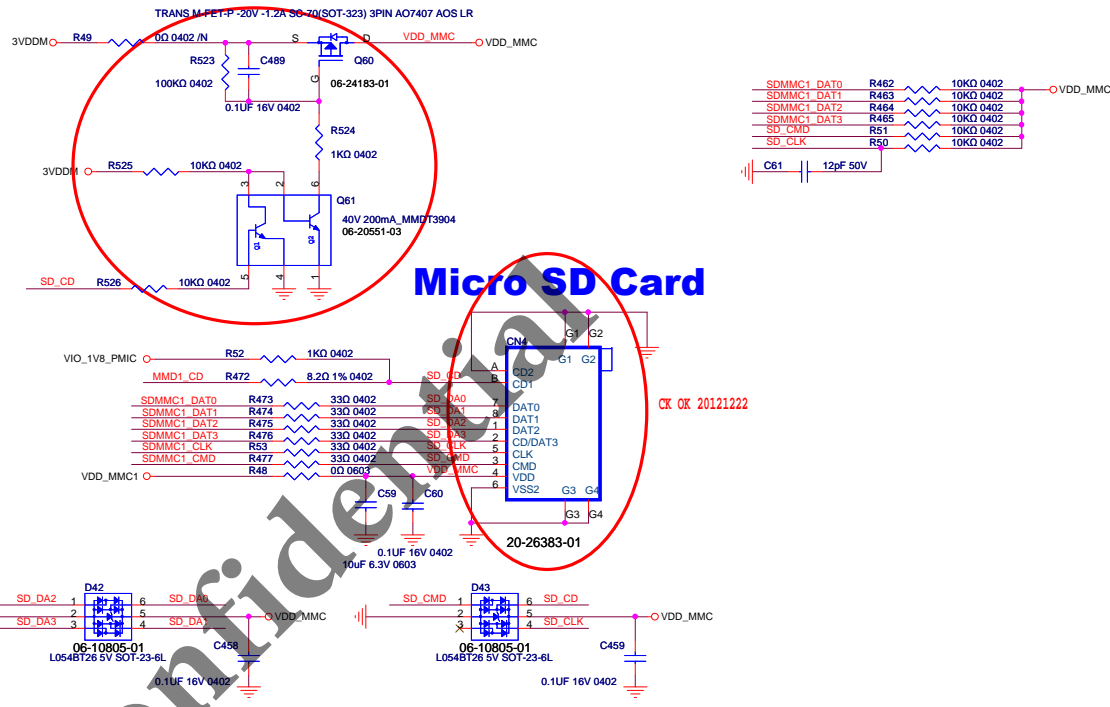
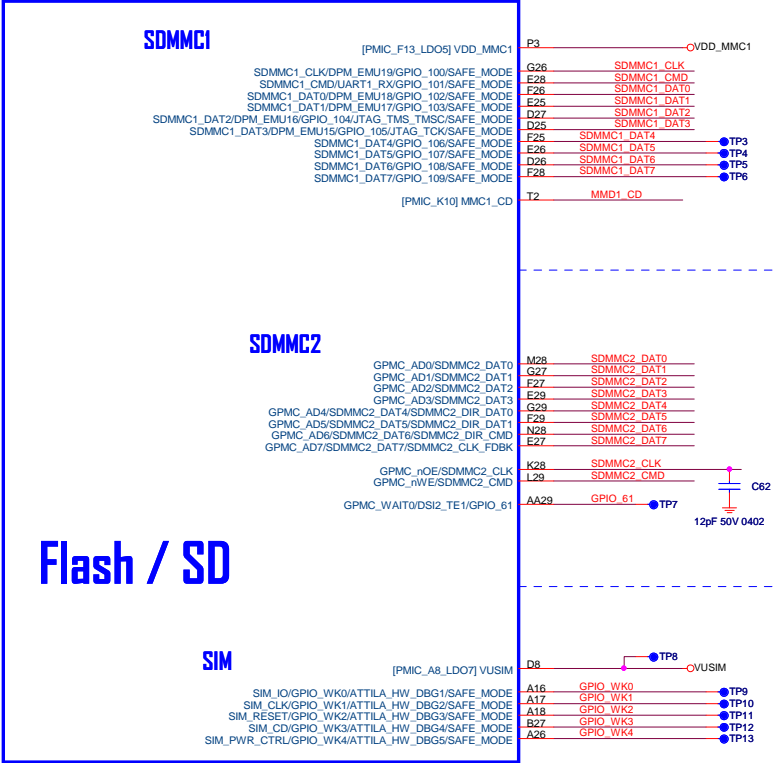

NC1	NC2	NC3	NC4	NC5	NC6	NC7	NC8	NC9	NC10	NC11	NC12	NC13	NC14	NC15	NC16	NC17	NC18	NC19	NC20	NC21	NC22	NC23	NC24	NC25	NC26	NC27	NC28	NC29	NC30	NC31	NC32	NC33	NC34	NC35	NC36	NC37	NC38	NC39	NC40	NC41	NC42	NC43	NC44	NC45	NC46	NC47	NC48	NC49	NC50	NC51	NC52	NC53	NC54	NC55	NC56	NC57	NC58	NC59	NC60	NC61	NC62	NC63	NC64	NC65	NC66	NC67	NC68	NC69	NC70	NC71	NC72	NC73	NC74	NC75	NC76	NC77	NC78	NC79	NC80	NC81	NC82	NC83	NC84	NC85	NC86	NC87	NC88	NC89	NC90	NC91	NC92	NC93	NC94	NC95	NC96	NC97	NC98	NC99	NC100	NC101	NC102	NC103	NC104	NC105	NC106	NC107	NC108	NC109	NC110	NC111	NC112	NC113	NC114	NC115	NC116	NC117	NC118	NC119	NC120	NC121	NC122	NC123	NC124	NC125	NC126	NC127	NC128	NC129	NC130	NC131	NC132	NC133	NC134	NC135	NC136	NC137	NC138	NC139	NC140	NC141	NC142	NC143	NC144	NC145	NC146	NC147	NC148	NC149	NC150	NC151	NC152	NC153	NC154	NC155	NC156	NC157	NC158	NC159	NC160	NC161	NC162	NC163	NC164	NC165	NC166	NC167	NC168	NC169	NC170	NC171	NC172	NC173	NC174	NC175	NC176	NC177	NC178	NC179	NC180	NC181	NC182	NC183	NC184	NC185	NC186	NC187	NC188	NC189	NC190	NC191	NC192	NC193	NC194	NC195	NC196	NC197	NC198	NC199	NC200	NC201	NC202	NC203	NC204	NC205	NC206	NC207	NC208	NC209	NC210	NC211	NC212	NC213	NC214	NC215	NC216	NC217	NC218	NC219	NC220	NC221	NC222	NC223	NC224	NC225	NC226	NC227	NC228	NC229	NC230	NC231	NC232	NC233	NC234	NC235	NC236	NC237	NC238	NC239	NC240	NC241	NC242	NC243	NC244	NC245	NC246	NC247	NC248	NC249	NC250	NC251	NC252	NC253	NC254	NC255	NC256	NC257	NC258	NC259	NC260	NC261	NC262	NC263	NC264	NC265	NC266	NC267	NC268	NC269	NC270	NC271	NC272	NC273	NC274	NC275	NC276	NC277	NC278	NC279	NC280	NC281	NC282	NC283	NC284	NC285	NC286	NC287	NC288	NC289	NC290	NC291	NC292	NC293	NC294	NC295	NC296	NC297	NC298	NC299	NC300	NC301	NC302	NC303	NC304	NC305	NC306	NC307	NC308	NC309	NC310	NC311	NC312	NC313	NC314	NC315	NC316	NC317	NC318	NC319	NC320	NC321	NC322	NC323	NC324	NC325	NC326	NC327	NC328	NC329	NC330	NC331	NC332	NC333	NC334	NC335	NC336	NC337	NC338	NC339	NC340	NC341	NC342	NC343	NC344	NC345	NC346	NC347	NC348	NC349	NC350	NC351	NC352	NC353	NC354	NC355	NC356	NC357	NC358	NC359	NC360	NC361	NC362	NC363	NC364	NC365	NC366	NC367	NC368	NC369	NC370	NC371	NC372	NC373	NC374	NC375	NC376	NC377	NC378	NC379	NC380	NC381	NC382	NC383	NC384	NC385	NC386	NC387	NC388	NC389	NC390	NC391	NC392	NC393	NC394	NC395	NC396	NC397	NC398	NC399	NC400	NC401	NC402	NC403	NC404	NC405	NC406	NC407	NC408	NC409	NC410	NC411	NC412	NC413	NC414	NC415	NC416	NC417	NC418	NC419	NC420	NC421	NC422	NC423	NC424	NC425	NC426	NC427	NC428	NC429	NC430	NC431	NC432	NC433	NC434	NC435	NC436	NC437	NC438	NC439	NC440	NC441	NC442	NC443	NC444	NC445	NC446	NC447	NC448	NC449	NC450	NC451	NC452	NC453	NC454	NC455	NC456	NC457	NC458	NC459	NC460	NC461	NC462	NC463	NC464	NC465	NC466	NC467	NC468	NC469	NC470	NC471	NC472	NC473	NC474	NC475	NC476	NC477	NC478	NC479	NC480	NC481	NC482	NC483	NC484	NC485	NC486	NC487	NC488	NC489	NC490	NC491	NC492	NC493	NC494	NC495	NC496	NC497	NC498	NC499	NC500
-----	-----	-----	-----	-----	-----	-----	-----	-----	------	------	------	------	------	------	------	------	------	------	------	------	------	------	------	------	------	------	------	------	------	------	------	------	------	------	------	------	------	------	------	------	------	------	------	------	------	------	------	------	------	------	------	------	------	------	------	------	------	------	------	------	------	------	------	------	------	------	------	------	------	------	------	------	------	------	------	------	------	------	------	------	------	------	------	------	------	------	------	------	------	------	------	------	------	------	------	------	------	------	-------	-------	-------	-------	-------	-------	-------	-------	-------	-------	-------	-------	-------	-------	-------	-------	-------	-------	-------	-------	-------	-------	-------	-------	-------	-------	-------	-------	-------	-------	-------	-------	-------	-------	-------	-------	-------	-------	-------	-------	-------	-------	-------	-------	-------	-------	-------	-------	-------	-------	-------	-------	-------	-------	-------	-------	-------	-------	-------	-------	-------	-------	-------	-------	-------	-------	-------	-------	-------	-------	-------	-------	-------	-------	-------	-------	-------	-------	-------	-------	-------	-------	-------	-------	-------	-------	-------	-------	-------	-------	-------	-------	-------	-------	-------	-------	-------	-------	-------	-------	-------	-------	-------	-------	-------	-------	-------	-------	-------	-------	-------	-------	-------	-------	-------	-------	-------	-------	-------	-------	-------	-------	-------	-------	-------	-------	-------	-------	-------	-------	-------	-------	-------	-------	-------	-------	-------	-------	-------	-------	-------	-------	-------	-------	-------	-------	-------	-------	-------	-------	-------	-------	-------	-------	-------	-------	-------	-------	-------	-------	-------	-------	-------	-------	-------	-------	-------	-------	-------	-------	-------	-------	-------	-------	-------	-------	-------	-------	-------	-------	-------	-------	-------	-------	-------	-------	-------	-------	-------	-------	-------	-------	-------	-------	-------	-------	-------	-------	-------	-------	-------	-------	-------	-------	-------	-------	-------	-------	-------	-------	-------	-------	-------	-------	-------	-------	-------	-------	-------	-------	-------	-------	-------	-------	-------	-------	-------	-------	-------	-------	-------	-------	-------	-------	-------	-------	-------	-------	-------	-------	-------	-------	-------	-------	-------	-------	-------	-------	-------	-------	-------	-------	-------	-------	-------	-------	-------	-------	-------	-------	-------	-------	-------	-------	-------	-------	-------	-------	-------	-------	-------	-------	-------	-------	-------	-------	-------	-------	-------	-------	-------	-------	-------	-------	-------	-------	-------	-------	-------	-------	-------	-------	-------	-------	-------	-------	-------	-------	-------	-------	-------	-------	-------	-------	-------	-------	-------	-------	-------	-------	-------	-------	-------	-------	-------	-------	-------	-------	-------	-------	-------	-------	-------	-------	-------	-------	-------	-------	-------	-------	-------	-------	-------	-------	-------	-------	-------	-------	-------	-------	-------	-------	-------	-------	-------	-------	-------	-------	-------	-------	-------	-------	-------	-------	-------	-------	-------	-------	-------	-------	-------	-------	-------	-------	-------	-------	-------	-------	-------	-------	-------	-------	-------	-------	-------	-------	-------	-------	-------	-------	-------	-------	-------	-------	-------	-------	-------	-------	-------	-------	-------	-------	-------	-------	-------	-------	-------	-------	-------	-------	-------

3VDDM ○ 3VDDM
VIO_V18_PMIC ○ VIO_V18_PMIC
VDD_AUX1_PMIC ○ VDD_AUX1_PMIC

Ubiqconn Technology, Inc.
4FL_No.300,Yang Guang St.,Neihu
114 TAIPEI, TAIWAN,ROC
(886-2)8751-6006

File: **TomCat-U H2G00**
Size: Document Number
Custom: **07. OMAP4-uSD/eMMC**
Date: **Wednesday, December 26, 2012**

Sheet 7 of 30

OMAP -HDMI

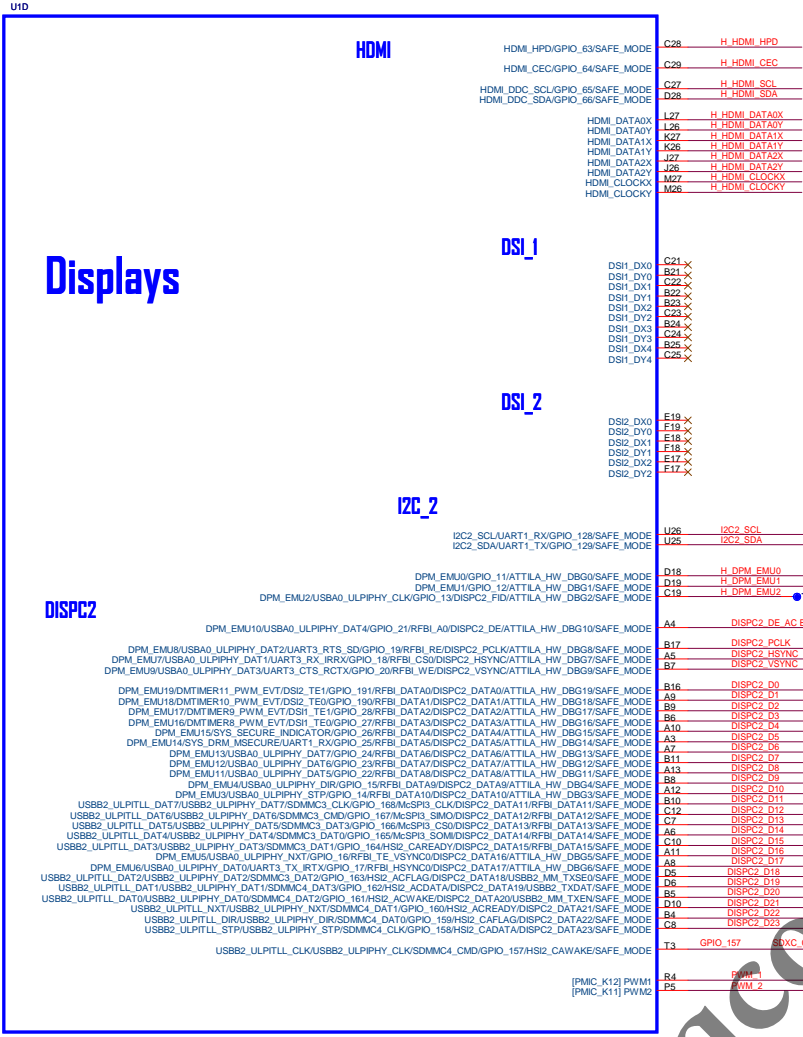

- Charge Pump/ESD/Level Translator

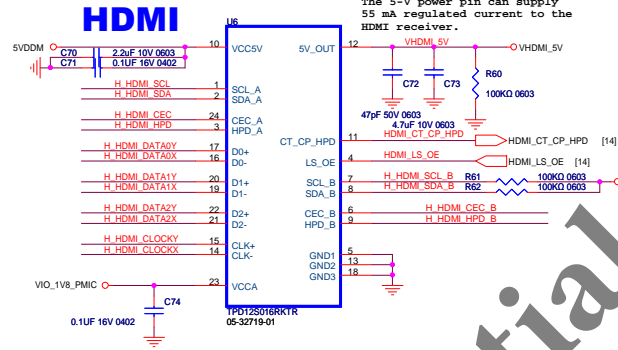

- Micro HDMI TYPE-D Female

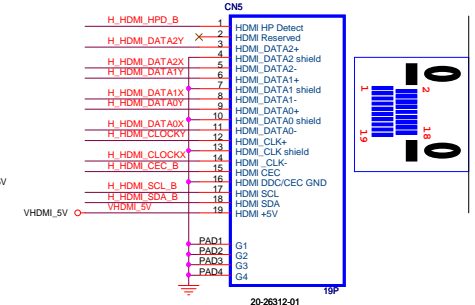

Displays

SDXC SD Card

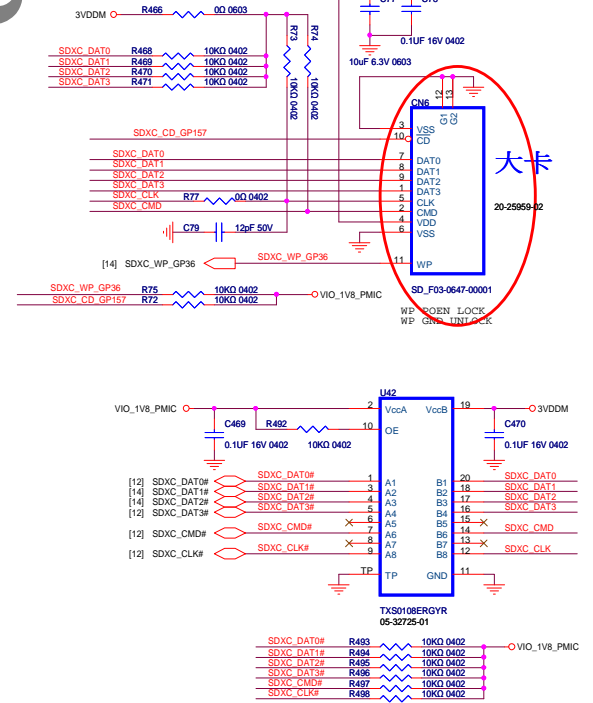

DISPCZ

ATNOC815 8GBIT

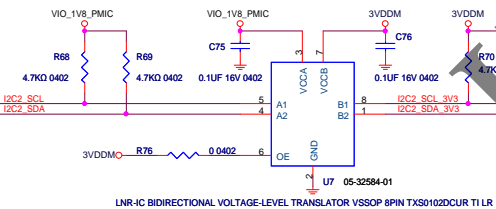

- VIO_1V8_PMIC -> VIO_1V8_PMIC [4,6,7,9,10,12,14,15,17,21]
3VDDM -> 3VDDM [4,5,6,7,9,10,11,12,14,17,19,21]
5VDDM -> 5VDDM [6,10,12,19,20]
LVDS_VCC -> LVDS_VCC [9]
VLED_VCC -> VLED_VCC [9]

Ubiqconn Technology, Inc.
4FL No.300 Yang Guang St., NeiHu 114 Taipei, TAIWAN, ROC.
(886-2)8751-6008
TomCat-U I12G00
08. OMAP4 -HDMI/SDXC/DISPC2
Rev 0.2
Date: Wednesday, December 26, 2012 Sheet 8 of 30

Dimming Frequency = 22KHz +- 2KHz

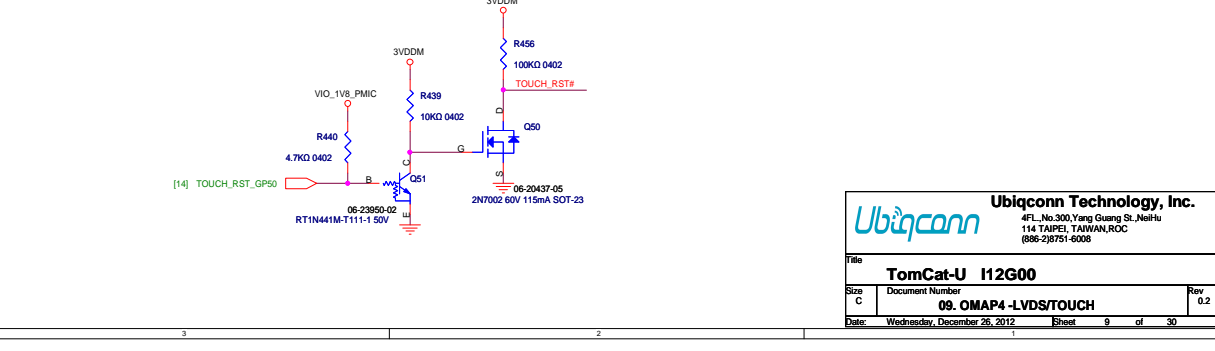
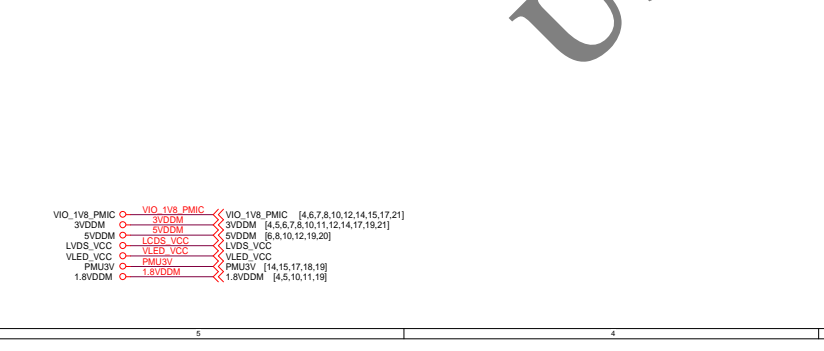
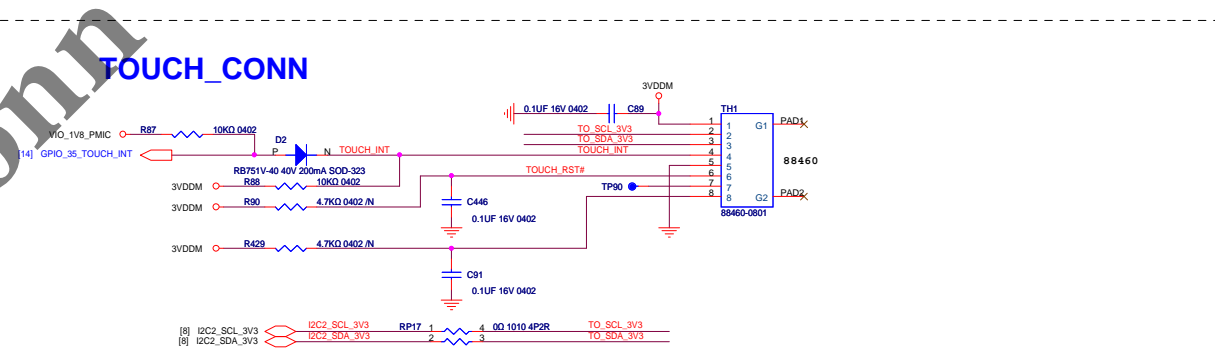
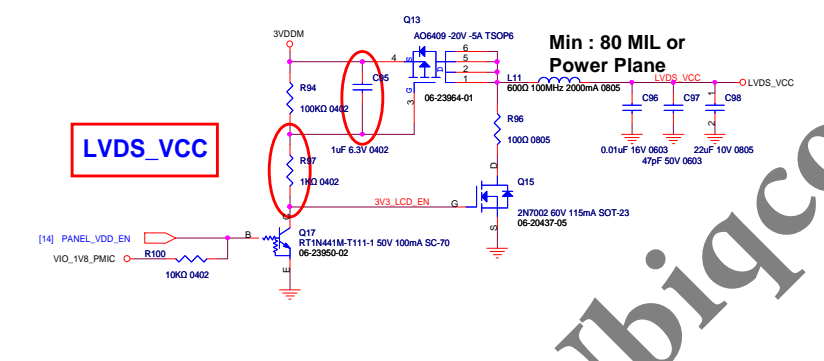
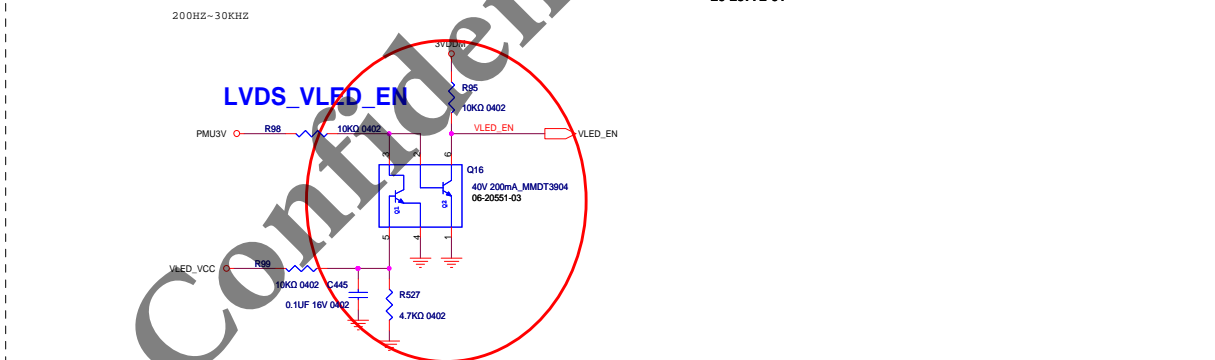
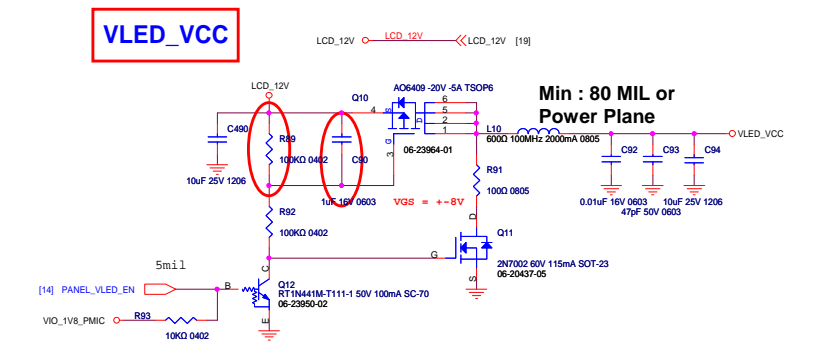
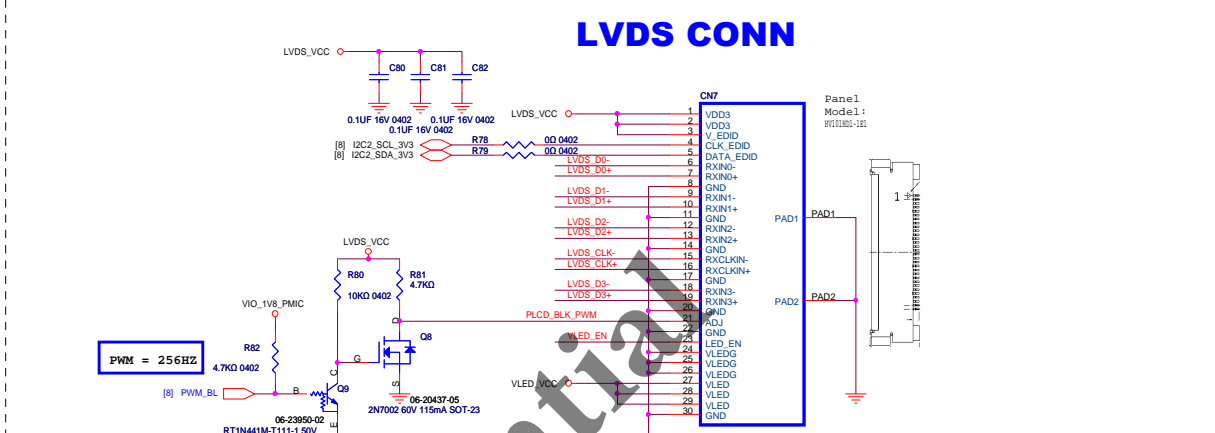
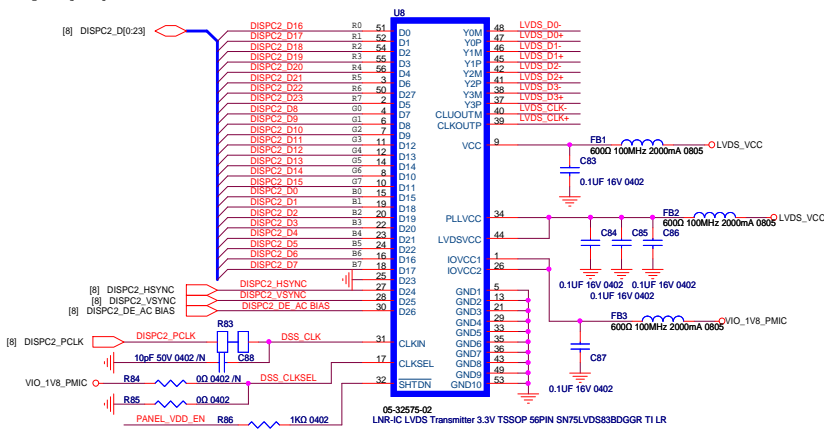

Ubiquconn Technology, Inc.
4FL, No.300, Yang Guang St., NeiHu
114 TAIPEI, TAIWAN, R.O.C.
(886-2)8751-6008

File	TomCat-U I12G00	
Size	Document Number	Rev 0.2
C	09_OMAP4-LVDS/TOUCH	
Date:	Wednesday, December 26, 2012	Sheet 9 of 30

OMAP -Camera

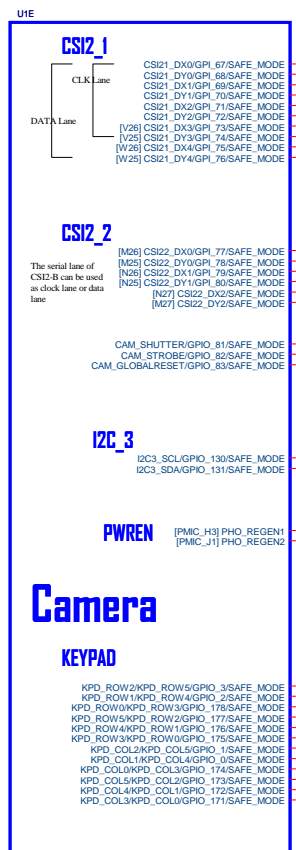

V22	P	CSI21_DX0	
U22	N	CSI21_DY0	
V21	P	CSI21_DX1	
U21	N	CSI21_DY1	
V20	P	CSI21_DX2	
U20	N	CSI21_DY2	
V19	P	CSI21_DX3	
U19	N	CSI21_DY3	
V18	P	CSI21_DX4	
U18	N	CSI21_DY4	

V24	P	CSI22_DX0	5M_MCP_D7 [11]
U24	N	CSI22_DY0	5M_MCN_D6 [11]
V23	P	CSI22_DX1	5M_MDP0_D5 [11]
U23	N	CSI22_DY1	5M_MDN0_D4 [11]
AA22	P	CSI22_DX2	5M_MDP1_D9 [11]
AA23	N	CSI22_DY2	5M_MDN1_D8 [11]

AA20	>	GPIO 81 R101	00/N	5M_FREX	5M_FREX [11]
AA15	>	GPIO 82 R102	00/N	5M_STROBE	5M_STROBE [11]
AA14	>	GPIO 85 R103	00	5M_GLOBAL_RSTF	5M_GLOBAL_RSTF [11]

Table2: to Flash/DLP
Table2: to Flash/DLP
Table2: Reset both Camera

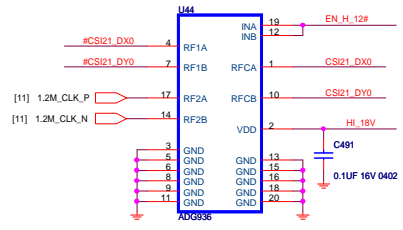
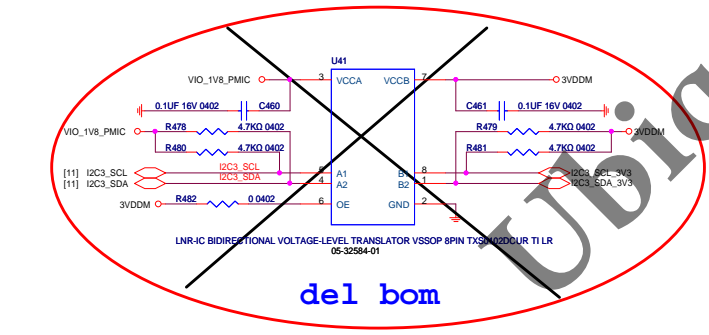

INx = H RF1 - HDMI_IN
INx = L RF2 - 1.2M

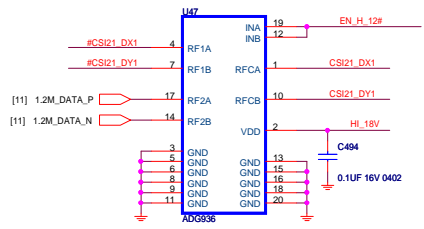

HDMI_IN / USB_LAN

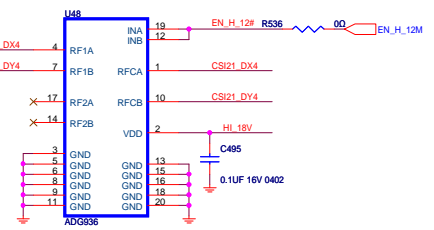
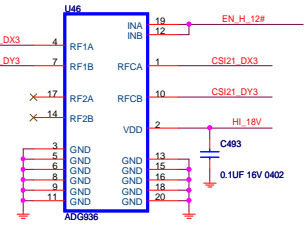
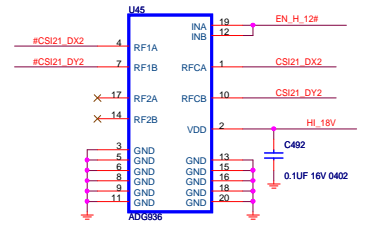
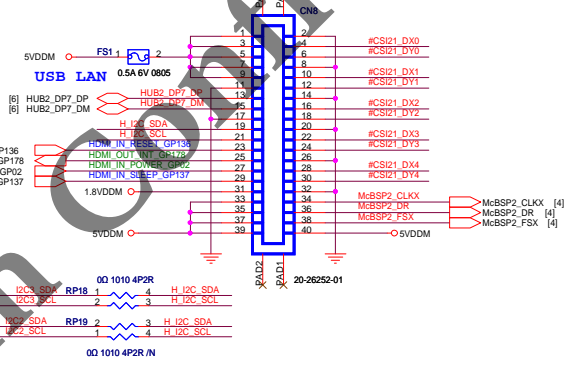

HDMI_IN+1.2M

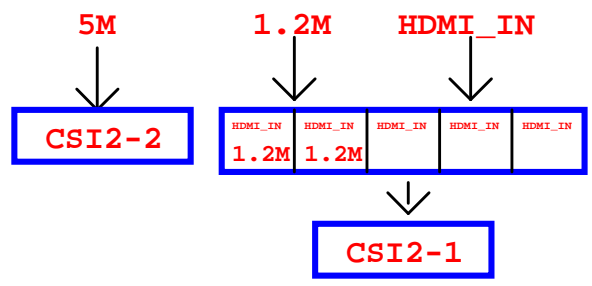
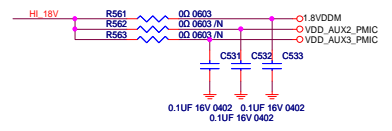

SVDDM	SVDDM [6,8,12,19,20]
3V3PS	3V3PS [11,14,19]
1.8VDDM	1.8VDDM [4,5,11,19]
3VDDM	3VDDM [4,5,6,7,8,9,11,12,14,17,19,21]
VIO_1V8_PMIC	VIO_1V8_PMIC [4,6,7,8,9,12,14,15,17,21]
VDD_AUX2_PMIC	VDD_AUX2_PMIC [15]
VDD_AUX3_PMIC	VDD_AUX3_PMIC [15]

Ubiqconn Technology, Inc.
4FL No.300 Yang Guang St. Neihu
114 Taipei, Taiwan, R.O.C.
(886-2)8751-6008

File	TomCat-U I12G00	
Size	Document Number	Rev 0.2
	10. OMAP4 -Camera SW HDMI_IN	
Date	Wednesday, December 26, 2012	Sheet 10 of 30

5M Camera

Gotek CM0-045AS-IA06 (OV5640)

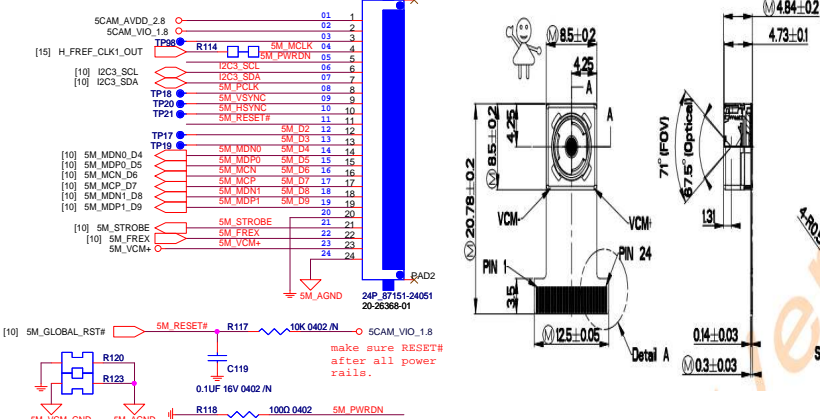

1.2M WebCam + PS 3

Chicony CBFA181 (MT9M114)

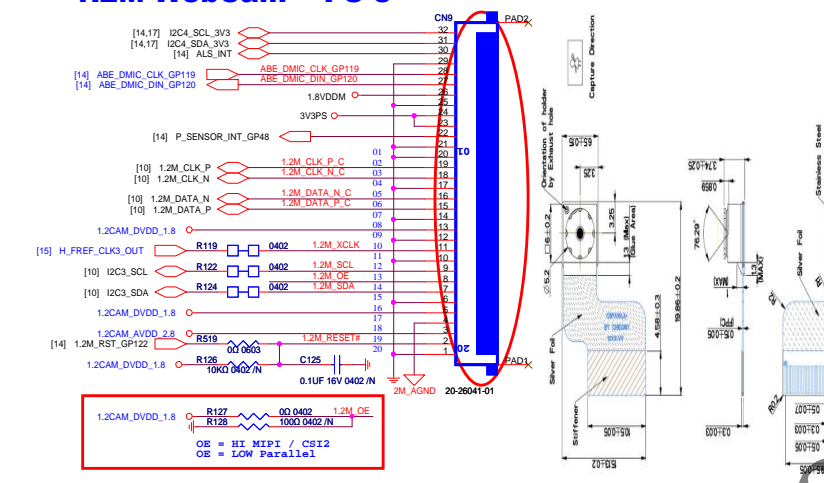

Torch/Flash

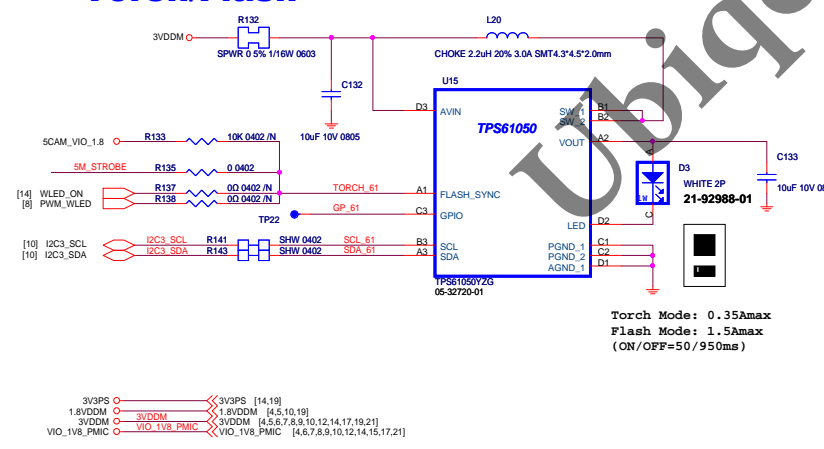

5CAM_AVDD_2.8

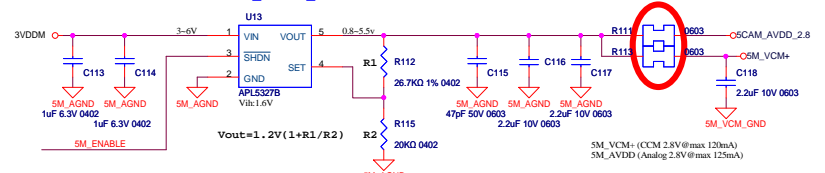

5CAM_VIO_1.8

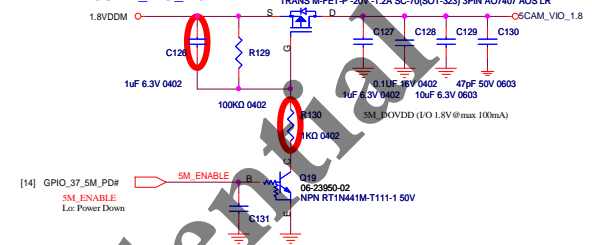

1.2CAM_AVDD_2.8

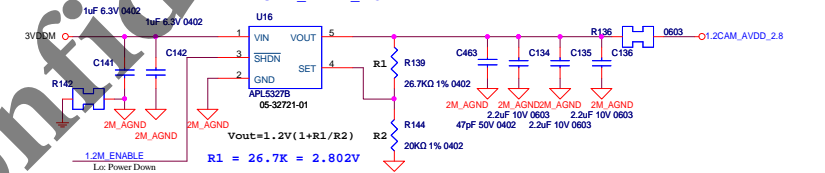

1.2CAM_DVDD_1.8V

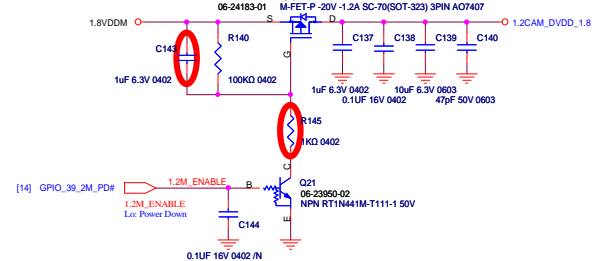

散熱設計指南

- FLASH LED 散熱設計
 - LED 載板，不推薦使用 FPC (導熱係數比較: MCPCB 金屬基板 > FR4 PCB > FPC)
 - LED 四周須讓出空間至少 80mm² 不可放置其他元件
 - 銅層數目越多對散熱越有幫助，建議 6 層板以上
 - 與 LED 底部 pad 導通之銅層覆蓋面積越大越好，建議 80mm² 以上。
- 導熱孔設計
 - 數量越多對散熱越有好处，建議 30 個以上。
 - 直徑尺寸約 0.45-0.55mm 左右
 - 導熱孔須貫通第一層到最後一層。
- 建議操作條件
 - 依照其他手機廠家設計方式，建議貴司 follow 以下操作條件
 - 預閃電流: max 100mA
 - 預閃時間: max 600ms
 - 主閃電流: max 450-500mA
 - 主閃時間: max 250ms
 - 休息時間: min. 3000ms

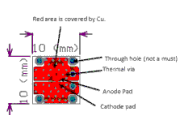

Forward Voltage vs. Forward Current, T_{soldering} = 25°C

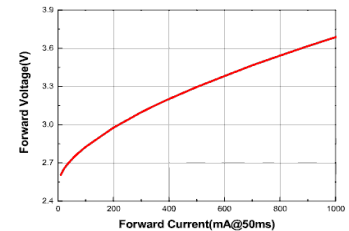

Ubiquicon Technology, Inc.
4FL, No. 300, Yang Guang St., Neihu
114 TAIPEI, TAIWAN, R.O.C.
(886-2)8751-6008

File	TomCat-U I12G00	
Size	Document Number	Rev
C	11. OMAP4-Camera_5M/1.2M	0.2
Date:	Wednesday, December 26, 2012	Sheet 11 of 30

OMAP -Audio

Audio Codec

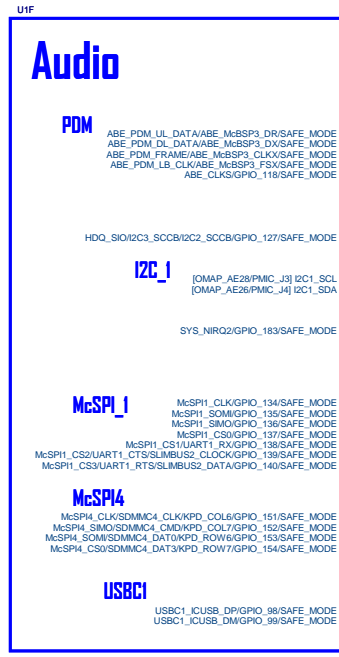

ATN081US 8GBIT

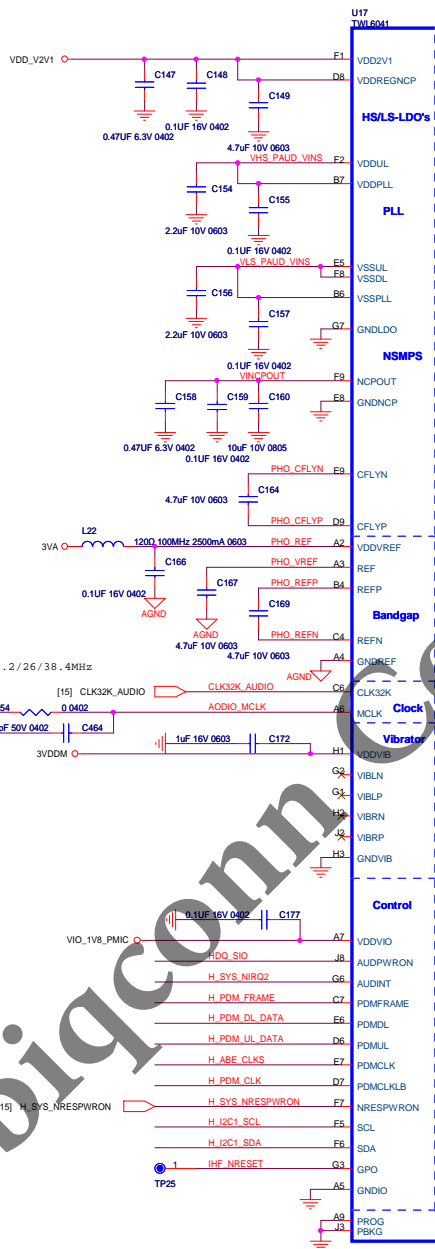
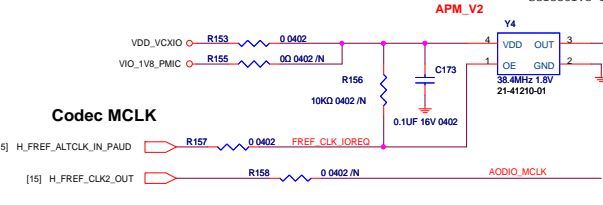

05-24195-01

VHS_PAUD_VINS: F2, B7, H8, C8
VLS_PAUD_VINS: F8, F5, B6, C9, G8

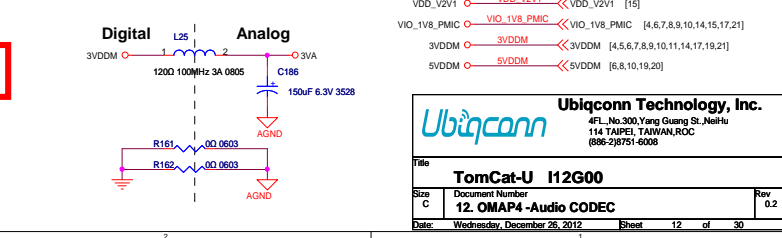
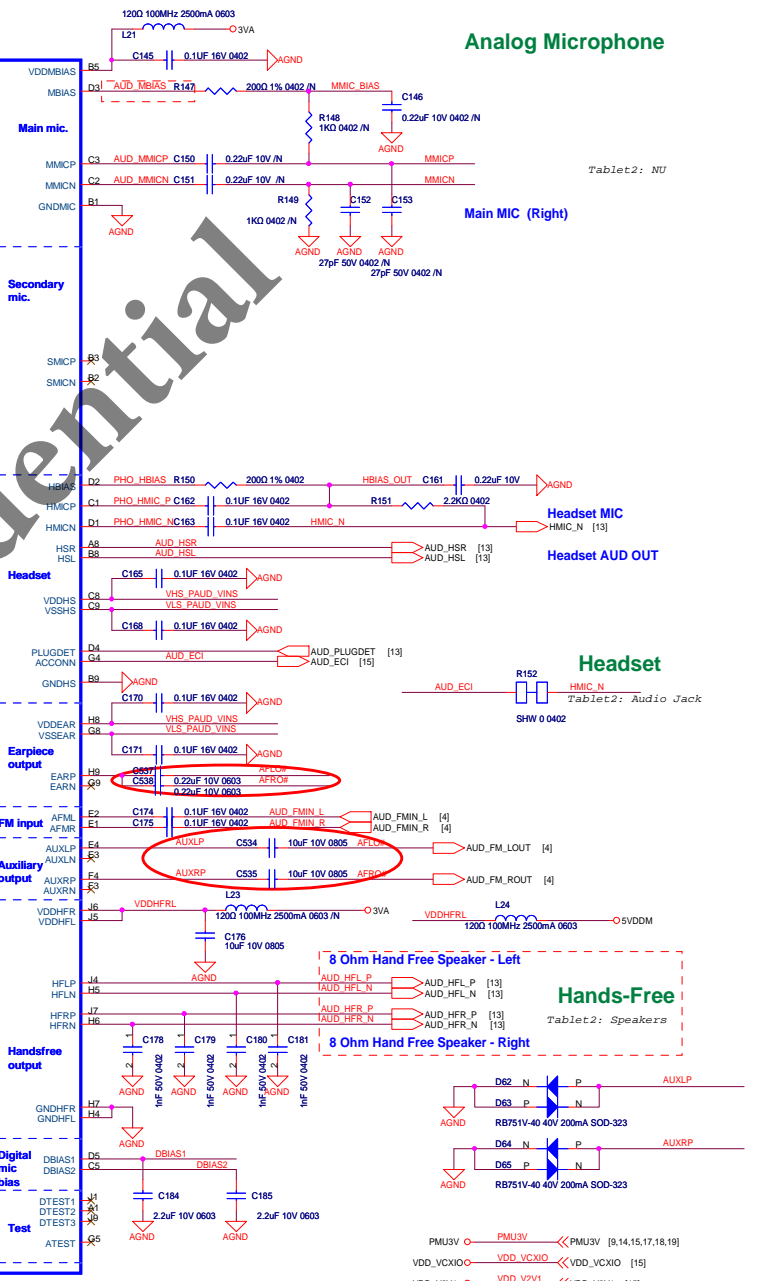

Ubiquiconn Technology, Inc.
4FL No.300, Yang Guang St., Neihu
114 Taipei, Taiwan, ROC
(886-2)8751-6008

TomCat-U I12G00

Document Number: **12. OMAP4 -Audio CODEC**

Date: Wednesday, December 26, 2012 Sheet: 12 of 30

Headset Audio Jack

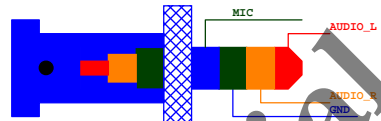
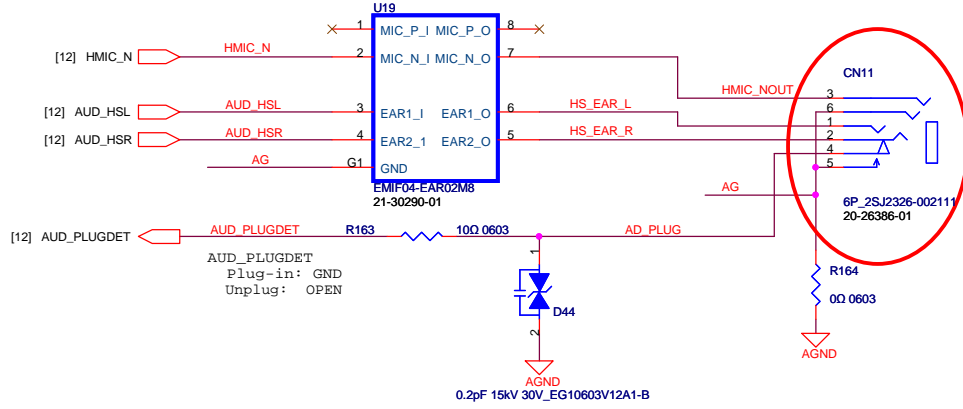

4 Polarity 3.5mm mini Jack

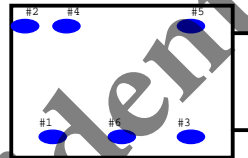

	JACK IN	JACK OUT
#1	AUDIO_L	
#2	AUDIO_R	
#3	MIC	
#4	PLUGDET	OPEN
#5	#4,#5 Short	OPEN
#6	GND	

4 Ohm Hands-Free Stereo Speakers

follow Elija P/N define, need check speaker+/- again

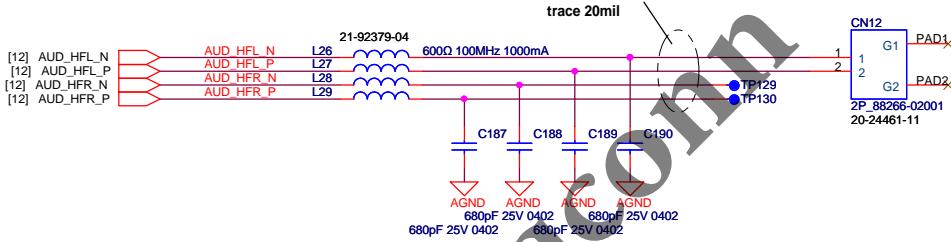

3VDDM << 3VDDM [4,5,6,7,8,9,10,11,12,14,17,19,21]
 VIO_1V8_PMIC << VIO_1V8_PMIC [4,6,7,8,9,10,12,14,15,17,21]

Ubiqonn Confidential

Ubiqonn Technology, Inc.
 4FL_No.300, Yang Guang St., NeiHu
 114 TAIPEI, TAIWAN, ROC
 (886-2)8751-6008

Title: **TomCat-U I12G00**

Size B Document Number: **13. Audio JACK/MIC/SPK** Rev 0.2

Date: Wednesday, December 26, 2012 Sheet 13 of 30

OMAP -IOs

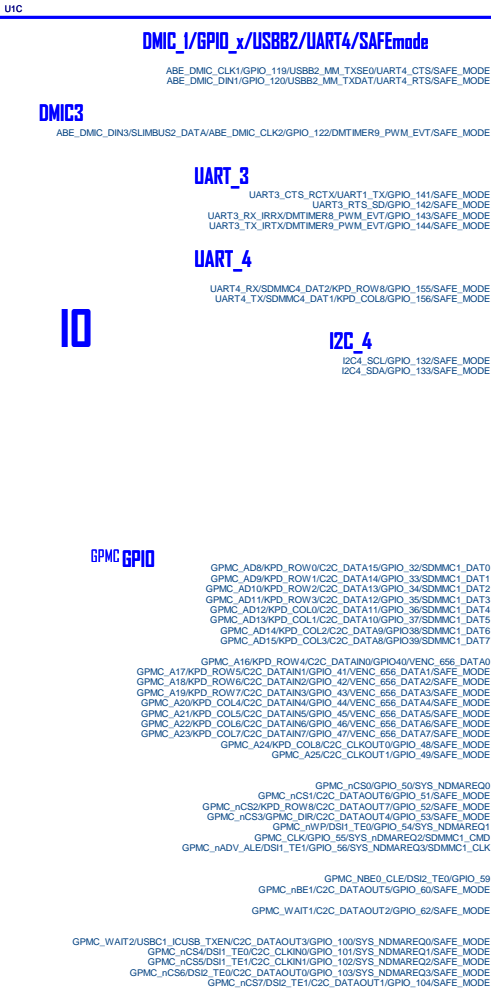

ATNC081J5 8GBIT

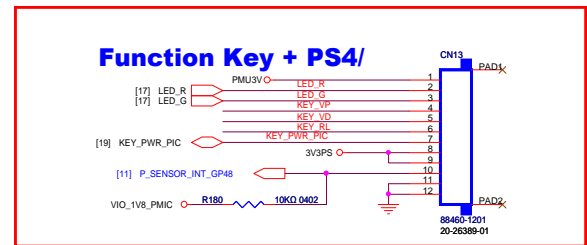
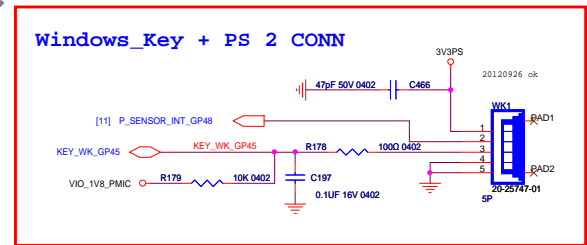
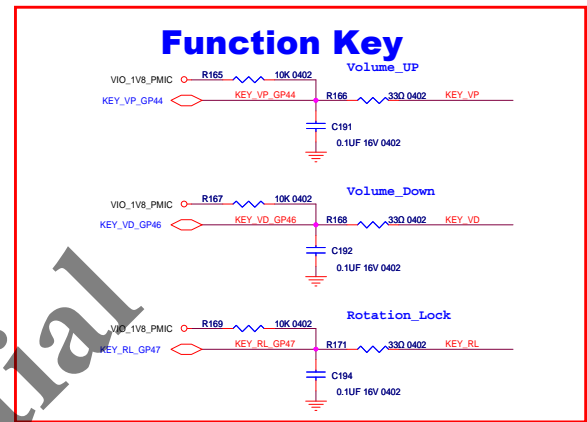
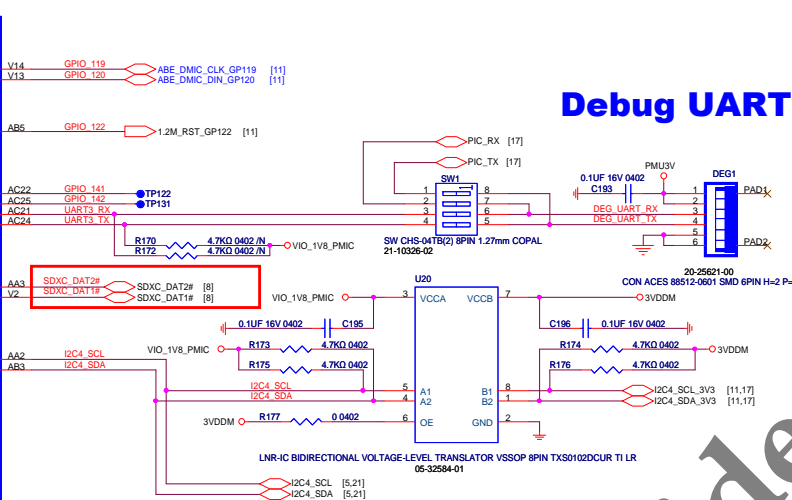

Ubiquiconn Technology, Inc.
4F, No.300, Yang Guang St., NeiHu
114 Taipei, TAIWAN, R.O.C.
(886-2)8751-6008

Ubiquiconn

File: **TomCat-U I12G00**
Size C Document Number: **14. OMAP4 -IOs/KEY** Rev 0.2
Date: **Wednesday, December 26, 2012** Sheet 14 of 30

OMAP -System

U1G

PLL



RTCOUT

PWRCTRL

BTN ctrl system ON/OFF (short/long/very-long press)
 ON/OFF or Peripherals could initial WARM reset to PMIC
 PMIC release after all rails ready

JTAG

OTG

BOOTMODE

VBAT

PMIC's Power-on reset (POR) is triggered when main battery and backup battery voltages are low. This condition activates a POR that remains active until a valid energy source is detected. The POR release initiates the boot sequence of the TWL6032 device.

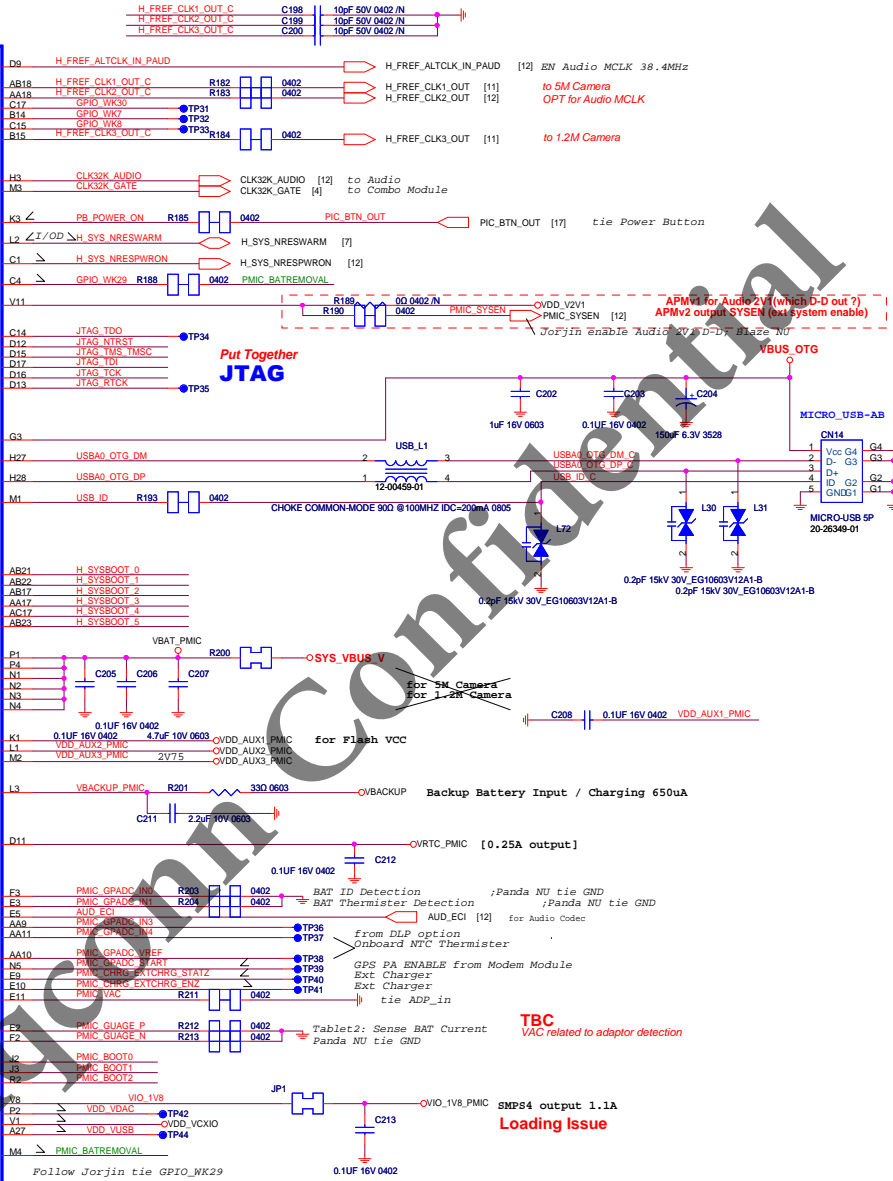

Debug Only

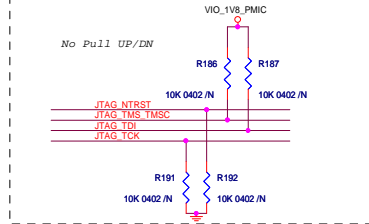
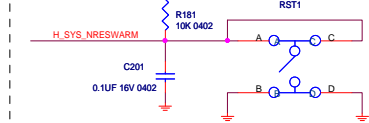

OMAP BOOT Selection

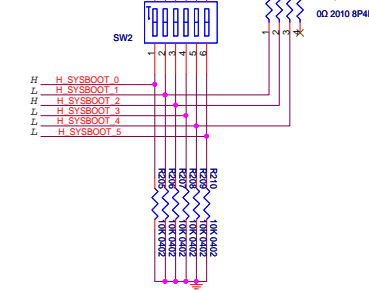

ext uSD (MMC1) Priority: ON OFF ON OFF ON X X
 eMMC/SD (MMC2) Priority: OFF OFF OFF OFF OFF ON X X

PMIC Power-up Sequence Selection

PMIC_BOOT[2:0] = 000

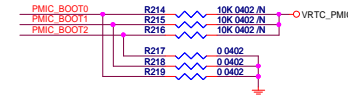

Ubiqconn Technology, Inc.
 4FL No.300, Yang Guang St., Neihu
 114 TAIPEI, TAIWAN, R.O.C.
 (886-2)8751-6008

Title		TomCat-U I12G00	
Size C		Document Number 15. OMAP4-SYS/PMIC	
Date		Wednesday, December 26, 2012	
Sheet		15 of 30	
Rev		0.2	

- VDD_VDAC = 1.8V
- VDD_VCXIO = 1.8V
- VDD_VUSB = (OTG OFF = 0V OTG ON TO PC 3.3V USB_ID = 3.3V)
- VDD_RTC = 1.8V
- VDD_AUX1_PMIC = 2.75V
- VDD_AUX2_PMIC = 2.75V
- VDD_AUX3_PMIC = 2.75V
- vbus_oto = vbus_oto
- sys_vbus_v = sys_vbus_v
- sys_vbus = sys_vbus

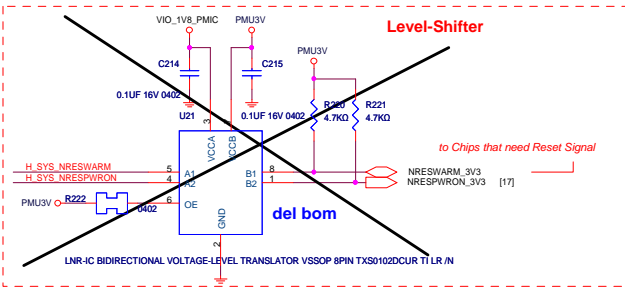
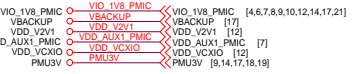
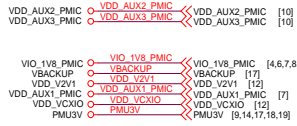

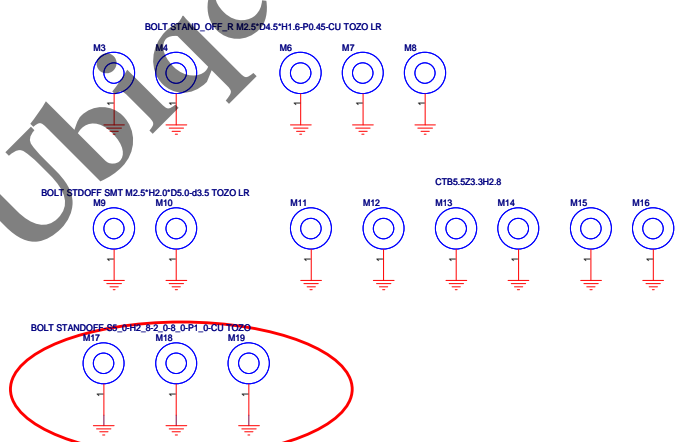
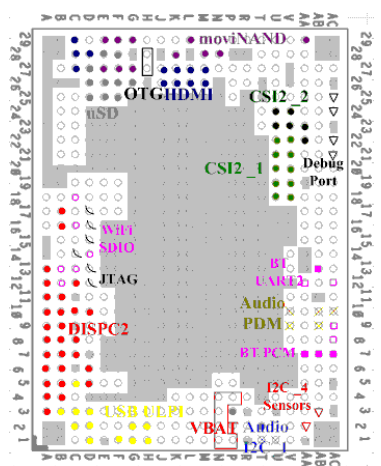
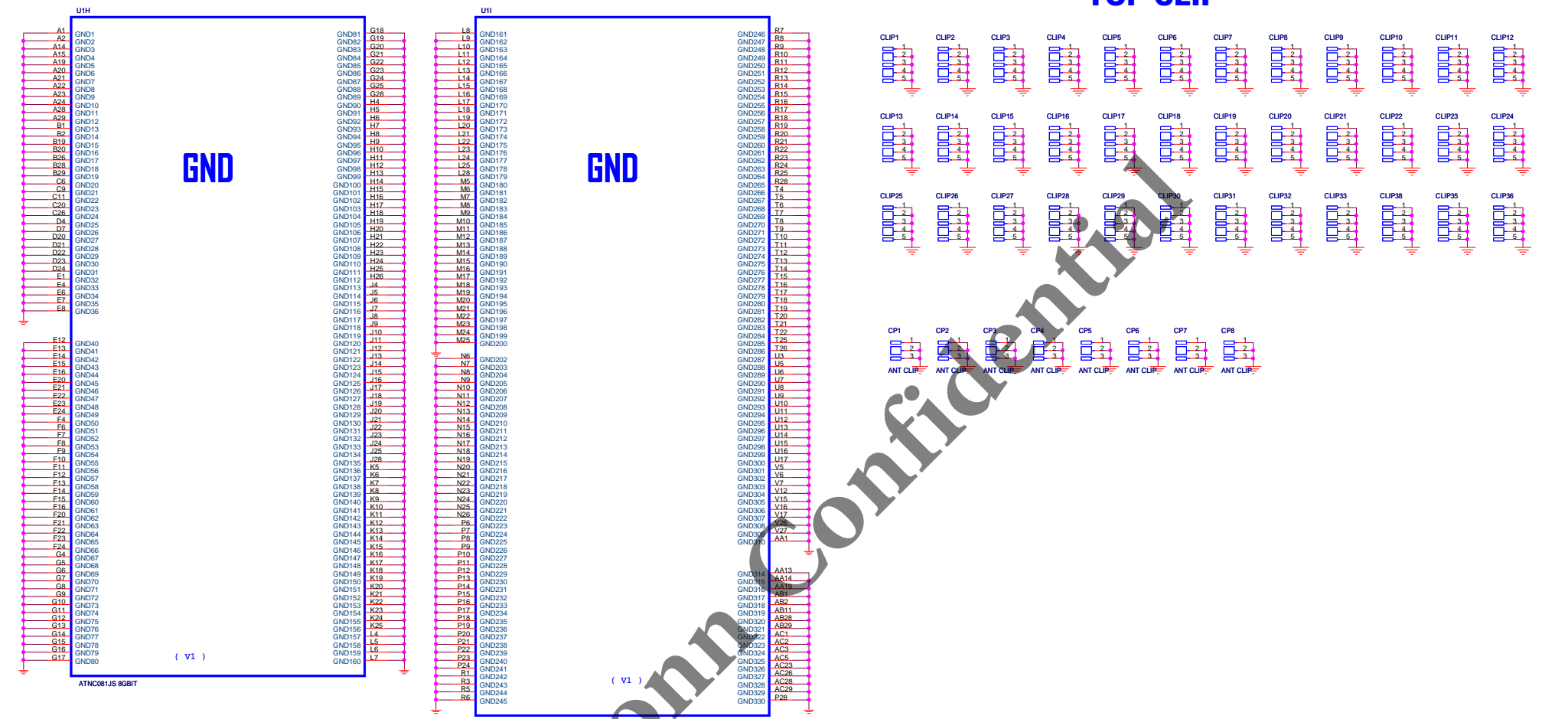

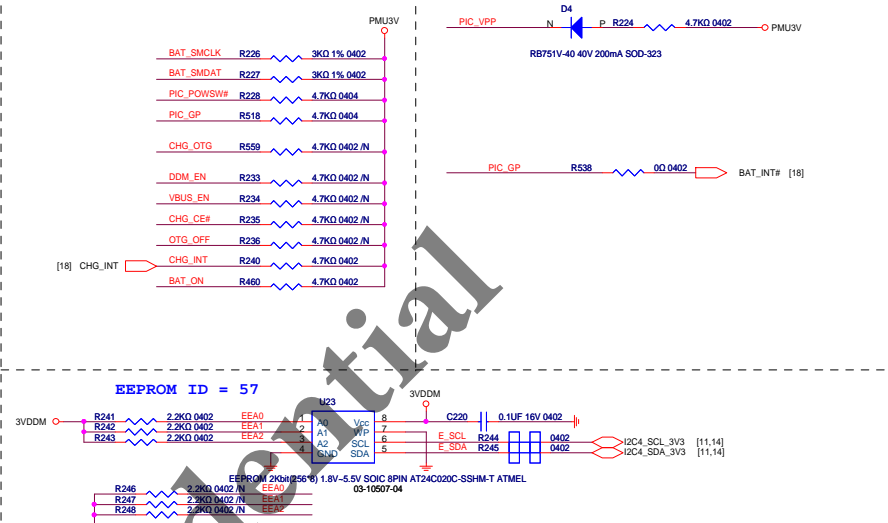
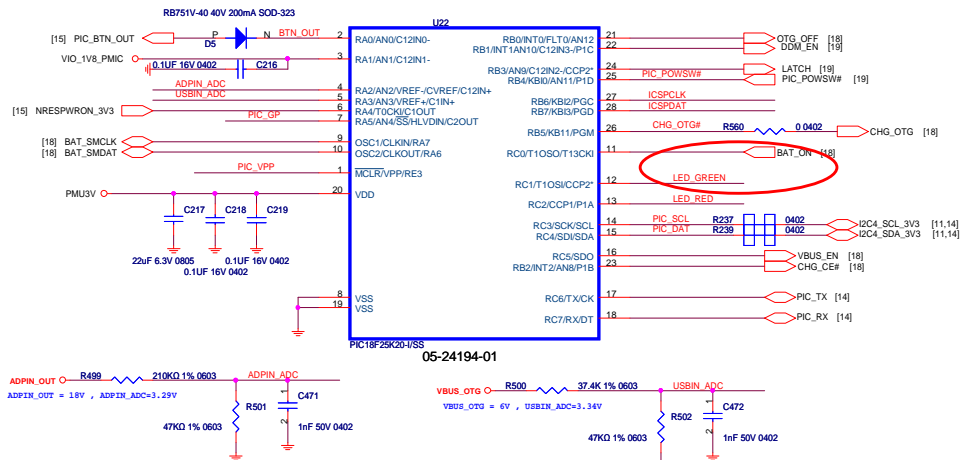

PowerLED

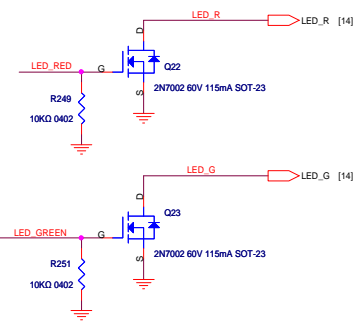

RTC_BAT

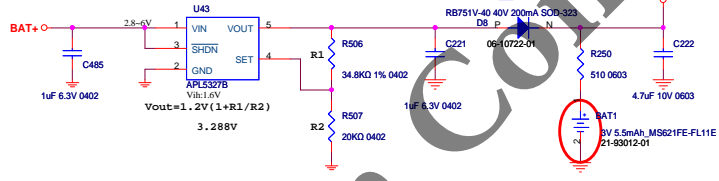

Program Connector

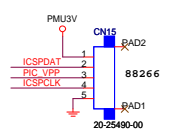
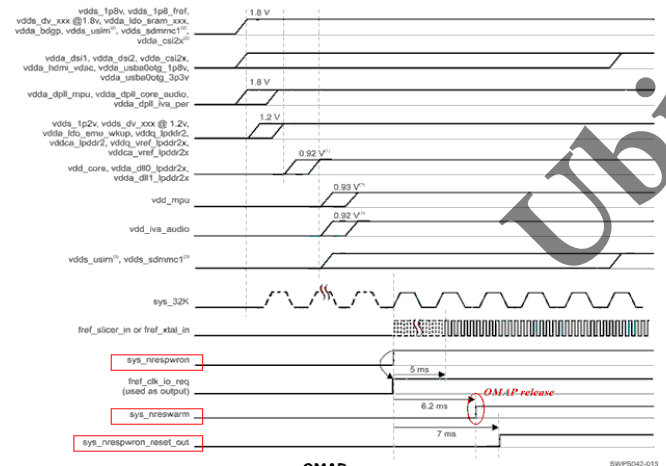
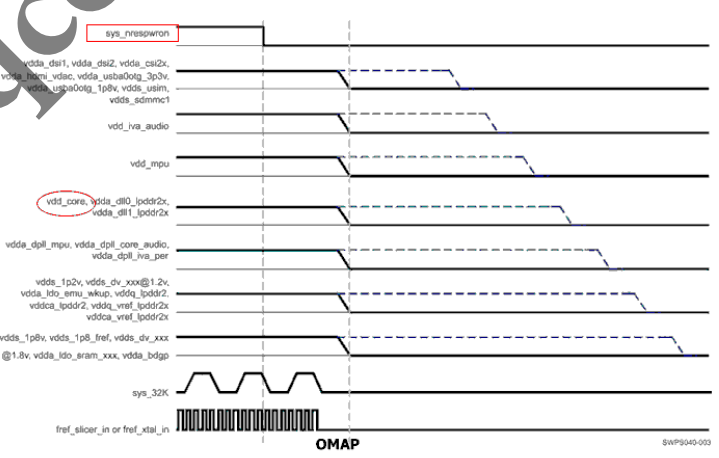

Figure 3-8 shows the power-up sequence.



OMAP
Figure 3-8. Power-Up Sequence



OMAP
Figure 3-9. Power-Down Sequence

- ADPIN_OUT O ADPIN_OUT << ADPIN_OUT [18,19]
- VBUS_OTG O VBUS_OTG << VBUS_OTG [15,18,19]
- BAT+ O BAT+ << BAT+ [18]
- ADPIN O ADPIN << ADPIN [18]
- VIO_1V8_PMIC O VIO_1V8_PMIC << VIO_1V8_PMIC [4,6,7,8,9,10,12,14,15,21]
- VBACKUP O VBACKUP << VBACKUP [15]
- PMU3V O PMU3V << PMU3V [9,14,15,18,19]
- 3VDDM O 3VDDM << 3VDDM [4,5,6,7,8,9,10,11,12,14,19,21]
- 5VDDM O 5VDDM << 5VDDM [6,8,10,12,19,20]
- DCIN+ O DCIN+ << DCIN+
- ADPIN O ADPIN << ADPIN [18]

Ubiqconn Technology, Inc.
4FL No.300 Yang Guang St. XueHu
114 Taipei, TAIWAN,RCC
(886-2)8751-6008

TomCat-U I12G00
17. PIC Control/VRTC

Rev 0.2
Date: Wednesday, December 26, 2012 Sheet 17 of 30

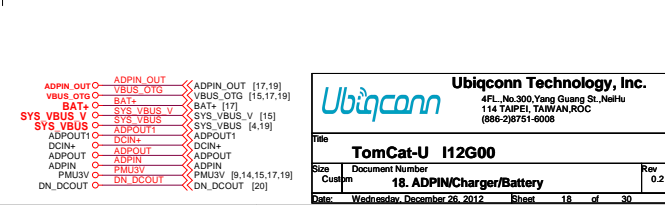
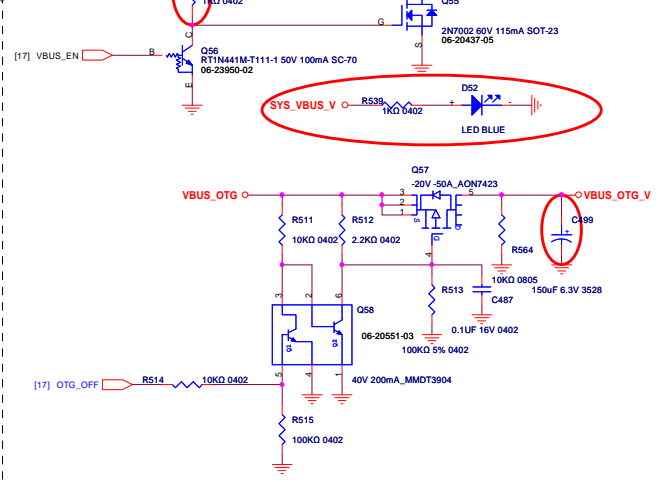
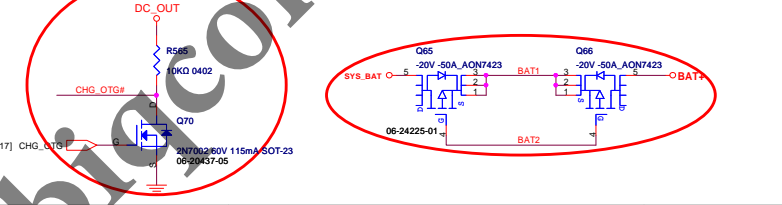
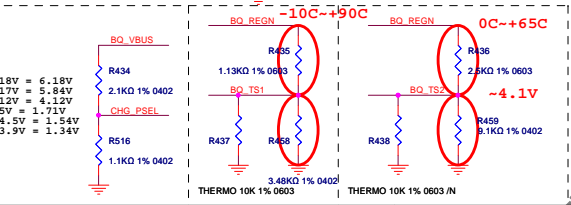
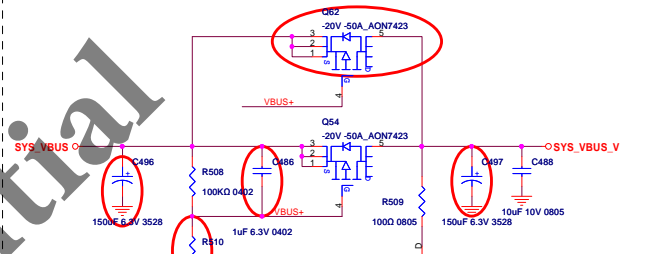
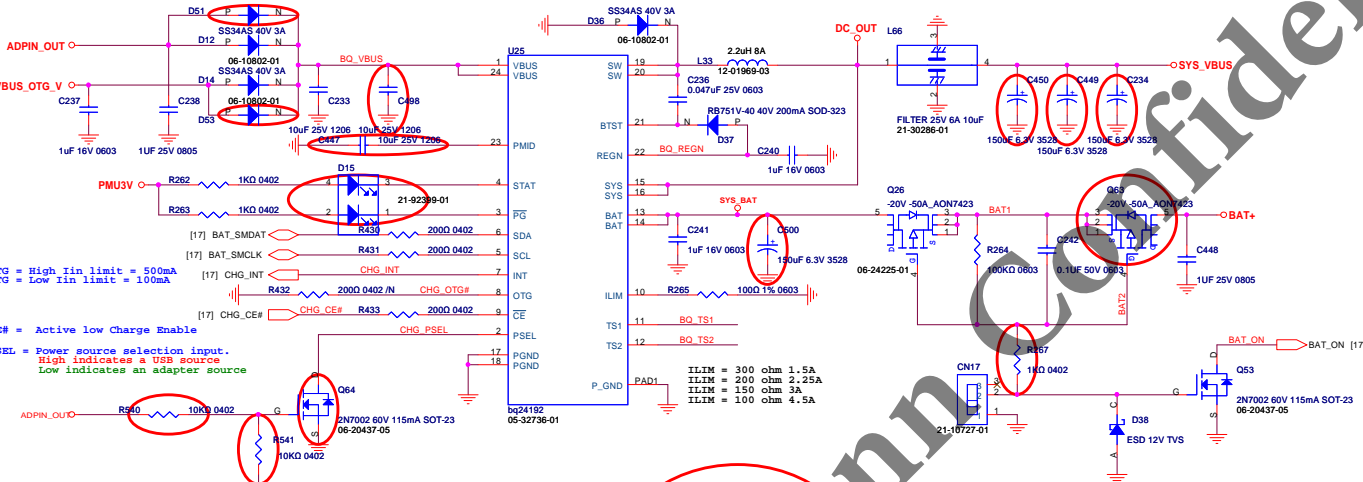
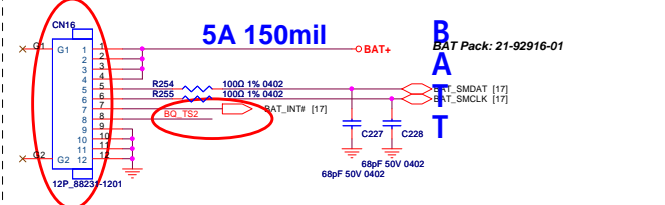
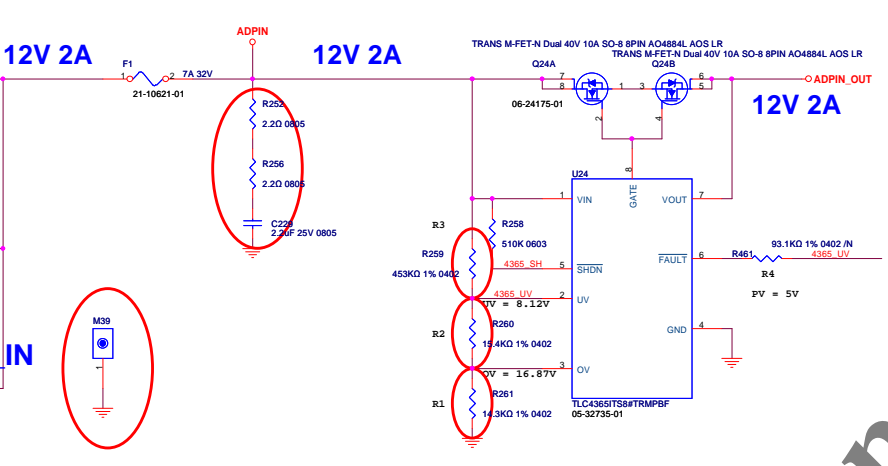
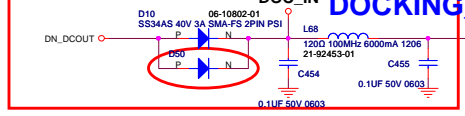
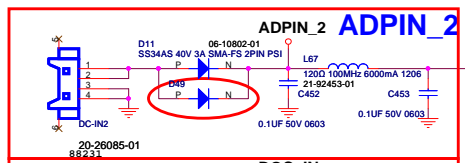
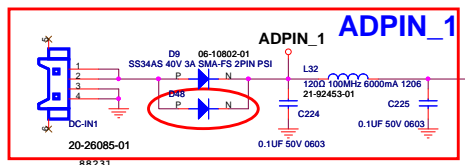

Ubiconn Technology, Inc.
 4FL, No.300, Yang Guang St., Neihu
 114 TAIPEI, TAIWAN, ROC
 (886-2)8751-0008

Ubiconn

TomCat-U H2G00

Size: Custom Document Number: 18. ADPIN/Charger/Battery Rev: 0.2

Date: Wednesday, December 26, 2012 Sheet: 18 of 30

PMU3V, 5VDDM, 3VDDA, 3VDDM SYSTEM 1.8VDDM

5VDDM

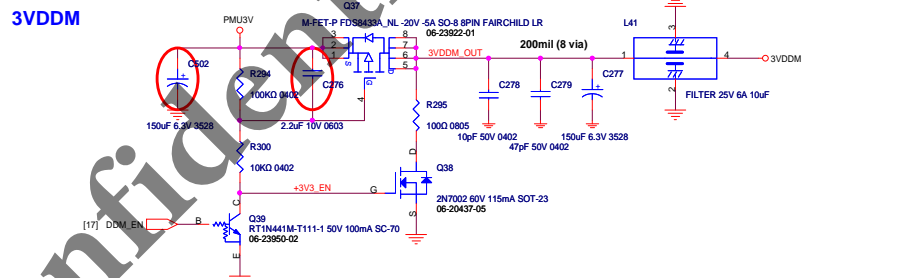
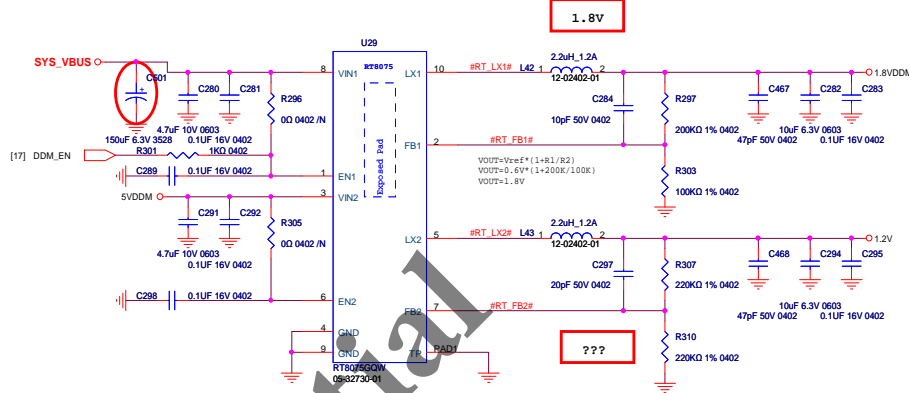
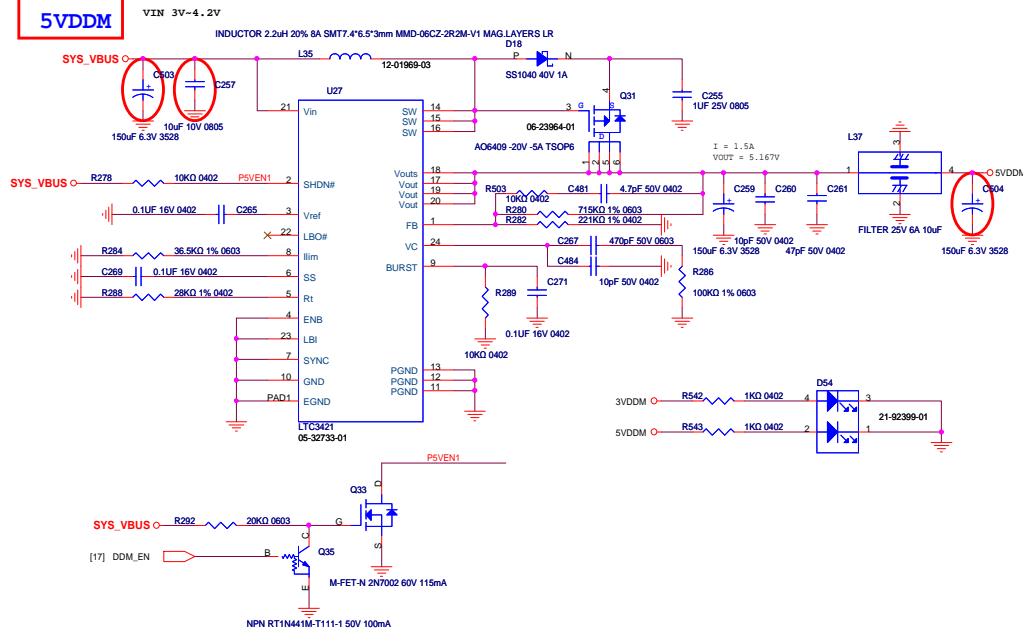

PMU3V

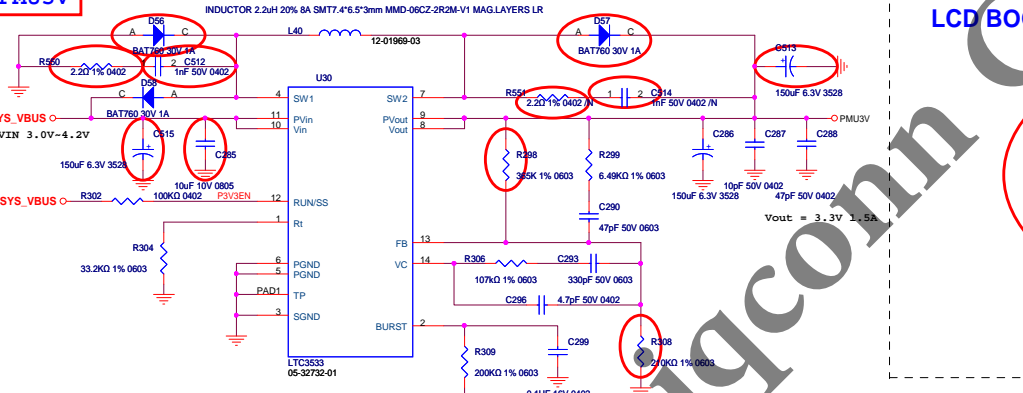

LCD BOOST 12V

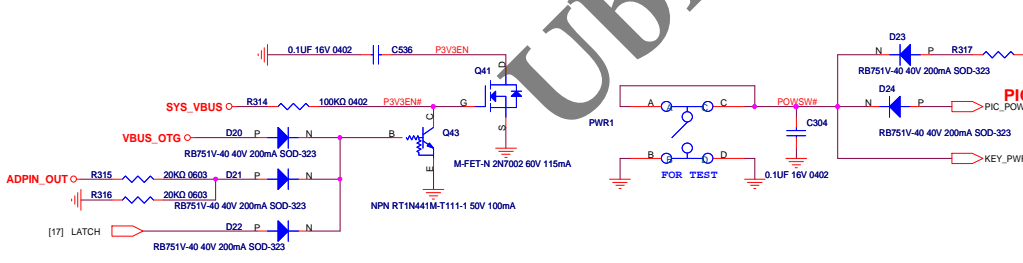
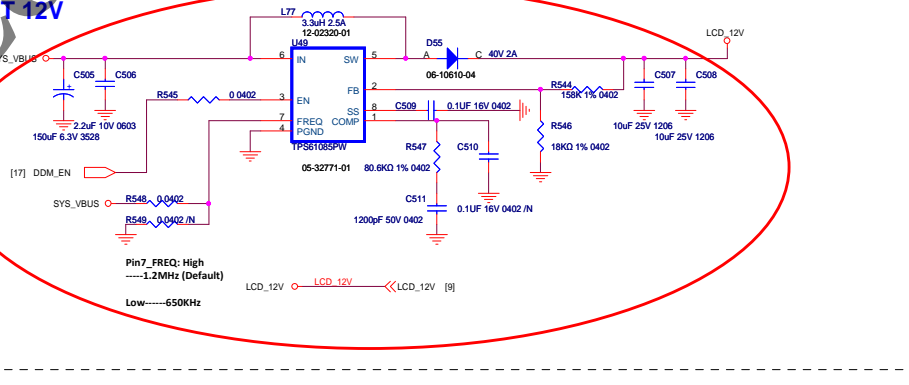

P_Sensor POWER

Min : 80 MIL or Power Plane

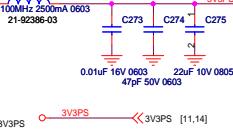

- ADPIN_OUT <-> ADPIN_OUT <-> ADPIN_OUT [17,18]
- VBUS_OTG <-> VBUS_OTG <-> VBUS_OTG [15,17,18]
- SYS_VBUS <-> SYS_VBUS <-> SYS_VBUS [4,18]
- 1.8VDDM <-> 1.8VDDM <-> 1.8VDDM [4,5,10,11]
- ADPOUT1 <-> ADPOUT1 <-> ADPOUT1
- PMU3V <-> PMU3V <-> PMU3V [8,14,15,17,18]
- 3VDDM <-> 3VDDM <-> 3VDDM [4,5,6,7,8,9,10,11,12,14,17,21]
- 5VDDM <-> 5VDDM <-> 5VDDM [6,8,10,12,20]
- VIO_1V8_PMIC <-> VIO_1V8_PMIC <-> VIO_1V8_PMIC [4,6,7,8,9,10,12,14,15,17,21]

Ubiquconn Technology, Inc.
4F, No. 300, Yang Guang St., Neihu
114, TAIPEI, TAIWAN, R.O.C.
(886-2)8751-6008

Title: TomCat-U H2G00		
Size: 19.3/5VDDA/M	Document Number: 19.3/5VDDA/M	Rev: 0.2
Date: Friday, January 04, 2013	Sheet: 19	of 30

USB Ports to uwb

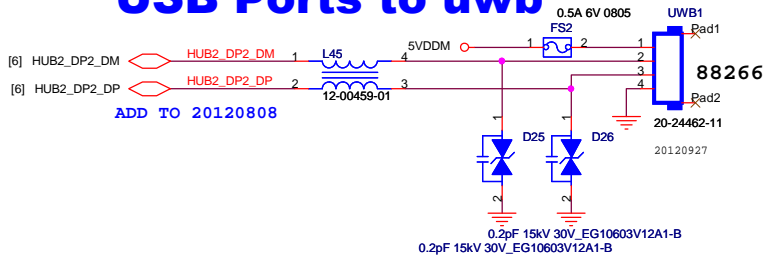

USB Ports to Smart card

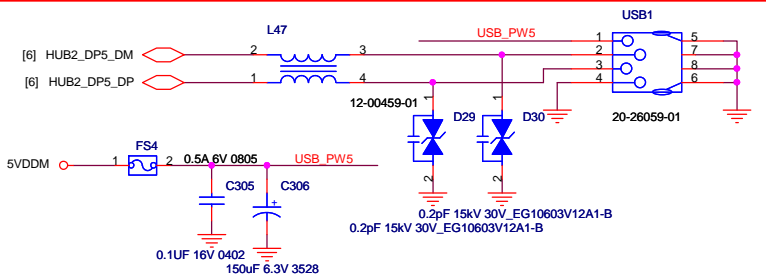
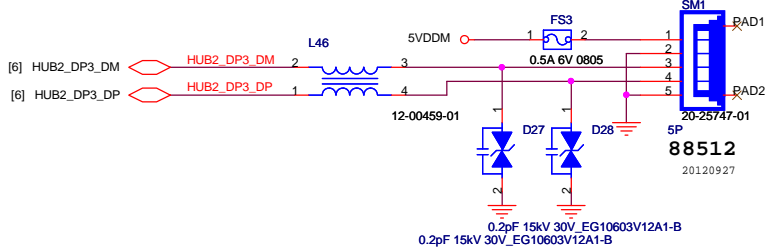

USB Ports to DOCKING

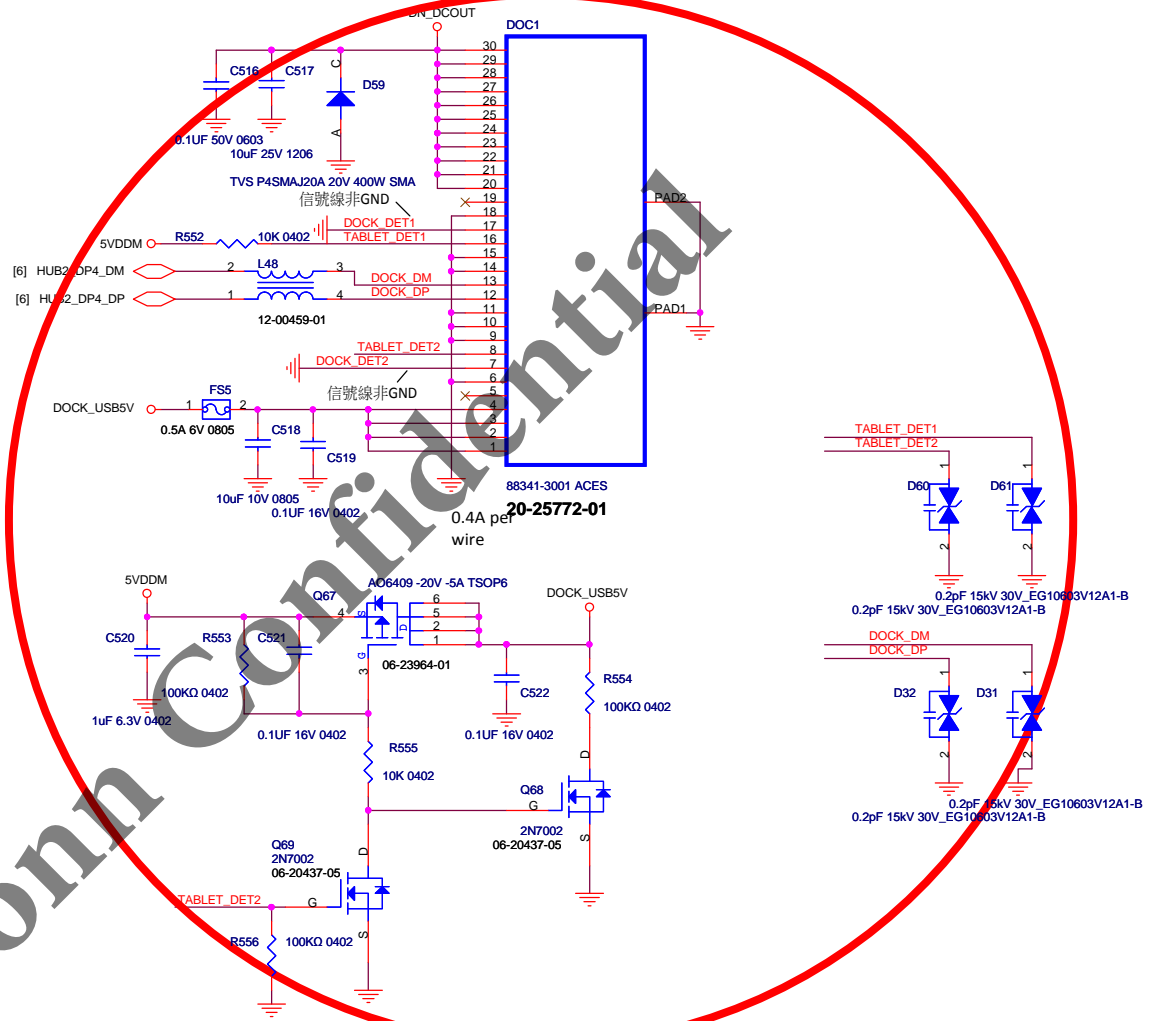

3VDDM ○ 3VDDM ↔ 3VDDM [4,5,6,7,8,9,10,11,12,14,17,19,21]
 5VDDM ○ 5VDDM ↔ 5VDDM [6,8,10,12,19]
 DN_DCOUT ○ DN_DCOUT ↔ DN_DCOUT [18]

Ubiqconn Technology, Inc.
 4FL_No.300,Yang Guang St.,NeiHu
 114 TAIPEI, TAIWAN,ROC
 (886-2)8751-6008

Ubiqconn

Title: **TomCat-U I12G00**

Size B Document Number: **22. Ext USB CONN / CLIP** Rev 0.2

Date: Wednesday, December 26, 2012 Sheet 20 of 30

G-SENSOR

重力感測器

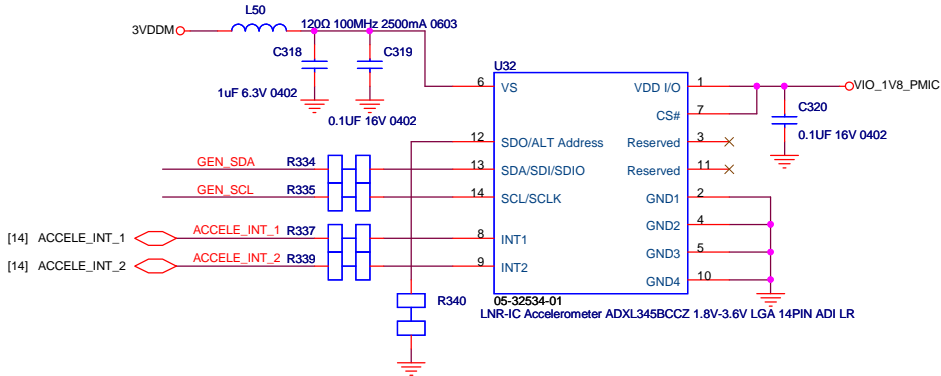

E-COMPASS

電子羅盤

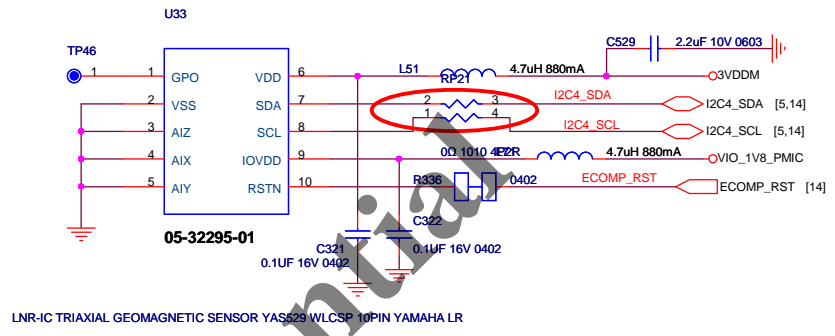

Gyroscope

陀螺儀

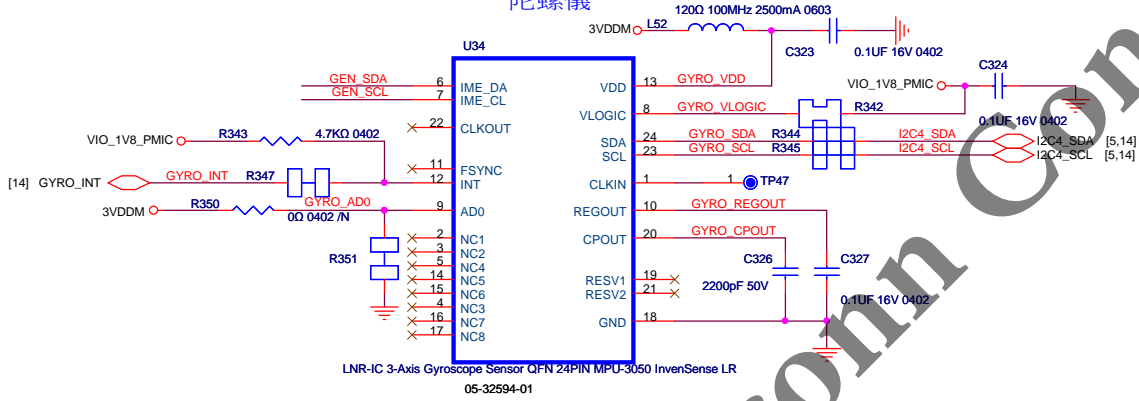

E-COMPASS

電子羅盤

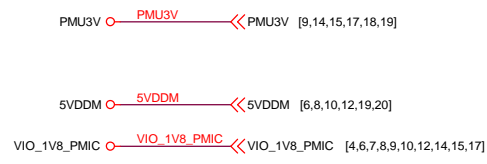
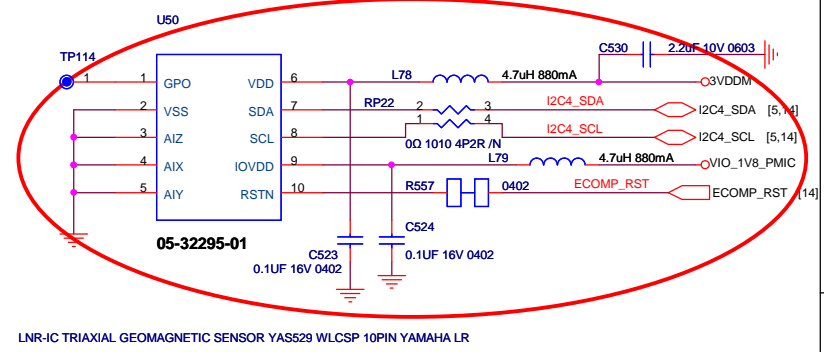

Ubiqconn Technology, Inc.
 4FL_No.300, Yang Guang St., NeiHu
 114 TAIPEI, TAIWAN, ROC
 (886-2)8751-6008

TomCat-U I12G00

Size B Document Number 21. SENSORS Rev 0.2

Date: Wednesday, December 26, 2012 Sheet 21 of 30

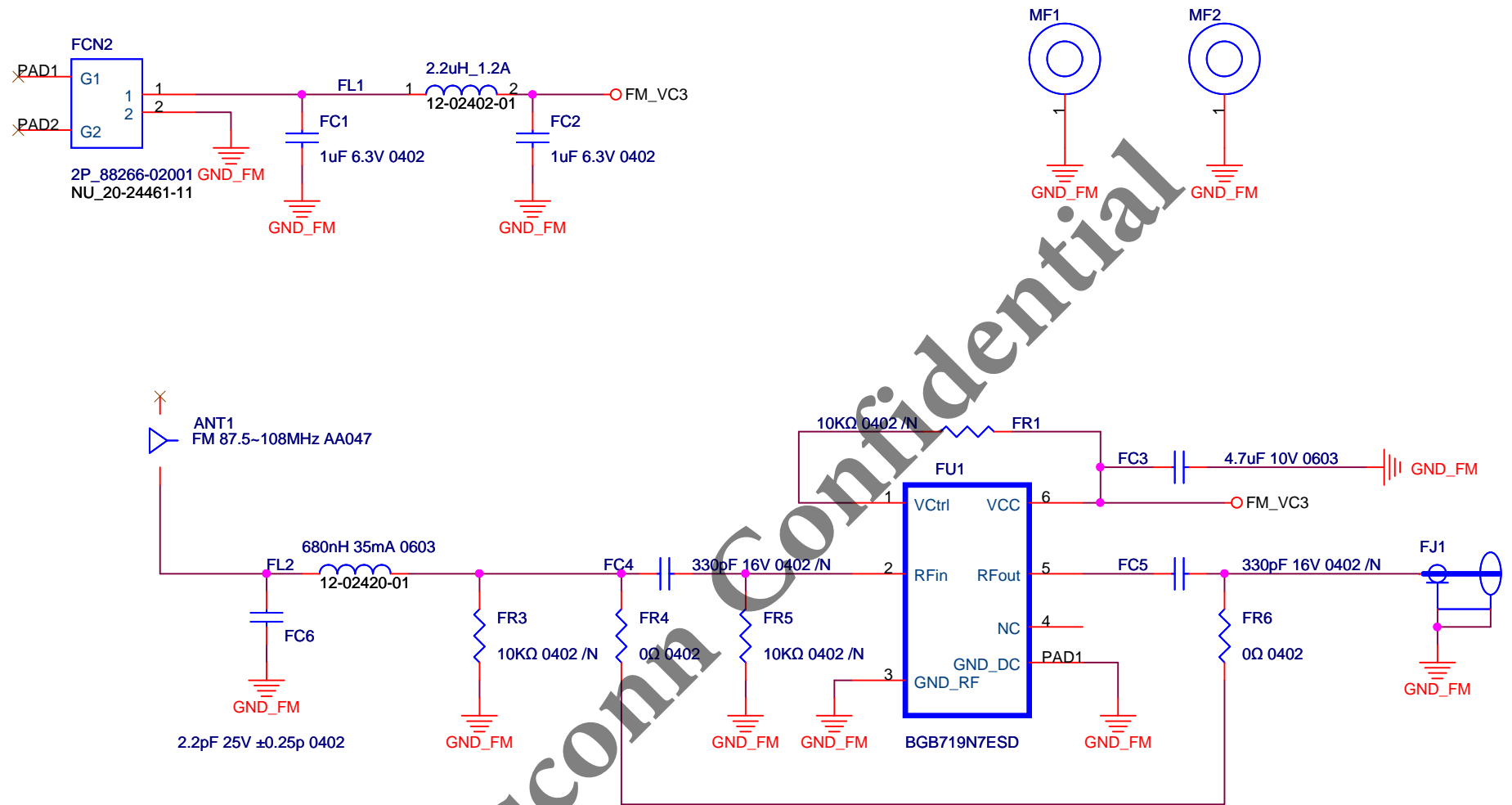

Ubiquconn Confidential

		Ubiquconn Technology, Inc.
4FL., No.300, Yang Guang St., NeiHu 114 TAIPEI, TAIWAN, ROC (886-2)8751-6008		
Title		
TomCat-U I12G00		
Size A	Document Number 22.FM TX BOARD	Rev 0.2
Date: Wednesday, December 26, 2012		Sheet 22 of 30

WIN Key + PS 2 Board

迫近感測器

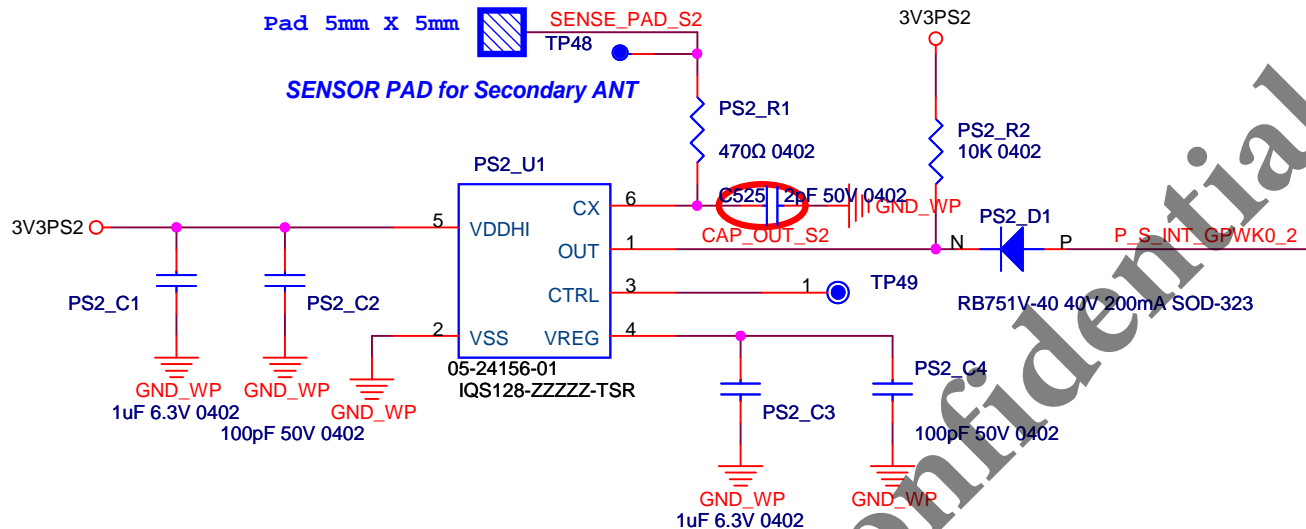

Proximity Sensor 2

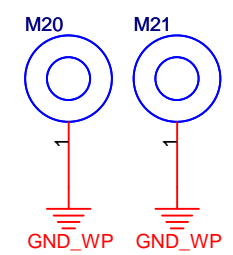

Windows Key

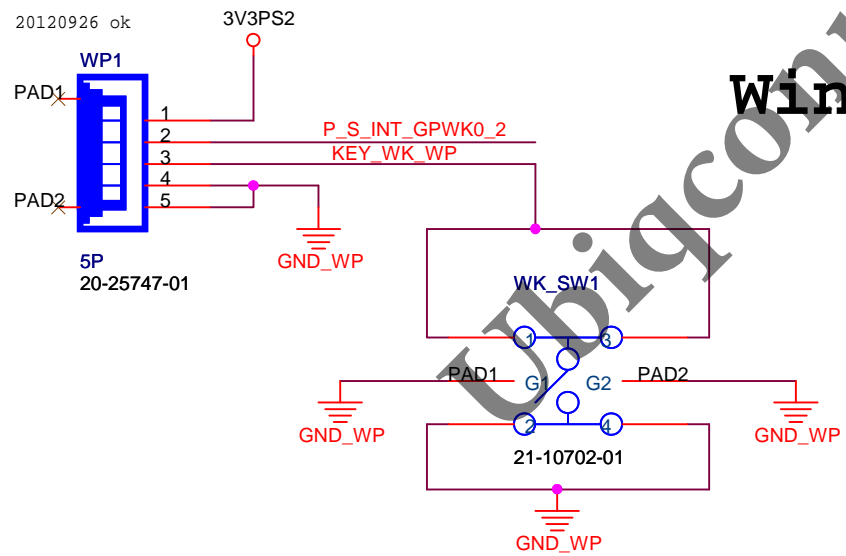

PCB P/N : 50-43042-21

		Ubiquconn Technology, Inc. 4FL.,No.300,Yang Guang St.,NeiHu 114 TAIPEI, TAIWAN,ROC (886-2)8751-6008	
		Title TomCat-U I12G00	
Size A	Document Number		Rev
	23. WK_Key + PS_2 Board		0.2
Date:	Wednesday, December 26, 2012	Sheet	23 of 30

1.2M Camera + PS 3 Board

迫近感測器

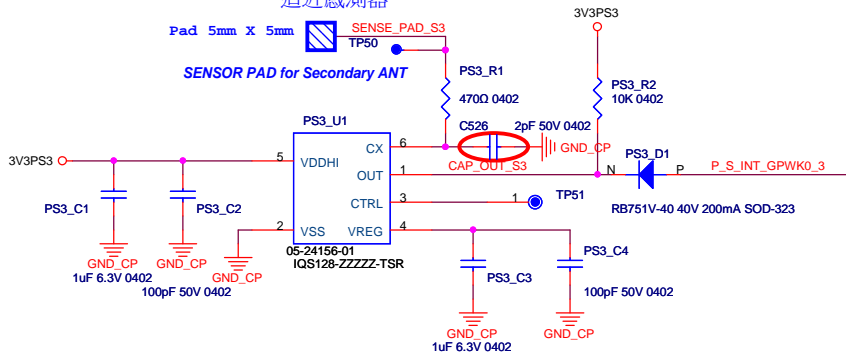

Proximity Sensor 3

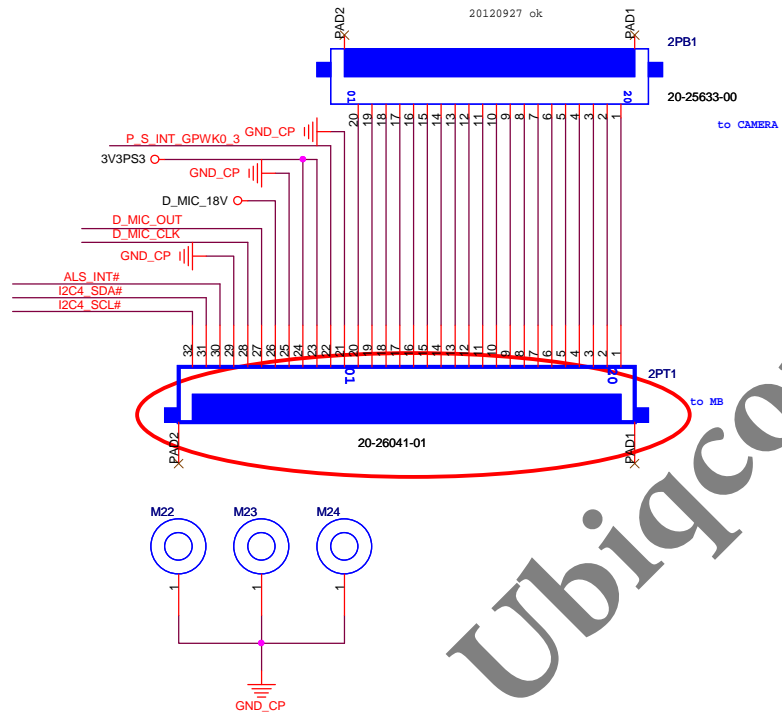
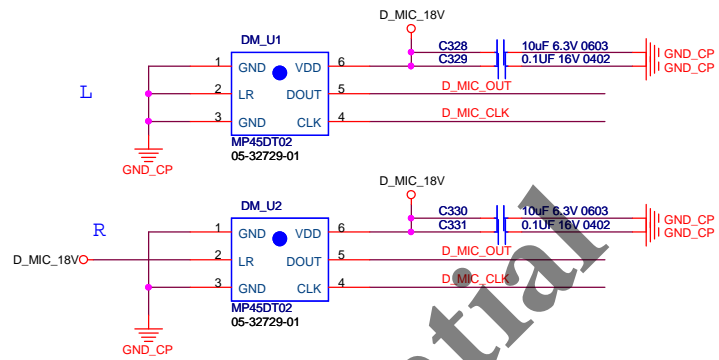

A-Light Sensor

光源感測器

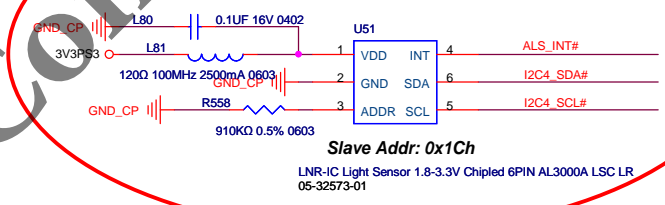

Ubiqconn Confidential

PCB P/N : 50-43043-21

Ubiqconn Technology, Inc.
 4FL_No.300, Yang Guang St., NeiHu
 114 TAIPEI, TAIWAN, ROC
 (886-2)8751-6008

Title		
TomCat-U I12G00		
Size	Document Number	Rev
B	24. 1.2M+DMIC_PS_3 Board	0.2
Date:	Wednesday, December 26, 2012	Sheet 24 of 30

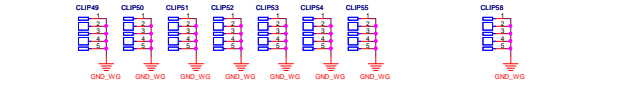
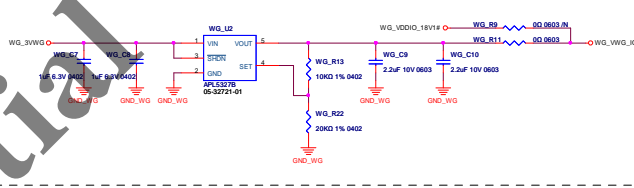
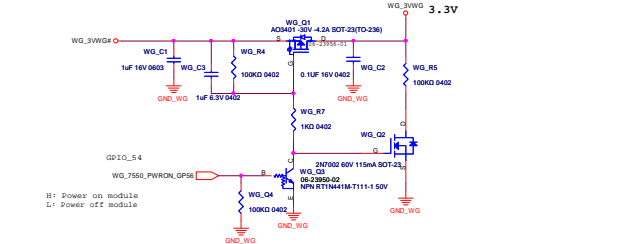
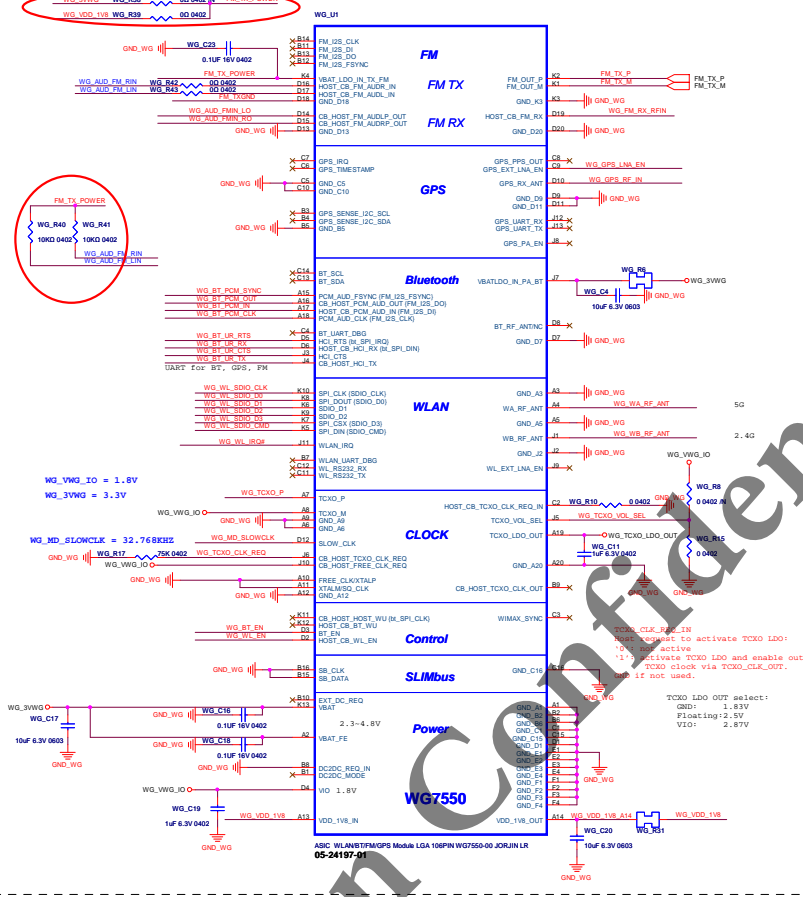
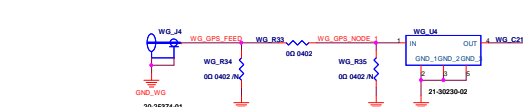
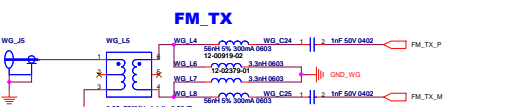
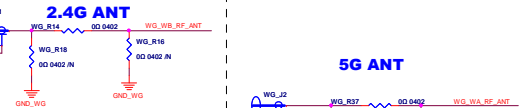
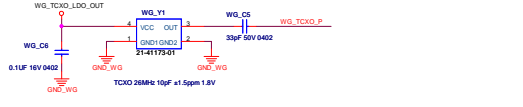
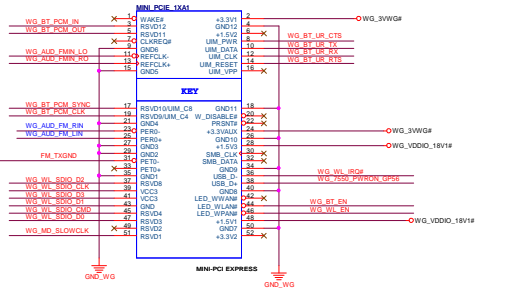

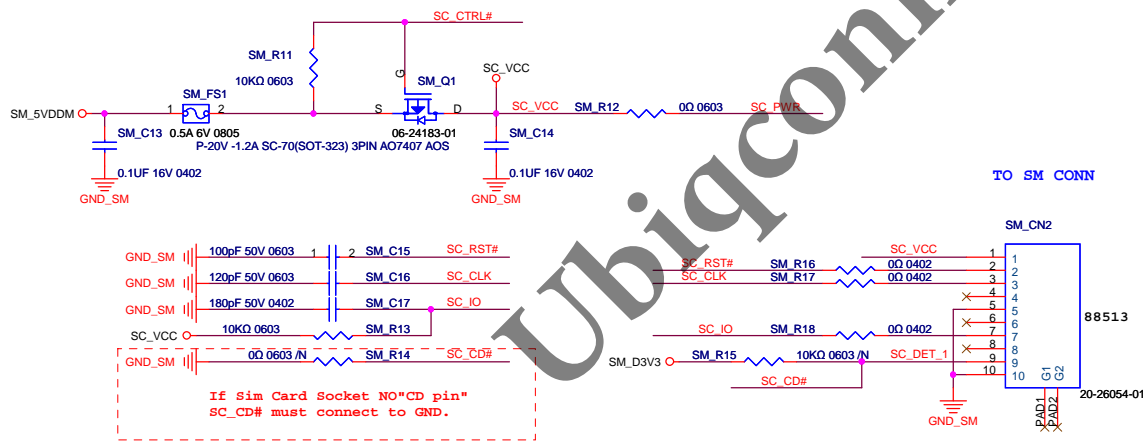
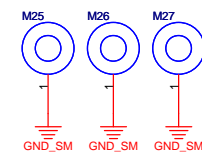
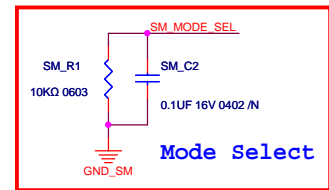
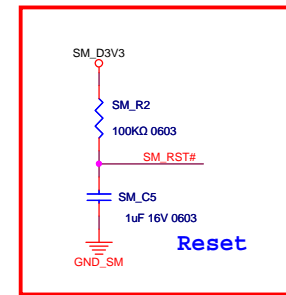
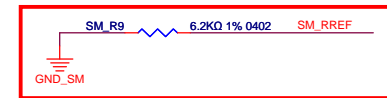
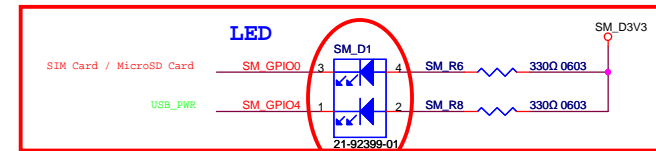
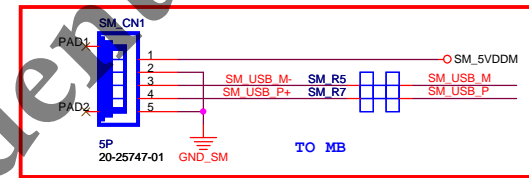
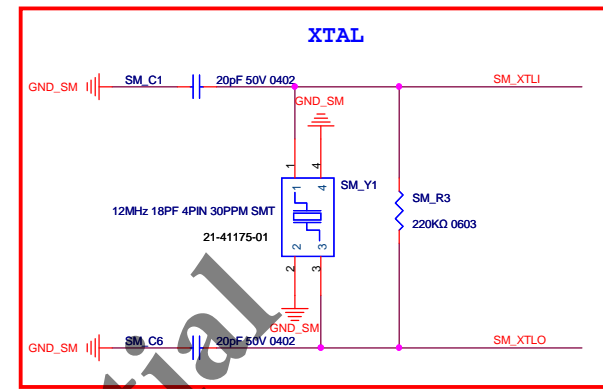
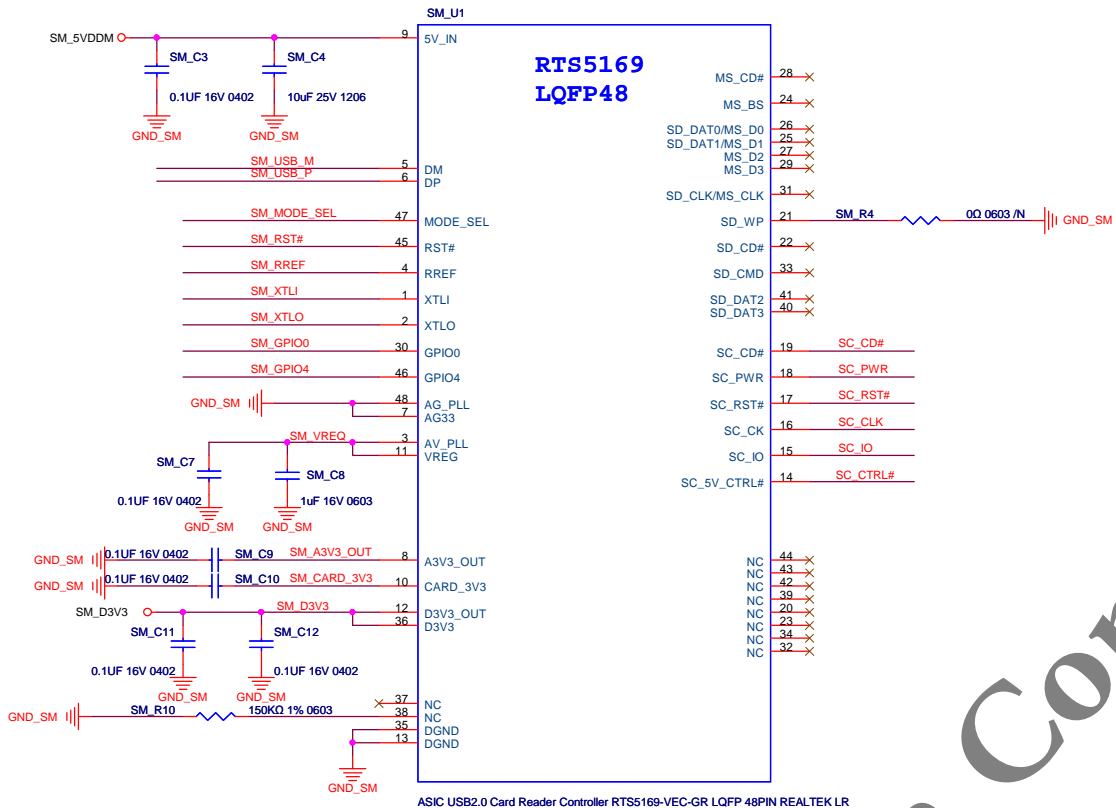

Function Key

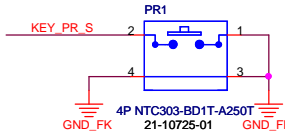
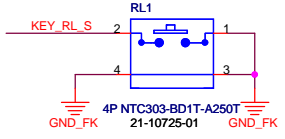
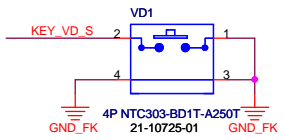
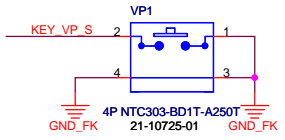

Proximity Sensor 4 / 1

追近感測器

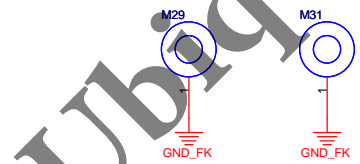
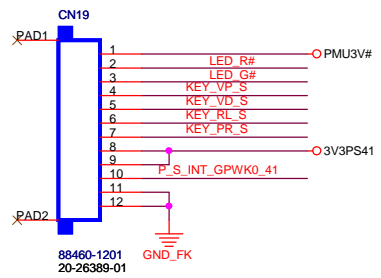
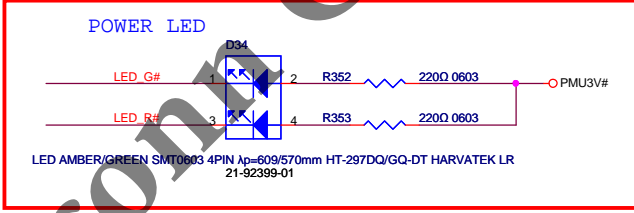
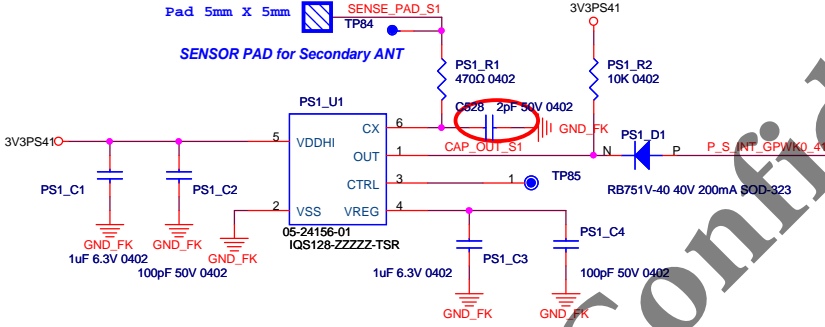
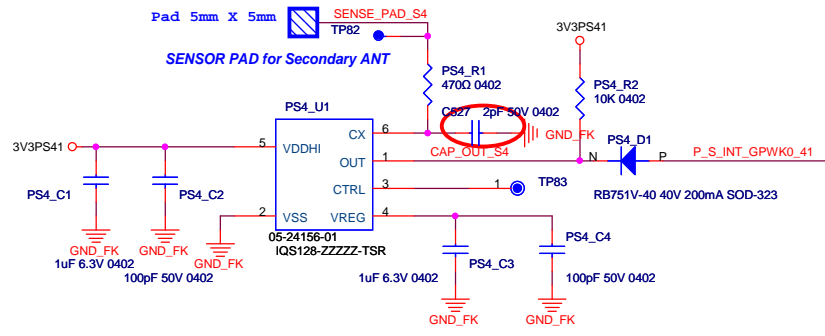

PCB P/N : 50-43046-21

Ubiquconn Technology, Inc.
 4FL, No.300, Yang Guang St., NeiHu
 114 TAIPEI, TAIWAN, ROC
 (886-2)8751-6008

Title		TomCat-U I12G00
Size	Document Number	Rev
B	27. FN_KEY+PS_1/4 BOARD	0.2
Date:	Wednesday, December 26, 2012	Sheet 27 of 30

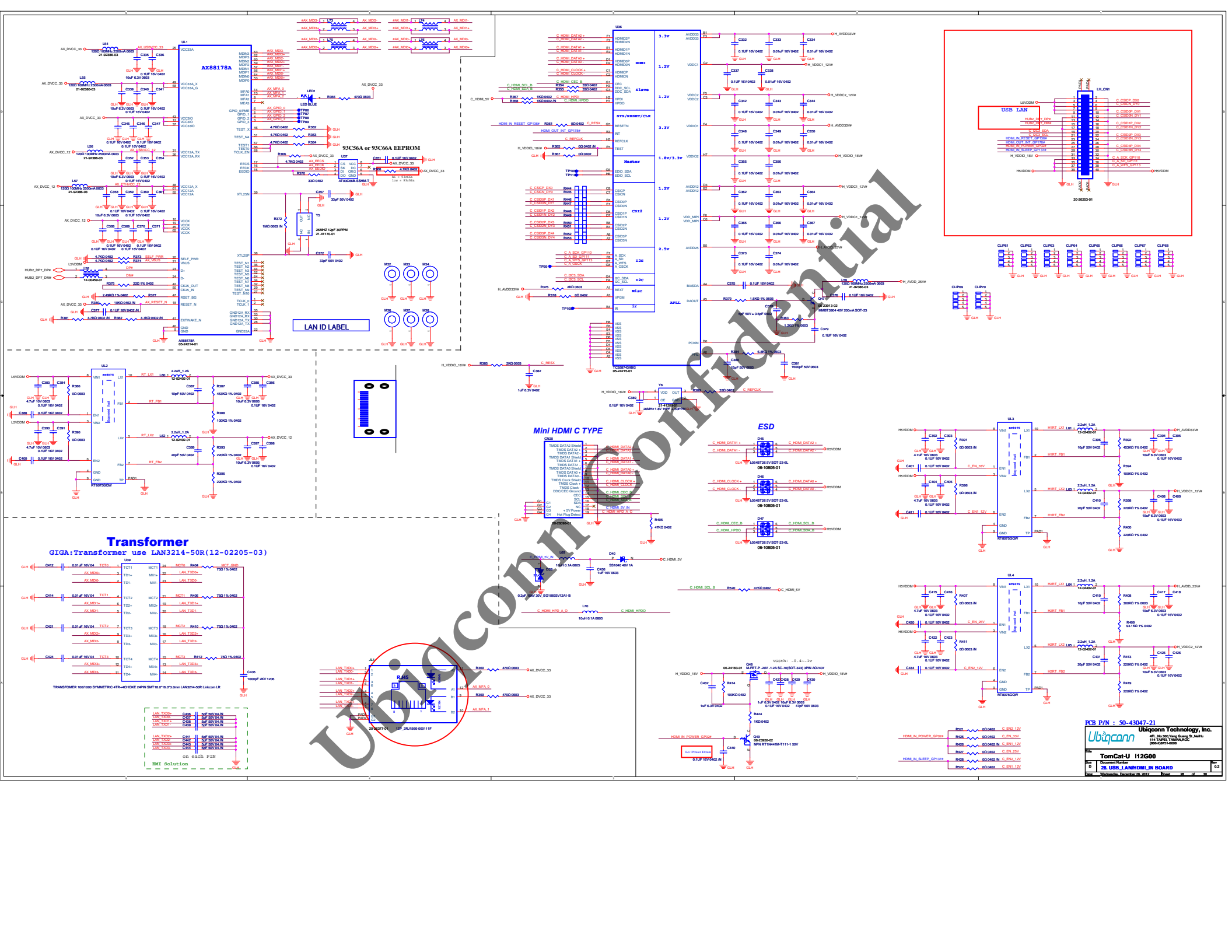

AX88178A

93C56A or 93C66A EEPROM

LAN ID LABEL

Mini HDMI C TYPE

ESD

USB LAN

Transformer

GIGA:Transformer use LAN3214-50R(12-02205-03)



PCB P/N : 50-43047-21

Ubiquinn Ubiquinn Technology, Inc.
 45, 78, 2075 Texas Gateway Dr., Austin, TX 78758, USA
 800-541-0288

TomCat-U H2G00
 Board Number: 0
 2x USB_LANH01 IN BOARD

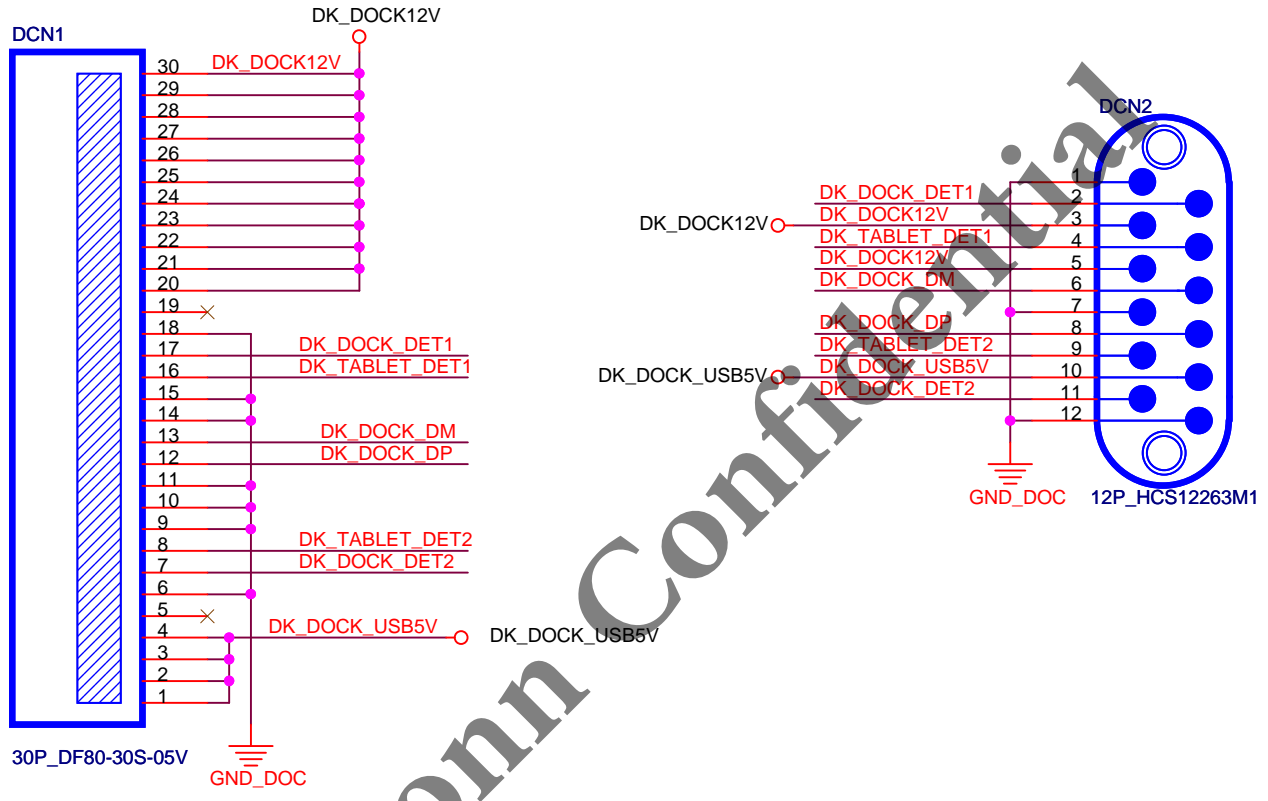

Ubiquconn Confidential

PCB P/N : 50-43048-21

Ubiquconn		Ubiquconn Technology, Inc.
		4FL.,No.300,Yang Guang St.,NeiHu 114 TAIPEI, TAIWAN,ROC (886-2)8751-6008
Title		
TomCat-U I12G00		
Size	Document Number	Rev
A	29. DOCKING Board	0.2
Date:	Wednesday, December 26, 2012	Sheet 29 of 30

Ubiqconn Confidential

		Ubiqconn Technology, Inc. 4FL, No.300, Yang Guang St., Nei-Hu 114 TAIPEI, TAIWAN, ROC (886-2)8751-6008
Title		
TomCat-U I12G00		
Size	Document Number	Rev
B	30. test	0.2
Date:	Wednesday, December 26, 2012	Sheet 30 of 30