



# FCC TEST REPORT

**REPORT NO.:** RF941229L01

**MODEL NO.:** QBTM400

**RECEIVED:** Dec. 29, 2005

**TESTED:** Jan. 02 ~ Jan. 03, 2006

**ISSUED:** Jan. 09, 2006

**APPLICANT:** Qcom Technology Inc.

**ADDRESS:** 7F, No. 178, Ming Chuan E. Rd., Sec 3, Taipei  
Taiwan, R.O.C.

**ISSUED BY:** Advance Data Technology Corporation

**LAB ADDRESS:** No. 47, 14<sup>th</sup> Ling, Chia Pau Tsuen, Lin Kou Hsiang  
244, Taipei Hsien, Taiwan, R.O.C.

**TEST LOCATION:** No. 19, Hwa Ya 2<sup>nd</sup> Rd., Wen Hwa Tsuen, Kwei  
Shan Hsiang, Taoyuan Hsien 333, Taiwan, R.O.C.

This test report consists of 88 pages in total. It may be duplicated completely for legal use with the approval of the applicant. It should not be reproduced except in full, without the written approval of our laboratory. The client should not use it to claim product endorsement by CNLA, A2LA or any government agencies. The test results in the report only apply to the tested sample.



NO. 2177-01



0528



## TABLE OF CONTENTS

1. CERTIFICATION.....	4
2. SUMMARY OF TEST RESULTS.....	5
2.1 MEASUREMENT UNCERTAINTY .....	6
3. GENERAL INFORMATION.....	7
3.1 GENERAL DESCRIPTION OF EUT .....	7
3.2 DESCRIPTION OF TEST MODES .....	8
3.2.1 CONFIGURATION OF SYSTEM UNDER TEST.....	9
3.2.2 TEST MODE APPLICABILITY AND TESTED CHANNEL DETAIL.....	10
3.3.3 GENERAL DESCRIPTION OF APPLIED STANDARDS.....	12
3.3.4 DESCRIPTION OF SUPPORT UNITS.....	12
4. TEST TYPES AND RESULTS.....	13
4.1 CONDUCTED EMISSION MEASUREMENT.....	13
4.1.1 LIMITS OF CONDUCTED EMISSION MEASUREMENT .....	13
4.1.2 TEST INSTRUMENTS .....	13
4.1.3 TEST PROCEDURES.....	14
4.1.4 DEVIATION FROM TEST STANDARD .....	14
4.1.5 TEST SETUP .....	15
4.1.6 EUT OPERATING CONDITIONS.....	16
4.1.7 TEST RESULTS.....	17
4.2 RADIATED EMISSION MEASUREMENT.....	29
4.2.1 LIMITS OF RADIATED EMISSION MEASUREMENT .....	29
4.2.2 TEST INSTRUMENTS .....	30
4.2.3 TEST PROCEDURES.....	31
4.2.4 DEVIATION FROM TEST STANDARD .....	31
4.2.5 TEST SETUP.....	32
4.2.6 EUT OPERATING CONDITIONS.....	32
4.2.7 TEST RESULTS.....	33
4.3 NUMBER OF HOPPING FREQUENCY USED.....	41
4.3.1 LIMIT OF HOPPING FREQUENCY USED .....	41
4.3.2 TEST INSTRUMENTS .....	41
4.3.3 TEST PROCEDURES.....	41
4.3.4 DEVIATION FROM TEST STANDARD .....	42
4.3.5 TEST SETUP .....	42
4.3.6 TEST RESULTS.....	42
4.4 DWELL TIME ON EACH CHANNEL.....	45
4.4.1 LIMIT OF DWELL TIME USED .....	45
4.4.2 TEST INSTRUMENTS .....	45
4.4.3 TEST PROCEDURES.....	45



4.4.4 DEVIATION FROM TEST STANDARD .....	45
4.4.5 TEST SETUP .....	46
4.4.6 TEST RESULTS .....	46
4.5 CHANNEL BANDWIDTH .....	54
4.5.1 LIMITS OF CHANNEL BANDWIDTH .....	54
4.5.2 TEST INSTRUMENTS .....	54
4.5.3 TEST PROCEDURE .....	54
4.5.4 DEVIATION FROM TEST STANDARD .....	55
4.5.5 TEST SETUP .....	55
4.5.6 EUT OPERATING CONDITION .....	55
4.5.7 TEST RESULTS .....	55
4.6 HOPPING CHANNEL SEPARATION .....	61
4.6.1 LIMIT OF HOPPING CHANNEL SEPARATION .....	61
4.6.2 TEST INSTRUMENTS .....	61
4.6.3 TEST PROCEDURES .....	61
4.6.4 DEVIATION FROM TEST STANDARD .....	62
4.6.5 TEST SETUP .....	62
4.6.6 TEST RESULTS .....	62
4.7 MAXIMUM PEAK OUTPUT POWER .....	68
4.7.1 LIMITS OF MAXIMUM PEAK OUTPUT POWER MEASUREMENT .....	68
4.7.2 TEST INSTRUMENTS .....	68
4.7.3 TEST PROCEDURES .....	68
4.7.4 DEVIATION FROM TEST STANDARD .....	68
4.7.5 TEST SETUP .....	69
4.7.6 EUT OPERATING CONDITION .....	69
4.7.7 TEST RESULTS .....	69
4.8 BAND EDGES MEASUREMENT .....	75
4.8.1 LIMITS OF BAND EDGES MEASUREMENT .....	75
4.8.2 TEST INSTRUMENTS .....	75
4.8.3 TEST PROCEDURE .....	75
4.8.4 DEVIATION FROM TEST STANDARD .....	75
4.8.5 EUT OPERATING CONDITION .....	75
4.8.6 TEST RESULTS .....	76
4.9 ANTENNA REQUIREMENT .....	82
4.9.1 STANDARD APPLICABLE .....	82
4.9.2 ANTENNA CONNECTED CONSTRUCTION .....	82
5. PHOTOGRAPHS OF THE TEST CONFIGURATION .....	83
6. INFORMATION ON THE TESTING LABORATORIES .....	87
APPENDIX-A .....	A-1



## 1. CERTIFICATION

**PRODUCT:** Bluetooth Module  
**MODEL NO.:** QBTM400  
**BRAND NAME:** Qcom Technology Inc.  
**APPLICANT:** Qcom Technology Inc.  
**TESTED:** Jan. 02 ~ Jan. 03, 2006  
**TEST SAMPLE:** ENGINEERING SAMPLE  
**STANDARDS:** FCC Part 15, Subpart C (Section 15.247),  
ANSI C63.4-2003

The above equipment (Model: QBTM400) have been tested by **Advance Data Technology Corporation**, and found compliance with the requirement of the above standards. The test record, data evaluation & Equipment Under Test (EUT) configurations represented herein are true and accurate accounts of the measurements of the sample's EMC characteristics under the conditions specified in this report.

**PREPARED BY :** Jessie Wang , **DATE:** Jan. 09, 2006  
Jessie Wang

**TECHNICAL ACCEPTANCE :** Long Chen , **DATE:** Jan. 09, 2006  
Responsible for RF Long Chen

**APPROVED BY :** Gary Chang , **DATE:** Jan. 09, 2006  
Gary Chang / Supervisor



## 2. SUMMARY OF TEST RESULTS

The EUT has been tested according to the following specifications:

APPLIED STANDARD: FCC Part 15, Subpart C			
STANDARD SECTION	TEST TYPE AND LIMIT	RESULT	REMARK
15.207	AC Power Conducted Emission	PASS	Meet the requirement of limit. Minimum passing margin is -16.17dB at 0.224MHz.
15.247(a)(1)(iii)	Number of Hopping Frequency Used Spec.: At least 15 channels	PASS	Meet the requirement of limit.
15.247(a)(1)(iii)	Dwell Time on Each Channel Spec. : Max. 0.4 second within 31.6 second	PASS	Meet the requirement of limit.
15.247(a)(1)	1. Hopping Channel Separation Spec. : Min. 25 kHz or 20 dB bandwidth, whichever is greater (see Note 1) 2. Spectrum Bandwidth of a Frequency Hopping Sequence Spread Spectrum System	PASS	Meet the requirement of limit.
15.247(b)	Maximum Peak Output Power Spec.: max. 30dBm (see Note 1)	PASS	Meet the requirement of limit.
15.247(d)	Transmitter Radiated Emissions Spec.: Table 15.209	PASS	Meet the requirement of limit. Minimum passing margin is -2.01 dB at 1602.00MHz.
15.247(d)	Band Edge Measurement	PASS	Meet the requirement of limit.

**NOTE:** If The Frequency Hopping System operating in 2400-2483.5MHz band and the output power less than 125mW. The hopping channel carrier frequencies separated by a minimum of 25kHz or two-thirds of the 20dB bandwidth of hopping channel whichever is greater.



## 2.1 MEASUREMENT UNCERTAINTY

Where relevant, the following measurement uncertainty levels have been estimated for tests performed on the EUT as specified in CISPR 16-4:

MEASUREMENT	FREQUENCY	UNCERTAINTY
Conducted emissions	9kHz ~ 30MHz	2.44 dB
Radiated emissions	30MHz ~ 200MHz	3.55 dB
	200MHz ~ 1000MHz	3.58 dB
	1GHz ~ 18GHz	1.10 dB
	18GHz ~ 40GHz	0.91 dB

This uncertainty represents an expanded uncertainty expressed at approximately the 95% confidence level using a coverage factor of  $k=2$ .



### 3. GENERAL INFORMATION

#### 3.1 GENERAL DESCRIPTION OF EUT

<b>PRODUCT</b>	Bluetooth Module
<b>MODEL NO.</b>	QBTM400
<b>POWER SUPPLY</b>	3.3Vdc from host equipment
<b>MODULATION TYPE</b>	GFSK, $\pi/4$ -DQPSK, 8DPSK
<b>RADIO TECHNOLOGY</b>	FHSS
<b>TRANSFER RATE</b>	1/2/3Mbps
<b>FREQUENCY RANGE</b>	2400 ~ 2483.5 MHz
<b>NUMBER OF CHANNEL</b>	79
<b>OUTPUT POWER</b>	1.714mW
<b>ANTENNA TYPE</b>	Print antenna with -4.67dBi gain
<b>DATA CABLE</b>	NA
<b>I/O PORTS</b>	NA
<b>ASSOCIATED DEVICES</b>	NA

**NOTE:**

The above EUT information was declared by manufacturer and for more detailed features description, please refer to the manufacturer's specifications or User's Manual.



### 3.2 DESCRIPTION OF TEST MODES

79 channels are provided to this EUT:

CHANNEL	FREQ. (MHz)	CHANNEL	FREQ. (MHz)	CHANNEL	FREQ. (MHz)	CHANNEL	FREQ. (MHz)
0	2402	20	2422	40	2442	60	2462
1	2403	21	2423	41	2443	61	2463
2	2404	22	2424	42	2444	62	2464
3	2405	23	2425	43	2445	63	2465
4	2406	24	2426	44	2446	64	2466
5	2407	25	2427	45	2447	65	2467
6	2408	26	2428	46	2448	66	2468
7	2409	27	2429	47	2449	67	2469
8	2410	28	2430	48	2450	68	2470
9	2411	29	2431	49	2451	69	2471
10	2412	30	2431	50	2452	70	2472
11	2413	31	2433	51	2453	71	2473
12	2414	32	2434	52	2454	72	2474
13	2415	33	2435	53	2455	73	2475
14	2416	34	2436	54	2456	74	2476
15	2417	35	2437	55	2457	75	2477
16	2418	36	2438	56	2458	76	2478
17	2419	37	2439	57	2459	77	2479
18	2420	38	2440	58	2460	78	2480
19	2421	39	2441	59	2461		





### 3.2.1 CONFIGURATION OF SYSTEM UNDER TEST

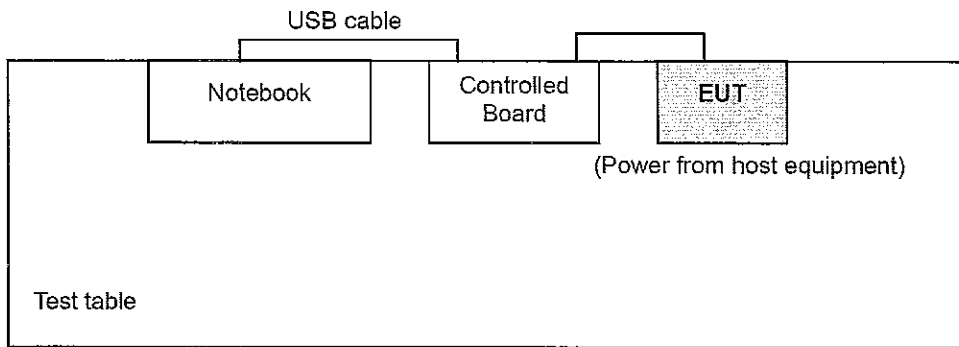



3.2.2 TEST MODE APPLICABILITY AND TESTED CHANNEL DETAIL

EUT CONFIGURE MODE	Applicable to				Description
	PLC	RE<1G	RE≥1G	APCM	
A	√	√	√	√	GFSK Modulation
B	√	√	√	√	8DPSK Modulation

Where PLC: Power Line Conducted Emission RE<1G: Radiated Emission below 1GHz  
 RE≥1G: Radiated Emission above 1GHz APCM: Antenna Port Conducted Measurement

**POWER LINE CONDUCTED EMISSION TEST:**

- Pre-Scan has been conducted to determine the worst-case mode from all possible combinations between available modulations and packet types.
- Following channel(s) was (were) selected for the final test as listed below.

EUT CONFIGURE MODE	AVAILABLE CHANNEL	TESTED CHANNEL	MODULATION TECHNOLOGY	MODULATION TYPE	PACKET TYPE
A	0 to 78	0, 39, 78	FHSS	GFSK	DH5
B	0 to 78	0, 39, 78	FHSS	8DPSK	DH5

**RADIATED EMISSION TEST (BELOW 1 GHz):**

- Pre-Scan has been conducted to determine the worst-case mode from all possible combinations between available modulations, packet types and XYZ axis.
- Following channel(s) was (were) selected for the final test as listed below.

EUT CONFIGURE MODE	AVAILABLE CHANNEL	TESTED CHANNEL	MODULATION TECHNOLOGY	MODULATION TYPE	PACKET TYPE	AXIS
A	0 to 78	78	FHSS	GFSK	DH5	Z
B	0 to 78	78	FHSS	8DPSK	DH5	Z

**RADIATED EMISSION TEST (ABOVE 1 GHz):**

- Pre-Scan has been conducted to determine the worst-case mode from all possible combinations between available modulations, packet types and XYZ axis.
- Following channel(s) was (were) selected for the final test as listed below.

EUT CONFIGURE MODE	AVAILABLE CHANNEL	TESTED CHANNEL	MODULATION TECHNOLOGY	MODULATION TYPE	PACKET TYPE	AXIS
A	0 to 78	0, 39, 78	FHSS	GFSK	DH5	Z
B	0 to 78	0, 39, 78	FHSS	8DPSK	DH5	Z

**BANDEDGE MEASUREMENT:**

- Pre-Scan has been conducted to determine the worst-case mode from all possible combinations between available modulations and packet types.
- Following channel(s) was (were) selected for the final test as listed below.

EUT CONFIGURE MODE	AVAILABLE CHANNEL	TESTED CHANNEL	MODULATION TECHNOLOGY	MODULATION TYPE	PACKET TYPE
A	0 to 78	0, 78	FHSS	GFSK	DH5
B	0 to 78	0, 78	FHSS	8DPSK	DH5

**ANTENNA PORT CONDUCTED MEASUREMENT:**

- Pre-Scan has been conducted to determine the worst-case mode from all possible combinations between available modulations and packet types.
- Following channel(s) was (were) selected for the final test as listed below.

EUT CONFIGURE MODE	AVAILABLE CHANNEL	TESTED CHANNEL	MODULATION TECHNOLOGY	MODULATION TYPE	PACKET TYPE
A	0 to 78	0, 39, 78	FHSS	GFSK	DH5
B	0 to 78	0, 39, 78	FHSS	8DPSK	DH5



### 3.3.3 GENERAL DESCRIPTION OF APPLIED STANDARDS

The EUT is a Bluetooth Module. According to the specifications of the manufacturer, it must comply with the requirements of the following standards:

**FCC Part 15, Subpart C. (15.247)**

**ANSI C63.4- 2003**

All test items have been performed and recorded as per the above standards.

**NOTE:** The EUT is also considered as a kind of computer peripheral, because the connection to computer is necessary for typical use. It has been verified to comply with the requirements of FCC Part 15, Subpart B, Class B (DoC). The test report has been issued separately.

### 3.3.4 DESCRIPTION OF SUPPORT UNITS

The EUT has been tested as an independent unit together with other necessary accessories or support units. The following support units or accessories were used to form a representative test configuration during the tests.

NO.	PRODUCT	BRAND	MODEL NO.	SERIAL NO.	FCC ID
1	NOTEBOOK	Compaq	N800C	470048-515	FCC DoC Approved
2	Controlled Board	NA	NA	NA	NA

NO.	SIGNAL CABLE DESCRIPTION OF THE ABOVE SUPPORT UNITS
1	NA
2	1.5 m shielded USB cable without core

**NOTE:** All power cords of the above support units are non shielded (1.8m).



## 4. TEST TYPES AND RESULTS

### 4.1 CONDUCTED EMISSION MEASUREMENT

#### 4.1.1 LIMITS OF CONDUCTED EMISSION MEASUREMENT

FREQUENCY OF EMISSION (MHz)	CONDUCTED LIMIT (dB $\mu$ V)	
	Quasi-peak	Average
0.15 ~ 0.5	66 to 56	56 to 46
0.5 ~ 5	56	46
5 ~ 30	60	50

- NOTE:**
1. The lower limit shall apply at the transition frequencies.
  2. The limit decreases in line with the logarithm of the frequency in the range of 0.15 to 0.50 MHz.
  3. All emanations from a class A/B digital device or system, including any network of conductors and apparatus connected thereto, shall not exceed the level of field strengths specified above.

#### 4.1.2 TEST INSTRUMENTS

DESCRIPTION & MANUFACTURER	MODEL NO.	SERIAL NO.	CALIBRATED UNTIL
Test Receiver ROHDE & SCHWARZ	ESCS30	100288	Nov. 02, 2006
RF signal cable Woken	5D-FB	Cable-HyC02-01	Jan. 09, 2006
V-LISN SCHWARZBECK	NNBL 8226-2	8226-142	May 02, 2006
LISN ROHDE & SCHWARZ	ESH3-Z5	100311	Jan. 20, 2006
Software ADT	ADT_Cond_V3	NA	NA

- NOTE:**
1. The calibration interval of the above test instruments is 12 months and the calibrations are traceable to NML/ROC and NIST/USA.
  2. The test was performed in HwaYa Shielded Room 3.
  3. The VCCI Site Registration No. is C-2047.



#### 4.1.3 TEST PROCEDURES

- a. The EUT was placed 0.4 meters from the conducting wall of the shielded room with EUT being connected to the power mains through a line impedance stabilization network (LISN). Other support units were connected to the power mains through another LISN. The two LISNs provide 50 ohm/ 50uH of coupling impedance for the measuring instrument.
- b. Both lines of the power mains connected to the EUT were checked for maximum conducted interference.
- c. The frequency range from 150kHz to 30MHz was searched. Emission levels under (Limit - 20dB) was not recorded.

#### 4.1.4 DEVIATION FROM TEST STANDARD

No deviation

## 4.1.5 TEST SETUP

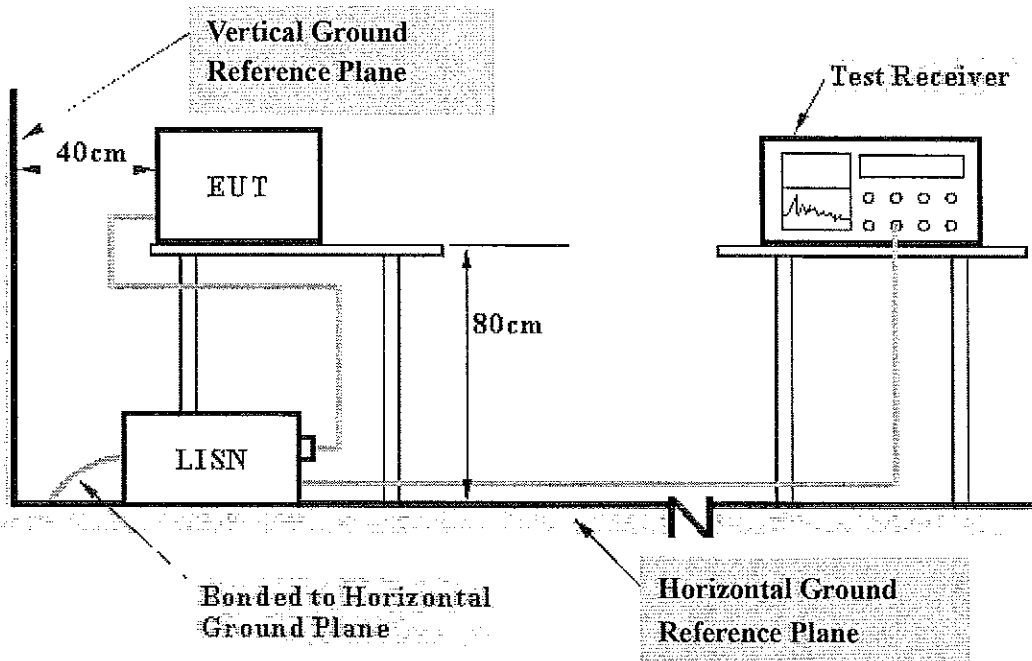

- Note: 1. Support units were connected to second LISN.  
 2. Both of LISNs (AMN) 80 cm from EUT and at the least 80 cm from other units and other metal planes support units.

For the actual test configuration, please refer to the related item – Photographs of the Test Configuration.



#### 4.1.6 EUT OPERATING CONDITIONS

- a. Connected the EUT to the Notebook system via controlled board.
- b. The Notebook system ran a test program (provided by manufacturer) to enable EUT under transmission condition continuously at specific channel frequency.
- c. The notebook system sent "H" messages to its screen.
- d. Steps c were repeated.





4.1.7 TEST RESULTS

CONDUCTED WORST CASE DATA: MODE A FOR GFSK

EUT TEST CONDITION		MEASUREMENT DETAIL	
CHANNEL	Channel 0	PHASE	Line 1
MODULATION TYPE	GFSK	6dB BANDWIDTH	9 kHz
TEST MODE	A	ENVIRONMENTAL CONDITIONS	25deg. C, 65%RH, 991hPa
TESTED BY	Jay Hsu	INPUT POWER (SYSTEM)	120Vac, 60 Hz

No	Freq. [MHz]	Corr. Factor (dB)	Reading Value [dB (uV)]		Emission Level [dB (uV)]		Limit [dB (uV)]		Margin (dB)	
			Q.P.	AV.	Q.P.	AV.	Q.P.	AV.	Q.P.	AV.
			1	0.228	0.11	45.64	-	45.75	-	62.52
2	0.349	0.12	34.50	-	34.62	-	58.98	48.98	-24.36	-
3	0.447	0.13	34.99	-	35.12	-	56.93	46.93	-21.81	-
4	1.156	0.23	23.46	-	23.69	-	56.00	46.00	-32.31	-
5	4.422	0.30	27.99	-	28.29	-	56.00	46.00	-27.71	-
6	10.684	0.46	27.11	-	27.57	-	60.00	50.00	-32.43	-

- REMARKS: 1. Q.P. and AV. are abbreviations of quasi-peak and average individually.  
 2. "-": The Quasi-peak reading value also meets average limit and measurement with the average detector is unnecessary.  
 3. The emission levels of other frequencies were very low against the limit.  
 4. Margin value = Emission level - Limit value  
 5. Correction factor = Insertion loss + Cable loss  
 6. Emission Level = Correction Factor + Reading Value.

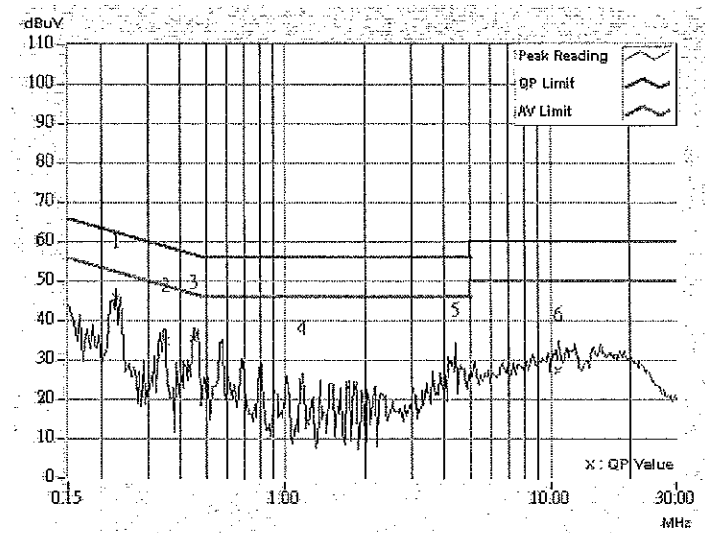



EUT TEST CONDITION		MEASUREMENT DETAIL	
CHANNEL	Channel 0	PHASE	Line 2
MODULATION TYPE	GFSK	6dB BANDWIDTH	9 kHz
TEST MODE	A	ENVIRONMENTAL CONDITIONS	25deg. C, 65%RH, 991hPa
TESTED BY	Jay Hsu	INPUT POWER (SYSTEM)	120Vac, 60 Hz

No	Freq. [MHz]	Corr. Factor (dB)	Reading Value [dB (uV)]		Emission Level [dB (uV)]		Limit [dB (uV)]		Margin (dB)	
			Q.P.	AV.	Q.P.	AV.	Q.P.	AV.	Q.P.	AV.
			1	0.224	0.11	44.58	-	44.69	-	62.66
2	0.345	0.12	35.97	-	36.09	-	59.07	49.07	-22.99	-
3	0.451	0.13	34.07	-	34.20	-	56.86	46.86	-22.66	-
4	0.576	0.15	31.70	-	31.85	-	56.00	46.00	-24.15	-
5	4.199	0.30	28.89	-	29.19	-	56.00	46.00	-26.81	-
6	15.820	0.70	28.52	-	29.22	-	60.00	50.00	-30.78	-

- REMARKS:**
1. Q.P. and AV. are abbreviations of quasi-peak and average individually.
  2. "-": The Quasi-peak reading value also meets average limit and measurement with the average detector is unnecessary.
  3. The emission levels of other frequencies were very low against the limit.
  4. Margin value = Emission level - Limit value
  5. Correction factor = Insertion loss + Cable loss
  6. Emission Level = Correction Factor + Reading Value.

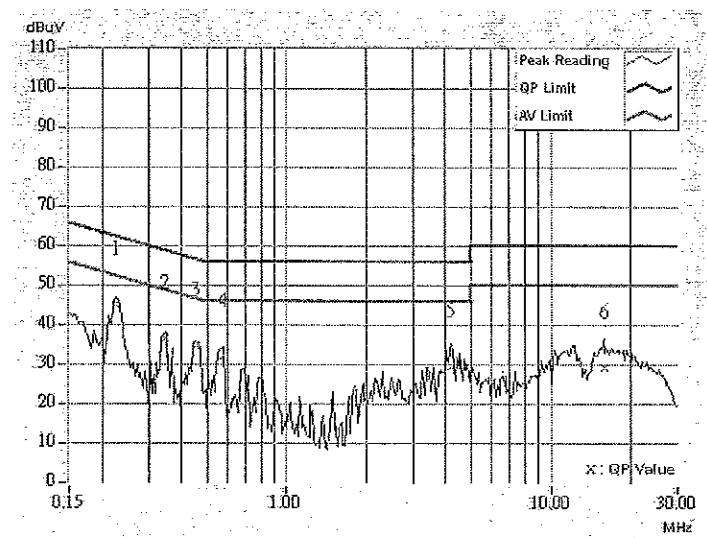



EUT TEST CONDITION		MEASUREMENT DETAIL	
CHANNEL	Channel 39	PHASE	Line 1
MODULATION TYPE	GFSK	6dB BANDWIDTH	9 kHz
TEST MODE	A	ENVIRONMENTAL CONDITIONS	25deg. C, 65%RH, 991hPa
TESTED BY	Jay Hsu	INPUT POWER (SYSTEM)	120Vac, 60 Hz

No	Freq. [MHz]	Corr. Factor (dB)	Reading Value [dB (uV)]		Emission Level [dB (uV)]		Limit [dB (uV)]		Margin (dB)	
			Q.P.	AV.	Q.P.	AV.	Q.P.	AV.	Q.P.	AV.
1	0.224	0.11	45.90	-	46.01	-	62.66	52.66	-16.65	-
2	0.353	0.12	29.53	-	29.65	-	58.89	48.89	-29.24	-
3	0.447	0.13	34.43	-	34.56	-	56.93	46.93	-22.37	-
4	0.810	0.20	26.05	-	26.25	-	56.00	46.00	-29.75	-
5	4.316	0.30	28.71	-	29.01	-	56.00	46.00	-26.99	-
6	15.078	0.56	27.95	-	28.51	-	60.00	50.00	-31.49	-

- REMARKS:**
1. Q.P. and AV. are abbreviations of quasi-peak and average individually.
  2. "-": The Quasi-peak reading value also meets average limit and measurement with the average detector is unnecessary.
  3. The emission levels of other frequencies were very low against the limit.
  4. Margin value = Emission level - Limit value
  5. Correction factor = Insertion loss + Cable loss
  6. Emission Level = Correction Factor + Reading Value.

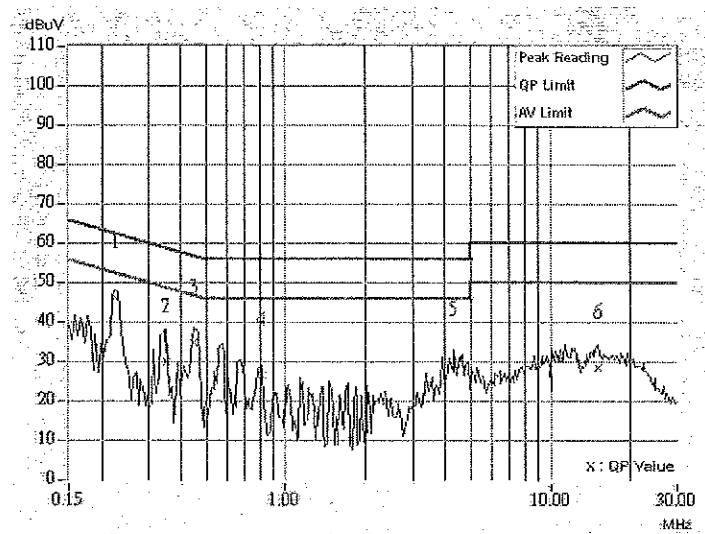



EUT TEST CONDITION		MEASUREMENT DETAIL	
CHANNEL	Channel 39	PHASE	Line 2
MODULATION TYPE	GFSK	6dB BANDWIDTH	9 kHz
TEST MODE	A	ENVIRONMENTAL CONDITIONS	25deg. C, 65%RH, 991hPa
TESTED BY	Jay Hsu	INPUT POWER (SYSTEM)	120Vac, 60 Hz

No	Freq. [MHz]	Corr. Factor [dB]	Reading Value [dB (uV)]		Emission Level [dB (uV)]		Limit [dB (uV)]		Margin [dB]	
			Q.P.	AV.	Q.P.	AV.	Q.P.	AV.	Q.P.	AV.
			1	0.220	0.11	39.02	-	39.13	-	62.81
2	0.345	0.12	35.81	-	35.93	-	59.07	49.07	-23.15	-
3	0.451	0.13	34.05	-	34.18	-	56.86	46.86	-22.68	-
4	2.141	0.25	24.16	-	24.41	-	56.00	46.00	-31.59	-
5	4.352	0.30	25.65	-	25.95	-	56.00	46.00	-30.05	-
6	16.707	0.76	28.03	-	28.79	-	60.00	50.00	-31.21	-

- REMARKS:**
1. Q.P. and AV. are abbreviations of quasi-peak and average individually.
  2. "-": The Quasi-peak reading value also meets average limit and measurement with the average detector is unnecessary.
  3. The emission levels of other frequencies were very low against the limit.
  4. Margin value = Emission level - Limit value
  5. Correction factor = Insertion loss + Cable loss
  6. Emission Level = Correction Factor + Reading Value.

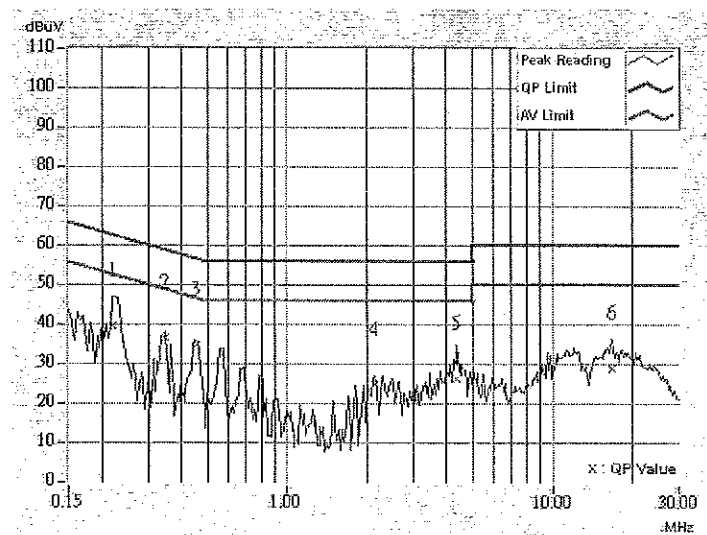



EUT TEST CONDITION		MEASUREMENT DETAIL	
CHANNEL	Channel 78	PHASE	Line 1
MODULATION TYPE	GFSK	6dB BANDWIDTH	9 kHz
TEST MODE	A	ENVIRONMENTAL CONDITIONS	25deg. C, 65%RH, 991hPa
TESTED BY	Jay Hsu	INPUT POWER (SYSTEM)	120Vac, 60 Hz

No	Freq. [MHz]	Corr. Factor (dB)	Reading Value [dB (uV)]		Emission Level [dB (uV)]		Limit [dB (uV)]		Margin (dB)	
			Q.P.	AV.	Q.P.	AV.	Q.P.	AV.	Q.P.	AV.
			1	0.228	0.11	44.70	-	44.81	-	62.52
2	0.345	0.12	35.48	-	35.60	-	59.07	49.07	-23.48	-
3	0.584	0.15	32.01	-	32.16	-	56.00	46.00	-23.84	-
4	2.188	0.25	23.70	-	23.95	-	56.00	46.00	-32.05	-
5	4.168	0.29	22.07	-	22.36	-	56.00	46.00	-33.64	-
6	15.578	0.60	28.96	-	29.56	-	60.00	50.00	-30.44	-

- REMARKS:**
1. Q.P. and AV. are abbreviations of quasi-peak and average individually.
  2. "-": The Quasi-peak reading value also meets average limit and measurement with the average detector is unnecessary.
  3. The emission levels of other frequencies were very low against the limit.
  4. Margin value = Emission level - Limit value
  5. Correction factor = Insertion loss + Cable loss
  6. Emission Level = Correction Factor + Reading Value.

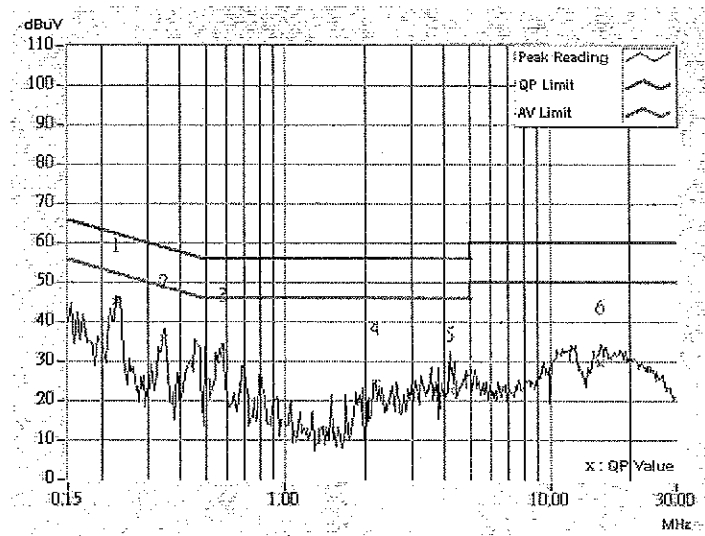



EUT TEST CONDITION		MEASUREMENT DETAIL	
CHANNEL	Channel 78	PHASE	Line 2
MODULATION TYPE	GFSK	6dB BANDWIDTH	9 kHz
TEST MODE	A	ENVIRONMENTAL CONDITIONS	25deg. C, 65%RH, 991hPa
TESTED BY	Jay Hsu	INPUT POWER (SYSTEM)	120Vac, 60 Hz

No	Freq. [MHz]	Corr. Factor (dB)	Reading Value [dB (uV)]		Emission Level [dB (uV)]		Limit [dB (uV)]		Margin (dB)	
			Q.P.	AV.	Q.P.	AV.	Q.P.	AV.	Q.P.	AV.
			1	0.228	0.11	45.92	-	46.03	-	62.52
2	0.345	0.12	35.42	-	35.54	-	59.07	49.07	-23.54	-
3	0.459	0.13	35.42	-	35.55	-	56.72	46.72	-21.17	-
4	0.584	0.15	32.55	-	32.70	-	56.00	46.00	-23.30	-
5	4.207	0.30	28.80	-	29.10	-	56.00	46.00	-26.90	-
6	14.395	0.64	27.61	-	28.25	-	60.00	50.00	-31.75	-

- REMARKS:**
1. Q.P. and AV. are abbreviations of quasi-peak and average individually.
  2. "-": The Quasi-peak reading value also meets average limit and measurement with the average detector is unnecessary.
  3. The emission levels of other frequencies were very low against the limit.
  4. Margin value = Emission level - Limit value
  5. Correction factor = Insertion loss + Cable loss
  6. Emission Level = Correction Factor + Reading Value.

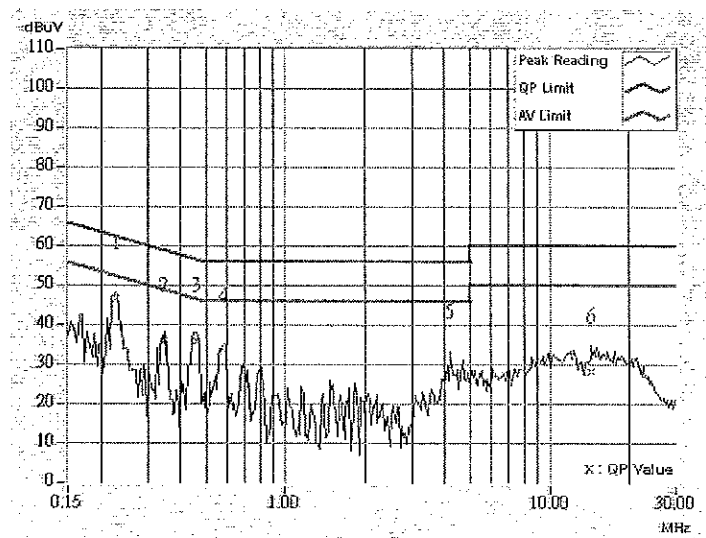



CONDUCTED WORST CASE DATA: MODE B FOR 8DPSK

EUT TEST CONDITION		MEASUREMENT DETAIL	
CHANNEL	Channel 0	PHASE	Line 1
MODULATION TYPE	8DPSK	6dB BANDWIDTH	9 kHz
TEST MODE	B	ENVIRONMENTAL CONDITIONS	25deg. C, 65%RH, 991hPa
TESTED BY	Jay Hsu	INPUT POWER (SYSTEM)	120Vac, 60 Hz

No	Freq. [MHz]	Corr. Factor (dB)	Reading Value		Emission Level		Limit		Margin	
			[dB (uV)]		[dB (uV)]		[dB (uV)]		(dB)	
			Q.P.	AV.	Q.P.	AV.	Q.P.	AV.	Q.P.	AV.
1	0.228	0.11	44.50	-	44.61	-	62.52	52.52	-17.91	-
2	0.349	0.12	35.95	-	36.07	-	58.98	48.98	-22.91	-
3	0.459	0.13	33.59	-	33.72	-	56.72	46.72	-23.00	-
4	0.584	0.15	30.49	-	30.64	-	56.00	46.00	-25.36	-
5	3.855	0.29	19.86	-	20.15	-	56.00	46.00	-35.85	-
6	16.398	0.67	28.82	-	29.49	-	60.00	50.00	-30.51	-

- REMARKS:
1. Q.P. and AV. are abbreviations of quasi-peak and average individually.
  2. "-": The Quasi-peak reading value also meets average limit and measurement with the average detector is unnecessary.
  3. The emission levels of other frequencies were very low against the limit.
  4. Margin value = Emission level - Limit value
  5. Correction factor = Insertion loss + Cable loss
  6. Emission Level = Correction Factor + Reading Value.

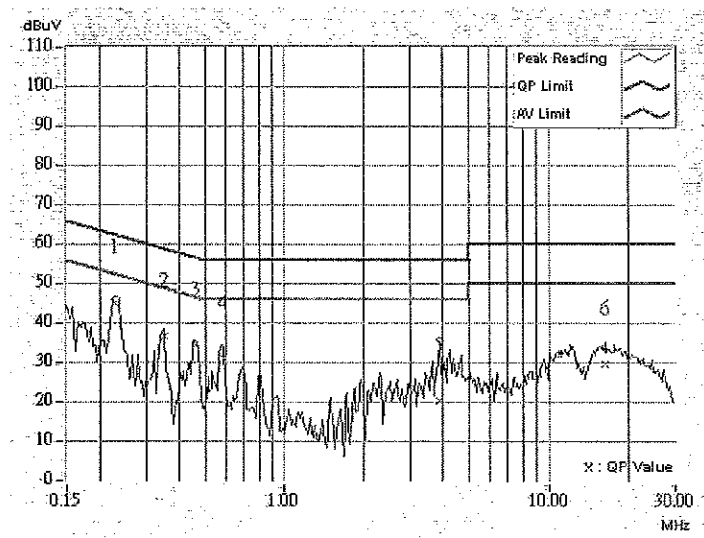



EUT TEST CONDITION		MEASUREMENT DETAIL	
CHANNEL	Channel 0	PHASE	Line 2
MODULATION TYPE	8DPSK	6dB BANDWIDTH	9 kHz
TEST MODE	B	ENVIRONMENTAL CONDITIONS	25deg. C, 65%RH, 991hPa
TESTED BY	Jay Hsu	INPUT POWER (SYSTEM)	120Vac, 60 Hz

No	Freq. [MHz]	Corr. Factor (dB)	Reading Value [dB (uV)]		Emission Level [dB (uV)]		Limit [dB (uV)]		Margin (dB)	
			Q.P.	AV.	Q.P.	AV.	Q.P.	AV.	Q.P.	AV.
			1	0.224	0.11	46.38	-	46.49	-	62.66
2	0.349	0.12	35.32	-	35.44	-	58.98	48.98	-23.54	-
3	0.451	0.13	35.50	-	35.63	-	56.86	46.86	-21.23	-
4	0.814	0.20	26.05	-	26.25	-	56.00	46.00	-29.75	-
5	4.125	0.30	24.55	-	24.85	-	56.00	46.00	-31.15	-
6	14.297	0.63	27.47	-	28.10	-	60.00	50.00	-31.90	-

- REMARKS:
1. Q.P. and AV. are abbreviations of quasi-peak and average individually.
  2. "-": The Quasi-peak reading value also meets average limit and measurement with the average detector is unnecessary.
  3. The emission levels of other frequencies were very low against the limit.
  4. Margin value = Emission level - Limit value
  5. Correction factor = Insertion loss + Cable loss
  6. Emission Level = Correction Factor + Reading Value.

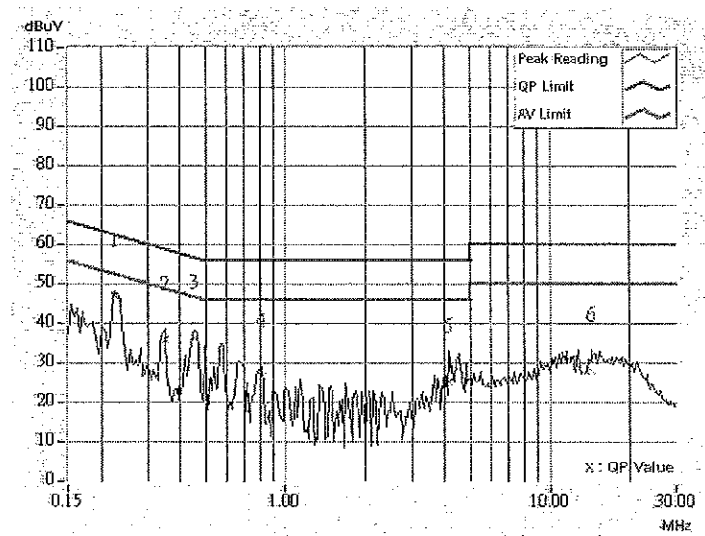





EUT TEST CONDITION		MEASUREMENT DETAIL	
CHANNEL	Channel 39	PHASE	Line 1
MODULATION TYPE	8DPSK	6dB BANDWIDTH	9 kHz
TEST MODE	B	ENVIRONMENTAL CONDITIONS	25deg. C, 65%RH, 991hPa
TESTED BY	Jay Hsu	INPUT POWER (SYSTEM)	120Vac, 60 Hz

No	Freq. [MHz]	Corr. Factor (dB)	Reading Value [dB (uV)]		Emission Level [dB (uV)]		Limit [dB (uV)]		Margin (dB)	
			Q.P.	AV.	Q.P.	AV.	Q.P.	AV.	Q.P.	AV.
			1	0.224	0.11	44.44	-	44.55	-	62.66
2	0.349	0.12	35.62	-	35.74	-	58.98	48.98	-23.24	-
3	0.451	0.13	33.73	-	33.86	-	56.86	46.86	-23.00	-
4	2.305	0.26	25.10	-	25.36	-	56.00	46.00	-30.64	-
5	4.180	0.29	28.51	-	28.80	-	56.00	46.00	-27.20	-
6	15.949	0.63	28.62	-	29.25	-	60.00	50.00	-30.75	-

- REMARKS:**
1. Q.P. and AV. are abbreviations of quasi-peak and average individually.
  2. "-": The Quasi-peak reading value also meets average limit and measurement with the average detector is unnecessary.
  3. The emission levels of other frequencies were very low against the limit.
  4. Margin value = Emission level - Limit value
  5. Correction factor = Insertion loss + Cable loss
  6. Emission Level = Correction Factor + Reading Value.

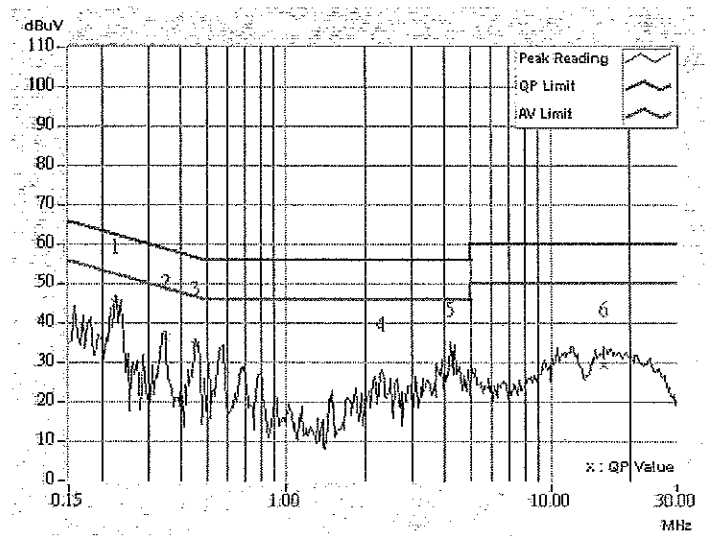



EUT TEST CONDITION		MEASUREMENT DETAIL	
CHANNEL	Channel 39	PHASE	Line 2
MODULATION TYPE	8DPSK	6dB BANDWIDTH	9 kHz
TEST MODE	B	ENVIRONMENTAL CONDITIONS	25deg. C, 65%RH, 991hPa
TESTED BY	Jay Hsu	INPUT POWER (SYSTEM)	120Vac, 60 Hz

No	Freq. [MHz]	Corr. Factor (dB)	Reading Value [dB (uV)]		Emission Level [dB (uV)]		Limit [dB (uV)]		Margin (dB)	
			Q.P.	AV.	Q.P.	AV.	Q.P.	AV.	Q.P.	AV.
			1	0.228	0.11	45.82	-	45.93	-	62.52
2	0.459	0.13	35.32	-	35.45	-	56.72	46.72	-21.27	-
3	0.584	0.15	30.92	-	31.07	-	56.00	46.00	-24.93	-
4	0.810	0.20	25.42	-	25.62	-	56.00	46.00	-30.38	-
5	3.855	0.29	22.81	-	23.10	-	56.00	46.00	-32.90	-
6	14.340	0.64	27.55	-	28.19	-	60.00	50.00	-31.81	-

- REMARKS:**
1. Q.P. and AV. are abbreviations of quasi-peak and average individually.
  2. "-": The Quasi-peak reading value also meets average limit and measurement with the average detector is unnecessary.
  3. The emission levels of other frequencies were very low against the limit.
  4. Margin value = Emission level - Limit value
  5. Correction factor = Insertion loss + Cable loss
  6. Emission Level = Correction Factor + Reading Value.

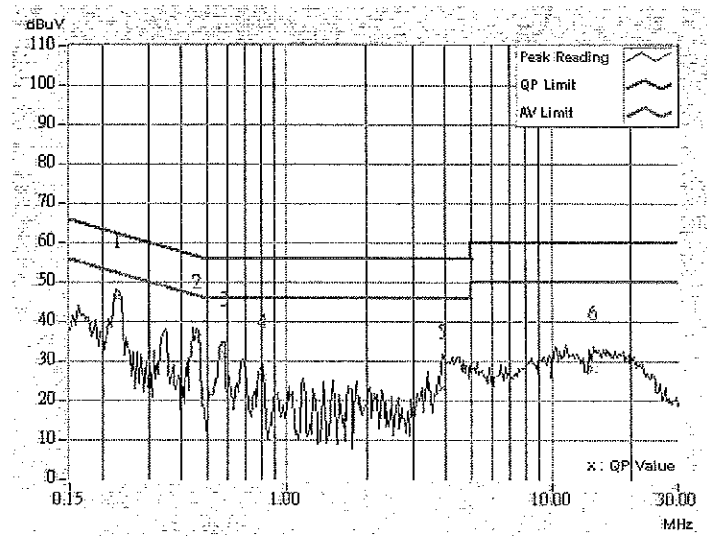



EUT TEST CONDITION		MEASUREMENT DETAIL	
CHANNEL	Channel 78	PHASE	Line 1
MODULATION TYPE	8DPSK	6dB BANDWIDTH	9 kHz
TEST MODE	B	ENVIRONMENTAL CONDITIONS	25deg. C, 65%RH, 991hPa
TESTED BY	Jay Hsu	INPUT POWER (SYSTEM)	120Vac, 60 Hz

No	Freq. [MHz]	Corr. Factor (dB)	Reading Value [dB (uV)]		Emission Level [dB (uV)]		Limit [dB (uV)]		Margin (dB)	
			Q.P.	AV.	Q.P.	AV.	Q.P.	AV.	Q.P.	AV.
			1	0.224	0.11	42.10	-	42.21	-	62.66
2	0.349	0.12	36.19	-	36.31	-	58.98	48.98	-22.67	-
3	0.584	0.15	32.01	-	32.16	-	56.00	46.00	-23.84	-
4	2.316	0.26	25.36	-	25.62	-	56.00	46.00	-30.38	-
5	4.238	0.30	28.88	-	29.18	-	56.00	46.00	-26.82	-
6	12.379	0.49	28.19	-	28.68	-	60.00	50.00	-31.32	-

- REMARKS:
1. Q.P. and AV. are abbreviations of quasi-peak and average individually.
  2. "-": The Quasi-peak reading value also meets average limit and measurement with the average detector is unnecessary.
  3. The emission levels of other frequencies were very low against the limit.
  4. Margin value = Emission level - Limit value
  5. Correction factor = Insertion loss + Cable loss
  6. Emission Level = Correction Factor + Reading Value.

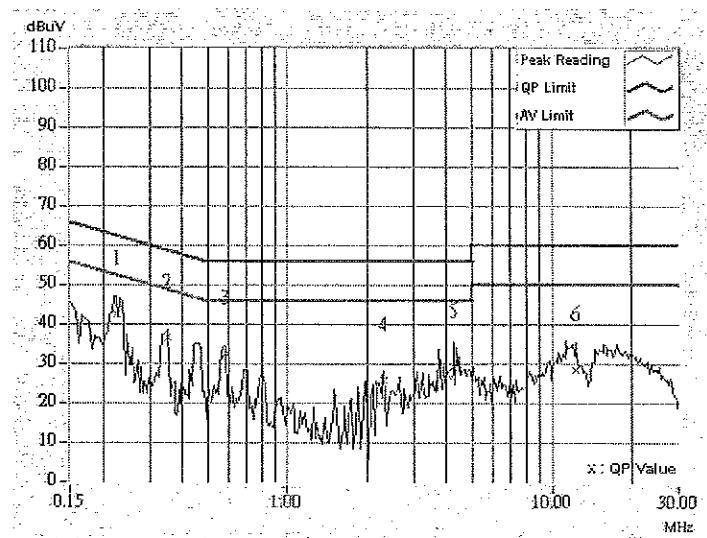



EUT TEST CONDITION		MEASUREMENT DETAIL	
CHANNEL	Channel 78	PHASE	Line 2
MODULATION TYPE	8DPSK	6dB BANDWIDTH	9 kHz
TEST MODE	B	ENVIRONMENTAL CONDITIONS	25deg. C, 65%RH, 991hPa
TESTED BY	Jay Hsu	INPUT POWER (SYSTEM)	120Vac, 60 Hz

No	Freq. [MHz]	Corr. Factor [dB]	Reading Value [dB (uV)]		Emission Level [dB (uV)]		Limit [dB (uV)]		Margin (dB)	
			Q.P.	AV.	Q.P.	AV.	Q.P.	AV.	Q.P.	AV.
1	0.232	0.11	45.79	-	45.90	-	62.38	52.38	-16.48	-
2	0.349	0.12	36.13	-	36.25	-	58.98	48.98	-22.73	-
3	0.451	0.13	36.13	-	36.26	-	56.86	46.86	-20.60	-
4	0.584	0.15	31.27	-	31.42	-	56.00	46.00	-24.58	-
5	4.223	0.30	28.77	-	29.07	-	56.00	46.00	-26.93	-
6	15.875	0.71	27.59	-	28.30	-	60.00	50.00	-31.70	-

- REMARKS:**
1. Q.P. and AV. are abbreviations of quasi-peak and average individually.
  2. "-": The Quasi-peak reading value also meets average limit and measurement with the average detector is unnecessary.
  3. The emission levels of other frequencies were very low against the limit.
  4. Margin value = Emission level - Limit value
  5. Correction factor = Insertion loss + Cable loss
  6. Emission Level = Correction Factor + Reading Value.

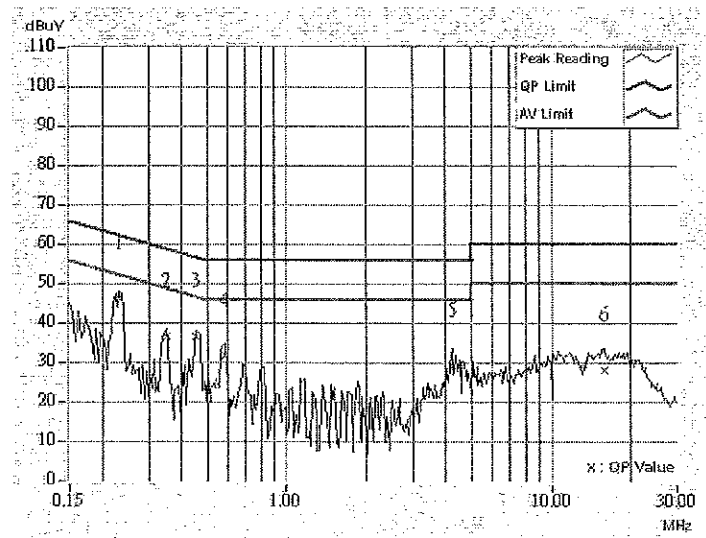



## 4.2 RADIATED EMISSION MEASUREMENT

### 4.2.1 LIMITS OF RADIATED EMISSION MEASUREMENT

Emissions radiated outside of the specified bands, shall be according to the general radiated limits in 15.209 as following:

FREQUENCIES (MHz)	FIELD STRENGTH (microvolts/meter)	MEASUREMENT DISTANCE (meters)
0.009 ~ 0.490	2400/F(kHz)	300
0.490 ~ 1.705	24000/F(kHz)	30
1.705 ~ 30.0	30	30
30 ~ 88	100	3
88 ~ 216	150	3
216 ~ 960	200	3
Above 960	500	3

**NOTE:**

1. The lower limit shall apply at the transition frequencies.
2. Emission level (dBuV/m) = 20 log Emission level (uV/m).
3. As shown in 15.35(b), for frequencies above 1000MHz, the field strength limits are based on average detector, however, the peak field strength of any emission shall not exceed the maximum permitted average limits, specified above by more than 20dB under any condition of modulation.



## 4.2.2 TEST INSTRUMENTS

DESCRIPTION & MANUFACTURER	MODEL NO.	SERIAL NO.	CALIBRATED UNTIL
Test Receiver ROHDE & SCHWARZ	ESI7	100033	May. 19, 2006
Spectrum Analyzer ROHDE & SCHWARZ	FSP40	100025	Dec. 05, 2006
BILOG Antenna SCHWARZBECK	VULB9168	9168-160	Jun. 01, 2006
HORN Antenna SCHWARZBECK	9120D	9120D-408	Jan. 17, 2006
HORN Antenna SCHWARZBECK	BBHA 9170	BBHA9170243	Jan. 23, 2006
Preamplifier Agilent	8447D	2944A10633	Nov. 04, 2006
Preamplifier Agilent	8449B	3008A01964	Oct. 30, 2006
RF signal cable HUBER+SUHNNER	SUCOFLEX 104	218183/4	Jan. 26, 2006
RF signal cable HUBER+SUHNNER	SUCOFLEX 104	218195/4	Jan. 26, 2006
Software ADT.	ADT_Radiated_V5.14	NA	NA
Antenna Tower inn-co GmbH	MA 4000	013303	NA
Antenna Tower Controller inn-co GmbH	CO2000	017303	NA
Turn Table ADT.	TT100.	TT93021703	NA
Turn Table Controller ADT.	SC100.	SC93021703	NA

**NOTE:** 1. The calibration interval of the above test instruments is 12 months and the calibrations are traceable to NML/ROC and NIST/USA.

2. The test was performed in HwaYa Chamber 2.

3. The horn antenna and HP preamplifier (model: 8449B) are used only for the measurement of emission frequency above 1GHz if tested.

4. The VCCI Site Registration No. is R-237.

5. The IC Site Registration No. is IC4924-3.



#### 4.2.3 TEST PROCEDURES

- a. The EUT was placed on the top of a rotating table 0.8 meters above the ground at a 3 meter semi-anechoic chamber. The table was rotated 360 degrees to determine the position of the highest radiation.
- b. The EUT was set 3 meters away from the interference-receiving antenna, which was mounted on the top of a variable-height antenna tower.
- c. The antenna is a broadband antenna, and its height is varied from one meter to four meters above the ground to determine the maximum value of the field strength. Both horizontal and vertical polarizations of the antenna are set to make the measurement.
- d. For each suspected emission, the EUT was arranged to its worst case and then the antenna was tuned to heights from 1 meter to 4 meters and the rotatable table was turned from 0 degrees to 360 degrees to find the maximum reading.
- e. The test-receiver system was set to Peak Detect Function and Specified Bandwidth with Maximum Hold Mode.
- f. If the emission level of the EUT in peak mode was lower than the limit specified, then testing could be stopped and the peak values of the EUT would be reported. Otherwise the emissions would be re-tested one by one using peak, quasi-peak or average method as specified and then reported in a data sheet.

**NOTE:**

1. The resolution bandwidth and video bandwidth of test receiver/spectrum analyzer is 120kHz for Quasi-peak detection at frequency below 1GHz.
2. The resolution bandwidth and video bandwidth of test receiver/spectrum analyzer is 1 MHz for Peak detection (PK) at frequency above 1GHz.

#### 4.2.4 DEVIATION FROM TEST STANDARD

No deviation

#### 4.2.5 TEST SETUP

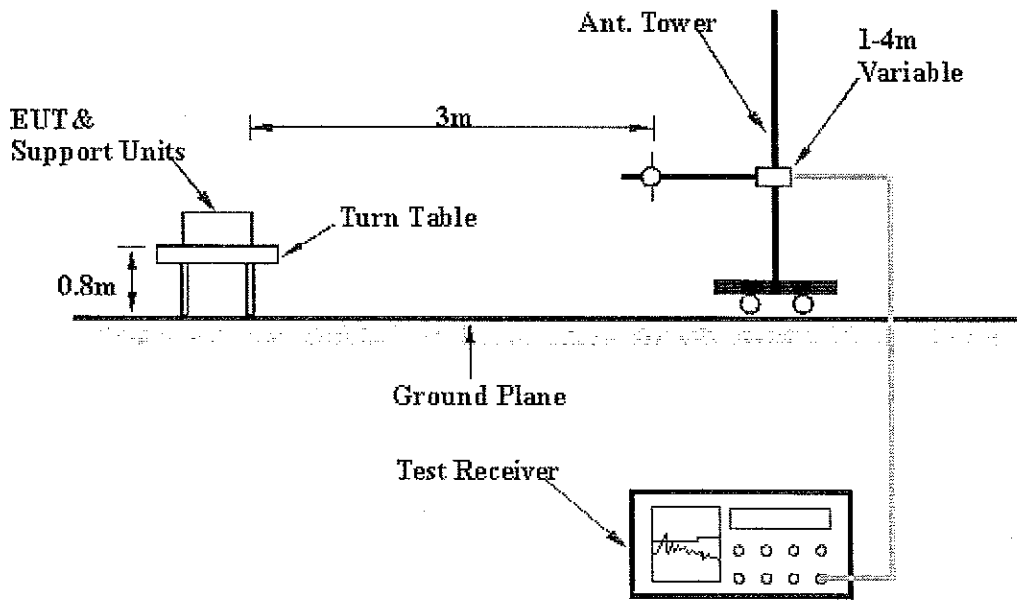

For the actual test configuration, please refer to the related item – Photographs of the Test Configuration.

#### 4.2.6 EUT OPERATING CONDITIONS

Same as 4.1.6





## 4.2.7 TEST RESULTS

RADIATED WORST CASE DATA: BELOW 1GHz

MODE A FOR GFSK

EUT TEST CONDITION		MEASUREMENT DETAIL	
CHANNEL	Channel 78	FREQUENCY RANGE	Below 1000MHz
MODULATION TYPE	GFSK	DETECTOR FUNCTION	Quasi-Peak
TEST MODE	A	ENVIRONMENTAL CONDITIONS	23deg. C, 62%RH, 991hPa
TESTED BY	Morgan Chen	INPUT POWER (SYSTEM)	120Vac, 60 Hz

ANTENNA POLARITY & TEST DISTANCE: HORIZONTAL AT 3 M								
No.	Freq. (MHz)	Emission Level (dBuV/m)	Limit (dBuV/m)	Margin (dB)	Antenna Height (m)	Table Angle (Degree)	Raw Value (dBuV)	Correction Factor (dB/m)
1	300.20	31.46 QP	46.00	-14.54	1.25 H	259	15.56	15.89
2	350.74	33.82 QP	46.00	-12.18	1.50 H	352	17.11	16.70
3	533.47	32.61 QP	46.00	-13.39	1.50 H	43	11.55	21.07
4	585.95	31.88 QP	46.00	-14.12	1.00 H	40	9.24	22.65
5	597.62	31.31 QP	46.00	-14.69	1.25 H	259	8.24	23.06
6	702.59	33.88 QP	46.00	-12.12	1.50 H	340	9.48	24.40

ANTENNA POLARITY & TEST DISTANCE: VERTICAL AT 3 M								
No.	Freq. (MHz)	Emission Level (dBuV/m)	Limit (dBuV/m)	Margin (dB)	Antenna Height (m)	Table Angle (Degree)	Raw Value (dBuV)	Correction Factor (dB/m)
1	55.27	25.78 QP	40.00	-14.22	1.00 V	187	11.85	13.93
2	479.04	35.25 QP	46.00	-10.75	1.00 V	151	15.32	19.93
3	500.42	32.18 QP	46.00	-13.82	1.00 V	175	11.71	20.48
4	533.47	36.16 QP	46.00	-9.84	1.00 V	175	15.09	21.07
5	585.95	33.20 QP	46.00	-12.80	1.00 V	97	10.56	22.65
6	599.56	31.81 QP	46.00	-14.19	1.00 V	175	8.68	23.13
7	702.59	35.71 QP	46.00	-10.29	1.00 V	76	11.31	24.40

- REMARKS:**
1. Emission level (dBuV/m) = Raw Value (dBuV) + Correction Factor (dB/m).
  2. Correction Factor (dB/m) = Antenna Factor (dB/m) + Cable Factor (dB).
  3. The other emission levels were very low against the limit.
  4. Margin value = Emission level – Limit value.



## MODE B FOR 8DPSK

EUT TEST CONDITION		MEASUREMENT DETAIL	
CHANNEL	Channel 78	FREQUENCY RANGE	Below 1000MHz
MODULATION TYPE	8DPSK	DETECTOR FUNCTION	Quasi-Peak
TEST MODE	B	ENVIRONMENTAL CONDITIONS	23deg. C, 62%RH, 991hPa
TESTED BY	Morgan Chen	INPUT POWER (SYSTEM)	120Vac, 60 Hz

ANTENNA POLARITY & TEST DISTANCE: HORIZONTAL AT 3 M								
No.	Freq. (MHz)	Emission Level (dBuV/m)	Limit (dBuV/m)	Margin (dB)	Antenna Height (m)	Table Angle (Degree)	Raw Value (dBuV)	Correction Factor (dB/m)
1	55.27	31.13 QP	40.00	-8.87	1.00 H	358	17.20	13.93
2	300.20	30.21 QP	46.00	-15.79	1.50 H	1	14.31	15.89
3	350.74	30.94 QP	46.00	-15.06	1.00 H	358	14.24	16.70
4	479.04	31.77 QP	46.00	-14.23	1.50 H	337	11.84	19.93
5	531.52	33.96 QP	46.00	-12.04	1.50 H	1	12.93	21.03
6	585.95	31.65 QP	46.00	-14.35	1.50 H	337	9.00	22.65
7	599.56	32.34 QP	46.00	-13.66	1.50 H	292	9.21	23.13
8	702.59	32.59 QP	46.00	-13.41	1.50 H	148	8.18	24.40
9	764.79	29.66 QP	46.00	-16.34	1.50 H	148	3.26	26.40
10	931.96	29.59 QP	46.00	-16.41	1.00 H	358	1.52	28.07

ANTENNA POLARITY & TEST DISTANCE: VERTICAL AT 3 M								
No.	Freq. (MHz)	Emission Level (dBuV/m)	Limit (dBuV/m)	Margin (dB)	Antenna Height (m)	Table Angle (Degree)	Raw Value (dBuV)	Correction Factor (dB/m)
1	57.21	28.17 QP	40.00	-11.83	1.00 V	10	14.43	13.75
2	142.75	26.84 QP	43.50	-16.66	1.00 V	247	13.49	13.35
3	479.04	34.86 QP	46.00	-11.14	1.00 V	319	14.93	19.93
4	500.42	30.43 QP	46.00	-15.57	1.00 V	352	9.95	20.48
5	533.47	36.92 QP	46.00	-9.08	1.00 V	352	15.85	21.07
6	585.95	31.98 QP	46.00	-14.02	1.00 V	10	9.33	22.65
7	599.56	29.29 QP	46.00	-16.71	1.00 V	352	6.16	23.13
8	702.59	34.47 QP	46.00	-11.53	1.00 V	352	10.07	24.40
9	764.79	29.53 QP	46.00	-16.47	1.00 V	352	3.12	26.40

- REMARKS:**
1. Emission level (dBuV/m) = Raw Value (dBuV) + Correction Factor (dB/m).
  2. Correction Factor (dB/m) = Antenna Factor (dB/m) + Cable Factor (dB).
  3. The other emission levels were very low against the limit.
  4. Margin value = Emission level – Limit value.



**RADIATED WORST CASE DATA: ABOVE 1GHz  
MODE A FOR GFSK**

EUT TEST CONDITION		MEASUREMENT DETAIL	
CHANNEL	Channel 0	FREQUENCY RANGE	1 ~ 25GHz
MODULATION TYPE	GFSK	DETECTOR FUNCTION	Peak (PK) Average (AV)
TEST MODE	A	ENVIRONMENTAL CONDITIONS	23deg. C, 62%RH, 991hPa
TESTED BY	Morgan Chen	INPUT POWER (SYSTEM)	120Vac, 60 Hz

ANTENNA POLARITY & TEST DISTANCE: HORIZONTAL AT 3 M								
No.	Freq. (MHz)	Emission Level (dBuV/m)	Limit (dBuV/m)	Margin (dB)	Antenna Height (m)	Table Angle (Degree)	Raw Value (dBuV)	Correction Factor (dB/m)
1	1602.00	50.00 PK	74.00	-24.00	1.00 H	229	20.87	29.13
1	1602.00	48.09 AV	54.00	-5.91	1.00 H	229	18.96	29.13
2	2390.00	45.74 PK	74.00	-28.26	1.00 H	341	13.83	31.91
2	2390.00	35.74 AV	54.00	-18.26	1.00 H	341	3.83	31.91
3	*2402.00	98.74 PK			1.00 H	341	66.76	31.98
3	*2402.00	68.74 AV			1.00 H	341	36.76	31.98
4	4804.00	67.87 PK	74.00	-6.13	1.02 H	11	30.38	37.49
4	4804.00	37.87 AV	54.00	-16.13	1.02 H	11	0.38	37.49

ANTENNA POLARITY & TEST DISTANCE: VERTICAL AT 3 M								
No.	Freq. (MHz)	Emission Level (dBuV/m)	Limit (dBuV/m)	Margin (dB)	Antenna Height (m)	Table Angle (Degree)	Raw Value (dBuV)	Correction Factor (dB/m)
1	1602.00	53.11 PK	74.00	-20.89	1.00 V	345	23.98	29.13
1	1602.00	51.99 AV	54.00	-2.01	1.00 V	345	22.86	29.13
2	2390.00	47.77 PK	74.00	-26.23	1.05 V	315	15.86	31.91
2	2390.00	37.77 AV	54.00	-16.23	1.05 V	315	5.86	31.91
3	*2402.00	100.77 PK	74.00		1.05 V	315	68.79	31.98
3	*2402.00	70.77 AV	54.00		1.05 V	315	38.79	31.98
4	4804.00	65.23 PK	74.00	-8.77	1.17 V	180	27.74	37.49
4	4804.00	35.23 AV	54.00	-18.77	1.17 V	180	-2.26	37.49

- REMARKS:**
1. Emission level (dBuV/m) = Raw Value (dBuV) + Correction Factor (dB/m).
  2. Correction Factor (dB/m) = Antenna Factor (dB/m) + Cable Factor (dB).
  3. The other emission levels were very low against the limit.
  4. Margin value = Emission level – Limit value.
  5. The DH5 packet was the worse case duty cycle for a transmit dwell time on a channel, based upon bluetooth theory the transmitter is on 0.625 \* 5 per 296.25 ms per channel. Therefore, the duty cycle be equal to:  $20\log(3.125/100) = -30$  dB.
  6. Average value = peak reading  $-20\log(\text{duty cycle})$ .



EUT TEST CONDITION		MEASUREMENT DETAIL	
CHANNEL	Channel 39	FREQUENCY RANGE	1 ~ 25GHz
MODULATION TYPE	GFSK	DETECTOR FUNCTION	Peak (PK) Average (AV)
TEST MODE	A	ENVIRONMENTAL CONDITIONS	23deg. C, 62%RH, 991hPa
TESTED BY	Morgan Chen	INPUT POWER (SYSTEM)	120Vac, 60 Hz

ANTENNA POLARITY & TEST DISTANCE: HORIZONTAL AT 3 M								
No.	Freq. (MHz)	Emission Level (dBuV/m)	Limit (dBuV/m)	Margin (dB)	Antenna Height (m)	Table Angle (Degree)	Raw Value (dBuV)	Correction Factor (dB/m)
1	1627.00	50.11 PK	74.00	-23.89	1.02 H	233	20.95	29.16
1	1627.00	48.13 AV	54.00	-5.87	1.02 H	233	18.97	29.16
2	*2441.00	98.85 PK			1.02 H	333	66.63	32.22
2	*2441.00	68.85 AV			1.02 H	333	36.63	32.22
3	4882.00	70.59 PK	74.00	-3.41	1.01 H	11	33.03	37.56
3	4882.00	40.59 AV	54.00	-13.41	1.01 H	11	3.03	37.56

ANTENNA POLARITY & TEST DISTANCE: VERTICAL AT 3 M								
No.	Freq. (MHz)	Emission Level (dBuV/m)	Limit (dBuV/m)	Margin (dB)	Antenna Height (m)	Table Angle (Degree)	Raw Value (dBuV)	Correction Factor (dB/m)
1	1627.00	52.86 PK	74.00	-21.14	1.00 V	344	23.70	29.16
1	1627.00	51.74 AV	54.00	-2.26	1.00 V	344	22.58	29.16
2	*2441.00	100.86 PK			1.03 V	322	68.64	32.22
2	*2441.00	70.86 AV			1.03 V	322	38.64	32.22
3	4882.00	68.33 PK	74.00	-5.67	1.13 V	178	30.77	37.56
3	4882.00	38.33 AV	54.00	-15.67	1.13 V	178	0.77	37.56

- REMARKS:**
1. Emission level (dBuV/m) = Raw Value (dBuV) + Correction Factor (dB/m).
  2. Correction Factor (dB/m) = Antenna Factor (dB/m) + Cable Factor (dB).
  3. The other emission levels were very low against the limit.
  4. Margin value = Emission level – Limit value.
  5. The DH5 packet was the worse case duty cycle for a transmit dwell time on a channel, based upon bluetooth theory the transmitter is on 0.625 \* 5 per 296.25 ms per channel. Therefore, the duty cycle be equal to:  $20\log(3.125/100) = -30$  dB.
  6. Average value = peak reading  $-20\log(\text{duty cycle})$ .



EUT TEST CONDITION		MEASUREMENT DETAIL	
CHANNEL	Channel 78	FREQUENCY RANGE	1 ~ 25GHz
MODULATION TYPE	GFSK	DETECTOR FUNCTION	Peak (PK) Average (AV)
TEST MODE	A	ENVIRONMENTAL CONDITIONS	23deg. C, 62%RH, 991hPa
TESTED BY	Morgan Chen	INPUT POWER (SYSTEM)	120Vac, 60 Hz

ANTENNA POLARITY & TEST DISTANCE: HORIZONTAL AT 3 M								
No.	Freq. (MHz)	Emission Level (dBuV/m)	Limit (dBuV/m)	Margin (dB)	Antenna Height (m)	Table Angle (Degree)	Raw Value (dBuV)	Correction Factor (dB/m)
1	1653.00	50.55 PK	74.00	-23.45	1.01 H	241	21.37	29.18
1	1653.00	48.58 AV	54.00	-5.42	1.01 H	241	19.40	29.18
2	*2480.00	98.99 PK			1.05 H	318	66.52	32.47
2	*2480.00	68.99 AV			1.05 H	318	36.52	32.47
3	2483.50	45.99 PK	74.00	-28.01	1.05 H	318	13.50	32.49
3	2483.50	35.99 AV	54.00	-18.01	1.05 H	318	3.50	32.49
4	4960.00	71.11 PK	74.00	-2.89	1.02 H	16	33.52	37.59
4	4960.00	41.11 AV	54.00	-12.89	1.02 H	16	3.52	37.59

ANTENNA POLARITY & TEST DISTANCE: VERTICAL AT 3 M								
No.	Freq. (MHz)	Emission Level (dBuV/m)	Limit (dBuV/m)	Margin (dB)	Antenna Height (m)	Table Angle (Degree)	Raw Value (dBuV)	Correction Factor (dB/m)
1	1653.00	52.97 PK	74.00	-21.03	1.00 V	328	23.79	29.18
1	1653.00	51.86 AV	54.00	-2.14	1.00 V	328	22.68	29.18
2	*2480.00	101.12 PK			1.05 V	318	68.65	32.47
2	*2480.00	71.12 AV			1.05 V	318	38.65	32.47
3	2483.50	48.12 PK	74.00	-25.88	1.05 V	318	15.63	32.49
3	2483.50	38.12 AV	54.00	-15.88	1.05 V	318	5.63	32.49
4	4960.00	68.55 PK	74.00	-5.45	1.11 V	169	30.96	37.59
4	4960.00	38.55 AV	54.00	-15.45	1.11 V	169	0.96	37.59

- REMARKS:**
1. Emission level (dBuV/m) = Raw Value (dBuV) + Correction Factor (dB/m).
  2. Correction Factor (dB/m) = Antenna Factor (dB/m) + Cable Factor (dB).
  3. The other emission levels were very low against the limit.
  4. Margin value = Emission level – Limit value.
  5. The DH5 packet was the worse case duty cycle for a transmit dwell time on a channel, based upon bluetooth theory the transmitter is on 0.625 \* 5 per 296.25 ms per channel. Therefore, the duty cycle be equal to:  $20\log(3.125/100) = -30$  dB.
  6. Average value = peak reading  $-20\log(\text{duty cycle})$ .



## MODE B FOR 8DPSK

EUT TEST CONDITION		MEASUREMENT DETAIL	
CHANNEL	Channel 0	FREQUENCY RANGE	1 ~ 25GHz
MODULATION TYPE	8DPSK	DETECTOR FUNCTION	Peak (PK) Average (AV)
TEST MODE	B	ENVIRONMENTAL CONDITIONS	23deg. C, 62%RH, 991hPa
TESTED BY	Morgan Chen	INPUT POWER (SYSTEM)	120Vac, 60 Hz

## ANTENNA POLARITY &amp; TEST DISTANCE: HORIZONTAL AT 3 M

No.	Freq. (MHz)	Emission Level (dBuV/m)	Limit (dBuV/m)	Margin (dB)	Antenna Height (m)	Table Angle (Degree)	Raw Value (dBuV)	Correction Factor (dB/m)
1	1602.00	48.22 PK	74.00	-25.78	1.00 H	218	19.09	29.13
1	1602.00	46.12 AV	54.00	-7.88	1.00 H	218	16.99	29.13
2	2390.00	38.22 PK	74.00	-35.78	1.16 H	35	6.31	31.91
2	2390.00	28.22 AV	54.00	-25.78	1.16 H	35	-3.69	31.91
3	*2402.00	93.97 PK			1.16 H	35	61.99	31.98
3	*2402.00	63.97 AV			1.16 H	35	31.99	31.98
4	4804.00	58.88 PK	74.00	-15.12	1.03 H	18	21.39	37.49
4	4804.00	28.88 AV	54.00	-25.12	1.03 H	18	-8.61	37.49

## ANTENNA POLARITY &amp; TEST DISTANCE: VERTICAL AT 3 M

No.	Freq. (MHz)	Emission Level (dBuV/m)	Limit (dBuV/m)	Margin (dB)	Antenna Height (m)	Table Angle (Degree)	Raw Value (dBuV)	Correction Factor (dB/m)
1	1602.00	51.53 PK	74.00	-22.47	1.00 V	349	22.40	29.13
1	1602.00	49.82 AV	54.00	-4.18	1.00 V	349	20.69	29.13
2	2390.00	41.56 PK	74.00	-32.44	1.00 V	2	9.65	31.91
2	2390.00	31.56 AV	54.00	-22.44	1.00 V	2	-0.35	31.91
3	*2402.00	96.56 PK			1.00 V	2	64.58	31.98
3	*2402.00	66.56 AV			1.00 V	2	34.58	31.98
4	4804.00	56.77 PK	74.00	-17.23	1.05 V	161	19.28	37.49
4	4804.00	26.77 AV	54.00	-27.23	1.05 V	161	-10.72	37.49

- REMARKS:**
1. Emission level (dBuV/m) = Raw Value (dBuV) + Correction Factor (dB/m).
  2. Correction Factor (dB/m) = Antenna Factor (dB/m) + Cable Factor (dB).
  3. The other emission levels were very low against the limit.
  4. Margin value = Emission level – Limit value.
  5. The DH5 packet was the worse case duty cycle for a transmit dwell time on a channel, based upon bluetooth theory the transmitter is on 0.625 \* 5 per 296.25 ms per channel. Therefore, the duty cycle be equal to:  $20\log(3.125/100) = -30$  dB.
  6. Average value = peak reading  $-20\log(\text{duty cycle})$ .



EUT TEST CONDITION		MEASUREMENT DETAIL	
CHANNEL	Channel 39	FREQUENCY RANGE	1 ~ 25GHz
MODULATION TYPE	8DPSK	DETECTOR FUNCTION	Peak (PK) Average (AV)
TEST MODE	B	ENVIRONMENTAL CONDITIONS	23deg. C, 62%RH, 991hPa
TESTED BY	Morgan Chen	INPUT POWER (SYSTEM)	120Vac, 60 Hz

ANTENNA POLARITY & TEST DISTANCE: HORIZONTAL AT 3 M								
No.	Freq. (MHz)	Emission Level (dBuV/m)	Limit (dBuV/m)	Margin (dB)	Antenna Height (m)	Table Angle (Degree)	Raw Value (dBuV)	Correction Factor (dB/m)
1	1627.00	48.35 PK	74.00	-25.65	1.14 H	25	19.19	29.16
1	1627.00	46.38 AV	54.00	-7.62	1.14 H	25	17.22	29.16
2	*2441.00	94.12 PK			1.12 H	32	61.90	32.22
2	*2441.00	64.12 AV			1.12 H	32	31.90	32.22
3	4882.00	58.98 PK	74.00	-15.02	1.05 H	12	21.42	37.56
3	4882.00	28.98 AV	54.00	-25.02	1.05 H	12	-8.58	37.56

ANTENNA POLARITY & TEST DISTANCE: VERTICAL AT 3 M								
No.	Freq. (MHz)	Emission Level (dBuV/m)	Limit (dBuV/m)	Margin (dB)	Antenna Height (m)	Table Angle (Degree)	Raw Value (dBuV)	Correction Factor (dB/m)
1	1627.00	51.81 PK	74.00	-22.19	1.02 V	311	22.65	29.16
1	1627.00	49.98 AV	54.00	-4.02	1.02 V	311	20.82	29.16
2	*2441.00	96.78 PK			1.00 V	5	64.56	32.22
2	*2441.00	66.78 AV			1.00 V	5	34.56	32.22
3	4882.00	56.89 PK	74.00	-17.11	1.01 V	158	19.33	37.56
3	4882.00	26.89 AV	54.00	-27.11	1.01 V	158	-10.67	37.56

- REMARKS:**
1. Emission level (dBuV/m) = Raw Value (dBuV) + Correction Factor (dB/m).
  2. Correction Factor (dB/m) = Antenna Factor (dB/m) + Cable Factor (dB).
  3. The other emission levels were very low against the limit.
  4. Margin value = Emission level – Limit value.
  5. The DH5 packet was the worse case duty cycle for a transmit dwell time on a channel, based upon bluetooth theory the transmitter is on 0.625 \* 5 per 296.25 ms per channel. Therefore, the duty cycle be equal to:  $20\log(3.125/100) = -30$  dB.
  6. Average value = peak reading  $-20\log(\text{duty cycle})$ .



EUT TEST CONDITION		MEASUREMENT DETAIL	
CHANNEL	Channel 78	FREQUENCY RANGE	1 ~ 25GHz
MODULATION TYPE	8DPSK	DETECTOR FUNCTION	Peak (PK) Average (AV)
TEST MODE	B	ENVIRONMENTAL CONDITIONS	23deg. C, 62%RH, 991hPa
TESTED BY	Morgan Chen	INPUT POWER (SYSTEM)	120Vac, 60 Hz

ANTENNA POLARITY & TEST DISTANCE: HORIZONTAL AT 3 M								
No.	Freq. (MHz)	Emission Level (dBuV/m)	Limit (dBuV/m)	Margin (dB)	Antenna Height (m)	Table Angle (Degree)	Raw Value (dBuV)	Correction Factor (dB/m)
1	1653.00	48.35 PK	74.00	-25.65	1.02 H	255	19.17	29.18
1	1653.00	46.20 AV	54.00	-7.80	1.02 H	255	17.02	29.18
2	*2480.00	94.55 PK			1.13 H	25	62.08	32.47
2	*2480.00	64.55 AV			1.13 H	25	32.08	32.47
3	2483.50	48.55 PK	74.00	-25.45	1.13 H	25	16.06	32.49
3	2483.50	38.55 AV	54.00	-15.45	1.13 H	25	6.06	32.49
4	4960.00	59.22 PK	74.00	-14.78	1.13 H	11	21.63	37.59
4	4960.00	29.22 AV	54.00	-24.78	1.13 H	11	-8.37	37.59

ANTENNA POLARITY & TEST DISTANCE: VERTICAL AT 3 M								
No.	Freq. (MHz)	Emission Level (dBuV/m)	Limit (dBuV/m)	Margin (dB)	Antenna Height (m)	Table Angle (Degree)	Raw Value (dBuV)	Correction Factor (dB/m)
1	1653.00	51.95 PK	74.00	-22.05	1.00 V	351	22.77	29.18
1	1653.00	50.01 AV	54.00	-3.99	1.00 V	351	20.83	29.18
2	*2480.00	96.89 PK			1.00 V	8	64.42	32.47
2	*2480.00	66.89 AV			1.00 V	8	34.42	32.47
3	2483.50	50.01 PK	74.00	-23.99	1.00 V	8	17.52	32.49
3	2483.50	40.01 AV	54.00	-13.99	1.00 V	8	7.52	32.49
4	4960.00	56.98 PK	74.00	-17.02	1.01 V	158	19.39	37.59
4	4960.00	29.98 AV	54.00	-24.02	1.01 V	158	-7.61	37.59

- REMARKS:**
1. Emission level (dBuV/m) = Raw Value (dBuV) + Correction Factor (dB/m).
  2. Correction Factor (dB/m) = Antenna Factor (dB/m) + Cable Factor (dB).
  3. The other emission levels were very low against the limit.
  4. Margin value = Emission level – Limit value.
  5. The DH5 packet was the worse case duty cycle for a transmit dwell time on a channel, based upon bluetooth theory the transmitter is on 0.625 \* 5 per 296.25 ms per channel. Therefore, the duty cycle be equal to:  $20\log(3.125/100) = -30$  dB.
  6. Average value = peak reading  $-20\log(\text{duty cycle})$ .