

NOTES:

1. Material: Polycarbonate T= 0.127mm with matted texture
2. Material must be approved by UL, CSA
3. Adhesive Spec Refer to ES-811-RO5 Sony 303 or Toyo Df2700MR or Equiv
4. Print Color: Letters Silver ACD M808
Background Black ACD-M8010 and cool gray 11
5. Print Tolerance of dimensions +0.3/.03

REVISIONS				
ZONE	REV.	DESCRIPTION	DATE	APPROVED

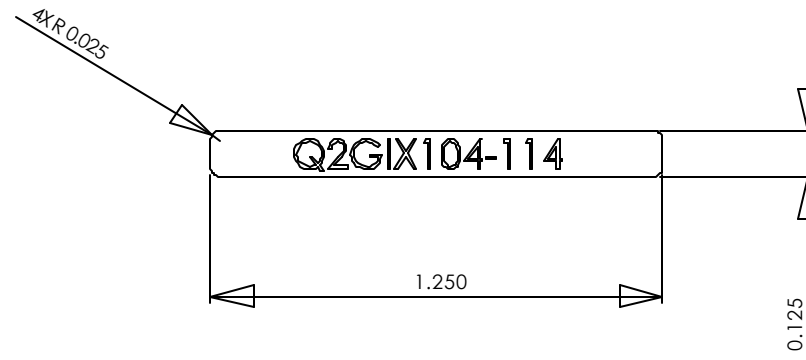

PROPRIETARY AND CONFIDENTIAL
 THE INFORMATION CONTAINED IN THIS DRAWING IS THE SOLE PROPERTY OF XPLORE TECHNOLOGIES. ANY REPRODUCTION IN PART OR AS A WHOLE WITHOUT THE WRITTEN PERMISSION OF XPLORE TECHNOLOGIES IS PROHIBITED.

		DIMENSIONS ARE IN INCHES		NAME		DATE		Xplore Technologies	
		TOLERANCES:		DRAWN					
		FRACTIONAL ±		CHECKED				LABEL, IX104, WIRELESS, KN8	
		ANGULAR: MACH ± BEND ±		ENG APPR.					
		TWO PLACE DECIMAL ±		MFG APPR.					
		THREE PLACE DECIMAL ±		Q.A.					
		MATERIAL --		COMMENTS:					
NEXT ASSY	USED ON	FINISH --							
APPLICATION		DO NOT SCALE DRAWING							
				SIZE A		DWG. NO. 50-23042		REV. A	
				SCALE: 2:1		WEIGHT:		SHEET 1 OF 1	

