

Configuration Label Placement



NOTE: This label will be placed under the battery.

NOTES:

1. Material: Polycarbonate T= 0.127mm with matted texture
2. Material must be approved by UL, CSA
3. Adhesive Spec Refer to ES-811-RO5 Sony 303 or Toyo DF2700MR or Equiv
4. Print Color: Letters Black, Background cool gray 11
5. Print Tolerance of dimensions +0.3/.03

		REVISIONS		
ECO	REV.	DESCRIPTION		DATE
	A	Initial Release		11/16/2010

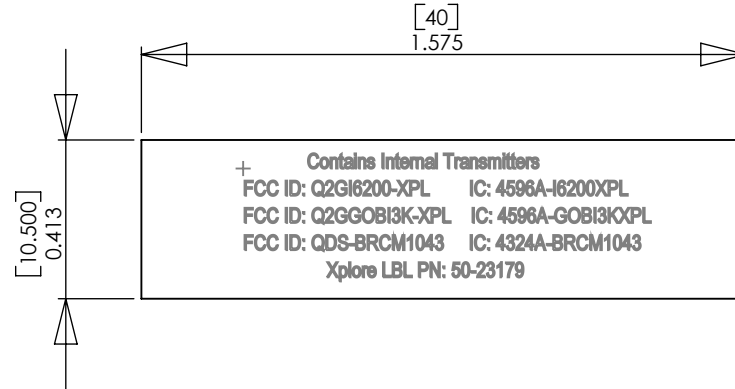

PROPRIETARY AND CONFIDENTIAL
 THE INFORMATION CONTAINED IN THIS DRAWING IS THE SOLE PROPERTY OF XPLORE TECHNOLOGIES. ANY REPRODUCTION IN PART OR AS A WHOLE WITHOUT THE WRITTEN PERMISSION OF XPLORE TECHNOLOGIES IS PROHIBITED.

		DIMENSIONS ARE IN INCHES		NAME		DATE		Xplore Technologies		
		TOLERANCES:		DRAWN RvES		11/16/10				
		FRACTIONAL ±		CHECKED				LABEL, CONFIG FCC, I6200 + GOBI3000		
		ANGULAR: MACH ± BEND ±		ENG APPR.						
		TWO PLACE DECIMAL ±		MFG APPR.						
		THREE PLACE DECIMAL ±		Q.A.						
		MATERIAL --		COMMENTS:						
		FINISH --								
NEXT ASSY	USED ON							SIZE	DWG. NO.	REV.
APPLICATION		DO NOT SCALE DRAWING						A	50-23179	A
								SCALE:5:1	WEIGHT:	SHEET 1 OF 1

Intel 6205 a/b/g/n and GOBI3000 Configuration Label

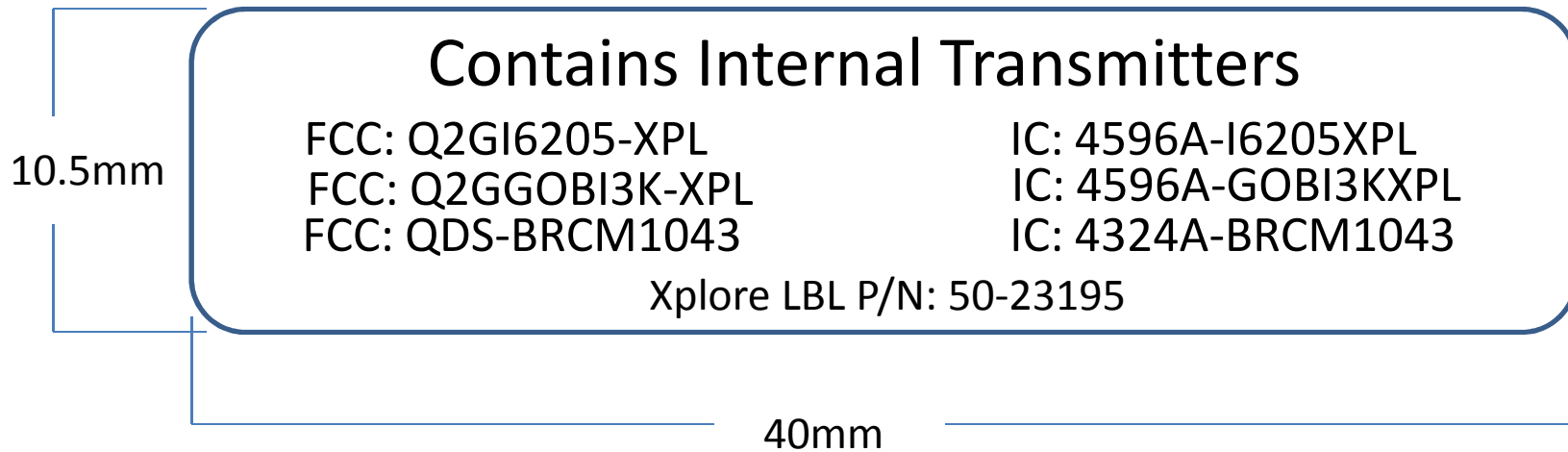

1. *MATERIAL: 0.127mm Velvet Lexan + 3M467*
2. *FINISH: PRINT FRONT SIDE , ADHESIVE BACK*
3. *COLOR: BACKGROUND -- PANTONE BLACK C*
4. *LETTERS -----PANTONE COOL GRAY 6C*
5. *PRINTING TOLERANCE OF DIMENSION ARE +0.3/-0.3mm*

NOTE: This label will be placed under the battery. The BT is standard and does not require labeling.

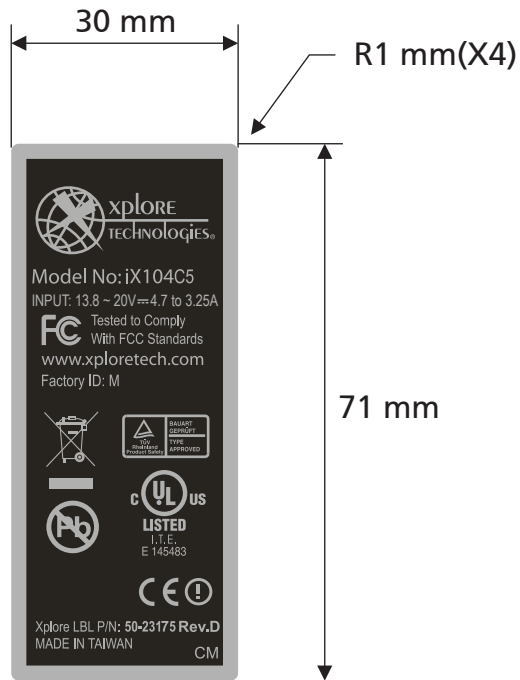

Pantone Cool Gray 6 C

Pantone Black C

Wistron Corporation

MODEL NO.: WILDCAT5
 PART NAME: MAIN REGULATORY LBL SCALE: 1 : 1
 A/W NO.: 40.4JP11.001 SHEET 1 OF 1

REV	DESCRIPTION	SIGN DATE
-----	-------------	-----------

- 1.MATERIAL: 0.127mm Velvet Lexan + 3M467
- 2.FINISH: PRINT FRONT SIDE , ADHESIVE BACK
- 3.COLOR: BACKGROUND -- PANTONE BLACK C
LETTERS -----PANTONE COOL GRAY 6C
- 4.PRINTING TOLERANCE OF DIMENSION ARE +0.3/-0.3mm

MVDG00
 Vicki Jan
 DRAWN: 10/21/2010 REVIEWED: _____ APPROVED: _____

GOBI3000 Card Label



1. Material: Polycarbonate T= 0.127mm with matted texture
2. Material must be approved by UL, CSA
3. Adhesive Spec Refer to ES-811-RO5 Sony 303 or Toyo Df2700MR or Equiv
4. Print Color: Letters Black, Background White
5. Print Tolerance of dimensions +0.3/.03

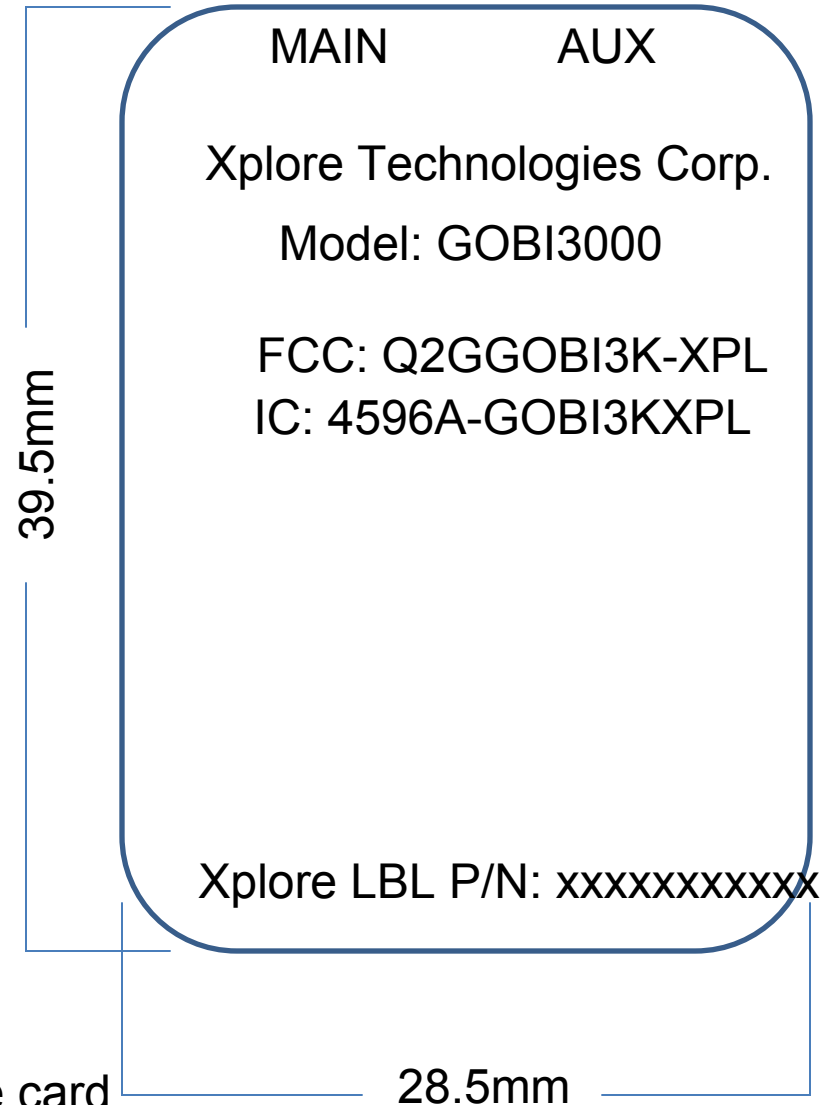

NOTE: This label will be adhered to the card

28.5mm