

**NOTES:**

1. Material: Polycarbonate T= 0.127mm with matted texture
2. Material must be approved by UL, CSA
3. Adhesive Spec Refer to ES-811-RO5 Sony 303 or Toyo DF2700MR or Equiv
4. Print Color: Letters Black, Background cool gray 11
5. Print Tolerance of dimensions +0.3/.03

		REVISIONS	DATE
ECO	REV.	DESCRIPTION	
	A	Initial Release	11/16/2010

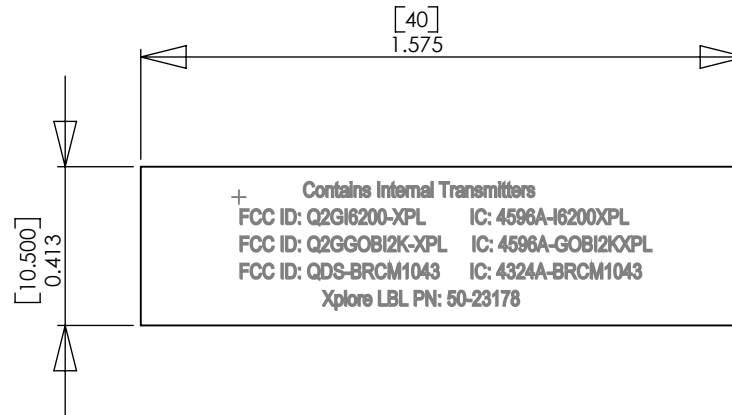

**PROPRIETARY AND CONFIDENTIAL**  
 THE INFORMATION CONTAINED IN THIS DRAWING IS THE SOLE PROPERTY OF XPLORE TECHNOLOGIES. ANY REPRODUCTION IN PART OR AS A WHOLE WITHOUT THE WRITTEN PERMISSION OF XPLORE TECHNOLOGIES IS PROHIBITED.

		DIMENSIONS ARE IN INCHES		NAME	DATE	Xplore Technologies
		TOLERANCES:		DRAWN	RVES	
		FRACTIONAL ±		CHECKED		LABEL, CONFIG FCC, I6200 + G0BI2000
		ANGULAR: MACH ± BEND ±		ENG APPR.		
		TWO PLACE DECIMAL ±		MFG APPR.		
		THREE PLACE DECIMAL ±		Q.A.		
		MATERIAL --		COMMENTS:		
NEXT ASSY	USED ON	FINISH --				
APPLICATION		DO NOT SCALE DRAWING				SIZE DWG. NO. REV. A 50-23178 A
				SCALE:5:1	WEIGHT:	SHEET 1 OF 1