

FCC SAR Test Report

APPLICANT : Xplore Technologies Corp.
EQUIPMENT : Wireless Modules
BRAND NAME : Xplore Technologies
MODEL NAME : EM7355
FCC ID : Q2GEM7355B
STANDARD : FCC 47 CFR Part 2 (2.1093)
ANSI/IEEE C95.1-1992
IEEE 1528-2003

The product was installed into Rugged Tablet PC (Brand Name: Xplore Technologies Corp, Model Name: iX101B2) during test.

We, SPORTON INTERNATIONAL INC., would like to declare that the tested sample has been evaluated in accordance with the procedures and had been in compliance with the applicable technical standards.

The test results in this report apply exclusively to the tested model / sample. Without written approval of SPORTON INTERNATIONAL INC., the test report shall not be reproduced except in full.

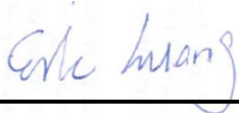

Reviewed by: Eric Huang / Deputy Manager



Approved by: Jones Tsai / Manager



SPORTON INTERNATIONAL INC.

No.52, Hwa Ya 1st Rd., Hwa Ya Technology Park, Kwei-Shan District, Taoyuan City, Taiwan (R.O.C.)



Table of Contents

1. Statement of Compliance 4

2. Administration Data 4

3. Guidance Standard 5

4. Equipment Under Test (EUT) 5

 4.1 General Information 5

 4.2 Maximum Tune-up Limit..... 6

 4.3 General LTE SAR Test and Reporting Considerations 9

5. Proximity Sensor Triggering Test.....11

6. RF Exposure Limits.....14

 6.1 Uncontrolled Environment.....14

 6.2 Controlled Environment.....14

7. Specific Absorption Rate (SAR).....15

 7.1 Introduction 15

 7.2 SAR Definition.....15

8. System Description and Setup16

9. Measurement Procedures17

 9.1 Spatial Peak SAR Evaluation.....17

 9.2 Power Reference Measurement.....18

 9.3 Area Scan18

 9.4 Zoom Scan.....19

 9.5 Volume Scan Procedures.....19

 9.6 Power Drift Monitoring.....19

10. Test Equipment List.....20

11. System Verification21

 11.1 Tissue Verification21

 11.2 System Performance Check Results22

12. RF Exposure Positions22

 12.1 SAR Testing for Tablet.....22

13. Conducted RF Output Power (Unit: dBm).....23

14. Antenna Location50

15. SAR Test Results52

 15.1 Body SAR53

 15.2 Repeated SAR Measurement57

16. Simultaneous Transmission Analysis.....58

 16.1 Body Exposure Conditions.....59

 16.2 SPLSR Evaluation and Analysis.....69

17. Uncertainty Assessment72

18. References74

Appendix A. Plots of System Performance Check

Appendix B. Plots of High SAR Measurement

Appendix C. DASY Calibration Certificate

Appendix D. Test Setup Photos



1. Statement of Compliance

The maximum results of Specific Absorption Rate (SAR) found during testing for **Xplore Technologies Corp., Wireless Modules, EM7355**, are as follows.

Equipment Class	Frequency Band	Highest SAR Summary	
		Body 1g SAR (W/kg)	Simultaneous Transmission 1g SAR (W/kg)
PCB	GSM850	0.91	1.59
	GSM1900	1.08	
	WCDMA Band V	0.90	
	WCDMA Band IV	0.91	
	WCDMA Band II	0.99	
	CDMA 2000 BC10	0.85	
	CDMA 2000 BC0	1.04	
	CDMA 2000 BC1	0.87	
	LTE Band 17	0.76	
	LTE Band 13	0.63	
	LTE Band 5	0.99	
	LTE Band 4	1.03	
	LTE Band 2	1.06	
	LTE Band 25	1.07	
Date of Testing:		2015/02/18 ~ 2015/02/24	

This device is in compliance with Specific Absorption Rate (SAR) for general population/uncontrolled exposure limits (1.6 W/kg) specified in FCC 47 CFR part 2 (2.1093) and ANSI/IEEE C95.1-1992, and had been tested in accordance with the measurement methods and procedures specified in IEEE 1528-2003.

2. Administration Data

Testing Laboratory	
Test Site	SPORTON INTERNATIONAL INC.
Test Site Location	No.52, Hwa Ya 1st Rd., Hwa Ya Technology Park, Kwei-Shan District, Taoyuan City, Taiwan (R.O.C.) TEL: +886-3-327-3456 FAX: +886-3-328-4978

Applicant	
Company Name	Xplore Technologies Corp.
Address	14000 Summit Road Suite 900, Austin, Texas, 78728 USA

Manufacturer	
Company Name	Sierra Wireless Inc.
Address	13811, Wireless Way, Richmond, British Columbia, Canada



3. Guidance Standard

The Specific Absorption Rate (SAR) testing specification, method, and procedure for this device is in accordance with the following standards:

- FCC 47 CFR Part 2 (2.1093)
- ANSI/IEEE C95.1-1992
- IEEE 1528-2003
- FCC KDB 865664 D01 SAR Measurement 100 MHz to 6 GHz v01r03
- FCC KDB 865664 D02 SAR Reporting v01r01
- FCC KDB 447498 D01 General RF Exposure Guidance v05r02
- FCC KDB 616217 D04 SAR for laptop and tablets v01r01
- FCC KDB 941225 D01 3G SAR Procedures v03
- FCC KDB 941225 D05 SAR for LTE Devices v02r03

4. Equipment Under Test (EUT)

4.1 General Information

Product Feature & Specification	
Equipment Name	Wireless Modules
Brand Name	Xplore Technologies
Model Name	EM7355
FCC ID	Q2GEM7355B
IMEI Code	356196050715024
Wireless Technology and Frequency Range	GSM850: 824.2 MHz ~ 848.8 MHz GSM1900: 1850.2 MHz ~ 1909.8 MHz WCDMA Band V: 826.4 MHz ~ 846.6 MHz WCDMA Band IV: 1712.4 MHz ~ 1752.6 MHz WCDMA Band II: 1852.4 MHz ~ 1907.6 MHz CDMA2000 BC0: 824.7 MHz ~ 848.31 MHz CDMA 2000 BC10: 817.9 MHz ~ 823.1 MHz CDMA 2000 BC1: 1851.25 MHz ~ 1908.75 MHz LTE Band 17: 706.5 MHz ~ 713.5 MHz LTE Band 13: 779.5 MHz ~ 784.5 MHz LTE Band 5: 824.7 MHz ~ 848.3 MHz LTE Band 4: 1710.7 MHz ~ 1754.3 MHz LTE Band 2: 1850.7 MHz ~ 1909.3 MHz LTE Band 25: 1850.7 MHz ~ 1914.3 MHz
Mode	<ul style="list-style-type: none"> • GPRS/EGPRS • RMC 12.2Kbps • HSDPA • HSUPA • DC-HSDPA • CDMA2000: 1xRTT/1xEv-Do(Rev.0)/1xEv-Do(Rev.A) • LTE: QPSK, 16QAM
EUT Stage	Production Unit
Remark:	1. The WLAN/BT module, Intel 7265NGW, FCC ID: Q2G7265NG is also integrated into this host and the WLAN and Bluetooth SAR testing results are also used perform transmission simultaneous analysis which can be referred to RF Exposure Lab SAR Evaluation Report, Report No: FA520236-01.



Host Information	
Host Name	Rugged Tablet PC
Brand Name	Xplore Technologies Corp
Model Name	iX101B2
Wireless Technology and Frequency Range	WLAN 2.4GHz Band: 2412 MHz ~ 2462 MHz WLAN 5.2GHz Band: 5180 MHz ~ 5240 MHz WLAN 5.3GHz Band: 5260 MHz ~ 5320 MHz WLAN 5.5GHz Band: 5500 MHz ~ 5700 MHz WLAN 5.8GHz Band: 5745 MHz ~ 5825 MHz Bluetooth: 2402 MHz ~ 2480 MHz
Mode	• 802.11a/b/g/n/ac HT20/HT40/VHT20/VHT40/VHT80 • Bluetooth v3.0+EDR • Bluetooth v4.0 LE
Antenna Type	WWAN: PIFA Antenna WLAN: PIFA Antenna Bluetooth: PIFA Antenna

4.2 Maximum Tune-up Limit

Mode / Band	Burst Average Power (dBm)			
	GSM 850		GSM 1900	
	Full Power Mode	Reduce Power Mode	Full Power Mode	Reduce Power Mode
Output Power Status				
GPRS (GMSK, 1 Tx slot)	33.50	30.00	30.50	29.00
GPRS (GMSK, 2 Tx slots)	33.00	27.00	30.00	26.00
EDGE (8PSK, 1 Tx slot)	28.00	28.00	27.00	27.00
EDGE (8PSK, 2 Tx slots)	27.00	26.00	26.00	25.00
EDGE (8PSK, 3 Tx slot)	27.00	24.00	26.00	23.00
EDGE (8PSK, 4 Tx slots)	27.00	23.00	26.00	22.00

Mode / Band	Average Power (dBm)					
	WCDMA Band V		WCDMA Band II		WCDMA Band IV	
	Full Power Mode	Reduce Power Mode	Full Power Mode	Reduce Power Mode	Full Power Mode	Reduce Power Mode
Output Power Status						
RMC 12.2Kbps	24.00	20.00	24.00	20.00	24.00	18.00
HSDPA Subtest-1	24.00	20.00	24.00	20.00	24.00	18.00
DC-HSDPA Subtest-1	24.00	20.00	24.00	20.00	24.00	18.00
HSUPA Subtest-5	24.00	20.00	24.00	20.00	24.00	18.00

Mode / Band	Average Power (dBm)					
	CDMA BC10		CDMA BC0		CDMA BC1	
	Full Power Mode	Reduce Power Mode	Full Power Mode	Reduce Power Mode	Full Power Mode	Reduce Power Mode
Output Power Status						
1xRTT RC1 SO55	24.50	21.00	24.50	21.00	24.50	20.00
1xRTT RC3 SO55	24.50	21.00	24.50	21.00	24.50	20.00
1xEV-DO Rev 0	24.50	21.00	24.50	21.00	24.50	20.00
1xEV-DO Rev A	24.50	21.00	24.50	21.00	24.50	20.00

LTE Band 17						
Modulation	BW (MHz)	RB size	Full Power Mode		Reduce Power Mode	
			MPR	Average Power (dBm)	MPR	Average Power (dBm)
QPSK	10	≤ 12	0	24.00	0	23.00
QPSK	10	> 12	1	23.00	0	23.00
16QAM	10	≤ 12	1	23.00	0	23.00
16QAM	10	> 12	2	22.00	0	23.00
QPSK	5	≤ 8	0	24.00	0	23.00
QPSK	5	> 8	1	23.00	0	23.00
16QAM	5	≤ 8	1	23.00	0	23.00
16QAM	5	> 8	2	22.00	0	23.00



LTE Band 13						
Modulation	BW (MHz)	RB size	Full Power Mode		Reduce Power Mode	
			MPR	Average Power (dBm)	MPR	Average Power (dBm)
QPSK	10	≤ 12	0	24.00	0	21.00
QPSK	10	> 12	1	23.00	0	21.00
16QAM	10	≤ 12	1	23.00	0	21.00
16QAM	10	> 12	2	22.00	0	21.00
QPSK	5	≤ 8	0	24.00	0	21.00
QPSK	5	> 8	1	23.00	0	21.00
16QAM	5	≤ 8	1	23.00	0	21.00
16QAM	5	> 8	2	22.00	0	21.00

LTE Band 5						
Modulation	BW (MHz)	RB size	Full Power Mode		Reduce Power Mode	
			MPR	Average Power (dBm)	MPR	Average Power (dBm)
QPSK	10	≤ 12	0	24.00	0	20.00
QPSK	10	> 12	1	23.00	0	20.00
16QAM	10	≤ 12	1	23.00	0	20.00
16QAM	10	> 12	2	22.00	0	20.00
QPSK	5	≤ 8	0	24.00	0	20.00
QPSK	5	> 8	1	23.00	0	20.00
16QAM	5	≤ 8	1	23.00	0	20.00
16QAM	5	> 8	2	22.00	0	20.00

LTE Band 4						
Modulation	BW (MHz)	RB size	Full Power Mode		Reduce Power Mode	
			MPR	Average Power (dBm)	MPR	Average Power (dBm)
QPSK	20	≤ 18	0	24.00	0	18.00
QPSK	20	> 18	1	23.00	0	18.00
16QAM	20	≤ 18	1	23.00	0	18.00
16QAM	20	> 18	2	22.00	0	18.00
QPSK	15	≤ 16	0	24.00	0	18.00
QPSK	15	> 16	1	23.00	0	18.00
16QAM	15	≤ 16	1	23.00	0	18.00
16QAM	15	> 16	2	22.00	0	18.00
QPSK	10	≤ 12	0	24.00	0	18.00
QPSK	10	> 12	1	23.00	0	18.00
16QAM	10	≤ 12	1	23.00	0	18.00
16QAM	10	> 12	2	22.00	0	18.00
QPSK	5	≤ 8	0	24.00	0	18.00
QPSK	5	> 8	1	23.00	0	18.00
16QAM	5	≤ 8	1	23.00	0	18.00
16QAM	5	> 8	2	22.00	0	18.00



LTE Band 2						
Modulation	BW (MHz)	RB size	Full Power Mode		Reduce Power Mode	
			MPR	Average Power (dBm)	MPR	Average Power (dBm)
QPSK	20	≤ 18	0	24.00	0	20.00
QPSK	20	> 18	1	23.00	0	20.00
16QAM	20	≤ 18	1	23.00	0	20.00
16QAM	20	> 18	2	22.00	0	20.00
QPSK	15	≤ 16	0	24.00	0	20.00
QPSK	15	> 16	1	23.00	0	20.00
16QAM	15	≤ 16	1	23.00	0	20.00
16QAM	15	> 16	2	22.00	0	20.00
QPSK	10	≤ 12	0	24.00	0	20.00
QPSK	10	> 12	1	23.00	0	20.00
16QAM	10	≤ 12	1	23.00	0	20.00
16QAM	10	> 12	2	22.00	0	20.00
QPSK	5	≤ 8	0	24.00	0	20.00
QPSK	5	> 8	1	23.00	0	20.00
16QAM	5	≤ 8	1	23.00	0	20.00
16QAM	5	> 8	2	22.00	0	20.00

LTE Band 25						
Modulation	BW (MHz)	RB size	Full Power Mode		Reduce Power Mode	
			MPR	Average Power (dBm)	MPR	Average Power (dBm)
QPSK	20	≤ 18	0	24.00	0	20.00
QPSK	20	> 18	1	23.00	0	20.00
16QAM	20	≤ 18	1	23.00	0	20.00
16QAM	20	> 18	2	22.00	0	20.00
QPSK	15	≤ 16	0	24.00	0	20.00
QPSK	15	> 16	1	23.00	0	20.00
16QAM	15	≤ 16	1	23.00	0	20.00
16QAM	15	> 16	2	22.00	0	20.00
QPSK	10	≤ 12	0	24.00	0	20.00
QPSK	10	> 12	1	23.00	0	20.00
16QAM	10	≤ 12	1	23.00	0	20.00
16QAM	10	> 12	2	22.00	0	20.00
QPSK	5	≤ 8	0	24.00	0	20.00
QPSK	5	> 8	1	23.00	0	20.00
16QAM	5	≤ 8	1	23.00	0	20.00
16QAM	5	> 8	2	22.00	0	20.00



4.3 General LTE SAR Test and Reporting Considerations

Summarized necessary items addressed in KDB 941225 D05 v02r03																																																		
FCC ID	Q2GEM7355B																																																	
Equipment Name	Wireless Modules																																																	
Operating Frequency Range of each LTE transmission band	LTE Band 17: 706.5 MHz ~ 713.5 MHz LTE Band 13: 779.5 MHz ~ 784.5 MHz LTE Band 05: 824.7 MHz ~ 848.3 MHz LTE Band 04: 1710.7 MHz ~ 1754.3 MHz LTE Band 02: 1850.7 MHz ~ 1909.3 MHz LTE Band 25: 1850.7 MHz ~ 1914.3 MHz																																																	
Channel Bandwidth	LTE Band 17: 5MHz, 10MHz LTE Band 13: 5MHz, 10MHz LTE Band 05: 1.4MHz, 3MHz, 5MHz, 10MHz LTE Band 04: 1.4MHz, 3MHz, 5MHz, 10MHz, 15MHz, 20MHz LTE Band 02: 1.4MHz, 3MHz, 5MHz, 10MHz, 15MHz, 20MHz LTE Band 25: 1.4MHz, 3MHz, 5MHz, 10MHz, 15MHz, 20MHz																																																	
uplink modulations used	QPSK, and 16QAM																																																	
LTE Voice / Data requirements	Data only																																																	
LTE MPR permanently built-in by design	<table border="1"> <thead> <tr> <th colspan="8">Table 6.2.3-1: Maximum Power Reduction (MPR) for Power Class 3</th> </tr> <tr> <th rowspan="2">Modulation</th> <th colspan="6">Channel bandwidth / Transmission bandwidth (RB)</th> <th rowspan="2">MPR (dB)</th> </tr> <tr> <th>1.4 MHz</th> <th>3.0 MHz</th> <th>5 MHz</th> <th>10 MHz</th> <th>15 MHz</th> <th>20 MHz</th> </tr> </thead> <tbody> <tr> <td>QPSK</td> <td>> 5</td> <td>> 4</td> <td>> 8</td> <td>> 12</td> <td>> 16</td> <td>> 18</td> <td>≤ 1</td> </tr> <tr> <td>16 QAM</td> <td>≤ 5</td> <td>≤ 4</td> <td>≤ 8</td> <td>≤ 12</td> <td>≤ 16</td> <td>≤ 18</td> <td>≤ 1</td> </tr> <tr> <td>16 QAM</td> <td>> 5</td> <td>> 4</td> <td>> 8</td> <td>> 12</td> <td>> 16</td> <td>> 18</td> <td>≤ 2</td> </tr> </tbody> </table>				Table 6.2.3-1: Maximum Power Reduction (MPR) for Power Class 3								Modulation	Channel bandwidth / Transmission bandwidth (RB)						MPR (dB)	1.4 MHz	3.0 MHz	5 MHz	10 MHz	15 MHz	20 MHz	QPSK	> 5	> 4	> 8	> 12	> 16	> 18	≤ 1	16 QAM	≤ 5	≤ 4	≤ 8	≤ 12	≤ 16	≤ 18	≤ 1	16 QAM	> 5	> 4	> 8	> 12	> 16	> 18	≤ 2
Table 6.2.3-1: Maximum Power Reduction (MPR) for Power Class 3																																																		
Modulation	Channel bandwidth / Transmission bandwidth (RB)						MPR (dB)																																											
	1.4 MHz	3.0 MHz	5 MHz	10 MHz	15 MHz	20 MHz																																												
QPSK	> 5	> 4	> 8	> 12	> 16	> 18	≤ 1																																											
16 QAM	≤ 5	≤ 4	≤ 8	≤ 12	≤ 16	≤ 18	≤ 1																																											
16 QAM	> 5	> 4	> 8	> 12	> 16	> 18	≤ 2																																											
LTE A-MPR	In the base station simulator configuration, Network Setting value is set to NS_01 to disable A-MPR during SAR testing and the LTE SAR tests was transmitting on all TTI frames (Maximum TTI)																																																	
Spectrum plots for RB configuration	A properly configured base station simulator was used for the SAR and power measurement; therefore, spectrum plots for each RB allocation and offset configuration are not included in the SAR report.																																																	
Power reduction applied to satisfy SAR compliance	Yes, proximity sensor.																																																	
Transmission (H, M, L) channel numbers and frequencies in each LTE band																																																		
LTE Band 17																																																		
	Bandwidth 5 MHz		Bandwidth 10 MHz																																															
	Channel #	Freq.(MHz)	Channel #	Freq. (MHz)																																														
L	23755	706.5	23780	709																																														
M	23790	710	23790	710																																														
H	23825	713.5	23800	711																																														
LTE Band 13																																																		
	Bandwidth 5 MHz		Bandwidth 10 MHz																																															
	Channel #	Freq.(MHz)	Channel #	Freq.(MHz)																																														
L	23205	779.5																																																
M	23230	782	23230	782																																														
H	23255	784.5																																																



Transmission (H, M, L) channel numbers and frequencies in each LTE band												
LTE Band 5												
	Bandwidth 1.4 MHz		Bandwidth 3 MHz		Bandwidth 5 MHz		Bandwidth 10 MHz		Bandwidth 15 MHz		Bandwidth 20 MHz	
	Ch. #	Freq. (MHz)	Ch. #	Freq. (MHz)	Ch. #	Freq. (MHz)	Ch. #	Freq. (MHz)	Ch. #	Freq. (MHz)	Ch. #	Freq. (MHz)
L	20407	824.7	20415	825.5	20425	826.5	20450	829				
M	20525	836.5	20525	836.5	20525	836.5	20525	836.5				
H	20643	848.3	20635	847.5	20625	846.5	20600	844				
LTE Band 4												
	Bandwidth 1.4 MHz		Bandwidth 3 MHz		Bandwidth 5 MHz		Bandwidth 10 MHz		Bandwidth 15 MHz		Bandwidth 20 MHz	
	Ch. #	Freq. (MHz)	Ch. #	Freq. (MHz)	Ch. #	Freq. (MHz)	Ch. #	Freq. (MHz)	Ch. #	Freq. (MHz)	Ch. #	Freq. (MHz)
L	19957	1710.7	19965	1711.5	19975	1712.5	20000	1715	20025	1717.5	20050	1720
M	20175	1732.5	20175	1732.5	20175	1732.5	20175	1732.5	20175	1732.5	20175	1732.5
H	20393	1754.3	20385	1753.5	20375	1752.5	20350	1750	20325	1747.5	20300	1745
LTE Band 2												
	Bandwidth 1.4 MHz		Bandwidth 3 MHz		Bandwidth 5 MHz		Bandwidth 10 MHz		Bandwidth 15 MHz		Bandwidth 20 MHz	
	Ch. #	Freq. (MHz)	Ch. #	Freq. (MHz)	Ch. #	Freq. (MHz)	Ch. #	Freq. (MHz)	Ch. #	Freq. (MHz)	Ch. #	Freq. (MHz)
L	18607	1850.7	18615	1851.5	18625	1852.5	18650	1855	18675	1857.5	18700	1860
M	18900	1880	18900	1880	18900	1880	18900	1880	18900	1880	18900	1880
H	19193	1909.3	19185	1908.5	19175	1907.5	19150	1905	19125	1902.5	19100	1900
LTE Band 25												
	Bandwidth 1.4 MHz		Bandwidth 3 MHz		Bandwidth 5 MHz		Bandwidth 10 MHz		Bandwidth 15 MHz		Bandwidth 20 MHz	
	Ch. #	Freq. (MHz)	Ch. #	Freq. (MHz)	Ch. #	Freq. (MHz)	Ch. #	Freq. (MHz)	Ch. #	Freq. (MHz)	Ch. #	Freq. (MHz)
L	26047	1850.7	26055	1851.5	26065	1852.5	26090	1855	26115	1857.5	26140	1860
M	26340	1880	26340	1880	26340	1880	26340	1880	26340	1880	26340	1880
H	26683	1914.3	26675	1913.5	26665	1912.5	26640	1910	26615	1907.5	26590	1905

5. Proximity Sensor Triggering Test

Proximity sensor power reduction

Exposure Position / wireless mode	Bottom Face ⁽¹⁾	Edge 1 ⁽¹⁾	Curved surface of Edge 1 ⁽¹⁾	Edge 2	Edge 3	Edge 4
GSM850 GPRS (GMSK 1 Tx slot) - CS1	3.5 dB	3.5 dB	3.5 dB	0 dB	0 dB	0 dB
GSM850 GPRS (GMSK 2 Tx slots) - CS1	6.0 dB	6.0 dB	6.0 dB			
GSM850 EDGE (8PSK 1 Tx slot) - MCS5	0.0 dB	0.0 dB	0.0 dB			
GSM850 EDGE (8PSK 2 Tx slots) - MCS5	1.0 dB	1.0 dB	1.0 dB			
GSM850 EDGE (8PSK 3 Tx slots) - MCS5	3.0 dB	3.0 dB	3.0 dB			
GSM850 EDGE (8PSK 4 Tx slots) - MCS5	4.0 dB	4.0 dB	4.0 dB			
GSM1900 GPRS (GMSK 1 Tx slot) - CS1	1.5 dB	1.5 dB	1.5 dB			
GSM1900 GPRS (GMSK 2 Tx slots) - CS1	4.0 dB	4.0 dB	4.0 dB			
GSM1900 EDGE (8PSK 1 Tx slot) - MCS5	0.0 dB	0.0 dB	0.0 dB			
GSM1900 EDGE (8PSK 2 Tx slots) - MCS5	1.0 dB	1.0 dB	1.0 dB			
GSM1900 EDGE (8PSK 3 Tx slots) - MCS5	3.0 dB	3.0 dB	3.0 dB			
GSM1900 EDGE (8PSK 4 Tx slots) - MCS5	4.0 dB	4.0 dB	4.0 dB			
WCDMA Band V	4.0 dB	4.0 dB	4.0 dB			
WCDMA Band II	4.0 dB	4.0 dB	4.0 dB			
WCDMA Band IV	6.0 dB	6.0 dB	6.0 dB			
CDMA2000 BC10	4.0 dB	4.0 dB	4.0 dB			
CDMA2000 BC0	4.0 dB	4.0 dB	4.0 dB			
CDMA2000 BC1	5.0 dB	5.0 dB	5.0 dB			
LTE Band 13	3.0 dB	3.0 dB	3.0 dB			
LTE Band 17	1.0 dB	1.0 dB	1.0 dB			
LTE Band 5	4.0 dB	4.0 dB	4.0 dB			
LTE Band 4	6.0 dB	6.0 dB	6.0 dB			
LTE Band 2	4.0 dB	4.0 dB	4.0 dB			
LTE Band 25	4.0 dB	4.0 dB	4.0 dB			

Remark:

- ⁽¹⁾: Reduced maximum limit applied by activation of proximity sensor.
- Power reduction is not applicable for WLAN and Bluetooth.
- Tests were performed in accordance with KDB 616217 D04 section 6.1, 6.2, 6.3, 6.4 and 6.5 and compliant results are shown and described in exhibit "P-Sensor operational description"
- For verification of compliance of power reduction scheme, additional SAR testing with EUT transmitting at full RF power at a conservative trigger distance was performed:
 - Bottom Face: [13 mm](#)
 - Edge1: [15 mm](#)
 - Curved surface of Edge 1: [15 mm](#)

Power Measurement during Sensor Trigger distance testing

Band/Mode	Ch #	Measured power reduction (dBm)		Reduction Levels
		w/o power back-off	w/ power back-off	(dB)
GSM850 GPRS (GMSK 2 Tx slot)	189	31.96	26.98	4.98
GSM1900 GPRS (GMSK 2 Tx slot)	810	29.18	25.96	3.22
WCDMA Band V	4182	22.48	19.71	2.77
WCDMA Band IV	1312	22.41	16.55	5.86
WCDMA Band II	9538	22.62	18.57	4.05
CDMA BC10	580	23.54	19.78	3.76
CDMA BC0	384	23.55	19.74	3.81
CDMA BC1	25	23.58	18.79	4.79
LTE Band 17	23790	22.62	21.60	1.02
LTE Band 13	23230	22.83	20.45	2.38
LTE Band 5	20525	22.81	18.71	4.10
LTE Band 4	20300	22.98	17.63	5.35
LTE Band 2	18700	23.12	18.99	4.13
LTE Band 25	26340	23.09	18.91	4.18

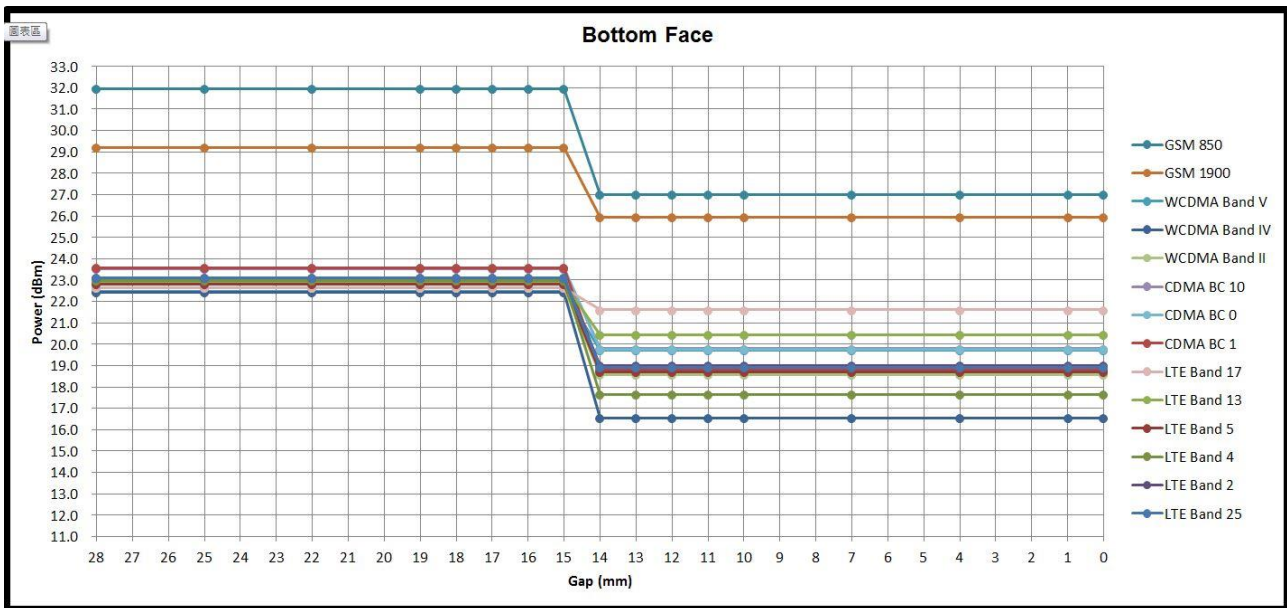

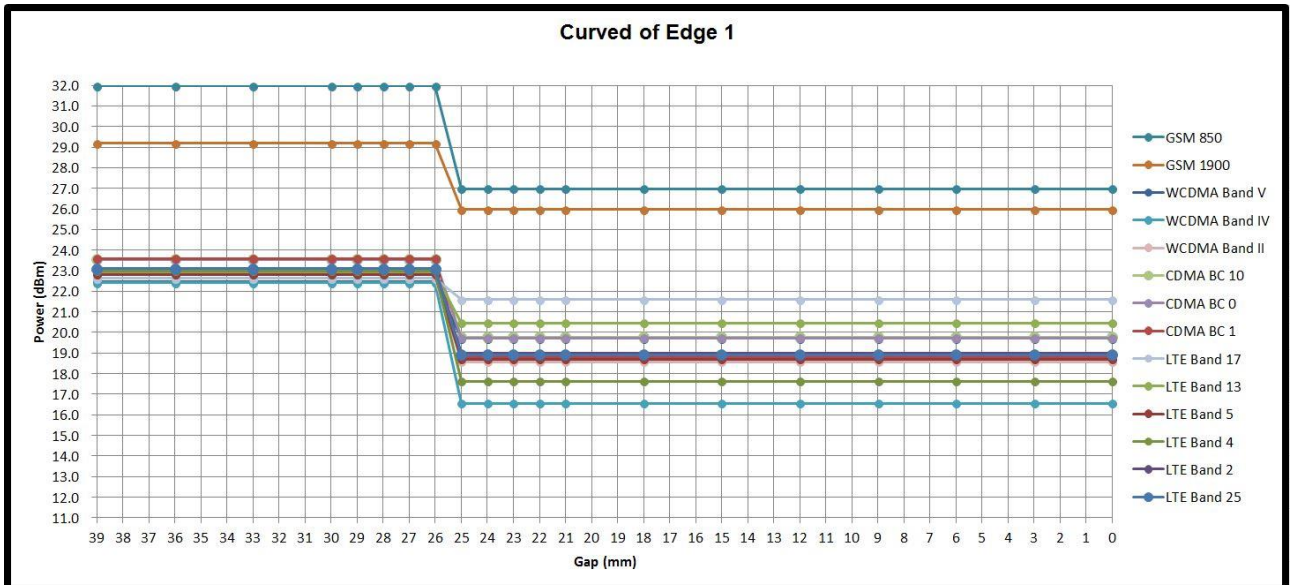
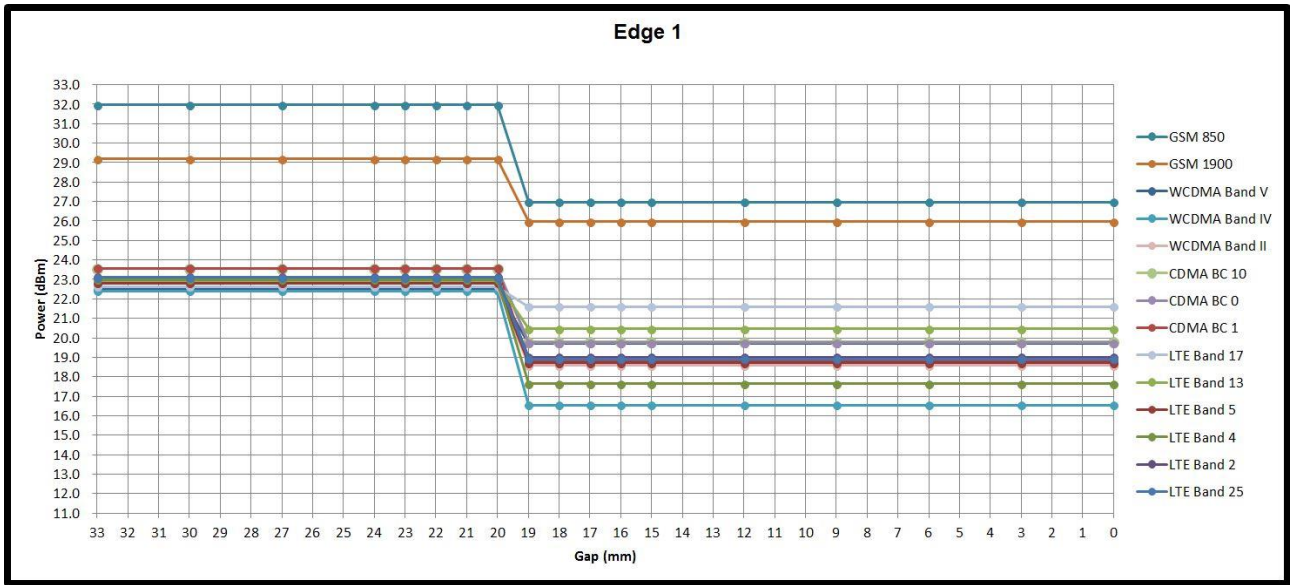

6. RF Exposure Limits

6.1 Uncontrolled Environment

Uncontrolled Environments are defined as locations where there is the exposure of individuals who have no knowledge or control of their exposure. The general population/uncontrolled exposure limits are applicable to situations in which the general public may be exposed or in which persons who are exposed as a consequence of their employment may not be made fully aware of the potential for exposure or cannot exercise control over their exposure. Members of the general public would come under this category when exposure is not employment-related; for example, in the case of a wireless transmitter that exposes persons in its vicinity.

6.2 Controlled Environment

Controlled Environments are defined as locations where there is exposure that may be incurred by persons who are aware of the potential for exposure, (i.e. as a result of employment or occupation). In general, occupational/controlled exposure limits are applicable to situations in which persons are exposed as a consequence of their employment, who have been made fully aware of the potential for exposure and can exercise control over their exposure. The exposure category is also applicable when the exposure is of a transient nature due to incidental passage through a location where the exposure levels may be higher than the general population/uncontrolled limits, but the exposed person is fully aware of the potential for exposure and can exercise control over his or her exposure by leaving the area or by some other appropriate means.

Limits for Occupational/Controlled Exposure (W/kg)

Whole-Body	Partial-Body	Hands, Wrists, Feet and Ankles
0.4	8.0	20.0

Limits for General Population/Uncontrolled Exposure (W/kg)

Whole-Body	Partial-Body	Hands, Wrists, Feet and Ankles
0.08	1.6	4.0

1. Whole-Body SAR is averaged over the entire body, partial-body SAR is averaged over any 1gram of tissue defined as a tissue volume in the shape of a cube. SAR for hands, wrists, feet and ankles is averaged over any 10 grams of tissue defined as a tissue volume in the shape of a cube.

7. Specific Absorption Rate (SAR)

7.1 Introduction

SAR is related to the rate at which energy is absorbed per unit mass in an object exposed to a radio field. The SAR distribution in a biological body is complicated and is usually carried out by experimental techniques or numerical modeling. The standard recommends limits for two tiers of groups, occupational/controlled and general population/uncontrolled, based on a person's awareness and ability to exercise control over his or her exposure. In general, occupational/controlled exposure limits are higher than the limits for general population/uncontrolled.

7.2 SAR Definition

The SAR definition is the time derivative (rate) of the incremental energy (dW) absorbed by (dissipated in) an incremental mass (dm) contained in a volume element (dv) of a given density (ρ). The equation description is as below:

$$\text{SAR} = \frac{d}{dt} \left(\frac{dW}{dm} \right) = \frac{d}{dt} \left(\frac{dW}{\rho dv} \right)$$

SAR is expressed in units of Watts per kilogram (W/kg)

$$\text{SAR} = \frac{\sigma |E|^2}{\rho}$$

Where: σ is the conductivity of the tissue, ρ is the mass density of the tissue and E is the RMS electrical field strength.

8. System Description and Setup

The DASY system used for performing compliance tests consists of the following items:

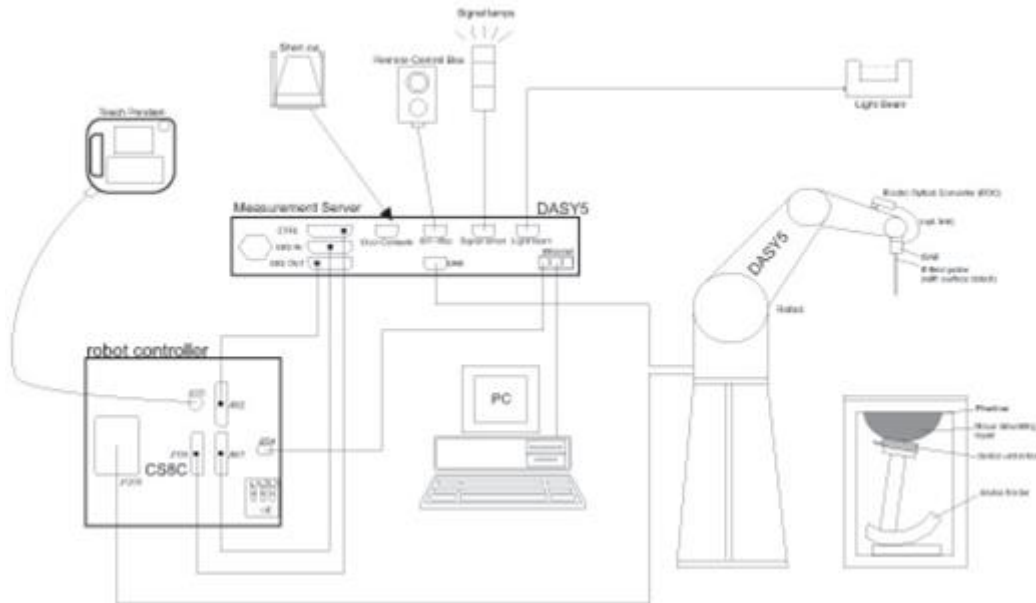

- A standard high precision 6-axis robot with controller, teach pendant and software. An arm extension for accommodating the data acquisition electronics (DAE).
- An isotropic Field probe optimized and calibrated for the targeted measurement.
- A data acquisition electronics (DAE) which performs the signal amplification, signal multiplexing, AD-conversion, offset measurements, mechanical surface detection, collision detection, etc. The unit is battery powered with standard or rechargeable batteries. The signal is optically transmitted to the EOC.
- The Electro-optical converter (EOC) performs the conversion from optical to electrical signals for the digital communication to the DAE. To use optical surface detection, a special version of the EOC is required. The EOC signal is transmitted to the measurement server.
- The function of the measurement server is to perform the time critical tasks such as signal filtering, control of the robot operation and fast movement interrupts.
- The Light Beam used is for probe alignment. This improves the (absolute) accuracy of the probe positioning.
- A computer running WinXP or Win7 and the DASY5 software.
- Remote control and teach pendant as well as additional circuitry for robot safety such as warning lamps, etc.
- The phantom, the device holder and other accessories according to the targeted measurement.



9. Measurement Procedures

The measurement procedures are as follows:

<Conducted power measurement>

- (a) For WWAN power measurement, use base station simulator to configure EUT WWAN transmission in conducted connection with RF cable, at maximum power in each supported wireless interface and frequency band.
- (b) Read the WWAN RF power level from the base station simulator.
- (c) For WLAN/BT power measurement, use engineering software to configure EUT WLAN/BT continuously transmission, at maximum RF power in each supported wireless interface and frequency band
- (d) Connect EUT RF port through RF cable to the power meter, and measure WLAN/BT output power

<SAR measurement>

- (a) Use base station simulator to configure EUT WWAN transmission in radiated connection, and engineering software to configure EUT WLAN/BT continuously transmission, at maximum RF power, in the highest power channel.
- (b) Place the EUT in the positions as Appendix D demonstrates.
- (c) Set scan area, grid size and other setting on the DASY software.
- (d) Measure SAR results for the highest power channel on each testing position.
- (e) Find out the largest SAR result on these testing positions of each band
- (f) Measure SAR results for other channels in worst SAR testing position if the reported SAR of highest power channel is larger than 0.8 W/kg

According to the test standard, the recommended procedure for assessing the peak spatial-average SAR value consists of the following steps:

- (a) Power reference measurement
- (b) Area scan
- (c) Zoom scan
- (d) Power drift measurement

9.1 Spatial Peak SAR Evaluation

The procedure for spatial peak SAR evaluation has been implemented according to the test standard. It can be conducted for 1g and 10g, as well as for user-specific masses. The DASY software includes all numerical procedures necessary to evaluate the spatial peak SAR value.

The base for the evaluation is a "cube" measurement. The measured volume must include the 1g and 10g cubes with the highest averaged SAR values. For that purpose, the center of the measured volume is aligned to the interpolated peak SAR value of a previously performed area scan.

The entire evaluation of the spatial peak values is performed within the post-processing engine (SEMCAD). The system always gives the maximum values for the 1g and 10g cubes. The algorithm to find the cube with highest averaged SAR is divided into the following stages:

- (a) Extraction of the measured data (grid and values) from the Zoom Scan
- (b) Calculation of the SAR value at every measurement point based on all stored data (A/D values and measurement parameters)
- (c) Generation of a high-resolution mesh within the measured volume
- (d) Interpolation of all measured values from the measurement grid to the high-resolution grid
- (e) Extrapolation of the entire 3-D field distribution to the phantom surface over the distance from sensor to surface
- (f) Calculation of the averaged SAR within masses of 1g and 10g

9.2 Power Reference Measurement

The Power Reference Measurement and Power Drift Measurements are for monitoring the power drift of the device under test in the batch process. The minimum distance of probe sensors to surface determines the closest measurement point to phantom surface. This distance cannot be smaller than the distance of sensor calibration points to probe tip as defined in the probe properties.

9.3 Area Scan

The area scan is used as a fast scan in two dimensions to find the area of high field values, before doing a fine measurement around the hot spot. The sophisticated interpolation routines implemented in DASY software can find the maximum found in the scanned area, within a range of the global maximum. The range (in dB0 is specified in the standards for compliance testing. For example, a 2 dB range is required in IEEE standard 1528 and IEC 62209 standards, whereby 3 dB is a requirement when compliance is assessed in accordance with the ARIB standard (Japan), if only one zoom scan follows the area scan, then only the absolute maximum will be taken as reference. For cases where multiple maximums are detected, the number of zoom scans has to be increased accordingly.

Area scan parameters extracted from FCC KDB 865664 D01v01r03 SAR measurement 100 MHz to 6 GHz.

	≤ 3 GHz	> 3 GHz
Maximum distance from closest measurement point (geometric center of probe sensors) to phantom surface	5 ± 1 mm	$\frac{1}{2} \cdot \delta \cdot \ln(2) \pm 0.5$ mm
Maximum probe angle from probe axis to phantom surface normal at the measurement location	30° ± 1°	20° ± 1°
Maximum area scan spatial resolution: $\Delta x_{Area}, \Delta y_{Area}$	≤ 2 GHz: ≤ 15 mm 2 – 3 GHz: ≤ 12 mm	3 – 4 GHz: ≤ 12 mm 4 – 6 GHz: ≤ 10 mm
	When the x or y dimension of the test device, in the measurement plane orientation, is smaller than the above, the measurement resolution must be ≤ the corresponding x or y dimension of the test device with at least one measurement point on the test device.	

9.4 Zoom Scan

Zoom scans are used assess the peak spatial SAR values within a cubic averaging volume containing 1 gram and 10 gram of simulated tissue. The zoom scan measures points (refer to table below) within a cube shoes base faces are centered on the maxima found in a preceding area scan job within the same procedure. When the measurement is done, the zoom scan evaluates the averaged SAR for 1 gram and 10 gram and displays these values next to the job's label.

Zoom scan parameters extracted from FCC KDB 865664 D01v01r03 SAR measurement 100 MHz to 6 GHz.

		≤ 3 GHz	> 3 GHz	
Maximum zoom scan spatial resolution: $\Delta x_{Zoom}, \Delta y_{Zoom}$		≤ 2 GHz: ≤ 8 mm 2 – 3 GHz: ≤ 5 mm*	3 – 4 GHz: ≤ 5 mm* 4 – 6 GHz: ≤ 4 mm*	
Maximum zoom scan spatial resolution, normal to phantom surface	uniform grid: $\Delta z_{Zoom}(n)$	≤ 5 mm	3 – 4 GHz: ≤ 4 mm 4 – 5 GHz: ≤ 3 mm 5 – 6 GHz: ≤ 2 mm	
	graded grid	$\Delta z_{Zoom}(1)$: between 1 st two points closest to phantom surface	≤ 4 mm	3 – 4 GHz: ≤ 3 mm 4 – 5 GHz: ≤ 2.5 mm 5 – 6 GHz: ≤ 2 mm
		$\Delta z_{Zoom}(n>1)$: between subsequent points	$\leq 1.5 \cdot \Delta z_{Zoom}(n-1)$	
Minimum zoom scan volume	x, y, z	≥ 30 mm	3 – 4 GHz: ≥ 28 mm 4 – 5 GHz: ≥ 25 mm 5 – 6 GHz: ≥ 22 mm	
Note: δ is the penetration depth of a plane-wave at normal incidence to the tissue medium; see draft standard IEEE P1528-2011 for details. * When zoom scan is required and the <i>reported</i> SAR from the <i>area scan based 1-g SAR estimation</i> procedures of KDB 447498 is ≤ 1.4 W/kg, ≤ 8 mm, ≤ 7 mm and ≤ 5 mm zoom scan resolution may be applied, respectively, for 2 GHz to 3 GHz, 3 GHz to 4 GHz and 4 GHz to 6 GHz.				

9.5 Volume Scan Procedures

The volume scan is used for assess overlapping SAR distributions for antennas transmitting in different frequency bands. It is equivalent to an oversized zoom scan used in standalone measurements. The measurement volume will be used to enclose all the simultaneous transmitting antennas. For antennas transmitting simultaneously in different frequency bands, the volume scan is measured separately in each frequency band. In order to sum correctly to compute the 1g aggregate SAR, the EUT remain in the same test position for all measurements and all volume scan use the same spatial resolution and grid spacing. When all volume scan were completed, the software, SEMCAD postprocessor can combine and subsequently superpose these measurement data to calculating the multiband SAR.

9.6 Power Drift Monitoring

All SAR testing is under the EUT install full charged battery and transmit maximum output power. In DASYS measurement software, the power reference measurement and power drift measurement procedures are used for monitoring the power drift of EUT during SAR test. Both these procedures measure the field at a specified reference position before and after the SAR testing. The software will calculate the field difference in dB. If the power drifts more than 5%, the SAR will be retested.



10. Test Equipment List

Manufacturer	Name of Equipment	Type/Model	Serial Number	Calibration	
				Last Cal.	Due Date
SPEAG	750MHz System Validation Kit	D750V3	1099	Nov. 19, 2014	Nov. 18, 2015
SPEAG	835MHz System Validation Kit	D835V2	4d162	Nov. 19, 2014	Nov. 18, 2015
SPEAG	1750MHz System Validation Kit	D1750V2	1068	Nov. 14, 2014	Nov. 13, 2015
SPEAG	1900MHz System Validation Kit	D1900V2	5d182	Nov. 14, 2014	Nov. 13, 2015
SPEAG	Data Acquisition Electronics	DAE4	1388	Sep. 24, 2014	Sep. 23, 2015
SPEAG	Data Acquisition Electronics	DAE4	1399	Nov. 13, 2014	Nov. 12, 2015
SPEAG	Dosimetric E-Field Probe	EX3DV4	3697	Sep. 29, 2014	Sep. 28, 2015
SPEAG	Dosimetric E-Field Probe	EX3DV4	3955	Nov. 21, 2014	Nov. 20, 2015
Wisewind	Thermometer	ETP-101	TM560	Oct. 21, 2014	Oct. 20, 2015
Wisewind	Thermometer	ETP-101	TM685	Oct. 21, 2014	Oct. 20, 2015
Anritsu	Radio Communication Analyzer	MT8820C	6201381760	May. 28, 2014	May. 27, 2015
Agilent	Wireless Communication Test Set	E5515C	MY50266977	May. 27, 2014	May. 26, 2015
SPEAG	Device Holder	N/A	N/A	NCR	NCR
R&S	Signal Generator	SMU200A	102502	Jul. 07, 2014	Jul. 06, 2015
SPEAG	Dielectric Probe Kit	DAK-3.5	1138	Nov. 18, 2014	Nov. 17, 2015
Agilent	ENA Network Analyzer	E5071C	MY46101588	May. 31, 2014	May. 30, 2015
Anritsu	Power Meter	ML2495A	1036004	Aug. 09, 2014	Aug. 08, 2015
Anritsu	Power Sensor	MA2411B	1027253	Aug. 11, 2014	Aug. 10, 2015
R&S	Spectrum Analyzer	FSP 30	101329	Jun. 14, 2014	Jun. 13, 2015
Agilent	Dual Directional Coupler	778D	50422	Note1	
Woken	Attenuator 1	WK0602-XX	N/A	Note1	
PE	Attenuator 2	PE7005-10	N/A	Note1	
PE	Attenuator 3	PE7005- 3	N/A	Note1	
AR	Power Amplifier	5S1G4M2	0328767	Note1	
Mini-Circuits	Power Amplifier	ZVE-3W	162601250	Note1	
Mini-Circuits	Power Amplifier	ZHL-42W+	13440021344	Note1	

General Note:

1. Prior to system verification and validation, the path loss from the signal generator to the system check source and the power meter, which includes the amplifier, cable, attenuator and directional coupler, was measured by the network analyzer. The reading of the power meter was offset by the path loss difference between the path to the power meter and the path to the system check source to monitor the actual power level fed to the system check source.



11. System Verification

11.1 Tissue Verification

The following tissue formulations are provided for reference only as some of the parameters have not been thoroughly verified. The composition of ingredients may be modified accordingly to achieve the desired target tissue parameters required for routine SAR evaluation.

Frequency (MHz)	Water (%)	Sugar (%)	Cellulose (%)	Salt (%)	Preventol (%)	DGBE (%)	Conductivity (σ)	Permittivity (ϵ_r)
For Head								
750	41.1	57.0	0.2	1.4	0.2	0	0.89	41.9
835	40.3	57.9	0.2	1.4	0.2	0	0.90	41.5
900	40.3	57.9	0.2	1.4	0.2	0	0.97	41.5
1800, 1900, 2000	55.2	0	0	0.3	0	44.5	1.40	40.0
2450	55.0	0	0	0	0	45.0	1.80	39.2
2600	54.8	0	0	0.1	0	45.1	1.96	39.0
For Body								
750	51.7	47.2	0	0.9	0.1	0	0.96	55.5
835	50.8	48.2	0	0.9	0.1	0	0.97	55.2
900	50.8	48.2	0	0.9	0.1	0	1.05	55.0
1800, 1900, 2000	70.2	0	0	0.4	0	29.4	1.52	53.3
2450	68.6	0	0	0	0	31.4	1.95	52.7
2600	68.1	0	0	0.1	0	31.8	2.16	52.5

Simulating Liquid for 5GHz, Manufactured by SPEAG

Ingredients	(% by weight)
Water	64~78%
Mineral oil	11~18%
Emulsifiers	9~15%
Additives and Salt	2~3%

<Tissue Dielectric Parameter Check Results>

Frequency (MHz)	Tissue Type	Liquid Temp. (°C)	Conductivity (σ)	Permittivity (ϵ_r)	Conductivity Target (σ)	Permittivity Target (ϵ_r)	Delta (σ) (%)	Delta (ϵ_r) (%)	Limit (%)	Date
750	MSL	22.4	0.973	56.585	0.96	55.50	1.35	1.95	±5	2015/2/24
835	MSL	22.6	0.963	54.498	0.97	55.20	-0.72	-1.27	±5	2015/2/20
835	MSL	22.4	0.981	55.046	0.97	55.20	1.13	-0.28	±5	2015/2/24
1750	MSL	22.3	1.518	52.095	1.49	53.40	1.88	-2.44	±5	2015/2/19
1900	MSL	22.5	1.532	53.576	1.52	53.30	0.79	0.52	±5	2015/2/18
1900	MSL	22.3	1.569	51.586	1.52	53.30	3.22	-3.22	±5	2015/2/19

11.2 System Performance Check Results

Comparing to the original SAR value provided by SPEAG, the verification data should be within its specification of 10 %. Below table shows the target SAR and measured SAR after normalized to 1W input power. The table below indicates the system performance check can meet the variation criterion and the plots can be referred to Appendix A of this report.

Date	Frequency (MHz)	Tissue Type	Input Power (mW)	Dipole S/N	Probe S/N	DAE S/N	Measured 1g SAR (W/kg)	Targeted 1g SAR (W/kg)	Normalized 1g SAR (W/kg)	Deviation (%)
2015/2/24	750	MSL	250	D750V3-1099	EX3DV4 - SN3697	DAE4 Sn1388	2.07	8.56	8.28	-3.27
2015/2/20	835	MSL	250	D835V2-4d162	EX3DV4 - SN3955	DAE4 Sn1399	2.26	9.56	9.04	-5.44
2015/2/24	835	MSL	250	D835V2-4d162	EX3DV4 - SN3697	DAE4 Sn1388	2.48	9.56	9.92	3.77
2015/2/19	1750	MSL	250	D1750V2-1068	EX3DV4 - SN3955	DAE4 Sn1399	8.77	38.00	35.08	-7.68
2015/2/18	1900	MSL	250	D1900V2-5d182	EX3DV4 - SN3955	DAE4 Sn1399	9.71	40.00	38.84	-2.90
2015/2/19	1900	MSL	250	D1900V2-5d182	EX3DV4 - SN3955	DAE4 Sn1399	9.50	40.00	38.00	-5.00

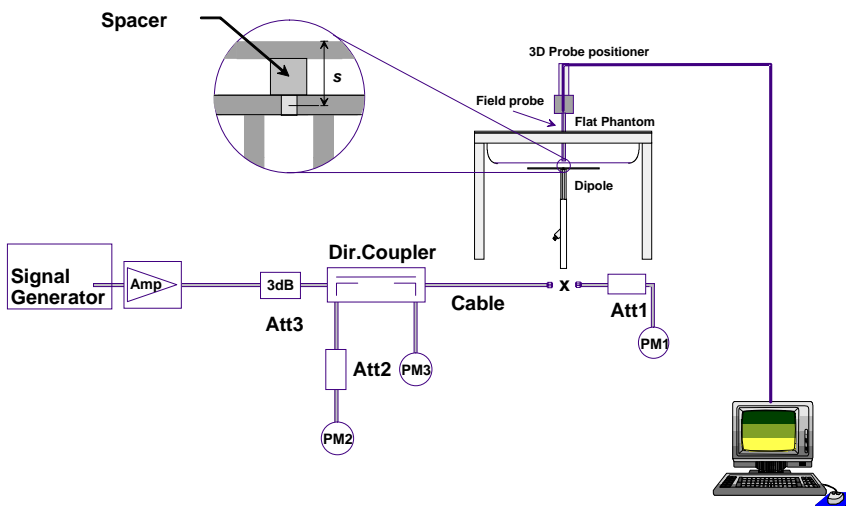

Fig 8.3.1 System Performance Check Setup



Fig 8.3.2 Setup Photo

12. RF Exposure Positions

12.1 SAR Testing for Tablet

This device can be used also in full sized tablet exposure conditions, due to its size. Per FCC KDB 616217, the back surface and edges of the tablet should be tested for SAR compliance with the tablet touching the phantom. The SAR exclusion threshold in KDB 447498 D01v05r02 can be applied to determine SAR test exclusion for adjacent edge configurations. The closest distance from the antenna to an adjacent tablet edge is used to determine if SAR testing is required for the adjacent edges, with the adjacent edge positioned against the phantom and the edge containing the antenna positioned perpendicular to the phantom.



13. Conducted RF Output Power (Unit: dBm)

<GSM Conducted Power>

General Note:

- Per KDB 447498 D01v05r02, the maximum output power channel is used for SAR testing and for further SAR test reduction.
- Per KDB 941225 D01v03, for Body SAR test reduction for GPRS and EDGE modes is determined by the source-based time-averaged output power including tune-up tolerance, for modes with the same specified maximum output power and tolerance, the higher number time-slot configuration should be tested, therefore, the GPRS 2Tx slots modes was selected when EUT operating without power back-off, the GPRS 2Tx slots modes was selected when EUT operating with power back-off, according to the highest source-based time-averaged output power.

Full Power Mode (Proximity Sensor Inactive)

Band GSM850	Burst Average Power (dBm)			Tune-up Limit (dBm)	Frame-Average Power (dBm)			Tune-up Limit (dBm)
	TX Channel	128	189		251	128	189	
Frequency (MHz)	824.2	836.4	848.8		824.2	836.4	848.8	
GPRS (GMSK, 1 Tx slot)	32.17	32.19	32.00	33.50	23.17	23.19	23.00	24.50
GPRS (GMSK, 2 Tx slots)	31.93	31.96	31.89	33.00	25.93	25.96	25.89	27.00
EDGE (8PSK, 1 Tx slot)	26.44	26.39	26.37	28.00	17.44	17.39	17.37	19.00
EDGE (8PSK, 2 Tx slots)	26.30	26.27	26.34	27.00	20.30	20.27	20.34	21.00
EDGE (8PSK, 3 Tx slots)	26.07	26.02	26.19	27.00	21.81	21.76	21.93	22.74
EDGE (8PSK, 4 Tx slots)	25.80	25.86	25.94	27.00	22.80	22.86	22.94	24.00

Band GSM1900	Burst Average Power (dBm)			Tune-up Limit (dBm)	Frame-Average Power (dBm)			Tune-up Limit (dBm)
	TX Channel	512	661		810	512	661	
Frequency (MHz)	1850.2	1880	1909.8		1850.2	1880	1909.8	
GPRS (GMSK, 1 Tx slot)	29.21	29.08	29.23	30.50	20.21	20.08	20.23	21.50
GPRS (GMSK, 2 Tx slots)	29.17	29.00	29.18	30.00	23.17	23.00	23.18	24.00
EDGE (8PSK, 1 Tx slot)	25.42	25.38	25.41	27.00	16.42	16.38	16.41	18.00
EDGE (8PSK, 2 Tx slots)	25.39	25.37	25.38	26.00	19.39	19.37	19.38	20.00
EDGE (8PSK, 3 Tx slots)	25.11	25.10	25.07	26.00	20.85	20.84	20.81	21.74
EDGE (8PSK, 4 Tx slots)	24.01	24.03	24.06	26.00	21.01	21.03	21.06	23.00

Reduced Power Mode (Proximity Sensor active)

Band GSM850	Burst Average Power (dBm)			Tune-up Limit (dBm)	Frame-Average Power (dBm)			Tune-up Limit (dBm)
	TX Channel	128	189		251	128	189	
Frequency (MHz)	824.2	836.4	848.8		824.2	836.4	848.8	
GPRS (GMSK, 1 Tx slot)	29.22	29.57	29.50	30.00	20.22	20.57	20.50	21.00
GPRS (GMSK, 2 Tx slots)	26.91	26.98	26.94	27.00	20.91	20.98	20.94	21.00
EDGE (8PSK, 1 Tx slot)	26.44	26.39	26.37	28.00	17.44	17.39	17.37	19.00
EDGE (8PSK, 2 Tx slots)	24.22	24.15	24.16	26.00	18.22	18.15	18.16	20.00
EDGE (8PSK, 3 Tx slots)	23.90	23.88	23.95	24.00	19.64	19.62	19.69	19.74
EDGE (8PSK, 4 Tx slots)	22.66	22.70	22.77	23.00	19.66	19.70	19.77	20.00

Band GSM1900	Burst Average Power (dBm)			Tune-up Limit (dBm)	Frame-Average Power (dBm)			Tune-up Limit (dBm)
	TX Channel	512	661		810	512	661	
Frequency (MHz)	1850.2	1880	1909.8		1850.2	1880	1909.8	
GPRS (GMSK, 1 Tx slot)	28.12	28.08	28.31	29.00	19.12	19.08	19.31	20.00
GPRS (GMSK, 2 Tx slots)	25.85	25.83	25.96	26.00	19.85	19.83	19.96	20.00
EDGE (8PSK, 1 Tx slot)	25.42	25.38	25.41	27.00	16.42	16.38	16.41	18.00
EDGE (8PSK, 2 Tx slots)	24.35	24.34	24.43	25.00	18.35	18.34	18.43	19.00
EDGE (8PSK, 3 Tx slots)	22.93	22.95	22.98	23.00	18.67	18.69	18.72	18.74
EDGE (8PSK, 4 Tx slots)	21.86	21.83	21.88	22.00	18.86	18.83	18.88	19.00

<WCDMA Conducted Power>

1. The following tests were conducted according to the test requirements outlines in 3GPP TS 34.121 specification.
2. The procedures in KDB 941225 D01 are applied for 3GPP Rel. 6 HSPA to configure the device in the required sub-test mode(s) to determine SAR test exclusion.
3. For DC-HSDPA, the device was configured according to the H-Set 12, Fixed Reference Channel (FRC) configuration in Table C.8.1.12 of 3GPP TS 34.121-1, with the primary and the secondary serving HS-DSCH Cell enabled during the power measurement.

A summary of these settings are illustrated below:

HSDPA Setup Configuration:

- a. The EUT was connected to Base Station Agilent E5515C referred to the Setup Configuration.
- b. The RF path losses were compensated into the measurements.
- c. A call was established between EUT and Base Station with following setting:
 - i. Set Gain Factors (β_c and β_d) and parameters were set according to each
 - ii. Specific sub-test in the following table, C10.1.4, quoted from the TS 34.121
 - iii. Set RMC 12.2Kbps + HSDPA mode.
 - iv. Set Cell Power = -86 dBm
 - v. Set HS-DSCH Configuration Type to FRC (H-set 1, QPSK)
 - vi. Select HSDPA Uplink Parameters
 - vii. Set Delta ACK, Delta NACK and Delta CQI = 8
 - viii. Set Ack-Nack Repetition Factor to 3
 - ix. Set CQI Feedback Cycle (k) to 4 ms
 - x. Set CQI Repetition Factor to 2
 - xi. Power Ctrl Mode = All Up bits
- d. The transmitted maximum output power was recorded.

Table C.10.1.4: β values for transmitter characteristics tests with HS-DPCCH

Sub-test	β_c	β_d	β_d (SF)	β_c/β_d	β_{HS} (Note 1, Note 2)	CM (dB) (Note 3)	MPR (dB) (Note 3)
1	2/15	15/15	64	2/15	4/15	0.0	0.0
2	12/15 (Note 4)	15/15 (Note 4)	64	12/15 (Note 4)	24/15	1.0	0.0
3	15/15	8/15	64	15/8	30/15	1.5	0.5
4	15/15	4/15	64	15/4	30/15	1.5	0.5

Note 1: $\Delta_{ACK}, \Delta_{NACK}$ and $\Delta_{CQI} = 30/15$ with $\beta_{HS} = 30/15 * \beta_c$.

Note 2: For the HS-DPCCH power mask requirement test in clause 5.2C, 5.7A, and the Error Vector Magnitude (EVM) with HS-DPCCH test in clause 5.13.1A, and HSDPA EVM with phase discontinuity in clause 5.13.1AA, Δ_{ACK} and $\Delta_{NACK} = 30/15$ with $\beta_{HS} = 30/15 * \beta_c$, and $\Delta_{CQI} = 24/15$ with $\beta_{HS} = 24/15 * \beta_c$.

Note 3: CM = 1 for $\beta_c/\beta_d = 12/15, \beta_{HS}/\beta_c = 24/15$. For all other combinations of DPCCH, DPDCCH and HS-DPCCH the MPR is based on the relative CM difference. This is applicable for only UEs that support HSDPA in release 6 and later releases.

Note 4: For subtest 2 the β_c/β_d ratio of 12/15 for the TFC during the measurement period (TF1, TF0) is achieved by setting the signalled gain factors for the reference TFC (TF1, TF1) to $\beta_c = 11/15$ and $\beta_d = 15/15$.

Setup Configuration

HSUPA Setup Configuration:

- a. The EUT was connected to Base Station Agilent E5515C referred to the Setup Configuration.
- b. The RF path losses were compensated into the measurements.
- c. A call was established between EUT and Base Station with following setting * :
 - i. Call Configs = 5.2B, 5.9B, 5.10B, and 5.13.2B with QPSK
 - ii. Set the Gain Factors (β_c and β_d) and parameters (AG Index) were set according to each specific sub-test in the following table, C11.1.3, quoted from the TS 34.121
 - iii. Set Cell Power = -86 dBm
 - iv. Set Channel Type = 12.2k + HSPA
 - v. Set UE Target Power
 - vi. Power Ctrl Mode= Alternating bits
 - vii. Set and observe the E-TFCl
 - viii. Confirm that E-TFCl is equal to the target E-TFCl of 75 for sub-test 1, and other subtest's E-TFCl
- d. The transmitted maximum output power was recorded.

Table C.11.1.3: β values for transmitter characteristics tests with HS-DPCCH and E-DCH

Sub-test	β_c	β_d	β_d (SF)	β_c/β_d	β_{HS} (Note 1)	β_{ec}	β_{ed} (Note 5) (Note 6)	β_{ed} (SF)	β_{ed} (Codes)	CM (dB) (Note 2)	MPR (dB) (Note 2)	AG Index (Note 6)	E-TFCl
1	11/15 (Note 3)	15/15 (Note 3)	64	11/15 (Note 3)	22/15	209/225	1309/225	4	1	1.0	0.0	20	75
2	6/15	15/15	64	6/15	12/15	12/15	94/75	4	1	3.0	2.0	12	67
3	15/15	9/15	64	15/9	30/15	30/15	β_{ed1} : 47/15 β_{ed2} : 47/15	4 4	2	2.0	1.0	15	92
4	2/15	15/15	64	2/15	4/15	2/15	56/75	4	1	3.0	2.0	17	71
5	15/15 (Note 4)	15/15 (Note 4)	64	15/15 (Note 4)	30/15	24/15	134/15	4	1	1.0	0.0	21	81

Note 1: $\Delta_{ACK}, \Delta_{NACK}$ and $\Delta_{CQI} = 30/15$ with $\beta_{hs} = 30/15 * \beta_c$.

Note 2: CM = 1 for $\beta_c/\beta_d = 12/15, \beta_{hs}/\beta_c = 24/15$. For all other combinations of DPDCH, DPCCH, HS-DPCCH, E-DPDCH and E-DPCCH the MPR is based on the relative CM difference.

Note 3: For subtest 1 the β_c/β_d ratio of 11/15 for the TFC during the measurement period (TF1, TF0) is achieved by setting the signalled gain factors for the reference TFC (TF1, TF1) to $\beta_c = 10/15$ and $\beta_d = 15/15$.

Note 4: For subtest 5 the β_c/β_d ratio of 15/15 for the TFC during the measurement period (TF1, TF0) is achieved by setting the signalled gain factors for the reference TFC (TF1, TF1) to $\beta_c = 14/15$ and $\beta_d = 15/15$.

Note 5: In case of testing by UE using E-DPDCH Physical Layer category 1, Sub-test 3 is omitted according to TS25.306 Table 5.1g.

Note 6: β_{ed} can not be set directly, it is set by Absolute Grant Value.

Setup Configuration

DC-HSDPA 3GPP release 8 Setup Configuration:

- a. The EUT was connected to Base Station Agilent E5515C referred to the Setup Configuration below
- b. The RF path losses were compensated into the measurements.
- c. A call was established between EUT and Base Station with following setting:
 - i. Set RMC 12.2Kbps + HSDPA mode.
 - ii. Set Cell Power = -25 dBm
 - iii. Set HS-DSCH Configuration Type to FRC (H-set 12, QPSK)
 - iv. Select HSDPA Uplink Parameters
 - v. Set Gain Factors (β_c and β_d) and parameters were set according to each Specific sub-test in the following table, C10.1.4, quoted from the TS 34.121
 - a). Subtest 1: $\beta_c/\beta_d=2/15$
 - b). Subtest 2: $\beta_c/\beta_d=12/15$
 - c). Subtest 3: $\beta_c/\beta_d=15/8$
 - d). Subtest 4: $\beta_c/\beta_d=15/4$
 - vi. Set Delta ACK, Delta NACK and Delta CQI = 8
 - vii. Set Ack-Nack Repetition Factor to 3
 - viii. Set CQI Feedback Cycle (k) to 4 ms
 - ix. Set CQI Repetition Factor to 2
 - x. Power Ctrl Mode = All Up bits
- d. The transmitted maximum output power was recorded.

The following tests were conducted according to the test requirements outlines in 3GPP TS 34.121 specification. A summary of these settings are illustrated below:

C.8.1.12 Fixed Reference Channel Definition H-Set 12

Table C.8.1.12: Fixed Reference Channel H-Set 12

Parameter	Unit	Value
Nominal Avg. Inf. Bit Rate	kbps	60
Inter-TTI Distance	TTI's	1
Number of HARQ Processes	Processes	6
Information Bit Payload (N_{INF})	Bits	120
Number Code Blocks	Blocks	1
Binary Channel Bits Per TTI	Bits	960
Total Available SML's in UE	SML's	19200
Number of SML's per HARQ Proc.	SML's	3200
Coding Rate		0.15
Number of Physical Channel Codes	Codes	1
Modulation		QPSK
Note 1: The RMC is intended to be used for DC-HSDPA mode and both cells shall transmit with identical parameters as listed in the table. Note 2: Maximum number of transmission is limited to 1, i.e., retransmission is not allowed. The redundancy and constellation version 0 shall be used.		

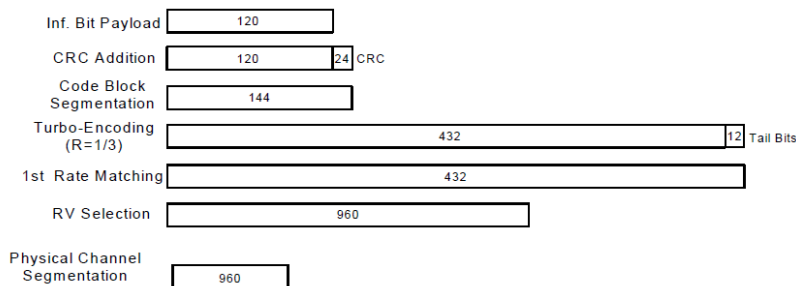

Figure C.8.19: Coding rate for Fixed reference Channel H-Set 12 (QPSK)

Setup Configuration



<WCDMA Conducted Power>

General Note:

- Per KDB 941225 D01v03, RMC 12.2kbps setting is used to evaluate SAR. If the maximum output power and tune-up tolerance specified for production units in HSDPA / HSUPA / DC-HSDPA is $\leq \frac{1}{4}$ dB higher than RMC 12.2Kbps or when the highest reported SAR of the RMC12.2Kbps is scaled by the ratio of specified maximum output power and tune-up tolerance of HSDPA / HSUPA / DC-HSDPA to RMC12.2Kbps and the adjusted SAR is ≤ 1.2 W/kg, SAR measurement is not required for HSDPA / HSUPA / DC-HSDPA.

Full Power Mode (Proximity Sensor Inactive)

Band			WCDMA V			WCDMA II			WCDMA IV		
TX Channel			4132	4182	4233	9262	9400	9538	1312	1413	1513
Frequency (MHz)			826.4	836.4	846.6	1852.4	1880	1907.6	1712.4	1732.6	1752.6
MPR (dB)	3GPP Rel 99	RMC 12.2Kbps	22.29	22.48	22.32	22.42	22.34	22.62	22.41	22.24	22.38
0	3GPP Rel 6	HSDPA Subtest-1	22.06	22.12	22.05	22.08	22.05	22.17	22.08	22.02	22.04
0	3GPP Rel 6	HSDPA Subtest-2	22.04	22.09	22.02	22.06	22.04	22.15	22.03	22.04	22.06
0.5	3GPP Rel 6	HSDPA Subtest-3	21.78	21.83	21.52	21.58	21.54	21.69	21.63	21.71	21.65
0.5	3GPP Rel 6	HSDPA Subtest-4	21.76	21.87	21.53	21.57	21.55	21.63	21.67	21.66	21.61
0	3GPP Rel 8	DC-HSDPA Subtest-1	22.05	22.11	22.04	22.04	22.03	22.15	22.07	22.01	22.04
0	3GPP Rel 8	DC-HSDPA Subtest-2	22.04	22.07	22.01	22.04	22.01	22.13	22.06	22.05	22.04
0.5	3GPP Rel 8	DC-HSDPA Subtest-3	21.77	21.82	21.51	21.56	21.54	21.67	21.72	21.81	21.84
0.5	3GPP Rel 8	DC-HSDPA Subtest-4	21.75	21.86	21.50	21.55	21.54	21.62	21.71	21.76	21.80
0	3GPP Rel 6	HSUPA Subtest-1	22.04	22.09	22.00	22.11	22.05	22.06	22.03	22.09	22.10
2	3GPP Rel 6	HSUPA Subtest-2	20.16	20.34	20.02	20.35	20.34	20.65	20.06	20.33	20.30
1	3GPP Rel 6	HSUPA Subtest-3	21.17	21.27	21.09	21.03	21.03	21.08	21.18	21.11	21.28
2	3GPP Rel 6	HSUPA Subtest-4	20.18	20.34	20.08	20.37	20.41	20.68	20.12	20.38	20.33
0	3GPP Rel 6	HSUPA Subtest-5	22.03	22.14	22.09	22.10	22.07	22.15	22.07	22.08	22.10

Reduced Power Mode (Proximity Sensor active)

Band			WCDMA V			WCDMA II			WCDMA IV		
TX Channel			4132	4182	4233	9262	9400	9538	1312	1413	1513
Frequency (MHz)			826.4	836.4	846.6	1852.4	1880	1907.6	1712.4	1732.6	1752.6
MPR (dB)	3GPP Rel 99	RMC 12.2Kbps	19.67	19.71	19.57	18.23	18.40	18.57	16.55	16.49	16.50
0	3GPP Rel 6	HSDPA Subtest-1	19.16	19.24	19.04	18.06	18.04	18.15	16.07	16.02	16.10
0	3GPP Rel 6	HSDPA Subtest-2	19.11	19.25	19.07	18.04	18.05	18.14	16.04	16.04	16.07
0.5	3GPP Rel 6	HSDPA Subtest-3	18.67	18.80	18.49	17.52	17.56	17.61	15.51	15.55	15.67
0.5	3GPP Rel 6	HSDPA Subtest-4	18.67	18.74	18.48	17.54	17.55	17.63	15.52	15.57	15.62
0	3GPP Rel 8	DC-HSDPA Subtest-1	19.14	19.22	19.01	18.04	18.06	18.17	16.05	16.01	16.09
0	3GPP Rel 8	DC-HSDPA Subtest-2	19.13	19.23	19.02	18.01	18.07	18.15	16.04	16.02	16.01
0.5	3GPP Rel 8	DC-HSDPA Subtest-3	18.65	18.80	18.52	17.55	17.54	17.62	15.51	15.54	15.57
0.5	3GPP Rel 8	DC-HSDPA Subtest-4	18.64	18.76	18.50	17.52	17.55	17.62	15.50	15.56	15.58
0	3GPP Rel 6	HSUPA Subtest-1	18.54	18.61	18.47	18.05	18.03	18.11	16.05	16.00	16.08
2	3GPP Rel 6	HSUPA Subtest-2	17.24	17.69	17.21	16.31	16.28	16.32	14.05	14.03	14.11
1	3GPP Rel 6	HSUPA Subtest-3	18.36	18.44	18.29	17.12	17.06	17.34	15.08	15.07	15.13
2	3GPP Rel 6	HSUPA Subtest-4	17.69	17.89	17.67	16.37	16.31	16.66	14.14	14.02	14.22
0	3GPP Rel 6	HSUPA Subtest-5	19.18	19.24	19.01	18.02	18.01	18.06	16.03	16.01	16.05



<CDMA2000 Conducted Power>

General Note:

- Per KDB 941225 D01v03, when in Body SAR testing, the EUT is treated as data device and SAR is tested with Ev-Do Rev 0 (RTAP 153.6kbps) as the primary mode.

Full Power Mode (Proximity Sensor Inactive)

Band	CDMA2000 BC10			CDMA2000 BC0			CDMA2000 BC1		
TX Channel	476	580	684	1013	384	777	25	600	1175
Frequency (MHz)	817.9	820.5	823.1	824.7	836.52	848.31	1851.25	1880	1908.75
1xRTT RC1 SO55	23.49	23.48	23.39	23.38	23.49	23.11	23.50	23.48	23.43
1xRTT RC3 SO55	23.50	23.53	23.43	23.38	23.53	23.08	23.56	23.50	23.53
1xEVDO RTAP 153.6Kbps	23.45	23.54	23.40	23.37	23.55	23.02	23.58	23.50	23.49
1xEVDO RETAP 4096Bits	23.44	23.49	23.38	23.36	23.48	23.01	23.51	23.48	23.47

Reduced Power Mode (Proximity Sensor active)

Band	CDMA2000 BC10			CDMA2000 BC0			CDMA2000 BC1		
TX Channel	476	580	684	1013	384	777	25	600	1175
Frequency (MHz)	817.9	820.5	823.1	824.7	836.52	848.31	1851.25	1880	1908.75
1xRTT RC1 SO55	19.67	19.70	19.57	19.52	19.63	19.42	18.52	18.51	18.48
1xRTT RC3 SO55	19.68	19.75	19.62	19.59	19.70	19.41	18.73	18.61	18.59
1xEVDO RTAP 153.6Kbps	19.70	19.78	19.50	19.58	19.74	19.48	18.79	18.63	18.68
1xEVDO RETAP 4096Bits	19.71	19.74	19.58	19.59	19.71	19.37	18.78	18.58	18.61



<LTE Conducted Power>

General Note:

1. Anritsu MT8820C base station simulator was used to setup the connection with EUT; the frequency band, channel bandwidth, RB allocation configuration, modulation type are set in the base station simulator to configure EUT transmitting at maximum power and at different configurations which are requested to be reported to FCC, for conducted power measurement and SAR testing.
2. Per KDB 941225 D05v02r03, when a properly configured base station simulator is used for the SAR and power measurements, spectrum plots for each RB allocation and offset configuration is not required.
3. Per KDB 941225 D05v02r03, start with the largest channel bandwidth and measure SAR for QPSK with 1 RB allocation, using the RB offset and required test channel combination with the highest maximum output power for RB offsets at the upper edge, middle and lower edge of each required test channel.
4. Per KDB 941225 D05v02r03, 50% RB allocation for QPSK SAR testing follows 1RB QPSK allocation procedure.
5. Per KDB 941225 D05v02r03, For QPSK with 100% RB allocation, SAR is not required when the highest maximum output power for 100 % RB allocation is less than the highest maximum output power in 50% and 1 RB allocations and the highest reported SAR for 1 RB and 50% RB allocation are ≤ 0.8 W/kg. Otherwise, SAR is measured for the highest output power channel; and if the reported SAR is > 1.45 W/kg, the remaining required test channels must also be tested.
6. Per KDB 941225 D05v02r03, 16QAM output power for each RB allocation configuration is $>$ not $\frac{1}{2}$ dB higher than the same configuration in QPSK and the reported SAR for the QPSK configuration is ≤ 1.45 W/kg; Per KDB 941225 D05v02r03, 16QAM SAR testing is not required.
7. Per KDB 941225 D05v02r03, Smaller bandwidth output power for each RB allocation configuration is $>$ not $\frac{1}{2}$ dB higher than the same configuration in the largest supported bandwidth, and the reported SAR for the largest supported bandwidth is ≤ 1.45 W/kg; Per KDB 941225 D05v02r03, smaller bandwidth SAR testing is not required.



Full Power Mode (Proximity Sensor Inactive)

<LTE Band 17>

BW [MHz]	Modulation	RB Size	RB Offset	Power Low Ch. / Freq.	Power Middle Ch. / Freq.	Power High Ch. / Freq.	Tune up Limit (dBm)	MPR (dB)
Channel				23780	23790	23800		
Frequency (MHz)				709	710	711		
10	QPSK	1	0	22.45	22.62	22.46	24	0
10	QPSK	1	24	22.43	22.61	22.43		
10	QPSK	1	49	22.17	22.01	22.00		
10	QPSK	25	0	21.55	21.72	21.53	23	1
10	QPSK	25	12	21.53	21.70	21.52		
10	QPSK	25	24	21.51	21.36	21.36		
10	QPSK	50	0	21.39	21.56	21.27	23	1
10	16QAM	1	0	21.48	21.63	21.48		
10	16QAM	1	24	21.47	21.61	21.47		
10	16QAM	1	49	21.32	21.08	21.05	22	2
10	16QAM	25	0	20.38	20.74	20.52		
10	16QAM	25	12	20.58	20.76	20.61		
10	16QAM	25	24	20.58	20.41	20.40	22	2
10	16QAM	50	0	20.43	20.57	20.37		
Channel				23755	23790	23825		
Frequency (MHz)				706.5	710	713.5		
5	QPSK	1	0	22.49	22.60	22.58	24	0
5	QPSK	1	12	22.43	22.42	22.57		
5	QPSK	1	24	22.40	22.09	22.40		
5	QPSK	12	0	21.41	21.56	21.69	23	1
5	QPSK	12	6	21.62	21.56	21.70		
5	QPSK	12	11	21.67	21.41	21.60		
5	QPSK	25	0	21.46	21.34	21.65	23	1
5	16QAM	1	0	21.53	21.54	21.56		
5	16QAM	1	12	21.45	21.52	21.48		
5	16QAM	1	24	21.51	21.14	21.44	22	2
5	16QAM	12	0	20.45	20.63	20.77		
5	16QAM	12	6	20.60	20.57	20.82		
5	16QAM	12	11	20.65	20.48	20.68	22	2
5	16QAM	25	0	20.43	20.40	20.65		



<LTE Band 13>

BW [MHz]	Modulation	RB Size	RB Offset	Power Low Ch. / Freq.	Power Middle Ch. / Freq.	Power High Ch. / Freq.	Tune up Limit (dBm)	MPR (dB)
Channel					23230			
Frequency (MHz)					782			
10	QPSK	1	0		22.83		24	0
10	QPSK	1	24		22.74			
10	QPSK	1	49		22.75			
10	QPSK	25	0		21.80		23	1
10	QPSK	25	12		21.72			
10	QPSK	25	24		21.76			
10	QPSK	50	0		21.63		23	1
10	16QAM	1	0		21.61			
10	16QAM	1	24		21.99			
10	16QAM	1	49		21.81		22	2
10	16QAM	25	0		20.60			
10	16QAM	25	12		20.77			
10	16QAM	25	24		20.69		22	2
10	16QAM	50	0		20.64			
Channel				23205	23230	23255		
Frequency (MHz)				779.5	782	784.5		
5	QPSK	1	0	22.23	22.23	22.20	24	0
5	QPSK	1	12	22.14	22.55	22.07		
5	QPSK	1	24	22.37	22.40	22.02		
5	QPSK	12	0	21.15	21.46	21.09	23	1
5	QPSK	12	6	21.20	21.63	21.17		
5	QPSK	12	11	21.23	21.58	21.03		
5	QPSK	25	0	21.17	21.42	21.03	23	1
5	16QAM	1	0	21.09	21.26	21.25		
5	16QAM	1	12	21.14	21.63	21.15		
5	16QAM	1	24	21.43	21.45	21.02	22	2
5	16QAM	12	0	20.12	20.60	20.18		
5	16QAM	12	6	20.19	20.56	20.20		
5	16QAM	12	11	20.39	20.54	20.16	22	2
5	16QAM	25	0	20.10	20.46	20.02		



<LTE Band 5>

BW [MHz]	Modulation	RB Size	RB Offset	Power Low Ch. / Freq.	Power Middle Ch. / Freq.	Power High Ch. / Freq.	Tune up Limit (dBm)	MPR (dB)
Channel				20450	20525	20600		
Frequency (MHz)				829	836.5	844		
10	QPSK	1	0	22.78	22.81	22.77	24	0
10	QPSK	1	24	22.59	22.70	22.58		
10	QPSK	1	49	22.51	22.73	22.67		
10	QPSK	25	0	21.76	21.77	21.71	23	1
10	QPSK	25	12	21.70	21.73	21.68		
10	QPSK	25	24	21.66	21.62	21.67		
10	QPSK	50	0	21.66	21.71	21.53		
10	16QAM	1	0	21.51	21.75	21.75	23	1
10	16QAM	1	24	21.59	21.80	21.79		
10	16QAM	1	49	21.56	21.67	21.61		
10	16QAM	25	0	20.69	20.78	20.58	22	2
10	16QAM	25	12	20.63	20.71	20.62		
10	16QAM	25	24	20.41	20.56	20.57		
10	16QAM	50	0	20.51	20.67	20.55		
Channel				20425	20525	20625	Tune up Limit (dBm)	MPR (dB)
Frequency (MHz)				826.5	836.5	846.5		
5	QPSK	1	0	22.62	22.68	22.50	24	0
5	QPSK	1	12	22.71	22.59	22.77		
5	QPSK	1	24	22.55	22.60	22.65		
5	QPSK	12	0	21.73	21.75	21.68	23	1
5	QPSK	12	6	21.70	21.80	21.67		
5	QPSK	12	11	21.72	21.69	21.68		
5	QPSK	25	0	21.54	21.71	21.66		
5	16QAM	1	0	21.71	21.71	21.54	23	1
5	16QAM	1	12	21.65	21.65	21.73		
5	16QAM	1	24	21.58	21.58	21.60		
5	16QAM	12	0	20.64	20.75	20.75	22	2
5	16QAM	12	6	20.70	20.79	20.80		
5	16QAM	12	11	20.65	20.67	20.64		
5	16QAM	25	0	20.55	20.73	20.63		
Channel				20415	20525	20635	Tune up Limit (dBm)	MPR (dB)
Frequency (MHz)				825.5	836.5	847.5		
3	QPSK	1	0	22.56	22.64	22.63	24	0
3	QPSK	1	7	22.66	22.53	22.62		
3	QPSK	1	14	22.61	22.63	22.55		
3	QPSK	8	0	21.62	21.75	21.69	23	1
3	QPSK	8	4	21.67	21.70	21.68		
3	QPSK	8	7	21.66	21.64	21.76		
3	QPSK	15	0	21.53	21.82	21.72		
3	16QAM	1	0	21.57	21.77	21.63	23	1
3	16QAM	1	7	21.58	21.67	21.64		
3	16QAM	1	14	21.69	21.60	21.54		
3	16QAM	8	0	20.56	20.71	20.73	22	2
3	16QAM	8	4	20.48	20.59	20.64		
3	16QAM	8	7	20.52	20.49	20.63		
3	16QAM	15	0	20.61	20.82	20.58		



Channel				20407	20525	20643	Tune up Limit (dBm)	Target MPR (dB)
Frequency (MHz)				824.7	836.5	848.3		
1.4	QPSK	1	0	22.58	22.76	22.66	24	0
1.4	QPSK	1	2	22.66	22.59	22.63		
1.4	QPSK	1	5	22.74	22.64	22.65		
1.4	QPSK	3	0	22.57	22.75	22.68		
1.4	QPSK	3	1	22.68	22.65	22.67		
1.4	QPSK	3	2	22.57	22.49	22.61		
1.4	QPSK	6	0	21.67	21.72	21.77	23	1
1.4	16QAM	1	0	21.58	21.68	21.56	23	1
1.4	16QAM	1	2	21.54	21.55	21.59		
1.4	16QAM	1	5	21.60	21.62	21.58		
1.4	16QAM	3	0	21.72	21.82	21.59		
1.4	16QAM	3	1	21.63	21.63	21.54		
1.4	16QAM	3	2	21.62	21.51	21.61		
1.4	16QAM	6	0	20.68	20.82	20.64	22	2



<LTE Band 4>

BW [MHz]	Modulation	RB Size	RB Offset	Power Low Ch. / Freq.	Power Middle Ch. / Freq.	Power High Ch. / Freq.	Tune up Limit (dBm)	MPR (dB)
Channel				20050	20175	20300		
Frequency (MHz)				1720	1732.5	1745		
20	QPSK	1	0	22.90	22.95	22.98	24	0
20	QPSK	1	49	22.76	22.86	22.96		
20	QPSK	1	99	22.66	22.82	22.94		
20	QPSK	50	0	21.61	21.62	21.66	23	1
20	QPSK	50	24	21.41	21.61	21.61		
20	QPSK	50	49	21.57	21.47	21.65		
20	QPSK	100	0	21.49	21.69	21.75	23	1
20	16QAM	1	0	21.82	21.98	21.97		
20	16QAM	1	49	21.84	22.01	21.94		
20	16QAM	1	99	21.73	21.97	21.99	22	2
20	16QAM	50	0	20.61	20.69	20.63		
20	16QAM	50	24	20.59	20.48	20.53		
20	16QAM	50	49	20.54	20.60	20.58	22	2
20	16QAM	100	0	20.50	20.74	20.62		
Channel				20025	20175	20325		
Frequency (MHz)				1717.5	1732.5	1747.5		
15	QPSK	1	0	22.79	22.90	22.85	24	0
15	QPSK	1	37	22.84	22.84	22.94		
15	QPSK	1	74	22.56	22.89	22.66		
15	QPSK	36	0	21.51	21.82	21.60	23	1
15	QPSK	36	18	21.71	21.75	21.72		
15	QPSK	36	37	21.51	21.60	21.63		
15	QPSK	75	0	21.54	21.78	21.60	23	1
15	16QAM	1	0	21.80	21.96	21.87		
15	16QAM	1	37	21.76	21.98	21.92		
15	16QAM	1	74	21.70	21.94	21.76	22	2
15	16QAM	36	0	20.60	20.81	20.69		
15	16QAM	36	18	20.63	20.74	20.62		
15	16QAM	36	37	20.61	20.73	20.60	22	2
15	16QAM	75	0	20.52	20.70	20.60		
Channel				20000	20175	20350		
Frequency (MHz)				1715	1732.5	1750		
10	QPSK	1	0	22.74	22.97	22.91	24	0
10	QPSK	1	24	22.77	22.96	22.85		
10	QPSK	1	49	22.73	22.90	22.94		
10	QPSK	25	0	21.70	21.98	21.76	23	1
10	QPSK	25	12	21.74	21.86	21.73		
10	QPSK	25	24	21.71	21.79	21.69		
10	QPSK	50	0	21.38	21.81	21.56	23	1
10	16QAM	1	0	21.73	22.14	21.98		
10	16QAM	1	24	21.83	21.85	21.90		
10	16QAM	1	49	21.64	21.98	21.82	22	2
10	16QAM	25	0	20.79	20.84	20.76		
10	16QAM	25	12	20.71	20.79	20.77		
10	16QAM	25	24	20.78	20.71	20.76	22	2
10	16QAM	50	0	20.53	20.77	20.62		



Channel				19975	20175	20375	Tune up Limit (dBm)	MPR (dB)
Frequency (MHz)				1712.5	1732.5	1752.5		
5	QPSK	1	0	22.71	22.97	22.92	24	0
5	QPSK	1	12	22.85	22.93	22.83		
5	QPSK	1	24	22.68	22.94	22.83		
5	QPSK	12	0	21.75	22.03	21.91	23	1
5	QPSK	12	6	21.87	21.95	21.87		
5	QPSK	12	11	21.68	21.95	21.75		
5	QPSK	25	0	21.60	21.92	21.71		
5	16QAM	1	0	21.85	21.93	21.92	23	1
5	16QAM	1	12	21.78	22.00	21.90		
5	16QAM	1	24	21.69	22.00	21.85		
5	16QAM	12	0	20.80	21.11	20.84	22	2
5	16QAM	12	6	20.86	20.95	20.75		
5	16QAM	12	11	20.81	20.87	20.84		
5	16QAM	25	0	20.78	20.88	20.61		
5	16QAM	25	0	20.78	20.88	20.61		
Channel				19965	20175	20385	Tune up Limit (dBm)	MPR (dB)
Frequency (MHz)				1711.5	1732.5	1753.5		
3	QPSK	1	0	22.82	22.92	22.79	24	0
3	QPSK	1	7	22.62	22.84	22.85		
3	QPSK	1	14	22.62	22.90	22.86		
3	QPSK	8	0	21.77	22.06	21.84	23	1
3	QPSK	8	4	21.63	21.84	21.80		
3	QPSK	8	7	21.66	21.92	21.85		
3	QPSK	15	0	21.73	22.01	21.82		
3	QPSK	15	0	21.73	22.01	21.82		
3	16QAM	1	0	21.86	21.98	21.80	23	1
3	16QAM	1	7	21.67	22.00	21.83		
3	16QAM	1	14	21.63	21.95	21.86		
3	16QAM	8	0	20.66	21.07	20.81	22	2
3	16QAM	8	4	20.60	20.79	20.71		
3	16QAM	8	7	20.66	20.88	20.77		
3	16QAM	8	7	20.66	20.88	20.77		
3	16QAM	15	0	20.60	21.04	20.78		
3	16QAM	15	0	20.60	21.04	20.78		
Channel				19957	20175	20393	Tune up Limit (dBm)	MPR (dB)
Frequency (MHz)				1710.7	1732.5	1754.3		
1.4	QPSK	1	0	22.68	22.96	22.85	24	0
1.4	QPSK	1	2	22.70	22.94	22.88		
1.4	QPSK	1	5	22.62	22.95	22.96		
1.4	QPSK	3	0	22.67	22.95	22.83		
1.4	QPSK	3	1	22.64	22.94	22.87		
1.4	QPSK	3	2	22.59	22.86	22.92		
1.4	QPSK	6	0	21.72	22.01	21.86	23	1
1.4	16QAM	1	0	21.73	22.07	22.00	23	1
1.4	16QAM	1	2	21.64	21.98	22.00		
1.4	16QAM	1	5	21.66	22.01	21.95		
1.4	16QAM	3	0	21.66	22.06	21.95		
1.4	16QAM	3	1	21.68	21.98	21.84		
1.4	16QAM	3	2	21.71	22.01	21.85		
1.4	16QAM	6	0	20.67	21.02	20.85		



<LTE Band 2>

BW [MHz]	Modulation	RB Size	RB Offset	Power Low Ch. / Freq.	Power Middle Ch. / Freq.	Power High Ch. / Freq.	Tune up Limit (dBm)	MPR (dB)
Channel				18700	18900	19100		
Frequency (MHz)				1860	1880	1900		
20	QPSK	1	0	23.12	23.02	22.87	24	0
20	QPSK	1	49	23.07	22.94	22.61		
20	QPSK	1	99	23.00	22.76	22.62		
20	QPSK	50	0	21.99	21.77	21.50	23	1
20	QPSK	50	24	21.83	21.76	21.48		
20	QPSK	50	49	21.72	21.68	21.46		
20	QPSK	100	0	21.86	21.85	21.51		
20	16QAM	1	0	22.08	22.14	21.76	23	1
20	16QAM	1	49	22.07	22.01	21.80		
20	16QAM	1	99	22.09	21.92	21.85		
20	16QAM	50	0	20.96	20.76	20.52	22	2
20	16QAM	50	24	20.77	20.72	20.32		
20	16QAM	50	49	20.72	20.69	20.54		
20	16QAM	100	0	20.81	20.70	20.51		
Channel				18675	18900	19125	Tune up Limit (dBm)	MPR (dB)
Frequency (MHz)				1857.5	1880	1902.5		
15	QPSK	1	0	23.05	22.84	22.74	24	0
15	QPSK	1	37	23.06	22.96	22.76		
15	QPSK	1	74	22.96	22.85	22.83		
15	QPSK	36	0	22.04	21.81	21.54	23	1
15	QPSK	36	18	21.83	21.88	21.64		
15	QPSK	36	37	21.85	21.72	21.56		
15	QPSK	75	0	21.77	21.78	21.52		
15	16QAM	1	0	22.00	21.97	21.68	23	1
15	16QAM	1	37	22.12	21.94	21.75		
15	16QAM	1	74	22.07	22.04	21.86		
15	16QAM	36	0	21.04	20.77	20.56	22	2
15	16QAM	36	18	20.88	20.69	20.62		
15	16QAM	36	37	20.77	20.81	20.57		
15	16QAM	75	0	20.73	20.69	20.60		
Channel				18650	18900	19150	Tune up Limit (dBm)	MPR (dB)
Frequency (MHz)				1855	1880	1905		
10	QPSK	1	0	23.07	22.94	22.70	24	0
10	QPSK	1	24	22.91	23.01	22.79		
10	QPSK	1	49	22.95	22.91	22.74		
10	QPSK	25	0	21.95	22.03	21.70	23	1
10	QPSK	25	12	22.02	21.87	21.60		
10	QPSK	25	24	21.95	21.94	21.67		
10	QPSK	50	0	21.74	21.61	21.56		
10	16QAM	1	0	22.03	22.03	21.76	23	1
10	16QAM	1	24	21.97	22.10	21.78		
10	16QAM	1	49	21.96	22.02	21.89		
10	16QAM	25	0	21.03	20.87	20.67	22	2
10	16QAM	25	12	21.21	20.82	20.73		
10	16QAM	25	24	20.89	20.72	20.75		
10	16QAM	50	0	20.77	20.81	20.54		



Channel				18625	18900	19175	Tune up Limit (dBm)	MPR (dB)
Frequency (MHz)				1852.5	1880	1907.5		
5	QPSK	1	0	22.98	22.96	22.72	24	0
5	QPSK	1	12	22.86	23.00	22.84		
5	QPSK	1	24	22.99	22.94	22.82		
5	QPSK	12	0	21.94	22.04	21.90	23	1
5	QPSK	12	6	21.84	21.99	21.80		
5	QPSK	12	11	21.94	21.98	21.97		
5	QPSK	25	0	21.71	21.83	21.68	23	1
5	16QAM	1	0	21.96	21.93	21.75		
5	16QAM	1	12	21.88	21.98	21.90		
5	16QAM	1	24	21.91	22.00	21.95	22	2
5	16QAM	12	0	21.10	21.17	20.89		
5	16QAM	12	6	20.92	21.01	20.81		
5	16QAM	12	11	21.02	21.11	20.90	22	2
5	16QAM	25	0	20.79	20.78	20.75		
5	16QAM	25	0	20.79	20.78	20.75		
Channel				18615	18900	19185	Tune up Limit (dBm)	MPR (dB)
Frequency (MHz)				1851.5	1880	1908.5		
3	QPSK	1	0	23.08	22.98	22.78	24	0
3	QPSK	1	7	22.89	22.98	22.77		
3	QPSK	1	14	23.08	22.92	22.77		
3	QPSK	8	0	22.09	22.03	21.97	23	1
3	QPSK	8	4	21.95	22.03	21.82		
3	QPSK	8	7	21.86	22.04	21.86		
3	QPSK	15	0	21.97	22.02	21.93	23	1
3	16QAM	1	0	22.00	21.97	21.82		
3	16QAM	1	7	21.86	22.05	21.80		
3	16QAM	1	14	21.97	22.02	21.80	22	2
3	16QAM	8	0	20.99	20.98	20.69		
3	16QAM	8	4	20.81	20.93	20.76		
3	16QAM	8	7	20.82	20.94	20.86	22	2
3	16QAM	15	0	20.93	20.92	20.80		
3	16QAM	15	0	20.93	20.92	20.80		
Channel				18607	18900	19193	Tune up Limit (dBm)	MPR (dB)
Frequency (MHz)				1850.7	1880	1909.3		
1.4	QPSK	1	0	23.06	22.99	22.79	24	0
1.4	QPSK	1	2	22.88	23.00	22.76		
1.4	QPSK	1	5	22.88	22.97	22.77		
1.4	QPSK	3	0	23.04	22.96	22.75	24	0
1.4	QPSK	3	1	22.99	22.95	22.76		
1.4	QPSK	3	2	22.95	23.01	22.73		
1.4	QPSK	6	0	22.05	22.09	21.89	23	1
1.4	16QAM	1	0	22.11	22.08	21.94	23	1
1.4	16QAM	1	2	21.88	22.07	21.87		
1.4	16QAM	1	5	21.88	21.93	21.89		
1.4	16QAM	3	0	22.15	22.04	21.93	23	1
1.4	16QAM	3	1	21.88	22.02	21.88		
1.4	16QAM	3	2	21.87	22.12	21.87		
1.4	16QAM	6	0	20.96	21.11	20.94	22	2



<LTE Band 25>

BW [MHz]	Modulation	RB Size	RB Offset	Power Low Ch. / Freq.	Power Middle Ch. / Freq.	Power High Ch. / Freq.	Tune up Limit (dBm)	MPR (dB)
Channel				26140	26340	26590		
Frequency (MHz)				1860	1880	1905		
20	QPSK	1	0	23.06	23.09	22.93	24	0
20	QPSK	1	49	23.05	22.99	22.87		
20	QPSK	1	99	22.96	23.04	23.08		
20	QPSK	50	0	21.75	21.92	21.81	23	1
20	QPSK	50	24	21.70	21.72	21.70		
20	QPSK	50	49	21.70	21.86	21.74		
20	QPSK	100	0	21.87	21.89	21.80		
20	16QAM	1	0	22.07	22.12	21.93	23	1
20	16QAM	1	49	22.11	21.90	21.97		
20	16QAM	1	99	22.01	22.01	22.12		
20	16QAM	50	0	20.69	20.77	20.73	22	2
20	16QAM	50	24	20.84	20.76	20.73		
20	16QAM	50	49	20.77	20.92	20.76		
20	16QAM	100	0	21.09	20.91	20.85		
Channel				26115	26340	26615	Tune up Limit (dBm)	MPR (dB)
Frequency (MHz)				1857.5	1880	1907.5		
15	QPSK	1	0	22.95	22.96	23.03	24	0
15	QPSK	1	37	23.03	22.84	22.95		
15	QPSK	1	74	22.90	22.99	22.96		
15	QPSK	36	0	21.81	21.79	21.95	23	1
15	QPSK	36	18	21.82	21.80	21.84		
15	QPSK	36	37	21.74	22.07	21.94		
15	QPSK	75	0	21.93	21.84	21.77		
15	16QAM	1	0	22.02	22.06	22.15	23	1
15	16QAM	1	37	22.13	22.07	22.07		
15	16QAM	1	74	21.91	21.98	22.09		
15	16QAM	36	0	20.83	21.00	20.89	22	2
15	16QAM	36	18	20.85	20.79	20.89		
15	16QAM	36	37	20.67	20.93	20.89		
15	16QAM	75	0	20.84	20.90	20.85		
Channel				26090	26340	26640	Tune up Limit (dBm)	MPR (dB)
Frequency (MHz)				1855	1880	1910		
10	QPSK	1	0	22.92	23.06	23.06	24	0
10	QPSK	1	24	23.07	22.93	22.97		
10	QPSK	1	49	22.88	23.05	23.03		
10	QPSK	25	0	21.81	21.98	22.05	23	1
10	QPSK	25	12	21.82	21.80	21.95		
10	QPSK	25	24	21.71	22.13	21.99		
10	QPSK	50	0	21.86	21.79	21.92		
10	16QAM	1	0	21.95	22.08	22.06	23	1
10	16QAM	1	24	22.15	21.89	22.05		
10	16QAM	1	49	21.87	22.02	22.11		
10	16QAM	25	0	20.89	21.04	21.04	22	2
10	16QAM	25	12	21.09	20.78	20.96		
10	16QAM	25	24	20.76	21.02	21.04		
10	16QAM	50	0	21.09	20.90	20.86		



Channel				26065	26340	26665	Tune up Limit (dBm)	MPR (dB)
Frequency (MHz)				1852.5	1880	1912.5		
5	QPSK	1	0	22.95	23.02	23.02	24	0
5	QPSK	1	12	23.03	22.90	22.99		
5	QPSK	1	24	22.94	23.01	23.00		
5	QPSK	12	0	21.96	22.04	22.18	23	1
5	QPSK	12	6	21.86	22.01	22.14		
5	QPSK	12	11	21.89	22.18	22.04		
5	QPSK	25	0	21.96	22.10	22.17		
5	16QAM	1	0	21.82	22.04	22.08	23	1
5	16QAM	1	12	21.90	22.08	22.07		
5	16QAM	1	24	21.86	22.16	22.09		
5	16QAM	12	0	20.99	21.13	21.31	22	2
5	16QAM	12	6	21.08	20.88	21.22		
5	16QAM	12	11	21.04	21.24	21.21		
5	16QAM	25	0	20.93	21.14	21.10		
5	16QAM	25	0	20.93	21.14	21.10		
Channel				26055	26340	26675	Tune up Limit (dBm)	MPR (dB)
Frequency (MHz)				1851.5	1880	1913.5		
3	QPSK	1	0	22.84	22.99	22.94	24	0
3	QPSK	1	7	23.03	22.89	23.00		
3	QPSK	1	14	22.95	22.98	23.01		
3	QPSK	8	0	22.06	22.14	22.26	23	1
3	QPSK	8	4	22.05	21.93	22.25		
3	QPSK	8	7	21.80	22.14	22.02		
3	QPSK	15	0	22.18	22.16	22.20		
3	QPSK	15	0	22.18	22.16	22.20		
3	16QAM	1	0	21.91	22.14	22.12	23	1
3	16QAM	1	7	22.05	21.95	22.20		
3	16QAM	1	14	21.88	22.19	22.04		
3	16QAM	8	0	20.90	21.09	21.23	22	2
3	16QAM	8	4	20.97	20.86	21.11		
3	16QAM	8	7	20.91	21.21	21.03		
3	16QAM	8	7	20.91	21.21	21.03		
3	16QAM	15	0	21.09	21.11	21.19		
Channel				26047	26340	26683	Tune up Limit (dBm)	MPR (dB)
Frequency (MHz)				1850.7	1880	1914.3		
1.4	QPSK	1	0	22.91	22.98	22.94	24	0
1.4	QPSK	1	2	23.02	22.83	22.94		
1.4	QPSK	1	5	22.81	22.97	22.89		
1.4	QPSK	3	0	22.86	22.92	23.00		
1.4	QPSK	3	1	22.79	22.93	22.92		
1.4	QPSK	3	2	22.89	22.83	22.98		
1.4	QPSK	6	0	22.11	22.23	22.25	23	1
1.4	16QAM	1	0	21.85	22.12	22.20	23	1
1.4	16QAM	1	2	21.91	21.99	22.10		
1.4	16QAM	1	5	21.85	22.26	22.14		
1.4	16QAM	3	0	21.93	21.98	22.30		
1.4	16QAM	3	1	22.16	21.99	22.24		
1.4	16QAM	3	2	21.94	22.20	22.06		
1.4	16QAM	6	0	21.35	21.23	21.16		



Reduced Power Mode (Proximity Sensor active)

<LTE Band 17>

BW [MHz]	Modulation	RB Size	RB Offset	Power Low Ch. / Freq.	Power Middle Ch. / Freq.	Power High Ch. / Freq.	Tune up Limit (dBm)	MPR (dB)
Channel				23780	23790	23800		
Frequency (MHz)				709	710	711		
10	QPSK	1	0	21.46	21.60	21.35	23	0
10	QPSK	1	24	21.39	21.59	21.33		
10	QPSK	1	49	21.23	21.01	21.02		
10	QPSK	25	0	21.39	21.53	21.33	23	1
10	QPSK	25	12	21.37	21.52	21.31		
10	QPSK	25	24	21.36	21.21	21.23		
10	QPSK	50	0	21.27	21.31	21.22		
10	16QAM	1	0	21.11	21.46	21.19	23	1
10	16QAM	1	24	21.31	21.55	21.25		
10	16QAM	1	49	21.21	21.01	21.09		
10	16QAM	25	0	21.08	21.40	21.22	23	2
10	16QAM	25	12	21.27	21.38	21.22		
10	16QAM	25	24	21.27	21.09	21.10		
10	16QAM	50	0	21.13	21.29	21.09		
Channel				23755	23790	23825	Tune up Limit (dBm)	MPR (dB)
Frequency (MHz)				706.5	710	713.5		
5	QPSK	1	0	21.50	21.56	21.45	23	0
5	QPSK	1	12	21.45	21.38	21.44		
5	QPSK	1	24	21.43	21.04	21.36		
5	QPSK	12	0	21.42	21.55	21.50	23	1
5	QPSK	12	6	21.38	21.35	21.43		
5	QPSK	12	11	21.41	21.28	21.48		
5	QPSK	25	0	21.33	21.17	21.41	23	1
5	16QAM	1	0	21.21	21.47	21.46		
5	16QAM	1	12	21.42	21.38	21.48		
5	16QAM	1	24	21.40	21.01	21.33	23	2
5	16QAM	12	0	21.15	21.18	21.44		
5	16QAM	12	6	21.33	21.28	21.31		
5	16QAM	12	11	21.32	21.09	21.38		
5	16QAM	25	0	21.08	21.05	21.32		



<LTE Band 13>

BW [MHz]	Modulation	RB Size	RB Offset	Power Low Ch. / Freq.	Power Middle Ch. / Freq.	Power High Ch. / Freq.	Tune up Limit (dBm)	MPR (dB)
Channel					23230			
Frequency (MHz)					782			
10	QPSK	1	0		20.45		21	0
10	QPSK	1	24		20.39			
10	QPSK	1	49		20.38			
10	QPSK	25	0		20.42		21	1
10	QPSK	25	12		20.31			
10	QPSK	25	24		20.32			
10	QPSK	50	0		20.23			
10	16QAM	1	0		20.39		21	1
10	16QAM	1	24		20.30			
10	16QAM	1	49		20.37			
10	16QAM	25	0		20.13		21	2
10	16QAM	25	12		20.32			
10	16QAM	25	24		20.33			
10	16QAM	50	0		20.15			
Channel				23205	23230	23255	Tune up Limit (dBm)	MPR (dB)
Frequency (MHz)				779.5	782	784.5		
5	QPSK	1	0	20.13	20.43	20.39	21	0
5	QPSK	1	12	20.26	20.36	20.30		
5	QPSK	1	24	20.44	20.36	20.32		
5	QPSK	12	0	20.12	20.28	20.35	21	1
5	QPSK	12	6	20.23	20.41	20.36		
5	QPSK	12	11	20.25	20.40	20.32		
5	QPSK	25	0	20.11	20.36	20.38		
5	16QAM	1	0	20.10	20.42	20.39	21	1
5	16QAM	1	12	20.27	20.38	20.29		
5	16QAM	1	24	20.41	20.36	20.28		
5	16QAM	12	0	20.08	20.34	20.37	21	2
5	16QAM	12	6	20.29	20.31	20.38		
5	16QAM	12	11	20.32	20.31	20.28		
5	16QAM	12	11	20.32	20.31	20.28		
5	16QAM	25	0	20.07	20.33	20.26		



<LTE Band 5>

BW [MHz]	Modulation	RB Size	RB Offset	Power Low Ch. / Freq.	Power Middle Ch. / Freq.	Power High Ch. / Freq.	Tune up Limit (dBm)	MPR (dB)
Channel				20450	20525	20600		
Frequency (MHz)				829	836.5	844		
10	QPSK	1	0	18.58	18.71	18.68	19	0
10	QPSK	1	24	18.47	18.70	18.53		
10	QPSK	1	49	18.52	18.56	18.38		
10	QPSK	25	0	18.47	18.58	18.57	19	1
10	QPSK	25	12	18.43	18.55	18.49		
10	QPSK	25	24	18.45	18.54	18.36		
10	QPSK	50	0	18.40	18.53	18.39		
10	16QAM	1	0	18.57	18.70	18.65	19	1
10	16QAM	1	24	18.56	18.62	18.58		
10	16QAM	1	49	18.52	18.55	18.36		
10	16QAM	25	0	18.47	18.45	18.53	19	2
10	16QAM	25	12	18.42	18.55	18.41		
10	16QAM	25	24	18.42	18.53	18.35		
10	16QAM	50	0	18.35	18.50	18.39		
Channel				20425	20525	20625		
Frequency (MHz)				826.5	836.5	846.5		
5	QPSK	1	0	18.55	18.48	18.55	19	0
5	QPSK	1	12	18.48	18.69	18.46		
5	QPSK	1	24	18.52	18.58	18.41		
5	QPSK	12	0	18.54	18.56	18.51	19	1
5	QPSK	12	6	18.54	18.65	18.45		
5	QPSK	12	11	18.45	18.51	18.37		
5	QPSK	25	0	18.49	18.59	18.36		
5	16QAM	1	0	18.54	18.51	18.54	19	1
5	16QAM	1	12	18.47	18.62	18.45		
5	16QAM	1	24	18.51	18.61	18.39		
5	16QAM	12	0	18.52	18.64	18.53	19	2
5	16QAM	12	6	18.47	18.67	18.42		
5	16QAM	12	11	18.53	18.61	18.40		
5	16QAM	25	0	18.44	18.54	18.32		
Channel				20415	20525	20635		
Frequency (MHz)				825.5	836.5	847.5		
3	QPSK	1	0	18.57	18.67	18.47	19	0
3	QPSK	1	7	18.53	18.65	18.37		
3	QPSK	1	14	18.48	18.64	18.41		
3	QPSK	8	0	18.49	18.66	18.43	19	1
3	QPSK	8	4	18.48	18.59	18.38		
3	QPSK	8	7	18.50	18.59	18.43		
3	QPSK	15	0	18.51	18.57	18.32		
3	16QAM	1	0	18.56	18.65	18.41	19	1
3	16QAM	1	7	18.46	18.60	18.39		
3	16QAM	1	14	18.44	18.63	18.34		
3	16QAM	8	0	18.44	18.60	18.34	19	2
3	16QAM	8	4	18.46	18.63	18.27		
3	16QAM	8	7	18.47	18.63	18.31		
3	16QAM	15	0	18.53	18.63	18.32		



Channel				20407	20525	20643	Tune up Limit (dBm)	Target MPR (dB)
Frequency (MHz)				824.7	836.5	848.3		
1.4	QPSK	1	0	18.61	18.66	18.49	19	0
1.4	QPSK	1	2	18.60	18.65	18.47		
1.4	QPSK	1	5	18.58	18.65	18.43		
1.4	QPSK	3	0	18.53	18.64	18.41		
1.4	QPSK	3	1	18.57	18.62	18.43		
1.4	QPSK	3	2	18.57	18.59	18.42		
1.4	QPSK	6	0	18.53	18.59	18.41	19	1
1.4	16QAM	1	0	18.50	18.66	18.41	19	1
1.4	16QAM	1	2	18.46	18.62	18.42		
1.4	16QAM	1	5	18.46	18.64	18.38		
1.4	16QAM	3	0	18.44	18.57	18.45		
1.4	16QAM	3	1	18.48	18.63	18.47		
1.4	16QAM	3	2	18.49	18.65	18.46		
1.4	16QAM	6	0	18.45	18.61	18.48	19	2



<LTE Band 4>

BW [MHz]	Modulation	RB Size	RB Offset	Power Low Ch. / Freq.	Power Middle Ch. / Freq.	Power High Ch. / Freq.	Tune up Limit (dBm)	MPR (dB)
Channel				20050	20175	20300		
Frequency (MHz)				1720	1732.5	1745		
20	QPSK	1	0	17.46	17.36	17.63	18	0
20	QPSK	1	49	17.38	17.32	17.57		
20	QPSK	1	99	17.36	17.31	17.49		
20	QPSK	50	0	17.30	17.36	17.39	18	1
20	QPSK	50	24	17.29	17.26	17.37		
20	QPSK	50	49	17.28	17.26	17.39		
20	QPSK	100	0	17.30	17.29	17.41	18	1
20	16QAM	1	0	17.43	17.39	17.62		
20	16QAM	1	49	17.41	17.40	17.60		
20	16QAM	1	99	17.40	17.50	17.48	18	2
20	16QAM	50	0	17.14	17.29	17.39		
20	16QAM	50	24	17.19	17.22	17.32		
20	16QAM	50	49	17.18	17.28	17.28	18	2
20	16QAM	100	0	17.26	17.27	17.37		
Channel				20025	20175	20325		
Frequency (MHz)				1717.5	1732.5	1747.5		
15	QPSK	1	0	17.40	17.51	17.59	18	0
15	QPSK	1	37	17.40	17.47	17.56		
15	QPSK	1	74	17.34	17.56	17.54		
15	QPSK	36	0	17.26	17.38	17.42	18	1
15	QPSK	36	18	17.21	17.32	17.44		
15	QPSK	36	37	17.30	17.36	17.37		
15	QPSK	75	0	17.17	17.36	17.36	18	1
15	16QAM	1	0	17.35	17.44	17.59		
15	16QAM	1	37	17.43	17.38	17.55		
15	16QAM	1	74	17.34	17.43	17.51	18	2
15	16QAM	36	0	17.24	17.39	17.37		
15	16QAM	36	18	17.18	17.27	17.38		
15	16QAM	36	37	17.25	17.29	17.39	18	2
15	16QAM	75	0	17.17	17.24	17.32		
Channel				20000	20175	20350		
Frequency (MHz)				1715	1732.5	1750		
10	QPSK	1	0	17.39	17.46	17.57	18	0
10	QPSK	1	24	17.24	17.36	17.53		
10	QPSK	1	49	17.38	17.44	17.49		
10	QPSK	25	0	17.21	17.42	17.43	18	1
10	QPSK	25	12	17.20	17.33	17.43		
10	QPSK	25	24	17.29	17.29	17.44		
10	QPSK	50	0	17.16	17.31	17.37	18	1
10	16QAM	1	0	17.36	17.48	17.53		
10	16QAM	1	24	17.24	17.40	17.56		
10	16QAM	1	49	17.38	17.37	17.49	18	2
10	16QAM	25	0	17.25	17.32	17.41		
10	16QAM	25	12	17.17	17.35	17.43		
10	16QAM	25	24	17.21	17.25	17.38	18	2
10	16QAM	50	0	17.12	17.29	17.38		



Channel				19975	20175	20375	Tune up Limit (dBm)	MPR (dB)
Frequency (MHz)				1712.5	1732.5	1752.5		
5	QPSK	1	0	17.37	17.53	17.56	18	0
5	QPSK	1	12	17.36	17.35	17.58		
5	QPSK	1	24	17.23	17.38	17.53		
5	QPSK	12	0	17.34	17.44	17.56	18	1
5	QPSK	12	6	17.29	17.36	17.59		
5	QPSK	12	11	17.34	17.30	17.53		
5	QPSK	25	0	17.16	17.39	17.50		
5	16QAM	1	0	17.31	17.49	17.55	18	1
5	16QAM	1	12	17.38	17.37	17.58		
5	16QAM	1	24	17.27	17.41	17.56		
5	16QAM	12	0	17.37	17.51	17.58	18	2
5	16QAM	12	6	17.34	17.33	17.54		
5	16QAM	12	11	17.30	17.35	17.55		
5	16QAM	25	0	17.19	17.33	17.42		
5	16QAM	25	0	17.19	17.33	17.42		
Channel				19965	20175	20385	Tune up Limit (dBm)	MPR (dB)
Frequency (MHz)				1711.5	1732.5	1753.5		
3	QPSK	1	0	17.31	17.52	17.56	18	0
3	QPSK	1	7	17.29	17.34	17.55		
3	QPSK	1	14	17.34	17.37	17.54		
3	QPSK	8	0	17.30	17.30	17.51	18	1
3	QPSK	8	4	17.29	17.40	17.54		
3	QPSK	8	7	17.34	17.37	17.54		
3	QPSK	15	0	17.23	17.34	17.52		
3	QPSK	15	0	17.23	17.34	17.52		
3	16QAM	1	0	17.30	17.52	17.50	18	1
3	16QAM	1	7	17.29	17.40	17.55		
3	16QAM	1	14	17.32	17.36	17.57		
3	16QAM	8	0	17.23	17.24	17.49	18	2
3	16QAM	8	4	17.22	17.25	17.44		
3	16QAM	8	7	17.23	17.26	17.51		
3	16QAM	8	7	17.23	17.26	17.51		
3	16QAM	15	0	17.32	17.27	17.51		
Channel				19957	20175	20393	Tune up Limit (dBm)	MPR (dB)
Frequency (MHz)				1710.7	1732.5	1754.3		
1.4	QPSK	1	0	17.33	17.38	17.59	18	0
1.4	QPSK	1	2	17.37	17.36	17.60		
1.4	QPSK	1	5	17.37	17.34	17.58		
1.4	QPSK	3	0	17.37	17.37	17.61		
1.4	QPSK	3	1	17.30	17.30	17.57		
1.4	QPSK	3	2	17.34	17.28	17.59		
1.4	QPSK	6	0	17.33	17.31	17.53	18	1
1.4	16QAM	1	0	17.28	17.36	17.49	18	1
1.4	16QAM	1	2	17.29	17.27	17.52		
1.4	16QAM	1	5	17.31	17.31	17.50		
1.4	16QAM	3	0	17.35	17.36	17.60		
1.4	16QAM	3	1	17.31	17.34	17.55		
1.4	16QAM	3	2	17.34	17.34	17.56		
1.4	16QAM	6	0	17.39	17.33	17.57		



<LTE Band 2>

BW [MHz]	Modulation	RB Size	RB Offset	Power Low Ch. / Freq.	Power Middle Ch. / Freq.	Power High Ch. / Freq.	Tune up Limit (dBm)	MPR (dB)
Channel				18700	18900	19100		
Frequency (MHz)				1860	1880	1900		
20	QPSK	1	0	18.99	18.92	18.97	20	0
20	QPSK	1	49	18.98	18.90	18.80		
20	QPSK	1	99	18.77	18.82	18.82		
20	QPSK	50	0	18.87	18.79	18.67	20	1
20	QPSK	50	24	18.78	18.74	18.64		
20	QPSK	50	49	18.72	18.66	18.58		
20	QPSK	100	0	18.79	18.71	18.77		
20	16QAM	1	0	18.95	18.95	18.85	20	1
20	16QAM	1	49	18.91	18.92	18.78		
20	16QAM	1	99	18.77	18.80	18.75		
20	16QAM	50	0	18.77	18.75	18.49	20	2
20	16QAM	50	24	18.74	18.66	18.55		
20	16QAM	50	49	18.61	18.61	18.77		
20	16QAM	100	0	18.78	18.71	18.64		
Channel				18675	18900	19125	Tune up Limit (dBm)	MPR (dB)
Frequency (MHz)				1857.5	1880	1902.5		
15	QPSK	1	0	18.98	18.98	18.96	20	0
15	QPSK	1	37	18.96	18.97	18.87		
15	QPSK	1	74	18.87	18.82	18.82		
15	QPSK	36	0	18.70	18.78	18.73	20	1
15	QPSK	36	18	18.79	18.72	18.69		
15	QPSK	36	37	18.79	18.67	18.90		
15	QPSK	75	0	18.81	18.71	18.72		
15	16QAM	1	0	18.90	18.96	18.88	20	1
15	16QAM	1	37	18.82	18.87	18.86		
15	16QAM	1	74	18.83	18.76	18.76		
15	16QAM	36	0	18.70	18.77	18.66	20	2
15	16QAM	36	18	18.78	18.71	18.68		
15	16QAM	36	37	18.76	18.66	18.77		
15	16QAM	75	0	18.73	18.64	18.74		
Channel				18650	18900	19150	Tune up Limit (dBm)	MPR (dB)
Frequency (MHz)				1855	1880	1905		
10	QPSK	1	0	18.98	18.95	18.96	20	0
10	QPSK	1	24	18.92	18.93	18.89		
10	QPSK	1	49	18.96	18.79	18.93		
10	QPSK	25	0	18.82	18.88	18.82	20	1
10	QPSK	25	12	18.79	18.82	18.93		
10	QPSK	25	24	18.89	18.74	18.91		
10	QPSK	50	0	18.80	18.77	18.88		
10	16QAM	1	0	18.95	18.93	18.92	20	1
10	16QAM	1	24	18.92	18.92	18.90		
10	16QAM	1	49	18.94	18.73	18.85		
10	16QAM	25	0	18.78	18.83	18.83	20	2
10	16QAM	25	12	18.76	18.80	18.87		
10	16QAM	25	24	18.83	18.74	18.88		
10	16QAM	50	0	18.65	18.68	18.80		



Channel				18625	18900	19175	Tune up Limit (dBm)	MPR (dB)
Frequency (MHz)				1852.5	1880	1907.5		
5	QPSK	1	0	18.90	18.96	18.89	20	0
5	QPSK	1	12	18.84	18.92	18.88		
5	QPSK	1	24	18.86	18.90	18.88		
5	QPSK	12	0	18.81	18.95	18.80	20	1
5	QPSK	12	6	18.84	18.88	18.84		
5	QPSK	12	11	18.87	18.91	18.86		
5	QPSK	25	0	18.82	18.83	18.83		
5	16QAM	1	0	18.87	18.95	18.88	20	1
5	16QAM	1	12	18.86	18.93	18.83		
5	16QAM	1	24	18.81	18.91	18.87		
5	16QAM	12	0	18.84	18.93	18.79	20	2
5	16QAM	12	6	18.83	18.94	18.78		
5	16QAM	12	11	18.85	18.94	18.82		
5	16QAM	25	0	18.76	18.79	18.73		
5	16QAM	25	0	18.76	18.79	18.73		
Channel				18615	18900	19185	Tune up Limit (dBm)	MPR (dB)
Frequency (MHz)				1851.5	1880	1908.5		
3	QPSK	1	0	18.87	18.95	18.95	20	0
3	QPSK	1	7	18.86	18.92	18.92		
3	QPSK	1	14	18.82	18.88	18.91		
3	QPSK	8	0	18.86	18.90	18.90	20	1
3	QPSK	8	4	18.83	18.94	18.82		
3	QPSK	8	7	18.79	18.90	18.87		
3	QPSK	15	0	18.84	18.89	18.82		
3	16QAM	1	0	18.93	18.89	18.92	20	1
3	16QAM	1	7	18.91	18.83	18.91		
3	16QAM	1	14	18.90	18.85	18.90		
3	16QAM	8	0	18.81	18.85	18.77	20	2
3	16QAM	8	4	18.80	18.83	18.86		
3	16QAM	8	7	18.84	18.83	18.90		
3	16QAM	15	0	18.81	18.82	18.87		
3	16QAM	15	0	18.81	18.82	18.87		
Channel				18607	18900	19193	Tune up Limit (dBm)	MPR (dB)
Frequency (MHz)				1850.7	1880	1909.3		
1.4	QPSK	1	0	18.93	18.95	18.92	20	0
1.4	QPSK	1	2	18.92	18.93	18.90		
1.4	QPSK	1	5	18.85	18.94	18.86		
1.4	QPSK	3	0	18.88	18.94	18.83		
1.4	QPSK	3	1	18.92	18.93	18.83		
1.4	QPSK	3	2	18.86	18.94	18.91		
1.4	QPSK	6	0	18.90	18.92	18.87	20	1
1.4	16QAM	1	0	18.90	18.96	18.92	20	1
1.4	16QAM	1	2	18.87	18.92	18.88		
1.4	16QAM	1	5	18.79	18.89	18.90		
1.4	16QAM	3	0	18.79	18.93	18.89		
1.4	16QAM	3	1	18.89	18.95	18.91		
1.4	16QAM	3	2	18.84	18.90	18.90		
1.4	16QAM	6	0	18.83	18.88	18.90	20	2



<LTE Band 25>

BW [MHz]	Modulation	RB Size	RB Offset	Power Low Ch. / Freq.	Power Middle Ch. / Freq.	Power High Ch. / Freq.	Tune up Limit (dBm)	MPR (dB)
Channel				26140	26340	26590		
Frequency (MHz)				1860	1880	1905		
20	QPSK	1	0	18.79	18.91	18.69	20	0
20	QPSK	1	49	18.72	18.69	18.63		
20	QPSK	1	99	18.64	18.45	18.43		
20	QPSK	50	0	18.63	18.64	18.55	20	1
20	QPSK	50	24	18.53	18.49	18.48		
20	QPSK	50	49	18.50	18.40	18.52		
20	QPSK	100	0	18.52	18.59	18.55		
20	16QAM	1	0	18.75	18.89	18.68	20	1
20	16QAM	1	49	18.70	18.73	18.62		
20	16QAM	1	99	18.66	18.44	18.61		
20	16QAM	50	0	18.59	18.54	18.38	20	2
20	16QAM	50	24	18.51	18.52	18.51		
20	16QAM	50	49	18.49	18.38	18.58		
20	16QAM	100	0	18.53	18.51	18.51		
Channel				26115	26340	26615	Tune up Limit (dBm)	MPR (dB)
Frequency (MHz)				1857.5	1880	1907.5		
15	QPSK	1	0	18.83	18.84	18.85	20	0
15	QPSK	1	37	18.79	18.82	18.84		
15	QPSK	1	74	18.75	18.49	18.69		
15	QPSK	36	0	18.65	18.63	18.58	20	1
15	QPSK	36	18	18.73	18.57	18.73		
15	QPSK	36	37	18.60	18.45	18.82		
15	QPSK	75	0	18.53	18.55	18.70		
15	16QAM	1	0	18.77	18.74	18.74	20	1
15	16QAM	1	37	18.68	18.75	18.79		
15	16QAM	1	74	18.64	18.44	18.84		
15	16QAM	36	0	18.61	18.59	18.51	20	2
15	16QAM	36	18	18.69	18.53	18.64		
15	16QAM	36	37	18.52	18.44	18.78		
15	16QAM	75	0	18.52	18.44	18.73		
Channel				26090	26340	26640	Tune up Limit (dBm)	MPR (dB)
Frequency (MHz)				1855	1880	1910		
10	QPSK	1	0	18.74	18.75	18.81	20	0
10	QPSK	1	24	18.71	18.73	18.80		
10	QPSK	1	49	18.74	18.54	18.77		
10	QPSK	25	0	18.63	18.66	18.75	20	1
10	QPSK	25	12	18.61	18.54	18.78		
10	QPSK	25	24	18.72	18.55	18.73		
10	QPSK	50	0	18.59	18.50	18.69		
10	16QAM	1	0	18.73	18.76	18.75	20	1
10	16QAM	1	24	18.77	18.71	18.63		
10	16QAM	1	49	18.77	18.52	18.69		
10	16QAM	25	0	18.53	18.57	18.66	20	2
10	16QAM	25	12	18.57	18.54	18.71		
10	16QAM	25	24	18.61	18.50	18.66		
10	16QAM	50	0	18.52	18.48	18.66		



Channel				26065	26340	26665	Tune up Limit (dBm)	MPR (dB)
Frequency (MHz)				1852.5	1880	1912.5		
5	QPSK	1	0	18.74	18.74	18.86	20	0
5	QPSK	1	12	18.69	18.68	18.79		
5	QPSK	1	24	18.71	18.66	18.85		
5	QPSK	12	0	18.72	18.70	18.84	20	1
5	QPSK	12	6	18.64	18.68	18.79		
5	QPSK	12	11	18.67	18.63	18.79		
5	QPSK	25	0	18.53	18.57	18.75	20	1
5	16QAM	1	0	18.68	18.73	18.88		
5	16QAM	1	12	18.70	18.71	18.84		
5	16QAM	1	24	18.72	18.65	18.81	20	2
5	16QAM	12	0	18.75	18.68	18.79		
5	16QAM	12	6	18.65	18.67	18.84		
5	16QAM	12	11	18.63	18.68	18.84	20	2
5	16QAM	25	0	18.53	18.54	18.73		
5	16QAM	25	0	18.53	18.54	18.73		
Channel				26055	26340	26675	Tune up Limit (dBm)	MPR (dB)
Frequency (MHz)				1851.5	1880	1913.5		
3	QPSK	1	0	18.71	18.71	18.91	20	0
3	QPSK	1	7	18.69	18.71	18.90		
3	QPSK	1	14	18.67	18.72	18.82		
3	QPSK	8	0	18.75	18.70	18.83	20	1
3	QPSK	8	4	18.74	18.69	18.83		
3	QPSK	8	7	18.78	18.69	18.86		
3	QPSK	15	0	18.71	18.64	18.90	20	1
3	16QAM	1	0	18.72	18.77	18.85		
3	16QAM	1	7	18.74	18.77	18.82		
3	16QAM	1	14	18.70	18.71	18.84	20	2
3	16QAM	8	0	18.65	18.60	18.84		
3	16QAM	8	4	18.63	18.61	18.84		
3	16QAM	8	7	18.64	18.59	18.80	20	2
3	16QAM	8	7	18.64	18.59	18.80		
3	16QAM	15	0	18.69	18.65	18.76		
3	16QAM	15	0	18.69	18.65	18.76	20	2
3	16QAM	15	0	18.69	18.65	18.76		
3	16QAM	15	0	18.69	18.65	18.76		
Channel				26047	26340	26683	Tune up Limit (dBm)	MPR (dB)
Frequency (MHz)				1850.7	1880	1914.3		
1.4	QPSK	1	0	18.76	18.77	18.85	20	0
1.4	QPSK	1	2	18.77	18.77	18.91		
1.4	QPSK	1	5	18.77	18.77	18.90		
1.4	QPSK	3	0	18.80	18.77	18.90	20	1
1.4	QPSK	3	1	18.75	18.73	18.82		
1.4	QPSK	3	2	18.72	18.78	18.81		
1.4	QPSK	6	0	18.71	18.73	18.90	20	1
1.4	16QAM	1	0	18.69	18.67	18.80	20	1
1.4	16QAM	1	2	18.71	18.66	18.85		
1.4	16QAM	1	5	18.77	18.69	18.79		
1.4	16QAM	3	0	18.78	18.76	18.77	20	1
1.4	16QAM	3	1	18.76	18.75	18.78		
1.4	16QAM	3	2	18.78	18.70	18.82		
1.4	16QAM	6	0	18.76	18.76	18.75	20	2

14. Antenna Location

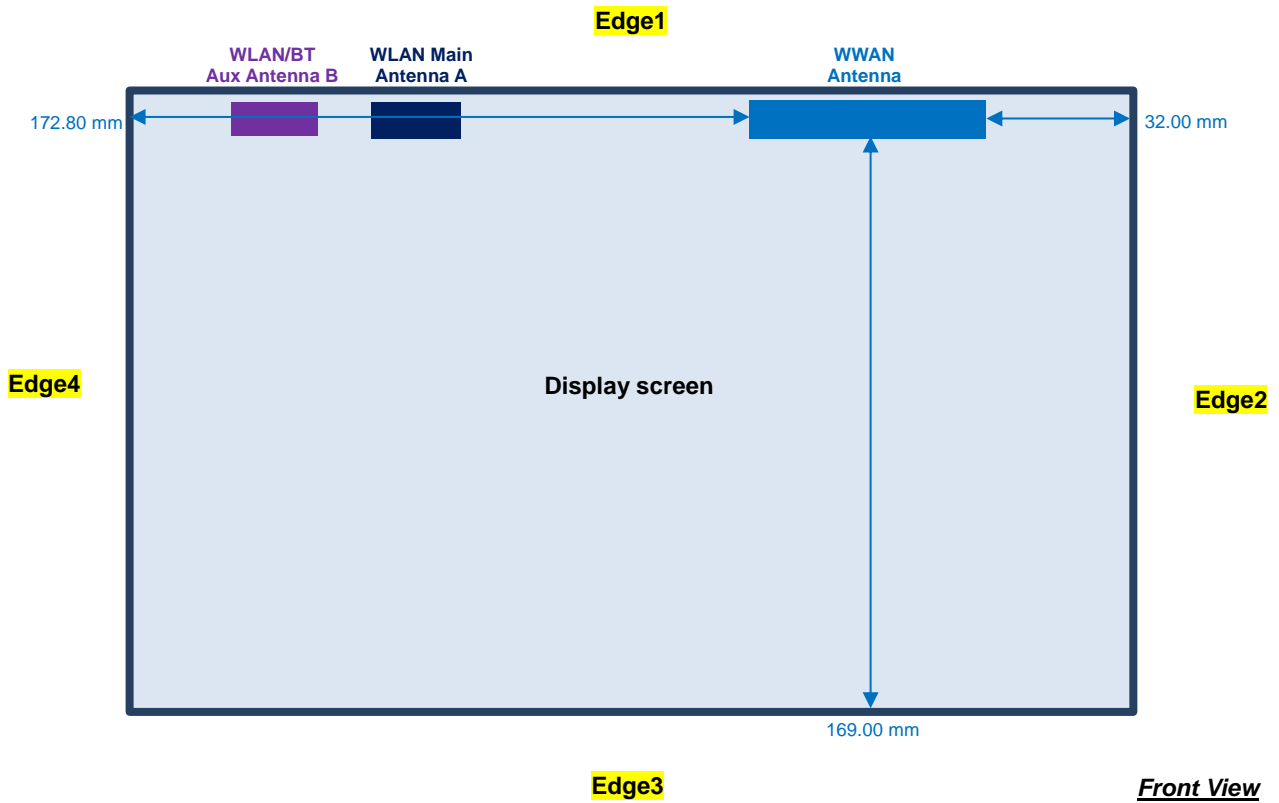



<SAR test exclusion table>

General Note:

1. The below table, when the distance is < 50 mm exclusion threshold is "Ratio", when the distance is > 50 mm exclusion threshold is "mW"
2. Maximum power is the source-based time-average power and represents the maximum RF output power among production units
3. Per KDB 447498 D01v05r02, for larger devices, the test separation distance of adjacent edge configuration is determined by the closest separation between the antenna and the user.
4. Per KDB 447498 D01v05r02, standalone SAR test exclusion threshold is applied; If the test separation distance is < 5mm, 5mm is used to determine SAR exclusion threshold.
5. Per KDB 447498 D01v05r02, the 1-g and 10-g SAR test exclusion thresholds for 100 MHz to 6 GHz at *test separation distances* ≤ 50 mm are determined by:
 - [(max. power of channel, including tune-up tolerance, mW)/(min. test separation distance, mm)] · [√f(GHz)] ≤ 3.0 for 1-g SAR and ≤ 7.5 for 10-g extremity SAR
 - f(GHz) is the RF channel transmit frequency in GHz
 - Power and distance are rounded to the nearest mW and mm before calculation
 - The result is rounded to one decimal place for comparison
6. Per KDB 447498 D01v05r02, at 100 MHz to 6 GHz and for *test separation distances* > 50 mm, the SAR test exclusion threshold is determined according to the following
 - a) [Threshold at 50 mm in step 1) + (test separation distance - 50 mm)·(f(MHz)/150)] mW, at 100 MHz to 1500 MHz
 - b) [Threshold at 50 mm in step 1) + (test separation distance - 50 mm)·10] mW at > 1500 MHz and ≤ 6 GHz

Exposure Position	Wireless Interface	GPRS 850 Class 10	GPRS 1900 Class 10	WCDMA Band V	WCDMA Band IV	WCDMA Band II	CDMA BC10	CDMA BC0	CDMA BC1	LTE Band 17	LTE Band 13	LTE Band 5	LTE Band 4	LTE Band 2	LTE Band 25
	Calculated Frequency	848MHz	1909MHz	846MHz	1750MHz	1907MHz	846MHz	848MHz	1907MHz	713MHz	784MHz	848MHz	1754MHz	1909MHz	1914MHz
	Maximum power (dBm)	27	24	24	24	24	24.5	24.5	24.5	24	24	24	24	24	24
	Maximum rated power(mW)	501.0	251.0	251.0	251.0	251.0	282.0	282.0	282.0	251.0	251.0	251.0	251.0	251.0	251.0
Bottom Face	Separation distance(mm)	5													
	exclusion threshold	92.3	69.4	46.2	66.4	69.3	51.9	51.9	77.9	42.4	44.5	46.2	66.5	69.4	69.5
	Testing required?	Yes	Yes	Yes	Yes	Yes	Yes	Yes	Yes	Yes	Yes	Yes	Yes	Yes	Yes
Edge 1	Separation distance(mm)	5.00													
	exclusion threshold	92.3	69.4	46.2	66.4	69.3	51.9	51.9	77.9	42.4	44.5	46.2	66.5	69.4	69.5
	Testing required?	Yes	Yes	Yes	Yes	Yes	Yes	Yes	Yes	Yes	Yes	Yes	Yes	Yes	Yes
Edge 2	Separation distance(mm)	32.00													
	exclusion threshold	14.4	10.8	7.2	10.4	10.8	8.1	8.1	12.2	6.6	7.0	7.2	10.4	10.8	10.9
	Testing required?	Yes	Yes	Yes	Yes	Yes	Yes	Yes	Yes	Yes	Yes	Yes	Yes	Yes	Yes
Edge 3	Separation distance(mm)	169.00													
	exclusion threshold	836.0	1299.0	834.0	1303.0	1299.0	834.0	836.0	1299.0	743.0	791.0	836.0	1303.0	1299.0	1298.0
	Testing required?	No	No	No	No	No	No	No	No	No	No	No	No	No	No
Edge 4	Separation distance(mm)	172.80													
	exclusion threshold	857.0	1337.0	856.0	1341.0	1337.0	856.0	857.0	1337.0	761.0	811.0	857.0	1341.0	1337.0	1336.0
	Testing required?	No	No	No	No	No	No	No	No	No	No	No	No	No	No



15. SAR Test Results

General Note:

1. Per KDB 447498 D01v05r02, the reported SAR is the measured SAR value adjusted for maximum tune-up tolerance.
 - a. Tune-up scaling Factor = tune-up limit power (mW) / EUT RF power (mW), where tune-up limit is the maximum rated power among all production units.
 - b. For WWAN: Reported SAR(W/kg)= Measured SAR(W/kg)*Tune-up Scaling Factor
2. Per KDB 447498 D01v05r02, for each exposure position, testing of other required channels within the operating mode of a frequency band is not required when the *reported* 1-g or 10-g SAR for the mid-band or highest output power channel is:
 - ≤ 0.8 W/kg or 2.0 W/kg, for 1-g or 10-g respectively, when the transmission band is ≤ 100 MHz
 - ≤ 0.6 W/kg or 1.5 W/kg, for 1-g or 10-g respectively, when the transmission band is between 100 MHz and 200 MHz
 - ≤ 0.4 W/kg or 1.0 W/kg, for 1-g or 10-g respectively, when the transmission band is ≥ 200 MHz
3. For the exposure positions that proximity sensor power reduction is applied for SAR compliance, additional SAR testing with EUT transmitting full power in normal mode was performed; 1.3cm for bottom face, 1.5cm for edge1, 1.5cm for curved surface of Edge 1.
4. When the minimum distance between antenna and device edge along the curve is less than bottom face and surface edge, the curved SAR is necessary, more detail information which can be referred to setup photo.
5. For SAR testing of the curved region of the device, the device was placed directly against the phantom at the point where the distance between the antenna and device exterior is a minimum.
6. Per KDB 941225 D01v03, for Body SAR test reduction for GPRS and EDGE modes is determined by the source-based time-averaged output power including tune-up tolerance, for modes with the same specified maximum output power and tolerance, the higher number time-slot configuration should be tested, therefore, the GPRS 2Tx slots modes was selected when EUT operating without power back-off, the GPRS 2Tx slots modes was selected when EUT operating with power back-off, according to the highest source-based time-averaged output power.
7. Per KDB 941225 D01v03, RMC 12.2kbps setting is used to evaluate SAR. If the maximum output power and tune-up tolerance specified for production units in HSDPA / HSUPA / DC-HSDPA is $\leq \frac{1}{4}$ dB higher than RMC 12.2Kbps or when the highest reported SAR of the RMC12.2Kbps is scaled by the ratio of specified maximum output power and tune-up tolerance of HSDPA / HSUPA / DC-HSDPA to RMC12.2Kbps and the adjusted SAR is ≤ 1.2 W/kg, SAR measurement is not required for HSDPA / HSUPA / DC-HSDPA.
8. Per KDB 941225 D01v03, when in Body SAR testing, the EUT is treated as data device and SAR is tested with Ev-Do Rev 0 (RTAP 153.6kbps) as the primary mode.
9. Per KDB 941225 D05v02r03, start with the largest channel bandwidth and measure SAR for QPSK with 1 RB allocation, using the RB offset and required test channel combination with the highest maximum output power for RB offsets at the upper edge, middle and lower edge of each required test channel.
10. Per KDB 941225 D05v02r03, 50% RB allocation for QPSK SAR testing follows 1RB QPSK allocation procedure.
11. Per KDB 941225 D05v02r03, For QPSK with 100% RB allocation, SAR is not required when the highest maximum output power for 100 % RB allocation is less than the highest maximum output power in 50% and 1 RB allocations and the highest reported SAR for 1 RB and 50% RB allocation are ≤ 0.8 W/kg. Otherwise, SAR is measured for the highest output power channel; and if the reported SAR is > 1.45 W/kg, the remaining required test channels must also be tested.
12. Per KDB 941225 D05v02r03, 16QAM output power for each RB allocation configuration is $> \text{not } \frac{1}{2}$ dB higher than the same configuration in QPSK and the reported SAR for the QPSK configuration is ≤ 1.45 W/kg; Per KDB 941225 D05v02r03, 16QAM SAR testing is not required.
13. Per KDB 941225 D05v02r03, Smaller bandwidth output power for each RB allocation configuration is $> \text{not } \frac{1}{2}$ dB higher than the same configuration in the largest supported bandwidth, and the reported SAR for the largest supported bandwidth is ≤ 1.45 W/kg; Per KDB 941225 D05v02r03, smaller bandwidth SAR testing is not required.



15.1 Body SAR

<GSM SAR>

Plot No.	Band	Mode	Test Position	Gap (cm)	Power Reduction	Ch.	Freq. (MHz)	Average Power (dBm)	Tune-Up Limit (dBm)	Tune-up Scaling Factor	Power Drift (dB)	Measured 1g SAR (W/kg)	Reported 1g SAR (W/kg)
	GSM850	GPRS (2 Tx slots)	Bottom Face	1.3cm	OFF	189	836.4	31.96	33.00	1.271	-0.02	0.434	0.551
	GSM850	GPRS (2 Tx slots)	Edge 1	1.5cm	OFF	189	836.4	31.96	33.00	1.271	-0.06	0.386	0.490
	GSM850	GPRS (2 Tx slots)	Edge 2	0cm	OFF	189	836.4	31.96	33.00	1.271	0.08	0.106	0.135
	GSM850	GPRS (2 Tx slots)	Curved surface of Edge 1	1.5cm	OFF	189	836.4	31.96	33.00	1.271	0.02	0.506	0.643
	GSM850	GPRS (2 Tx slots)	Bottom Face	0cm	ON	189	836.4	26.98	27.00	1.005	0.07	0.595	0.598
	GSM850	GPRS (2 Tx slots)	Edge 1	0cm	ON	189	836.4	26.98	27.00	1.005	-0.16	0.758	0.761
1	GSM850	GPRS (2 Tx slots)	Curved surface of Edge 1	0cm	ON	189	836.4	26.98	27.00	1.005	-0.17	0.901	0.905
	GSM850	GPRS (2 Tx slots)	Curved surface of Edge 1	0cm	ON	128	824.2	26.91	27.00	1.021	-0.1	0.871	0.889
	GSM850	GPRS (2 Tx slots)	Curved surface of Edge 1	0cm	ON	251	848.8	26.94	27.00	1.014	-0.15	0.883	0.895
	GSM1900	GPRS (2 Tx slots)	Bottom Face	1.3cm	OFF	810	1909.8	29.18	30.00	1.208	0.04	0.272	0.329
	GSM1900	GPRS (2 Tx slots)	Edge 1	1.5cm	OFF	810	1909.8	29.18	30.00	1.208	0.01	0.323	0.390
	GSM1900	GPRS (2 Tx slots)	Edge 2	0cm	OFF	810	1909.8	29.18	30.00	1.208	-0.04	0.233	0.281
	GSM1900	GPRS (2 Tx slots)	Curved surface of Edge 1	1.5cm	OFF	810	1909.8	29.18	30.00	1.208	-0.05	0.346	0.418
	GSM1900	GPRS (2 Tx slots)	Bottom Face	0cm	ON	810	1909.8	25.96	26.00	1.009	-0.13	0.178	0.180
	GSM1900	GPRS (2 Tx slots)	Edge 1	0cm	ON	810	1909.8	25.96	26.00	1.009	-0.06	0.965	0.974
2	GSM1900	GPRS (2 Tx slots)	Edge 1	0cm	ON	512	1850.2	25.85	26.00	1.035	-0.15	1.040	1.077
	GSM1900	GPRS (2 Tx slots)	Edge 1	0cm	ON	661	1880	25.83	26.00	1.040	-0.04	1.010	1.050
	GSM1900	GPRS (2 Tx slots)	Curved surface of Edge 1	0cm	ON	810	1909.8	25.96	26.00	1.009	0.03	0.801	0.808
	GSM1900	GPRS (2 Tx slots)	Curved surface of Edge 1	0cm	ON	512	1850.2	25.85	26.00	1.035	-0.14	0.945	0.978
	GSM1900	GPRS (2 Tx slots)	Curved surface of Edge 1	0cm	ON	661	1880	25.83	26.00	1.040	0.04	0.859	0.893

<WCDMA SAR>

Plot No.	Band	Mode	Test Position	Gap (cm)	Power Reduction	Ch.	Freq. (MHz)	Average Power (dBm)	Tune-Up Limit (dBm)	Tune-up Scaling Factor	Power Drift (dB)	Measured 1g SAR (W/kg)	Reported 1g SAR (W/kg)
	WCDMA V	RMC12.2Kbps	Bottom Face	1.3cm	OFF	4182	836.4	22.48	24.00	1.419	-0.02	0.251	0.356
	WCDMA V	RMC12.2Kbps	Edge 1	1.5cm	OFF	4182	836.4	22.48	24.00	1.419	-0.03	0.221	0.314
	WCDMA V	RMC12.2Kbps	Edge 2	0cm	OFF	4182	836.4	22.48	24.00	1.419	-0.1	0.064	0.091
	WCDMA V	RMC12.2Kbps	Curved surface of Edge 1	1.5cm	OFF	4182	836.4	22.48	24.00	1.419	-0.01	0.305	0.433
	WCDMA V	RMC12.2Kbps	Bottom Face	0cm	ON	4182	836.4	19.71	20.00	1.069	-0.16	0.314	0.336
	WCDMA V	RMC12.2Kbps	Edge 1	0cm	ON	4182	836.4	19.71	20.00	1.069	-0.11	0.584	0.624
	WCDMA V	RMC12.2Kbps	Curved surface of Edge 1	0cm	ON	4182	836.4	19.71	20.00	1.069	-0.06	0.700	0.748
	WCDMA V	RMC12.2Kbps	Curved surface of Edge 1	0cm	ON	4132	826.4	19.67	20.00	1.079	0.07	0.799	0.862
3	WCDMA V	RMC12.2Kbps	Curved surface of Edge 1	0cm	ON	4233	846.6	19.57	20.00	1.104	-0.04	0.815	0.900
	WCDMA IV	RMC12.2Kbps	Bottom Face	1.3cm	OFF	1312	1712.4	22.41	24.00	1.442	-0.09	0.457	0.659
	WCDMA IV	RMC12.2Kbps	Edge 1	1.5cm	OFF	1312	1712.4	22.41	24.00	1.442	-0.08	0.514	0.741
	WCDMA IV	RMC12.2Kbps	Edge 2	0cm	OFF	1312	1712.4	22.41	24.00	1.442	0.07	0.274	0.395
	WCDMA IV	RMC12.2Kbps	Curved surface of Edge 1	1.5cm	OFF	1312	1712.4	22.41	24.00	1.442	0.06	0.540	0.779
	WCDMA IV	RMC12.2Kbps	Bottom Face	0cm	ON	1312	1712.4	16.55	18.00	1.396	-0.19	0.229	0.320
4	WCDMA IV	RMC12.2Kbps	Edge 1	0cm	ON	1312	1712.4	16.55	18.00	1.396	0.01	0.651	0.909
	WCDMA IV	RMC12.2Kbps	Edge 1	0cm	ON	1413	1732.6	16.49	18.00	1.416	-0.15	0.460	0.651
	WCDMA IV	RMC12.2Kbps	Edge 1	0cm	ON	1513	1752.6	16.50	18.00	1.413	0.18	0.560	0.791
	WCDMA IV	RMC12.2Kbps	Curved surface of Edge 1	0cm	ON	1312	1712.4	16.55	18.00	1.396	-0.02	0.559	0.781
	WCDMA II	RMC12.2Kbps	Bottom Face	1.3cm	OFF	9538	1907.6	22.62	24.00	1.374	-0.03	0.280	0.385
	WCDMA II	RMC12.2Kbps	Edge 1	1.5cm	OFF	9538	1907.6	22.62	24.00	1.374	-0.07	0.333	0.458
	WCDMA II	RMC12.2Kbps	Edge 2	0cm	OFF	9538	1907.6	22.62	24.00	1.374	-0.06	0.233	0.320
	WCDMA II	RMC12.2Kbps	Curved surface of Edge 1	1.5cm	OFF	9538	1907.6	22.62	24.00	1.374	-0.07	0.318	0.437
	WCDMA II	RMC12.2Kbps	Bottom Face	0cm	ON	9538	1907.6	18.57	20.00	1.390	-0.05	0.279	0.388
	WCDMA II	RMC12.2Kbps	Edge 1	0cm	ON	9538	1907.6	18.57	20.00	1.390	-0.07	0.612	0.851
5	WCDMA II	RMC12.2Kbps	Edge 1	0cm	ON	9262	1852.4	18.23	20.00	1.503	-0.01	0.660	0.992
	WCDMA II	RMC12.2Kbps	Edge 1	0cm	ON	9400	1880	18.40	20.00	1.445	-0.02	0.607	0.877
	WCDMA II	RMC12.2Kbps	Curved surface of Edge 1	0cm	ON	9538	1907.6	18.57	20.00	1.390	-0.09	0.476	0.662



<CDMA SAR>

Plot No.	Band	Mode	Test Position	Gap (cm)	Power Reduction	Ch.	Freq. (MHz)	Average Power (dBm)	Tune-Up Limit (dBm)	Tune-up Scaling Factor	Power Drift (dB)	Measured 1g SAR (W/kg)	Reported 1g SAR (W/kg)
	CDMA BC10	RTAP 153.6Kbps	Bottom Face	1.3cm	OFF	580	820.5	23.54	24.50	1.247	-0.05	0.305	0.380
	CDMA BC10	RTAP 153.6Kbps	Edge 1	1.5cm	OFF	580	820.5	23.54	24.50	1.247	-0.02	0.279	0.348
	CDMA BC10	RTAP 153.6Kbps	Edge 2	0cm	OFF	580	820.5	23.54	24.50	1.247	-0.02	0.110	0.137
	CDMA BC10	RTAP 153.6Kbps	Curved surface of Edge 1	1.5cm	OFF	580	820.5	23.54	24.50	1.247	0.02	0.345	0.430
	CDMA BC10	RTAP 153.6Kbps	Bottom Face	0cm	ON	580	820.5	19.78	20.50	1.180	0.04	0.629	0.742
	CDMA BC10	RTAP 153.6Kbps	Edge 1	0cm	ON	580	820.5	19.78	20.50	1.180	-0.02	0.671	0.792
6	CDMA BC10	RTAP 153.6Kbps	Curved surface of Edge 1	0cm	ON	580	820.5	19.78	20.50	1.180	-0.02	0.723	0.853
	CDMA BC0	RTAP 153.6Kbps	Bottom Face	1.3cm	OFF	384	836.52	23.55	24.50	1.245	-0.15	0.342	0.426
	CDMA BC0	RTAP 153.6Kbps	Edge 1	1.5cm	OFF	384	836.52	23.55	24.50	1.245	-0.17	0.345	0.429
	CDMA BC0	RTAP 153.6Kbps	Edge 2	0cm	OFF	384	836.52	23.55	24.50	1.245	0.06	0.094	0.117
	CDMA BC0	RTAP 153.6Kbps	Curved surface of Edge 1	1.5cm	OFF	384	836.52	23.55	24.50	1.245	-0.11	0.420	0.523
	CDMA BC0	RTAP 153.6Kbps	Bottom Face	0cm	ON	384	836.52	19.74	20.50	1.191	0.01	0.705	0.840
	CDMA BC0	RTAP 153.6Kbps	Bottom Face	0cm	ON	1013	824.7	19.58	20.50	1.236	0.03	0.659	0.814
	CDMA BC0	RTAP 153.6Kbps	Bottom Face	0cm	ON	777	848.31	19.48	20.50	1.265	0.01	0.691	0.874
	CDMA BC0	RTAP 153.6Kbps	Edge 1	0cm	ON	384	836.52	19.74	20.50	1.191	-0.09	0.795	0.947
	CDMA BC0	RTAP 153.6Kbps	Edge 1	0cm	ON	1013	824.7	19.58	20.50	1.236	-0.17	0.716	0.885
	CDMA BC0	RTAP 153.6Kbps	Edge 1	0cm	ON	777	848.31	19.48	20.50	1.265	-0.09	0.766	0.969
7	CDMA BC0	RTAP 153.6Kbps	Curved surface of Edge 1	0cm	ON	384	836.52	19.74	20.50	1.191	-0.14	0.876	1.044
	CDMA BC0	RTAP 153.6Kbps	Curved surface of Edge 1	0cm	ON	1013	824.7	19.58	20.50	1.236	0.01	0.736	0.910
	CDMA BC0	RTAP 153.6Kbps	Curved surface of Edge 1	0cm	ON	777	848.31	19.48	20.50	1.265	-0.04	0.823	1.041
	CDMA BC1	RTAP 153.6Kbps	Bottom Face	1.3cm	OFF	25	1851.25	23.58	24.50	1.236	0.04	0.438	0.541
	CDMA BC1	RTAP 153.6Kbps	Edge 1	1.5cm	OFF	25	1851.25	23.58	24.50	1.236	-0.03	0.538	0.665
	CDMA BC1	RTAP 153.6Kbps	Edge 2	0cm	OFF	25	1851.25	23.58	24.50	1.236	-0.03	0.324	0.400
	CDMA BC1	RTAP 153.6Kbps	Curved surface of Edge 1	1.5cm	OFF	25	1851.25	23.58	24.50	1.236	-0.05	0.562	0.695
	CDMA BC1	RTAP 153.6Kbps	Bottom Face	0cm	ON	25	1851.25	18.79	19.50	1.178	-0.05	0.500	0.589
8	CDMA BC1	RTAP 153.6Kbps	Edge 1	0cm	ON	25	1851.25	18.79	19.50	1.178	-0.18	0.742	0.874
	CDMA BC1	RTAP 153.6Kbps	Edge 1	0cm	ON	600	1880	18.63	19.50	1.222	-0.01	0.678	0.828
	CDMA BC1	RTAP 153.6Kbps	Edge 1	0cm	ON	1175	1908.75	18.68	19.50	1.208	0.01	0.644	0.778
	CDMA BC1	RTAP 153.6Kbps	Curved surface of Edge 1	0cm	ON	25	1851.25	18.79	19.50	1.178	-0.01	0.658	0.775

<LTE SAR>

Plot No.	Band	BW (MHz)	Modulation	RB Size	RB offset	Test Position	Gap (cm)	Power Reduction	Ch.	Freq. (MHz)	Average Power (dBm)	Tune-Up Limit (dBm)	Tune-up Scaling Factor	Power Drift (dB)	Measured 1g SAR (W/kg)	Reported 1g SAR (W/kg)
	LTE Band 17	10M	QPSK	1RB	0offset	Bottom Face	1.3cm	OFF	23790	710	22.62	24.00	1.374	0.05	0.259	0.356
	LTE Band 17	10M	QPSK	25RB	0offset	Bottom Face	1.3cm	OFF	23790	710	21.72	23.00	1.343	0.07	0.207	0.278
	LTE Band 17	10M	QPSK	1RB	0offset	Edge 1	1.5cm	OFF	23790	710	22.62	24.00	1.374	0	0.125	0.172
	LTE Band 17	10M	QPSK	25RB	0offset	Edge 1	1.5cm	OFF	23790	710	21.72	23.00	1.343	-0.01	0.102	0.137
	LTE Band 17	10M	QPSK	1RB	0offset	Edge 2	0cm	OFF	23790	710	22.62	24.00	1.374	0	0.132	0.181
	LTE Band 17	10M	QPSK	25RB	0offset	Edge 2	0cm	OFF	23790	710	21.72	23.00	1.343	0.09	0.111	0.149
	LTE Band 17	10M	QPSK	1RB	0offset	Curved surface of Edge 1	1.5cm	OFF	23790	710	22.62	24.00	1.374	0.02	0.206	0.283
	LTE Band 17	10M	QPSK	25RB	0offset	Curved surface of Edge 1	1.5cm	OFF	23790	710	21.72	23.00	1.343	0.07	0.166	0.223
	LTE Band 17	10M	QPSK	1RB	0offset	Bottom Face	0cm	ON	23790	710	21.60	23.00	1.380	-0.03	0.494	0.682
	LTE Band 17	10M	QPSK	25RB	0offset	Bottom Face	0cm	ON	23790	710	21.53	23.00	1.403	0	0.485	0.680
	LTE Band 17	10M	QPSK	1RB	0offset	Edge 1	0cm	ON	23790	710	21.60	23.00	1.380	-0.11	0.421	0.581
	LTE Band 17	10M	QPSK	25RB	0offset	Edge 1	0cm	ON	23790	710	21.53	23.00	1.403	-0.08	0.410	0.575
9	LTE Band 17	10M	QPSK	1RB	0offset	Curved surface of Edge 1	0cm	ON	23790	710	21.60	23.00	1.380	-0.07	0.553	0.763
	LTE Band 17	10M	QPSK	25RB	0offset	Curved surface of Edge 1	0cm	ON	23790	710	21.53	23.00	1.403	-0.03	0.542	0.760



Plot No.	Band	BW (MHz)	Modulation	RB Size	RB offset	Test Position	Gap (cm)	Power Reduction	Ch.	Freq. (MHz)	Average Power (dBm)	Tune-Up Limit (dBm)	Tune-up Scaling Factor	Power Drift (dB)	Measured 1g SAR (W/kg)	Reported 1g SAR (W/kg)
	LTE Band 13	10M	QPSK	1RB	0offset	Bottom Face	1.3cm	OFF	23230	782	22.83	24.00	1.309	0.04	0.238	0.312
	LTE Band 13	10M	QPSK	25RB	0offset	Bottom Face	1.3cm	OFF	23230	782	21.80	23.00	1.318	0.09	0.188	0.248
	LTE Band 13	10M	QPSK	1RB	0offset	Edge 1	1.5cm	OFF	23230	782	22.83	24.00	1.309	0.01	0.102	0.134
	LTE Band 13	10M	QPSK	25RB	0offset	Edge 1	1.5cm	OFF	23230	782	21.80	23.00	1.318	-0.07	0.092	0.121
	LTE Band 13	10M	QPSK	1RB	0offset	Edge 2	0cm	OFF	23230	782	22.83	24.00	1.309	0.19	0.065	0.085
	LTE Band 13	10M	QPSK	25RB	0offset	Edge 2	0cm	OFF	23230	782	21.80	23.00	1.318	0.19	0.052	0.069
	LTE Band 13	10M	QPSK	1RB	0offset	Curved surface of Edge 1	1.5cm	OFF	23230	782	22.83	24.00	1.309	0.03	0.182	0.238
	LTE Band 13	10M	QPSK	25RB	0offset	Curved surface of Edge 1	1.5cm	OFF	23230	782	21.80	23.00	1.318	-0.07	0.154	0.203
	LTE Band 13	10M	QPSK	1RB	0offset	Bottom Face	0cm	ON	23230	782	20.45	21.00	1.135	0.05	0.409	0.464
	LTE Band 13	10M	QPSK	25RB	0offset	Bottom Face	0cm	ON	23230	782	20.42	21.00	1.143	0.07	0.383	0.438
	LTE Band 13	10M	QPSK	1RB	0offset	Edge 1	0cm	ON	23230	782	20.45	21.00	1.135	-0.16	0.415	0.471
	LTE Band 13	10M	QPSK	25RB	0offset	Edge 1	0cm	ON	23230	782	20.42	21.00	1.143	-0.15	0.405	0.463
10	LTE Band 13	10M	QPSK	1RB	0offset	Curved surface of Edge 1	0cm	ON	23230	782	20.45	21.00	1.135	0.01	0.552	0.627
	LTE Band 13	10M	QPSK	25RB	0offset	Curved surface of Edge 1	0cm	ON	23230	782	20.42	21.00	1.143	-0.08	0.545	0.623
	LTE Band 5	10M	QPSK	1RB	0offset	Bottom Face	1.3cm	OFF	20525	836.5	22.81	24.00	1.315	-0.12	0.290	0.381
	LTE Band 5	10M	QPSK	25RB	0offset	Bottom Face	1.3cm	OFF	20525	836.5	21.77	23.00	1.327	-0.05	0.254	0.337
	LTE Band 5	10M	QPSK	1RB	0offset	Edge 1	1.5cm	OFF	20525	836.5	22.81	24.00	1.315	0.05	0.252	0.331
	LTE Band 5	10M	QPSK	25RB	0offset	Edge 1	1.5cm	OFF	20525	836.5	21.77	23.00	1.327	-0.04	0.208	0.276
	LTE Band 5	10M	QPSK	1RB	0offset	Edge 2	0cm	OFF	20525	836.5	22.81	24.00	1.315	0.05	0.071	0.093
	LTE Band 5	10M	QPSK	25RB	0offset	Edge 2	0cm	OFF	20525	836.5	21.77	23.00	1.327	-0.02	0.058	0.077
	LTE Band 5	10M	QPSK	1RB	0offset	Curved surface of Edge 1	1.5cm	OFF	20525	836.5	22.81	24.00	1.315	0.04	0.294	0.387
	LTE Band 5	10M	QPSK	25RB	0offset	Curved surface of Edge 1	1.5cm	OFF	20525	836.5	21.77	23.00	1.327	-0.02	0.236	0.313
	LTE Band 5	10M	QPSK	1RB	0offset	Bottom Face	0cm	ON	20525	836.5	18.71	19.00	1.069	-0.03	0.582	0.622
	LTE Band 5	10M	QPSK	25RB	0offset	Bottom Face	0cm	ON	20525	836.5	18.58	19.00	1.102	-0.07	0.560	0.617
	LTE Band 5	10M	QPSK	1RB	0offset	Edge 1	0cm	ON	20525	836.5	18.71	19.00	1.069	-0.09	0.692	0.740
	LTE Band 5	10M	QPSK	25RB	0offset	Edge 1	0cm	ON	20525	836.5	18.58	19.00	1.102	-0.02	0.678	0.747
	LTE Band 5	10M	QPSK	1RB	0offset	Curved surface of Edge 1	0cm	ON	20525	836.5	18.71	19.00	1.069	-0.04	0.867	0.927
	LTE Band 5	10M	QPSK	1RB	0offset	Curved surface of Edge 1	0cm	ON	20450	829	18.58	19.00	1.102	0.03	0.800	0.881
11	LTE Band 5	10M	QPSK	1RB	0offset	Curved surface of Edge 1	0cm	ON	20600	844	18.68	19.00	1.076	0.05	0.917	0.987
	LTE Band 5	10M	QPSK	25RB	0offset	Curved surface of Edge 1	0cm	ON	20525	836.5	18.58	19.00	1.102	0	0.877	0.966
	LTE Band 5	10M	QPSK	25RB	0offset	Curved surface of Edge 1	0cm	ON	20450	829	18.47	19.00	1.130	0.01	0.792	0.895
	LTE Band 5	10M	QPSK	25RB	0offset	Curved surface of Edge 1	0cm	ON	20600	844	18.57	19.00	1.104	0	0.890	0.983
	LTE Band 5	10M	QPSK	50RB	0offset	Curved surface of Edge 1	0cm	ON	20525	836.5	18.53	19.00	1.114	-0.03	0.871	0.971



Plot No.	Band	BW (MHz)	Modulation	RB Size	RB offset	Test Position	Gap (cm)	Power Reduction	Ch.	Freq. (MHz)	Average Power (dBm)	Tune-Up Limit (dBm)	Tune-up Scaling Factor	Power Drift (dB)	Measured 1g SAR (W/kg)	Reported 1g SAR (W/kg)
	LTE Band 4	20M	QPSK	1RB	0offset	Bottom Face	1.3cm	OFF	20300	1745	22.98	24.00	1.265	-0.05	0.593	0.750
	LTE Band 4	20M	QPSK	50RB	0offset	Bottom Face	1.3cm	OFF	20300	1745	21.66	23.00	1.361	-0.04	0.454	0.618
	LTE Band 4	20M	QPSK	1RB	0offset	Edge 1	1.5cm	OFF	20300	1745	22.98	24.00	1.265	-0.03	0.629	0.796
	LTE Band 4	20M	QPSK	50RB	0offset	Edge 1	1.5cm	OFF	20300	1745	21.66	23.00	1.361	0.01	0.486	0.662
	LTE Band 4	20M	QPSK	1RB	0offset	Edge 2	0cm	OFF	20300	1745	22.98	24.00	1.265	-0.06	0.322	0.407
	LTE Band 4	20M	QPSK	50RB	0offset	Edge 2	0cm	OFF	20300	1745	21.66	23.00	1.361	-0.03	0.252	0.343
	LTE Band 4	20M	QPSK	1RB	0offset	Curved surface of Edge 1	1.5cm	OFF	20300	1745	22.98	24.00	1.265	-0.04	0.666	0.842
	LTE Band 4	20M	QPSK	1RB	0offset	Curved surface of Edge 1	1.5cm	OFF	20050	1720	22.90	24.00	1.288	0.03	0.605	0.779
	LTE Band 4	20M	QPSK	1RB	0offset	Curved surface of Edge 1	1.5cm	OFF	20175	1732.5	22.95	24.00	1.274	-0.04	0.627	0.798
	LTE Band 4	20M	QPSK	50RB	0offset	Curved surface of Edge 1	1.5cm	OFF	20300	1745	21.66	23.00	1.361	-0.04	0.511	0.696
	LTE Band 4	20M	QPSK	100RB	0offset	Curved surface of Edge 1	1.5cm	OFF	20300	1745	21.75	23.00	1.334	-0.04	0.498	0.664
	LTE Band 4	20M	QPSK	1RB	0offset	Bottom Face	0cm	ON	20300	1745	17.63	18.00	1.089	-0.19	0.414	0.451
	LTE Band 4	20M	QPSK	50RB	0offset	Bottom Face	0cm	ON	20300	1745	17.39	18.00	1.151	-0.18	0.393	0.452
12	LTE Band 4	20M	QPSK	1RB	0offset	Edge 1	0cm	ON	20300	1745	17.63	18.00	1.089	0.01	0.941	1.025
	LTE Band 4	20M	QPSK	1RB	0offset	Edge 1	0cm	ON	20050	1720	17.46	18.00	1.132	-0.04	0.899	1.018
	LTE Band 4	20M	QPSK	1RB	0offset	Edge 1	0cm	ON	20175	1732.5	17.36	18.00	1.159	-0.09	0.855	0.991
	LTE Band 4	20M	QPSK	50RB	0offset	Edge 1	0cm	ON	20300	1745	17.39	18.00	1.151	-0.06	0.865	0.995
	LTE Band 4	20M	QPSK	50RB	0offset	Edge 1	0cm	ON	20050	1720	17.30	18.00	1.175	-0.02	0.813	0.955
	LTE Band 4	20M	QPSK	50RB	0offset	Edge 1	0cm	ON	20175	1732.5	17.36	18.00	1.159	0.07	0.827	0.958
	LTE Band 4	20M	QPSK	100RB	0offset	Edge 1	0cm	ON	20300	1745	17.41	18.00	1.146	-0.02	0.838	0.960
	LTE Band 4	20M	QPSK	1RB	0offset	Curved surface of Edge 1	0cm	ON	20300	1745	17.63	18.00	1.089	-0.01	0.915	0.996
	LTE Band 4	20M	QPSK	1RB	0offset	Curved surface of Edge 1	0cm	ON	20050	1720	17.46	18.00	1.132	-0.17	0.812	0.920
	LTE Band 4	20M	QPSK	1RB	0offset	Curved surface of Edge 1	0cm	ON	20175	1732.5	17.36	18.00	1.159	0.01	0.814	0.943
	LTE Band 4	20M	QPSK	50RB	0offset	Curved surface of Edge 1	0cm	ON	20300	1745	17.39	18.00	1.151	-0.06	0.761	0.876
	LTE Band 4	20M	QPSK	50RB	0offset	Curved surface of Edge 1	0cm	ON	20050	1720	17.30	18.00	1.175	-0.14	0.764	0.898
	LTE Band 4	20M	QPSK	50RB	0offset	Curved surface of Edge 1	0cm	ON	20175	1732.5	17.36	18.00	1.159	-0.05	0.742	0.860
	LTE Band 4	20M	QPSK	100RB	0offset	Curved surface of Edge 1	0cm	ON	20300	1745	17.41	18.00	1.146	0.06	0.787	0.902
	LTE Band 2	20M	QPSK	1RB	0offset	Bottom Face	1.3cm	OFF	18700	1860	23.12	24.00	1.225	0	0.414	0.507
	LTE Band 2	20M	QPSK	50RB	0offset	Bottom Face	1.3cm	OFF	18700	1860	21.99	23.00	1.262	-0.07	0.305	0.385
	LTE Band 2	20M	QPSK	1RB	0offset	Edge 1	1.5cm	OFF	18700	1860	23.12	24.00	1.225	0.02	0.416	0.509
	LTE Band 2	20M	QPSK	50RB	0offset	Edge 1	1.5cm	OFF	18700	1860	21.99	23.00	1.262	0	0.305	0.385
	LTE Band 2	20M	QPSK	1RB	0offset	Edge 2	0cm	OFF	18700	1860	23.12	24.00	1.225	-0.14	0.280	0.343
	LTE Band 2	20M	QPSK	50RB	0offset	Edge 2	0cm	OFF	18700	1860	21.99	23.00	1.262	-0.17	0.214	0.270
	LTE Band 2	20M	QPSK	1RB	0offset	Curved surface of Edge 1	1.5cm	OFF	18700	1860	23.12	24.00	1.225	0	0.432	0.529
	LTE Band 2	20M	QPSK	50RB	0offset	Curved surface of Edge 1	1.5cm	OFF	18700	1860	21.99	23.00	1.262	-0.01	0.311	0.392
	LTE Band 2	20M	QPSK	1RB	0offset	Bottom Face	0cm	ON	18700	1860	18.99	20.00	1.262	-0.08	0.592	0.747
	LTE Band 2	20M	QPSK	50RB	0offset	Bottom Face	0cm	ON	18700	1860	18.87	20.00	1.297	-0.07	0.548	0.711
13	LTE Band 2	20M	QPSK	1RB	0offset	Edge 1	0cm	ON	18700	1860	18.99	20.00	1.262	-0.06	0.837	1.056
	LTE Band 2	20M	QPSK	1RB	0offset	Edge 1	0cm	ON	18900	1880	18.92	20.00	1.282	-0.03	0.771	0.989
	LTE Band 2	20M	QPSK	1RB	0offset	Edge 1	0cm	ON	19100	1900	18.97	20.00	1.268	-0.04	0.726	0.920
	LTE Band 2	20M	QPSK	50RB	0offset	Edge 1	0cm	ON	18700	1860	18.87	20.00	1.297	0.09	0.772	1.001
	LTE Band 2	20M	QPSK	50RB	0offset	Edge 1	0cm	ON	18900	1880	18.79	20.00	1.321	-0.03	0.731	0.966
	LTE Band 2	20M	QPSK	50RB	0offset	Edge 1	0cm	ON	19100	1900	18.67	20.00	1.358	-0.01	0.676	0.918
	LTE Band 2	20M	QPSK	100RB	0offset	Edge 1	0cm	ON	18700	1860	18.79	20.00	1.321	-0.07	0.760	1.004
	LTE Band 2	20M	QPSK	1RB	0offset	Curved surface of Edge 1	0cm	ON	18700	1860	18.99	20.00	1.262	0	0.743	0.938
	LTE Band 2	20M	QPSK	1RB	0offset	Curved surface of Edge 1	0cm	ON	18900	1880	18.92	20.00	1.282	-0.06	0.685	0.878
	LTE Band 2	20M	QPSK	1RB	0offset	Curved surface of Edge 1	0cm	ON	19100	1900	18.97	20.00	1.268	-0.03	0.630	0.799
	LTE Band 2	20M	QPSK	50RB	0offset	Curved surface of Edge 1	0cm	ON	18700	1860	18.87	20.00	1.297	-0.14	0.707	0.917
	LTE Band 2	20M	QPSK	50RB	0offset	Curved surface of Edge 1	0cm	ON	18900	1880	18.79	20.00	1.321	0.02	0.653	0.863
	LTE Band 2	20M	QPSK	50RB	0offset	Curved surface of Edge 1	0cm	ON	19100	1900	18.67	20.00	1.358	-0.01	0.583	0.792
	LTE Band 2	20M	QPSK	100RB	0offset	Curved surface of Edge 1	0cm	ON	18700	1860	18.79	20.00	1.321	-0.06	0.706	0.933



Plot No.	Band	BW (MHz)	Modulation	RB Size	RB offset	Test Position	Gap (cm)	Power Reduction	Ch.	Freq. (MHz)	Average Power (dBm)	Tune-Up Limit (dBm)	Tune-up Scaling Factor	Power Drift (dB)	Measured 1g SAR (W/kg)	Reported 1g SAR (W/kg)
	LTE Band 25	20M	QPSK	1RB	0offset	Bottom Face	1.3cm	OFF	26340	1880	23.09	24.00	1.233	-0.01	0.329	0.406
	LTE Band 25	20M	QPSK	50RB	0offset	Bottom Face	1.3cm	OFF	26340	1880	21.92	23.00	1.282	-0.03	0.246	0.315
	LTE Band 25	20M	QPSK	1RB	0offset	Edge 1	1.5cm	OFF	26340	1880	23.09	24.00	1.233	0.02	0.351	0.433
	LTE Band 25	20M	QPSK	50RB	0offset	Edge 1	1.5cm	OFF	26340	1880	21.92	23.00	1.282	0.1	0.291	0.373
	LTE Band 25	20M	QPSK	1RB	0offset	Edge 2	0cm	OFF	26340	1880	23.09	24.00	1.233	0.01	0.254	0.313
	LTE Band 25	20M	QPSK	50RB	0offset	Edge 2	0cm	OFF	26340	1880	21.92	23.00	1.282	0	0.186	0.239
	LTE Band 25	20M	QPSK	1RB	0offset	Curved surface of Edge 1	1.5cm	OFF	26340	1880	23.09	24.00	1.233	-0.03	0.380	0.469
	LTE Band 25	20M	QPSK	50RB	0offset	Curved surface of Edge 1	1.5cm	OFF	26340	1880	21.92	23.00	1.282	0	0.276	0.354
	LTE Band 25	20M	QPSK	1RB	0offset	Bottom Face	0cm	ON	26340	1880	18.91	20.00	1.285	-0.09	0.509	0.654
	LTE Band 25	20M	QPSK	50RB	0offset	Bottom Face	0cm	ON	26340	1880	18.64	20.00	1.368	-0.02	0.457	0.625
	LTE Band 25	20M	QPSK	1RB	0offset	Edge 1	0cm	ON	26340	1880	18.91	20.00	1.285	-0.07	0.772	0.992
14	LTE Band 25	20M	QPSK	1RB	0offset	Edge 1	0cm	ON	26140	1860	18.79	20.00	1.321	-0.04	0.812	1.073
	LTE Band 25	20M	QPSK	1RB	0offset	Edge 1	0cm	ON	26590	1905	18.69	20.00	1.352	-0.09	0.716	0.968
	LTE Band 25	20M	QPSK	50RB	0offset	Edge 1	0cm	ON	26340	1880	18.64	20.00	1.368	-0.12	0.711	0.972
	LTE Band 25	20M	QPSK	50RB	0offset	Edge 1	0cm	ON	26140	1860	18.63	20.00	1.371	-0.06	0.750	1.028
	LTE Band 25	20M	QPSK	50RB	0offset	Edge 1	0cm	ON	26590	1905	18.55	20.00	1.396	-0.11	0.666	0.930
	LTE Band 25	20M	QPSK	100RB	0offset	Edge 1	0cm	ON	26340	1880	18.59	20.00	1.384	-0.05	0.695	0.962
	LTE Band 25	20M	QPSK	1RB	0offset	Curved surface of Edge 1	0cm	ON	26340	1880	18.91	20.00	1.285	-0.04	0.678	0.871
	LTE Band 25	20M	QPSK	1RB	0offset	Curved surface of Edge 1	0cm	ON	26140	1860	18.79	20.00	1.321	-0.04	0.741	0.979
	LTE Band 25	20M	QPSK	1RB	0offset	Curved surface of Edge 1	0cm	ON	26590	1905	18.69	20.00	1.352	-0.05	0.601	0.813
	LTE Band 25	20M	QPSK	50RB	0offset	Curved surface of Edge 1	0cm	ON	26340	1880	18.64	20.00	1.368	-0.08	0.629	0.860
	LTE Band 25	20M	QPSK	50RB	0offset	Curved surface of Edge 1	0cm	ON	26140	1860	18.63	20.00	1.371	-0.03	0.684	0.938
	LTE Band 25	20M	QPSK	50RB	0offset	Curved surface of Edge 1	0cm	ON	26590	1905	18.55	20.00	1.396	-0.08	0.560	0.782
	LTE Band 25	20M	QPSK	100RB	0offset	Curved surface of Edge 1	0cm	ON	26340	1880	18.59	20.00	1.384	-0.06	0.611	0.845

15.2 Repeated SAR Measurement

No.	Band	Mode	Test Position	Gap (cm)	Power Reduction	Ch.	Freq. (MHz)	Average Power (dBm)	Tune-Up Limit (dBm)	Tune-up Scaling Factor	Power Drift (dB)	Measured 1g SAR (W/kg)	Ratio	Reported 1g SAR (W/kg)
1st	GSM1900	GPRS (2 Tx slots)	Edge 1	0cm	ON	512	1850.2	25.85	26.00	1.035	-0.15	1.040	-	1.077
2nd	GSM1900	GPRS (2 Tx slots)	Edge 1	0cm	ON	512	1850.2	25.85	26.00	1.035	-0.06	0.905	1.15	0.937

No.	Band	BW (MHz)	Modulation	RB Size	RB offset	Test Position	Gap (cm)	Power Reduction	Ch.	Freq. (MHz)	Average Power (dBm)	Tune-Up Limit (dBm)	Tune-up Scaling Factor	Power Drift (dB)	Measured 1g SAR (W/kg)	Ratio	Reported 1g SAR (W/kg)
1st	LTE Band 5	10M	QPSK	1RB	0offset	Curved surface of Edge 1	0cm	ON	20600	844	18.68	19.00	1.076	0.05	0.917	-	0.987
2nd	LTE Band 5	10M	QPSK	1RB	0offset	Curved surface of Edge 1	0cm	ON	20600	844	18.68	19.00	1.076	-0.03	0.913	1.00	0.983
1st	LTE Band 4	20M	QPSK	1RB	0offset	Edge 1	0cm	ON	20300	1745	17.63	18.00	1.089	0.01	0.941	-	1.025
2nd	LTE Band 4	20M	QPSK	1RB	0offset	Edge 1	0cm	ON	20300	1745	17.63	18.00	1.089	-0.04	0.923	1.02	1.005

General Note:

- Per KDB 865664 D01v01r03, for each frequency band, repeated SAR measurement is required only when the measured SAR is $\geq 0.8W/kg$
- Per KDB 865664 D01v01r03, if the ratio among the repeated measurement is ≤ 1.2 and the measured SAR $< 1.45W/kg$, only one repeated measurement is required.
- The ratio is the difference in percentage between original and repeated *measured* SAR.
- All measurement SAR result is scaled-up to account for tune-up tolerance and is compliant.

16. Simultaneous Transmission Analysis

NO.	Simultaneous Transmission Configurations	Tablet	Note
		Body	
1.	GPRS/EDGE(Data) + WLAN2.4GHz(data)	Yes	2.4GHz Hotspot
2.	WCDMA(Data) + WLAN2.4GHz(data)	Yes	2.4GHz Hotspot
3.	CDMA(Data) + WLAN2.4GHz(data)	Yes	2.4GHz Hotspot
4.	LTE(Data) + WLAN2.4GHz(data)	Yes	2.4GHz Hotspot
5.	GPRS/EDGE(Data) + Bluetooth(data)	Yes	Bluetooth Tethering
6.	WCDMA(Data) + Bluetooth(data)	Yes	Bluetooth Tethering
7.	CDMA(Data) + Bluetooth(data)	Yes	Bluetooth Tethering
8.	LTE(Data) + Bluetooth(data)	Yes	Bluetooth Tethering
9.	GPRS/EDGE(data) + WLAN5GHz(data)	No	
10.	WCDMA(data) + WLAN5GHz(data)	No	
11.	CDMA(data) + WLAN5 GHz(data)	No	
12.	LTE(data) + WLAN5GHz(data)	No	

General Note:

1. The WLAN/BT module, Intel 7265NGW, FCC ID: Q2G7265NG is also integrated into this host and the WLAN and Bluetooth SAR testing results are also used perform transmission simultaneous analysis which can be referred to RF Exposure Lab SAR Evaluation Report, Report No: FA520236-01.
2. WLAN RF exposure assessment of MIMO mode simultaneous transmission exclusion analysis was performed with SAR test results of each antenna in SISO mode. Therefore SPLSR calculation was choose worst case with SAR test results of each antenna in SISO mode perform evaluation.
3. The worst case WLAN reported SAR for each configuration was used for SAR summation, regardless of whether the WLAN channel has WiFi Direct and Hotspot capability. Therefore, the following summations represent the absolute worst cases for simultaneous transmission with WLAN.
4. For simultaneous transmission analysis for exposure position of edge1 1.5cm and bottom face 1.3cm and curved surface of Edge 1 1.5cm, WLAN SAR tested at 0mm separation is worse and the test data is used for conservative SAR summation.
5. For co-location analysis:
 - i) For WWAN SAR testing was performed on bottom face, Edge1 and Edge2, according to KDB 447498 D01v05r02 exclusion thresholds which can be referred to page51.
 - ii) The WLAN SAR testing was performed on bottom face, Edge1 and Edge4, according to KDB 447498 D01v05r02 exclusion thresholds which can be referred to Sporton FCC SAR Report, FCC ID: Q2G7265NG, Report No: FA 520236-01 Rev.01 page26.
 - iii) For co-location analysis was performed at the same exposure positions, which are bottom face and Edge1, where both WWAN standalone SAR and WLAN standalone SAR was assessed.
6. The Scaled SAR summation is calculated based on the same configuration and test position.
7. Per KDB 447498 D01v05r02, simultaneous transmission SAR is compliant if,
 - i) Scalar SAR summation < 1.6W/kg.
 - ii) $SPLSR = (SAR1 + SAR2)^{1.5} / (\text{min. separation distance, mm})$, and the peak separation distance is determined from the square root of $[(x1-x2)^2 + (y1-y2)^2 + (z1-z2)^2]$, where (x1, y1, z1) and (x2, y2, z2) are the coordinates of the extrapolated peak SAR locations in the zoom scan.
 - iii) If $SPLSR \leq 0.04$, simultaneously transmission SAR measurement is not necessary.
 - iv) Simultaneously transmission SAR measurement, and the reported multi-band SAR < 1.6W/kg.
 - v) The SPLSR calculated results please refer to section 16.2.



16.1 Body Exposure Conditions

WWAN Band	Exposure Position	1		2		1+2 Summed SAR (W/kg)	SPLSR	Case No	
		WWAN	2.4GHz / 5.8GHz	WLAN Antenna A					
		SAR (W/kg)	Band	SAR (W/kg)					
GSM	GSM850	Bottom Face at 1.3 cm	0.551	2.4GHz	0.393	0.94			
		Edge 1 at 1.5cm	0.490	5.8GHz	0.421	0.91			
		Edge 2 at 0cm	0.135			0.14			
		Curved surface of Edge 1 1.5cm	0.643	2.4GHz	0.439	1.08			
		Bottom Face at 0 cm	0.598	2.4GHz	0.393	0.99			
		Edge 1 at 0cm	0.761	5.8GHz	0.421	1.18			
	GSM1900	Curved surface of Edge 1 0cm	0.905	2.4GHz	0.393	1.30			
		Bottom Face at 1.3 cm	0.329	2.4GHz	0.393	0.72			
		Edge 1 at 1.5cm	0.390	5.8GHz	0.421	0.81			
		Edge 2 at 0cm	0.281			0.28			
		Curved surface of Edge 1 1.5cm	0.418	2.4GHz	0.439	0.86			
		Bottom Face at 0 cm	0.180	2.4GHz	0.393	0.57			
		Edge 1 at 0cm	1.077	5.8GHz	0.421	1.50			
		Curved surface of Edge 1 0cm	0.978	2.4GHz	0.393	1.37			
WCDMA	Band V	Bottom Face at 1.3 cm	0.356	2.4GHz	0.393	0.75			
		Edge 1 at 1.5cm	0.314	5.8GHz	0.421	0.74			
		Edge 2 at 0cm	0.091			0.09			
		Curved surface of Edge 1 1.5cm	0.433	2.4GHz	0.439	0.87			
		Bottom Face at 0 cm	0.336	2.4GHz	0.393	0.73			
		Edge 1 at 0cm	0.624	5.8GHz	0.421	1.05			
		Curved surface of Edge 1 0cm	0.900	2.4GHz	0.393	1.29			
		Band IV	Bottom Face at 1.3 cm	0.659	2.4GHz	0.393	1.05		
	Edge 1 at 1.5cm		0.741	5.8GHz	0.421	1.16			
	Edge 2 at 0cm		0.395			0.40			
	Curved surface of Edge 1 1.5cm		0.779	2.4GHz	0.439	1.22			
	Bottom Face at 0 cm		0.320	2.4GHz	0.393	0.71			
	Edge 1 at 0cm		0.909	5.8GHz	0.421	1.33			
	Curved surface of Edge 1 0cm		0.781	2.4GHz	0.393	1.17			
	Band II		Bottom Face at 1.3 cm	0.385	2.4GHz	0.393	0.78		
		Edge 1 at 1.5cm	0.458	5.8GHz	0.421	0.88			
		Edge 2 at 0cm	0.320			0.32			
		Curved surface of Edge 1 1.5cm	0.437	2.4GHz	0.439	0.88			
		Bottom Face at 0 cm	0.388	2.4GHz	0.393	0.78			
		Edge 1 at 0cm	0.992	5.8GHz	0.421	1.41			
		Curved surface of Edge 1 0cm	0.662	2.4GHz	0.393	1.06			
		CDMA	BC10	Bottom Face at 1.3 cm	0.380	2.4GHz	0.393	0.77	
	Edge 1 at 1.5cm			0.348	5.8GHz	0.421	0.77		
	Edge 2 at 0cm			0.137			0.14		
Curved surface of Edge 1 1.5cm	0.430			2.4GHz	0.439	0.87			
Bottom Face at 0 cm	0.742			2.4GHz	0.393	1.14			
Edge 1 at 0cm	0.792			5.8GHz	0.421	1.21			
BC0	Curved surface of Edge 1 0cm		0.853	2.4GHz	0.393	1.25			
	Bottom Face at 1.3 cm		0.426	2.4GHz	0.393	0.82			
	Edge 1 at 1.5cm		0.429	5.8GHz	0.421	0.85			
	Edge 2 at 0cm		0.117			0.12			
	Curved surface of Edge 1 1.5cm		0.523	2.4GHz	0.439	0.96			
	Bottom Face at 0 cm		0.874	2.4GHz	0.393	1.27			
	Edge 1 at 0cm		0.969	5.8GHz	0.421	1.39			
	Curved surface of Edge 1 0cm		1.044	2.4GHz	0.393	1.44			
	BC1		Bottom Face at 1.3 cm	0.541	2.4GHz	0.393	0.93		
			Edge 1 at 1.5cm	0.665	5.8GHz	0.421	1.09		
			Edge 2 at 0cm	0.400			0.40		
			Curved surface of Edge 1 1.5cm	0.695	2.4GHz	0.439	1.13		
Bottom Face at 0 cm			0.589	2.4GHz	0.393	0.98			
Edge 1 at 0cm			0.874	5.8GHz	0.421	1.30			
Curved surface of Edge 1 0cm	0.775		2.4GHz	0.393	1.17				



WWAN Band	Exposure Position	1	2		1+2 Summed SAR (W/kg)	SPLSR	Case No
		WWAN	2.4GHz / 5.8GHz WLAN Antenna A				
		SAR (W/kg)	Band	SAR (W/kg)			
LTE	Band 17	Bottom Face at 1.3 cm	0.356	2.4GHz	0.393	0.75	
		Edge 1 at 1.5cm	0.172	5.8GHz	0.421	0.59	
		Edge 2 at 0cm	0.181			0.18	
		Curved surface of Edge 1 1.5cm	0.283	2.4GHz	0.439	0.72	
		Bottom Face at 0 cm	0.682	2.4GHz	0.393	1.08	
		Edge 1 at 0cm	0.581	5.8GHz	0.421	1.00	
	Band 13	Curved surface of Edge 1 0cm	0.763	2.4GHz	0.393	1.16	
		Bottom Face at 1.3 cm	0.312	2.4GHz	0.393	0.71	
		Edge 1 at 1.5cm	0.134	5.8GHz	0.421	0.56	
		Edge 2 at 0cm	0.085			0.09	
		Curved surface of Edge 1 1.5cm	0.238	2.4GHz	0.439	0.68	
		Bottom Face at 0 cm	0.464	2.4GHz	0.393	0.86	
	Band 5	Edge 1 at 0cm	0.471	5.8GHz	0.421	0.89	
		Curved surface of Edge 1 0cm	0.627	2.4GHz	0.393	1.02	
		Bottom Face at 1.3 cm	0.381	2.4GHz	0.393	0.77	
		Edge 1 at 1.5cm	0.331	5.8GHz	0.421	0.75	
		Edge 2 at 0cm	0.093			0.09	
		Curved surface of Edge 1 1.5cm	0.387	2.4GHz	0.439	0.83	
	Band 4	Bottom Face at 0 cm	0.622	2.4GHz	0.393	1.02	
		Edge 1 at 0cm	0.747	5.8GHz	0.421	1.17	
		Curved surface of Edge 1 0cm	0.987	2.4GHz	0.393	1.38	
		Bottom Face at 1.3 cm	0.750	2.4GHz	0.393	1.14	
		Edge 1 at 1.5cm	0.796	5.8GHz	0.421	1.22	
		Edge 2 at 0cm	0.407			0.41	
	Band 2	Curved surface of Edge 1 1.5cm	0.842	2.4GHz	0.439	1.28	
		Bottom Face at 0 cm	0.452	2.4GHz	0.393	0.85	
		Edge 1 at 0cm	1.025	5.8GHz	0.421	1.45	
		Curved surface of Edge 1 0cm	0.996	2.4GHz	0.393	1.39	
		Bottom Face at 1.3 cm	0.507	2.4GHz	0.393	0.90	
		Edge 1 at 1.5cm	0.509	5.8GHz	0.421	0.93	
	Band 25	Edge 2 at 0cm	0.343			0.34	
		Curved surface of Edge 1 1.5cm	0.529	2.4GHz	0.439	0.97	
		Bottom Face at 0 cm	0.747	2.4GHz	0.393	1.14	
		Edge 1 at 0cm	1.056	5.8GHz	0.421	1.48	
		Curved surface of Edge 1 0cm	0.938	2.4GHz	0.393	1.33	
		Bottom Face at 1.3 cm	0.406	2.4GHz	0.393	0.80	
	Band 25	Edge 1 at 1.5cm	0.433	5.8GHz	0.421	0.85	
		Edge 2 at 0cm	0.313			0.31	
		Curved surface of Edge 1 1.5cm	0.469	2.4GHz	0.439	0.91	
		Bottom Face at 0 cm	0.654	2.4GHz	0.393	1.05	
		Edge 1 at 0cm	1.073	5.8GHz	0.421	1.49	
		Curved surface of Edge 1 0cm	0.979	2.4GHz	0.393	1.37	



WWAN Band		Exposure Position	1	3		1+3 Summed SAR (W/kg)	SPLSR	Case No	
			WWAN	2.4GHz / 5.8GHz WLAN Antenna B					
			SAR (W/kg)	Band	SAR (W/kg)				
GSM	GSM850	Bottom Face at 1.3 cm	0.551	2.4GHz	0.227	0.78			
		Edge 1 at 1.5cm	0.490	5.8GHz	0.390	0.88			
		Edge 2 at 0cm	0.135			0.14			
		Curved surface of Edge 1 1.5cm	0.643	5.8GHz	0.419	1.06			
		Bottom Face at 0 cm	0.598	2.4GHz	0.227	0.83			
		Edge 1 at 0cm	0.761	5.8GHz	0.390	1.15			
	GSM1900	Curved surface of Edge 1 0cm	0.905	5.8GHz	0.419	1.32			
		Bottom Face at 1.3 cm	0.329	2.4GHz	0.227	0.56			
		Edge 1 at 1.5cm	0.390	5.8GHz	0.390	0.78			
		Edge 2 at 0cm	0.281			0.28			
		Curved surface of Edge 1 1.5cm	0.418	5.8GHz	0.419	0.84			
		Bottom Face at 0 cm	0.180	2.4GHz	0.227	0.41			
		Edge 1 at 0cm	1.077	5.8GHz	0.390	1.47			
		Curved surface of Edge 1 0cm	0.978	5.8GHz	0.419	1.40			
WCDMA	Band V	Bottom Face at 1.3 cm	0.356	2.4GHz	0.227	0.58			
		Edge 1 at 1.5cm	0.314	5.8GHz	0.390	0.70			
		Edge 2 at 0cm	0.091			0.09			
		Curved surface of Edge 1 1.5cm	0.433	5.8GHz	0.419	0.85			
		Bottom Face at 0 cm	0.336	2.4GHz	0.227	0.56			
		Edge 1 at 0cm	0.624	5.8GHz	0.390	1.01			
	Band IV	Curved surface of Edge 1 0cm	0.900	5.8GHz	0.419	1.32			
		Bottom Face at 1.3 cm	0.659	2.4GHz	0.227	0.89			
		Edge 1 at 1.5cm	0.741	5.8GHz	0.390	1.13			
		Edge 2 at 0cm	0.395			0.40			
		Curved surface of Edge 1 1.5cm	0.779	5.8GHz	0.419	1.20			
		Bottom Face at 0 cm	0.320	2.4GHz	0.227	0.55			
	Band II	Edge 1 at 0cm	0.909	5.8GHz	0.390	1.30			
		Curved surface of Edge 1 0cm	0.781	5.8GHz	0.419	1.20			
		Bottom Face at 1.3 cm	0.385	2.4GHz	0.227	0.61			
		Edge 1 at 1.5cm	0.458	5.8GHz	0.390	0.85			
		Edge 2 at 0cm	0.320			0.32			
		Curved surface of Edge 1 1.5cm	0.437	5.8GHz	0.419	0.86			
	CDMA	BC10	Bottom Face at 0 cm	0.388	2.4GHz	0.227	0.62		
			Edge 1 at 0cm	0.992	5.8GHz	0.390	1.38		
			Curved surface of Edge 1 0cm	0.662	5.8GHz	0.419	1.08		
			Bottom Face at 1.3 cm	0.380	2.4GHz	0.227	0.61		
			Edge 1 at 1.5cm	0.348	5.8GHz	0.390	0.74		
			Edge 2 at 0cm	0.137			0.14		
BC0		Curved surface of Edge 1 1.5cm	0.430	5.8GHz	0.419	0.85			
		Bottom Face at 0 cm	0.742	2.4GHz	0.227	0.97			
		Edge 1 at 0cm	0.792	5.8GHz	0.390	1.18			
		Curved surface of Edge 1 0cm	0.853	5.8GHz	0.419	1.27			
		Bottom Face at 1.3 cm	0.426	2.4GHz	0.227	0.65			
		Edge 1 at 1.5cm	0.429	5.8GHz	0.390	0.82			
BC1		Edge 2 at 0cm	0.117			0.12			
		Curved surface of Edge 1 1.5cm	0.523	5.8GHz	0.419	0.94			
		Bottom Face at 0 cm	0.874	2.4GHz	0.227	1.10			
		Edge 1 at 0cm	0.969	5.8GHz	0.390	1.36			
		Curved surface of Edge 1 0cm	1.044	5.8GHz	0.419	1.46			
		Bottom Face at 1.3 cm	0.541	2.4GHz	0.227	0.77			
BC1	Edge 1 at 1.5cm	0.665	5.8GHz	0.390	1.06				
	Edge 2 at 0cm	0.400			0.40				
	Curved surface of Edge 1 1.5cm	0.695	5.8GHz	0.419	1.11				
	Bottom Face at 0 cm	0.589	2.4GHz	0.227	0.82				
	Edge 1 at 0cm	0.874	5.8GHz	0.390	1.26				
	Curved surface of Edge 1 0cm	0.775	5.8GHz	0.419	1.19				



WWAN Band	Exposure Position	1	3		1+3 Summed SAR (W/kg)	SPLSR	Case No
		WWAN	2.4GHz / 5.8GHz WLAN Antenna B				
		SAR (W/kg)	Band	SAR (W/kg)			
LTE	Band 17	Bottom Face at 1.3 cm	0.356	2.4GHz	0.227	0.58	
		Edge 1 at 1.5cm	0.172	5.8GHz	0.390	0.56	
		Edge 2 at 0cm	0.181			0.18	
		Curved surface of Edge 1 1.5cm	0.283	5.8GHz	0.419	0.70	
		Bottom Face at 0 cm	0.682	2.4GHz	0.227	0.91	
		Edge 1 at 0cm	0.581	5.8GHz	0.390	0.97	
	Band 13	Curved surface of Edge 1 0cm	0.763	5.8GHz	0.419	1.18	
		Bottom Face at 1.3 cm	0.312	2.4GHz	0.227	0.54	
		Edge 1 at 1.5cm	0.134	5.8GHz	0.390	0.52	
		Edge 2 at 0cm	0.085			0.09	
		Curved surface of Edge 1 1.5cm	0.238	5.8GHz	0.419	0.66	
		Bottom Face at 0 cm	0.464	2.4GHz	0.227	0.69	
	Band 5	Edge 1 at 0cm	0.471	5.8GHz	0.390	0.86	
		Curved surface of Edge 1 0cm	0.627	5.8GHz	0.419	1.05	
		Bottom Face at 1.3 cm	0.381	2.4GHz	0.227	0.61	
		Edge 1 at 1.5cm	0.331	5.8GHz	0.390	0.72	
		Edge 2 at 0cm	0.093			0.09	
		Curved surface of Edge 1 1.5cm	0.387	5.8GHz	0.419	0.81	
	Band 4	Bottom Face at 0 cm	0.622	2.4GHz	0.227	0.85	
		Edge 1 at 0cm	0.747	5.8GHz	0.390	1.14	
		Curved surface of Edge 1 0cm	0.987	5.8GHz	0.419	1.41	
		Bottom Face at 1.3 cm	0.750	2.4GHz	0.227	0.98	
		Edge 1 at 1.5cm	0.796	5.8GHz	0.390	1.19	
		Edge 2 at 0cm	0.407			0.41	
	Band 2	Curved surface of Edge 1 1.5cm	0.842	5.8GHz	0.419	1.26	
		Bottom Face at 0 cm	0.452	2.4GHz	0.227	0.68	
		Edge 1 at 0cm	1.025	5.8GHz	0.390	1.42	
		Curved surface of Edge 1 0cm	0.996	5.8GHz	0.419	1.42	
		Bottom Face at 1.3 cm	0.507	2.4GHz	0.227	0.73	
		Edge 1 at 1.5cm	0.509	5.8GHz	0.390	0.90	
	Band 25	Edge 2 at 0cm	0.343			0.34	
		Curved surface of Edge 1 1.5cm	0.529	5.8GHz	0.419	0.95	
		Bottom Face at 0 cm	0.747	2.4GHz	0.227	0.97	
		Edge 1 at 0cm	1.056	5.8GHz	0.390	1.45	
		Curved surface of Edge 1 0cm	0.938	5.8GHz	0.419	1.36	
		Bottom Face at 1.3 cm	0.406	2.4GHz	0.227	0.63	
	Band 25	Edge 1 at 1.5cm	0.433	5.8GHz	0.390	0.82	
		Edge 2 at 0cm	0.313			0.31	
		Curved surface of Edge 1 1.5cm	0.469	5.8GHz	0.419	0.89	
		Bottom Face at 0 cm	0.654	2.4GHz	0.227	0.88	
		Edge 1 at 0cm	1.073	5.8GHz	0.390	1.46	
		Curved surface of Edge 1 0cm	0.979	5.8GHz	0.419	1.40	



WWAN Band		Exposure Position	1	4	1+4 Summed SAR (W/kg)	SPLSR	Case No
			WWAN SAR (W/kg)	2.4GHz Bluetooth Estimated SAR (W/kg)			
GSM	GSM850	Bottom Face at 1.3 cm	0.551	0.168	0.72		
		Edge 1 at 1.5cm	0.490	0.168	0.66		
		Edge 2 at 0cm	0.135	0.168	0.30		
		Curved surface of Edge 1 1.5cm	0.643	0.168	0.81		
		Bottom Face at 0 cm	0.598	0.168	0.77		
		Edge 1 at 0cm	0.761	0.168	0.93		
	GSM1900	Curved surface of Edge 1 0cm	0.905	0.168	1.07		
		Bottom Face at 1.3 cm	0.329	0.168	0.50		
		Edge 1 at 1.5cm	0.390	0.168	0.56		
		Edge 2 at 0cm	0.281	0.168	0.45		
		Curved surface of Edge 1 1.5cm	0.418	0.168	0.59		
		Bottom Face at 0 cm	0.180	0.168	0.35		
		Edge 1 at 0cm	1.077	0.168	1.25		
		Curved surface of Edge 1 0cm	0.978	0.168	1.15		
WCDMA	Band V	Bottom Face at 1.3 cm	0.356	0.168	0.52		
		Edge 1 at 1.5cm	0.314	0.168	0.48		
		Edge 2 at 0cm	0.091	0.168	0.26		
		Curved surface of Edge 1 1.5cm	0.433	0.168	0.60		
		Bottom Face at 0 cm	0.336	0.168	0.50		
		Edge 1 at 0cm	0.624	0.168	0.79		
		Curved surface of Edge 1 0cm	0.900	0.168	1.07		
	Band IV	Bottom Face at 1.3 cm	0.659	0.168	0.83		
		Edge 1 at 1.5cm	0.741	0.168	0.91		
		Edge 2 at 0cm	0.395	0.168	0.56		
		Curved surface of Edge 1 1.5cm	0.779	0.168	0.95		
		Bottom Face at 0 cm	0.320	0.168	0.49		
		Edge 1 at 0cm	0.909	0.168	1.08		
	Band II	Curved surface of Edge 1 0cm	0.781	0.168	0.95		
		Bottom Face at 1.3 cm	0.385	0.168	0.55		
		Edge 1 at 1.5cm	0.458	0.168	0.63		
		Edge 2 at 0cm	0.320	0.168	0.49		
		Curved surface of Edge 1 1.5cm	0.437	0.168	0.61		
		Bottom Face at 0 cm	0.388	0.168	0.56		
		Edge 1 at 0cm	0.992	0.168	1.16		
	CDMA	BC10	Curved surface of Edge 1 0cm	0.662	0.168	0.83	
Bottom Face at 1.3 cm			0.380	0.168	0.55		
Edge 1 at 1.5cm			0.348	0.168	0.52		
Edge 2 at 0cm			0.137	0.168	0.31		
Curved surface of Edge 1 1.5cm			0.430	0.168	0.60		
Bottom Face at 0 cm			0.742	0.168	0.91		
BC0		Edge 1 at 0cm	0.792	0.168	0.96		
		Curved surface of Edge 1 0cm	0.853	0.168	1.02		
		Bottom Face at 1.3 cm	0.426	0.168	0.59		
		Edge 1 at 1.5cm	0.429	0.168	0.60		
		Edge 2 at 0cm	0.117	0.168	0.29		
		Curved surface of Edge 1 1.5cm	0.523	0.168	0.69		
		Bottom Face at 0 cm	0.874	0.168	1.04		
BC1		Edge 1 at 0cm	0.969	0.168	1.14		
		Curved surface of Edge 1 0cm	1.044	0.168	1.21		
		Bottom Face at 1.3 cm	0.541	0.168	0.71		
		Edge 1 at 1.5cm	0.665	0.168	0.83		
		Edge 2 at 0cm	0.400	0.168	0.57		
		Curved surface of Edge 1 1.5cm	0.695	0.168	0.86		
		Bottom Face at 0 cm	0.589	0.168	0.76		
Edge 1 at 0cm		0.874	0.168	1.04			
Curved surface of Edge 1 0cm	0.775	0.168	0.94				



WWAN Band		Exposure Position	1	4	1+4 Summed SAR (W/kg)	SPLSR	Case No
			WWAN SAR (W/kg)	2.4GHz Bluetooth Estimated SAR (W/kg)			
LTE	Band 17	Bottom Face at 1.3 cm	0.356	0.168	0.52		
		Edge 1 at 1.5cm	0.172	0.168	0.34		
		Edge 2 at 0cm	0.181	0.168	0.35		
		Curved surface of Edge 1 1.5cm	0.283	0.168	0.45		
		Bottom Face at 0 cm	0.682	0.168	0.85		
		Edge 1 at 0cm	0.581	0.168	0.75		
	Band 13	Curved surface of Edge 1 0cm	0.763	0.168	0.93		
		Bottom Face at 1.3 cm	0.312	0.168	0.48		
		Edge 1 at 1.5cm	0.134	0.168	0.30		
		Edge 2 at 0cm	0.085	0.168	0.25		
		Curved surface of Edge 1 1.5cm	0.238	0.168	0.41		
		Bottom Face at 0 cm	0.464	0.168	0.63		
	Band 5	Edge 1 at 0cm	0.471	0.168	0.64		
		Curved surface of Edge 1 0cm	0.627	0.168	0.80		
		Bottom Face at 1.3 cm	0.381	0.168	0.55		
		Edge 1 at 1.5cm	0.331	0.168	0.50		
		Edge 2 at 0cm	0.093	0.168	0.26		
		Curved surface of Edge 1 1.5cm	0.387	0.168	0.56		
	Band 4	Bottom Face at 0 cm	0.622	0.168	0.79		
		Edge 1 at 0cm	0.747	0.168	0.92		
		Curved surface of Edge 1 0cm	0.987	0.168	1.16		
		Bottom Face at 1.3 cm	0.750	0.168	0.92		
		Edge 1 at 1.5cm	0.796	0.168	0.96		
		Edge 2 at 0cm	0.407	0.168	0.58		
	Band 2	Curved surface of Edge 1 1.5cm	0.842	0.168	1.01		
		Bottom Face at 0 cm	0.452	0.168	0.62		
		Edge 1 at 0cm	1.025	0.168	1.19		
		Curved surface of Edge 1 0cm	0.996	0.168	1.16		
		Bottom Face at 1.3 cm	0.507	0.168	0.68		
		Edge 1 at 1.5cm	0.509	0.168	0.68		
Band 25	Edge 2 at 0cm	0.343	0.168	0.51			
	Curved surface of Edge 1 1.5cm	0.529	0.168	0.70			
	Bottom Face at 0 cm	0.747	0.168	0.92			
	Edge 1 at 0cm	1.056	0.168	1.22			
	Curved surface of Edge 1 0cm	0.938	0.168	1.11			
	Bottom Face at 1.3 cm	0.406	0.168	0.57			
Band 25	Edge 1 at 1.5cm	0.433	0.168	0.60			
	Edge 2 at 0cm	0.313	0.168	0.48			
	Curved surface of Edge 1 1.5cm	0.469	0.168	0.64			
	Bottom Face at 0 cm	0.654	0.168	0.82			
	Edge 1 at 0cm	1.073	0.168	1.24			
	Curved surface of Edge 1 0cm	0.979	0.168	1.15			



WWAN Band		Exposure Position	1	2		1+2 Summed SAR (W/kg)	SPLSR	Case No	
			WWAN	5.2GHz / 5.3GHz / 5.5GHz WLAN Antenna A					
			SAR (W/kg)	Band	SAR (W/kg)				
GSM	GSM850	Bottom Face at 1.3 cm	0.551	5.3GHz	0.163	0.71			
		Edge 1 at 1.5cm	0.490	5.2GHz	0.675	1.17			
		Edge 2 at 0cm	0.135			0.14			
		Curved surface of Edge 1 1.5cm	0.643	5.3GHz	0.289	0.93			
		Bottom Face at 0 cm	0.598	5.3GHz	0.163	0.76			
		Edge 1 at 0cm	0.761	5.2GHz	0.675	1.44			
	GSM1900	Curved surface of Edge 1 0cm	0.905	5.3GHz	0.289	1.19			
		Bottom Face at 1.3 cm	0.329	5.3GHz	0.163	0.49			
		Edge 1 at 1.5cm	0.390	5.2GHz	0.675	1.07			
		Edge 2 at 0cm	0.281			0.28			
		Curved surface of Edge 1 1.5cm	0.418	5.3GHz	0.289	0.71			
		Bottom Face at 0 cm	0.180	5.3GHz	0.163	0.34			
		Edge 1 at 0cm	1.077	5.2GHz	0.675	1.75	0.01	Case 1	
		Curved surface of Edge 1 0cm	0.978	5.3GHz	0.289	1.27			
WCDMA	Band V	Bottom Face at 1.3 cm	0.356	5.3GHz	0.163	0.52			
		Edge 1 at 1.5cm	0.314	5.2GHz	0.675	0.99			
		Edge 2 at 0cm	0.091			0.09			
		Curved surface of Edge 1 1.5cm	0.433	5.3GHz	0.289	0.72			
		Bottom Face at 0 cm	0.336	5.3GHz	0.163	0.50			
		Edge 1 at 0cm	0.624	5.2GHz	0.675	1.30			
	Band IV	Curved surface of Edge 1 0cm	0.900	5.3GHz	0.289	1.19			
		Bottom Face at 1.3 cm	0.659	5.3GHz	0.163	0.82			
		Edge 1 at 1.5cm	0.741	5.2GHz	0.675	1.42			
		Edge 2 at 0cm	0.395			0.40			
		Curved surface of Edge 1 1.5cm	0.779	5.3GHz	0.289	1.07			
		Bottom Face at 0 cm	0.320	5.3GHz	0.163	0.48			
	Band II	Edge 1 at 0cm	0.909	5.2GHz	0.675	1.58			
		Curved surface of Edge 1 0cm	0.781	5.3GHz	0.289	1.07			
		Bottom Face at 1.3 cm	0.385	5.3GHz	0.163	0.55			
		Edge 1 at 1.5cm	0.458	5.2GHz	0.675	1.13			
		Edge 2 at 0cm	0.320			0.32			
		Curved surface of Edge 1 1.5cm	0.437	5.3GHz	0.289	0.73			
	CDMA	BC10	Bottom Face at 0 cm	0.388	5.3GHz	0.163	0.55		
			Edge 1 at 0cm	0.992	5.2GHz	0.675	1.67	0.01	Case 2
			Curved surface of Edge 1 0cm	0.662	5.3GHz	0.289	0.95		
			Bottom Face at 1.3 cm	0.380	5.3GHz	0.163	0.54		
			Edge 1 at 1.5cm	0.348	5.2GHz	0.675	1.02		
			Edge 2 at 0cm	0.137			0.14		
BC0		Curved surface of Edge 1 1.5cm	0.430	5.3GHz	0.289	0.72			
		Bottom Face at 0 cm	0.742	5.3GHz	0.163	0.91			
		Edge 1 at 0cm	0.792	5.2GHz	0.675	1.47			
		Curved surface of Edge 1 0cm	0.853	5.3GHz	0.289	1.14			
		Bottom Face at 1.3 cm	0.426	5.3GHz	0.163	0.59			
		Edge 1 at 1.5cm	0.429	5.2GHz	0.675	1.10			
BC1	Edge 2 at 0cm	0.117			0.12				
	Curved surface of Edge 1 1.5cm	0.523	5.3GHz	0.289	0.81				
	Bottom Face at 0 cm	0.874	5.3GHz	0.163	1.04				
	Edge 1 at 0cm	0.969	5.2GHz	0.675	1.64	0.01	Case 3		
	Curved surface of Edge 1 0cm	1.044	5.3GHz	0.289	1.33				
	Bottom Face at 1.3 cm	0.541	5.3GHz	0.163	0.70				
BC1	Edge 1 at 1.5cm	0.665	5.2GHz	0.675	1.34				
	Edge 2 at 0cm	0.400			0.40				
	Curved surface of Edge 1 1.5cm	0.695	5.3GHz	0.289	0.98				
	Bottom Face at 0 cm	0.589	5.3GHz	0.163	0.75				
	Edge 1 at 0cm	0.874	5.2GHz	0.675	1.55				
	Curved surface of Edge 1 0cm	0.775	5.3GHz	0.289	1.06				



WWAN Band	Exposure Position	1	2		1+2 Summed SAR (W/kg)	SPLSR	Case No	
		WWAN	5.2GHz / 5.3GHz / 5.5GHz WLAN Antenna A					
		SAR (W/kg)	Band	SAR (W/kg)				
LTE	Band 17	Bottom Face at 1.3 cm	0.356	5.3GHz	0.163	0.52		
		Edge 1 at 1.5cm	0.172	5.2GHz	0.675	0.85		
		Edge 2 at 0cm	0.181			0.18		
		Curved surface of Edge 1 1.5cm	0.283	5.3GHz	0.289	0.57		
		Bottom Face at 0 cm	0.682	5.3GHz	0.163	0.85		
		Edge 1 at 0cm	0.581	5.2GHz	0.675	1.26		
	Band 13	Curved surface of Edge 1 0cm	0.763	5.3GHz	0.289	1.05		
		Bottom Face at 1.3 cm	0.312	5.3GHz	0.163	0.48		
		Edge 1 at 1.5cm	0.134	5.2GHz	0.675	0.81		
		Edge 2 at 0cm	0.085			0.09		
		Curved surface of Edge 1 1.5cm	0.238	5.3GHz	0.289	0.53		
		Bottom Face at 0 cm	0.464	5.3GHz	0.163	0.63		
	Band 5	Edge 1 at 0cm	0.471	5.2GHz	0.675	1.15		
		Curved surface of Edge 1 0cm	0.627	5.3GHz	0.289	0.92		
		Bottom Face at 1.3 cm	0.381	5.3GHz	0.163	0.54		
		Edge 1 at 1.5cm	0.331	5.2GHz	0.675	1.01		
		Edge 2 at 0cm	0.093			0.09		
		Curved surface of Edge 1 1.5cm	0.387	5.3GHz	0.289	0.68		
	Band 4	Bottom Face at 0 cm	0.622	5.3GHz	0.163	0.79		
		Edge 1 at 0cm	0.747	5.2GHz	0.675	1.42		
		Curved surface of Edge 1 0cm	0.987	5.3GHz	0.289	1.28		
		Bottom Face at 1.3 cm	0.750	5.3GHz	0.163	0.91		
		Edge 1 at 1.5cm	0.796	5.2GHz	0.675	1.47		
		Edge 2 at 0cm	0.407			0.41		
	Band 2	Curved surface of Edge 1 1.5cm	0.842	5.3GHz	0.289	1.13		
		Bottom Face at 0 cm	0.452	5.3GHz	0.163	0.62		
		Edge 1 at 0cm	1.025	5.2GHz	0.675	1.70	0.01	Case 4
		Curved surface of Edge 1 0cm	0.996	5.3GHz	0.289	1.29		
		Bottom Face at 1.3 cm	0.507	5.3GHz	0.163	0.67		
		Edge 1 at 1.5cm	0.509	5.2GHz	0.675	1.18		
	Band 25	Edge 2 at 0cm	0.343			0.34		
		Curved surface of Edge 1 1.5cm	0.529	5.3GHz	0.289	0.82		
		Bottom Face at 0 cm	0.747	5.3GHz	0.163	0.91		
		Edge 1 at 0cm	1.056	5.2GHz	0.675	1.73	0.01	Case 5
		Curved surface of Edge 1 0cm	0.938	5.3GHz	0.289	1.23		
		Bottom Face at 1.3 cm	0.406	5.3GHz	0.163	0.57		
Band 25	Edge 1 at 1.5cm	0.433	5.2GHz	0.675	1.11			
	Edge 2 at 0cm	0.313			0.31			
	Curved surface of Edge 1 1.5cm	0.469	5.3GHz	0.289	0.76			
	Bottom Face at 0 cm	0.654	5.3GHz	0.163	0.82			
	Edge 1 at 0cm	1.073	5.2GHz	0.675	1.75	0.01	Case 6	
	Curved surface of Edge 1 0cm	0.979	5.3GHz	0.289	1.27			



WWAN Band		Exposure Position	1	3		1+3 Summed SAR (W/kg)	SPLSR	Case No	
			WWAN	5.2GHz / 5.3GHz / 5.5GHz WLAN Antenna B					
			SAR (W/kg)	Band	SAR (W/kg)				
GSM	GSM850	Bottom Face at 1.3 cm	0.551	5.5GHz	0.262	0.81			
		Edge 1 at 1.5cm	0.490	5.5GHz	0.495	0.99			
		Edge 2 at 0cm	0.135			0.14			
		Curved surface of Edge 1 1.5cm	0.643	5.5GHz	0.592	1.24			
		Bottom Face at 0 cm	0.598	5.5GHz	0.262	0.86			
		Edge 1 at 0cm	0.761	5.5GHz	0.495	1.26			
			Curved surface of Edge 1 0cm	0.905	5.5GHz	0.592	1.50		
	GSM1900	Bottom Face at 1.3 cm	0.329	5.5GHz	0.262	0.59			
		Edge 1 at 1.5cm	0.390	5.5GHz	0.495	0.89			
		Edge 2 at 0cm	0.281			0.28			
		Curved surface of Edge 1 1.5cm	0.418	5.5GHz	0.592	1.01			
		Bottom Face at 0 cm	0.180	5.5GHz	0.262	0.44			
		Edge 1 at 0cm	1.077	5.5GHz	0.495	1.57			
			Curved surface of Edge 1 0cm	0.978	5.5GHz	0.592	1.57		
WCDMA	Band V	Bottom Face at 1.3 cm	0.356	5.5GHz	0.262	0.62			
		Edge 1 at 1.5cm	0.314	5.5GHz	0.495	0.81			
		Edge 2 at 0cm	0.091			0.09			
		Curved surface of Edge 1 1.5cm	0.433	5.5GHz	0.592	1.03			
		Bottom Face at 0 cm	0.336	5.5GHz	0.262	0.60			
		Edge 1 at 0cm	0.624	5.5GHz	0.495	1.12			
			Curved surface of Edge 1 0cm	0.900	5.5GHz	0.592	1.49		
	Band IV	Bottom Face at 1.3 cm	0.659	5.5GHz	0.262	0.92			
		Edge 1 at 1.5cm	0.741	5.5GHz	0.495	1.24			
		Edge 2 at 0cm	0.395			0.40			
		Curved surface of Edge 1 1.5cm	0.779	5.5GHz	0.592	1.37			
		Bottom Face at 0 cm	0.320	5.5GHz	0.262	0.58			
		Edge 1 at 0cm	0.909	5.5GHz	0.495	1.40			
			Curved surface of Edge 1 0cm	0.781	5.5GHz	0.592	1.37		
	Band II	Bottom Face at 1.3 cm	0.385	5.5GHz	0.262	0.65			
		Edge 1 at 1.5cm	0.458	5.5GHz	0.495	0.95			
		Edge 2 at 0cm	0.320			0.32			
		Curved surface of Edge 1 1.5cm	0.437	5.5GHz	0.592	1.03			
		Bottom Face at 0 cm	0.388	5.5GHz	0.262	0.65			
		Edge 1 at 0cm	0.992	5.5GHz	0.495	1.49			
			Curved surface of Edge 1 0cm	0.662	5.5GHz	0.592	1.25		
	CDMA	BC10	Bottom Face at 1.3 cm	0.380	5.5GHz	0.262	0.64		
			Edge 1 at 1.5cm	0.348	5.5GHz	0.495	0.84		
			Edge 2 at 0cm	0.137			0.14		
Curved surface of Edge 1 1.5cm			0.430	5.5GHz	0.592	1.02			
Bottom Face at 0 cm			0.742	5.5GHz	0.262	1.00			
Edge 1 at 0cm			0.792	5.5GHz	0.495	1.29			
			Curved surface of Edge 1 0cm	0.853	5.5GHz	0.592	1.45		
BC0		Bottom Face at 1.3 cm	0.426	5.5GHz	0.262	0.69			
		Edge 1 at 1.5cm	0.429	5.5GHz	0.495	0.92			
		Edge 2 at 0cm	0.117			0.12			
		Curved surface of Edge 1 1.5cm	0.523	5.5GHz	0.592	1.12			
		Bottom Face at 0 cm	0.874	5.5GHz	0.262	1.14			
		Edge 1 at 0cm	0.969	5.5GHz	0.495	1.46			
			Curved surface of Edge 1 0cm	1.044	5.5GHz	0.592	1.64	0.01	Case 7
BC1		Bottom Face at 1.3 cm	0.541	5.5GHz	0.262	0.80			
		Edge 1 at 1.5cm	0.665	5.5GHz	0.495	1.16			
		Edge 2 at 0cm	0.400			0.40			
		Curved surface of Edge 1 1.5cm	0.695	5.5GHz	0.592	1.29			
		Bottom Face at 0 cm	0.589	5.5GHz	0.262	0.85			
		Edge 1 at 0cm	0.874	5.5GHz	0.495	1.37			
			Curved surface of Edge 1 0cm	0.775	5.5GHz	0.592	1.37		



WWAN Band	Exposure Position	1	3		1+3 Summed SAR (W/kg)	SPLSR	Case No
		WWAN	5.2GHz / 5.3GHz / 5.5GHz WLAN Antenna B				
		SAR (W/kg)	Band	SAR (W/kg)			
LTE	Band 17	Bottom Face at 1.3 cm	0.356	5.5GHz	0.262	0.62	
		Edge 1 at 1.5cm	0.172	5.5GHz	0.495	0.67	
		Edge 2 at 0cm	0.181			0.18	
		Curved surface of Edge 1 1.5cm	0.283	5.5GHz	0.592	0.88	
		Bottom Face at 0 cm	0.682	5.5GHz	0.262	0.94	
		Edge 1 at 0cm	0.581	5.5GHz	0.495	1.08	
	Band 13	Curved surface of Edge 1 0cm	0.763	5.5GHz	0.592	1.36	
		Bottom Face at 1.3 cm	0.312	5.5GHz	0.262	0.57	
		Edge 1 at 1.5cm	0.134	5.5GHz	0.495	0.63	
		Edge 2 at 0cm	0.085			0.09	
		Curved surface of Edge 1 1.5cm	0.238	5.5GHz	0.592	0.83	
		Bottom Face at 0 cm	0.464	5.5GHz	0.262	0.73	
	Band 5	Edge 1 at 0cm	0.471	5.5GHz	0.495	0.97	
		Curved surface of Edge 1 0cm	0.627	5.5GHz	0.592	1.22	
		Bottom Face at 1.3 cm	0.381	5.5GHz	0.262	0.64	
		Edge 1 at 1.5cm	0.331	5.5GHz	0.495	0.83	
		Edge 2 at 0cm	0.093			0.09	
		Curved surface of Edge 1 1.5cm	0.387	5.5GHz	0.592	0.98	
	Band 4	Bottom Face at 0 cm	0.622	5.5GHz	0.262	0.88	
		Edge 1 at 0cm	0.747	5.5GHz	0.495	1.24	
		Curved surface of Edge 1 0cm	0.987	5.5GHz	0.592	1.58	
		Bottom Face at 1.3 cm	0.750	5.5GHz	0.262	1.01	
		Edge 1 at 1.5cm	0.796	5.5GHz	0.495	1.29	
		Edge 2 at 0cm	0.407			0.41	
	Band 2	Curved surface of Edge 1 1.5cm	0.842	5.5GHz	0.592	1.43	
		Bottom Face at 0 cm	0.452	5.5GHz	0.262	0.71	
		Edge 1 at 0cm	1.025	5.5GHz	0.495	1.52	
		Curved surface of Edge 1 0cm	0.996	5.5GHz	0.592	1.59	
		Bottom Face at 1.3 cm	0.507	5.5GHz	0.262	0.77	
		Edge 1 at 1.5cm	0.509	5.5GHz	0.495	1.00	
	Band 25	Edge 2 at 0cm	0.343			0.34	
		Curved surface of Edge 1 1.5cm	0.529	5.5GHz	0.592	1.12	
		Bottom Face at 0 cm	0.747	5.5GHz	0.262	1.01	
		Edge 1 at 0cm	1.056	5.5GHz	0.495	1.55	
		Curved surface of Edge 1 0cm	0.938	5.5GHz	0.592	1.53	
		Bottom Face at 1.3 cm	0.406	5.5GHz	0.262	0.67	
	Band 25	Edge 1 at 1.5cm	0.433	5.5GHz	0.495	0.93	
		Edge 2 at 0cm	0.313			0.31	
		Curved surface of Edge 1 1.5cm	0.469	5.5GHz	0.592	1.06	
		Bottom Face at 0 cm	0.654	5.5GHz	0.262	0.92	
		Edge 1 at 0cm	1.073	5.5GHz	0.495	1.57	
		Curved surface of Edge 1 0cm	0.979	5.5GHz	0.592	1.57	

16.2 SPLSR Evaluation and Analysis

General Note:

- SPLSR = $(SAR_1 + SAR_2)^{1.5} / (\text{min. separation distance, mm})$. If $SPLSR \leq 0.04$, simultaneously transmission SAR measurement is not necessary

Case 1	Band	Position	SAR (W/kg)	Gap (cm)	SAR peak location (m)			3D distance (mm)	Summed SAR (W/kg)	SPLSR Results	Simultaneous SAR
	GSM1900				X	Y	Z				
	WLAN5GHz	Edge 1	1.077	0	-0.00697	0.115	-0.177	179.2	1.75	0.01	Not required
	WLAN5GHz		0.675	0	0.001	-0.064	-0.18				

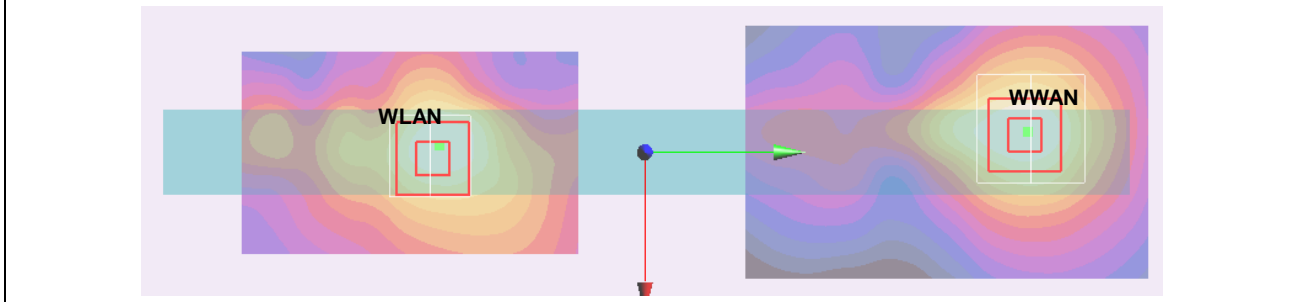

Case 2	Band	Position	SAR (W/kg)	Gap (cm)	SAR peak location (m)			3D distance (mm)	Summed SAR (W/kg)	SPLSR Results	Simultaneous SAR
	WCDMA II				X	Y	Z				
	WLAN5GHz	Edge 1	0.992	0	-0.00248	0.114	-0.176	178.1	1.67	0.01	Not required
	WLAN5GHz		0.675	0	0.001	-0.064	-0.18				

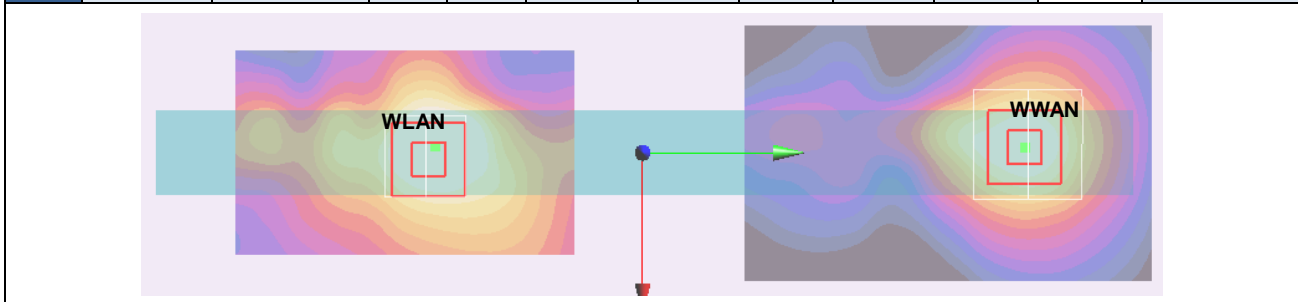

Case 3	Band	Position	SAR (W/kg)	Gap (cm)	SAR peak location (m)			3D distance (mm)	Summed SAR (W/kg)	SPLSR Results	Simultaneous SAR
	CDMA BC0				X	Y	Z				
	WLAN5GHz	Edge 1	0.969	0	-0.0055	0.082	-0.181	146.1	1.64	0.01	Not required
	WLAN5GHz		0.675	0	0.001	-0.064	-0.18				

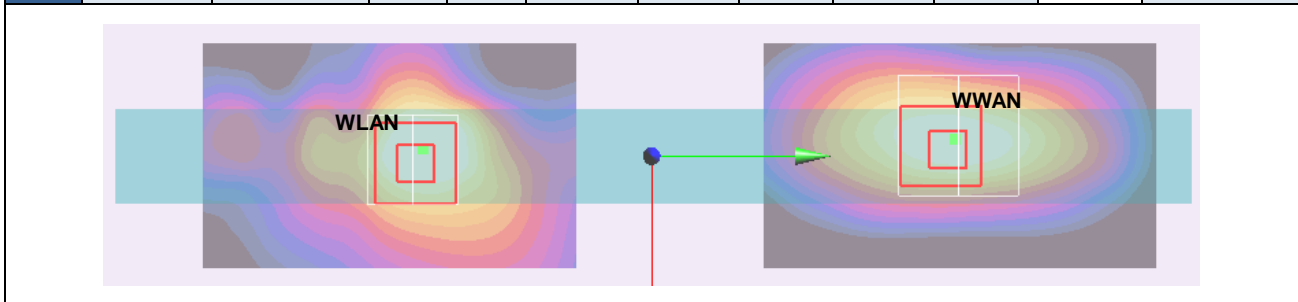

Case 4	Band	Position	SAR (W/kg)	Gap (cm)	SAR peak location (m)			3D distance (mm)	Summed SAR (W/kg)	SPLSR Results	Simultaneous SAR
					X	Y	Z				
	LTE Band 4	Edge 1	1.025	0	-0.00247	0.11	-0.178	174.0	1.70	0.01	Not required
	WLAN5GHz		0.675	0	0.001	-0.064	-0.18				

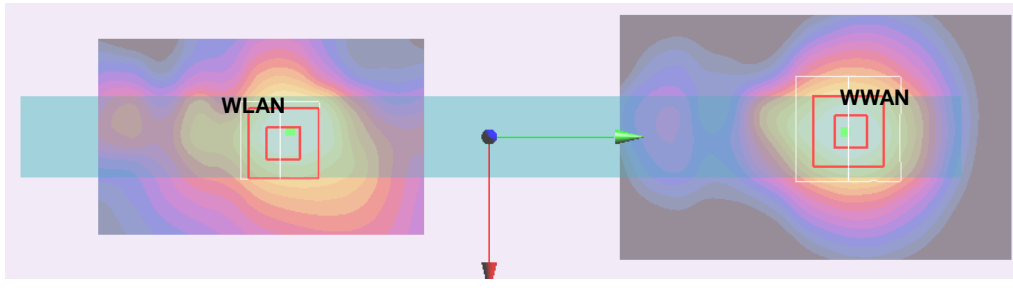

Case 5	Band	Position	SAR (W/kg)	Gap (cm)	SAR peak location (m)			3D distance (mm)	Summed SAR (W/kg)	SPLSR Results	Simultaneous SAR
					X	Y	Z				
	LTE Band 2	Edge 1	1.056	0	0.000542	0.115	-0.177	179.0	1.73	0.01	Not required
	WLAN5GHz		0.675	0	0.001	-0.064	-0.18				

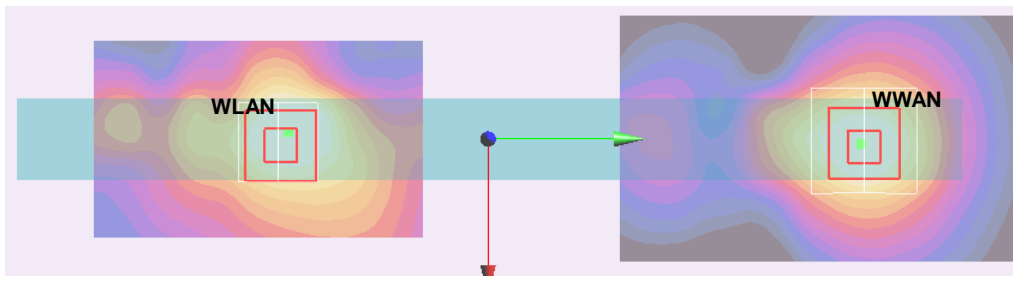

Case 6	Band	Position	SAR (W/kg)	Gap (cm)	SAR peak location (m)			3D distance (mm)	Summed SAR (W/kg)	SPLSR Results	Simultaneous SAR
					X	Y	Z				
	LTE Band 25	Edge 1	1.073	0	0.000523	0.115	-0.176	179.0	1.75	0.01	Not required
	WLAN5GHz		0.675	0	0.001	-0.064	-0.18				

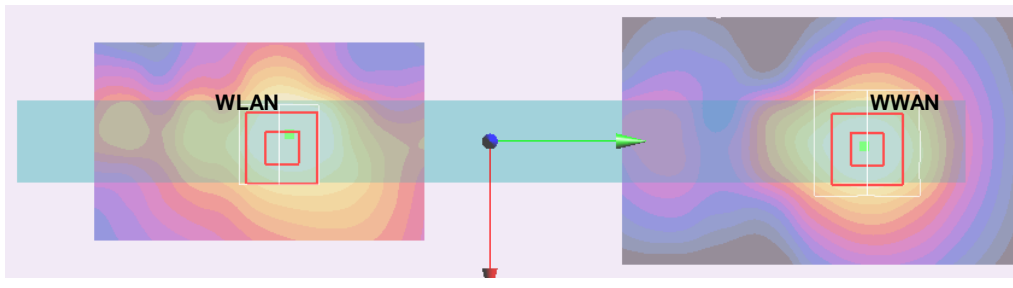

Case 7	Band	Position	SAR (W/kg)	Gap (cm)	SAR peak location (m)			3D distance (mm)	Summed SAR (W/kg)	SPLSR Results	Simultaneous SAR
					X	Y	Z				
	CDMA BC0	Curved surface of Edge 1	1.044	0	0.062	0.082	-0.178	195.8	1.64	0.01	Not required
	WLAN5GHz		0.592	0	0.08	-0.113	-0.18				

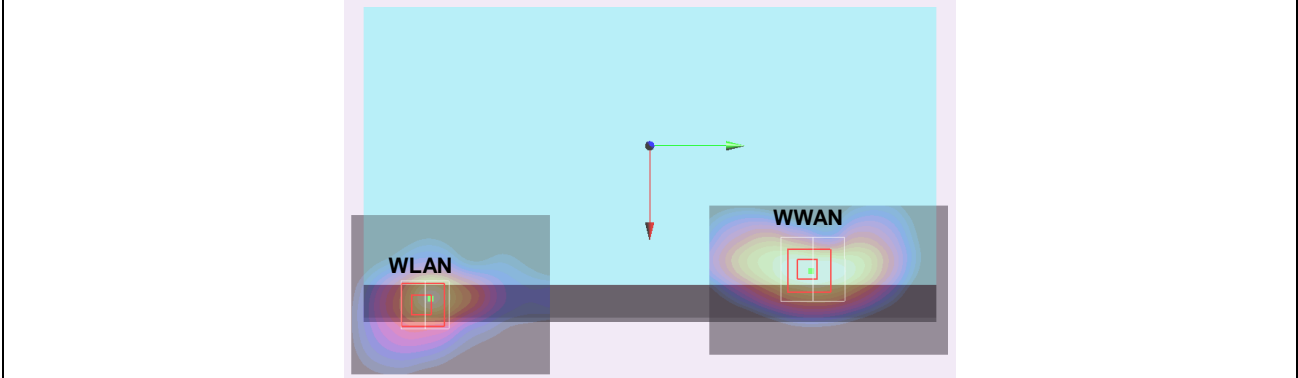

Test Engineer : Angelo Chang, Aaron Chen, Jack Wu, Frank Wu, Mood Huang, Steven Chang and Tommy Chen

17. Uncertainty Assessment

The component of uncertainty may generally be categorized according to the methods used to evaluate them. The evaluation of uncertainty by the statistical analysis of a series of observations is termed a Type A evaluation of uncertainty. The evaluation of uncertainty by means other than the statistical analysis of a series of observation is termed a Type B evaluation of uncertainty. Each component of uncertainty, however evaluated, is represented by an estimated standard deviation, termed standard uncertainty, which is determined by the positive square root of the estimated variance.

A Type A evaluation of standard uncertainty may be based on any valid statistical method for treating data. This includes calculating the standard deviation of the mean of a series of independent observations; using the method of least squares to fit a curve to the data in order to estimate the parameter of the curve and their standard deviations; or carrying out an analysis of variance in order to identify and quantify random effects in certain kinds of measurement.

A type B evaluation of standard uncertainty is typically based on scientific judgment using all of the relevant information available. These may include previous measurement data, experience, and knowledge of the behavior and properties of relevant materials and instruments, manufacture’s specification, data provided in calibration reports and uncertainties assigned to reference data taken from handbooks. Broadly speaking, the uncertainty is either obtained from an outdoor source or obtained from an assumed distribution, such as the normal distribution, rectangular or triangular distributions indicated in table below.

Uncertainty Distributions	Normal	Rectangular	Triangular	U-Shape
Multi-plying Factor ^(a)	1/k ^(b)	1/√3	1/√6	1/√2

(a) standard uncertainty is determined as the product of the multiplying factor and the estimated range of variations in the measured quantity

(b) κ is the coverage factor

Table 17.1. Standard Uncertainty for Assumed Distribution

The combined standard uncertainty of the measurement result represents the estimated standard deviation of the result. It is obtained by combining the individual standard uncertainties of both Type A and Type B evaluation using the usual “root-sum-squares” (RSS) methods of combining standard deviations by taking the positive square root of the estimated variances.

Expanded uncertainty is a measure of uncertainty that defines an interval about the measurement result within which the measured value is confidently believed to lie. It is obtained by multiplying the combined standard uncertainty by a coverage factor. Typically, the coverage factor ranges from 2 to 3. Using a coverage factor allows the true value of a measured quantity to be specified with a defined probability within the specified uncertainty range. For purpose of this document, a coverage factor two is used, which corresponds to confidence interval of about 95 %. The DASY uncertainty Budget is shown in the following tables.



Error Description	Uncertainty Value (±%)	Probability Distribution	Divisor	Ci (1g)	Ci (10g)	Standard Uncertainty (1g)	Standard Uncertainty (10g)
Measurement System							
Probe Calibration	6.0	Normal	1	1	1	± 6.0 %	± 6.0 %
Axial Isotropy	4.7	Rectangular	√3	0.7	0.7	± 1.9 %	± 1.9 %
Hemispherical Isotropy	9.6	Rectangular	√3	0.7	0.7	± 3.9 %	± 3.9 %
Boundary Effects	1.0	Rectangular	√3	1	1	± 0.6 %	± 0.6 %
Linearity	4.7	Rectangular	√3	1	1	± 2.7 %	± 2.7 %
System Detection Limits	1.0	Rectangular	√3	1	1	± 0.6 %	± 0.6 %
Readout Electronics	0.3	Normal	1	1	1	± 0.3 %	± 0.3 %
Response Time	0.8	Rectangular	√3	1	1	± 0.5 %	± 0.5 %
Integration Time	2.6	Rectangular	√3	1	1	± 1.5 %	± 1.5 %
RF Ambient Noise	3.0	Rectangular	√3	1	1	± 1.7 %	± 1.7 %
RF Ambient Reflections	3.0	Rectangular	√3	1	1	± 1.7 %	± 1.7 %
Probe Positioner	0.4	Rectangular	√3	1	1	± 0.2 %	± 0.2 %
Probe Positioning	2.9	Rectangular	√3	1	1	± 1.7 %	± 1.7 %
Max. SAR Eval.	1.0	Rectangular	√3	1	1	± 0.6 %	± 0.6 %
Test Sample Related							
Device Positioning	2.9	Normal	1	1	1	± 2.9 %	± 2.9 %
Device Holder	3.6	Normal	1	1	1	± 3.6 %	± 3.6 %
Power Drift	5.0	Rectangular	√3	1	1	± 2.9 %	± 2.9 %
Phantom and Setup							
Phantom Uncertainty	4.0	Rectangular	√3	1	1	± 2.3 %	± 2.3 %
Liquid Conductivity (Target)	5.0	Rectangular	√3	0.64	0.43	± 1.8 %	± 1.2 %
Liquid Conductivity (Meas.)	2.5	Normal	1	0.64	0.43	± 1.6 %	± 1.1 %
Liquid Permittivity (Target)	5.0	Rectangular	√3	0.6	0.49	± 1.7 %	± 1.4 %
Liquid Permittivity (Meas.)	2.5	Normal	1	0.6	0.49	± 1.5 %	± 1.2 %
Combined Standard Uncertainty						± 11.0 %	± 10.8 %
Coverage Factor for 95 %						K=2	
Expanded Uncertainty						± 22.0 %	± 21.5 %

Table 17.2. Uncertainty Budget for frequency range 300 MHz to 3 GHz



18. References

- [1] FCC 47 CFR Part 2 "Frequency Allocations and Radio Treaty Matters; General Rules and Regulations"
- [2] ANSI/IEEE Std. C95.1-1992, "IEEE Standard for Safety Levels with Respect to Human Exposure to Radio Frequency Electromagnetic Fields, 3 kHz to 300 GHz", September 1992
- [3] IEEE Std. 1528-2003, "Recommended Practice for Determining the Peak Spatial-Average Specific Absorption Rate (SAR) in the Human Head from Wireless Communications Devices: Measurement Techniques", December 2003
- [4] SPEAG DASY System Handbook
- [5] FCC KDB 447498 D01 v05r02, "Mobile and Portable Device RF Exposure Procedures and Equipment Authorization Policies", Feb 2014
- [6] FCC KDB 941225 D01 v03, "3G SAR MEAUREMENT PROCEDURES", Oct 2014
- [7] FCC KDB 941225 D05 v02r03, "SAR Evaluation Considerations for LTE Devices", Dec 2013
- [8] FCC KDB 616217 D04 v01r01, "SAR Evaluation Considerations for Laptop, Notebook, Netbook and Tablet Computers", May 2013
- [9] FCC KDB 865664 D01 v01r03, "SAR Measurement Requirements for 100 MHz to 6 GHz", Feb 2014.
- [10] FCC KDB 865664 D02 v01r01, "RF Exposure Compliance Reporting and Documentation Considerations" May 2013.