



# FCC RF Test Report

**APPLICANT** : Xplore Technologies Corp.  
**EQUIPMENT** : Wireless Modules  
**BRAND NAME** : Xplore Technologies  
**MODEL NAME** : EM7355  
**FCC ID** : Q2GEM7355  
**IC** : 4596A-EM7355  
**STANDARD** : FCC 47 CFR Part 2, 22(H), 24(E)  
**CLASSIFICATION** : PCS Licensed Transmitter (PCB)

The product was received on Nov. 20, 2013 and testing was completed on Dec. 13, 2013. We, SPORTON INTERNATIONAL INC., would like to declare that the tested sample has been evaluated in accordance with the procedures given in ANSI / TIA / EIA-603-C-2004 and shown to be compliant with the applicable technical standards.

The test results in this report apply exclusively to the tested model / sample. Without written approval of SPORTON INTERNATIONAL INC., the test report shall not be reproduced except in full.

Reviewed by: Joseph Lin / Supervisor

Approved by: Jones Tsai / Manager



## SPORTON INTERNATIONAL INC.

No. 52, Hwa Ya 1<sup>st</sup> Rd., Hwa Ya Technology Park, Kwei-Shan Hsiang, Tao Yuan Hsien, Taiwan, R.O.C.



TABLE OF CONTENTS

REVISION HISTORY..... 3
SUMMARY OF TEST RESULT ..... 4
1 GENERAL DESCRIPTION ..... 5
1.1 Applicant..... 5
1.2 Manufacturer ..... 5
1.3 Feature of Equipment Under Test..... 5
1.4 Product Specification of Equipment Under Test ..... 5
1.5 Modification of EUT ..... 6
1.6 Maximum ERP/EIRP Power..... 6
1.7 Testing Site..... 6
1.8 Applied Standards ..... 6
2 TEST CONFIGURATION OF EQUIPMENT UNDER TEST ..... 7
2.1 Test Mode..... 7
2.2 Connection Diagram of Test System ..... 8
2.3 Support Unit used in test configuration and system ..... 8
2.4 Measurement Results Explanation Example ..... 8
3 TEST RESULT ..... 9
3.1 Conducted Output Power and ERP/EIRP Measurement ..... 9
3.2 Peak-to-Average Ratio ..... 11
3.3 Occupied Bandwidth and 26dB Bandwidth Measurement ..... 16
3.4 Band Edge Measurement..... 24
3.5 Conducted Spurious Emission Measurement ..... 28
3.6 Field Strength of Spurious Radiation Measurement ..... 44
3.7 Frequency Stability Measurement..... 58
4 LIST OF MEASURING EQUIPMENT ..... 62
5 UNCERTAINTY OF EVALUATION ..... 63
APPENDIX A. SETUP PHOTOGRAPHS





## SUMMARY OF TEST RESULT

Report Section	FCC Rule	IC Rule	Description	Limit	Result	Remark
3.1	§2.1046	RSS-132 (5.4) RSS-133 (6.4)	Conducted Output Power	Reporting Only	PASS	-
3.1	§22.913(a)(2)	RSS-132(5.4) SRSP-503(5.1.3)	Effective Radiated Power	< 7 Watts	PASS	-
3.1	§24.232(c)	RSS-133 (6.4) SRSP-510(5.1.2)	Equivalent Isotropic Radiated Power	< 2 Watts	PASS	-
3.2	§24.232(d)	RSS-132 (5.4) RSS-133(6.4)	Peak-to-Average Ratio	< 13 dB	PASS	-
3.3	§2.1049 §22.917(a) §24.238(b)	RSS-GEN(4.6.1) RSS-133(6.5)	Occupied Bandwidth	Reporting Only	PASS	-
3.4	§2.1051 §22.917(a) §24.238(a)	RSS-132 (5.5) RSS-133 (6.5)	Band Edge Measurement	< 43+10log10(P[Watts])	PASS	-
3.5	§2.1051 §22.917(a) §24.238(a)	RSS-132 (5.5) RSS-133 (6.5)	Conducted Emission	< 43+10log10(P[Watts])	PASS	-
3.6	§2.1053 §22.917(a) §24.238(a)	RSS-132 (5.5) RSS-133 (6.5)	Field Strength of Spurious Radiation	< 43+10log10(P[Watts])	PASS	Under limit 12.45 dB at 1648.000 MHz
3.7	§2.1055 §22.355 §24.235	RSS-132 (5.3) RSS-133 (6.3)	Frequency Stability for Temperature & Voltage	< 2.5 ppm	PASS	-



# 1 General Description

## 1.1 Applicant

Xplore Technologies Corp.  
14000 Summit Road Suite 900, Austin, Texas, 78728 USA

## 1.2 Manufacturer

Sierra Wireless Inc.  
13811, Wireless Way, Richmond, British Columbia, Canada

## 1.3 Feature of Equipment Under Test

Product Feature	
Equipment	Wireless Modules
Brand Name	Xplore Technologies
Model Name	EM7355
FCC ID	Q2GEM7355
Installed into Rugged Tablet PC	Brand name : Xplore Technologies Corp Model name : iX104C6
EUT supports Radios application	CDMA/EV-DO/GSM/EGPRS/WCDMA/HSPA/LTE
EUT Stage	Production Unit

Remark: The above EUT's information was declared by manufacturer. Please refer to the specifications or user's manual for more detailed description.

## 1.4 Product Specification of Equipment Under Test

Product Specification subjective to this standard	
Tx Frequency	CDMA2000 BC0: 824.70 MHz ~ 848.31 MHz CDMA2000 BC1: 1851.25 MHz ~ 1908.75 MHz
Rx Frequency	CDMA2000 BC0: 869.70 MHz ~ 893.31 MHz CDMA2000 BC1: 1931.25 MHz ~ 1988.75 MHz
Maximum Output Power to Antenna	CDMA2000 BC0 : 23.73 dBm CDMA2000 BC1 : 23.65 dBm
Antenna Type	PIFA Antenna
Antenna Gain	CDMA2000 BC0 : 2.88 dBi CDMA2000 BC1 : 2.86 dBi
Type of Modulation	CDMA2000 : QPSK CDMA2000 1xEV-DO : QPSK/8PSK

## 1.5 Modification of EUT

No modifications are made to the EUT during all test items.

## 1.6 Maximum ERP/EIRP Power

FCC Rule	System	Type of Modulation	Maximum ERP/EIRP (W)	Frequency Tolerance (ppm)	Emission Designator
Part 22	CDMA2000 BC0 1xEV-DO Rev. 0	QPSK	0.28	0.0287 ppm	1M28F9W
Part 24	CDMA2000 BC1 1xEV-DO Rev. 0	QPSK	0.45	0.0112 ppm	1M28F9W

## 1.7 Testing Site

<b>Test Site</b>	SPORTON INTERNATIONAL INC.		
<b>Test Site Location</b>	No. 52, Hwa Ya 1 <sup>st</sup> Rd., Hwa Ya Technology Park, Kwei-Shan Hsiang, Tao Yuan Hsien, Taiwan, R.O.C. TEL: +886-3-327-3456 FAX: +886-3-328-4978		
<b>Test Site No.</b>	<b>Sporton Site No.</b>		<b>FCC/IC Registration No.</b>
	TH02-HY	03CH07-HY	722060/4086B-1

## 1.8 Applied Standards

According to the specifications of the manufacturer, the EUT must comply with the requirements of the following standards:

- FCC 47 CFR Part 2, 22(H), 24(E)
- ANSI / TIA / EIA-603-C-2004
- FCC KDB 971168 D01 Power Meas. License Digital Systems v02r01
- FCC KDB 412172 D01 Determining ERP and ERIP v01

**Remark:** All test items were verified and recorded according to the standards and without any deviation during the test.

## 2 Test Configuration of Equipment Under Test

### 2.1 Test Mode

During all testing, EUT is in link mode with base station emulator at maximum power level. The spurious emission measurements were carried out in semi-anechoic chamber with 3-meter test range, and EUT was rotated on three test planes to find out the worst emission.

Frequency range investigated for radiated emission is as follows:

1. 30 MHz to 9000 MHz for CDMA2000 BC0.
2. 30 MHz to 19000 MHz for CDMA2000 BC1.

Test Modes		
Band	Radiated TCs	Conducted TCs
CDMA2000 BC0	■ 1xEV-DO Rev. 0 Link Mode	■ 1xEV-DO Rev. 0 Link Mode
CDMA2000 BC1	■ 1xEV-DO Rev. 0 Link Mode	■ 1xEV-DO Rev. 0 Link Mode

**Note:** The maximum RF output power levels are 1xEV-DO Rev. 0 RTAP 153.6kbps mode for CDMA2000 BC0 and CDMA2000 BC1 on QPSK Link; only these modes were used for all tests.

The conducted power table is as follows:

Conducted Power (*Unit: dBm)						
Band	CDMA2000 BC0			CDMA2000 BC1		
Channel	1013	384	777	25	600	1175
Frequency	824.7	836.52	848.31	1851.25	1880	1908.75
1xRTT RC1 SO55	23.66	23.71	23.54	23.58	23.60	23.59
1xRTT RC3 SO55	23.55	23.71	23.50	23.61	23.56	23.58
1xEVDO RTAP 153.6kbps	23.61	23.73	23.60	23.65	23.62	23.60
1xEVDO RETAP 4096Bits	23.50	23.72	23.52	23.61	23.59	23.55

## 2.2 Connection Diagram of Test System

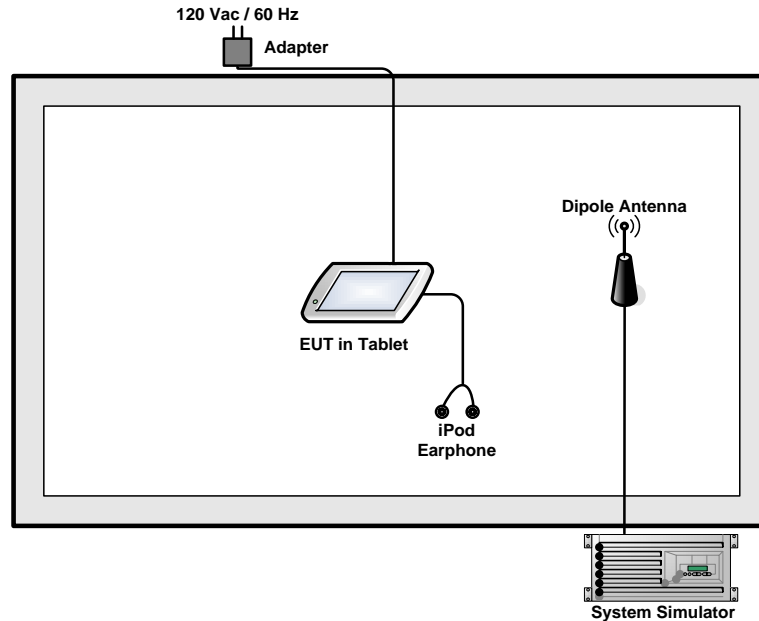

## 2.3 Support Unit used in test configuration and system

Item	Equipment	Trade Name	Model No.	FCC ID	Data Cable	Power Cord
1.	System Simulator	R&S	CMU 200	N/A	N/A	Unshielded, 1.8 m
2.	iPod Earphone	Apple	N/A	Verification	Unshielded, 1.0 m	N/A

## 2.4 Measurement Results Explanation Example

### For all conducted test items:

The offset level is set in the spectrum analyzer to compensate the RF cable loss and attenuator factor between EUT conducted output port and spectrum analyzer. With the offset compensation, the spectrum analyzer reading level is exactly the EUT RF output level.

The spectrum analyzer offset is derived from RF cable loss and attenuator factor.

*Offset = RF cable loss + attenuator factor.*

Following shows an offset computation example with cable loss 4.2 dB and 10dB attenuator.

Example :

$$\begin{aligned} \text{Offset(dB)} &= \text{RF cable loss(dB)} + \text{attenuator factor(dB)}. \\ &= 4.2 + 10 = 14.2 \text{ (dB)} \end{aligned}$$



### 3 Test Result

#### 3.1 Conducted Output Power and ERP/EIRP Measurement

##### 3.1.1 Description of the Conducted Output Power and ERP/EIRP Measurement

A base station simulator was used to establish communication with the EUT. Its parameters were set to transmit the maximum power on the EUT. The measured power in the radio frequency on the transmitter output terminals shall be reported.

The ERP of mobile transmitters must not exceed 7 Watts for CDMA2000 BC0

The EIRP of mobile transmitters must not exceed 2 Watts for CDMA2000 BC1.

According to KDB 412172 D01 Power Approach,

$EIRP = P_T + G_T - L_C$ ,  $ERP = EIRP - 2.15$ , where

$P_T$  = transmitter output power in dBm

$G_T$  = gain of the transmitting antenna in dBi

$L_C$  = signal attenuation in the connecting cable between the transmitter and antenna in dB

##### 3.1.2 Measuring Instruments

The measuring equipment is listed in the section 4 of this test report.

##### 3.1.3 Test Procedures

1. The transmitter output port was connected to base station.
2. Set EUT at maximum power through base station.
3. Select lowest, middle, and highest channels for each band and different modulation.
4. Measure maximum average power for CDMA.

##### 3.1.4 Test Setup

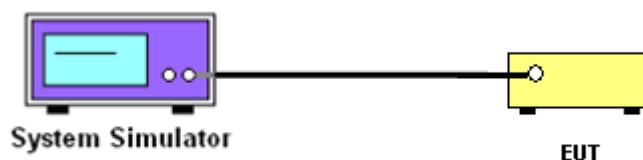

3.1.5 Test Result of Conducted Output Power and ERP/EIRP

Cellular Band ( $G_T - L_C = 2.88$ dB)			
Modes	CDMA 2000 1xEV-DO Rev. 0		
Test Status	RTAP 153.6kbps		
Channel	1013 (Low)	384 (Mid)	777 (High)
Frequency (MHz)	824.70	836.52	848.31
Conducted Power $P_T$ (dBm)	23.61	23.73	23.60
Conducted Power $P_T$ (Watts)	0.23	0.24	0.23
ERP(dBm)	24.34	24.46	24.33
ERP(Watts)	0.27	0.28	0.27

PCS Band ( $G_T - L_C = 2.86$ B)			
Modes	CDMA 2000 1xEV-DO Rev. 0		
Test Status	RTAP 153.6kbps		
Channel	25 (Low)	600 (Mid)	1175 (High)
Frequency (MHz)	1851.25	1880.00	1908.75
Conducted Power $P_T$ (dBm)	23.65	23.62	23.60
Conducted Power $P_T$ (Watts)	0.23	0.23	0.23
EIRP(dBm)	26.51	26.48	26.46
EIRP(Watts)	0.45	0.45	0.44

**Note:**

$EIRP = P_T + G_T - L_C$ ,  $ERP = EIRP - 2.15$ , where

$P_T$  = transmitter output power in dBm

$G_T$  = gain of the transmitting antenna in dBi

$L_C$  = signal attenuation in the connecting cable between the transmitter and antenna in dB

## 3.2 Peak-to-Average Ratio

### 3.2.1 Description of the PAR Measurement

The peak-to-average ratio (PAR) of the transmission may not exceed 13 dB.

### 3.2.2 Measuring Instruments

The measuring equipment is listed in the section 4 of this test report.

### 3.2.3 Test Procedures

1. The EUT was connected to Spectrum Analyzer and System Simulator via power divider.
2. Set the CCDF (Complementary Cumulative Distribution Function) option in spectrum analyzer.
3. The highest RF powers were measured and recorded the maximum PAPR level associated with a probability of 0.1 %.
4. Record the deviation as Peak to Average Ratio.

### 3.2.4 Test Setup

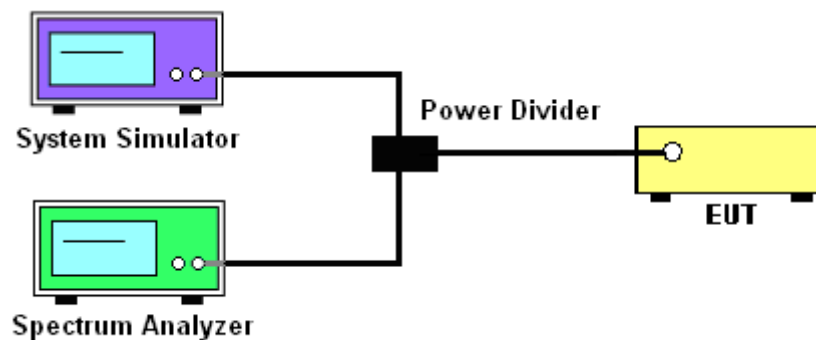

### 3.2.5 Test Result of Peak-to-Average Ratio

CDMA2000 BC0			
Modes	CDMA 2000 1xEV-DO Rev. 0		
Test Status	RTAP 153.6K		
Channel	1013 (Low)	384 (Mid)	777 (High)
Frequency (MHz)	824.70	836.52	848.31
Peak-to-Average Ratio (dB)	4.60	4.12	3.80

  

CDMA2000 BC1			
Modes	CDMA 2000 1xEV-DO Rev. 0		
Test Status	RTAP 153.6K		
Channel	25 (Low)	600 (Mid)	1175 (High)
Frequency (MHz)	1851.25	1880.00	1908.75
Peak-to-Average Ratio (dB)	3.88	3.92	3.12

### 3.2.6 Test Result (Plots) of Peak-to-Average Ratio

Band :	CDMA2000 BC0	Test Mode :	1xEV-DO Rev. 0_RTAP 153.6kbps Link (QPSK)
--------	--------------	-------------	---

Peak-to-Average Ratio on Channel 1013 (824.70 MHz)

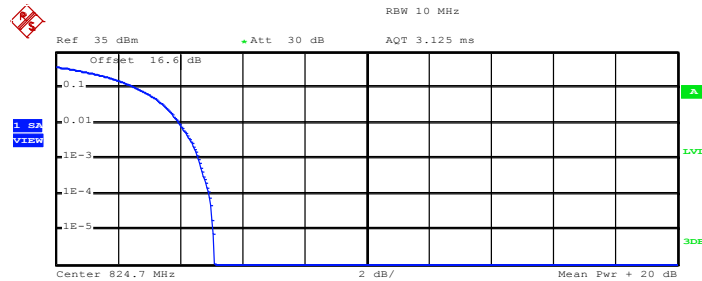

```

Complementary Cumulative Distribution Function (100000 samples)
Trace 1
Mean      23.52 dBm
Peak      28.62 dBm
Crest     5.10 dB

10 %      2.64 dB
1 %        3.96 dB
.1 %      4.60 dB
.01 %     4.96 dB
    
```

Date: 12.DEC.2013 16:47:04



Peak-to-Average Ratio on Channel 384 (836.52 MHz)

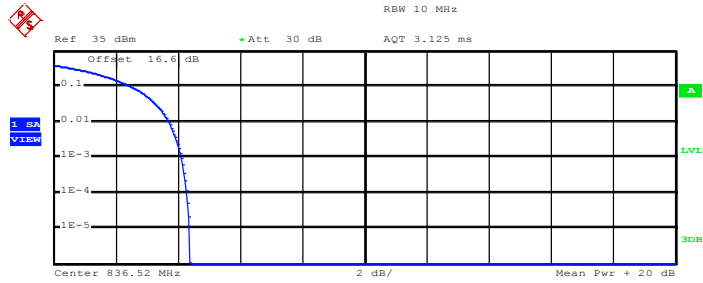

Complementary Cumulative Distribution Function (100000 samples)

Trace 1

Mean	23.31 dBm
Peak	27.70 dBm
Crest	4.39 dB
10 %	2.56 dB
1 %	3.72 dB
.1 %	4.12 dB
.01 %	4.28 dB

Date: 12.DEC.2013 16:47:50

Peak-to-Average Ratio on Channel 777 (848.31 MHz)

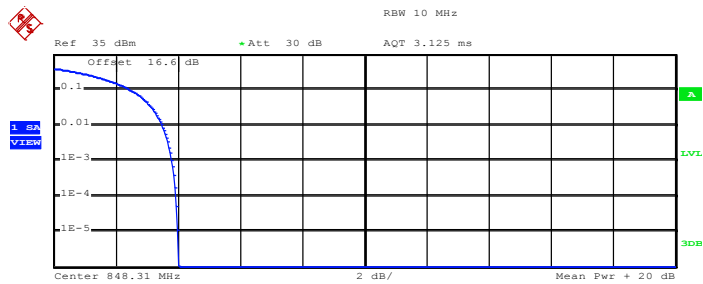

Complementary Cumulative Distribution Function (100000 samples)

Trace 1

Mean	23.14 dBm
Peak	27.14 dBm
Crest	4.00 dB
10 %	2.52 dB
1 %	3.48 dB
.1 %	3.80 dB
.01 %	3.96 dB

Date: 12.DEC.2013 16:49:41



Band :	CDMA2000 BC1	Test Mode :	1xEV-DO Rev. 0_RTAP 153.6kbps Link (QPSK)
--------	--------------	-------------	---

Peak-to-Average Ratio on Channel 25 (1851.25 MHz)

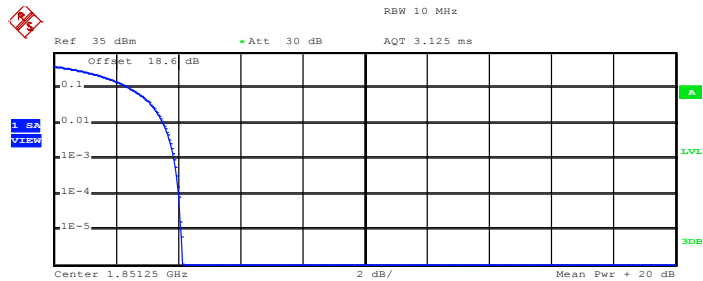

Complementary Cumulative Distribution Function (100000 samples)

Trace 1  
Mean 24.98 dBm  
Peak 29.12 dBm  
Crest 4.14 dB

10 %	2.48 dB
1 %	3.52 dB
.1 %	3.88 dB
.01 %	4.04 dB

Date: 13.DEC.2013 14:49:52

Peak-to-Average Ratio on Channel 600 (1880 MHz)

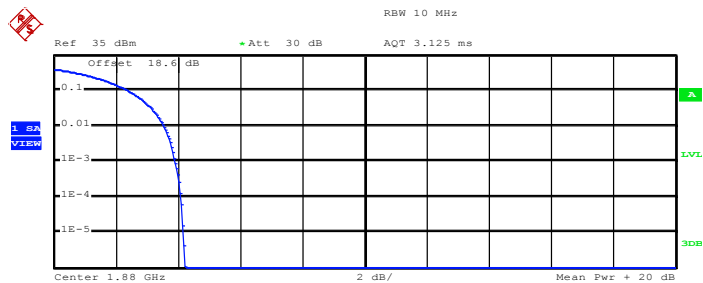

Complementary Cumulative Distribution Function (100000 samples)

Trace 1  
Mean 24.63 dBm  
Peak 28.83 dBm  
Crest 4.21 dB

10 %	2.44 dB
1 %	3.56 dB
.1 %	3.92 dB
.01 %	4.08 dB

Date: 13.DEC.2013 14:50:16



Peak-to-Average Ratio on Channel 1175 (1908.75 MHz)

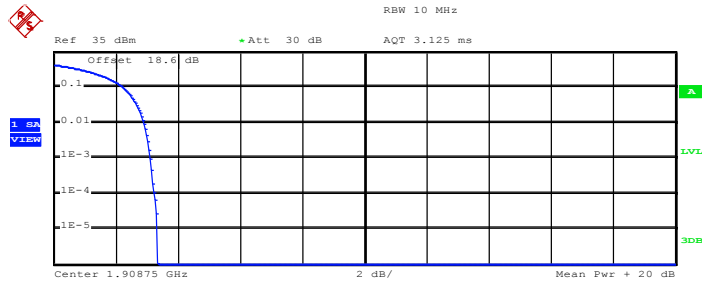

Complementary Cumulative Distribution Function (100000 samples)

Trace 1

Mean 24.86 dBm  
 Peak 28.20 dBm  
 Crest 3.34 dB

10 % 2.24 dB  
 1 % 2.92 dB  
 .1 % 3.12 dB  
 .01 % 3.24 dB

Date: 13.DEC.2013 14:50:45

### 3.3 Occupied Bandwidth and 26dB Bandwidth Measurement

#### 3.3.1 Description of Occupied Bandwidth and 26dB Bandwidth Measurement

The occupied bandwidth is the width of a frequency band such that, below the lower and above the upper frequency limits, the mean powers emitted are each equal to a specified percentage 0.5% of the total mean transmitted power.

The emission bandwidth is defined as the width of the signal between two points, located at the 2 sides of the carrier frequency, outside of which all emissions are attenuated at least 26 dB below the transmitter power.

#### 3.3.2 Measuring Instruments

The measuring equipment is listed in the section 4 of this test report.

#### 3.3.3 Test Procedures

1. The EUT was connected to Spectrum Analyzer and Base Station via power divider.
2. The RF output of EUT was connected to the spectrum analyzer by RF cable and attenuator. The path loss was compensated to the results for each measurement.
3. The 99% occupied bandwidth were measured, set RBW= 1% of span, VBW= 3\*RBW, sample detector, trace maximum hold.
4. The 26dB bandwidth were measured, set RBW= 1% of EBW, VBW= 3\*RBW, peak detector, trace maximum hold.

#### 3.3.4 Test Setup

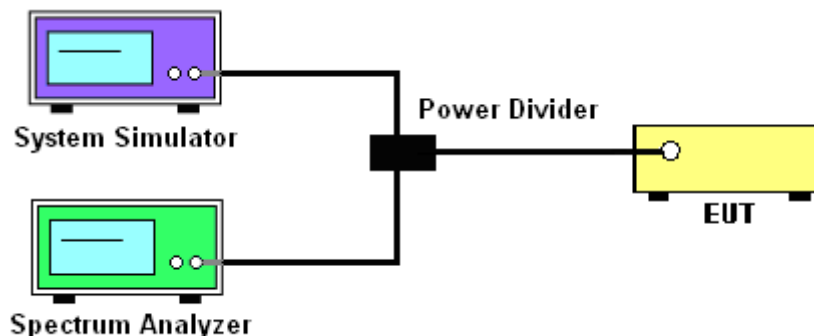





3.3.5 Test Result of Occupied Bandwidth and 26dB Bandwidth

CDMA2000 BC0			
Test Mode	CDMA 2000 1xEV-DO Rev. 0		
Test Status	RTAP 153.6K		
Channel	1013 (Low)	384 (Mid)	777 (High)
Frequency (MHz)	824.70	836.52	848.31
99% OBW (MHz)	1.27	1.27	1.28
26dB BW (MHz)	1.41	1.41	1.42

CDMA2000 BC1			
Test Mode	CDMA 2000 1xEV-DO Rev. 0		
Test Status	RTAP 153.6K		
Channel	25 (Low)	600 (Mid)	1175 (High)
Frequency (MHz)	1851.25	1880.00	1908.75
99% OBW (MHz)	1.27	1.28	1.28
26dB BW (MHz)	1.42	1.42	1.42

### 3.3.6 Test Result (Plots) of Occupied Bandwidth and 26dB Bandwidth

Band :	CDMA2000 BC0	Test Mode :	1xEV-DO Rev. 0_RTAP 153.6kbps Link (QPSK)
--------	--------------	-------------	---

99% Occupied Bandwidth Plot on Channel 1013 (824.7 MHz)

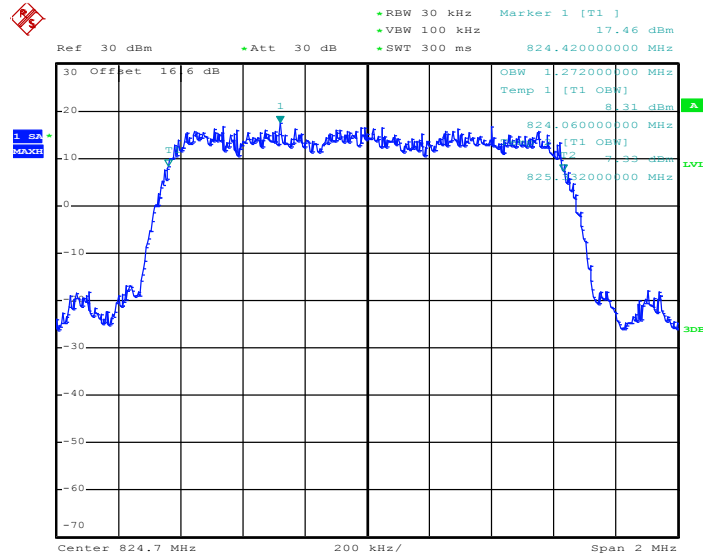

Date: 12.DEC.2013 13:15:00

26dB Bandwidth Plot on Channel 1013 (824.7 MHz)

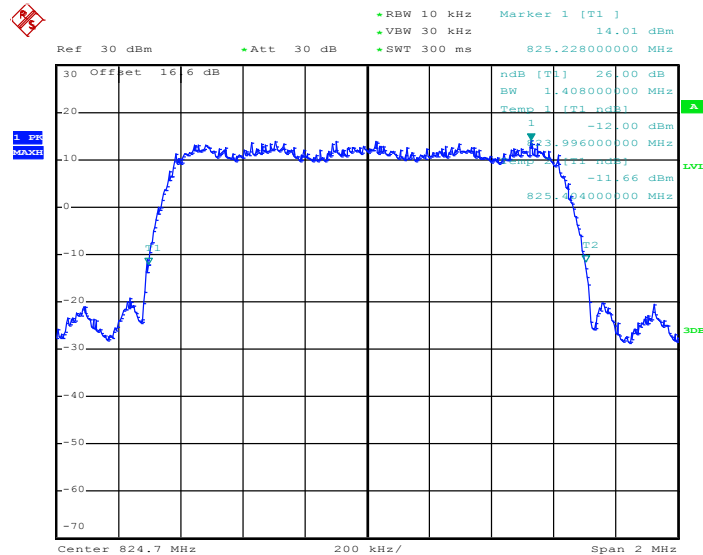

Date: 12.DEC.2013 13:13:09



99% Occupied Bandwidth Plot on Channel 384 (836.52 MHz)

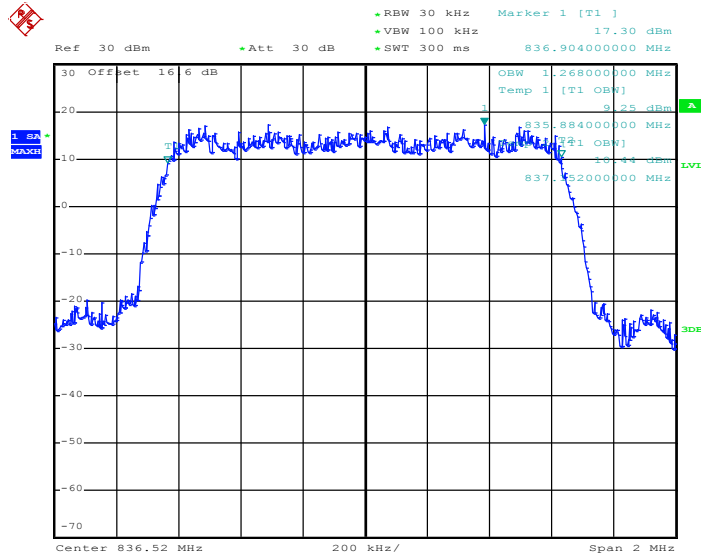

Date: 12.DEC.2013 13:15:28

26dB Bandwidth Plot on Channel 384 (836.52 MHz)

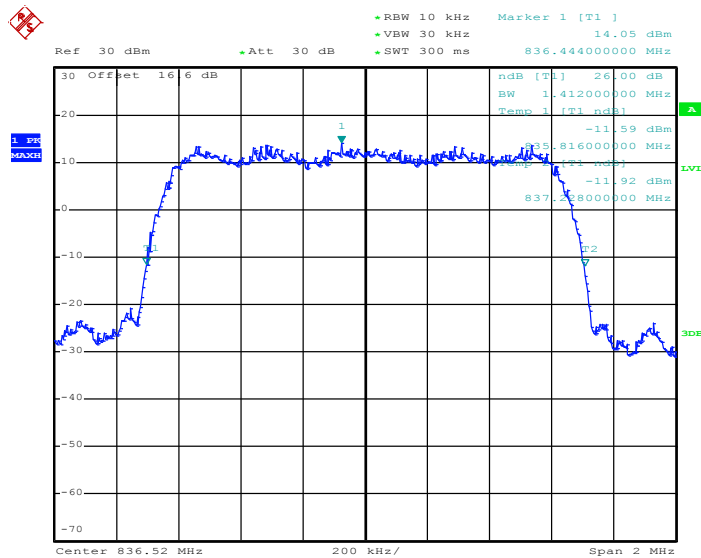

Date: 12.DEC.2013 13:13:37



99% Occupied Bandwidth Plot on Channel 777 (848.31 MHz)

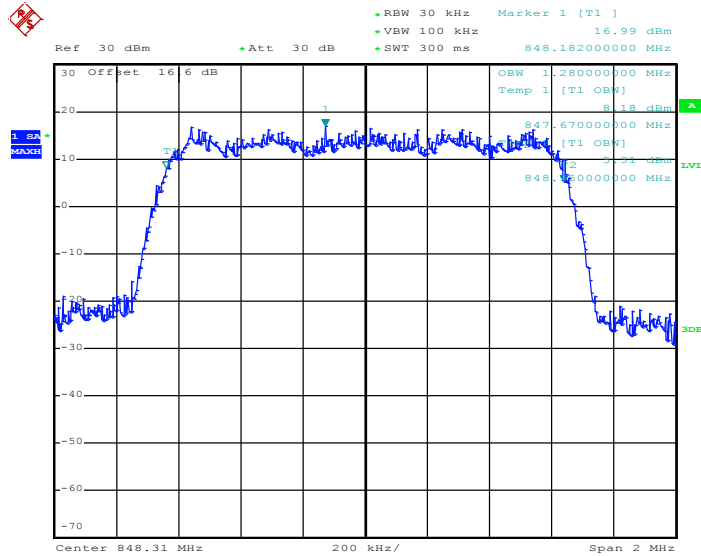

Date: 12.DEC.2013 13:15:57

26dB Bandwidth Plot on Channel 777 (848.31 MHz)

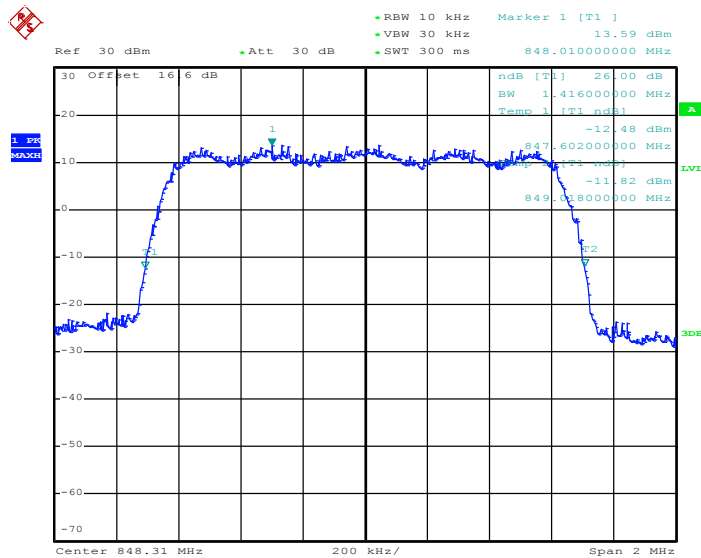

Date: 12.DEC.2013 13:14:06



Band :	CDMA2000 BC1	Test Mode :	1xEV-DO Rev. 0_RTAP 153.6kbps Link (QPSK)
--------	--------------	-------------	---

99% Occupied Bandwidth Plot on Channel 25 (1851.24 MHz)

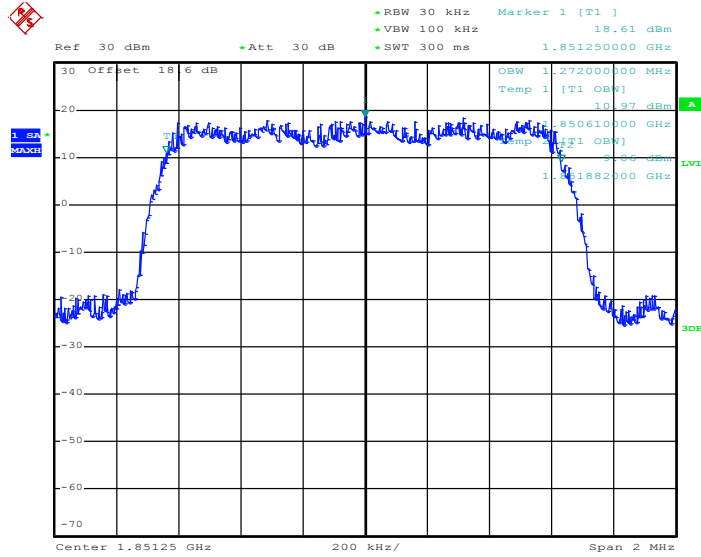

Date: 13.DEC.2013 14:04:10

26dB Bandwidth Plot on Channel 25 (1851.24 MHz)

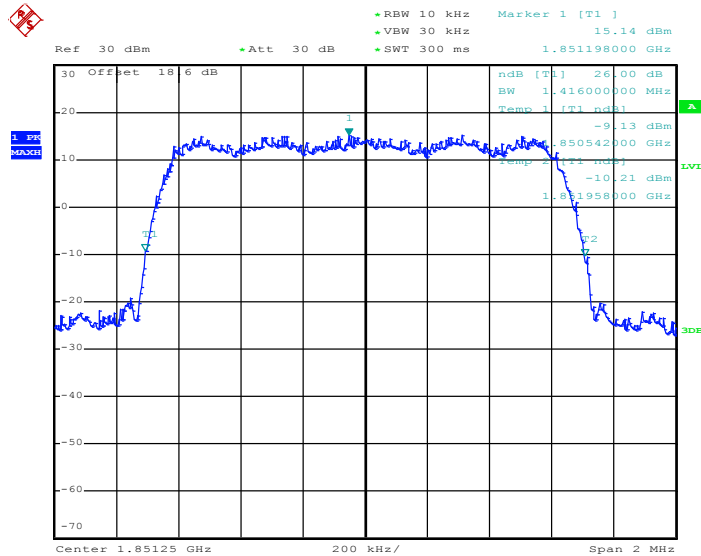

Date: 13.DEC.2013 13:59:52



99% Occupied Bandwidth Plot on Channel 600 (1880.0 MHz)

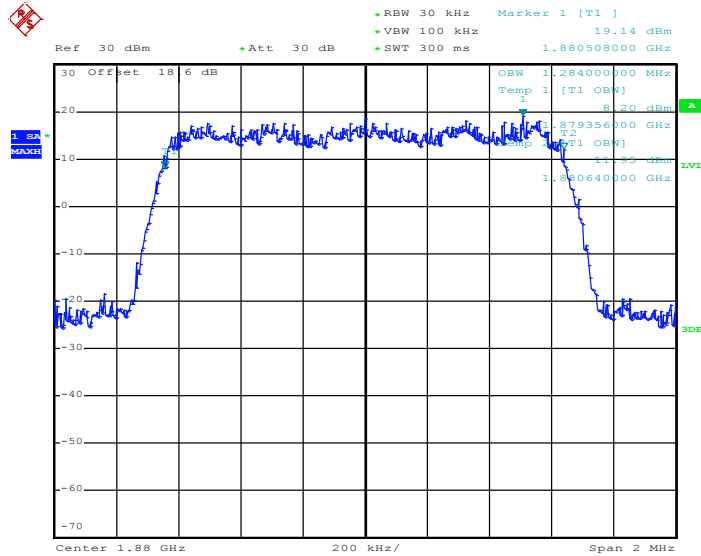

Date: 13.DEC.2013 14:04:39

26dB Bandwidth Plot on Channel 600 (1880.0 MHz)

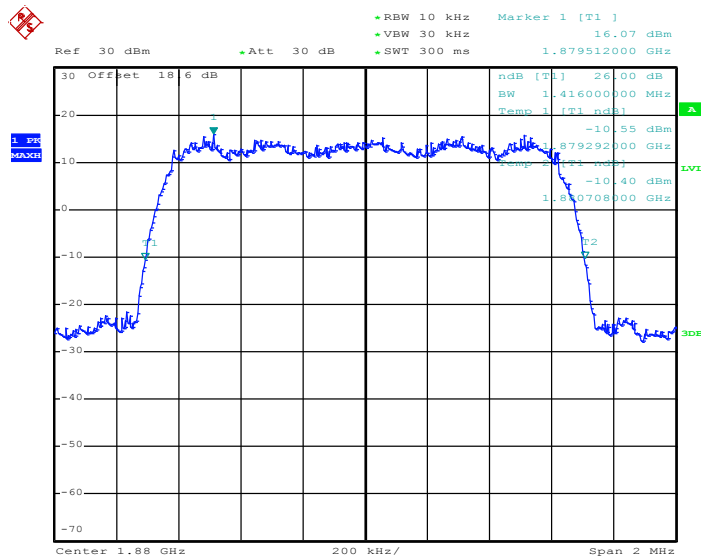

Date: 13.DEC.2013 14:00:21



99% Occupied Bandwidth Plot on Channel 1175 (1908.75 MHz)

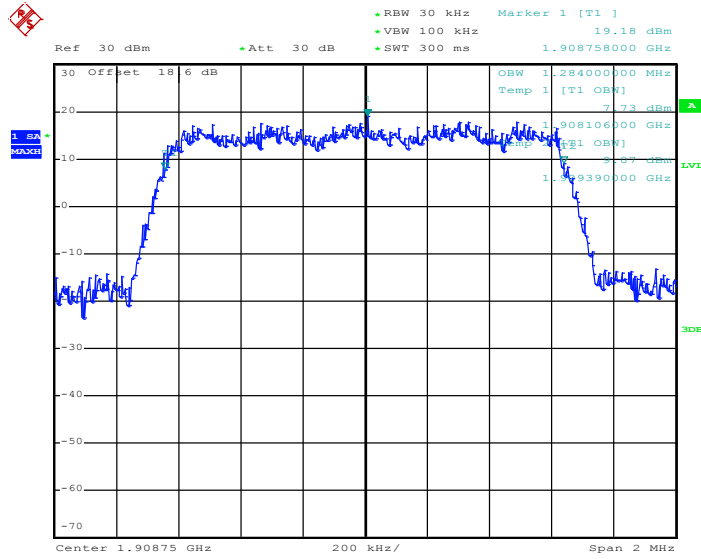

Date: 13.DEC.2013 14:05:07

26dB Bandwidth Plot on Channel 1175 (1908.75 MHz)

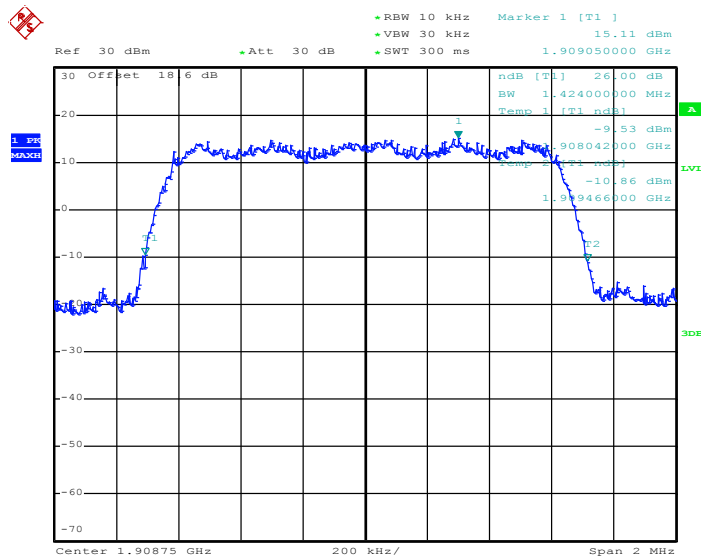

Date: 13.DEC.2013 14:00:50

## 3.4 Band Edge Measurement

### 3.4.1 Description of Band Edge Measurement

The power of any emission outside of the authorized operating frequency ranges must be lower than the transmitter power (P) by a factor of at least  $43 + 10 \log (P)$  dB.

### 3.4.2 Measuring Instruments

The measuring equipment is listed in the section 4 of this test report.

### 3.4.3 Test Procedures

5. The EUT was connected to Spectrum Analyzer and Base Station via power divider.
6. The RF output of EUT was connected to the spectrum analyzer by RF cable and attenuator. The path loss was compensated to the results for each measurement.
7. The band edges of low and high channels for the highest RF powers were measured. Setting RBW as roughly  $BW/100$ .
8. The RBW was replaced by 10 kHz, slightly smaller than the value in (2), due to the spectrum analyzer limitation to set the exact value. A worst case correction factor of  $10 \cdot \log (1\% \text{ emission-BW/measurement RBW})$  was compensated.
9. The RF fundamental frequency should be excluded against the limit line in the operating frequency band.
10. The limit line is derived from  $43 + 10 \log (P)$  dB below the transmitter power P(Watts)  
=  $P(W) - [43 + 10 \log (P)]$  (dB)  
=  $[30 + 10 \log (P)]$  (dBm) -  $[43 + 10 \log (P)]$  (dB)  
= -13dBm.



### 3.4.4 Test Setup

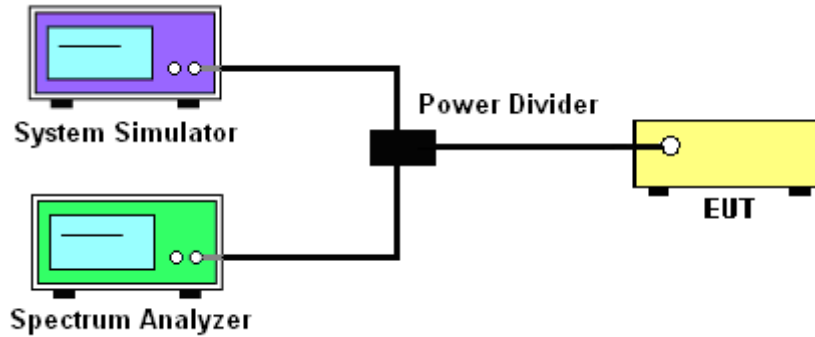



### 3.4.5 Test Result (Plots) of Conducted Band Edge

Band :	CDMA2000 BC0	Test Mode :	1xEV-DO Rev. 0_RTAP 153.6kbps Link (QPSK)
--------	--------------	-------------	---

#### Lower Band Edge Plot on Channel 1013 (824.7 MHz)

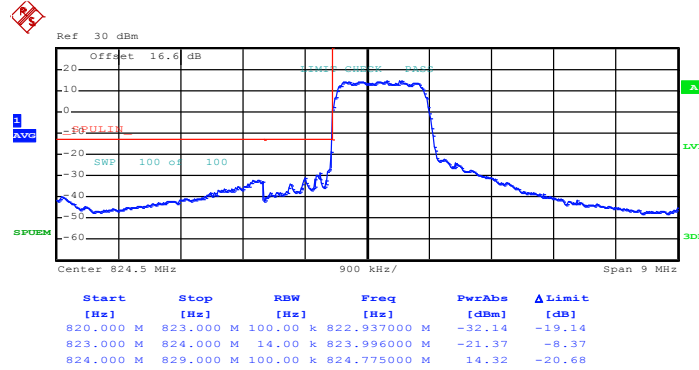

Date: 12.DEC.2013 18:12:44

#### Higher Band Edge Plot on Channel 777 (848.31 MHz)

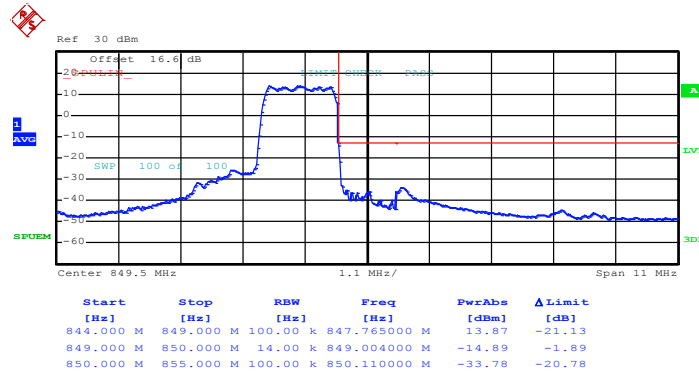

Date: 12.DEC.2013 18:34:46



Band :	CDMA2000 BC1	Test Mode :	1xEV-DO Rev. 0_RTAP 153.6kbps Link (QPSK)
--------	--------------	-------------	---

Lower Band Edge Plot on Channel 25 (1851.25 MHz)

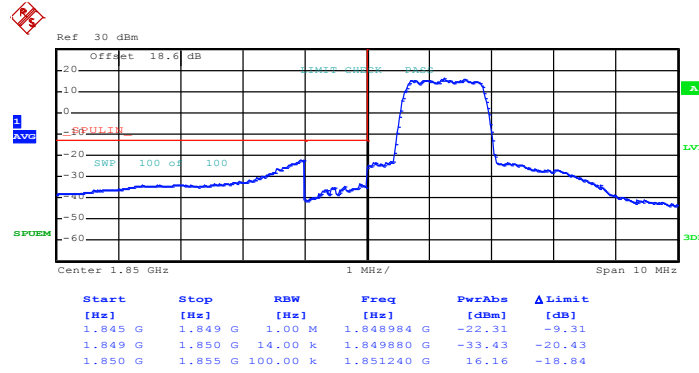

Date: 13.DEC.2013 14:32:34

Higher Band Edge Plot on Channel 1175 (1908.75 MHz)

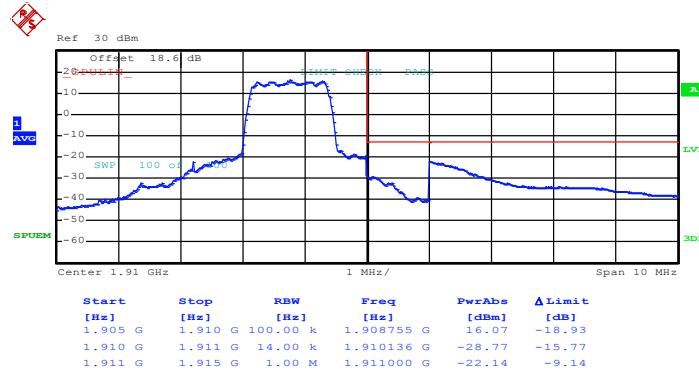

Date: 13.DEC.2013 15:05:03

### 3.5 Conducted Spurious Emission Measurement

#### 3.5.1 Description of Conducted Spurious Emission Measurement

The power of any emission outside of the authorized operating frequency ranges must be lower than the transmitter power (P) by a factor of at least  $43 + 10 \log (P)$  dB.

It is measured by means of a calibrated spectrum analyzer and scanned from 30 MHz up to a frequency including its 10<sup>th</sup> harmonic.

#### 3.5.2 Measuring Instruments

The measuring equipment is listed in the section 4 of this test report.

#### 3.5.3 Test Procedures

11. The EUT was connected to spectrum analyzer and base station via power divider.
12. The RF output of EUT was connected to the spectrum analyzer by RF cable and attenuator. The path loss was compensated to the results for each measurement.
13. The middle channel for the highest RF power within the transmitting frequency was measured.
14. The conducted spurious emission for the whole frequency range was taken.
15. The RF fundamental frequency should be excluded against the limit line in the operating frequency band.
16. The limit line is derived from  $43 + 10\log(P)$  dB below the transmitter power P(Watts)
 
$$= P(W) - [43 + 10\log(P)] \text{ (dB)}$$

$$= [30 + 10\log(P)] \text{ (dBm)} - [43 + 10\log(P)] \text{ (dB)}$$

$$= -13\text{dBm}$$

#### 3.5.4 Test Setup

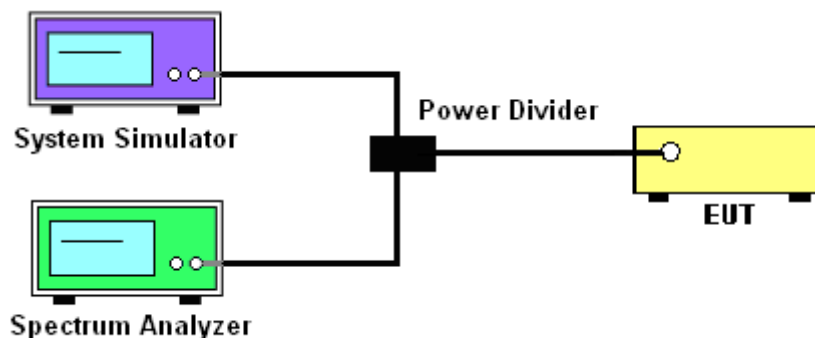

### 3.5.5 Test Result (Plots) of Conducted Spurious Emission

Band :	CDMA2000 BC0	Channel	1013
Test Mode :	1xEV-DO Rev. 0_RTAP 153.6kbps Link (QPSK)	Frequency :	824.70 MHz

Conducted Spurious Emission Plot between 30MHz ~ 1GHz

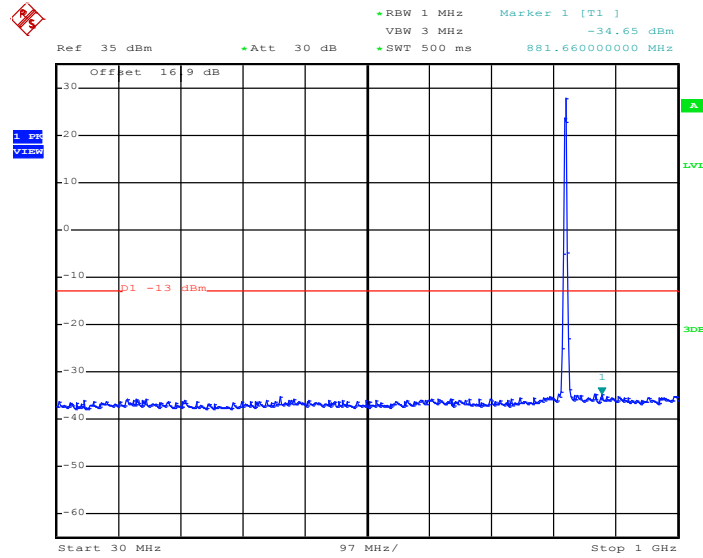

Date: 12.DEC.2013 13:57:36

Conducted Spurious Emission Plot between 1GHz ~ 3GHz

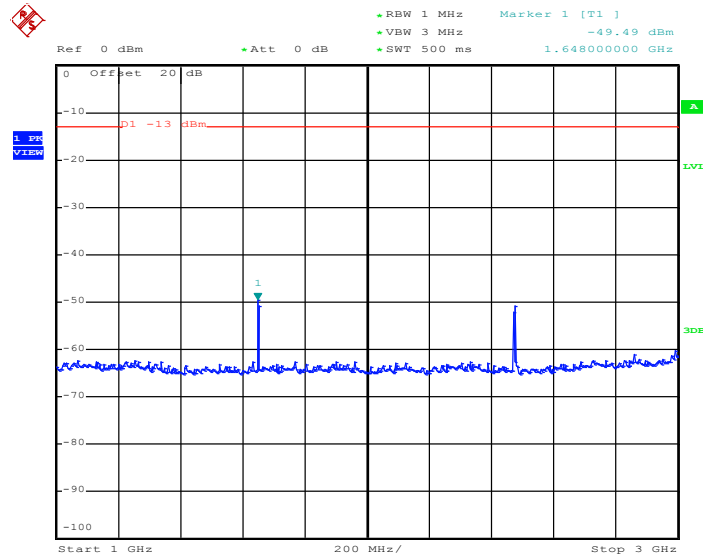

Date: 12.DEC.2013 13:57:36



### Conducted Spurious Emission Plot between 3GHz ~ 7GHz

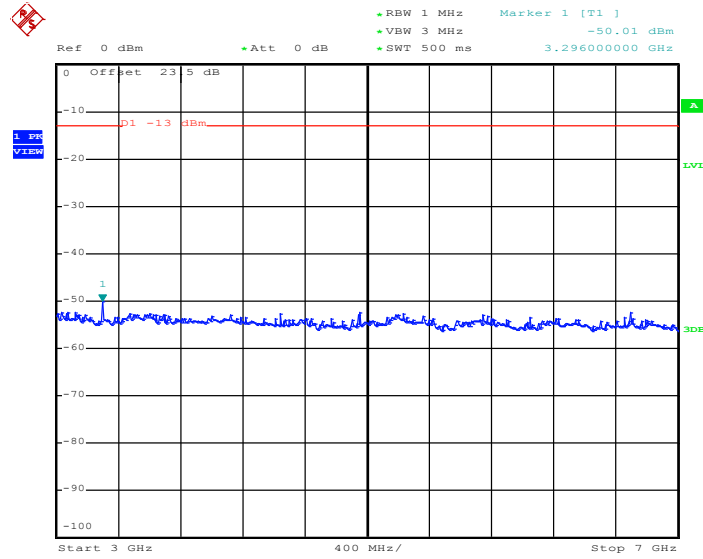

Date: 12.DEC.2013 13:57:44

### Conducted Spurious Emission Plot between 7GHz ~ 9GHz

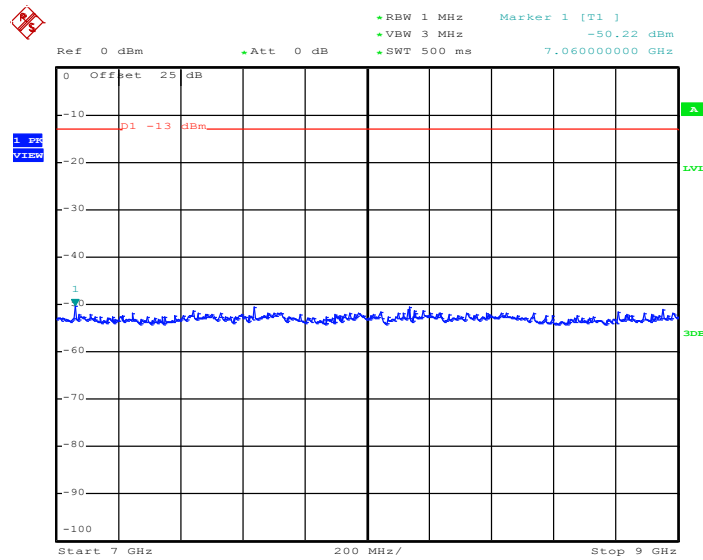

Date: 12.DEC.2013 13:57:53



Band :	CDMA2000 BC0	Channel	384
Test Mode :	1xEV-DO Rev. 0_RTAP 153.6kbps Link (QPSK)	Frequency :	836.52 MHz

Conducted Spurious Emission Plot between 30MHz ~ 1GHz

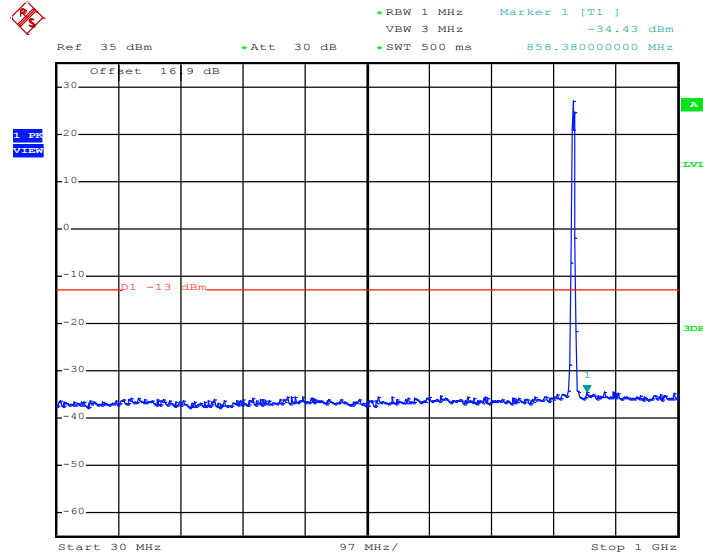

Date: 12.DEC.2013 13:24:44

Conducted Spurious Emission Plot between 1GHz ~ 3GHz

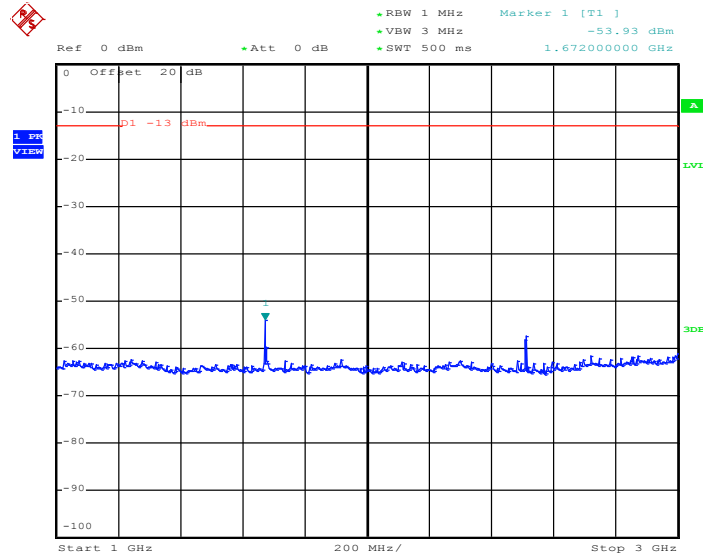

Date: 12.DEC.2013 13:20:55



### Conducted Spurious Emission Plot between 3GHz ~ 7GHz

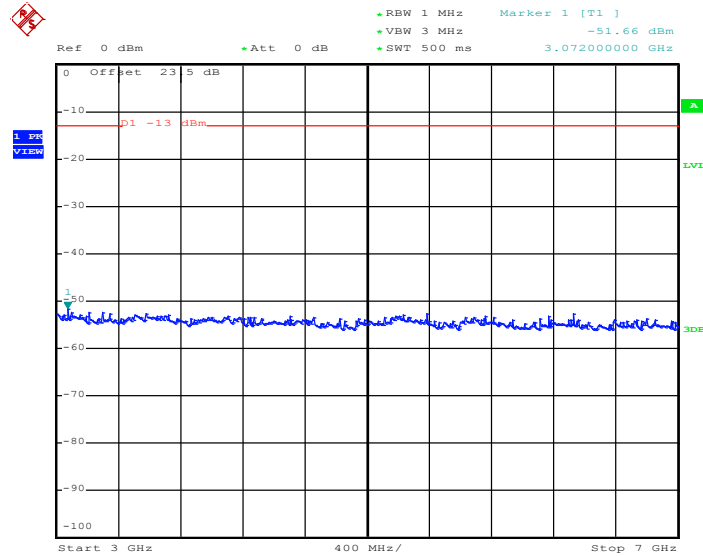

Date: 12.DEC.2013 13:21:03

### Conducted Spurious Emission Plot between 7GHz ~ 9GHz

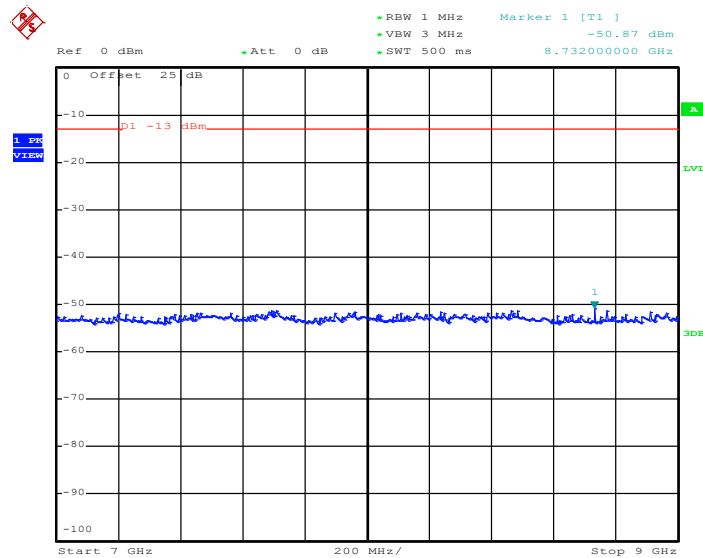

Date: 12.DEC.2013 13:21:12





Band :	CDMA2000 BC0	Channel	777
Test Mode :	1xEV-DO Rev. 0_RTAP 153.6kbps Link (QPSK)	Frequency :	848.31 MHz

Conducted Spurious Emission Plot between 30MHz ~ 1GHz

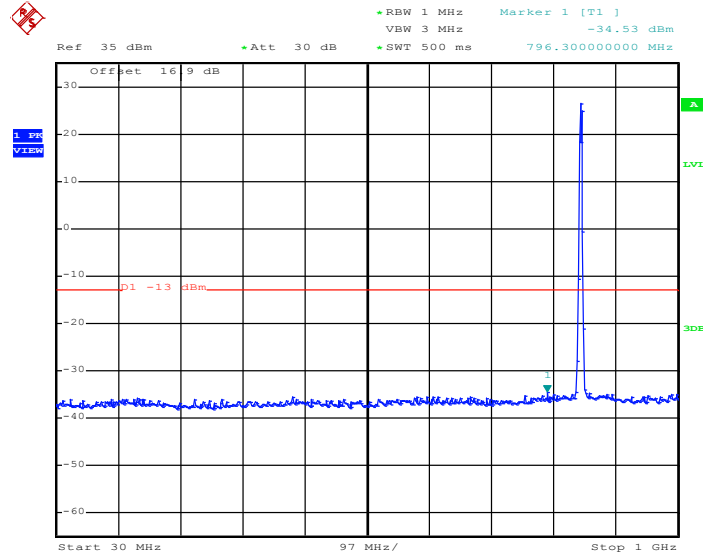

Date: 12.DEC.2013 16:43:11

Conducted Spurious Emission Plot between 1GHz ~ 3GHz

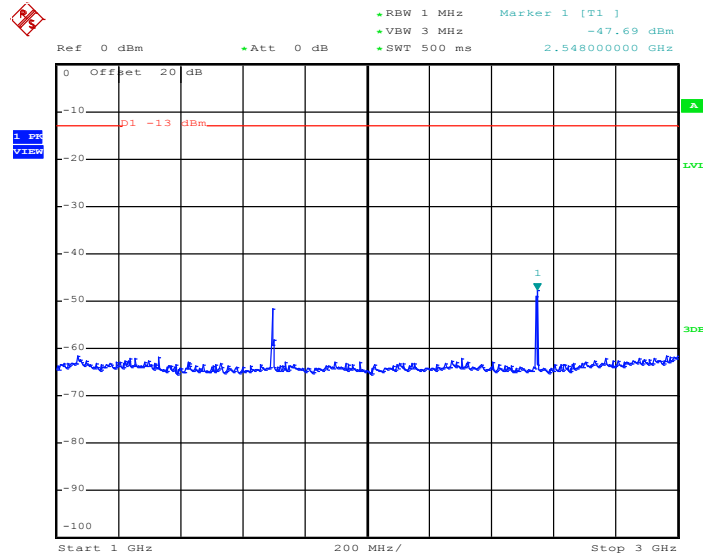

Date: 12.DEC.2013 16:40:08



### Conducted Spurious Emission Plot between 3GHz ~ 7GHz

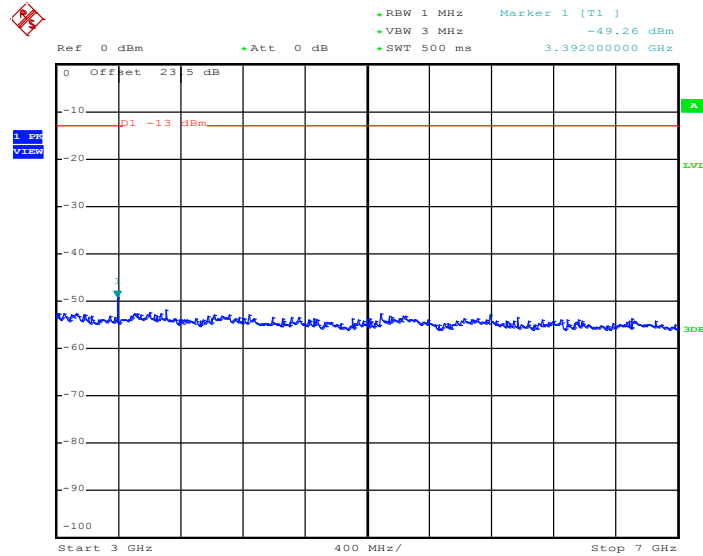

Date: 12.DEC.2013 16:40:16

### Conducted Spurious Emission Plot between 7GHz ~ 9GHz

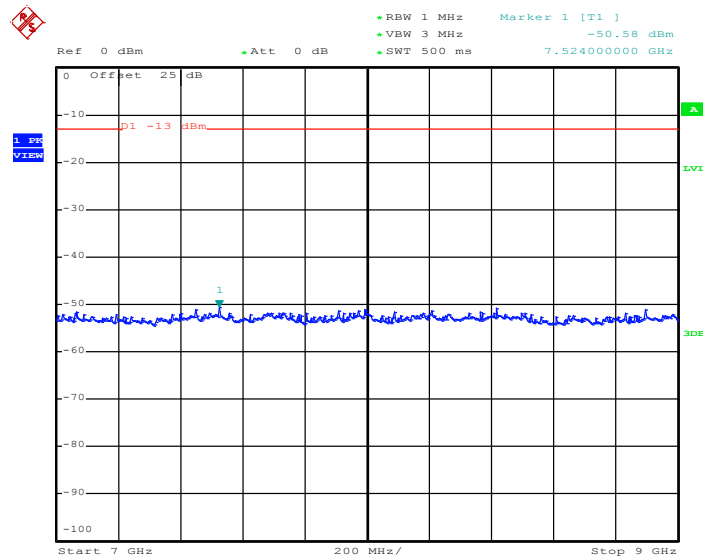

Date: 12.DEC.2013 16:40:24



Band :	CDMA2000 BC1	Channel	25
Test Mode :	1xEV-DO Rev. 0_RTAP 153.6kbps Link (QPSK)	Frequency :	1851.25 MHz

Conducted Spurious Emission Plot between 30MHz ~ 1GHz

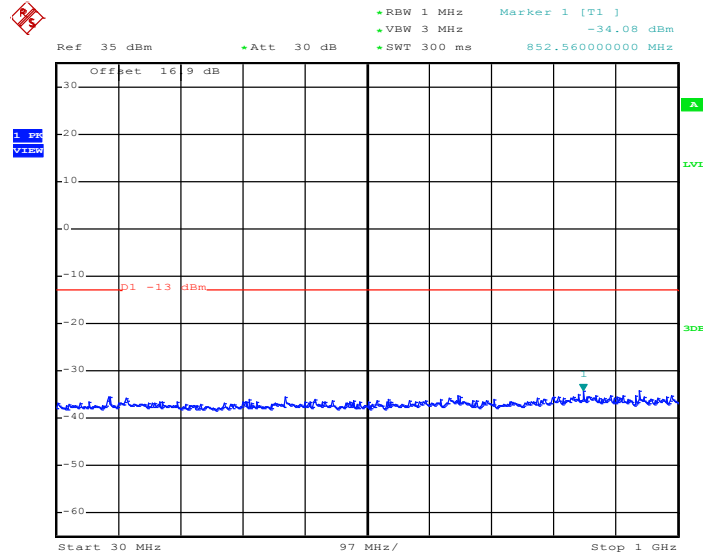

Date: 13.DEC.2013 14:12:33

Conducted Spurious Emission Plot between 1GHz ~ 3GHz

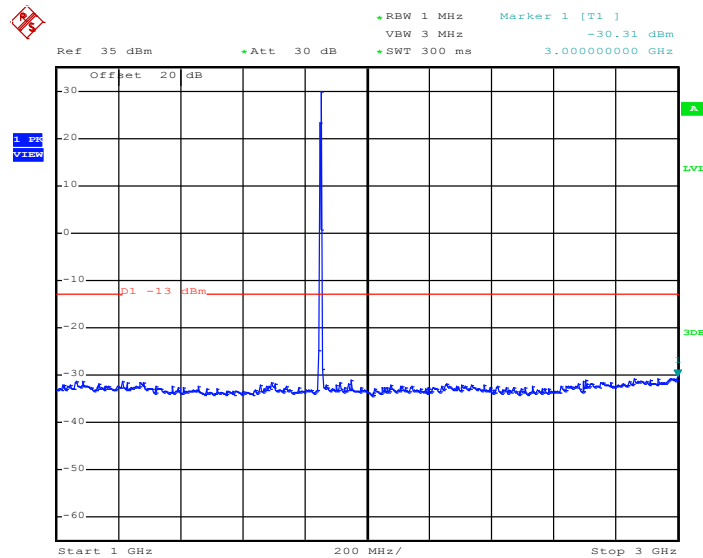

Date: 13.DEC.2013 14:17:46



Conducted Spurious Emission Plot between 3GHz ~ 7GHz

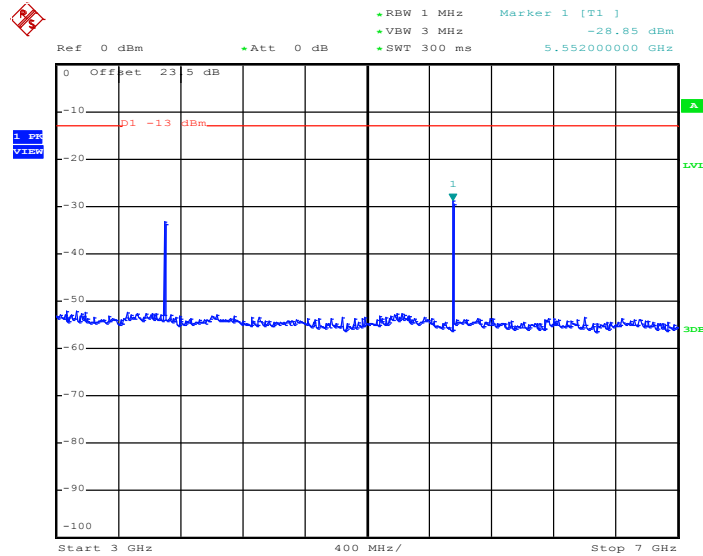

Date: 13.DEC.2013 14:12:56

Conducted Spurious Emission Plot between 7GHz ~ 13.6GHz

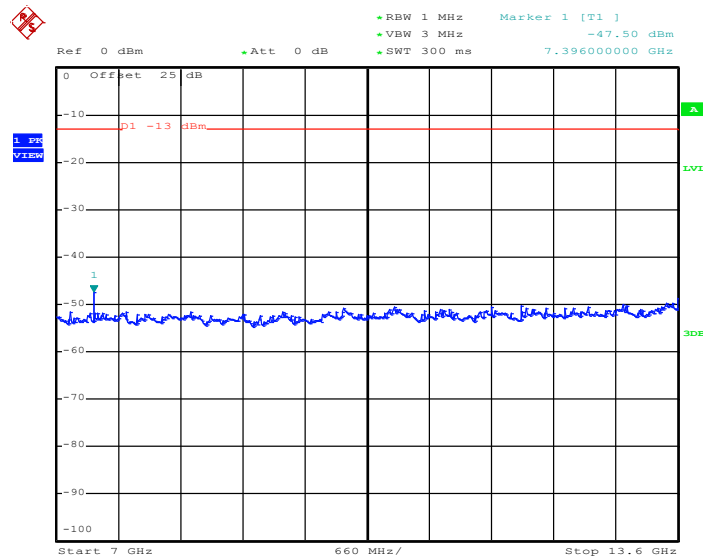

Date: 13.DEC.2013 14:13:05



Conducted Spurious Emission Plot between 13.6GHz ~ 19.1GHz

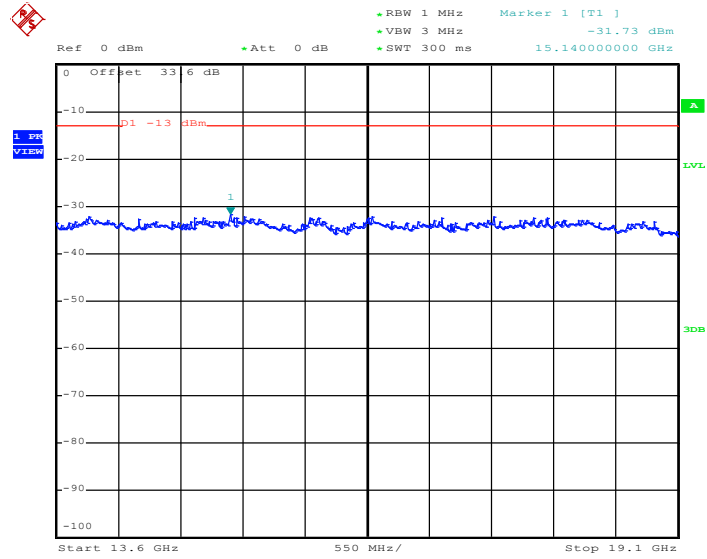

Date: 13.DEC.2013 14:13:13



Band :	CDMA2000 BC1	Channel	600
Test Mode :	1xEV-DO Rev. 0_RTAP 153.6kbps Link (QPSK)	Frequency :	1880.0 MHz

Conducted Spurious Emission Plot between 30MHz ~ 1GHz

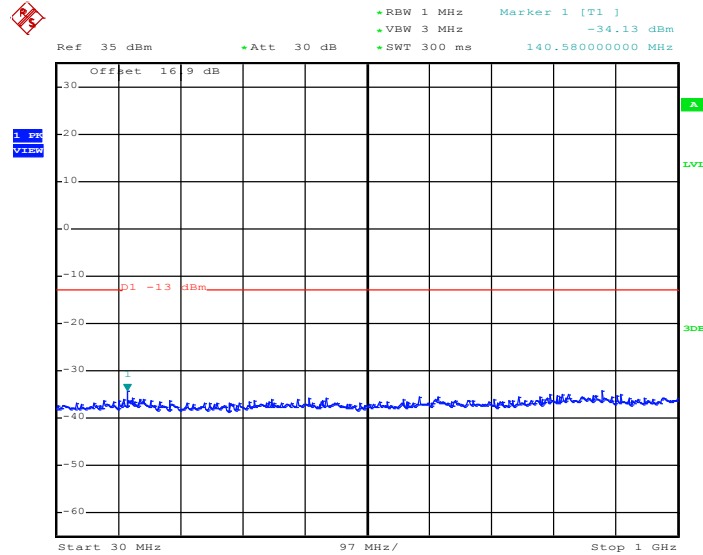

Date: 13.DEC.2013 14:06:19

Conducted Spurious Emission Plot between 1GHz ~ 3GHz

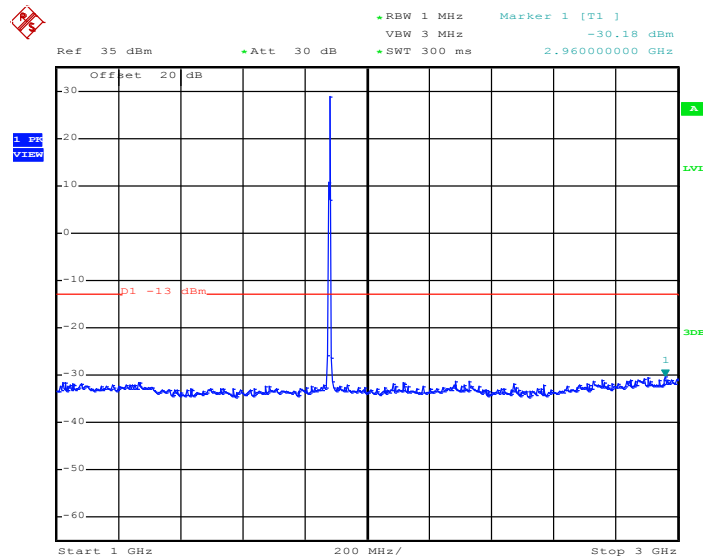

Date: 13.DEC.2013 14:10:53



### Conducted Spurious Emission Plot between 3GHz ~ 7GHz

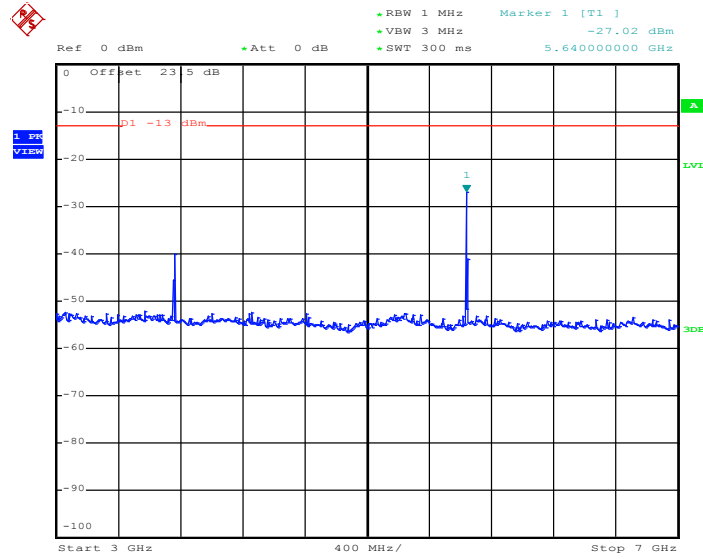

Date: 13.DEC.2013 14:06:41

### Conducted Spurious Emission Plot between 7GHz ~ 13.6GHz

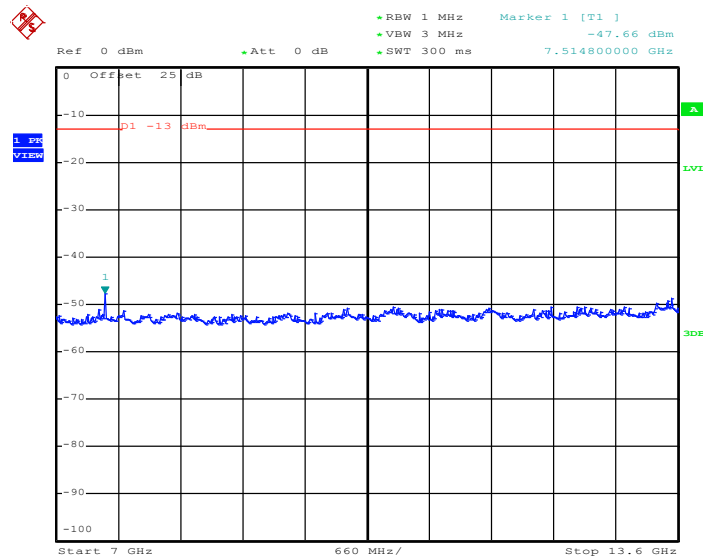

Date: 13.DEC.2013 14:06:50



Conducted Spurious Emission Plot between 13.6GHz ~ 19.1GHz

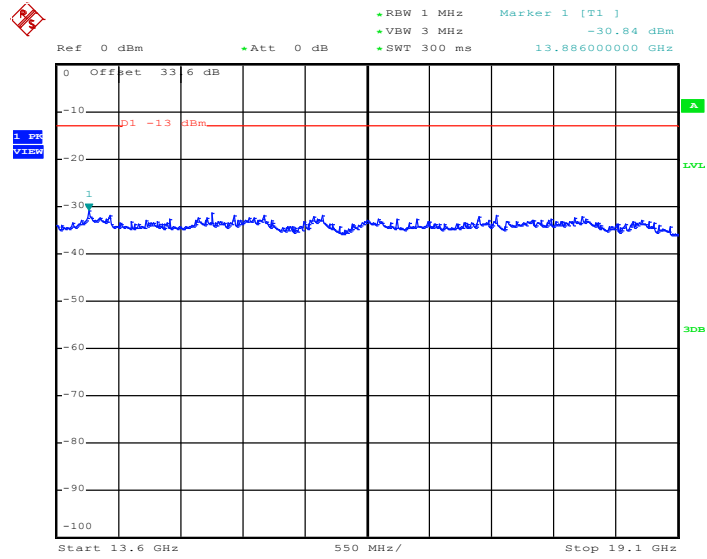

Date: 13.DEC.2013 14:06:58





Band :	CDMA2000 BC1	Channel	1175
Test Mode :	1xEV-DO Rev. 0_RTAP 153.6kbps Link (QPSK)	Frequency :	1908.75 MHz

Conducted Spurious Emission Plot between 30MHz ~ 1GHz

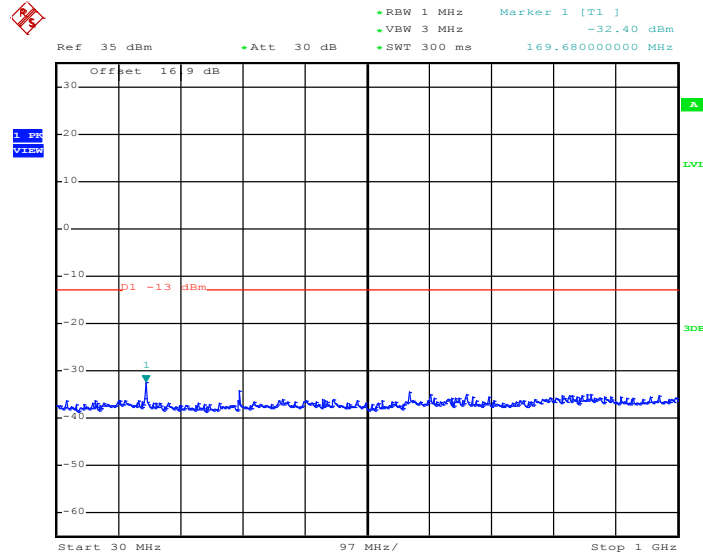

Date: 13.DEC.2013 14:20:01

Conducted Spurious Emission Plot between 1GHz ~ 3GHz

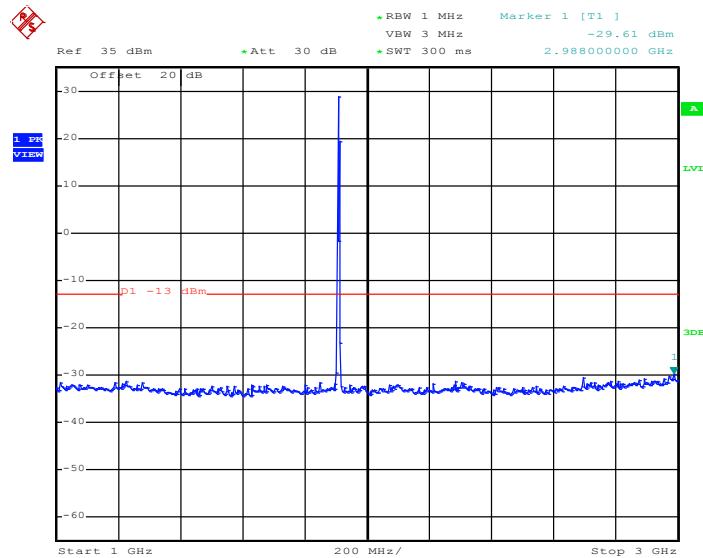

Date: 13.DEC.2013 14:23:33



### Conducted Spurious Emission Plot between 3GHz ~ 7GHz

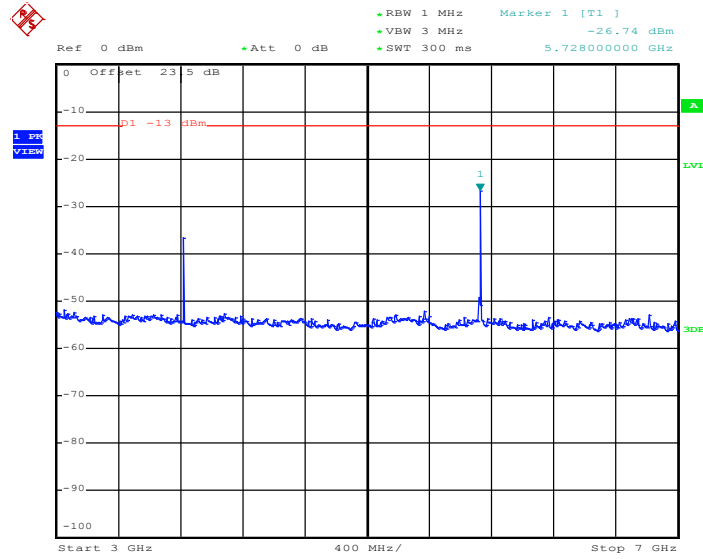

Date: 13.DEC.2013 14:20:24

### Conducted Spurious Emission Plot between 7GHz ~ 13.6GHz

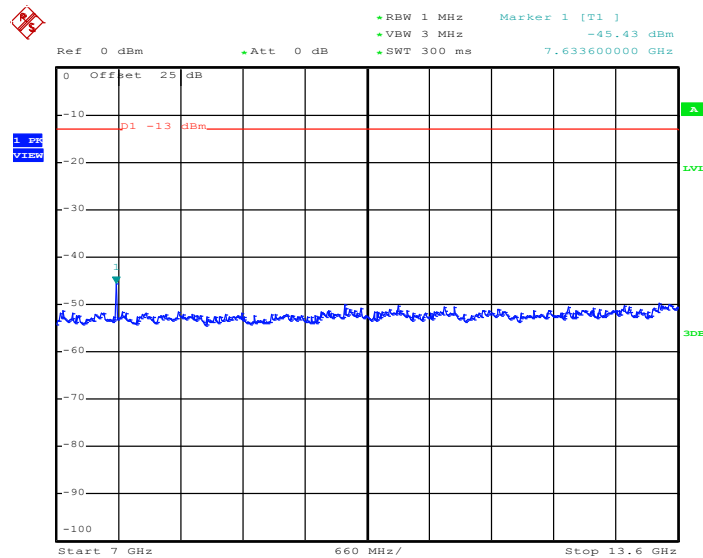

Date: 13.DEC.2013 14:20:33



Conducted Spurious Emission Plot between 13.6GHz ~ 19.1GHz

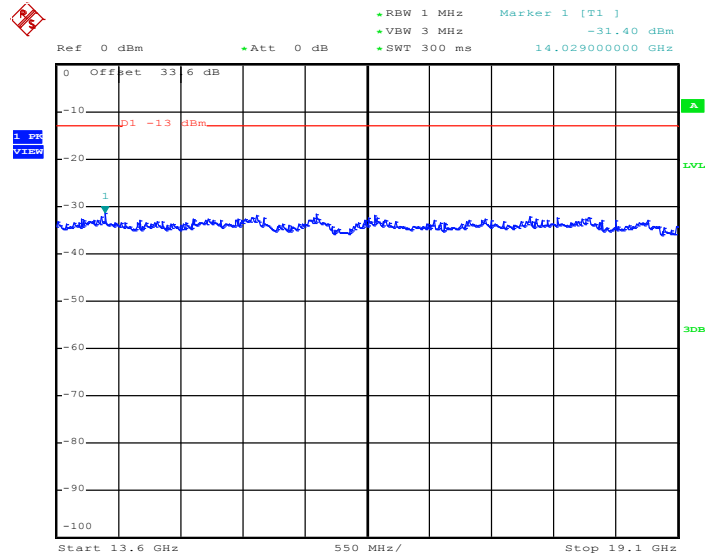

Date: 13.DEC.2013 14:20:41

## 3.6 Field Strength of Spurious Radiation Measurement

### 3.6.1 Description of Field Strength of Spurious Radiated Measurement

The power of any emission outside of the authorized operating frequency ranges must be attenuated below the transmitter power (P) by a factor of at least  $43+10\log_{10}(P[\text{Watts}])$  dB. The spectrum is scanned from 30 MHz up to a frequency including its 10th harmonic.

### 3.6.2 Measuring Instruments

The measuring equipment is listed in the section 4 of this test report.

### 3.6.3 Test Procedures

1. The EUT was placed on a rotatable wooden table with 0.8 meter above ground.
2. The EUT was set 3 meters from the receiving antenna, which was mounted on the antenna tower.
3. The table was rotated 360 degrees to determine the position of the highest spurious emission.
4. The height of the receiving antenna is varied between one meter and four meters to search the maximum spurious emission for both horizontal and vertical polarizations.
5. Make the measurement with the spectrum analyzer's RBW = 1MHz, VBW = 3MHz, taking the record of maximum spurious emission.
6. A horn antenna was substituted in place of the EUT and was driven by a signal generator.
7. Tune the output power of signal generator to the same emission level with EUT maximum spurious emission.
8. Taking the record of output power at antenna port.
9. Repeat step 7 to step 8 for another polarization.
10.  $\text{EIRP (dBm)} = \text{S.G. Power} - \text{Tx Cable Loss} + \text{Tx Antenna Gain}$
11.  $\text{ERP (dBm)} = \text{EIRP} - 2.15$
12. The RF fundamental frequency should be excluded against the limit line in the operating frequency band.
13. The limit line is derived from  $43 + 10\log(P)$  dB below the transmitter power P(Watts)  
 $= P(W) - [43 + 10\log(P)] \text{ (dB)}$   
 $= [30 + 10\log(P)] \text{ (dBm)} - [43 + 10\log(P)] \text{ (dB)}$   
 $= -13\text{dBm}.$

### 3.6.4 Test Setup

For radiated emissions from 30MHz to 1GHz

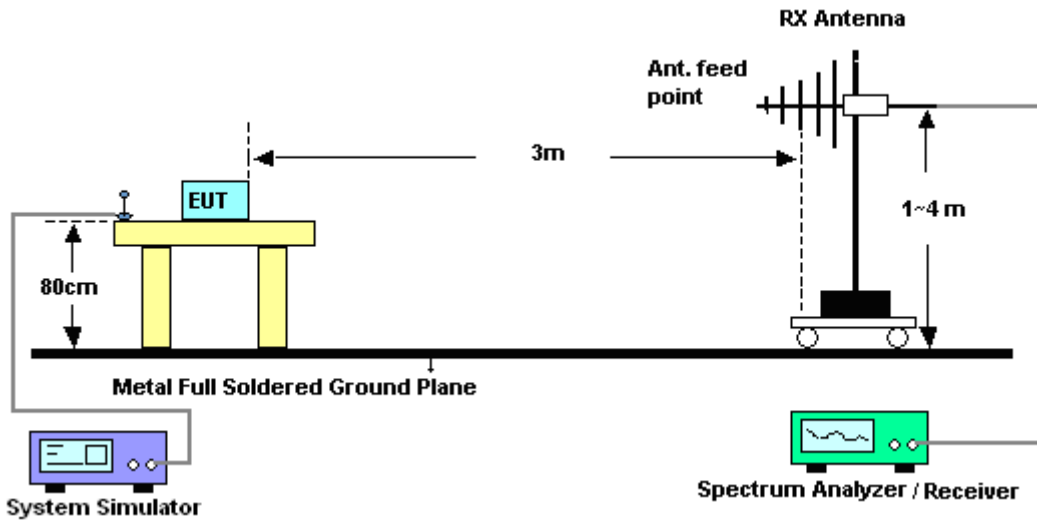

For radiated emissions above 1GHz

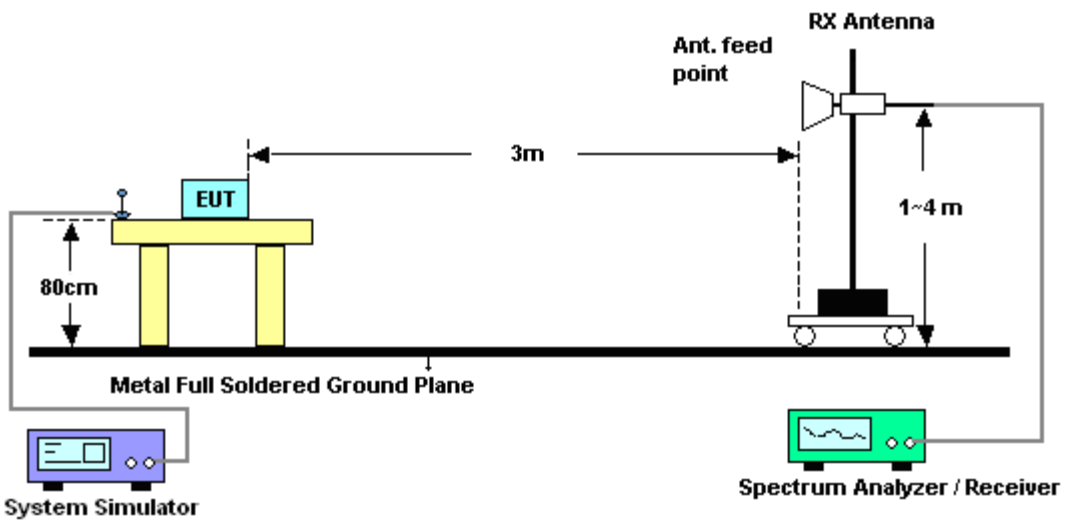



3.6.5 Test Result of Field Strength of Spurious Radiated

<Low Channel>

Band :	CDMA2000 BC0	Temperature :	21~23°C
Test Mode :	1xEV-DO Rev. 0_RTAP 153.6kbps Link (QPSK)	Relative Humidity :	53~56%
Test Engineer :	Stan Hsieh	Polarization :	Horizontal
Remark :	Spurious emissions within 30-1000MHz were found more than 20dB below limit line.		

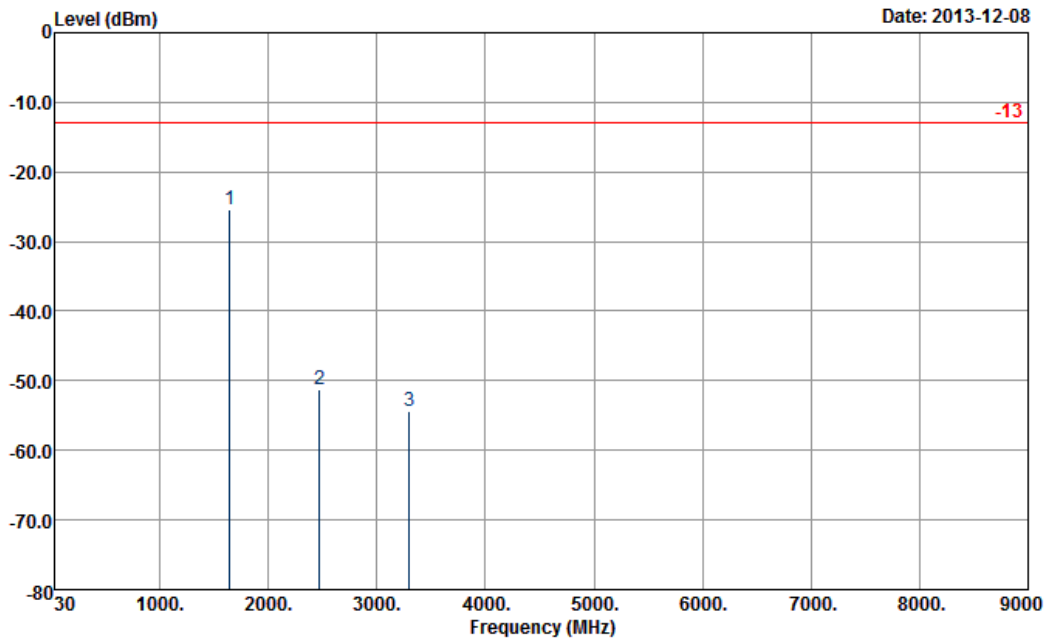

Site : 03CH07-HY  
 Condition : -13 HF-EIRP(080306) HORIZONTAL

Frequency ( MHz )	ERP ( dBm )	Limit ( dBm )	Over Limit ( dB )	SPA Reading ( dBm )	S.G. Power ( dBm )	TX Cable loss ( dB )	TX Antenna Gain ( dBi )	Polarization ( H/V )	Result
1648	-25.45	-13	-12.45	-34.3	-29.45	1.53	5.53	H	Pass
2472	-51.30	-13	-38.30	-64.39	-55.39	2.06	6.15	H	Pass
3296	-54.37	-13	-41.37	-68.18	-59.82	2.48	7.93	H	Pass



<b>Band :</b>	CDMA2000 BC0	<b>Temperature :</b>	21~23°C
<b>Test Mode :</b>	1xEV-DO Rev. 0_RTAP 153.6kbps Link (QPSK)	<b>Relative Humidity :</b>	53~56%
<b>Test Engineer :</b>	Stan Hsieh	<b>Polarization :</b>	Vertical
<b>Remark :</b>	Spurious emissions within 30-1000MHz were found more than 20dB below limit line.		

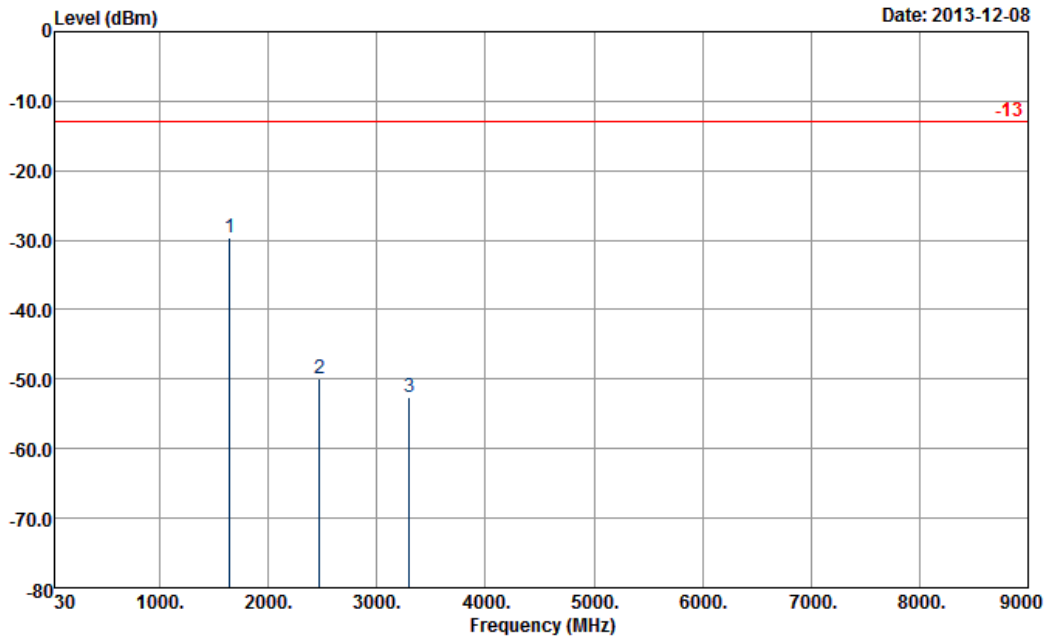

Site : 03CH07-HY  
 Condition : -13 HF-EIRP(080306) VERTICAL

Frequency ( MHz )	ERP ( dBm )	Limit ( dBm )	Over Limit ( dB )	SPA Reading ( dBm )	S.G. Power ( dBm )	TX Cable loss ( dB )	TX Antenna Gain ( dBi )	Polarization ( H/V )	Result
1648	-29.68	-13	-16.68	-40.68	-33.68	1.53	5.53	V	Pass
2472	-49.91	-13	-36.91	-63.53	-54	2.06	6.15	V	Pass
3296	-52.66	-13	-39.66	-68.3	-58.11	2.48	7.93	V	Pass



<b>Band :</b>	CDMA2000 BC1	<b>Temperature :</b>	21~23°C
<b>Test Mode :</b>	1xEV-DO Rev. 0_RTAP 153.6kbps Link (QPSK)	<b>Relative Humidity :</b>	53~56%
<b>Test Engineer :</b>	Stan Hsieh	<b>Polarization :</b>	Horizontal
<b>Remark :</b>	Spurious emissions within 30-1000MHz were found more than 20dB below limit line.		

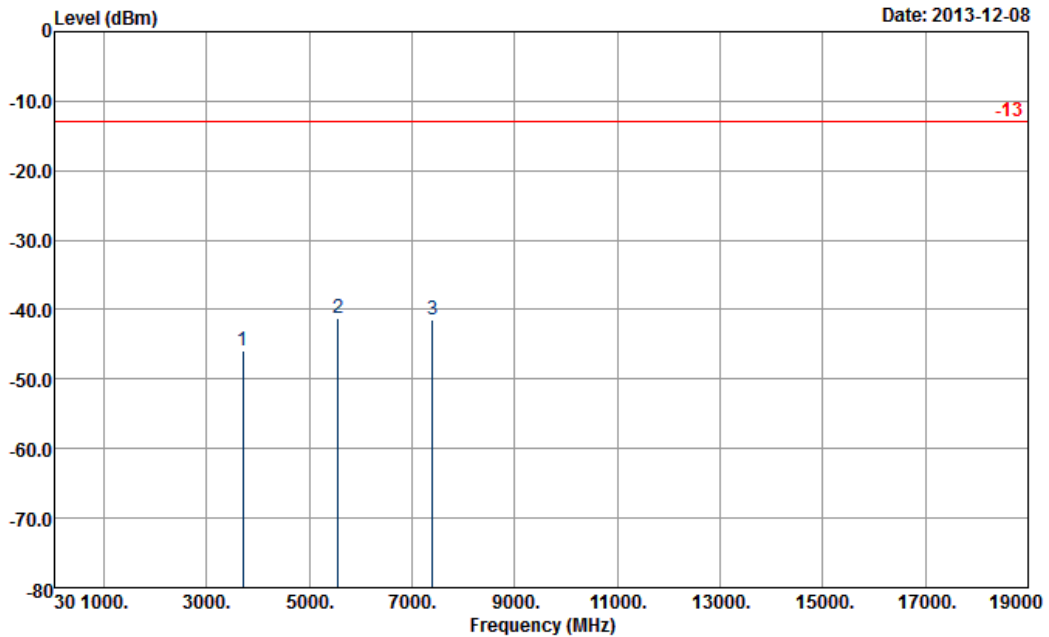

Site : 03CH07-HY  
 Condition : -13 HF-EIRP(080306) HORIZONTAL

Frequency ( MHz )	EIRP ( dBm )	Limit ( dBm )	Over Limit ( dB )	SPA Reading ( dBm )	S.G. Power ( dBm )	TX Cable loss ( dB )	TX Antenna Gain ( dBi )	Polarization ( H/V )	Result
3700	-45.85	-13	-32.85	-60.98	-52	2.59	8.74	H	Pass
5555	-41.23	-13	-28.23	-61.61	-48.89	3.04	10.70	H	Pass
7403	-41.37	-13	-28.37	-68.75	-50.11	3.28	12.02	H	Pass





<b>Band :</b>	CDMA2000 BC1	<b>Temperature :</b>	21~23°C
<b>Test Mode :</b>	1xEV-DO Rev. 0_RTAP 153.6kbps Link (QPSK)	<b>Relative Humidity :</b>	53~56%
<b>Test Engineer :</b>	Stan Hsieh	<b>Polarization :</b>	Vertical
<b>Remark :</b>	Spurious emissions within 30-1000MHz were found more than 20dB below limit line.		

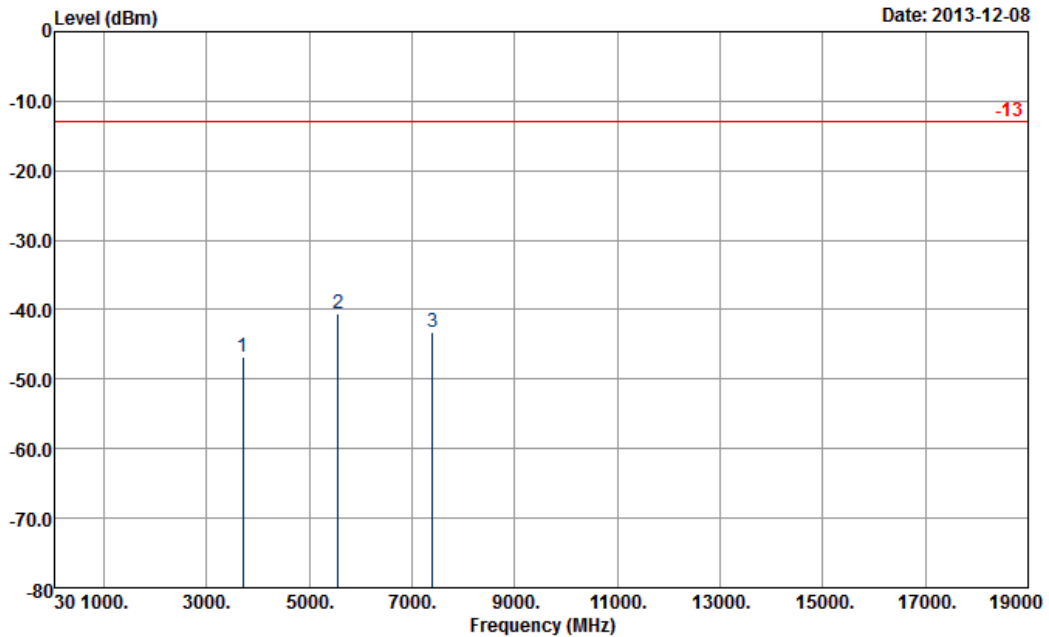

Site : 03CH07-HY  
 Condition : -13 HF-EIRP(080306) VERTICAL

Frequency ( MHz )	EIRP ( dBm )	Limit ( dBm )	Over Limit ( dB )	SPA Reading ( dBm )	S.G. Power ( dBm )	TX Cable loss ( dB )	TX Antenna Gain ( dBi )	Polarization ( H/V )	Result
3700	-46.86	-13	-33.86	-62.95	-53.01	2.59	8.74	V	Pass
5555	-40.49	-13	-27.49	-60.81	-48.15	3.04	10.70	V	Pass
7403	-43.29	-13	-30.29	-70.22	-52.03	3.28	12.02	V	Pass



<Middle Channel>

Band :	CDMA2000 BC0	Temperature :	21~23°C
Test Mode :	1xEV-DO Rev. 0_RTAP 153.6kbps Link (QPSK)	Relative Humidity :	53~56%
Test Engineer :	Stan Hsieh	Polarization :	Horizontal
Remark :	Spurious emissions within 30-1000MHz were found more than 20dB below limit line.		

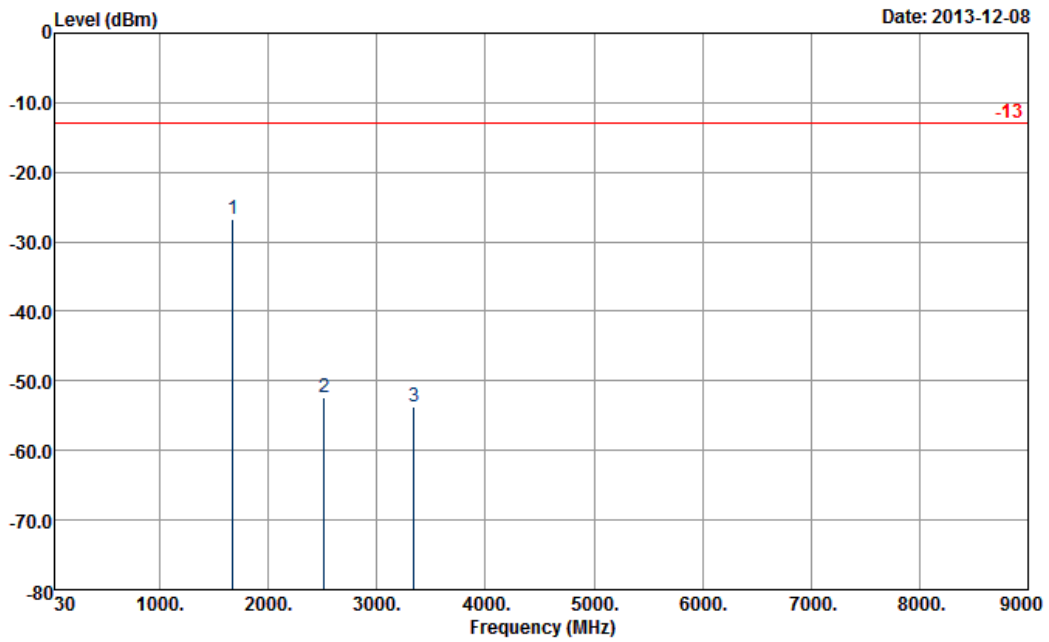

Site : 03CH07-HY  
 Condition : -13 HF-EIRP(080306) HORIZONTAL

Frequency ( MHz )	ERP ( dBm )	Limit ( dBm )	Over Limit ( dB )	SPA Reading ( dBm )	S.G. Power ( dBm )	TX Cable loss ( dB )	TX Antenna Gain ( dBi )	Polarization ( H/V )	Result
1672	-26.74	-13	-13.74	-35.64	-30.61	1.62	5.49	H	Pass
2512	-52.40	-13	-39.40	-65.68	-56.52	2.1	6.22	H	Pass
3344	-53.74	-13	-40.74	-67.89	-58.78	3.03	8.07	H	Pass



<b>Band :</b>	CDMA2000 BC0	<b>Temperature :</b>	21~23°C
<b>Test Mode :</b>	1xEV-DO Rev. 0_RTAP 153.6kbps Link (QPSK)	<b>Relative Humidity :</b>	53~56%
<b>Test Engineer :</b>	Stan Hsieh	<b>Polarization :</b>	Vertical
<b>Remark :</b>	Spurious emissions within 30-1000MHz were found more than 20dB below limit line.		

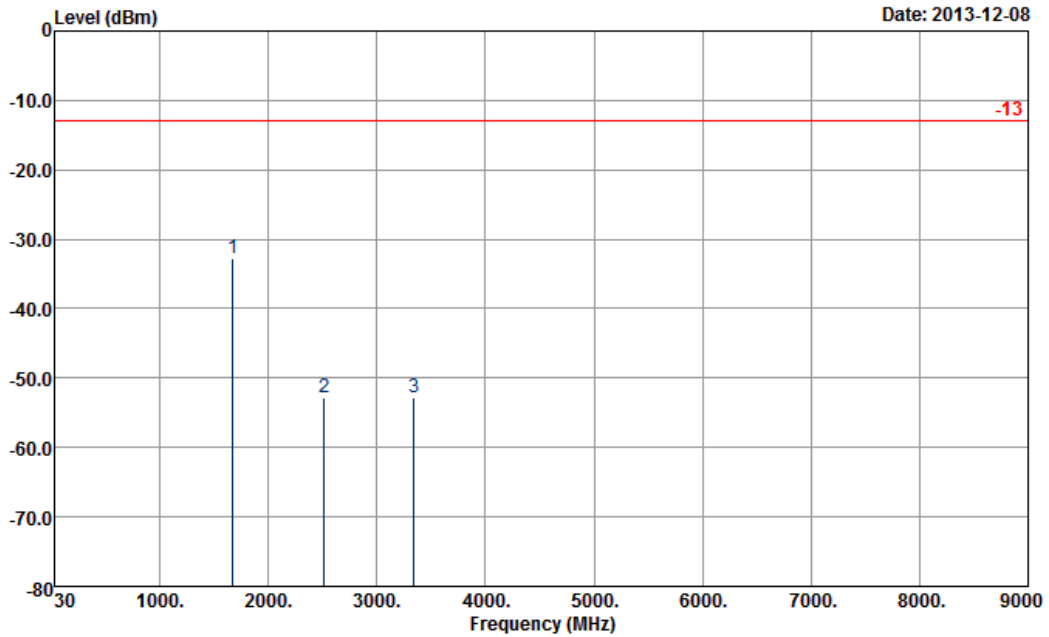

Site : 03CH07-HY  
 Condition : -13 HF-EIRP(080306) VERTICAL

Frequency ( MHz )	ERP ( dBm )	Limit ( dBm )	Over Limit ( dB )	SPA Reading ( dBm )	S.G. Power ( dBm )	TX Cable loss ( dB )	TX Antenna Gain ( dBi )	Polarization ( H/V )	Result
1672	-32.76	-13	-19.76	-43.88	-36.63	1.62	5.49	V	Pass
2512	-52.89	-13	-39.89	-66.72	-57.01	2.1	6.22	V	Pass
3344	-52.85	-13	-39.85	-68.42	-57.89	3.03	8.07	V	Pass



<b>Band :</b>	CDMA2000 BC1	<b>Temperature :</b>	21~23°C
<b>Test Mode :</b>	1xEV-DO Rev. 0_RTAP 153.6kbps Link (QPSK)	<b>Relative Humidity :</b>	53~56%
<b>Test Engineer :</b>	Stan Hsieh	<b>Polarization :</b>	Horizontal
<b>Remark :</b>	Spurious emissions within 30-1000MHz were found more than 20dB below limit line.		

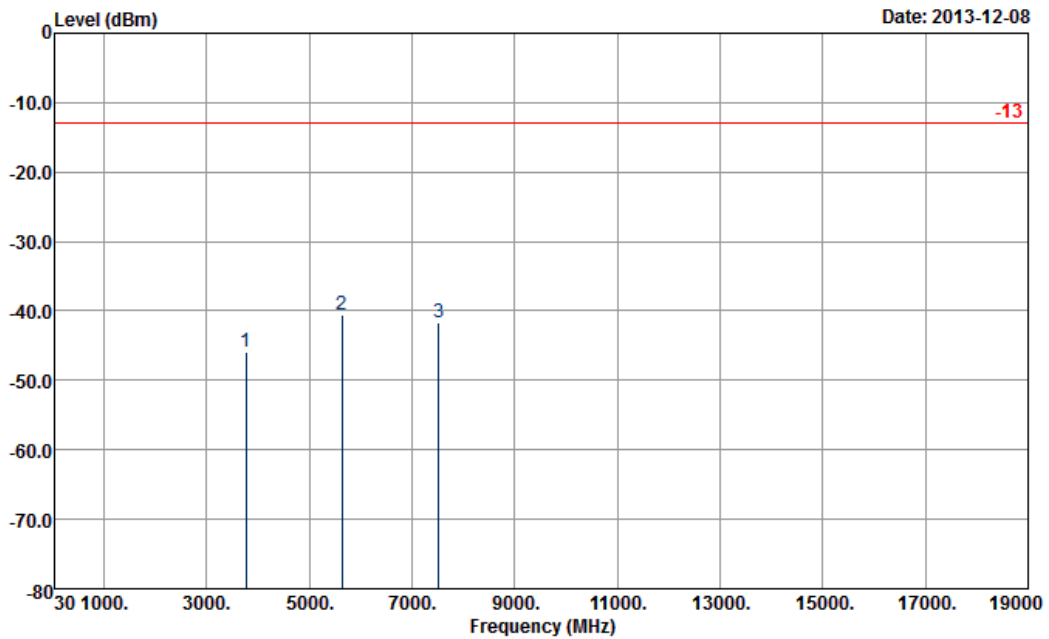

Site : 03CH07-HY  
 Condition : -13 HF-EIRP(080306) HORIZONTAL

Frequency ( MHz )	EIRP ( dBm )	Limit ( dBm )	Over Limit ( dB )	SPA Reading ( dBm )	S.G. Power ( dBm )	TX Cable loss ( dB )	TX Antenna Gain ( dBi )	Polarization ( H/V )	Result
3756	-45.91	-13	-32.91	-61.3	-52.21	2.51	8.81	H	Pass
5639	-40.54	-13	-27.54	-61.3	-48.25	2.99	10.70	H	Pass
7515	-41.61	-13	-28.61	-69	-50.14	3.59	12.12	H	Pass



<b>Band :</b>	CDMA2000 BC1	<b>Temperature :</b>	21~23°C
<b>Test Mode :</b>	1xEV-DO Rev. 0_RTAP 153.6kbps Link (QPSK)	<b>Relative Humidity :</b>	53~56%
<b>Test Engineer :</b>	Stan Hsieh	<b>Polarization :</b>	Vertical
<b>Remark :</b>	Spurious emissions within 30-1000MHz were found more than 20dB below limit line.		

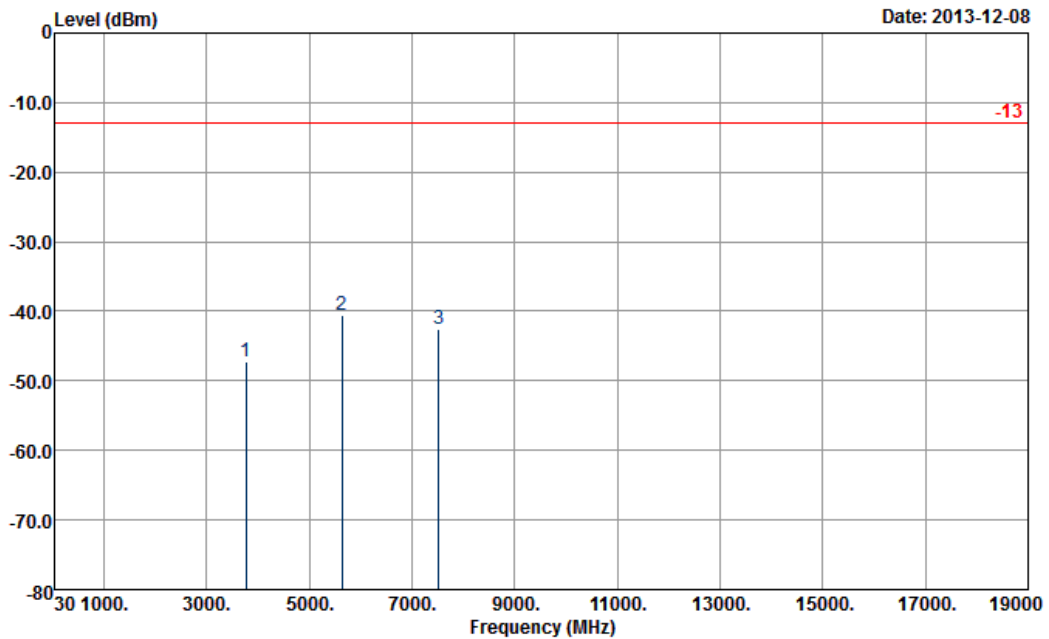

Site : 03CH07-HY  
 Condition : -13 HF-EIRP(080306) VERTICAL

Frequency ( MHz )	EIRP ( dBm )	Limit ( dBm )	Over Limit ( dB )	SPA Reading ( dBm )	S.G. Power ( dBm )	TX Cable loss ( dB )	TX Antenna Gain ( dBi )	Polarization ( H/V )	Result
3763	-47.15	-13	-34.15	-63.74	-53.45	2.51	8.81	V	Pass
5639	-40.61	-13	-27.61	-61.17	-48.32	2.99	10.70	V	Pass
7515	-42.47	-13	-29.47	-69.53	-51	3.59	12.12	V	Pass



<High Channel>

<b>Band :</b>	CDMA2000 BC0	<b>Temperature :</b>	21~23°C
<b>Test Mode :</b>	1xEV-DO Rev. 0_RTAP 153.6kbps Link (QPSK)	<b>Relative Humidity :</b>	53~56%
<b>Test Engineer :</b>	Stan Hsieh	<b>Polarization :</b>	Horizontal
<b>Remark :</b>	Spurious emissions within 30-1000MHz were found more than 20dB below limit line.		

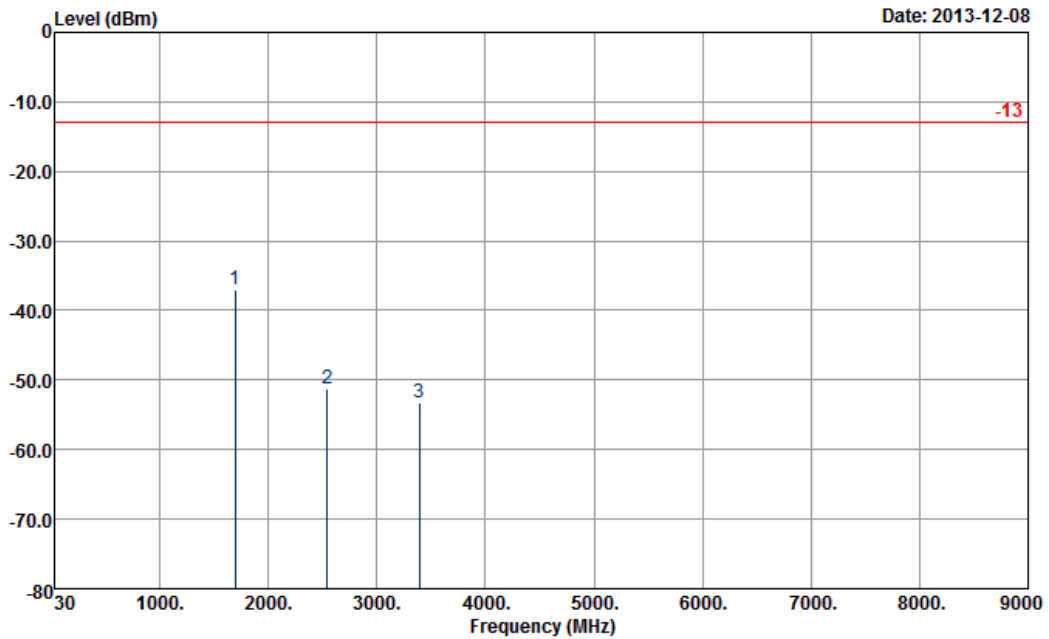

Site : 03CH07-HY  
 Condition : -13 HF-EIRP(080306) HORIZONTAL

Frequency ( MHz )	ERP ( dBm )	Limit ( dBm )	Over Limit ( dB )	SPA Reading ( dBm )	S.G. Power ( dBm )	TX Cable loss ( dB )	TX Antenna Gain ( dBi )	Polarization ( H/V )	Result
1696	-36.98	-13	-23.98	-46.01	-40.86	1.57	5.45	H	Pass
2544	-51.19	-13	-38.19	-64.51	-55.45	2.02	6.28	H	Pass
3392	-53.21	-13	-40.21	-67.43	-59.11	2.3	8.20	H	Pass



<b>Band :</b>	CDMA2000 BC0	<b>Temperature :</b>	21~23°C
<b>Test Mode :</b>	1xEV-DO Rev. 0_RTAP 153.6kbps Link (QPSK)	<b>Relative Humidity :</b>	53~56%
<b>Test Engineer :</b>	Stan Hsieh	<b>Polarization :</b>	Vertical
<b>Remark :</b>	Spurious emissions within 30-1000MHz were found more than 20dB below limit line.		

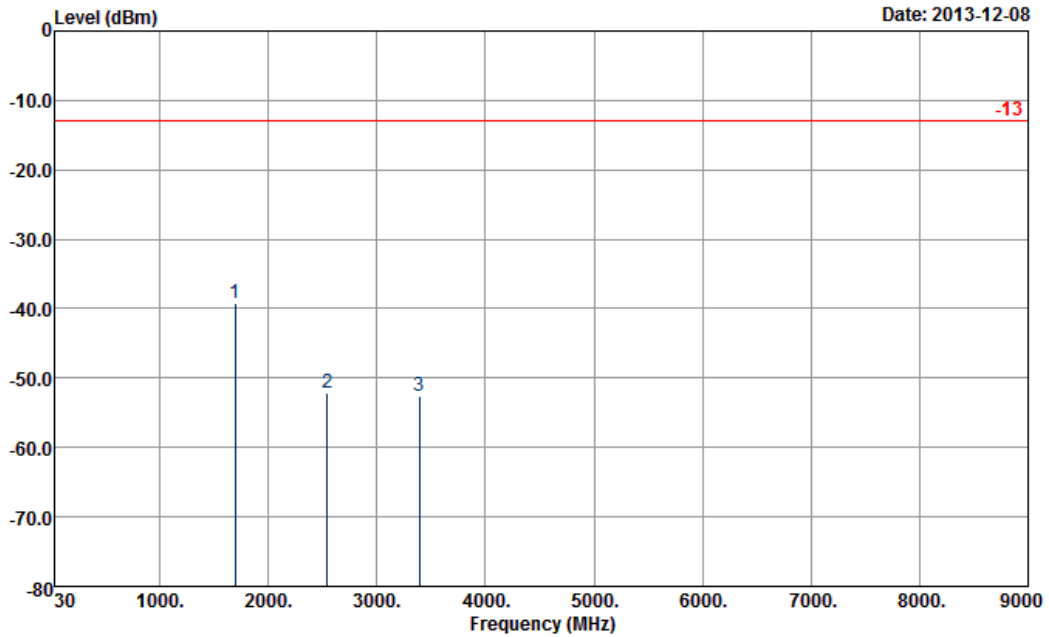

Site : 03CH07-HY  
 Condition : -13 HF-EIRP(080306) VERTICAL

Frequency ( MHz )	ERP ( dBm )	Limit ( dBm )	Over Limit ( dB )	SPA Reading ( dBm )	S.G. Power ( dBm )	TX Cable loss ( dB )	TX Antenna Gain ( dBi )	Polarization ( H/V )	Result
1696	-39.24	-13	-26.24	-50.51	-43.12	1.57	5.45	V	Pass
2544	-52.12	-13	-39.12	-66.06	-56.38	2.02	6.28	V	Pass
3392	-52.55	-13	-39.55	-68.26	-58.45	2.3	8.20	V	Pass



<b>Band :</b>	CDMA2000 BC1	<b>Temperature :</b>	21~23°C
<b>Test Mode :</b>	1xEV-DO Rev. 0_RTAP 153.6kbps Link (QPSK)	<b>Relative Humidity :</b>	53~56%
<b>Test Engineer :</b>	Stan Hsieh	<b>Polarization :</b>	Horizontal
<b>Remark :</b>	Spurious emissions within 30-1000MHz were found more than 20dB below limit line.		

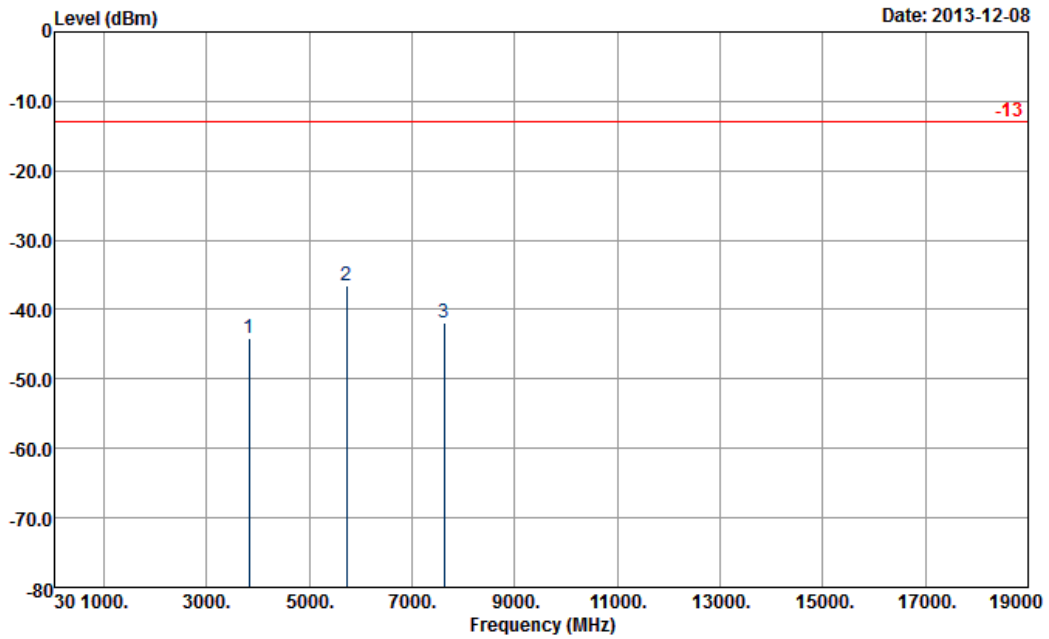

Site : 03CH07-HY  
 Condition : -13 HF-EIRP(080306) HORIZONTAL

Frequency ( MHz )	EIRP ( dBm )	Limit ( dBm )	Over Limit ( dB )	SPA Reading ( dBm )	S.G. Power ( dBm )	TX Cable loss ( dB )	TX Antenna Gain ( dBi )	Polarization ( H/V )	Result
3819	-44.05	-13	-31.05	-59.66	-50.46	2.47	8.88	H	Pass
5723	-36.45	-13	-23.45	57.57	-44.15	3	10.70	H	Pass
7627	-41.81	-13	-28.81	-68.27	-50.59	3.43	12.21	H	Pass





<b>Band :</b>	CDMA2000 BC1	<b>Temperature :</b>	21~23°C
<b>Test Mode :</b>	1xEV-DO Rev. 0_RTAP 153.6kbps Link (QPSK)	<b>Relative Humidity :</b>	53~56%
<b>Test Engineer :</b>	Stan Hsieh	<b>Polarization :</b>	Vertical
<b>Remark :</b>	Spurious emissions within 30-1000MHz were found more than 20dB below limit line.		

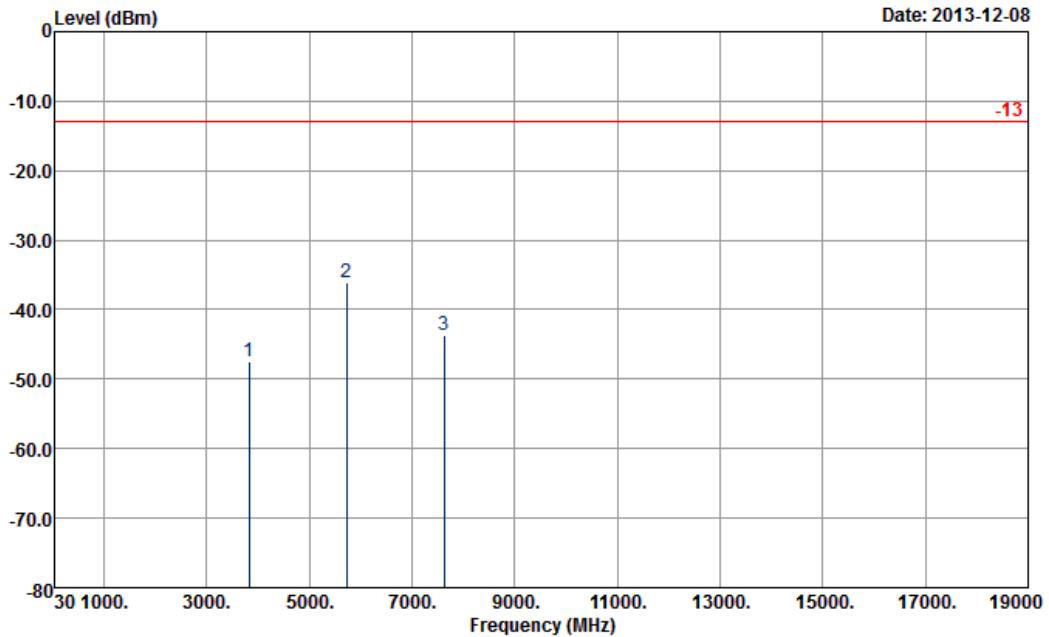

Site : 03CH07-HY  
 Condition : -13 HF-EIRP(080306) VERTICAL

Frequency ( MHz )	EIRP ( dBm )	Limit ( dBm )	Over Limit ( dB )	SPA Reading ( dBm )	S.G. Power ( dBm )	TX Cable loss ( dB )	TX Antenna Gain ( dBi )	Polarization ( H/V )	Result
3819	-47.46	-13	-34.46	-63.88	-53.87	2.47	8.88	V	Pass
5723	-36.01	-13	-23.01	-56.78	-43.71	3	10.70	V	Pass
7627	-43.58	-13	-30.58	-69.97	-52.36	3.43	12.21	V	Pass

## 3.7 Frequency Stability Measurement

### 3.7.1 Description of Frequency Stability Measurement

The frequency stability shall be measured by variation of ambient temperature and variation of primary supply voltage to ensure that the fundamental emission stays within the authorized frequency block. The frequency stability of the transmitter shall be maintained within  $\pm 0.00025\%$  ( $\pm 2.5\text{ppm}$ ) of the center frequency.

### 3.7.2 Measuring Instruments

The measuring equipment is listed in the section 4 of this test report.

### 3.7.3 Test Procedures for Temperature Variation

1. The EUT was set up in the thermal chamber and connected with the base station.
2. With power OFF, the temperature was decreased to  $-30^{\circ}\text{C}$  and the EUT was stabilized before testing. Power was applied and the maximum change in frequency was recorded within one minute.
3. With power OFF, the temperature was raised in  $10^{\circ}\text{C}$  step up to  $50^{\circ}\text{C}$ . The EUT was stabilized at each step for at least half an hour. Power was applied and the maximum frequency change was recorded within one minute.

### 3.7.4 Test Procedures for Voltage Variation

1. The EUT was placed in a temperature chamber at  $25\pm 5^{\circ}\text{C}$  and connected with the base station.
2. The power supply voltage to the EUT was varied from BEP to 115% of the nominal value measured at the input to the EUT.
3. The variation in frequency was measured for the worst case.

### 3.7.5 Test Setup

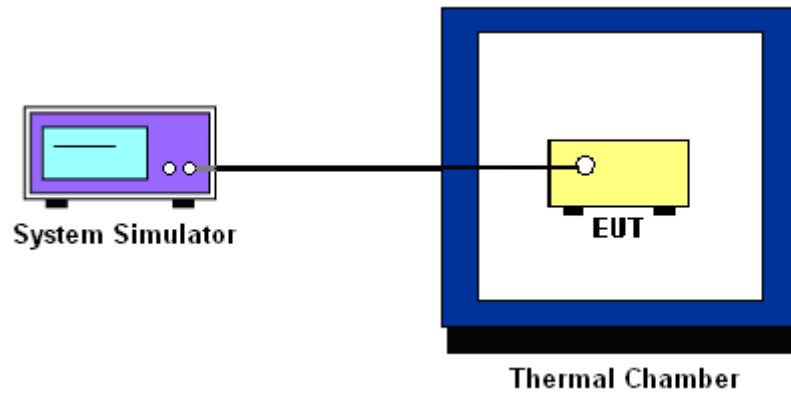



3.7.6 Test Result of Temperature Variation

<b>Band :</b>	CDMA2000 BC0 1xEV-DO Rev. 0_RTAP 153.6kbps	<b>Channel :</b>	384
<b>Limit (ppm) :</b>	2.5	<b>Frequency :</b>	836.52 MHz

Temperature (°C)	Deviation (ppm)	Result
50	0.0179	PASS
40	0.0155	
30	0.0191	
20	0.0215	
10	0.0251	
0	0.0239	
-10	0.0227	
-20	0.0263	
-30	0.0287	

<b>Band :</b>	CDMA2000 BC1 1xEV-DO Rev. 0_RTAP 153.6kbps	<b>Channel :</b>	600
<b>Limit (ppm) :</b>	2.5	<b>Frequency :</b>	1880.0 MHz

Temperature (°C)	Deviation (ppm)	Result
50	0.0096	PASS
40	0.0080	
30	0.0069	
20	0.0059	
10	0.0064	
0	0.0080	
-10	0.0080	
-20	0.0090	
-30	0.0112	



3.7.7 Test Result of Voltage Variation

Band & Channel	Mode	Voltage (Volt)	Deviation (ppm)	Limit (ppm)	Result
CDMA2000 BC0 CH384	1xEV-DO Rev. 0 RTAP 153.6kbps	8.74	0.0263	2.5	PASS
		7.60	0.0227		
		BEP	0.0251		
CDMA2000 BC1 CH600	1xEV-DO Rev. 0 RTAP 153.6kbps	8.74	0.0080	2.5	PASS
		7.60	0.0069		
		BEP	0.0074		

Note:

- 1. Normal Voltage = 7.60V.
- 2. Battery End Point (BEP) = 6.46 V.



## 4 List of Measuring Equipment

Instrument	Manufacturer	Model No.	Serial No.	Characteristics	Calibration Date	Test Date	Due Date	Remark
System Simulator	Rohde & Schwarz	CMU200	117995	N/A	Aug. 01, 2013	Dec. 12, 2013 ~ Dec. 13, 2013	Jul. 31, 2014	Conducted (TH02-HY)
Spectrum Analyzer	Rohde & Schwarz	FSP40	100055	9kHz~40GHz	Jun. 07, 2013	Dec. 12, 2013 ~ Dec. 13, 2013	Jun. 06, 2014	Conducted (TH02-HY)
Thermal Chamber	Ten Billion	TTH-D3SP	TBN-930701	N/A	Jul. 19, 2013	Dec. 12, 2013 ~ Dec. 13, 2013	Jul. 18, 2014	Conducted (TH02-HY)
Spectrum Analyzer	Rohde & Schwarz	FSP30	101067	9KHz ~ 30GHz	Nov. 20, 2013	Dec. 08, 2013	Nov. 19, 2014	Radiation (03CH07-HY)
Bilog Antenna	Schaffner	CBL6111C	2726	30MHz ~ 1GHz	Oct. 10, 2013	Dec. 08, 2013	Oct. 09, 2014	Radiation (03CH07-HY)
Double Ridge Horn Antenna	ESCO	3117	75962	1GHz~18GHz	Aug. 22, 2013	Dec. 08, 2013	Aug. 21, 2014	Radiation (03CH07-HY)
Preamplifier	COM-POWER	PA-103A	161241	30MHz~1GHz	Feb. 26, 2013	Dec. 08, 2013	Feb. 25, 2014	Radiation (03CH07-HY)
Preamplifier	Agilent	8449B	3008A01917	1GHz~26.5GHz	Aug. 12, 2013	Dec. 08, 2013	Aug. 11, 2014	Radiation (03CH07-HY)
Turn Table	ChainTek	ChainTek 3000	N/A	0 ~ 360 degree	N/A	Dec. 08, 2013	N/A	Radiation (03CH07-HY)
Antenna Mast	ChainTek	ChainTek 3000	N/A	N/A	N/A	Dec. 08, 2013	N/A	Radiation (03CH07-HY)
SHF-EHF Horn Antenna	SCHWARZBECK	BBHA 9170	BBHA9170251	15GHz- 40GHz	Oct. 03, 2013	Dec. 08, 2013	Oct. 02, 2014	Radiation (03CH07-HY)



## 5 Uncertainty of Evaluation

### Uncertainty of Radiated Emission Measurement (30 MHz ~ 1000 MHz)

Measuring Uncertainty for a Level of Confidence of 95% ( $U = 2Uc(y)$ )	4.50
---	------