

FCC Test Report

EQUIPMENT : Bar Code Handy Terminal
BRAND NAME : DENSO
MODEL NAME : BHT-710BWB-CE
FCC ID : PZWBHT710BWB
STANDARD : FCC Part 15 Subpart C §15.247
CLASSIFICATION : Digital Spread Spectrum (DSS)
APPLICANT : DENSO WAVE INCORPORATED

1-1 Showa-cho, Kariya-shi, Aichi, Japan 448-8661

The product sample received on Jan. 21, 2009 and completely tested on Feb. 13, 2009. We, SPORTON INTERNATIONAL INC., would like to declare that the tested sample has been evaluated in accordance with the procedures given in ANSI C63.4-2003 and shown compliance with the applicable technical standards.

The test results in this report apply exclusively to the tested model / sample. Without written approval of SPORTON INTERNATIONAL INC., the test report shall not be reproduced except in full.

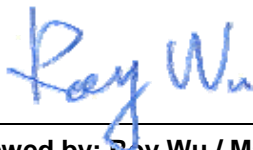

Reviewed by: Roy Wu / Manager



SPORTON INTERNATIONAL INC.

No. 52, Hwa Ya 1st Rd., Hwa Ya Technology Park, Kwei-Shan Hsiang, Tao Yuan Hsien, Taiwan, R.O.C.



TABLE OF CONTENTS

REVISION HISTORY..... 3

SUMMARY OF TEST RESULT 4

1 GENERAL DESCRIPTION..... 5

 1.1 Applicant 5

 1.2 Manufacturer..... 5

 1.3 Feature of Equipment Under Test 5

 1.4 Testing Site..... 7

 1.5 Applied Standards 7

 1.6 Ancillary Equipment List 7

2 TEST CONFIGURATION OF EQUIPMENT UNDER TEST..... 8

 2.1 Pre-Scanned RF Power..... 8

 2.2 Test Mode..... 9

 2.3 Connection Diagram of Test System..... 10

 2.4 RF Utility 10

3 TEST RESULT 11

 3.1 Number of Channel Measurement 11

 3.2 20dB Bandwidth Measurement 13

 3.3 Hopping Channel Separation Measurement 20

 3.4 Dwell Time Measurement..... 23

 3.5 Peak Output Power Measurement 25

 3.6 Band Edges Measurement..... 28

 3.7 AC Conducted Emission Measurement..... 31

 3.8 Radiated Emission Measurement..... 35

 3.9 Antenna Requirements..... 50

4 LIST OF MEASURING EQUIPMENTS 51

5 UNCERTAINTY OF EVALUATION..... 52

6 CERTIFICATION OF TAF ACCREDITATION 54

APPENDIX A. PHOTOGRAPHS OF EUT

APPENDIX B. SETUP PHOTOGRAPHS



REVISION HISTORY

REPORT NO.	VERSION	DESCRIPTION	ISSUED DATE
FR912101B	Rev. 01	Initial issue of report	Feb. 20, 2009
FR912101B	Rev. 02	Update applicant address	Feb. 23, 2009
FR912101B	Rev. 03	Update test mode of conducted emission	Mar. 27, 2009



SUMMARY OF TEST RESULT

Report Section	FCC Rule	IC Rule	Description	Limit	Result	Remark
3.1	15.247(b)(1)	A8.4(2)	Number of Channels	≥ 15Chs	Pass	
3.2	15.247(a)(1)	A8.1(a)	20dB Bandwidth	NA	Pass	-
3.3	15.247(a)(1)	A8.1(b)	Channel Separation	≥ 2/3 of 20dB BW	Pass	-
3.4	15.247(a)(1)	A8.1(d)	Dwell Time of Each Channel	≤ 0.4sec in 31.6sec period	Pass	-
3.5	15.247(a)(1)	A8.1(b)	Peak Output Power	≤ 1W	Pass	-
3.6	15.247(d)	A8.5	Frequency Band Edges	≤ 20dBc	Pass	-
3.7	15.207	Gen 7.2.2	AC Conducted Emission	15.207(a)	Pass	Under limit 13.9 dB at 0.534 MHz
3.8	15.247(d)	A8.5	Transmitter Radiated Emission	15.209(a) & 15.247(d)	Pass	Under limit 4.02 dB at 30.00 MHz
3.9	15.203 & 15.247(b)	A8.4	Antenna Requirement	N/A	Pass	-



1 General Description

1.1 Applicant

DENSO WAVE INCORPORATED

1-1 Showa-cho, Kariya-shi, Aichi, Japan 448-8661

1.2 Manufacturer

Universal Scientific Industrial CO., LTD.

No. 141, Lane 351, Taiping Road, Sec. 1, Tsao Tuen, Nan-Tou, Taiwan

1.3 Feature of Equipment Under Test

Product Feature & Specification	
Equipment	Bar Code Handy Terminal
Brand Name	DENSO
Model Name	BHT-710BWB-CE
Tx/Rx Frequency Range	2400 MHz ~ 2483.5 MHz
Number of Channels	79
Carrier Frequency of Each Channel	2402+n*1 MHz; n=0~78
Channel Spacing	1 MHz
Maximum Output Power to Antenna	Bluetooth (1Mbps) : 2.14 dBm Bluetooth EDR (2Mbps) : 3.27 dBm Bluetooth EDR (3Mbps) : 3.58 dBm
Antenna Type	Chip Antenna with gain -0.03 dBi
Antenna Connector Type	Fixed On Board
HW Version	V3.4
SW Version	1.16a
Type of Modulation	Bluetooth (1Mbps) : GFSK Bluetooth EDR (2Mbps) : /4-DQPSK Bluetooth EDR (3Mbps) : 8-DPSK
EUT Stage	Production Unit



Accessories List:

Accessories Specification		
Battery 1	Brand Name	DENSO
	Model Name	BT-700LL
	Power Rating	3.6Vdc, 3800mAh
	Type	Li-ion
Battery 2	Brand Name	DENSO
	Model Name	BT-700L
	Power Rating	3.7Vdc, 2200mAh
	Type	Li-ion

Remark:

1. The above EUT's information was declared by manufacturer. Please refer to the specifications or user's manual for more detailed description.
2. This test report recorded only product characteristics and test results of Digital Spread Spectrum (DSS).
3. For accessories equipped with this EUT, please refer to the appendix of the external photo.
4. For other wireless features of this EUT, test report will be issued separately.

1.4 Testing Site

Test Site	SPORTON INTERNATIONAL INC.		
Test Site Location	No. 52, Hwa Ya 1 st Rd., Hwa Ya Technology Park, Kwei-Shan Hsiang, Tao Yuan Hsien, Taiwan, R.O.C TEL: +886-3-3273456 / FAX: +886-3-3284978		
Test Site No.	Sporton Site No.		FCC/IC Registration No.
	CO05-HY	03CH07-HY	TW1022/4086B-1

1.5 Applied Standards

According to the specifications of the manufacturer, the EUT must comply with the requirements of the following standards:

- ♦ FCC Part 15 Subpart C §15.247
- ♦ FCC Public Notice DA 00-705
- ♦ ANSI C63.4-2003
- ♦ IC RSS-210 Issue 7

Remark:

1. All test items were verified and recorded according to the standards and without any deviation during the test.
2. This EUT has also been tested and complied with the requirements of FCC Part 15, Subpart B (DoC), recorded in a separate test report.

1.6 Ancillary Equipment List

Item	Equipment	Trade Name	Model Name	FCC ID	Data Cable	Power Cord
1.	BT Base Station	Anritsu	8852B	N/A	N/A	Unshielded, 1.8 m
2.	WLAN AP	D-Link	DWL-7100AP	KA22003040018-1	N/A	Unshielded, 1.8 m
3.	Bluetooth Earphone	Cellink	BTHS-6025-F	PQY-4710874200357	N/A	N/A

2 Test Configuration of Equipment Under Test

2.1 Pre-Scanned RF Power

Preliminary tests were performed in different data rate and recorded the RF output power in the following table:

Channel	Frequency	Bluetooth RF Output Power		
		Data Rate / Modulation		
		GFSK	/4-DQPSK	8-DPSK
		1Mbps	2Mbps	3Mbps
Ch00	2402MHz	0.65 dBm	2.38 dBm	2.69 dBm
Ch39	2441MHz	1.70 dBm	2.93 dBm	3.26 dBm
Ch78	2480MHz	2.14 dBm	3.27 dBm	3.58 dBm

Remark:

1. The data rate 3Mbps was set for all the test cases, due to the highest RF output power.
2. The data rate 3Mbps was set for dwell time test case.
3. The EUT is programmed to transmit signal continuously for all testing.

2.2 Test Mode

The EUT has been associated with peripherals pursuant to ANSI C63.4-2003 and configuration operated in a manner tended to maximize its emission characteristics in a typical application. Frequency range investigated: conduction (150 kHz to 30 MHz), radiation (9 kHz to the 10th harmonic of the highest fundamental frequency or to 40 GHz, whichever is lower). Pre-scanned tests were conducted to determine the final configuration from all possible combinations. The following tables are showing the test modes as the worst cases and recorded in this report.

Test Cases			
Test Item	Data Rate / Modulation		
	Bluetooth 1Mbps GFSK	Bluetooth EDR 2Mbps /4-DQPSK	Bluetooth EDR 3Mbps 8-DPSK
Conducted TCs	<ul style="list-style-type: none"> ■ Mode 1: CH00_2402 MHz ■ Mode 2: CH39_2441 MHz ■ Mode 3: CH78_2480 MHz 	<ul style="list-style-type: none"> ■ Mode 4: CH00_2402 MHz ■ Mode 5: CH39_2441 MHz ■ Mode 6: CH78_2480 MHz 	<ul style="list-style-type: none"> ■ Mode 7: CH00_2402 MHz ■ Mode 8: CH39_2441 MHz ■ Mode 9: CH78_2480 MHz
Radiated TCs	N/A	N/A	<ul style="list-style-type: none"> ■ Mode 1: CH00_2402 MHz ■ Mode 2: CH39_2441 MHz ■ Mode 3: CH78_2480 MHz
AC Conducted Emission	<ul style="list-style-type: none"> ■ Mode 1 : BT Link + Cradle + Adapter 		
<p>Remark:</p> <ol style="list-style-type: none"> 1. The worst case of conducted TCs is Bluetooth 3Mbps, only the test data of these modes was reported. 2. The worst cases of radiated emission were Bluetooth 3Mbps Tx modes; only the test data of these modes were reported. 			

2.3 Connection Diagram of Test System

<Conducted Emission>

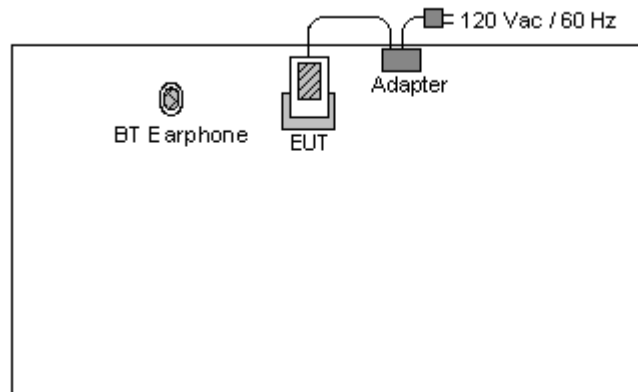

<Radiated Emission>

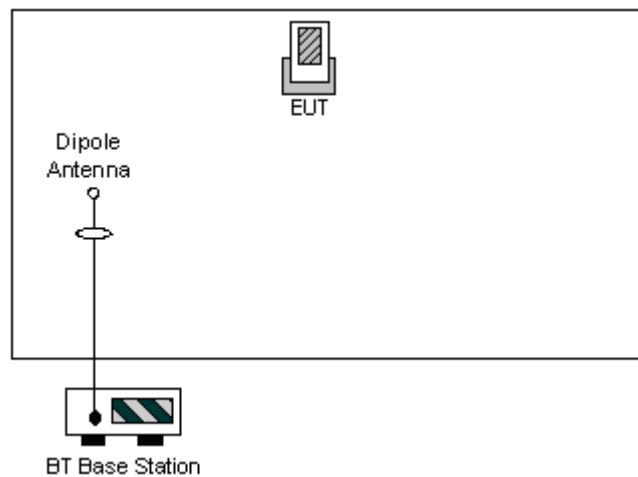

2.4 RF Utility

For Bluetooth function, the RF Utility, "BluetoothtestMode" was installed in EUT which was programmed in order to make the EUT into the engineering modes to contact with BT base station for transmitting and receiving signals continuously.

3 Test Result

3.1 Number of Channel Measurement

3.1.1 Limits of Number of Hopping Frequency

Frequency hopping systems in the 2400-2483.5 MHz band shall use at least 15 channels.

3.1.2 Measuring Instruments

See list of measuring instruments of this test report.

3.1.3 Test Procedure

1. The testing follows FCC Public Notice DA 00-705 Measurement Guidelines.
2. The RF output of EUT was connected to the spectrum analyzer by a low loss cable.
3. The modulation types of EUT are irrelevant to number of hopping channels deviation.
4. The EUT must have its hopping function enabled. Use the following spectrum analyzer settings:
Span = the frequency band of operation; RBW \geq 1% of the span; VBW \geq RBW; Sweep = auto;
Detector function = peak; Trace = max hold.
5. The number of hopping frequency used is defined as the device has the numbers of total channel.

3.1.4 Test Setup

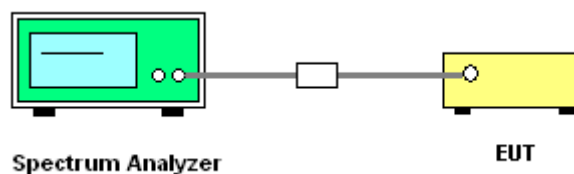



3.1.5 Test Result of Number of Hopping Frequency

Test Mode :	Mode 7~9	Temperature :	24~26
Test Engineer :	Eric Hum	Relative Humidity :	47~49%
Number of Hopping Channels (Channel)		Limits (Channel)	
79		> 15	
		Pass/Fail	
		Pass	

Number of Hopping Channel Plot on Channel 00 - 78

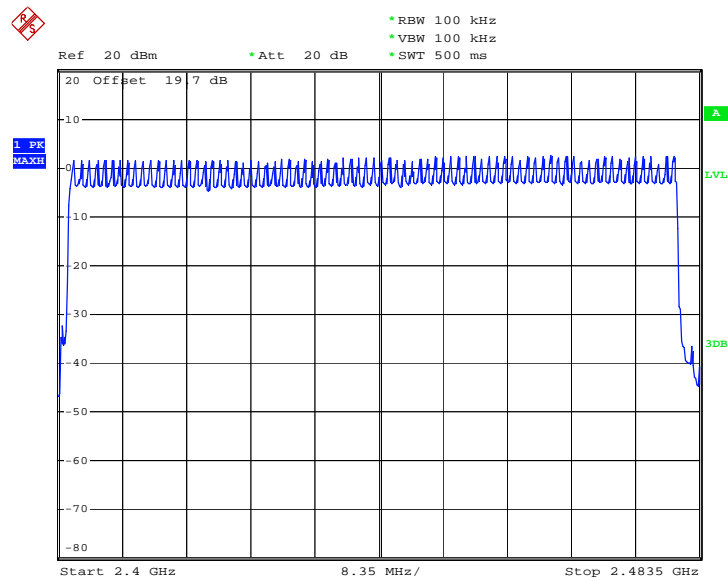

Date: 23.JAN.2009 20:04:10

3.2 20dB Bandwidth Measurement

3.2.1 Limit of 20dB Bandwidth

N/A

3.2.2 Measuring Instruments

See list of measuring instruments of this test report.

3.2.3 Test Procedures

1. The testing follows FCC Public Notice DA 00-705 Measurement Guidelines.
2. The RF output of EUT was connected to the spectrum analyzer by a low loss cable.
3. The EUT should be transmitting at its maximum data rate as the worst cases.
4. Use the following spectrum analyzer settings:
Span = approximately 2 to 3 times the 20 dB bandwidth, centered on a hopping channel;
RBW \geq 1% of the 20 dB bandwidth; VBW \geq RBW; Sweep = auto; Detector function = peak;
Trace = max hold.
5. The marker-delta reading at this point is the 20 dB bandwidth of the emission.

3.2.4 Test Setup

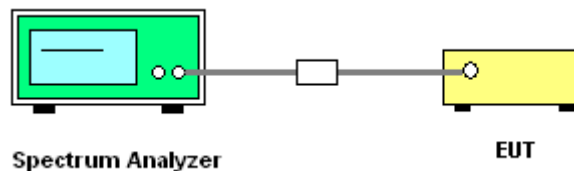



3.2.5 Test Result of 20dB Bandwidth

Test Mode :	Mode 1, 2, 3	Temperature :	24~26
Test Engineer :	Eric Hum	Relative Humidity :	47~49%

Channel	Frequency (MHz)	20dB Bandwidth (MHz)
00	2402	0.802
39	2441	0.798
78	2480	0.802

20 dB Bandwidth Plot on Channel 00

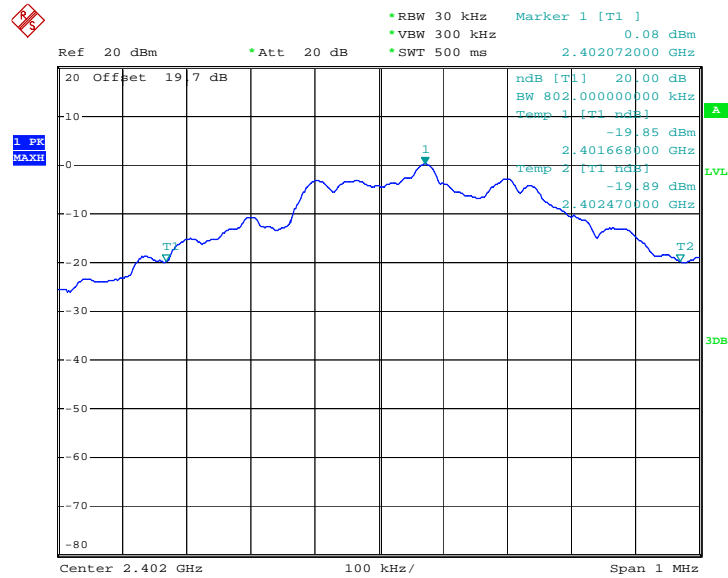

Date: 23.JAN.2009 18:31:43



20 dB Bandwidth Plot on Channel 39

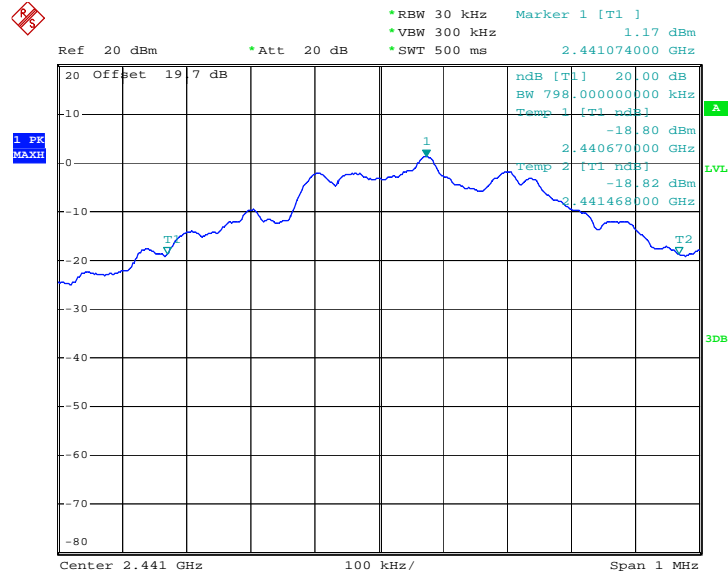

Date: 23.JAN.2009 18:32:04

20 dB Bandwidth Plot on Channel 78

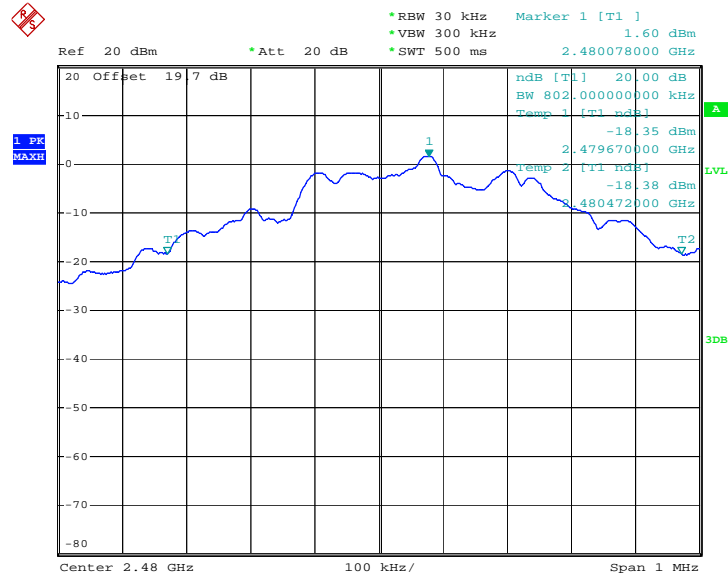

Date: 23.JAN.2009 18:32:36



Test Mode :	Mode 4, 5, 6	Temperature :	24~26
Test Engineer :	Eric Hum	Relative Humidity :	47~49%

Channel	Frequency (MHz)	20dB Bandwidth (MHz)
00	2402	1.220
39	2441	1.220
78	2480	1.220

20 dB Bandwidth Plot on Channel 00

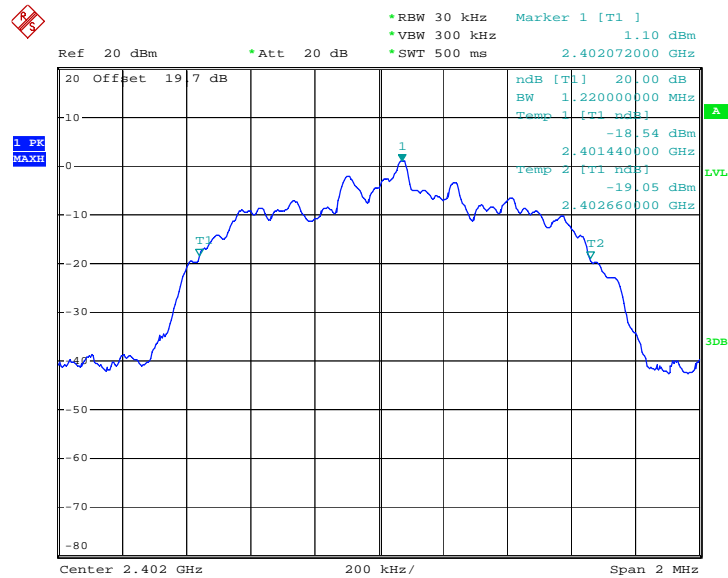

Date: 23.JAN.2009 18:33:53



20 dB Bandwidth Plot on Channel 39

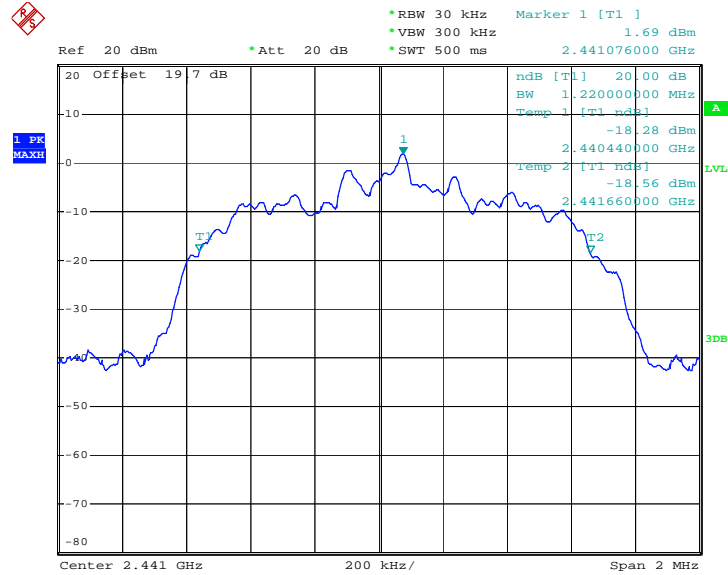

Date: 23.JAN.2009 18:34:18

20 dB Bandwidth Plot on Channel 78

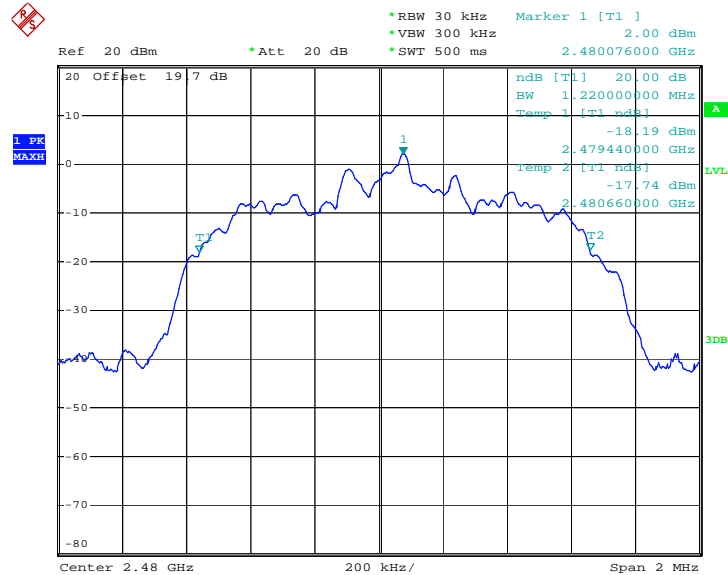

Date: 23.JAN.2009 18:34:46



Test Mode :	Mode 7, 8, 9	Temperature :	24~26
Test Engineer :	Eric Hum	Relative Humidity :	47~49%

Channel	Frequency (MHz)	20dB Bandwidth (MHz)
00	2402	1.268
39	2441	1.264
78	2480	1.268

20 dB Bandwidth Plot on Channel 00

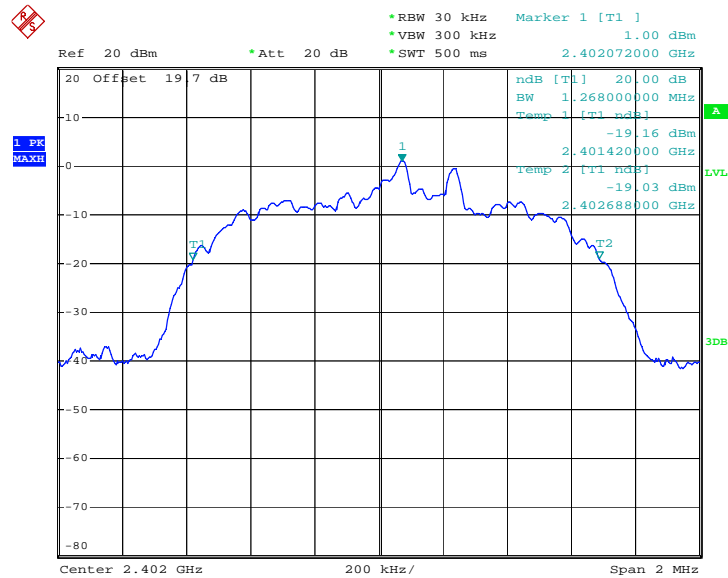

Date: 23.JAN.2009 18:35:50



20 dB Bandwidth Plot on Channel 39

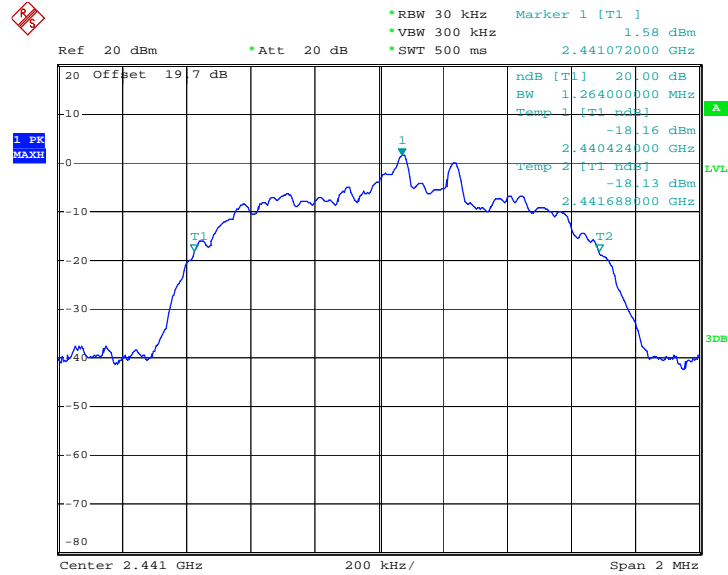

Date: 23.JAN.2009 18:36:19

20 dB Bandwidth Plot on Channel 78

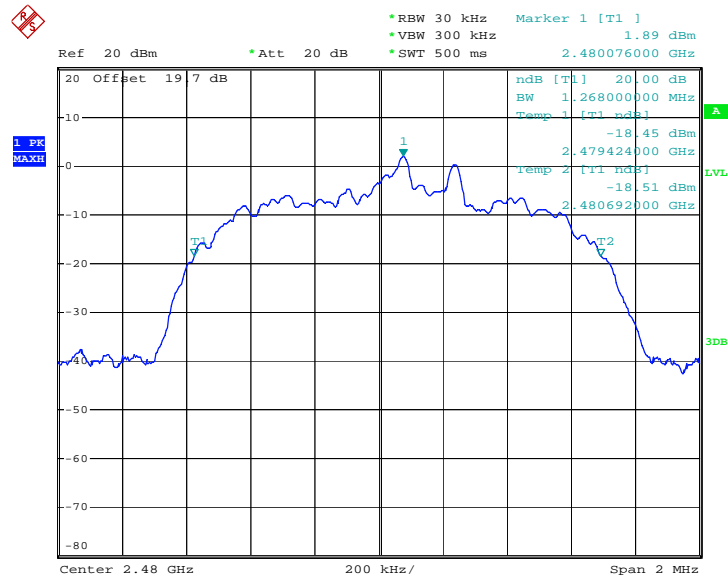

Date: 23.JAN.2009 18:36:42

3.3 Hopping Channel Separation Measurement

3.3.1 Limit of Hopping Channel Separation

Frequency hopping systems operating in the 2400-2483.5 MHz band may have hopping channel carrier frequencies that are separated by 25 kHz or two-thirds of the 20 dB bandwidth of the hopping channel, whichever is greater, provided the systems operate with an output power no greater than 1 W.

3.3.2 Measuring Instruments

See list of measuring instruments of this test report.

3.3.3 Test Procedures

1. Please refer FCC Public Notice DA 00-705 Measurement Guidelines.
2. The RF output of EUT was connected to the spectrum analyzer by a low loss cable.
3. The EUT should be transmitting at its maximum data rate as the worst cases.
4. Use the following spectrum analyzer settings:
Span = wide enough to capture the peaks of two adjacent channels; $RBW \geq 1\%$ of the span;
 $VBW \geq RBW$; Sweep = auto; Detector function = peak; Trace = max hold.
5. Use the marker-delta function to determine the separation between the peaks of the adjacent channels.

3.3.4 Test Setup

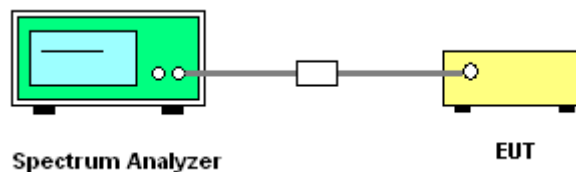



3.3.5 Test Result of Hopping Channel Separation

Test Mode :	Mode 7, 8, 9	Temperature :	24~26
Test Engineer :	Eric Hum	Relative Humidity :	47~49%

Channel	Frequency (MHz)	Frequency Separation (MHz)	(2/3 of 20dB BW) Limits (MHz)	Pass/Fail
00	2402	1.000	0.845	Pass
39	2441	1.000	0.843	Pass
78	2480	1.000	0.845	Pass

Channel Separation Plot on Channel 00 - 01

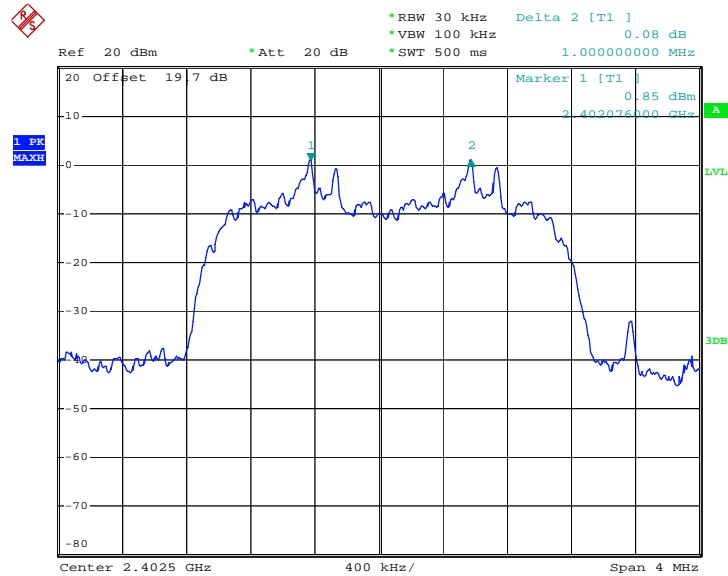

Date: 23.JAN.2009 18:52:19



Channel Separation Plot on Channel 39 - 40

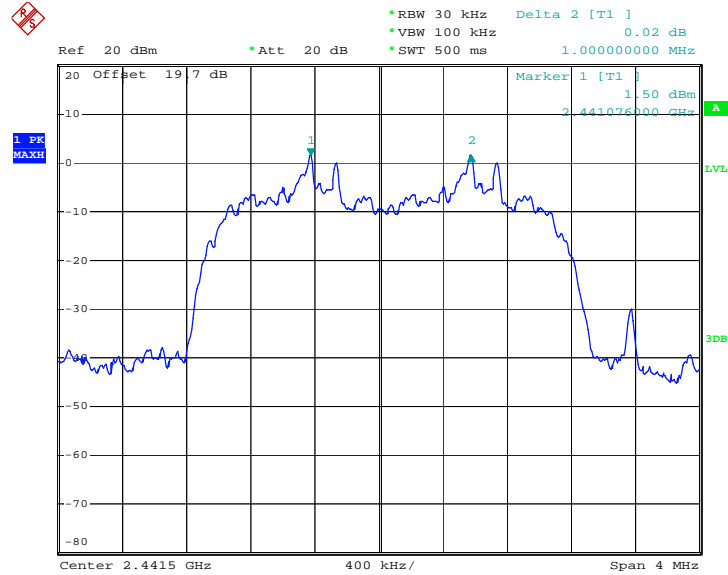

Date: 23.JAN.2009 18:52:53

Channel Separation Plot on Channel 77 - 78

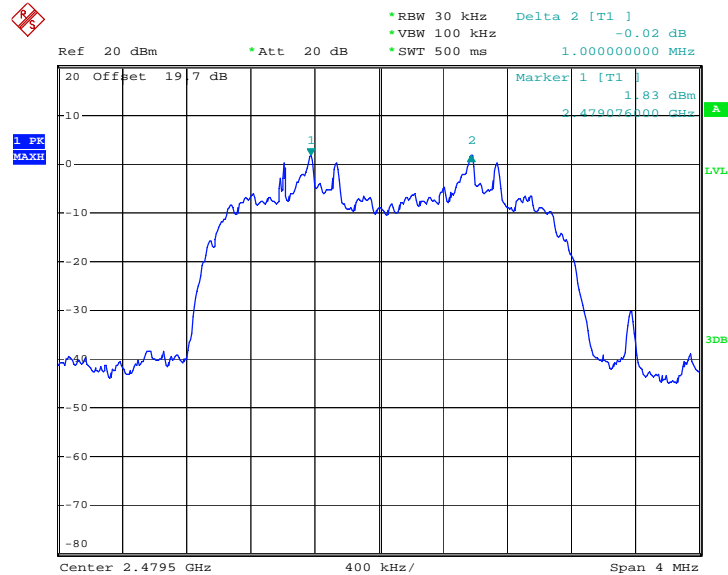

Date: 23.JAN.2009 18:53:26

3.4 Dwell Time Measurement

3.4.1 Limit of Dwell Time

The average time of occupancy on any channel shall not be greater than 0.4 seconds within a period of 0.4 seconds multiplied by the number of hopping channels employed.

3.4.2 Measuring Instruments

See list of measuring instruments of this test report.

3.4.3 Test Procedures

1. The testing follows FCC Public Notice DA 00-705 Measurement Guidelines.
2. The RF output of EUT was connected to the spectrum analyzer by a low loss cable.
3. The EUT should be transmitting at its maximum data rate as the worst cases.
4. The EUT must have its hopping function enabled. Use the following spectrum analyzer settings:
Span = zero span, centered on a hopping channel; RBW = 1 MHz; VBW ≥ RBW; Sweep = as necessary to capture the entire dwell time per hopping channel; Detector function = peak; Trace = max hold.
5. Use the marker-delta function to calculate the dwell time.

3.4.4 Test Setup

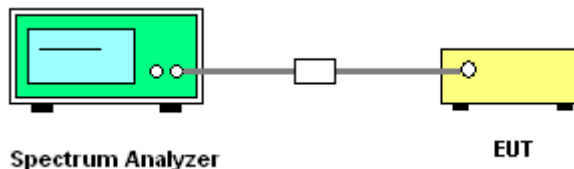

3.4.5 Test Result of Dwell Time

Test Mode :	Mode 8	Temperature :	24~26
Test Engineer :	Eric Hum	Relative Humidity :	47~49%

Package Mode	Average Hopping Channel	Package Transfer Time (usec)	Dwell Time (sec)	Limits (sec)	Pass/Fail
3DH5	2.70	3012.00	0.26	0.4	Pass

Remark:

1. Dwell Time=79(channels) x 0.4(s) x average hopping channel x package transfer time
2. 79 channels come from the Hopping Channel number.
3. Average Hopping Channel = hops/sweep time
4. t: Package Transfer Time(us)



3DH5 Dwell Time (One Pulse) Plot on Channel 39

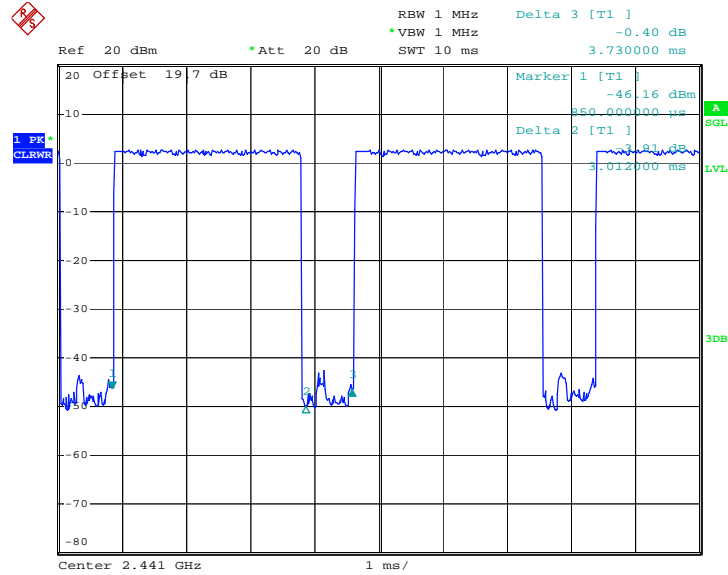

Date: 23.JAN.2009 19:11:48

3DH5 Dwell Time (Count Pulses) Plot on Channel 39

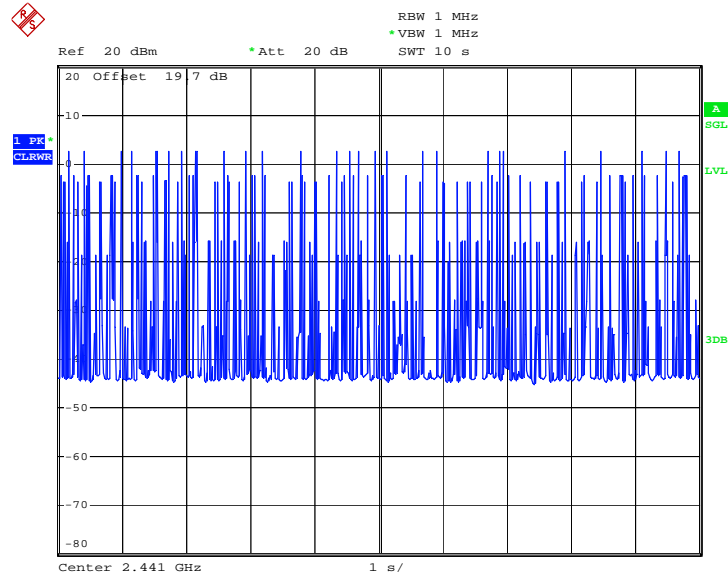

Date: 23.JAN.2009 19:46:12

3.5 Peak Output Power Measurement

3.5.1 Limit of Peak Output Power

Frequency hopping systems operating in the 2400-2483.5 MHz band may have hopping channel carrier frequencies that are separated by 25 kHz or two-thirds of the 20 dB bandwidth of the hopping channel, whichever is greater, provided the systems operate with an output power no greater than 1 W (30dBm).

3.5.2 Measuring Instruments

See list of measuring instruments of this test report.

3.5.3 Test Procedures

1. The testing follows FCC Public Notice DA 00-705 Measurement Guidelines.
2. The RF output of EUT was connected to the peak power meter by a low loss cable.

3.5.4 Test Setup

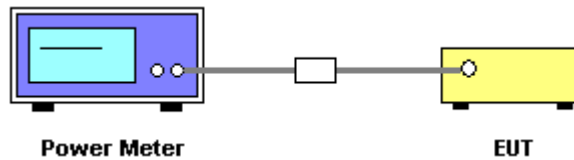

3.5.5 Test Result of Peak Output Power

Test Mode :	Mode 7, 8, 9	Temperature :	24~26
Test Engineer :	Eric Hum	Relative Humidity :	47~49%

Channel	Frequency (MHz)	RF Power (dBm)		
		8-DPSK	Max. Limits (dBm)	Pass/Fail
		3 Mbps		
00	2402	2.69	30	Pass
39	2441	3.26	30	Pass
78	2480	3.58	30	Pass



Peak Output Power Plot on Channel 00

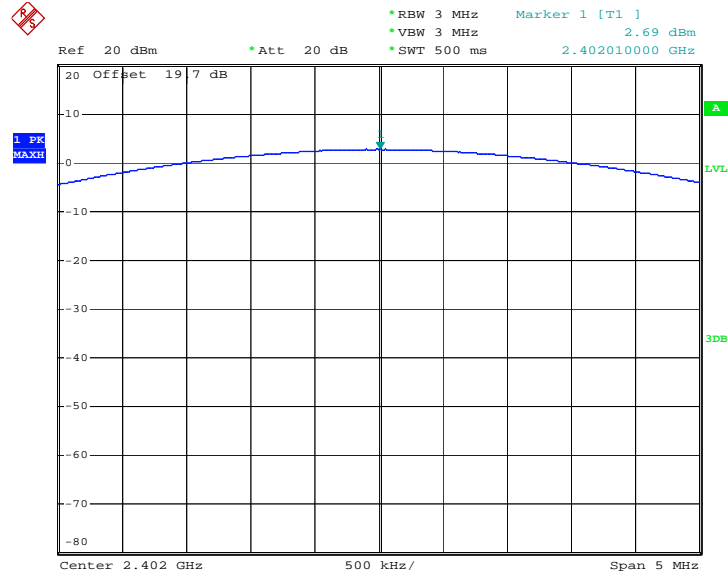

Date: 23.JAN.2009 18:11:42

Peak Output Power Plot on Channel 39

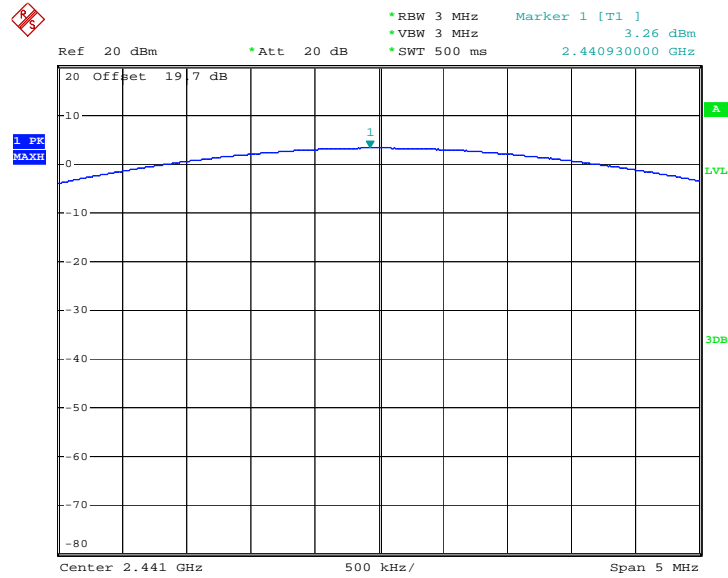

Date: 23.JAN.2009 18:12:09



Peak Output Power Plot on Channel 78

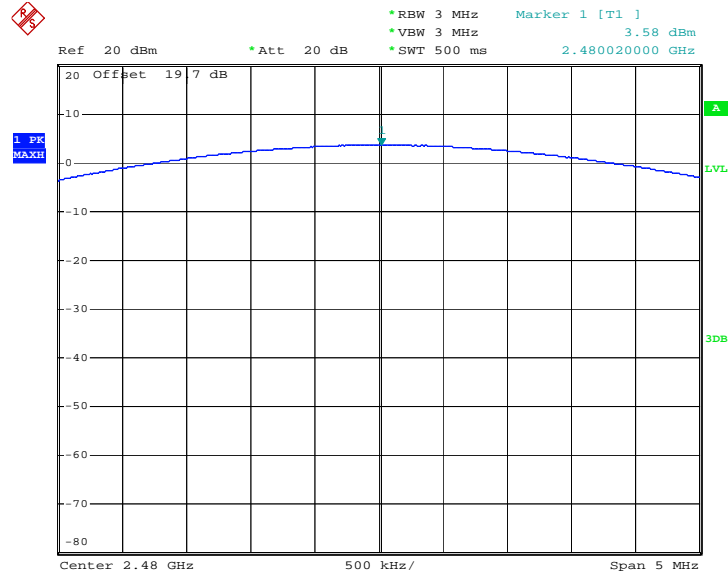

Date: 23.JAN.2009 18:12:27

3.6 Band Edges Measurement

3.6.1 Limit of Band Edges

In any 100 kHz bandwidth outside the intentional radiation frequency band, the radio frequency power shall be at least 20 dB below the highest level of the radiated power. In addition, radiated emissions which fall in the restricted bands must also comply with the radiated emission limits.

3.6.2 Measuring Instruments

See list of measuring instruments of this test report.

3.6.3 Test Procedures

1. The testing follows the guidelines in ANSI C63.4-2003 and FCC Public Notice DA 00-705 Measurement Guidelines.
2. RF antenna conducted test: Set RBW = 100 kHz, Video bandwidth (VBW) > RBW, scan up through 10th harmonic. Band edge emissions must be at least 20 dB down from the highest emission level within the authorized band as measured with a 100 kHz RBW. Note: If the device complies with the use of power option 2 the attenuation under this paragraph shall be 30 dB instead of 20 dB.
3. Radiated emission test: Applies to band edge emissions that fall in the restricted bands listed in FCC Section 15.205. The maximum permitted average field strength is listed in FCC Section 15.209. A pre-amp is necessary for this measurement. For measurements above 1 GHz, set RBW = 1MHz, VBW = 10 Hz, Sweep: Auto. If the emission is pulsed, modify the unit for continuous operation; use the settings shown above, then correct the reading by subtracting the peak-average correction factor, derived from the appropriate duty cycle calculation. See FCC Section 15.35(b) and (c).

3.6.4 Test Setup

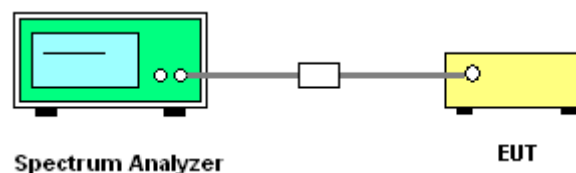



3.6.5 Test Result of Radiated Band Edges

Test Mode :	Mode 1	Temperature :	24~26°C
Test Channel :	00	Relative Humidity :	47~49%
Test Engineer :	Elvis Chen		

ANTENNA POLARITY : HORIZONTAL										
Frequency (MHz)	Level (dBuV/m)	Over Limit (dB)	Limit Line (dBuV/m)	Read Level (dBuV)	Antenna Factor (dB)	Cable Loss (dB)	Preamp Factor (dB)	Ant Pos (cm)	Table Pos (deg)	Remark
2385.81	44.71	-29.29	74	42.60	32.32	5.46	35.67	100	0	Peak
2385.81	32.21	-21.79	54	30.10	32.32	5.46	35.67	100	234	Average

ANTENNA POLARITY : VERTICAL										
Frequency (MHz)	Level (dBuV/m)	Over Limit (dB)	Limit Line (dBuV/m)	Read Level (dBuV)	Antenna Factor (dB)	Cable Loss (dB)	Preamp Factor (dB)	Ant Pos (cm)	Table Pos (deg)	Remark
2353.7	44.28	-29.72	74	42.16	32.30	5.49	35.67	100	44	Peak
2353.7	30.47	-23.53	54	28.35	32.30	5.49	35.67	100	44	Average

Test Mode :	Mode 3	Temperature :	24~26°C
Test Channel :	78	Relative Humidity :	47~49%
Test Engineer :	Elvis Chen		

ANTENNA POLARITY : HORIZONTAL										
Frequency (MHz)	Level (dBuV/m)	Over Limit (dB)	Limit Line (dBuV/m)	Read Level (dBuV)	Antenna Factor (dB)	Cable Loss (dB)	Preamp Factor (dB)	Ant Pos (cm)	Table Pos (deg)	Remark
2483.5	59.20	-14.8	74	57.21	32.30	5.38	35.69	100	229	Peak
2483.5	45.74	-8.26	54	43.75	32.30	5.38	35.69	102	229	Average

ANTENNA POLARITY : VERTICAL										
Frequency (MHz)	Level (dBuV/m)	Over Limit (dB)	Limit Line (dBuV/m)	Read Level (dBuV)	Antenna Factor (dB)	Cable Loss (dB)	Preamp Factor (dB)	Ant Pos (cm)	Table Pos (deg)	Remark
2483.5	58.51	-15.49	74	56.52	32.30	5.38	35.69	100	0	Peak
2483.5	44.30	-9.70	54	42.31	32.30	5.38	35.69	100	37	Average



3.6.6 Test Result of Conducted Band Edges

Test Mode :	Mode 7 and 9	Temperature :	24~26
Test Channel :	00 and 78	Relative Humidity :	47~49%
Test Engineer :	Eric Hum		

Low Band Edge Plot on Channel 00

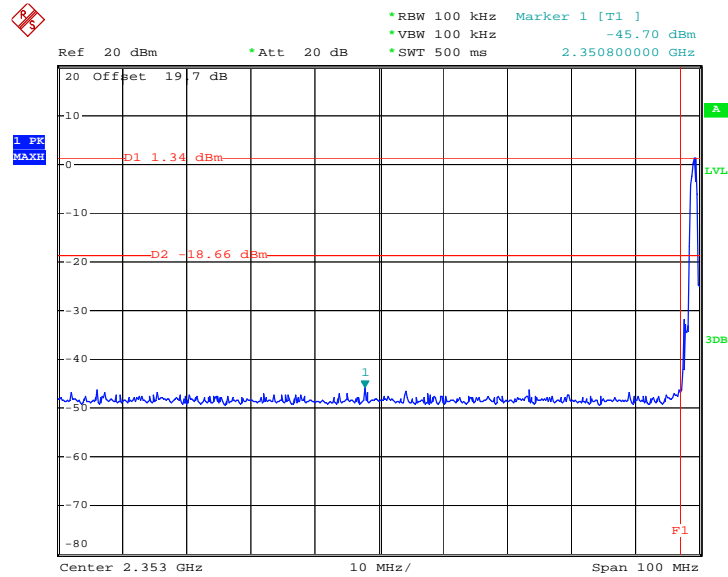

Date: 23.JAN.2009 18:51:07

High Band Edge Plot on Channel 78

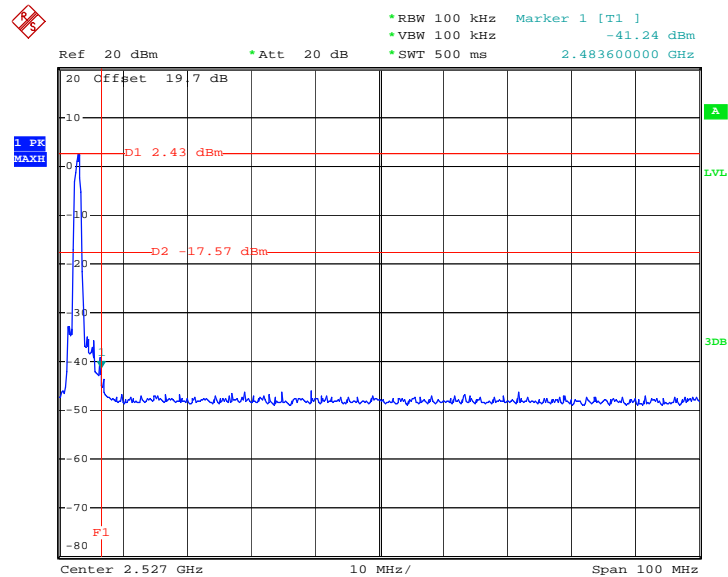

Date: 23.JAN.2009 18:39:19

3.7 AC Conducted Emission Measurement

3.7.1 Limit of AC Conducted Emission

For equipment that is designed to be connected to the public utility (AC) power line, the radio frequency voltage that is conducted back onto the AC power line on any frequency or frequencies within the band 150 kHz to 30 MHz shall not exceed the limits in the following table.

Frequency of emission (MHz)	Conducted limit (dBuV)	
	Quasi-peak	Average
0.15-0.5	66 to 56*	56 to 46*
0.5-5	56	46
5-30	60	50

*Decreases with the logarithm of the frequency.

3.7.2 Measuring Instruments

See list of measuring instruments of this test report.

3.7.3 Test Procedures

1. Please follow the guidelines in ANSI C63.4-2003.
2. The EUT was placed 0.4 meter from the conducting wall of the shielding room was kept at least 80 centimeters from any other grounded conducting surface.
3. Connect EUT to the power mains through a line impedance stabilization network (LISN).
4. All the support units are connecting to the other LISN.
5. The LISN provides 50 ohm coupling impedance for the measuring instrument.
6. The FCC states that a 50 ohm, 50 microhenry LISN should be used.
7. Both sides of AC line were checked for maximum conducted interference.
8. The frequency range from 150 kHz to 30 MHz was searched.
9. Set the test-receiver system to Peak Detect Function and specified bandwidth with Maximum Hold Mode.

3.7.4 Test Setup

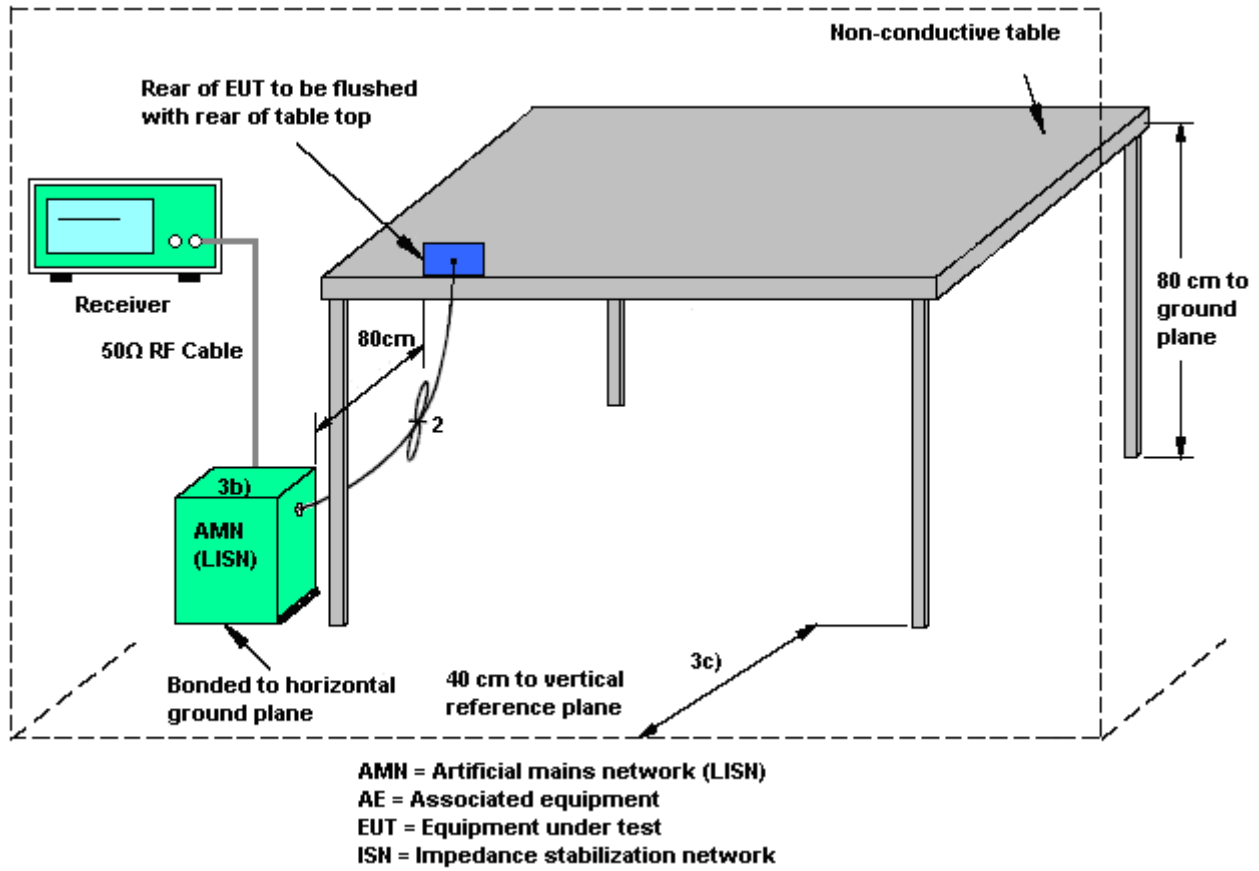

3.7.5 Test Result of AC Conducted Emission

Test Mode :	Mode 1	Temperature :	23~24
Test Engineer :	Cona Huang	Relative Humidity :	43~44%
		Phase :	Line
Function Type :	BT Link + Cradle + Adapter		
Remark :	All emissions not reported here are more than 10 dB below the prescribed limit.		

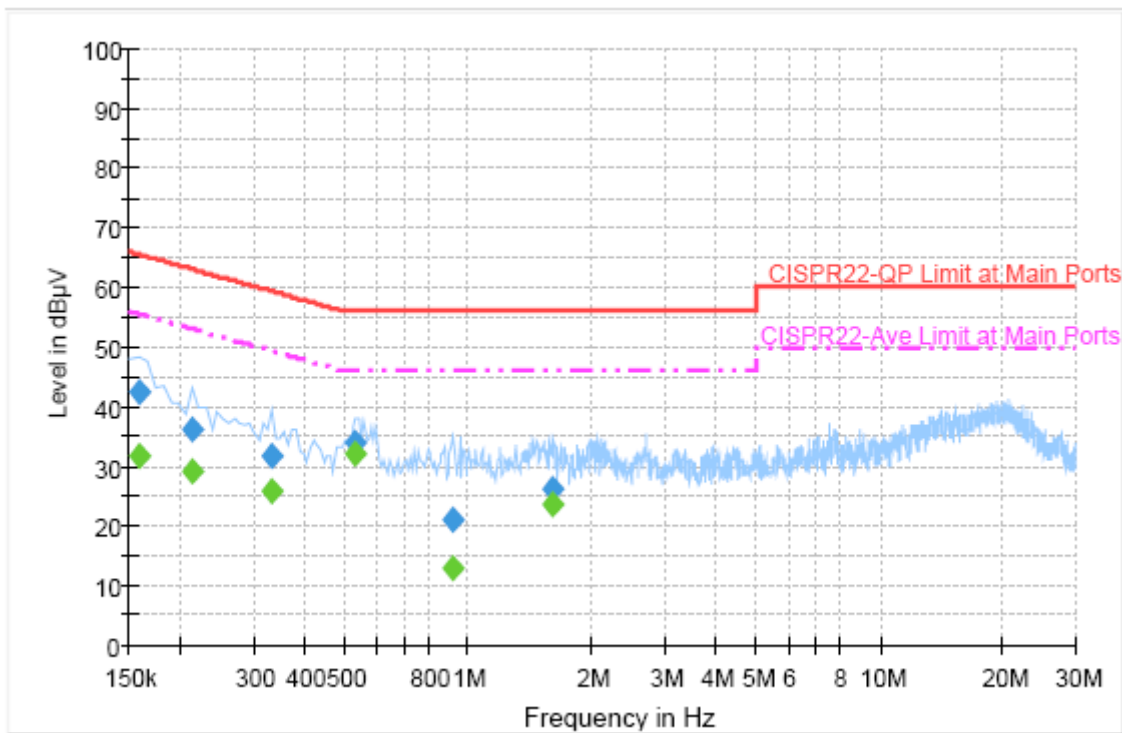

Final Result 1

Frequency (MHz)	QuasiPeak (dBμV)	Filter	Line	Corr. (dB)	Margin (dB)	Limit (dBμV)
0.158000	42.4	Off	L1	19.3	23.2	65.6
0.214000	36.3	Off	L1	19.3	26.7	63.0
0.334000	31.6	Off	L1	19.3	27.8	59.4
0.534000	34.0	Off	L1	19.3	22.0	56.0
0.918000	20.9	Off	L1	19.4	35.1	56.0
1.606000	26.3	Off	L1	19.4	29.7	56.0

Final Result 2

Frequency (MHz)	Average (dBμV)	Filter	Line	Corr. (dB)	Margin (dB)	Limit (dBμV)
0.158000	31.8	Off	L1	19.3	23.8	55.6
0.214000	29.3	Off	L1	19.3	23.7	53.0
0.334000	25.7	Off	L1	19.3	23.7	49.4
0.534000	32.1	Off	L1	19.3	13.9	46.0
0.918000	12.9	Off	L1	19.4	33.1	46.0
1.606000	23.6	Off	L1	19.4	22.4	46.0



Test Mode :	Mode 1	Temperature :	23~24
Test Engineer :	Cona Huang	Relative Humidity :	43~44%
		Phase :	Neutral
Function Type :	BT Link + Cradle + Adapter		
Remark :	All emissions not reported here are more than 10 dB below the prescribed limit.		

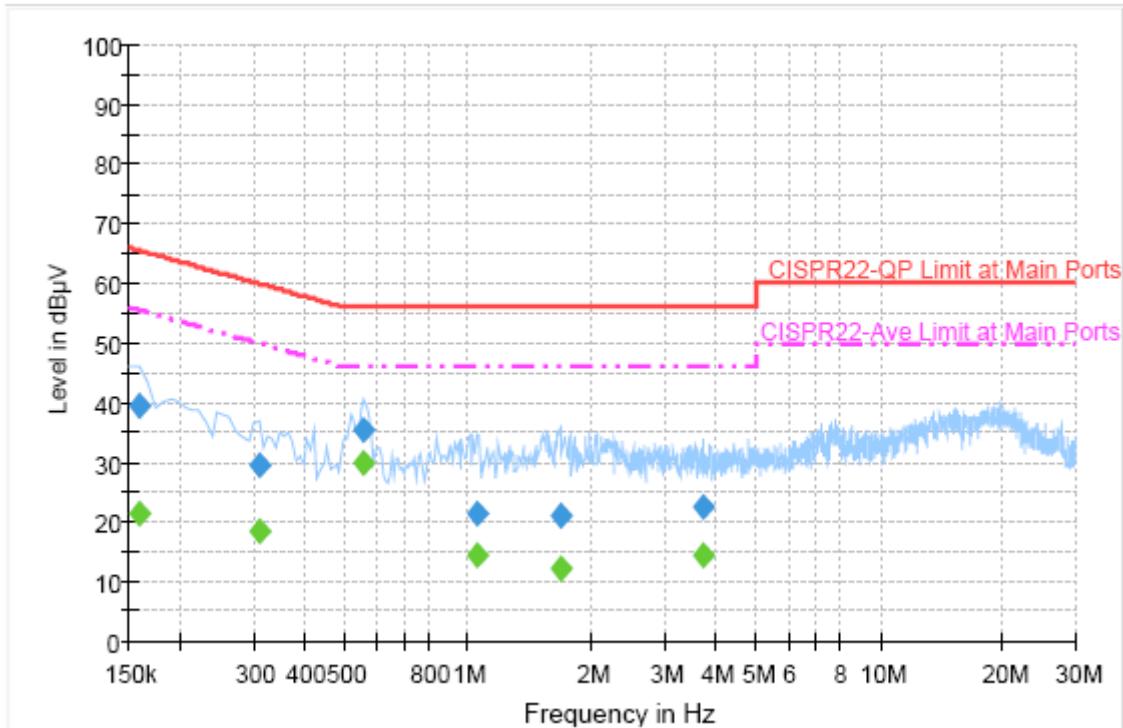

Final Result 1

Frequency (MHz)	QuasiPeak (dBµV)	Filter	Line	Corr. (dB)	Margin (dB)	Limit (dBµV)
0.158000	39.6	Off	N	19.4	26.0	65.6
0.310000	29.7	Off	N	19.3	30.3	60.0
0.558000	35.5	Off	N	19.3	20.5	56.0
1.054000	21.5	Off	N	19.4	34.5	56.0
1.670000	20.9	Off	N	19.5	35.1	56.0
3.734000	22.6	Off	N	19.6	33.4	56.0

Final Result 2

Frequency (MHz)	Average (dBµV)	Filter	Line	Corr. (dB)	Margin (dB)	Limit (dBµV)
0.158000	21.5	Off	N	19.4	34.1	55.6
0.310000	18.5	Off	N	19.3	31.5	50.0
0.558000	29.9	Off	N	19.3	16.1	46.0
1.054000	14.5	Off	N	19.4	31.5	46.0
1.670000	12.2	Off	N	19.5	33.8	46.0
3.734000	14.3	Off	N	19.6	31.7	46.0

3.8 Radiated Emission Measurement

3.8.1 Limit of Radiated Emission

In any 100 kHz bandwidth outside the intentional radiator frequency band, all harmonics/spurious must be at least 20 dB below the highest emission level within the authorized band. In addition, radiated emissions which fall in the restricted bands must also comply with the FCC section 15.209 limits as below.

Frequency (MHz)	Field Strength (microvolts/meter)	Measurement Distance (meters)
0.009 – 0.490	2400/F(kHz)	300
0.490 – 1.705	24000/F(kHz)	30
1.705 – 30.0	30	30
30 – 88	100	3
88 – 216	150	3
216 - 960	200	3
Above 960	500	3

3.8.2 Measuring Instruments

See list of measuring instruments of this test report.

3.8.3 Test Procedures

1. The testing follows the guidelines in FCC Public Notice DA 00-705 Measurement Guidelines.
2. Use the following spectrum analyzer settings:
Span = wide enough to fully capture the emission being measured; RBW = 1 MHz for $f \geq 1$ GHz, 100 kHz for $f < 1$ GHz; VBW \geq RBW; Sweep = auto; Detector function = peak; Trace = max hold.
3. Follow the guidelines in ANSI C63.4-2003 with respect to maximizing the emission by rotating the EUT, measuring the emission for three EUT orthogonal planes, and adjusting the measurement antenna height and polarization. A pre-amp and a high pass filter are used for this test in order to get the good signal level.

3.8.4 Test Setup

For radiated emissions below 30MHz

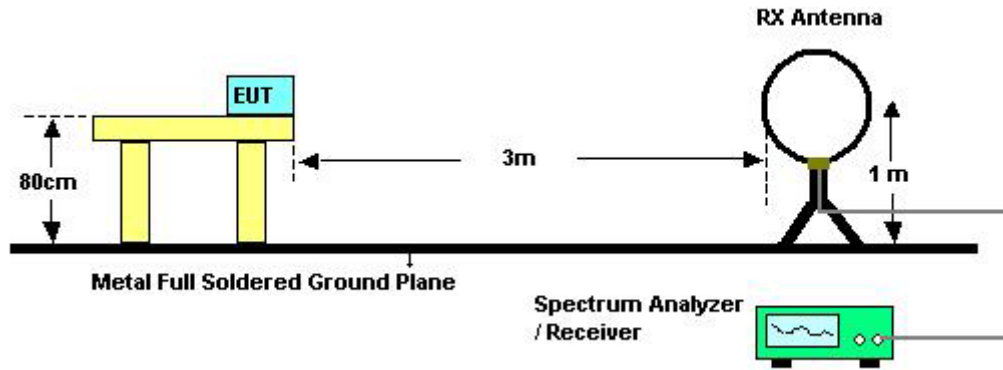

For radiated emissions above 30MHz

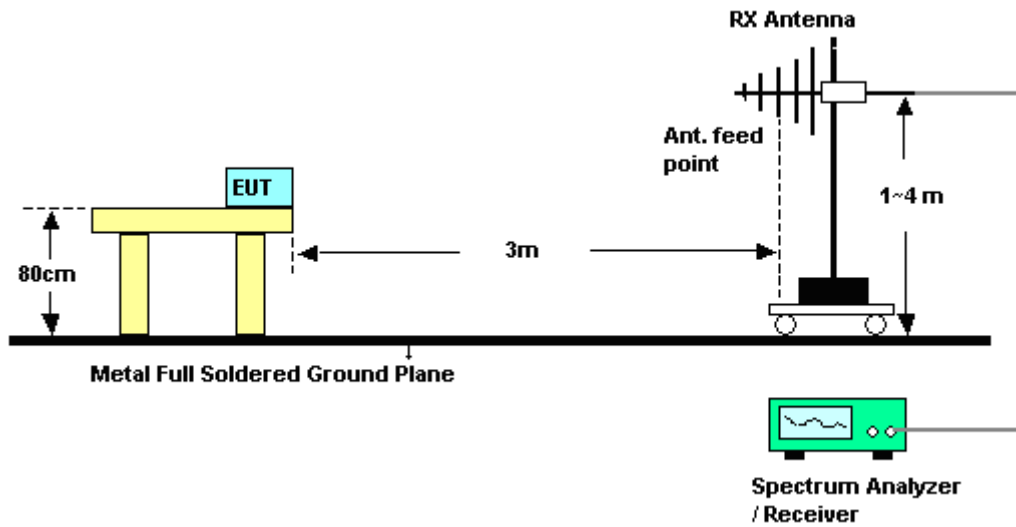



3.8.5 Test Results of Radiated Emissions (9kHz ~ 30MHz)

Temperature	24~26°C	Humidity	47~49%
Test Engineer	Elvis Chen		

Freq. (MHz)	Level (dBuV)	Over Limit (dB)	Limit Line (dBuV)	Remark
-	-	-	-	See Note

Note:

The amplitude of spurious emissions that are attenuated by more than 20dB below the permissible value has no need to be reported.

Distance extrapolation factor = $40 \log(\text{specific distance} / \text{test distance})$ (dB);

Limit line = specific limits (dBuV) + distance extrapolation factor.



3.8.6 Test Result of Radiated Emission (30MHz ~ 1GHz)

Test Mode :	Mode 1	Temperature :	24~26°C
Test Channel :	00	Relative Humidity :	47~49%
Test Engineer :	Elvis Chen	Polarization :	Horizontal
Remark :			

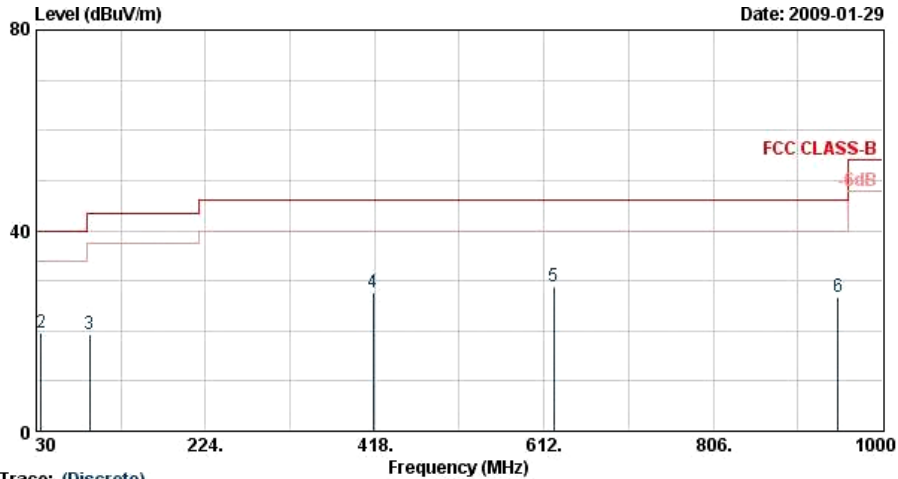

Site : 03CH07-HY
 Condition : FCC CLASS-B 3m LF-ANT(080228) HORIZONTAL
 Project : FR 912101

Power : Real Battery (4.18Vdc)

	Freq	Level	Over	Limit	ReadAntenna	Cable	Preamp	Ant	Table	Remark
	MHz	dBuV/m	dB	dBuV/m	dBuV	dB/m	dB	dB	cm	deg
1 @	30.00	29.31	-10.69	40.00	41.37	18.61	0.64	31.31	100	142 Peak
2	35.94	19.62	-20.38	40.00	34.97	15.14	0.69	31.17	---	---
3	91.02	19.47	-24.03	43.50	41.29	8.49	1.12	31.43	---	---
4	416.20	27.77	-18.23	46.00	40.30	16.11	2.64	31.29	---	---
5	623.40	28.88	-17.12	46.00	36.59	19.90	3.33	30.94	---	---
6	948.90	26.74	-19.26	46.00	29.24	23.99	4.26	30.75	---	---



Test Mode :	Mode 1	Temperature :	24~26°C
Test Channel :	00	Relative Humidity :	47~49%
Test Engineer :	Elvis Chen	Polarization :	Vertical
Remark :			

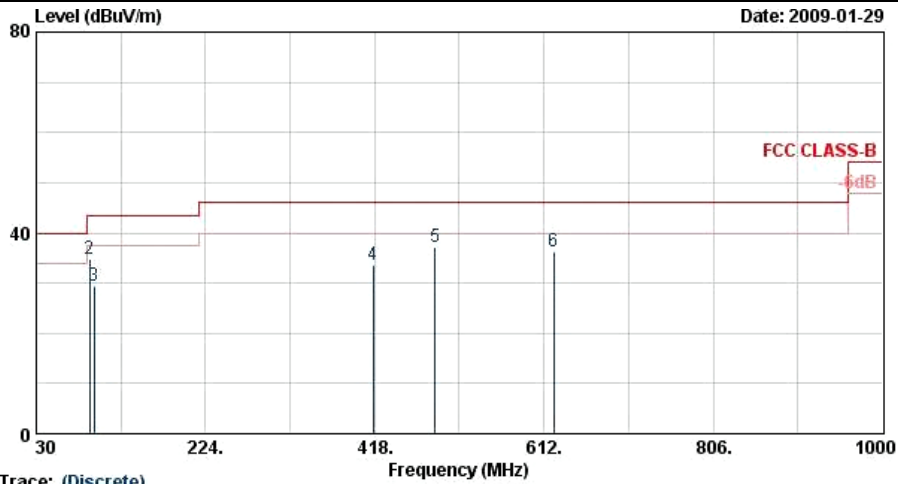

Site : 03CH07-HY
 Condition : FCC CLASS-B 3m LF-ANT(080228) VERTICAL
 Project : FR 912101

Power : Real Battery (4.18Vdc)

	Freq	Level	Over	Limit	ReadAntenna	Cable	Preamp	Ant	Table		
	MHz	dBuV/m	dB	dBuV/m	dBuV	dB	dB	cm	deg	Remark	
1 @	30.00	32.19	-7.81	40.00	44.25	18.61	0.64	31.31	100	41 Peak	
2 @	91.02	34.78	-8.72	43.50	56.60	8.49	1.12	31.43	---	---	Peak
3	96.42	29.49	-14.01	43.50	50.46	9.30	1.14	31.41	---	---	Peak
4	416.20	33.72	-12.28	46.00	46.25	16.11	2.64	31.29	---	---	Peak
5 @	486.90	37.07	-8.93	46.00	47.68	17.64	2.89	31.14	---	---	Peak
6 @	623.40	36.27	-9.73	46.00	43.98	19.90	3.33	30.94	---	---	Peak



Test Mode :	Mode 2	Temperature :	24~26°C
Test Channel :	39	Relative Humidity :	47~49%
Test Engineer :	Elvis Chen	Polarization :	Horizontal
Remark :			

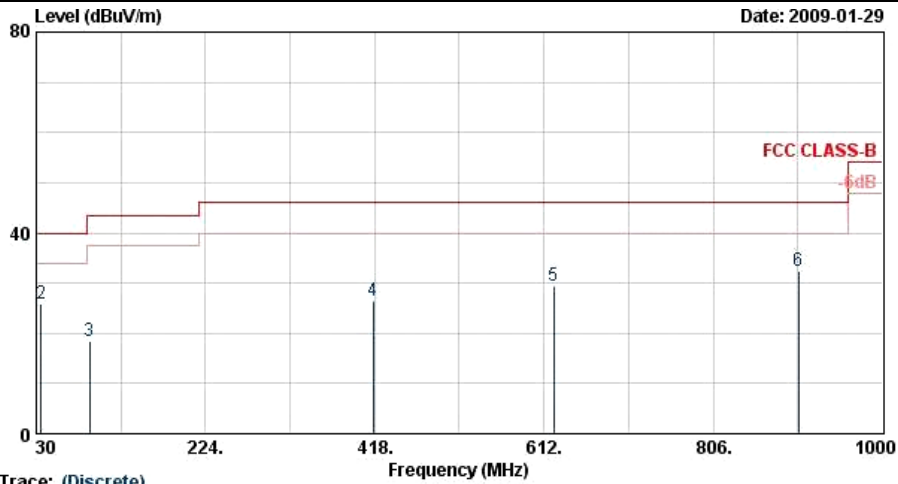

Trace: (Discrete)
 Site : 03CH07-HY
 Condition : FCC CLASS-B 3m LF-ANT(080228) HORIZONTAL
 Project : FR 912101

Power : Real Battery (4.18Vdc)

	Freq	Level	Over	Limit	ReadAntenna	Cable	Preamp	Ant	Table		
	MHz	dBuV/m	dB	dBuV/m	dBuV	Loss	Factor	Pos	Pos	Remark	
					dB/m	dB	dB	cm	deg		
1 !	30.00	35.98	-4.02	40.00	48.04	18.61	0.64	31.31	100	11 Peak	
2	35.94	25.76	-14.24	40.00	41.11	15.14	0.69	31.17	---	---	Peak
3	91.02	18.35	-25.15	43.50	40.17	8.49	1.12	31.43	---	---	Peak
4	416.20	26.38	-19.62	46.00	38.91	16.11	2.64	31.29	---	---	Peak
5	623.40	29.46	-16.54	46.00	37.17	19.90	3.33	30.94	---	---	Peak
6	903.40	32.44	-13.56	46.00	35.48	23.32	4.17	30.53	---	---	Peak



Test Mode :	Mode 2	Temperature :	24~26°C
Test Channel :	39	Relative Humidity :	47~49%
Test Engineer :	Elvis Chen	Polarization :	Vertical
Remark :			

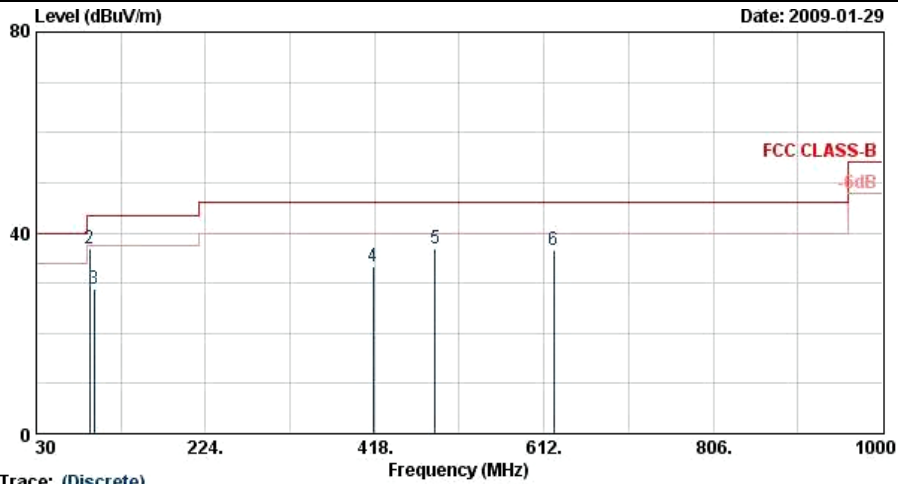

Trace: (Discrete)
 Site : 03CH07-HY
 Condition : FCC CLASS-B 3m LF-ANT(080228) VERTICAL
 Project : FR 912101

Power : Real Battery (4.18Vdc)

	Freq	Level	Over	Limit	ReadAntenna	Cable	Preamp	Ant	Table		
	MHz	dBuV/m	dB	dBuV/m	dBuV	dB	dB	cm	deg	Remark	
1 !	30.00	35.10	-4.90	40.00	47.16	18.61	0.64	31.31	100	274 Peak	
2	91.02	36.97	-6.53	43.50	58.79	8.49	1.12	31.43	---	---	Peak
3	96.42	28.79	-14.71	43.50	49.76	9.30	1.14	31.41	---	---	Peak
4	416.20	33.37	-12.63	46.00	45.90	16.11	2.64	31.29	---	---	Peak
5	486.90	37.01	-8.99	46.00	47.62	17.64	2.89	31.14	---	---	Peak
6	623.40	36.66	-9.34	46.00	44.37	19.90	3.33	30.94	---	---	Peak



Test Mode :	Mode 3	Temperature :	24~26°C
Test Channel :	78	Relative Humidity :	47~49%
Test Engineer :	Elvis Chen	Polarization :	Horizontal
Remark :			

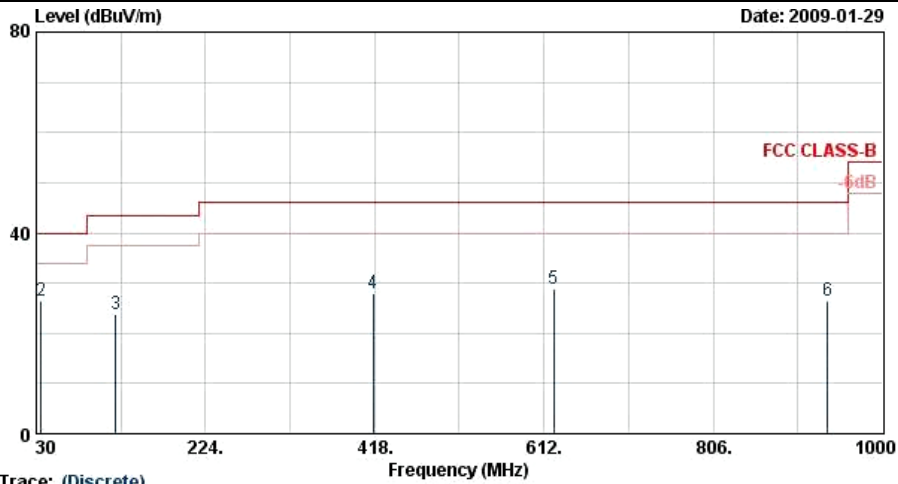

Trace: (Discrete)
 Site : 03CH07-HY
 Condition : FCC CLASS-B 3m LF-ANT(080228) HORIZONTAL
 Project : FR 912101

Power : Real Battery (4.18Vdc)

	Freq	Level	Over	Limit	ReadAntenna	Cable	Preamp	Ant	Table	
	MHz	dBuV/m	dB	dBuV/m	dBuV	Loss	Factor	Pos	Pos	Remark
					dB/m	dB	dB	cm	deg	
1 @	30.00	34.31	-5.69	40.00	46.37	18.61	0.64	31.31	117	Peak
2	35.94	26.60	-13.40	40.00	41.95	15.14	0.69	31.17	---	Peak
3	121.26	23.71	-19.79	43.50	42.53	11.29	1.29	31.40	---	Peak
4	416.20	27.81	-18.19	46.00	40.34	16.11	2.64	31.29	---	Peak
5	623.40	28.91	-17.09	46.00	36.62	19.90	3.33	30.94	---	Peak
6	937.00	26.60	-19.40	46.00	29.24	23.82	4.23	30.69	---	Peak



Test Mode :	Mode 3	Temperature :	24~26°C
Test Channel :	78	Relative Humidity :	47~49%
Test Engineer :	Elvis Chen	Polarization :	Vertical
Remark :			

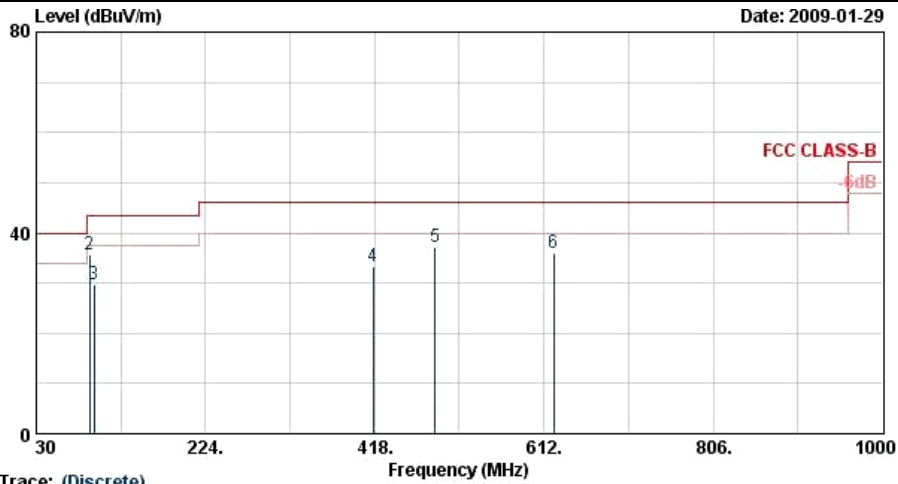

Trace: (Discrete)
 Site : 03CH07-HY
 Condition : FCC CLASS-B 3m LF-ANT(080228) VERTICAL
 Project : FR 912101

Power : Real Battery (4.18Vdc)

	Freq	Level	Over	Limit	ReadAntenna	Cable	Preamp	Ant	Table		
	MHz	dBuV/m	dB	dBuV/m	dBuV	dB	dB	cm	deg	Remark	
1 @	30.00	35.46	-4.54	40.00	47.52	18.61	0.64	31.31	100	75 Peak	
2	91.02	35.61	-7.89	43.50	57.43	8.49	1.12	31.43	---	---	Peak
3	96.42	29.79	-13.71	43.50	50.76	9.30	1.14	31.41	---	---	Peak
4	416.20	33.38	-12.62	46.00	45.91	16.11	2.64	31.29	---	---	Peak
5	486.90	37.29	-8.71	46.00	47.90	17.64	2.89	31.14	---	---	Peak
6	623.40	36.10	-9.90	46.00	43.81	19.90	3.33	30.94	---	---	Peak



3.8.7 Test Result of Radiated Emission ≥ 1 GHz

Test Mode :	Mode 1	Temperature :	24~26°C
Test Channel :	00	Relative Humidity :	47~49%
Test Engineer :	Elvis Chen	Polarization :	Horizontal
Remark :	#3 and #4 are Fundamental Signals		

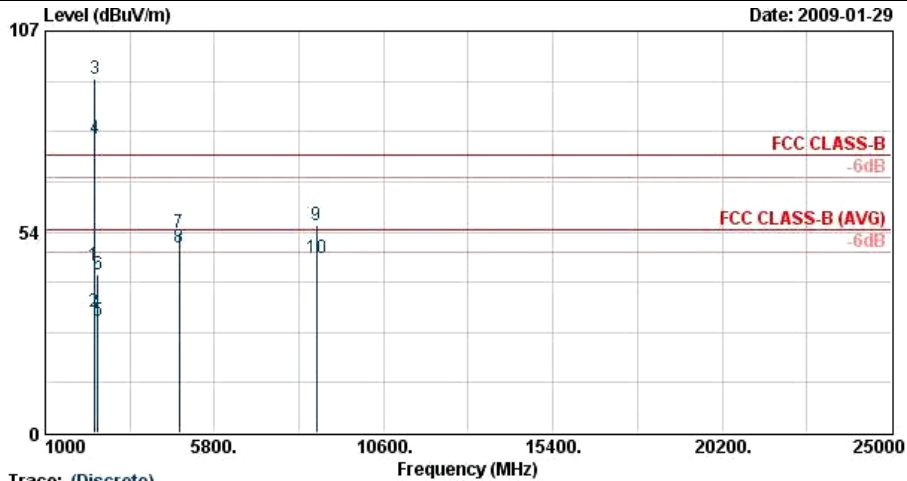

Site : 03CH07-HY
 Condition : FCC CLASS-B 3m SHF-EHF HORN HORIZONTAL
 Project : FR.912101

Power : Real Battery (4.18Vdc)

	Freq	Level	Over	Limit	ReadAntenna	Cable	Preamp	Ant	Table	Remark
	MHz	dBuV/m	dB	dBuV/m	dBuV	dB/m	dB	dB	cm	deg
1	2385.81	44.71	-29.29	74.00	42.61	32.32	5.46	35.68	100	0 Peak
2	2385.81	32.21	-21.79	54.00	30.11	32.32	5.46	35.68	100	234 Average
3 @	2402.00	94.34			92.26	32.32	5.44	35.68	100	0 Peak
4 @	2402.00	78.41			76.31	32.32	5.46	35.68	100	234 Average
5	2486.00	29.84	-24.16	54.00	27.85	32.30	5.38	35.70	100	234 Average
6	2486.00	42.28	-31.72	74.00	40.29	32.30	5.38	35.70	100	0 Peak
7	4806.00	53.35	-20.65	74.00	45.66	35.57	7.79	35.68	100	0 Peak
8 @	4806.00	49.18	-4.82	54.00	41.49	35.57	7.79	35.68	100	54 Average
9	8697.00	55.27	-18.73	74.00	42.92	38.52	10.24	36.42	100	0 Peak
10 @	8697.00	46.61	-7.39	54.00	34.27	38.52	10.24	36.42	100	221 Average



Test Mode :	Mode 1	Temperature :	24~26°C
Test Channel :	00	Relative Humidity :	47~49%
Test Engineer :	Elvis Chen	Polarization :	Vertical
Remark :	#3 and #4 are Fundamental Signals		

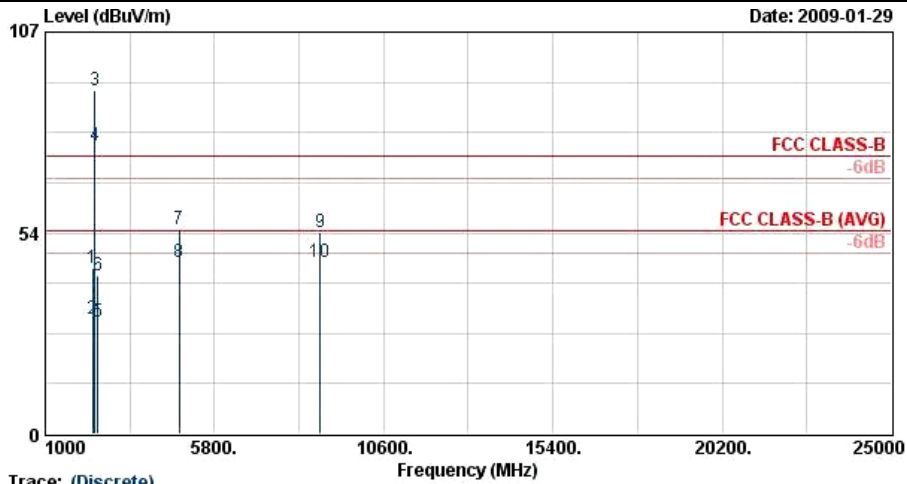

Site : 03CH07-HY
 Condition : FCC CLASS-B 3m SHF-EHF HORN VERTICAL
 Project : FR 912101

Power : Real Battery (4.18Vdc)

	Freq	Level	Over	Limit	ReadAntenna	Cable	Preamp	Ant	Table	
	MHz	dBuV/m	dB	dBuV/m	dBuV	dB	dB	cm	deg	Remark
1	2353.70	44.28	-29.72	74.00	42.16	32.30	5.49	35.67	100	44 Peak
2	2353.70	30.47	-23.53	54.00	28.35	32.30	5.49	35.67	100	44 Average
3 @	2402.00	91.55			89.49	32.30	5.44	35.68	100	44 Peak
4 @	2402.00	76.94			74.86	32.30	5.46	35.68	100	44 Average
5	2484.00	29.87	-24.13	54.00	27.88	32.30	5.38	35.70	100	44 Average
6	2484.00	42.14	-31.86	74.00	40.15	32.30	5.38	35.70	100	44 Peak
7	4806.00	54.41	-19.59	74.00	47.33	34.96	7.79	35.68	100	119 Peak
8 @	4806.00	45.86	-8.14	54.00	38.78	34.96	7.79	35.68	100	119 Average
9	8793.00	53.73	-20.27	74.00	42.47	37.47	10.27	36.48	100	115 Peak
10 @	8793.00	45.93	-8.07	54.00	34.67	37.47	10.27	36.48	100	115 Average



Test Mode :	Mode 2	Temperature :	24~26°C
Test Channel :	39	Relative Humidity :	47~49%
Test Engineer :	Elvis Chen	Polarization :	Horizontal
Remark :	#3 and #4 are Fundamental Signals		

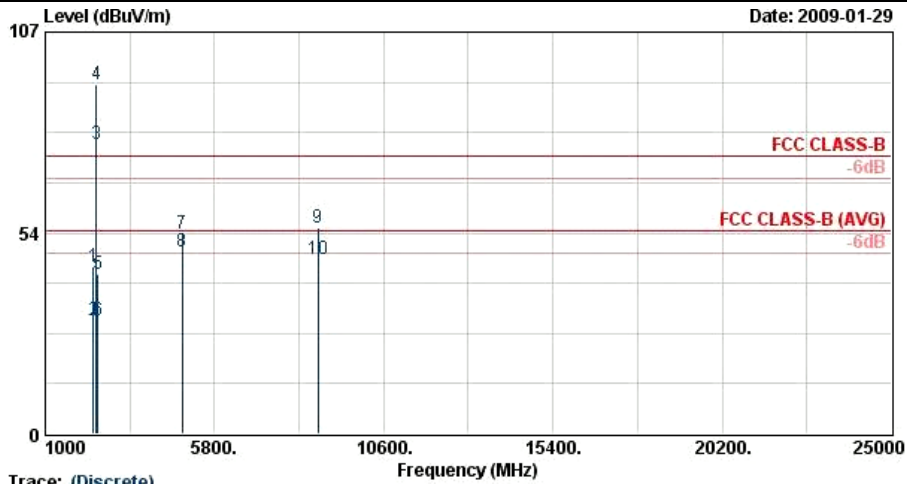

Trace: (Discrete)

Site : 03CH07-HY
 Condition : FCC CLASS-B 3m SHF-EHF HORN HORIZONTAL
 Project : FR 912101

Power : Real Battery (4.18Vdc)

	Freq	Level	Over	Limit	ReadAntenna	Cable	Preamp	Ant	Table	
	MHz	dBuV/m	dB	dBuV/m	dBuV	dB	dB	cm	deg	Remark
1	2366.00	44.45	-29.55	74.00	42.31	32.33	5.49	35.68	100	0 Peak
2	2366.00	30.36	-23.64	54.00	28.22	32.33	5.49	35.68	100	232 Average
3 X	2441.00	77.17			75.14	32.31	5.41	35.69	100	232 Average
4 X	2441.00	93.14			91.10	32.31	5.41	35.69	100	0 Peak
5	2484.00	42.65	-31.35	74.00	40.66	32.30	5.38	35.70	100	0 Peak
6	2484.00	30.03	-23.97	54.00	28.04	32.30	5.38	35.70	100	232 Average
7	4881.00	53.40	-20.60	74.00	45.55	35.66	7.85	35.65	100	0 Peak
8 !	4881.00	48.35	-5.65	54.00	40.49	35.66	7.85	35.65	100	57 Average
9	8730.00	54.78	-19.22	74.00	42.42	38.54	10.25	36.44	100	0 Peak
10	8730.00	46.51	-7.49	54.00	34.15	38.54	10.25	36.44	100	12 Average



Test Mode :	Mode 2	Temperature :	24~26°C
Test Channel :	39	Relative Humidity :	47~49%
Test Engineer :	Elvis Chen	Polarization :	Vertical
Remark :	#3 and #4 are Fundamental Signals		

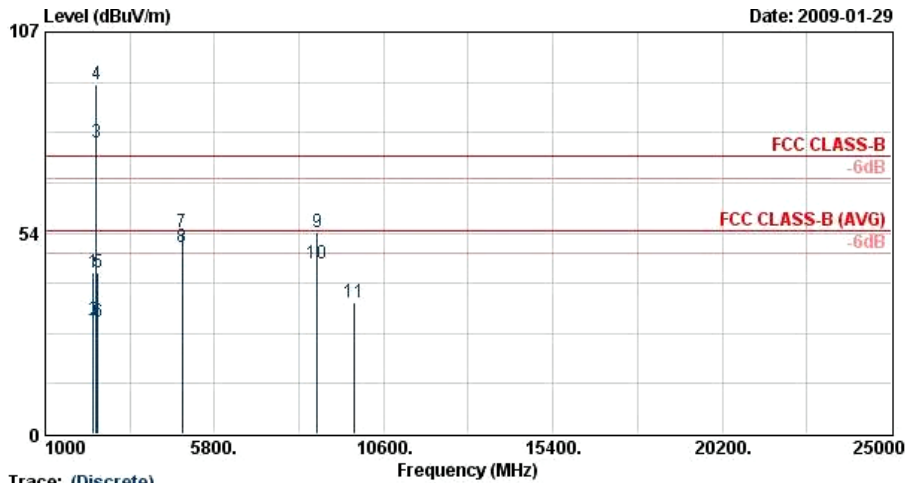

Trace: (Discrete)

Site : 03CHO7-HY
 Condition : FCC CLASS-B 3m SHF-EHF HORN VERTICAL
 Project : FR 912101

Power : Real Battery (4.18Vdc)

	Freq	Level	Over	Limit	Read	Antenna	Cable	Preamp	Ant	Table	Remark
	MHz	dBuV/m	Limit	Line	Level	Factor	Loss	Factor	Pos	Pos	
			dB	dBuV/m	dBuV	dB/m	dB	dB	cm	deg	
1	2356.00	43.16	-30.84	74.00	41.04	32.30	5.49	35.67	100	0	Peak
2	2356.00	30.21	-23.79	54.00	28.09	32.30	5.49	35.67	100	36	Average
3 @	2441.00	77.51			75.49	32.30	5.41	35.69	100	36	Average
4 X	2441.00	92.97			90.95	32.30	5.41	35.69	100	0	Peak
5	2494.00	42.77	-31.23	74.00	40.80	32.30	5.37	35.70	100	0	Peak
6	2494.00	30.00	-24.00	54.00	28.03	32.30	5.37	35.70	100	36	Average
7	4881.00	53.85	-20.15	74.00	46.67	34.98	7.85	35.65	100	0	Peak
8 !	4881.00	49.84	-4.16	54.00	42.66	34.98	7.85	35.65	100	67	Average
9	8709.00	53.74	-20.26	74.00	42.50	37.42	10.24	36.42	100	0	Peak
10	8709.00	45.42	-8.58	54.00	34.18	37.42	10.24	36.42	100	351	Average
11	9762.00	34.91	-39.09	74.00	70.67	-9.83	10.82	36.76	100	0	Peak



Test Mode :	Mode 3	Temperature :	24~26°C
Test Channel :	78	Relative Humidity :	47~49%
Test Engineer :	Elvis Chen	Polarization :	Horizontal
Remark :	#3 and #4 are Fundamental Signals		

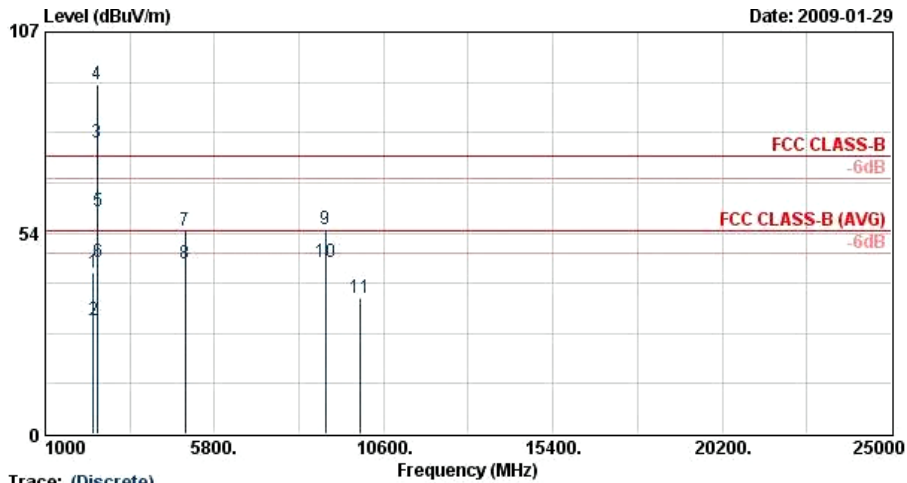

Trace: (Discrete)
 Site : 03CHO7-HY
 Condition : FCC CLASS-B 3m SHF-EHF HORN HORIZONTAL
 Project : FR 912101

Power : Real Battery (4.18Vdc)

	Freq	Level	Over	Limit	Read	Antenna	Cable	Preamp	Ant	Table	Remark
	MHz	dBuV/m	Limit	Line	Level	Factor	Loss	Factor	Pos	Pos	
			dB	dBuV/m	dBuV	dB/m	dB	dB	cm	deg	
1	2366.00	42.85	-31.15	74.00	40.71	32.33	5.49	35.68	100	229	Peak
2	2366.00	30.36	-23.64	54.00	28.22	32.33	5.49	35.68	102	229	Average
3 @	2480.00	77.69			75.70	32.30	5.38	35.70	102	229	Average
4 @	2480.00	93.01			91.01	32.30	5.38	35.70	100	229	Peak
5	2483.50	59.20	-14.80	74.00	57.21	32.30	5.38	35.70	100	229	Peak
6	2483.50	45.74	-8.26	54.00	43.75	32.30	5.38	35.70	102	229	Average
7	4962.00	54.00	-20.00	74.00	45.94	35.76	7.92	35.62	100	53	Peak
8	4962.00	45.24	-8.76	54.00	37.18	35.76	7.92	35.62	100	53	Average
9	8949.00	54.38	-19.62	74.00	41.96	38.67	10.32	36.57	100	100	Peak
10	8949.00	45.60	-8.40	54.00	33.18	38.67	10.32	36.57	100	100	Average
11	9918.00	36.28	-37.72	74.00	71.59	-9.48	10.95	36.79	100	39	Peak



Test Mode :	Mode 3	Temperature :	24~26°C
Test Channel :	78	Relative Humidity :	47~49%
Test Engineer :	Elvis Chen	Polarization :	Vertical
Remark :	#3 and #4 are Fundamental Signals		

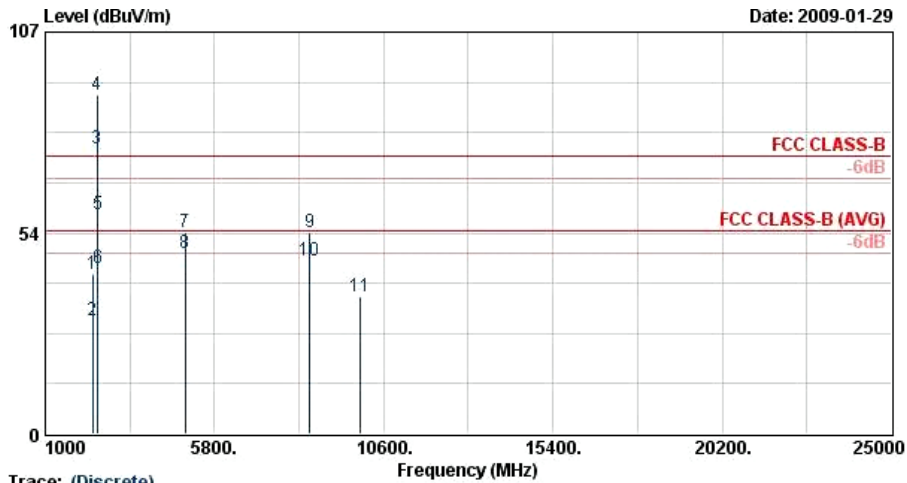

Trace: (Discrete)
 Site : 03CHO7-HY
 Condition : FCC CLASS-B 3m SHF-EHF HORN VERTICAL
 Project : FR 912101

Power : Real Battery (4.18Vdc)

	Freq	Level	Over	Limit	Read	Antenna	Cable	Preamp	Ant	Table	Remark
	MHz	dBuV/m	Limit	Line	Level	Factor	Loss	Factor	Pos	Pos	
			dB	dBuV/m	dBuV	dB/m	dB	dB	cm	deg	
1	2334.00	42.69	-31.31	74.00	40.54	32.30	5.51	35.67	100		0 Peak
2	2334.00	30.20	-23.80	54.00	28.05	32.30	5.51	35.67	100		37 Average
3 @	2480.00	75.91			73.92	32.30	5.38	35.70	100		37 Average
4 @	2480.00	90.46			88.47	32.30	5.38	35.70	100		0 Peak
5	2483.50	58.51	-15.49	74.00	56.52	32.30	5.38	35.70	100		0 Peak
6	2483.50	44.30	-9.70	54.00	42.31	32.30	5.38	35.70	100		37 Average
7	4962.00	53.69	-20.31	74.00	46.39	34.99	7.92	35.62	100		0 Peak
8 !	4962.00	48.12	-5.88	54.00	40.83	34.99	7.92	35.62	100		64 Average
9	8502.00	53.87	-20.13	74.00	42.69	37.30	10.18	36.30	100		0 Peak
10	8502.00	46.16	-7.84	54.00	34.98	37.30	10.18	36.30	100		157 Average
11	9918.00	36.70	-37.30	74.00	72.01	-9.48	10.95	36.79	100		0 Peak



3.9 Antenna Requirements

3.9.1 Standard Applicable

If directional gain of transmitting antennas is greater than 6dBi, the power shall be reduced by the same level in dB comparing to gain minus 6dBi.

The use of a permanently attached antenna or of an antenna that uses a unique coupling to the intentional radiator shall be considered sufficient to comply with the FCC rule.

3.9.2 Antenna Connected Construction

The antennas type used in this product is Chip Antenna without connector and it is considered to meet antenna requirement.

3.9.3 Antenna Gain

The antenna peak gain of EUT is less than 6 dBi. Therefore, it is not necessary to reduce maximum peak output power limit.



4 List of Measuring Equipments

Instrument	Manufacturer	Model No.	Serial No.	Characteristics	Calibration Date	Due Date	Remark
Spectrum Analyzer	R&S	FSP40	100055	9kHz~40GHz	Jun. 26, 2008	Jun. 25, 2009	Conducted (TH02-HY)
Power Meter	Agilent	E4416A	GB41292344	N/A	Feb. 21, 2008	Feb. 20, 2009	Conducted (TH02-HY)
Power Sensor	Agilent	E9327A	US40441548	N/A	Feb. 21, 2008	Feb. 20, 2009	Conducted (TH02-HY)
EMI Receiver	R&S	ESCS 30	100356	9kHz~2.75GHz	Aug. 01, 2008	Jul. 31, 2009	Conduction (CO05-HY)
Two-LISN	R&S	ENV216	11-100081	9kHz~30MHz	Nov. 26, 2008	Nov. 25, 2009	Conduction (CO05-HY)
Two-LISN	R&S	ENV216	11-100080	9kHz~30MHz	Nov. 26, 2008	Nov. 25, 2009	Conduction (CO05-HY)
AC Power Source	APC	APC-1000W	N/A	N/A	N/A	N/A	Conduction (CO05-HY)
Bilog Antenna	SCHAFFNER	CBL6111C	2726	30MHz~1GHz	Nov. 20, 2008	Nov. 19, 2009	Radiation (03CH07-HY)
Spectrum Analyzer	R&S	FSP	101067	9kHz~30GHz	Dec. 02, 2008	Dec. 01, 2009	Radiation (03CH07-HY)
Double Ridge Horn Antenna	ESCO	3117	75962	1G~18GHz	Aug. 13, 2008	Aug. 12, 2009	Radiation (03CH07-HY)
Pre Amplifier	Agilent	8449B	3008A02362	1G~26.5GHz	Dec. 17, 2008	Dec. 16, 2009	Radiation (03CH07-HY)
Pre Amplifier	COM-POWER	PA-103A	161241	10~1000MHz. 32dB.GAIN	Mar. 31, 2008	Mar. 30, 2009	Radiation (03CH07-HY)
Double Ridge Horn Antenna	ESCO	3117	66584	1G~18GHz	Aug. 06, 2008	Aug. 05, 2009	Radiation (03CH07-HY)
BT Base Station	Anritsu	MT8852B	6K00005722	N/A	Oct. 23, 2007	Oct. 22, 2009	Radiation (03CH07-HY)
Loop Antenna	R&S	HFH2-Z2	860004/001	9 kHz~30 MHz	May 22, 2008	May 21, 2010	Radiation (03CH07-HY)

5 Uncertainty of Evaluation

Uncertainty of Conducted Emission Measurement (150kHz ~ 30MHz)

Contribution	Uncertainty of x_i		$u(x_i)$
	dB	Probability Distribution	
Receiver reading	0.10	Normal(k=2)	0.05
Cable loss	0.10	Normal(k=2)	0.05
AMN insertion loss	2.50	Rectangular	0.63
Receiver Spec	1.50	Rectangular	0.43
Site imperfection	1.39	Rectangular	0.80
Mismatch	+0.34/-0.35	U-shape	0.24
Combined standard uncertainty Uc(y)	1.13		
Measuring uncertainty for a level of confidence of 95% U=2Uc(y)	2.26		

Uncertainty of Radiated Emission Measurement (30MHz ~ 1000MHz)

Contribution	Uncertainty of x_i		$u(x_i)$
	dB	Probability Distribution	
Receiver reading	0.41	Normal(k=2)	0.21
Antenna factor calibration	0.83	Normal(k=2)	0.42
Cable loss calibration	0.25	Normal(k=2)	0.13
Pre Amplifier Gain calibration	0.27	Normal(k=2)	0.14
RCV/SPA specification	2.50	Rectangular	0.72
Antenna Factor Interpolation for Frequency	1.00	Rectangular	0.29
Site imperfection	1.43	Rectangular	0.83
Mismatch	+0.39/-0.41	U-shaped	0.28
Combined standard uncertainty Uc(y)	1.27		
Measuring uncertainty for a level of confidence of 95% U=2Uc(y)	2.54		



Uncertainty of Radiated Emission Measurement (1GHz ~ 40GHz)

Contribution	Uncertainty of x_i		$u(x_i)$	C_i	$C_i * u(x_i)$
	dB	Probability Distribution			
Receiver reading	±0.10	Normal(k=1)	0.10	1	0.10
Antenna factor calibration	±1.70	Normal(k=2)	0.85	1	0.85
Cable loss calibration	±0.50	Normal(k=2)	0.25	1	0.25
Receiver Correction	±2.00	Rectangular	1.15	1	1.15
Antenna Factor Directional	±1.50	Rectangular	0.87	1	0.87
Site imperfection	±2.80	Triangular	1.14	1	1.14
Mismatch Receiver VSWR $\Gamma_1 = 0.197$ Antenna VSWR $\Gamma_2 = 0.194$ Uncertainty = $20 \log(1 - \Gamma_1 * \Gamma_2)$	+0.34/-0.35	U-shaped	0.244	1	0.244
Combined standard uncertainty $U_c(y)$	2.36				
Measuring uncertainty for a level of confidence of 95% $U = 2U_c(y)$	4.72				

6 Certification of TAF Accreditation



Certificate No. : L1190-081212

財團法人全國認證基金會
Taiwan Accreditation Foundation

Certificate of Accreditation

This is to certify that

Sporton International Inc.
EMC & Wireless Communications Laboratory
No.52, Hwa Ya 1st Rd., Hwa Ya Technology Park, Kwei-Shan Hsiang, Tao Yuan Hsien,
Taiwan, R.O.C.

is accredited in respect of laboratory

Accreditation Criteria	: ISO/IEC 17025:2005
Accreditation Number	: 1190
Originally Accredited	: December 15, 2003
Effective Period	: January 10, 2007 to January 09, 2010
Accredited Scope	: Testing Field, see described in the Appendix
Specific Accreditation Program	: Accreditation Program for Designated Testing Laboratory for Commodities Inspection Accreditation Program for Telecommunication Equipment Testing Laboratory Accreditation Program for BSMI Mutual Recognition Arrangement with Foreign Authorities

Jay-San Chen
President, Taiwan Accreditation Foundation
Date : December 12, 2008

PI, total 18 pages

The Appendix forms an integral part of this Certificate, which shall be invalid when use without the Appendix



Appendix A. Photographs of EUT

Please refer to Sporton report number EP912101 as below.