

# EMI TEST REPORT

**Test Report No. : 22DE0036-YW-2**

**Applicant: DENSO WAVE INCORPORATED**

**Type of Equipment: BARCODE HANDY TERMINAL**

**Model No.: BHT-100BF / BHT-100QF**

**FCC ID: PZWBHT-100F**

**Test standard: FCC Part15 Subpart C, Section 15.247**

**Test Result: Complied**

This report may not be reproduced in full, partial reproduction may only be made with the written consent of the laboratory.

The results in this report apply only to the sample tested.

**Date of test:** November 26-29, 2001      **Issued date:** January 10, 2002

**Tested by:** 

Naoki Sakamoto  
Group Leader of EMC section

**Approved by:** 

Kazutoyo Nakanishi  
Site Operation Manager of EMC section

---

**A-pex International Co., Ltd.**

**YOKOWA LAB.**

108 Yokowa-cho, Ise-shi, Mie-ken 516-1106 JAPAN

Telephone: int +81 596 39 1485

Facsimile: int +81 596 39 0232

<b>Table of Contents</b>	<b>Page</b>
<b>1 GENERAL INFORMATION</b>	<b>3</b>
1.1 Tested Methodology	4
1.2 Test Facility	4
<b>2 PRODUCT DESCRIPTION</b>	<b>5</b>
2.1 Test system Details	5
<b>3 SYSTEM TEST CONFIGURATION</b>	<b>7</b>
3.1 Justification	7
3.2. Configuration of Tested System	7
<b>4 MEASUREMENT UNCERTAINTY</b>	<b>8</b>
<b>5 TEST INSTRUMENTS</b>	<b>9</b>
<b>6 SUMMARY OF TEST</b>	<b>10</b>
6.1 §15.207 Conducted Emissions	10
6.2 §15.247(a)(1) Frequency Hopping Systems	10
6.3 §15.247(a)(1)(ii) Channel Utilization	11
6.4 §15.247(b) Maximum Peak Out Put Power(Radiated)	12
6.5 §15.247(b) Maximum Peak Out Put Power(Conducted)	12
6.6 §15.247(c) Out of Band Emissions(Radiated)	13
6.7 §15.247(c) Out of Band Emissions(Conducted)	13
Photographs of test setup	14-17
<b>APPENDIX</b>	<b>18</b>
Test data	A1toA63

## 1 GENERAL INFORMATION

APPLICANT : DENSO WAVE INCORPORATED

ADDRESS : 1-1, Showa-cho, Kariya-shi, Aichi-ken, 448-8661 Japan  
TEL : 81-566-61-4084  
FAX : 81-566-61-4741

REGULATION(S) : FCC Part15 Subpart C, Section 15.247

MODEL NUMBER : BHT-100BF / BHT-100QF

SERIAL NUMBER : 5496310181100005 : BHT-100BF  
5496900011100028 : BHT-100QF

KIND OF EQUIPMENT : BARCODE HANDY TERMINAL

TESTED DATE : November 26-29, 2001

RECEIPT DATE OF SAMPLE : November 26, 2001

REPORT FILE NUMBER : 22DE0036-YW-2

TEST SITE : A-PEX Yokowa No.3 Open Test Sites

---

**A-pex International Co., Ltd.**  
**YOKOWA LAB.**

108 Yokowa-cho, Ise-shi, Mie-ken 516-1106 JAPAN

Telephone: int +81 596 39 1485

Facsimile: int +81 596 39 0232

Test report  
FCC ID : PZWBHT-100F  
Our reference : 22DE0036-YW-2  
Page : 4 of 18  
Issued date : January 10, 2002

## 1.1 Tested Methodology

The measurement was performed according to the procedures in ANSI C63.4(1992).

## 1.2 Test Facility

The open area site measurement facilities used to collect the radiated data are located at 108, Yokowa-cho, Ise-shi, Mie-ken, 516-1106 Japan.

These sites have been fully described in reports submitted to the FCC office.

No.1 and No.3 test site has filed to the FCC on September 12, 2000 as number: 90412 and is accepted by Industry Canada on May 01, 2001 as number IC2973-3.

---

**A-pex International Co., Ltd.**

**YOKOWA LAB.**

108 Yokowa-cho, Ise-shi, Mie-ken 516-1106 JAPAN

Telephone: int +81 596 39 1485

Facsimile: int +81 596 39 0232

## 2 PRODUCT DESCRIPTION

Denso Wave Incorporation, Model BHT-100BF/BHT-100QF (referred to as the EUT in this report) is a Wireless Module built in Barcode Handy Terminal.

Barcode Handy Terminal, model: BHT-100BF and model: BHT-100QF are the family models.  
The difference of these two models is:  
BHT-100QF is a two-dimensional code model.  
BHT-100BF is a type dedicated for barcode.  
There is no other difference between them.

The specification is as following :

### Wireless Module

Model No. : PROXIM RangeLAN2 633002CE-US  
Frequency characteristics : 2402MHz through 2480MHz  
No. of channels / channel spacing : 79 channels / 1MHz channel spacing  
Modulation : Low power Frequency Hopping Spread Spectrum(FHSS)  
Antenna type : Integral, M/N:YOKOWO YCE-5208  
Antenna Gain : 0dBi

### \*FccPart15.203 Antenna requirement

Wireless Module and its antenna comply with this requirement since they are built in host device BHT-100BF/BHT-100QF when they are put up for sale and they are used with a particular antenna connector(MMCX).

## 2.1 Test System Details

### Description of EUT and support equipment

No.	Item	Model number	Serial number	Manufacturer	Remark (FCC ID)
A	Barcode Handy Terminal	BHT-100BF or BHT-100QF	5496310181100005	Denso Wave	PZWBHT-100F (EUT)
			5496900011100028	Denso Wave	
B	Access Point	7520	752005-02600011	Proxim	IMK-AP II 1121
C	AC Adaptor for Access Point	SA-121A2F-11	002414	Proxim	-
D	Optical Communication Unit	CU-7001	4963201160000007	Denso Wave	DOC
E	AC Adaptor for Optical Communication Unit	-	496460-0381	Denso Wave	DOC
F	Personal Computer	MMM	S2BKC	DELL	E2KSTNGRMT
G	CRT Monitor	66-95361	6546-6BN(A)	IBM	-
H	Printer	C3990A	JPHL021975	Hewlett Packard	DOC
I	Modem	MC1400Fxe	-	Micro Core	-
J	Keyboard	SK-D100M	K9412-040116	DELL	GYUM93SK
K	Mouse	90741	02197737	Microsoft	C3KKMp3
L	AC Adaptor for Modem	MC1400Fxe	-	Micro Core	-

---

**A-pex International Co., Ltd.**

**YOKOWA LAB.**

108 Yokowa-cho, Ise-shi, Mie-ken 516-1106 JAPAN

Telephone: int +81 596 39 1485

Facsimile: int +81 596 39 0232

Test report  
FCC ID : PZWBHT-100F  
Our reference : 22DE0036-YW-2  
Page : 6 of 18  
Issued date : January 10, 2002

**List of cables used**

No.	Name	Length (m)	Shield	Backshell material	Remark
1	EIA-232 Cable	1.5	Y	Metal	-
2	DC Power Cable	1.9	N	Polyvinyl chloride	-
3	AC Power Cable	2.6	N	Polyvinyl chloride	-
4	RGB Cable	1.6	Y	Polyvinyl chloride	-
5	Printer Cable	1.9	Y	Polyvinyl chloride	-
6	DC Power Cable	1.8	N	Polyvinyl chloride	-
7	AC Power Cable	2.2	N	Polyvinyl chloride	-
8	Keyboard Cable	1.6	N	Polyvinyl chloride	-
9	AC Power Cable	2.0	N	Polyvinyl chloride	-
10	Mouse Cable	1.9	N	Polyvinyl chloride	-
11	10BASE-T Cable	5.0	N	Plastic	-
12	DC Power Cable	1.9	N	Polyvinyl chloride	-
13	AC Power Cable	1.8	N	Polyvinyl chloride	-
14	Modular Cable	2.0	N	Plastic	-
15	RS232C Cable	1.5	Y	Polyvinyl chloride	-

---

**A-pex International Co., Ltd.**

**YOKOWA LAB.**

108 Yokowa-cho, Ise-shi, Mie-ken 516-1106 JAPAN

Telephone: int +81 596 39 1485

Facsimile: int +81 596 39 0232

### 3 SYSTEM TEST CONFIGURATION

#### 3.1 Justification

The system was configured in typical fashion (as a customer would normally use it) for testing.

Test mode : Transmitting mode

Performed the test about channels 1(low:2402MHz), 40(mid:2441MHz) and 79(high:2480MHz) among 79 channels of all Carrier frequencies.

#### 3.2 Configuration of Tested System

Figure 4.1 Configuration of Tested System

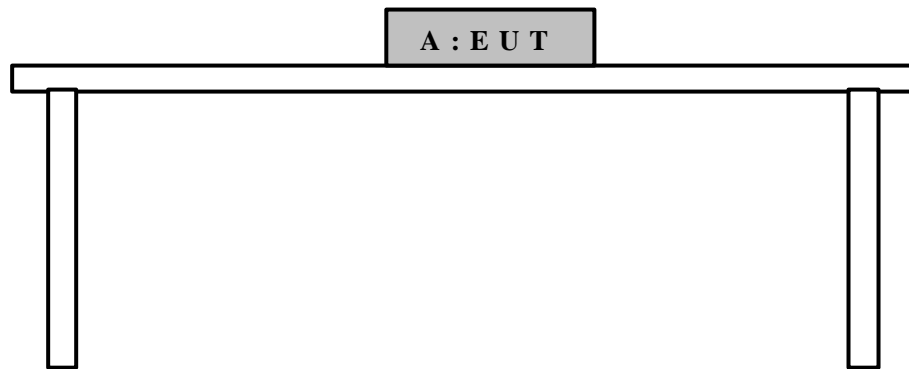
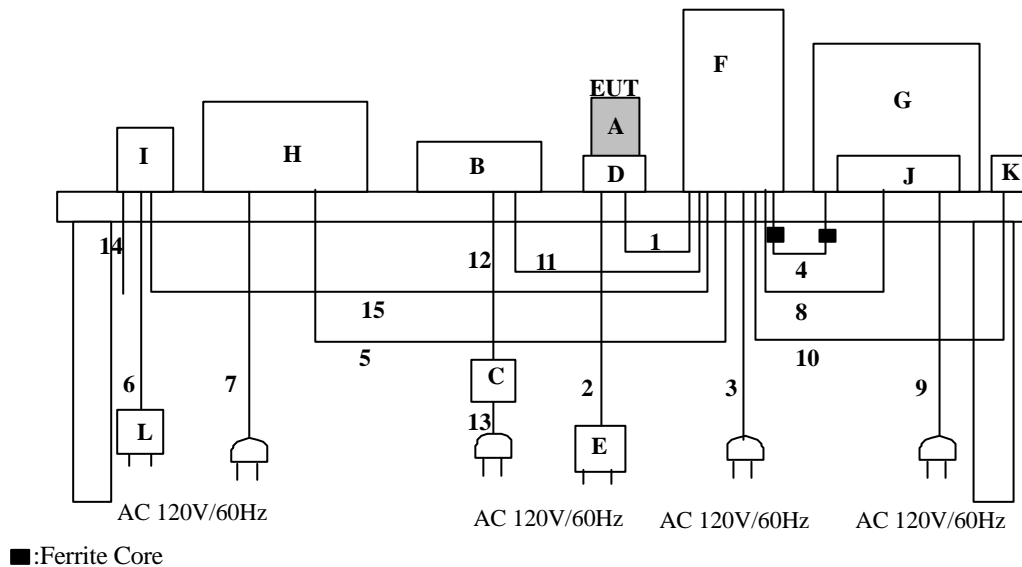

Figure 4.2 Configuration of Tested System (Only Conducted emission: AC Lines)



## 4 Measurement Uncertainty

### Conducted Emission Test

The measurement uncertainty (with a 95% confidence level) for this test was  $\pm 2.0$ dB.

The data listed in this test report has enough margin, more than 2.0dB.

### Radiated Emission Test

The measurement uncertainty (with a 95% confidence level) for this test using Biconical antenna is  $\pm 4.4$ dB.

The measurement uncertainty (with a 95% confidence level) for this test using Logperiodic antenna is  $\pm 4.8$ dB.

The measurement uncertainty (with a 95% confidence level) for this test using Horn antenna is  $\pm 5.8$ dB.

The data listed in this test report may exceed the test limit because it does not have enough margin.

---

**A-pex International Co., Ltd.**

**YOKOWA LAB.**

108 Yokowa-cho, Ise-shi, Mie-ken 516-1106 JAPAN

Telephone: int +81 596 39 1485

Facsimile: int +81 596 39 0232



**Test report****FCC ID** : PZWBHT-100F**Our reference** : 22DE0036-YW-2**Page** : 9 of 18**Issued date** : January 10, 2002

## 5 TEST EQUIPMENT USED

<u>Name</u>	<u>Manufacturer</u>	<u>Model</u>	<u>Control No.</u>	<u>Calibrated Until</u>
Pre Amplifier	Hewlett Packard	8447D	AF-01	March 30, 2002
Pre Amplifier	Hewlett Packard	8449B	AF-04	November 3, 2002
Biconical Antenna	Schwarzbeck	BBA9106	BA-03	April 30, 2002
Logperiodic Antenna	Schwarzbeck	UKLP9140-A	LA-06	April 30, 2002
LISN	Schwarzbeck	NSLK8127	LS-03	November 5, 2002
LISN	Rohde & Schwarz	ESH3-Z5	LS-04	November 5, 2002
Horn Antenna	AH System, Inc	SAS-200/571	HA-01	May 19, 2002
Horn Antenna	Schwarzbeck	BBHA9170	HA-03	November 22, 2002
High Pass Filter	Tokimec	TF323DCA	HF-04	October 14, 2002
Spectrum Analyzer	Hewlett packard	8567A	SA-04	March 30, 2002
Spectrum Analyzer	Advantest	R3271	SA-05	January 31, 2002
Test Receiver	Rohde & Schwarz	ESVS30	TR-02	April 11, 2002
Test Receiver	Rohde & Schwarz	ESHS10	TR-05	August 23, 2002
Power Sensor	Hewlett packard	ECP-E18A	PS-01	May 28, 2002
Power Meter	Hewlett packard	EPM-442A	PM-01	May 28, 2002

All measurement equipment is traceable to national standards.

---

**A-pex International Co., Ltd.**

**YOKOWA LAB.**

108 Yokowa-cho, Ise-shi, Mie-ken 516-1106 JAPAN

Telephone: int +81 596 39 1485

Facsimile: int +81 596 39 0232

## 6 SUMMARY OF TESTS

### 6.1 §15.207 Conducted Emissions

#### **Test Procedure**

EUT was placed on a platform of nominal size, 1m by 1.5m, raised 80cm above the conducting ground plane. The rear of tabletop was located 40cm to the vertical conducting plane. The rear of EUT, including peripherals aligned and flush with rear of tabletop. All other surfaces of tabletop was at least 80cm from any other grounded conducting surface. I/O cables and AC cables that were connected to the peripherals were bundled in center. They were folded back and forth forming a bundle 30cm to 40cm long and were hanged at a 40cm height to the ground plane. Each EUT current-carrying power lead, except the ground (safety) lead, were individually connected through a LISN to the input power source. All unused 50ohm connectors of the LISN were resistively terminated in 50ohm when not connected to the measuring equipment.

The AC Mains Terminal Continuous disturbance Voltage has been measured with the EUT on a shielded room. The EUT was connected to a Line Impedance Stabilization Network (LISN).

An overview sweep with peak detection has been performed.

The measurements have been performed with a CISPR quasi-peak detector (IF BW 10kHz) .  
(Measurement range : 450kHz to 30MHz)

**Test data** : APPENDIX A1 to A3 (BHT-100BF)  
: APPENDIX A4 to A6 (BHT-100QF)  
**Photographs of test setup** : Page 14(BHT-100BF) and Page 15(BHT-100QF)  
**Test result** : Pass  
**Test instruments** : LS-03, LS-04, SA-04, TR-05

### 6.2 §15.247(a)(1) Frequency Hopping Systems

Wireless Module (Model No. PROXIM RangeLAN2 633002CE-US) uses 79 channels, each 1MHz wide. The system hops over one of 15 pseudorandom sequences. On average, each channel is used equally.

---

**A-pex International Co., Ltd.**  
**YOKOWA LAB.**

108 Yokowa-cho, Ise-shi, Mie-ken 516-1106 JAPAN

Telephone: int +81 596 39 1485

Facsimile: int +81 596 39 0232

### **6.3 §15.247(a)(1)(ii) Channel Utilization**

The total number of channels is 79

**Test data** : APPENDIX A7(BHT-100BF)  
: APPENDIX A8(BHT-100QF)  
**Test result** : Pass

20dB band width

#### **BHT-100BF**

1. 2402MHz(Low) : 0.9960MHz < 1MHz
2. 2441MHz(Mid) : 0.9880MHz < 1MHz
3. 2480MHz(High) : 0.9800MHz < 1MHz

**Test data** : APPENDIX A9 (BHT-100BF)  
**Photographs of test setup** : Page16  
**Test result** : Pass

#### **BHT-100QF**

1. 2402MHz(Low) : 0.9900MHz < 1MHz
2. 2441MHz(Mid) : 0.9780MHz < 1MHz
3. 2480MHz(High) : 0.9680MHz < 1MHz

**Test data** : APPENDIX A10 (BHT-100QF)  
**Photographs of test setup** : Page17  
**Test result** : Pass

Dwell time shows worst case transmission time in a given slot : 18ms. Elapsed time < 100% duty  
Maximum allowed 400ms

**Test data** : APPENDIX A11  
**Test result** : Pass

**Test instruments** : SA-05, HA-01, AF-04

#### **6.4 § 15.247(b) Maximum Peak Out Put Power(Radiated)**

##### **Test Procedure**

EUT was placed on a platform of nominal size, 1m by 1.5m, raised 80cm above the conducting ground plane. I/O cables that were connected to the peripherals were bundled in center. They were folded back and forth forming a bundle 30cm to 40cm long and were hanged 40cm height to the ground plane. Test was made with the antenna positioned in both the horizontal and vertical planes of polarization. The measurement antenna was varied in height above the conducting ground plane to obtain the maximum signal strength.

The Radiated Electric Field Strength intensity has been measured on an open test site with a ground plane and at a distance of 3m.

The measuring antenna height was varied between 1 to 4m and EUT was rotated a full revolution in order to obtain the maximum value of the electric field intensity.

The measurements were performed for both vertical and horizontal antenna polarization.

For the EUT, turn table was rotated against to three orthogonal axes then receive antenna was move up and down in order to find maximum emission point.

The point which is indicated in attached photograph(Page 16 and 17) was found as maximum emission point.

**Test data** : APPENDIX A12 to A18 (BHT-100BF)  
: APPENDIX A19 to A25 (BHT-100QF)  
**Photographs of test setup** : Page16(BHT-100BF) and Page17(BHT-100QF)  
**Test result** : Pass  
  
**Test instruments** : SA-05, HA-01, AF-04

#### **6.5 § 15.247(b) Maximum Peak Out Put Power(Conducted)**

##### **Test Procedure**

The Maximum Peak Output power was measured with a power meter connected to the antenna port.

\* Antenna Gain dose not exceed 6dBi.

**Test data** : APPENDIX A26 (BHT-100BF)  
: APPENDIX A27 (BHT-100QF)  
**Test result** : Pass  
**Test instruments** : PS-01, PM-01, SA-05

---

**A-pex International Co., Ltd.**

**YOKOWA LAB.**

108 Yokowa-cho, Ise-shi, Mie-ken 516-1106 JAPAN

Telephone: int +81 596 39 1485

Facsimile: int +81 596 39 0232

## **6.6 § 15.247(c) Out of Band Emissions(Radiated)**

### **Test Procedure**

EUT was placed on a platform of nominal size, 1m by 1.5m, raised 80cm above the conducting ground plane. I/O cables that were connected to the peripherals were bundled in center. They were folded back and forth forming a bundle 30cm to 40cm long and were hanged 40cm height to the ground plane. Test was made with the antenna positioned in both the horizontal and vertical planes of polarization. The measurement antenna was varied in height above the conducting ground plane to obtain the maximum signal strength.

The Radiated Electric Field Strength intensity has been measured on an open test site with a ground plane and at a distance of 1m and 3m.

\*Test distance 3m : 30MHz to 10GHz / 1m : 10GHz to 26GHz

The measuring antenna height was varied between 1 to 4m and EUT was rotated a full revolution in order to obtain the maximum value of the electric field intensity.

The measurements were performed for both vertical and horizontal antenna polarization.

For the EUT, turn table was rotated against to three orthogonal axes then receive antenna was move up and down in order to find maximum emission point.

The point which is indicated in attached photograph(Page 16 and 17) was found as maximum emission point.

### **Radiated Spurious emissions**

In any 100kHz bandwidth outside the frequency band in which the spread spectrum intentional radiator is operating, the radio frequency power that is produced by the intentional radiator confirmed 20dB below that in the 100kHz bandwidth within the band that contains the highest level of the desired power, based on a radiated measurement. The result was also satisfied the general limits specified in Sec.15.209(a).

Measurement range : 30MHz to 1000MHz CISPR QP Detector, IF BW 120kHz

: 1GHz to 26GHz PK(RBW 1MHz, VBW 1MHz) and AV(RBW 1MHz, VBW 10Hz) Detector

**Test data** : APPENDIX A28 to A30: 30 –1000MHz (BHT-100BF)  
: APPENDIX A31 to A33: 1 – 26GHz (BHT-100BF)  
: APPENDIX A34 to A36: 30 –1000MHz (BHT-100QF)  
: APPENDIX A37 to A39: 1 – 26GHz (BHT-100QF)  
**Photographs of test setup** : Page16(BHT-100BF) and Page 17(BHT-100QF)  
**Test result** : Pass  
**Test instruments** : AF-01, AF-04, BA-03, LA-06, HA-01, HA-03, HF-04, SA-04, SA-05, TR-02

## **6.7 § 15.247(c) Out of Band Emissions(Conducted)**

### **Test Procedure**

The Out of Band Emissions(Conducted) was measured with a spectrum analyzer connected to the antenna port.

**Test data** : APPENDIX A40 to A51 (BHT-100BF)  
: APPENDIX A52 to A63 (BHT-100QF)  
**Test result** : Pass  
**Test instruments** : SA-05

---

**A-pex International Co., Ltd.**

**YOKOWA LAB.**

108 Yokowa-cho, Ise-shi, Mie-ken 516-1106 JAPAN

Telephone: int +81 596 39 1485

Facsimile: int +81 596 39 0232

**Photographs of test setup(1)**

**BHT-100BF**

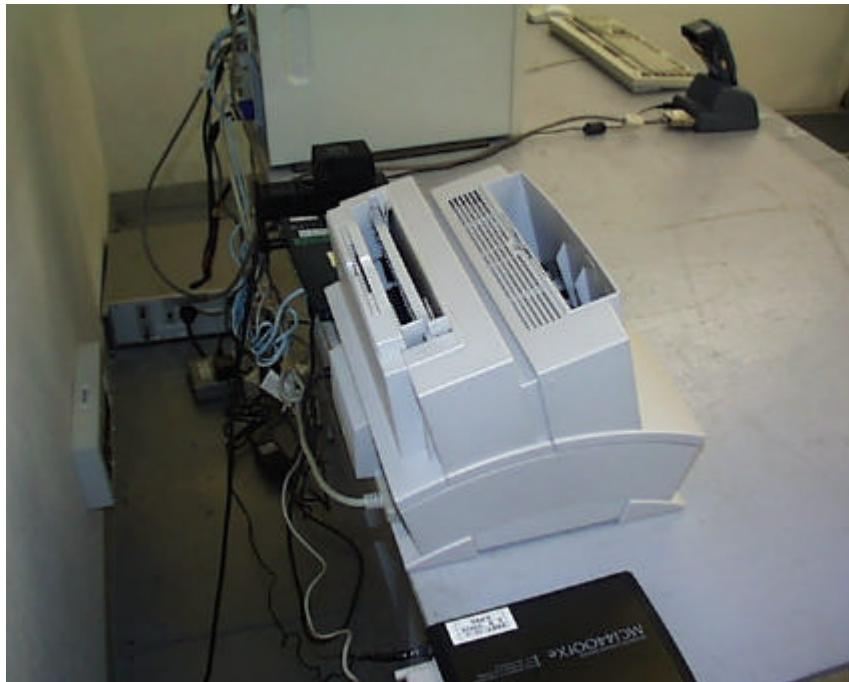

---

**A-pex International Co., Ltd.**  
**YOKOWA LAB.**

108 Yokowa-cho, Ise-shi, Mie-ken 516-1106 JAPAN

Telephone: int +81 596 39 1485

Facsimile: int +81 596 39 0232

**Photographs of test setup(2)**

BHT-100QF

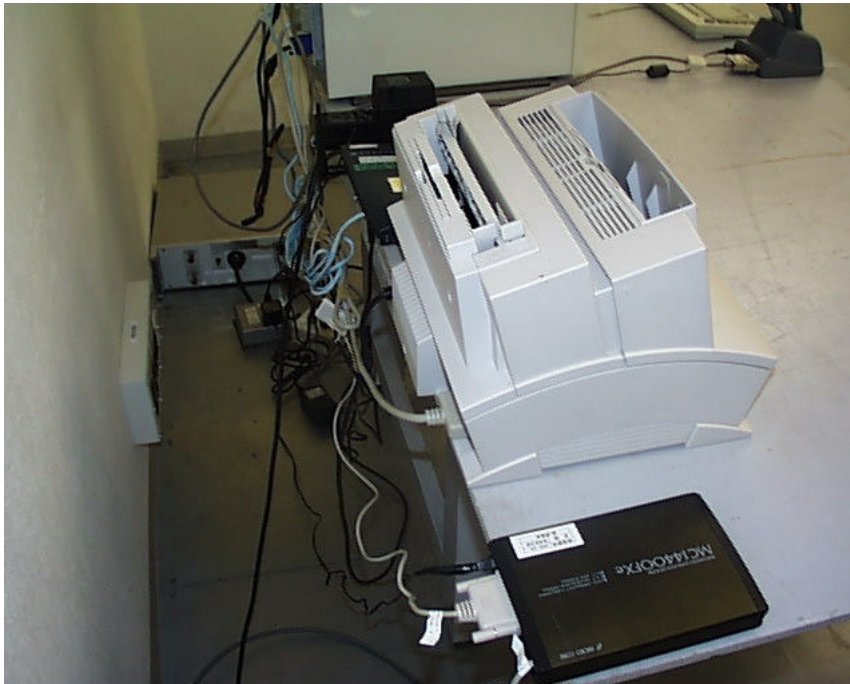

---

**A-pex International Co., Ltd.**  
**YOKOWA LAB.**

108 Yokowa-cho, Ise-shi, Mie-ken 516-1106 JAPAN

Telephone: int +81 596 39 1485

Facsimile: int +81 596 39 0232

**Photographs of test setup(3)**

**BHT-100BF**



---

**A-pex International Co., Ltd.**  
**YOKOWA LAB.**

108 Yokowa-cho, Ise-shi, Mie-ken 516-1106 JAPAN

Telephone: int +81 596 39 1485

Facsimile: int +81 596 39 0232



**Photographs of test setup(4)**

BHT-100QF

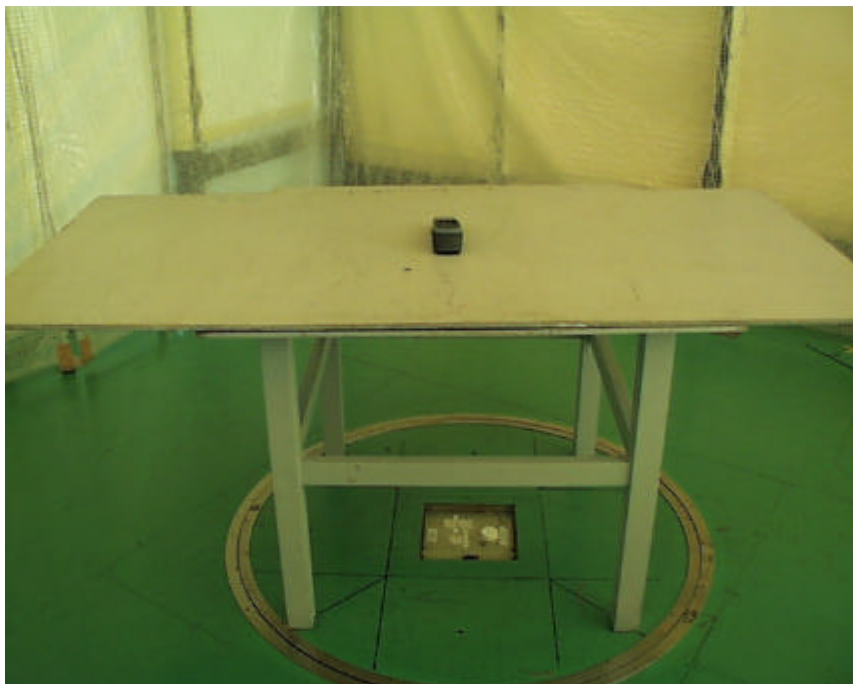

---

**A-pex International Co., Ltd.**  
**YOKOWA LAB.**

108 Yokowa-cho, Ise-shi, Mie-ken 516-1106 JAPAN

Telephone: int +81 596 39 1485

Facsimile: int +81 596 39 0232

## **APPENDIX**

### **Test Data**

1	§15.207 Conducted Emissions	<u>A 1 to A 6</u>
2	§15.247(a)(1)(ii) Channel Utilization	<u>A 7 to A11</u>
3	§15.247(b) Maximum Peak Out Put Power(Radiated)	<u>A12 to A25</u>
4	§15.247(b) Maximum Peak Out Put Power(Conducted)	<u>A26 to A27</u>
5	§15.247(c) Out of Band Emissions(Radiated)	<u>A28 to A39</u>
6	§15.247(c) Out of Band Emissions(Conducted)	<u>A40 to A63</u>

---

**A-pex International Co., Ltd.**

**YOKOWA LAB.**

108 Yokowa-cho, Ise-shi, Mie-ken 516-1106 JAPAN

Telephone: int +81 596 39 1485

Facsimile: int +81 596 39 0232