

FCC Radio Test Report

FCC ID: PZ3-SSB

This report concerns (check one): Original Grant Class I Change Class II Change

Project No. : 1312128A
Equipment : Primex Wireless Smart Sync Bridge
Test Model : BC100-E
Series Model : BC100
Applicant : Primex Wireless, Inc.
Address : 965 Wells Street Lake Geneva, WI 53147 United States

Date of Receipt : Jan. 05, 2017
Date of Test : Jan. 05, 2017 ~ Jan. 25, 2017
Issued Date : Jan. 26, 2017
Tested by : BTL Inc.

Testing Engineer : Rush Kao
(Rush Kao)

Technical Manager : Jeff Yang
(Jeff Yang)

Authorized Signatory : Andy Chiu
(Andy Chiu)

B T L I N C .

B1, No. 37, Lane 365, Yang-Guang St.,
Nei-Hu District, Taipei City 114, Taiwan.
TEL: +886-2-2657-3299 FAX: +886-2-2657-3331

Declaration

BTL represents to the client that testing is done in accordance with standard procedures as applicable and that test instruments used has been calibrated with standards traceable to international standard(s) and/or national standard(s).

BTL's reports apply only to the specific samples tested under conditions. It is manufacture's responsibility to ensure that additional production units of this model are manufactured with the identical electrical and mechanical components. **BTL** shall have no liability for any declarations, inferences or generalizations drawn by the client or others from **BTL** issued reports.

BTL's report must not be used by the client to claim product certification, approval, or endorsement by NVLAP, NIST, or any agency of the Federal Government.

This report is the confidential property of the client. As a mutual protection to the clients, the public and **BTL-self**, extracts from the test report shall not be reproduced except in full with **BTL's** authorized written approval.

BTL's laboratory quality assurance procedures are in compliance with the **ISO Guide 17025** requirements, and accredited by the conformity assessment authorities listed in this test report.

Limitation

For the use of the authority's logo is limited unless the Test Standard(s)/Scope(s)/Item(s) mentioned in this test report is (are) included in the conformity assessment authorities acceptance respective.

Table of Contents	Page
1 . CERTIFICATION	6
2 . SUMMARY OF TEST RESULTS	7
2.1 TEST FACILITY	8
2.2 MEASUREMENT UNCERTAINTY	8
3 . GENERAL INFORMATION	10
3.1 GENERAL DESCRIPTION OF EUT	10
3.2 DESCRIPTION OF TEST MODES	11
3.3 TABLE OF PARAMETERS OF TEXT SOFTWARE SETTING	12
3.4 BLOCK DIAGRAM SHOWING THE CONFIGURATION OF SYSTEM TESTED	13
3.5 DESCRIPTION OF SUPPORT UNITS	13
4 . EMC EMISSION TEST	14
4.1 CONDUCTED EMISSION MEASUREMENT	14
4.1.1 POWER LINE CONDUCTED EMISSION LIMITS	14
4.1.2 TEST PROCEDURE	14
4.1.3 DEVIATION FROM TEST STANDARD	14
4.1.4 TEST SETUP	15
4.1.5 EUT OPERATING CONDITIONS	15
4.1.6 EUT TEST CONDITIONS	15
4.1.7 TEST RESULTS	15
4.2 RADIATED EMISSION MEASUREMENT	16
4.2.1 RADIATED EMISSION LIMITS	16
4.2.2 TEST PROCEDURE	17
4.2.3 DEVIATION FROM TEST STANDARD	17
4.2.4 TEST SETUP	18
4.2.5 EUT OPERATING CONDITIONS	19
4.2.6 EUT TEST CONDITIONS	19
4.2.7 TEST RESULTS (9KHZ TO 30MHZ)	19
4.2.7 TEST RESULTS (30MHZ TO 1000 MHZ)	19
4.2.7 TEST RESULTS (ABOVE 1000 MHZ)	19
5 . BANDWIDTH TEST	20
5.1 APPLIED PROCEDURES	20
5.1.1 TEST PROCEDURE	20
5.1.2 DEVIATION FROM STANDARD	20
5.1.3 TEST SETUP	20
5.1.4 EUT OPERATION CONDITIONS	20
5.1.5 EUT TEST CONDITIONS	20
5.1.6 TEST RESULTS	20
6 . MAXIMUM PEAK CONDUCTED OUTPUT POWER TEST	21

Table of Contents	Page
6.1 APPLIED PROCEDURES / LIMIT	21
6.1.1 TEST PROCEDURE	21
6.1.2 DEVIATION FROM STANDARD	21
6.1.3 TEST SETUP	21
6.1.4 EUT OPERATION CONDITIONS	21
6.1.5 EUT TEST CONDITIONS	21
6.1.6 TEST RESULTS	21
7 . ANTENNA CONDUCTED SPURIOUS EMISSION	22
7.1 APPLIED PROCEDURES / LIMIT	22
7.1.1 TEST PROCEDURE	22
7.1.2 DEVIATION FROM STANDARD	22
7.1.3 TEST SETUP	22
7.1.4 EUT OPERATION CONDITIONS	22
7.1.5 EUT TEST CONDITIONS	22
7.1.6 TEST RESULTS	22
8 . POWER SPECTRAL DENSITY TEST	23
8.1 APPLIED PROCEDURES / LIMIT	23
8.1.1 TEST PROCEDURE	23
8.1.2 DEVIATION FROM STANDARD	23
8.1.3 TEST SETUP	23
8.1.4 EUT OPERATION CONDITIONS	23
8.1.5 EUT TEST CONDITIONS	23
8.1.6 TEST RESULTS	23
9 . MEASUREMENT INSTRUMENTS LIST	24
10 . EUT TEST PHOTO	26
ATTACHMENT A - CONDUCTED EMISSION	35
ATTACHMENT B - RADIATED EMISSION (9KHZ TO 30MHZ)	40
ATTACHMENT C - RADIATED EMISSION (30MHZ TO 1000MHZ)	53
ATTACHMENT D - RADIATED EMISSION (ABOVE 1000MHZ)	60
ATTACHMENT E - BANDWIDTH	99
ATTACHMENT F – MAXIMUM PEAK CONDUCTED OUTPUT POWER	106
ATTACHMENT G - ANTENNA CONDUCTED SPURIOUS EMISSION	108
ATTACHMENT H - POWER SPECTRAL DENSITY	128

REPORT ISSUED HISTORY

Issued No.	Description	Issued Date
BTL-FCCP-2-1312128A	Original Issue.	Jan. 26, 2017

1. CERTIFICATION

Equipment : Primex Wireless Smart Sync Bridge
Brand Name : Primex
Test Model : BC100-E
Series Model : BC100
Applicant : Primex Wireless, Inc.
Manufacturer : Top Union Electronics Corp.
Address : No. 480, Nioupu E.Rd.,Hsinchu,Taiwan.
Factory : Top Union Electronics Corp.
Address : No. 480, Nioupu E.Rd.,Hsinchu,Taiwan.
Date of Test : Jan. 05, 2017 ~ Jan. 25, 2017
Test Sample : Engineering Sample
Standard(s) : FCC Part15, Subpart C:(15.247)
ANSI C63.10-2013

The above equipment has been tested and found compliance with the requirement of the relative standards by BTL Inc.

The test data, data evaluation, and equipment configuration contained in our test report (Ref No. BTL-FCCP-2-1312128A) were obtained utilizing the test procedures, test instruments, test sites that has been accredited by the Authority of TAF according to the ISO-17025 quality assessment standard and technical standard(s).

2. SUMMARY OF TEST RESULTS

Test procedures according to the technical standard(s):

Applied Standard(s): FCC Part15 (15.247) , Subpart C				
Standard(s)	Section	Test Item	Judgment	Remark
	15.207	Conducted Emission	PASS	
	15.247(d)	Antenna conducted Spurious Emission	PASS	
	15.247(a)(2)	6dB Bandwidth	PASS	
	15.247(b)(3)	Peak Output Power	PASS	
	15.247(e)	Power Spectral Density	PASS	
	15.203	Antenna Requirement	PASS	
	15.247(d)/ 15.205/ 15.209	Transmitter Radiated Emissions	PASS	

NOTE:

(1) "N/A" denotes test is not applicable in this test report.

2.1 TEST FACILITY

The test facilities used to collect the test data in this report:

Conducted emission Test:

C05: (VCCI RN: C-4742; FCC RN:965108; FCC DN:TW1082)

No. 68-1, Ln. 169, Sec.2, Datong Rd., Xizhi Dist., New Taipei City 221, Taiwan

Radiated emission Test (Below 1 GHz):

CB15: (FCC RN:674415; FCC DN:TW0659)

No. 68-1, Ln. 169, Sec.2, Datong Rd., Xizhi Dist., New Taipei City 221, Taiwan

Radiated emission Test (Above 1 GHz):

CB15: (FCC RN:674415; FCC DN:TW0659)

No. 68-1, Ln. 169, Sec.2, Datong Rd., Xizhi Dist., New Taipei City 221, Taiwan

2.2 MEASUREMENT UNCERTAINTY

Where relevant, the following measurement uncertainty levels have been estimated for tests performed on the EUT as specified in CISPR 16-4-2. The BTL measurement uncertainty is less than the CISPR 16-4-2 U_{CISPR} requirement.

The reported uncertainty of measurement $y \pm U$, where expanded uncertainty U is based on a standard uncertainty multiplied by a coverage factor of $k=2$, providing a level of confidence of approximately 95 %.

A. Conducted emission test:

Test Site	Method	Measurement Frequency Range	U,(dB)
C05	CISPR	150 kHz ~ 30MHz	3.06

B. Radiated emission test:

Test Site	Method	Measurement Frequency Range	U,(dB)
CB15 (3m)	CISPR	9kHz ~ 150kHz	2.96
		150kHz ~ 30MHz	2.74

Test Site	Method	Measurement Frequency Range	Ant.	U,(dB)
CB15 (3m)	CISPR	30MHz ~ 200MHz	V	4.76
		30MHz ~ 200MHz	H	4.28
		200MHz ~ 1,000MHz	V	5.08
		200MHz ~ 1,000MHz	H	4.50

Test Site	Method	Measurement Frequency Range	Ant.	U,(dB)
CB15 (3m)	CISPR	1GHz ~ 6GHz	V	4.48
		1GHz ~ 6GHz	H	4.50
		6GHz ~ 18GHz	V	4.30
		6GHz ~ 18GHz	H	4.14

Test Site	Method	Measurement Frequency Range	U,(dB)
CB15 (1m)	CISPR	18 ~ 26.5 GHz	4.72
		26.5 ~ 40 GHz	5.20

Our calculated Measurement Instrumentation Uncertainty is shown in the tables above. These are our U_{lab} values in CISPR 16-4-2 terminology.

Since Table 1 of CISPR 16-4-2 has values of measurement instrumentation uncertainty, called U_{CISPR} , as follows:

Conducted Disturbance (mains port) – 150 kHz – 30 MHz: 3.6 dB

Radiated Disturbance (electric field strength on an open area test site or alternative test site) – 30 MHz – 1000 MHz: 5.2 dB

It can be seen that our U_{lab} values are smaller than U_{CISPR} .

Note: unless specifically mentioned, the uncertainty of measurement has not been taken into account to declare the compliance or non-compliance to the specification.

3. GENERAL INFORMATION

3.1 GENERAL DESCRIPTION OF EUT

Equipment	Primex Wireless Smart Sync Bridge		
Brand Name	Primex		
Test Model	BC100-E		
Series Model	BC100		
Model Difference	Model Name		PoE
	P13770-WB, BC100 bridge POE		YES
	Q13770-WB, BC100 bridge		NO
Power Source	#1 DC voltage supplied from AC/DC adapter. PHIHONG / PSAA050A-050 #2 PoE supplied. #3 Battery supplied.		
Power Rating	#1 I/P: 100-240V~ 200mA 50-60Hz 13-20VA O/P: 5V--- 1A #2 44.0-57.0 V--- #3 3V--- (2 * AA Batteries)		
Product Description	Operation Frequency	2412~2462 MHz	
	Modulation Technology	802.11b:DSSS 802.11g:OFDM 802.11n:OFDM	
	Bit Rate of Transmitter	802.11b: 11/5.5/2/1 Mbps 802.11g: 54/48/36/24/18/12/9/6 Mbps 802.11n up to 65 Mbps	
	Output Power (Max.)	802.11b: 21.91 dBm 802.11g: 20.59 dBm 802.11n(20MHz): 20.49 dBm	

Note:

1. For a more detailed features description, please refer to the manufacturer's specifications or the user's manual.

2. Channel List:

CH01 – CH11 for 802.11b, 802.11g, 802.11n(20MHz)							
Channel	Frequency (MHz)	Channel	Frequency (MHz)	Channel	Frequency (MHz)	Channel	Frequency (MHz)
01	2412	04	2427	07	2442	10	2457
02	2417	05	2432	08	2447	11	2462
03	2422	06	2437	09	2452		

3. Table for Filed Antenna:

Ant.	Brand	Model Name	Antenna Type	Connector	Gain (dBi)
1	GainSpan	NA	Ceramic Chip	N/A	0

3.2 DESCRIPTION OF TEST MODES

To investigate the maximum EMI emission characteristics generates from EUT, the test system was pre-scanning tested base on the consideration of following EUT operation mode or test configuration mode which possible have effect on EMI emission level. Each of these EUT operation mode(s) or test configuration mode(s) mentioned above was evaluated respectively.

Pretest Mode	Description
Mode 1	TX B MODE CHANNEL 01/06/11
Mode 2	TX G MODE CHANNEL 01/06/11
Mode 3	TX N-20MHZ MODE CHANNEL 01/06/11
Mode 4	Normal Link

The EUT system operated these modes were found to be the worst case during the pre-scanning test as following:

For Conducted Test	
Final Test Mode	Description
Mode 4	Normal Link

For Radiated Test	
Final Test Mode	Description
Mode 1	TX B MODE CHANNEL 01/06/11
Mode 2	TX G MODE CHANNEL 01/06/11
Mode 3	TX N-20MHZ MODE CHANNEL 01/06/11

Note:

- (1) The measurements are performed at the high, middle, low available channels.
- (2) 802.11b mode: DBPSK (1Mbps)
 802.11g mode: OFDM (6Mbps)
 802.11n HT20 mode : BPSK (6.5Mbps)
 For radiated emission tests, the highest output powers were set for final test.
- (3) For radiated below 1G test, the 802.11b is found to be the worst case and recorded.
- (4) The EUT was programmed to be in continuously transmitting mode and the transmit duty cycle is not less than 98%.

3.3 TABLE OF PARAMETERS OF TEXT SOFTWARE SETTING

During testing, channel & power controlling software provided by the customer was used to control the operating channel as well as the output power level. The RF output power selection is for the setting of RF output power expected by the customer and is going to be fixed on the firmware of the final end product power parameters of WLAN

Test software version	Tera Term		
Frequency (MHz)	2412	2437	2462
802.11b	27	27	27
802.11g	27	27	27
802.11n (20MHz)	27	27	27

3.4 BLOCK DIAGRAM SHOWING THE CONFIGURATION OF SYSTEM TESTED

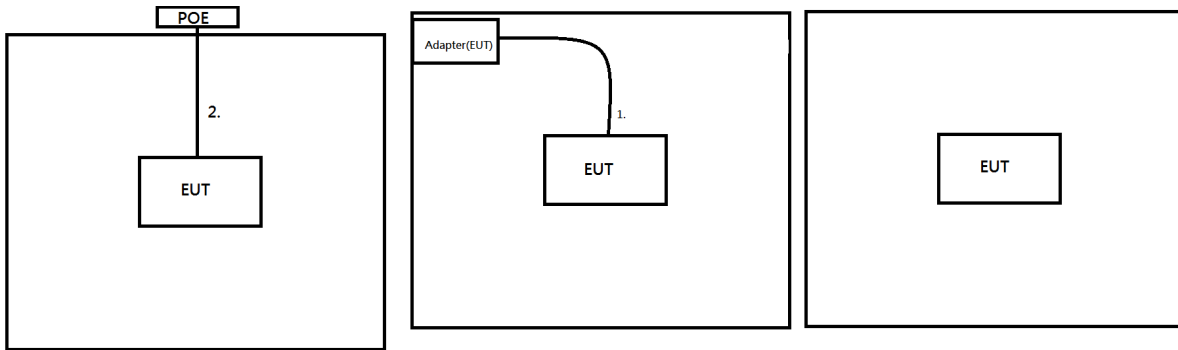

3.5 DESCRIPTION OF SUPPORT UNITS

The EUT has been tested as an independent unit together with other necessary accessories or support units. The following support units or accessories were used to form a representative test configuration during the tests.

Item	Equipment	Mfr/Brand	Model/Type No.	FCC ID	Series No.
-	-	-	-	-	-

Item	Shielded Type	Ferrite Core	Length	Note
1	NO	NO	10m	RJ45 cable
2	YES	NO	1.7m	Power cable

4. EMC EMISSION TEST

4.1 CONDUCTED EMISSION MEASUREMENT

4.1.1 POWER LINE CONDUCTED EMISSION LIMITS (Frequency Range 150KHz-30MHz)

Frequency of Emission (MHz)	Conducted Limit (dB μ V)	
	Quasi-peak	Average
0.15 -0.50	66 to 56*	56 to 46*
0.50 -5.0	56	46
5.0 -30.0	60	50

Note:

- (1) The limit of " * " decreases with the logarithm of the frequency
- (2) The test result calculated as following:
 Measurement Value = Reading Level + Correct Factor
 Correct Factor = Insertion Loss + Cable Loss + Attenuator Factor(if use)
 Margin Level = Measurement Value - Limit Value

The following table is the setting of the receiver

Receiver Parameters	Setting
Attenuation	10 dB
Start Frequency	0.15 MHz
Stop Frequency	30 MHz
IF Bandwidth	9 KHz

4.1.2 TEST PROCEDURE

- a. The EUT was placed 0.8 meters from the horizontal ground plane with EUT being connected to the power mains through a line impedance stabilization network (LISN). All other support equipments powered from additional LISN(s). The LISN provide 50 Ohm/ 50uH of coupling impedance for the measuring instrument.
- b. Interconnecting cables that hang closer than 40 cm to the ground plane shall be folded back and forth in the center forming a bundle 30 to 40 cm long.
- c. I/O cables that are not connected to a peripheral shall be bundled in the center. The end of the cable may be terminated, if required, using the correct terminating impedance. The overall length shall not exceed 1 m.
- d. LISN at least 80 cm from nearest part of EUT chassis.
- e. For the actual test configuration, please refer to the related Item –EUT Test Photos.

4.1.3 DEVIATION FROM TEST STANDARD

No deviation

4.1.4 TEST SETUP

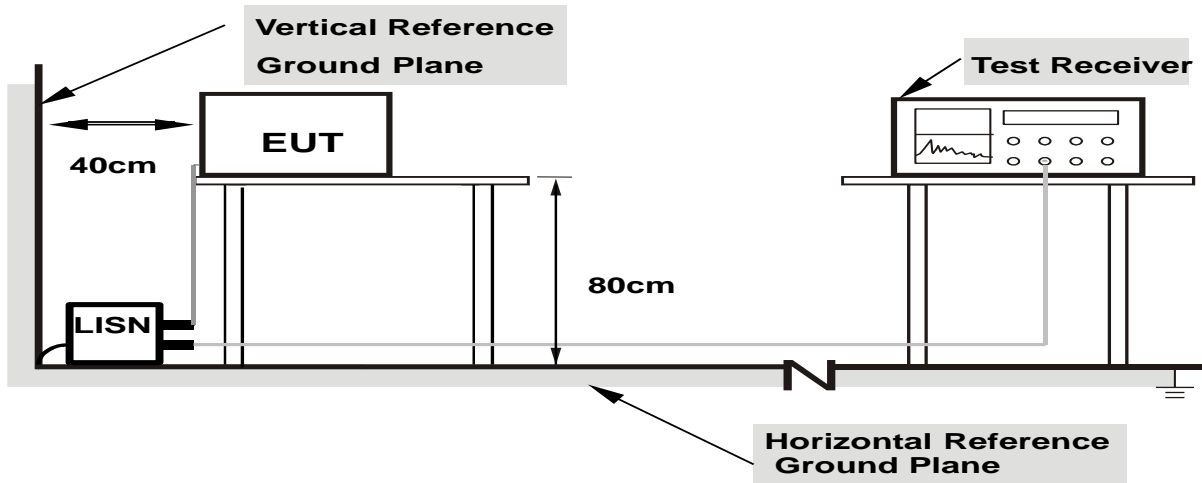

- Note:**
- 1. Support units were connected to second LISN.
 - 2. Both of LISNs (AMN) are 80 cm from EUT and at least 80 from other units and other metal planes

4.1.5 EUT OPERATING CONDITIONS

The EUT was placed on the test table and programmed in normal function.

4.1.6 EUT TEST CONDITIONS

Temperature: 25°C Relative Humidity: 55% Test Voltage: AC 120V/60Hz

4.1.7 TEST RESULTS

Please refer to the Attachment A.

4.2 RADIATED EMISSION MEASUREMENT

4.2.1 RADIATED EMISSION LIMITS

In case the emission fall within the restricted band specified on 15.205(a), then the 15.209(a) limit in the table below has to be followed.

LIMITS OF RADIATED EMISSION MEASUREMENT (9KHz-1000MHz)

Frequency (MHz)	Field Strength (microvolts/meter)	Measurement Distance (meters)
0.009~0.490	2400/F(KHz)	300
0.490~1.705	24000/F(KHz)	30
1.705~30.0	30	30
30~88	100	3
88~216	150	3
216~960	200	3
960~1000	500	3

LIMITS OF RADIATED EMISSION MEASUREMENT (Above 1000MHz)

Frequency (MHz)	(dBuV/m) (at 3 meters)	
	PEAK	AVERAGE
Above 1000	74	54

Notes:

- (1) The limit for radiated test was performed according to FCC PART 15C.
- (2) The tighter limit applies at the band edges.
- (3) Emission level (dBuV/m)=20log Emission level (uV/m).
- (4) The test result calculated as following:
 Measurement Value = Reading Level + Correct Factor
 Correct Factor = Antenna Factor + Cable Loss - Amplifier Gain(if use)
 Margin Level = Measurement Value - Limit Value

Spectrum Parameter	Setting
Attenuation	Auto
Start Frequency	1000 MHz
Stop Frequency	10th carrier harmonic
RBW / VBW (Emission in restricted band)	1MHz / 3MHz for Peak, 1MHz / 1/T for Average

Receiver Parameter	Setting
Attenuation	Auto
Start ~ Stop Frequency	9KHz~90KHz for PK/AVG detector
Start ~ Stop Frequency	90KHz~110KHz for QP detector
Start ~ Stop Frequency	110KHz~490KHz for PK/AVG detector
Start ~ Stop Frequency	490KHz~30MHz for QP detector
Start ~ Stop Frequency	30MHz~1000MHz for QP detector

4.2.2 TEST PROCEDURE

- a. The measuring distance of 3 m shall be used for measurements. The EUT was placed on the top of a rotating table 0.8 meter above the ground at a 3 meter semi-anechoic chamber. The table was rotated 360 degrees to determine the position of the highest radiation.(below 1GHz)
- b. The measuring distance of 3 m shall be used for measurements. The EUT was placed on the top of a rotating table 1.5 meter above the ground at a 3 meter semi-anechoic chamber. The table was rotated 360 degrees to determine the position of the highest radiation.(above 1GHz)
- c. The height of the equipment or of the substitution antenna shall be 0.8m or 1.5m; the height of the test antenna shall vary between 1 m to 4 m. Both horizontal and vertical polarizations of the antenna are set to make the measurement.
- d. For each suspected emission, the EUT was arranged to its worst case and then the antenna was tuned to heights find the maximum reading (used Bore sight function).
- e. The receiver system was set to peak and average detect function and specified bandwidth with maximum hold mode when the test frequency is above 1GHz.
- f. The initial step in collecting radiated emission data is a receiver peak detector mode pre-scanning the measurement frequency range. Significant peaks are then marked and then Quasi Peak detector mode re-measured.
- g. All readings are Peak unless otherwise stated QP in column of Note. Peak denotes that the Peak reading compliance with the QP Limits and then QP Mode measurement didn't perform. (below 1GHz)
- h. All readings are Peak Mode value unless otherwise stated AVG in column of Note. If the Peak Mode Measured value compliance with the Peak Limits and lower than AVG Limits, the EUT shall be deemed to meet both Peak & AVG Limits and then only Peak Mode was measured, but AVG Mode didn't perform. (above 1GHz)
- i. For the actual test configuration, please refer to the related Item –EUT Test Photos.

4.2.3 DEVIATION FROM TEST STANDARD

No deviation

4.2.4 TEST SETUP

(A) Radiated Emission Test Set-Up Frequency Below 1 GHz

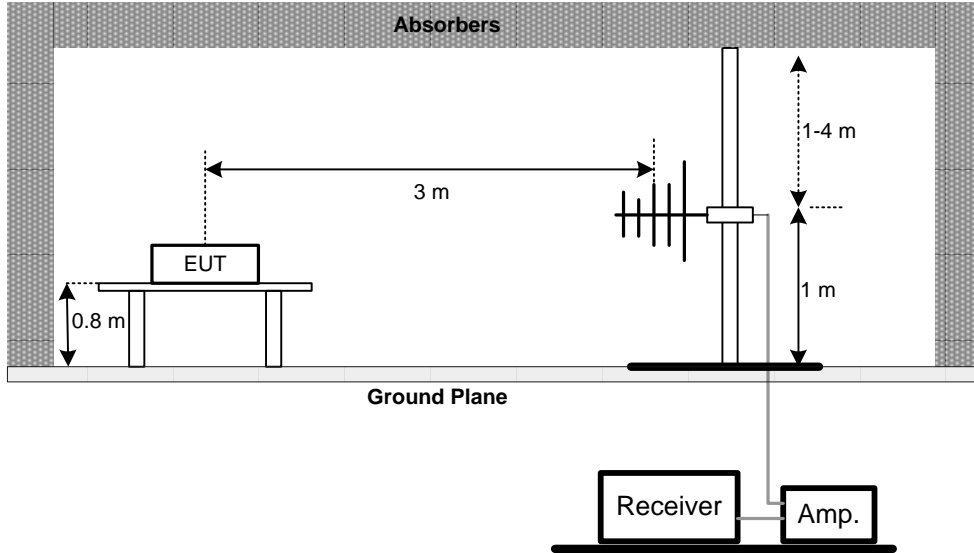

**(B) Radiated Emission Test Set-Up Frequency Above 1 GHz
Band edge**

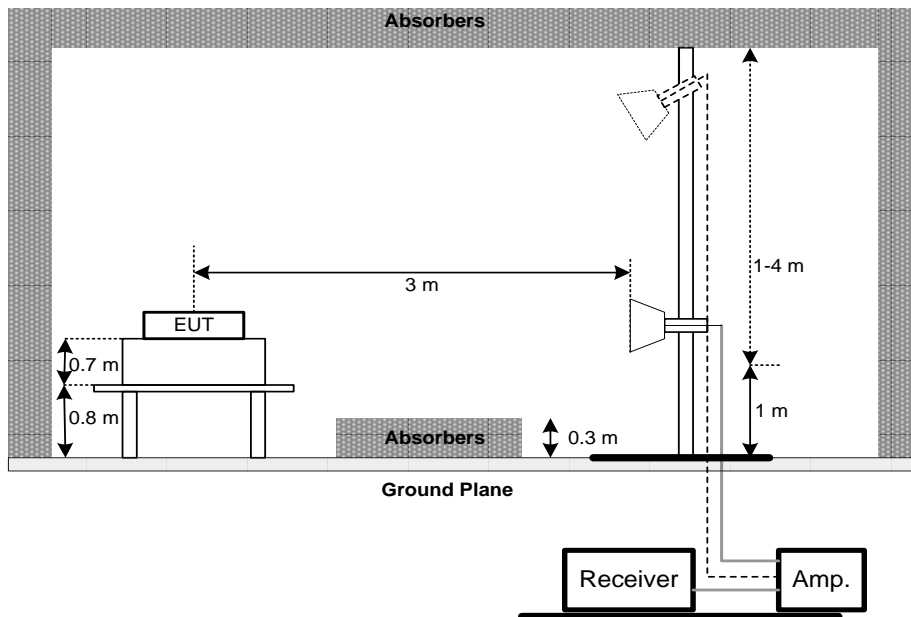

(C) For Radiated Emissions Below 30MHz

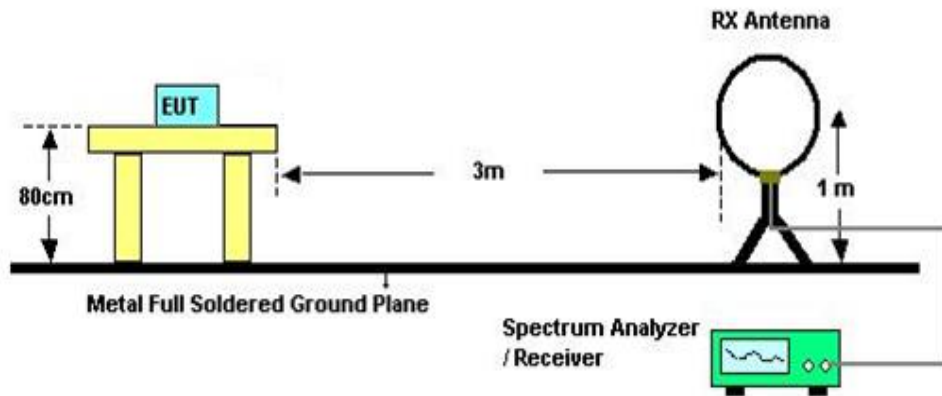

4.2.5 EUT OPERATING CONDITIONS

The EUT was programmed to be in continuously transmitting mode.

4.2.6 EUT TEST CONDITIONS

Temperature: 25°C Relative Humidity: 55% Test Voltage: AC 120V/60Hz

4.2.7 TEST RESULTS (9KHZ TO 30MHZ)

Please refer to the Attachment B

Remark:

- (1) The amplitude of spurious emissions which are attenuated by more than 20 dB below the permissible value has no need to be reported.
- (2) Distance extrapolation factor = $40 \log(\text{specific distance} / \text{test distance})$ (dB).
- (3) Limit line = specific limits (dBuV) + distance extrapolation factor.

4.2.7 TEST RESULTS (30MHZ TO 1000 MHZ)

Please refer to the Attachment C.

4.2.7 TEST RESULTS (ABOVE 1000 MHZ)

Please refer to the Attachment D.

Remark:

- (1) No limit: This is fundamental signal, the judgment is not applicable. For fundamental signal judgment was referred to Peak output test.

5. BANDWIDTH TEST

5.1 APPLIED PROCEDURES

FCC Part15 (15.247) , Subpart C			
Section	Test Item	Frequency Range (MHz)	Result
15.247(a)(2)	Bandwidth	2400-2483.5	PASS

5.1.1 TEST PROCEDURE

- a. The EUT was directly connected to the spectrum analyzer and antenna output port as show in the block diagram below,
- b. Spectrum Setting: RBW= 100KHz, VBW=300KHz, Sweep time = 2.5 ms.

5.1.2 DEVIATION FROM STANDARD

No deviation.

5.1.3 TEST SETUP

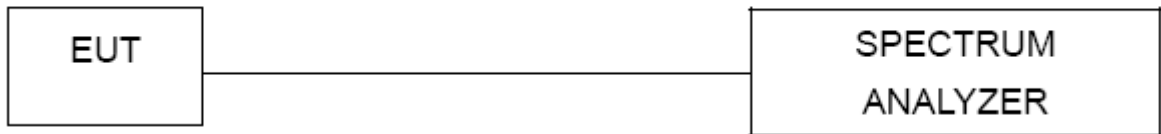

5.1.4 EUT OPERATION CONDITIONS

The EUT was programmed to be in continuously transmitting mode.

5.1.5 EUT TEST CONDITIONS

Temperature: 25°C Relative Humidity: 55% Test Voltage: AC 120V/60Hz

5.1.6 TEST RESULTS

Please refer to the Attachment E.

6. MAXIMUM PEAK CONDUCTED OUTPUT POWER TEST

6.1 APPLIED PROCEDURES / LIMIT

FCC Part15 (15.247) , Subpart C				
Section	Test Item	Limit	Frequency Range (MHz)	Result
15.247(b)(3)	Maximum Output Power	1 Watt or 30dBm	2400-2483.5	PASS

6.1.1 TEST PROCEDURE

- a. The EUT was directly connected to the power meter and antenna output port as show in the block diagram below,
- b. The maximum peak conducted output power was performed in accordance with method 9.1.2 of FCC KDB 558074 D01 DTS Meas Guidance.

6.1.2 DEVIATION FROM STANDARD

No deviation.

6.1.3 TEST SETUP



6.1.4 EUT OPERATION CONDITIONS

The EUT was programmed to be in continuously transmitting mode.

6.1.5 EUT TEST CONDITIONS

Temperature: 25°C Relative Humidity: 55% Test Voltage: AC 120V/60Hz

6.1.6 TEST RESULTS

Please refer to the Attachment F.

7. ANTENNA CONDUCTED SPURIOUS EMISSION

7.1 APPLIED PROCEDURES / LIMIT

In any 100 kHz bandwidth outside the frequency band in which the spread spectrum or digitally modulated device is operating, the RF power that is produced shall be at least 20 dB below that in the 100 kHz bandwidth within the band that contains the highest level of the desired power, based on either an RF conducted or a radiated measurement, provided that the transmitter demonstrates compliance with the peak conducted power limits.

7.1.1 TEST PROCEDURE

- a. The EUT was directly connected to the spectrum analyzer and antenna output port as show in the block diagram below,
- b. Spectrum Setting: RBW= 100KHz, VBW=300KHz, Sweep time = Auto.
- c. Offset=antenna gain+cable loss

7.1.2 DEVIATION FROM STANDARD

No deviation.

7.1.3 TEST SETUP



7.1.4 EUT OPERATION CONDITIONS

The EUT was programmed to be in continuously transmitting mode.

7.1.5 EUT TEST CONDITIONS

Temperature: 25°C Relative Humidity: 55% Test Voltage: AC 120V/60Hz

7.1.6 TEST RESULTS

Please refer to the Attachment G.

8. POWER SPECTRAL DENSITY TEST

8.1 APPLIED PROCEDURES / LIMIT

FCC Part15 (15.247) , Subpart C				
Section	Test Item	Limit	Frequency Range (MHz)	Result
15.247(e)	Power Spectral Density	8 dBm (in any 3KHz)	2400-2483.5	PASS

8.1.1 TEST PROCEDURE

- a. The EUT was directly connected to the spectrum analyzer and antenna output port as show in the block diagram below,
- b. Spectrum Setting: RBW=3KHz, VBW=10KHz, Sweep time = Auto.

8.1.2 DEVIATION FROM STANDARD

No deviation.

8.1.3 TEST SETUP



8.1.4 EUT OPERATION CONDITIONS

The EUT was programmed to be in continuously transmitting mode.

8.1.5 EUT TEST CONDITIONS

Temperature: 25°C Relative Humidity: 55% Test Voltage: AC 120V/60Hz

8.1.6 TEST RESULTS

Please refer to the Attachment H.

9. MEASUREMENT INSTRUMENTS LIST

Conducted Emission Measurement					
Item	Kind of Equipment	Manufacturer	Type No.	Serial No.	Calibrated until
1	TWO-LINE V-NETWORK	R&S	ENV216	101050	Jan. 24, 2018
2	Test Cable	TIMES	CFD300-NL	C05	Jun. 14, 2017
3	EMI Test Receiver	R&S	ESR7	101433	Dec. 08, 2017
4	Measurement Software	Farad	EZ EMC (Version NB-03A)	N/A	N/A

Radiated Emission Measurement					
Item	Kind of Equipment	Manufacturer	Type No.	Serial No.	Calibrated until
1	Preamplifier	EMCI	012645B	980267	Mar. 01, 2017
2	Preamplifier	EMCI	EMC02325	980217	Dec. 29, 2017
3	Test Cable	EMCI	EMC104-SM-S M-8000	8m	Jan. 04, 2018
4	Test Cable	EMCI	EMC104-SM-S M-800	150207	Jan. 04, 2018
5	Test Cable	EMCI	EEMC104-SM-S M-3000	151205	Jan. 04, 2018
6	MXE EMI Receiver	Agilent	N9038A	MY55420127	Jan. 09, 2018
7	Signal Analyzer	Agilent	N9010A	MY52220990	Feb. 23, 2017
8	Loop Ant	EMCO	6502	42960	Nov. 24, 2017
9	Horn Ant	SCHWARZBECK	BBHA 9120D	9120D-1342	Mar. 01, 2017
10	Trilog-Broadband Antenna	Schwarzbeck	VULB 9168	9168-548	Jan. 16, 2018
11	5dB Attenuator	EMCI	EMCI-N-6-05	AT-N0623	Jan. 16, 2018

6dB Bandwidth Measurement					
Item	Kind of Equipment	Manufacturer	Type No.	Serial No.	Calibrated until
1	Spectrum Analyzer	R&S	R&S/FSP30	100854	May 26, 2017

Peak Output Power Measurement					
Item	Kind of Equipment	Manufacturer	Type No.	Serial No.	Calibrated until
1	Power Meter	Anritsu	ML2495A	1128008	Aug. 17, 2017
2	Power Sensor	Anritsu	MA2411B	1126001	Aug. 17, 2017

Antenna Conducted Spurious Emission Measurement					
Item	Kind of Equipment	Manufacturer	Type No.	Serial No.	Calibrated until
1	Spectrum Analyzer	R&S	R&S/FSP30	100854	May 26, 2017

Power Spectral Density Measurement					
Item	Kind of Equipment	Manufacturer	Type No.	Serial No.	Calibrated until
1	Spectrum Analyzer	R&S	R&S/FSP30	100854	May 26, 2017

Remark: "N/A" denotes no model name, serial no. or calibration specified.
 All calibration period of equipment list is one year.

ATTACHMENT A - CONDUCTED EMISSION

Test Mode: Normal Lin1_Adapter

Line

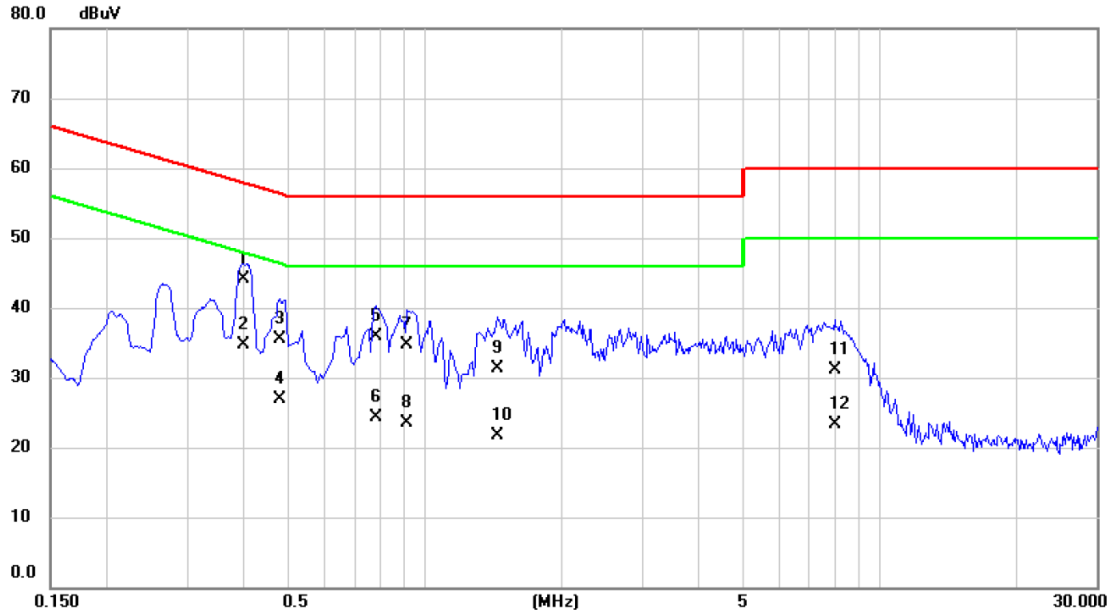

No.	Mk.	Freq. MHz	Reading Level dBuV	Correct Factor dB	Measure- ment dBuV	Limit dBuV	Margin dB	Detector	Comment
1		0.3992	34.50	9.66	44.16	57.87	-13.71	QP	
2	*	0.3992	25.00	9.66	34.66	47.87	-13.21	AVG	
3		0.4783	25.80	9.67	35.47	56.37	-20.90	QP	
4		0.4783	17.20	9.67	26.87	46.37	-19.50	AVG	
5		0.7790	26.20	9.67	35.87	56.00	-20.13	QP	
6		0.7790	14.70	9.67	24.37	46.00	-21.63	AVG	
7		0.9140	25.00	9.67	34.67	56.00	-21.33	QP	
8		0.9140	13.80	9.67	23.47	46.00	-22.53	AVG	
9		1.4450	21.70	9.69	31.39	56.00	-24.61	QP	
10		1.4450	12.10	9.69	21.79	46.00	-24.21	AVG	
11		7.9500	21.30	9.82	31.12	60.00	-28.88	QP	
12		7.9500	13.40	9.82	23.22	50.00	-26.78	AVG	

Test Mode: Normal Lin1_Adapter

Neutral

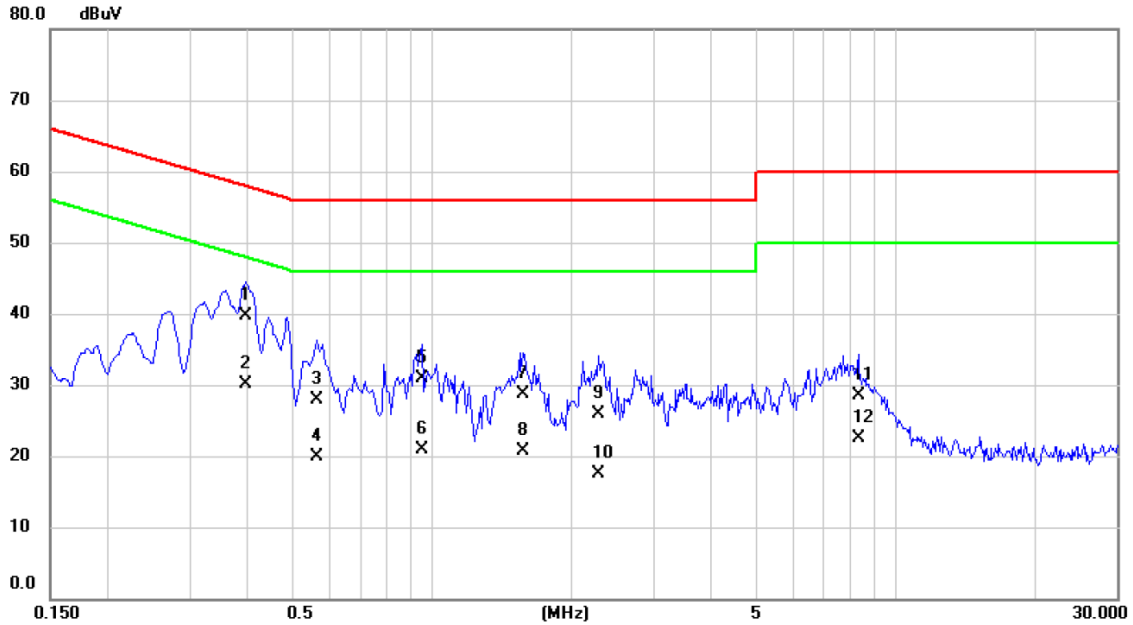

No.	Mk.	Freq. MHz	Reading Level dBuV	Correct Factor dB	Measure- ment dBuV	Limit dBuV	Margin dB	Detector	Comment
1		0.3964	30.00	9.66	39.66	57.93	-18.27	QP	
2	*	0.3964	20.40	9.66	30.06	47.93	-17.87	AVG	
3		0.5630	18.30	9.67	27.97	56.00	-28.03	QP	
4		0.5630	10.30	9.67	19.97	46.00	-26.03	AVG	
5		0.9500	21.30	9.68	30.98	56.00	-25.02	QP	
6		0.9500	11.30	9.68	20.98	46.00	-25.02	AVG	
7		1.5710	19.00	9.72	28.72	56.00	-27.28	QP	
8		1.5710	10.90	9.72	20.62	46.00	-25.38	AVG	
9		2.2910	16.10	9.75	25.85	56.00	-30.15	QP	
10		2.2910	7.80	9.75	17.55	46.00	-28.45	AVG	
11		8.3000	18.70	9.83	28.53	60.00	-31.47	QP	
12		8.3000	12.70	9.83	22.53	50.00	-27.47	AVG	

Test Mode: Normal LinI_PoE

Line

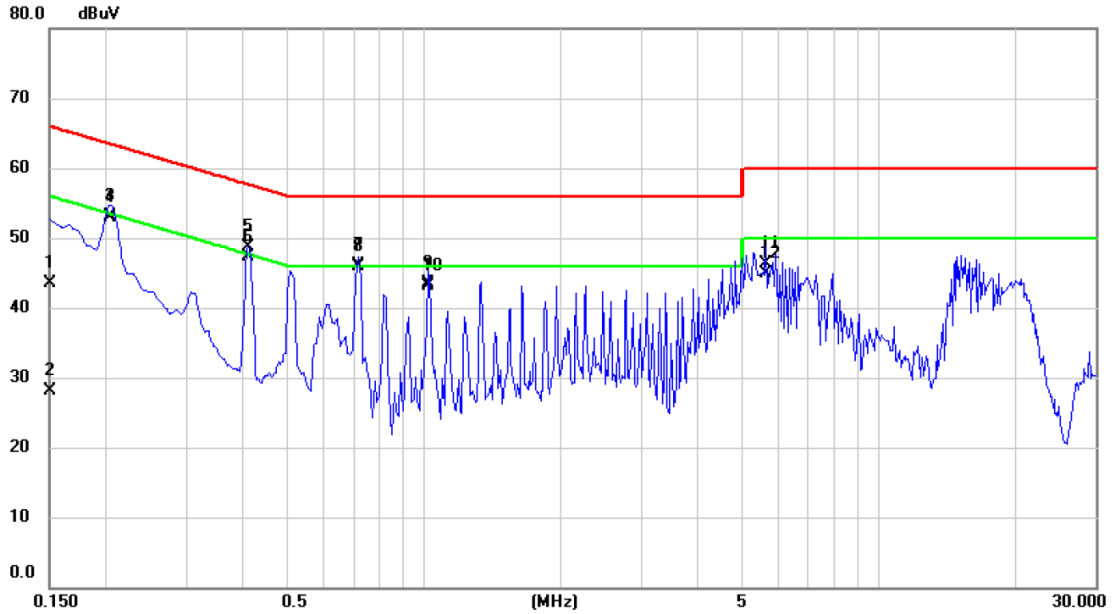

No.	Mk.	Freq. MHz	Reading Level dBuV	Correct Factor dB	Measurement dBuV	Limit dBuV	Margin dB	Detector	Comment
1		0.1500	33.80	9.66	43.46	66.00	-22.54	QP	
2		0.1500	18.50	9.66	28.16	56.00	-27.84	AVG	
3		0.2046	43.50	9.66	53.16	63.42	-10.26	QP	
4		0.2046	43.20	9.66	52.86	53.42	-0.56	AVG	
5		0.4118	39.00	9.66	48.66	57.61	-8.95	QP	
6		0.4118	37.70	9.66	47.36	47.61	-0.25	AVG	
7		0.7160	36.50	9.67	46.17	56.00	-9.83	QP	
8	*	0.7160	36.20	9.67	45.87	46.00	-0.13	AVG	
9		1.0220	33.80	9.67	43.47	56.00	-12.53	QP	
10		1.0220	33.50	9.67	43.17	46.00	-2.83	AVG	
11		5.6500	36.50	9.82	46.32	60.00	-13.68	QP	
12		5.6500	35.10	9.82	44.92	50.00	-5.08	AVG	

Test Mode: Normal LinI_PoE

Neutral

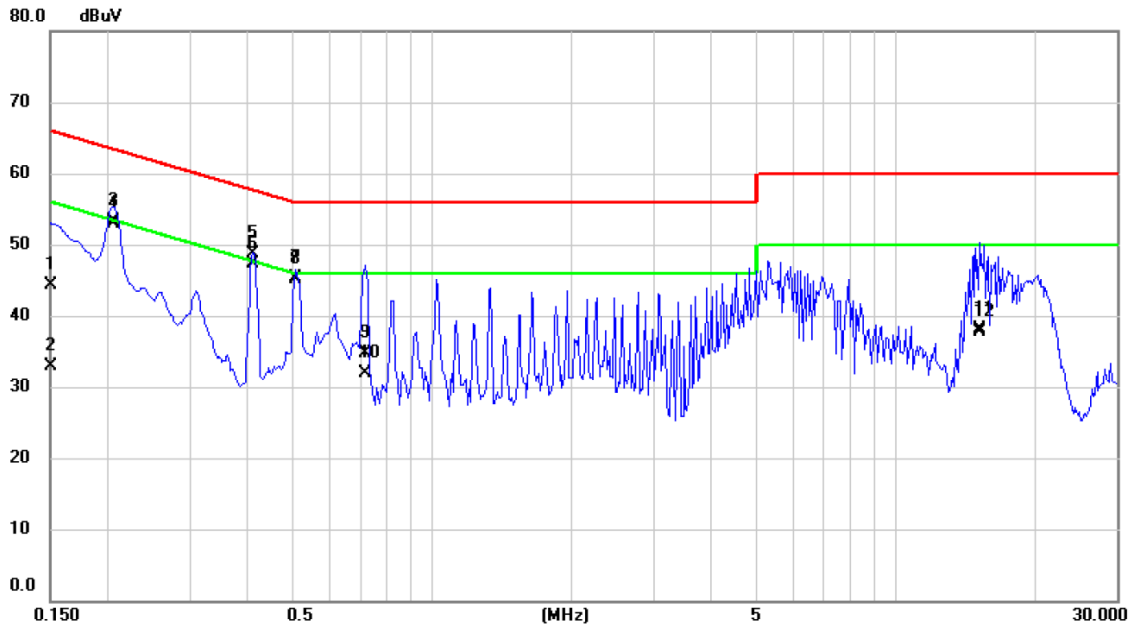

No.	Mk.	Freq. MHz	Reading Level dBuV	Correct Factor dB	Measure- ment dBuV	Limit dBuV	Margin dB	Detector	Comment
1		0.1500	34.60	9.67	44.27	66.00	-21.73	QP	
2		0.1500	23.20	9.67	32.87	56.00	-23.13	AVG	
3		0.2053	43.60	9.66	53.26	63.39	-10.13	QP	
4		0.2053	43.30	9.66	52.96	53.39	-0.43	AVG	
5		0.4118	39.00	9.66	48.66	57.61	-8.95	QP	
6	*	0.4118	37.70	9.66	47.36	47.61	-0.25	AVG	
7		0.5090	35.70	9.67	45.37	56.00	-10.63	QP	
8		0.5090	35.40	9.67	45.07	46.00	-0.93	AVG	
9		0.7160	25.00	9.68	34.68	56.00	-21.32	QP	
10		0.7160	22.30	9.68	31.98	46.00	-14.02	AVG	
11		15.2000	28.10	9.94	38.04	60.00	-21.96	QP	
12		15.2000	27.80	9.94	37.74	50.00	-12.26	AVG	

ATTACHMENT B - RADIATED EMISSION (9KHZ TO 30MHZ)

Test Mode: TX B MODE CHANNEL 01_Adapter

Ant 0°

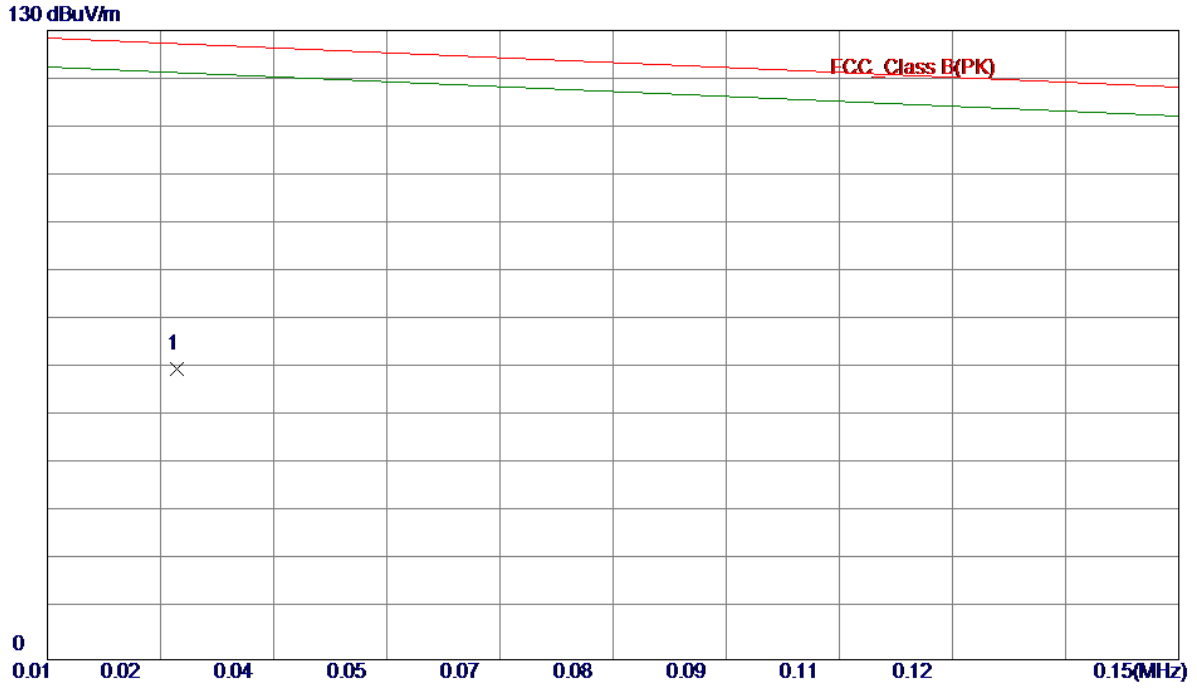

No.	Freq. MHz	Reading Level dBuV/m	Correct Factor dB	Measure ment dBuV/m	Limit dBuV/m	Margin dB	Detector	Comment
1 *	0.0251	43.66	16.33	59.99	127.35	-67.36	Peak	

Test Mode: TX B MODE CHANNEL 01_Adapter

Ant 0°

130 dBuV/m



No.	Freq. MHz	Reading Level dBuV/m	Correct Factor dB	Measure ment dBuV/m	Limit dBuV/m	Margin dB	Detector	Comment
1 *	0.5675	35.40	11.83	47.23	73.11	-25.88	Peak	
2	1.8810	24.44	11.60	36.04	69.54	-33.50	Peak	
3	4.3290	18.38	11.30	29.68	69.54	-39.86	Peak	
4	5.5230	15.90	11.39	27.29	69.54	-42.25	Peak	
5	7.0453	13.75	11.36	25.11	69.54	-44.43	Peak	
6	11.7911	12.65	11.25	23.90	69.54	-45.64	Peak	

Test Mode: TX B MODE CHANNEL 01_Adapter

Ant 90°

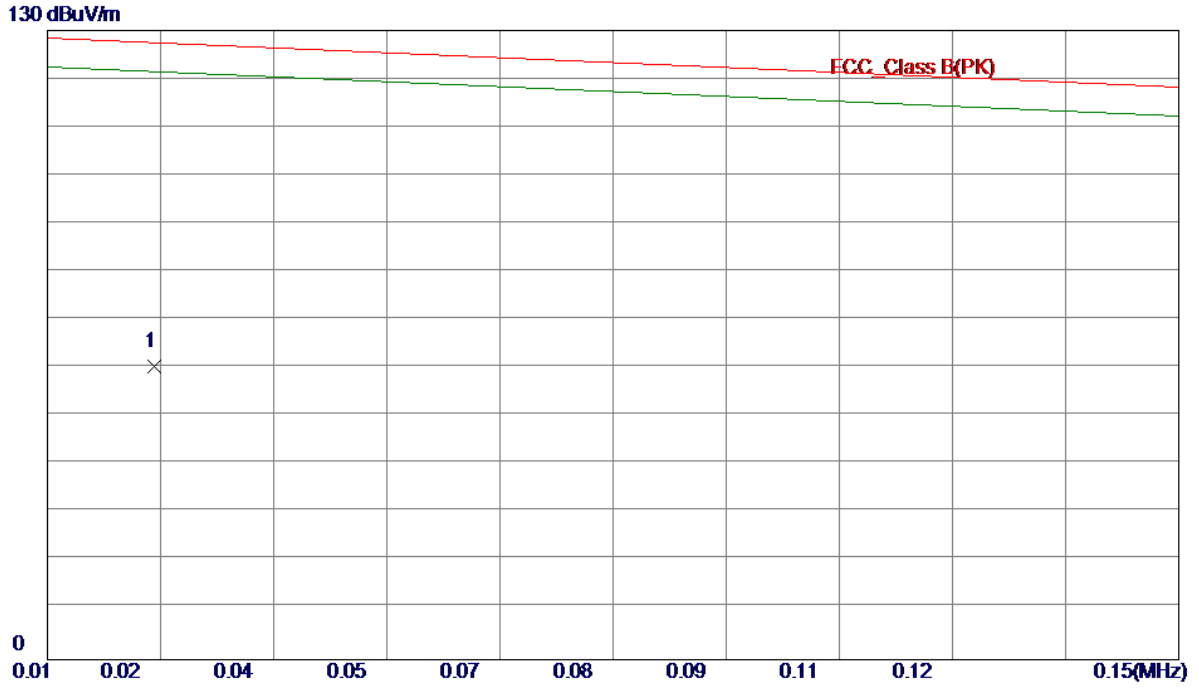

No.	Freq. MHz	Reading Level dBuV/m	Correct Factor dB	Measure ment dBuV/m	Limit dBuV/m	Margin dB	Detector	Comment
1 *	0.0223	43.56	17.10	60.66	127.55	-66.89	Peak	

Test Mode: TX B MODE CHANNEL 01_Adapter

Ant 90°

130 dBuV/m

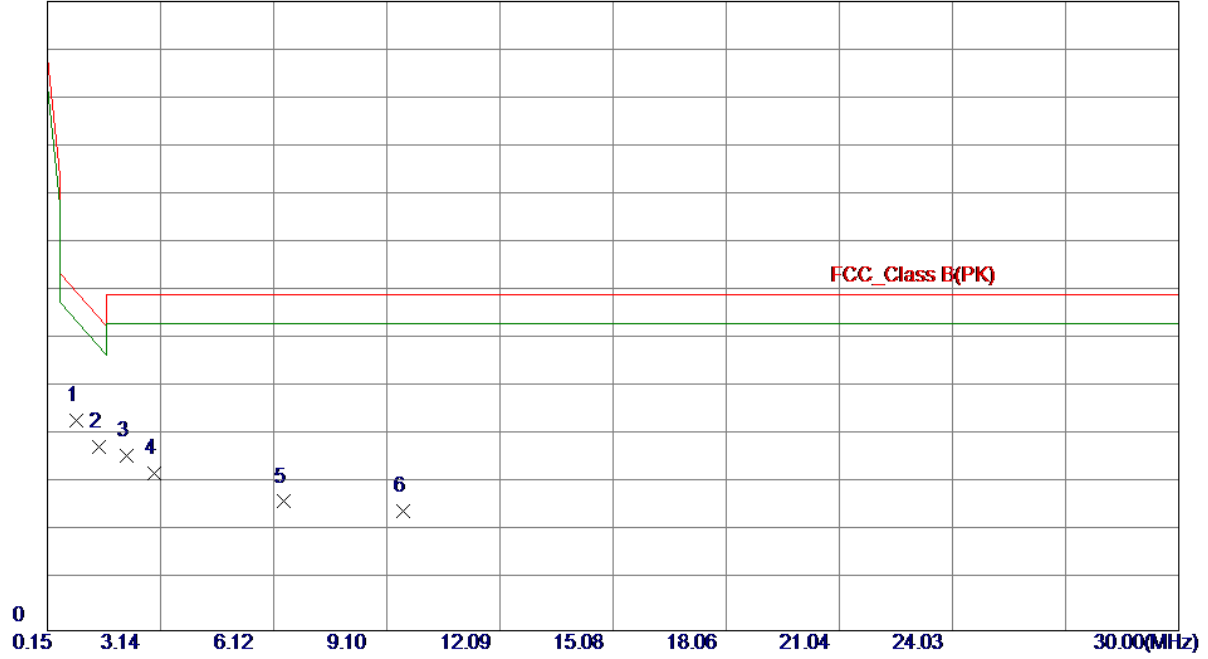

No.	Freq. MHz	Reading Level dBuV/m	Correct Factor dB	Measure ment dBuV/m	Limit dBuV/m	Margin dB	Detector	Comment
1 *	0.9261	31.48	11.97	43.45	69.91	-26.46	Peak	
2	1.5230	26.24	11.76	38.00	64.59	-26.59	Peak	
3	2.2395	24.62	11.44	36.06	69.54	-33.48	Peak	
4	2.9560	21.26	11.12	32.38	69.54	-37.16	Peak	
5	6.3887	15.28	11.37	26.65	69.54	-42.89	Peak	
6	9.5228	13.44	11.31	24.75	69.54	-44.79	Peak	

Test Mode: TX B MODE CHANNEL 01_PoE

Ant 0°

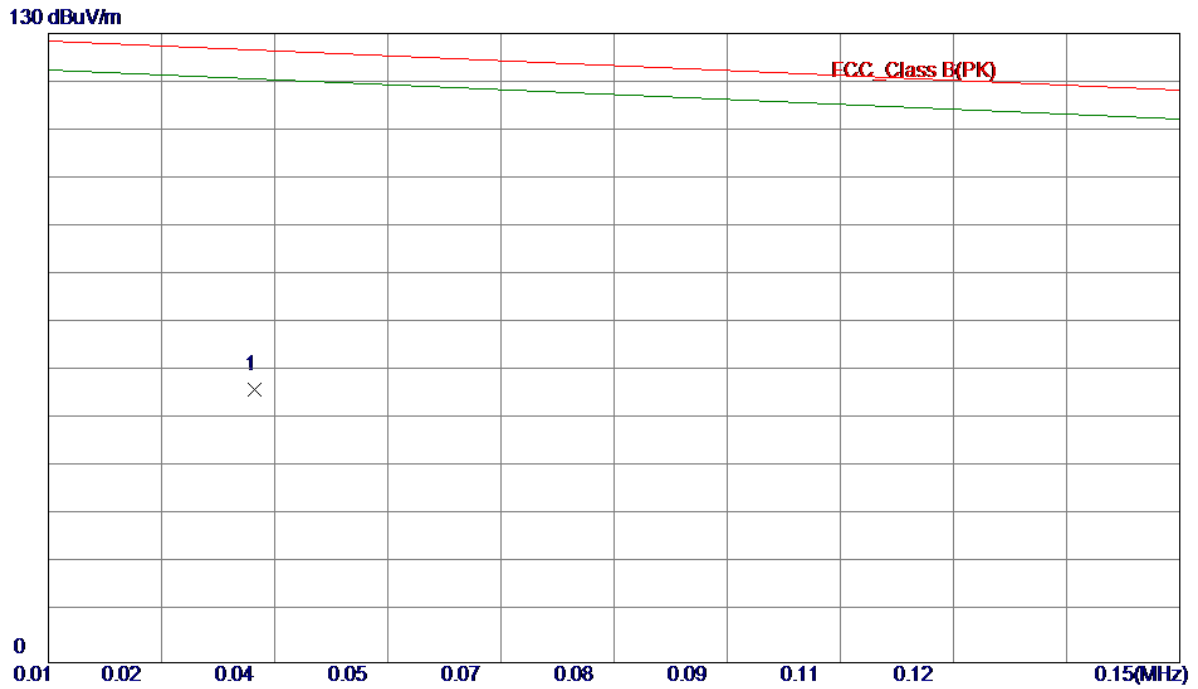

No.	Freq. MHz	Reading Level dBuV/m	Correct Factor dB	Measure ment dBuV/m	Limit dBuV/m	Margin dB	Detector	Comment
1 *	0.0347	41.88	14.52	56.40	126.66	-70.26	Peak	

Test Mode: TX B MODE CHANNEL 01_PoE

Ant 0°

130 dBuV/m

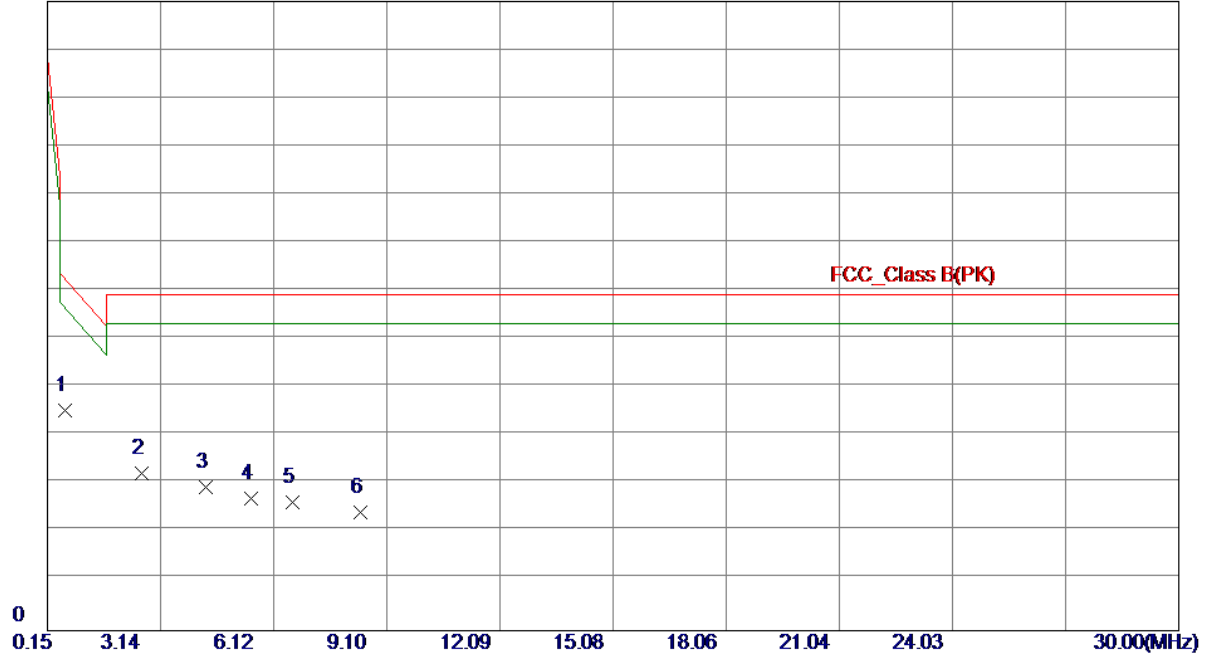

No.	Freq. MHz	Reading Level dBuV/m	Correct Factor dB	Measurement dBuV/m	Limit dBuV/m	Margin dB	Detector	Comment
1 *	0.6276	33.55	11.85	45.40	72.57	-27.17	Peak	
2	2.6274	21.29	11.27	32.56	69.54	-36.98	Peak	
3	4.3290	18.38	11.30	29.68	69.54	-39.86	Peak	
4	5.5230	15.90	11.39	27.29	69.54	-42.25	Peak	
5	6.6272	15.26	11.37	26.63	69.54	-42.91	Peak	
6	8.4184	13.23	11.33	24.56	69.54	-44.98	Peak	

Test Mode: TX B MODE CHANNEL 01_PoE

Ant 90°

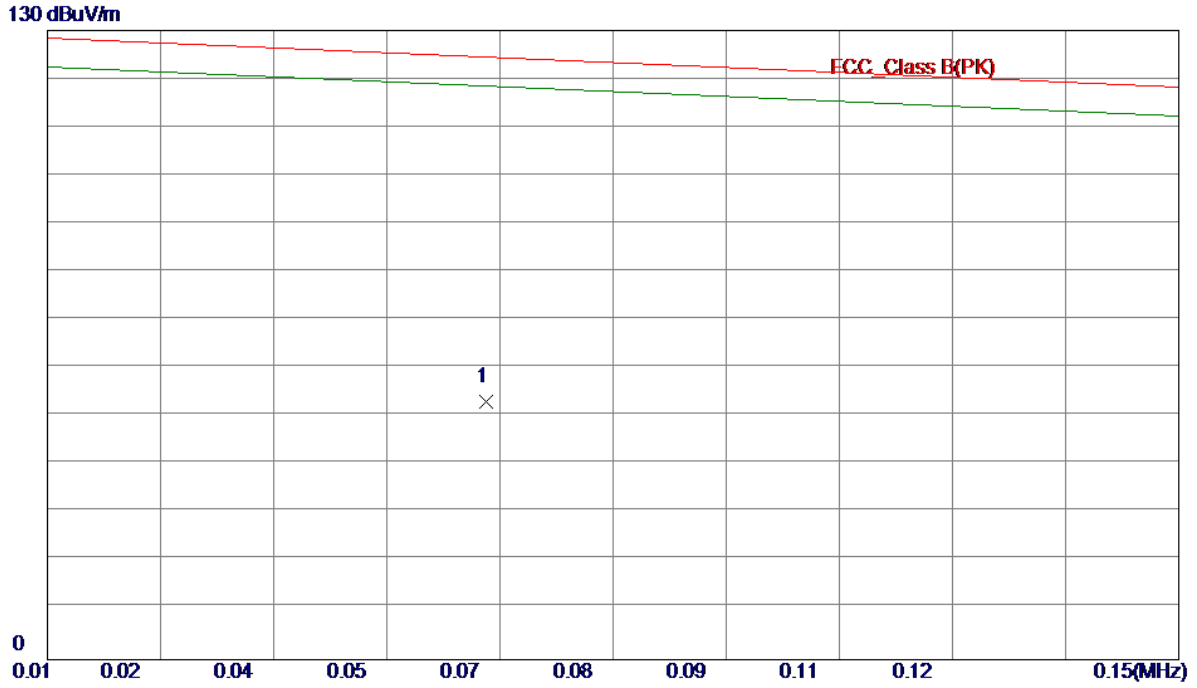

No.	Freq. MHz	Reading Level dBuV/m	Correct Factor dB	Measure ment dBuV/m	Limit dBuV/m	Margin dB	Detector	Comment
1 *	0.0637	40.61	12.75	53.36	124.56	-71.20	Peak	

Test Mode: TX B MODE CHANNEL 01_PoE

Ant 90°

130 dBuV/m

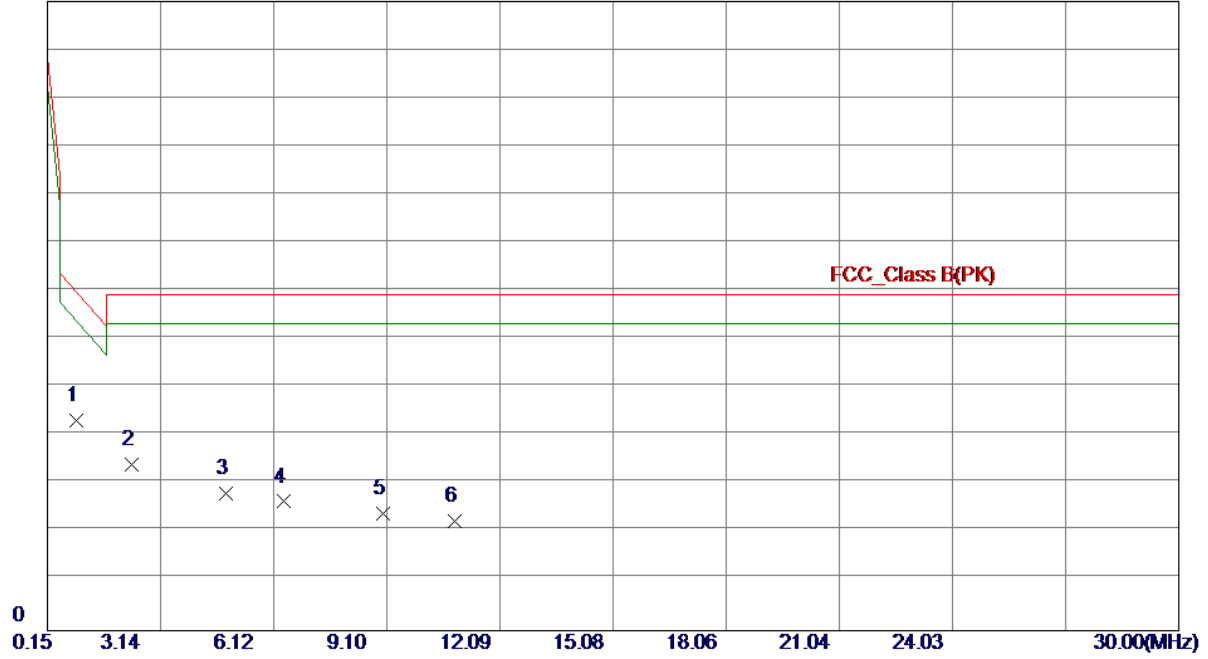

No.	Freq. MHz	Reading Level dBuV/m	Correct Factor dB	Measurement dBuV/m	Limit dBuV/m	Margin dB	Detector	Comment
1 *	0.9261	31.48	11.97	43.45	69.91	-26.46	Peak	
2	2.3887	22.98	11.38	34.36	69.54	-35.18	Peak	
3	4.8662	16.94	11.38	28.32	69.54	-41.22	Peak	
4	6.3887	15.28	11.37	26.65	69.54	-42.89	Peak	
5	9.0152	12.79	11.32	24.11	69.54	-45.43	Peak	
6	10.8959	11.23	11.27	22.50	69.54	-47.04	Peak	

Test Mode: TX B MODE CHANNEL 01_Battery

Ant 0°

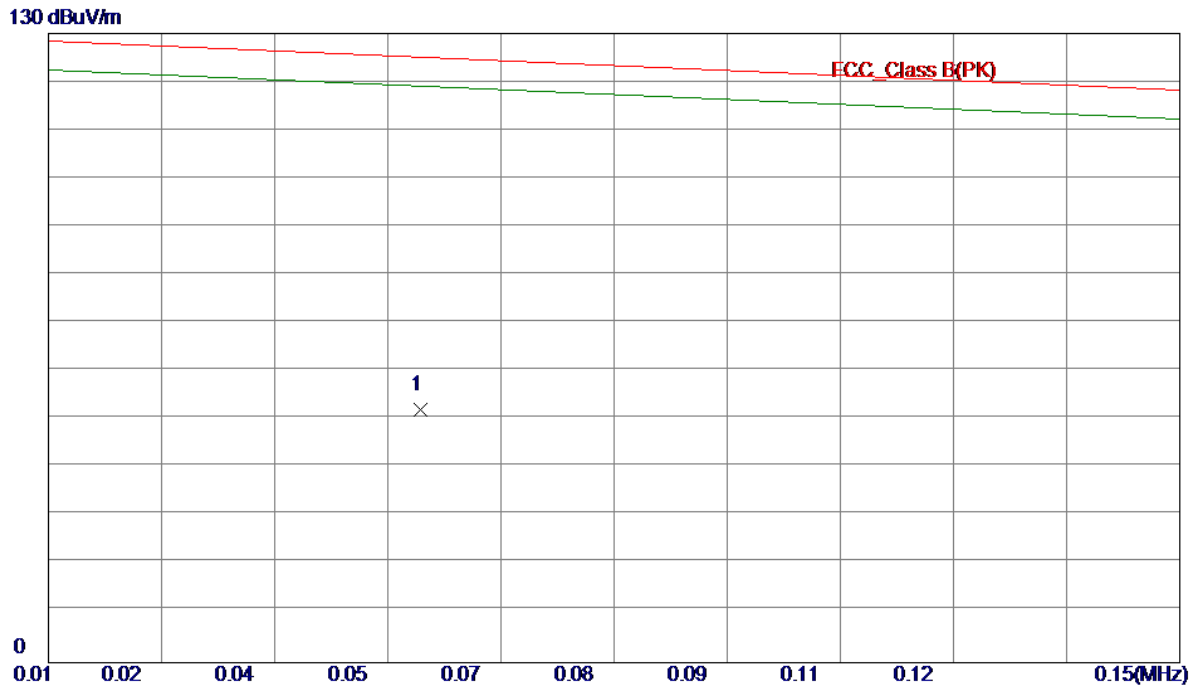

No.	Freq. MHz	Reading Level dBuV/m	Correct Factor dB	Measure ment dBuV/m	Limit dBuV/m	Margin dB	Detector	Comment
1 *	0.0553	39.28	12.90	52.18	125.17	-72.99	Peak	

Test Mode: TX B MODE CHANNEL 01_Battery

Ant 0°

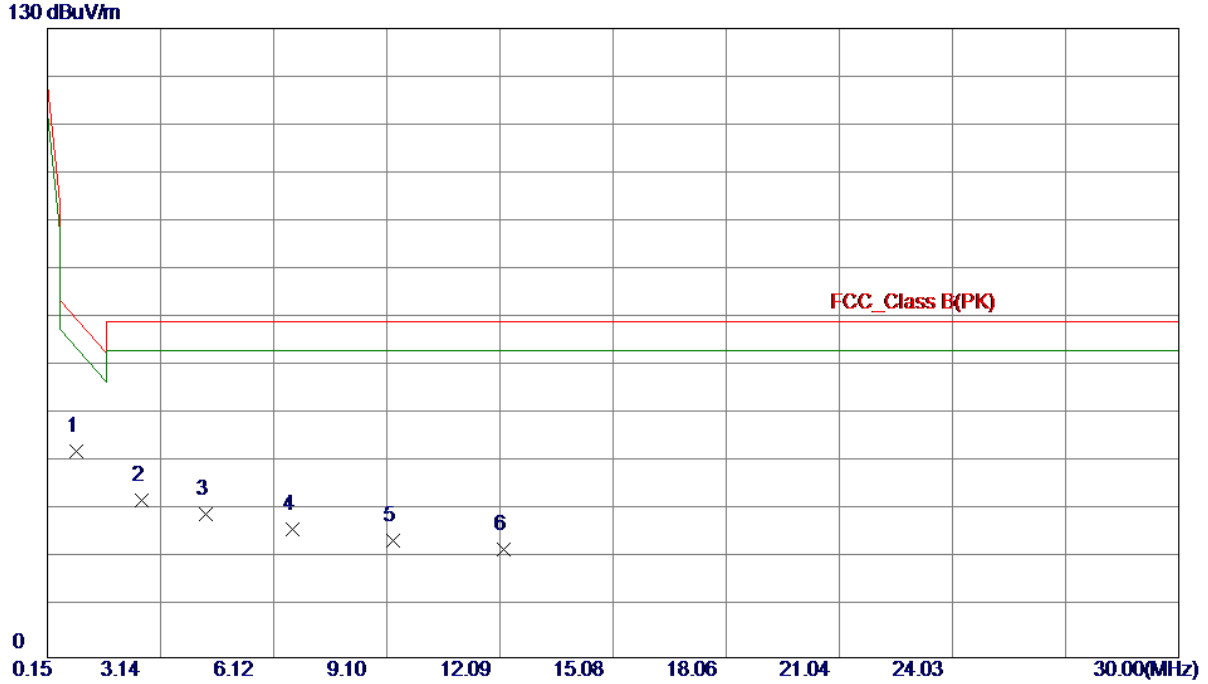

No.	Freq. MHz	Reading Level dBuV/m	Correct Factor dB	Measure ment dBuV/m	Limit dBuV/m	Margin dB	Detector	Comment
1 *	0.9261	30.79	11.97	42.76	69.91	-27.15	Peak	
2	2.6274	21.29	11.27	32.56	69.54	-36.98	Peak	
3	4.3290	18.38	11.30	29.68	69.54	-39.86	Peak	
4	6.6272	15.26	11.37	26.63	69.54	-42.91	Peak	
5	9.2543	12.76	11.31	24.07	69.54	-45.47	Peak	
6	12.1796	11.03	11.23	22.26	69.54	-47.28	Peak	

Test Mode: TX B MODE CHANNEL 01_Battery

Ant 90°

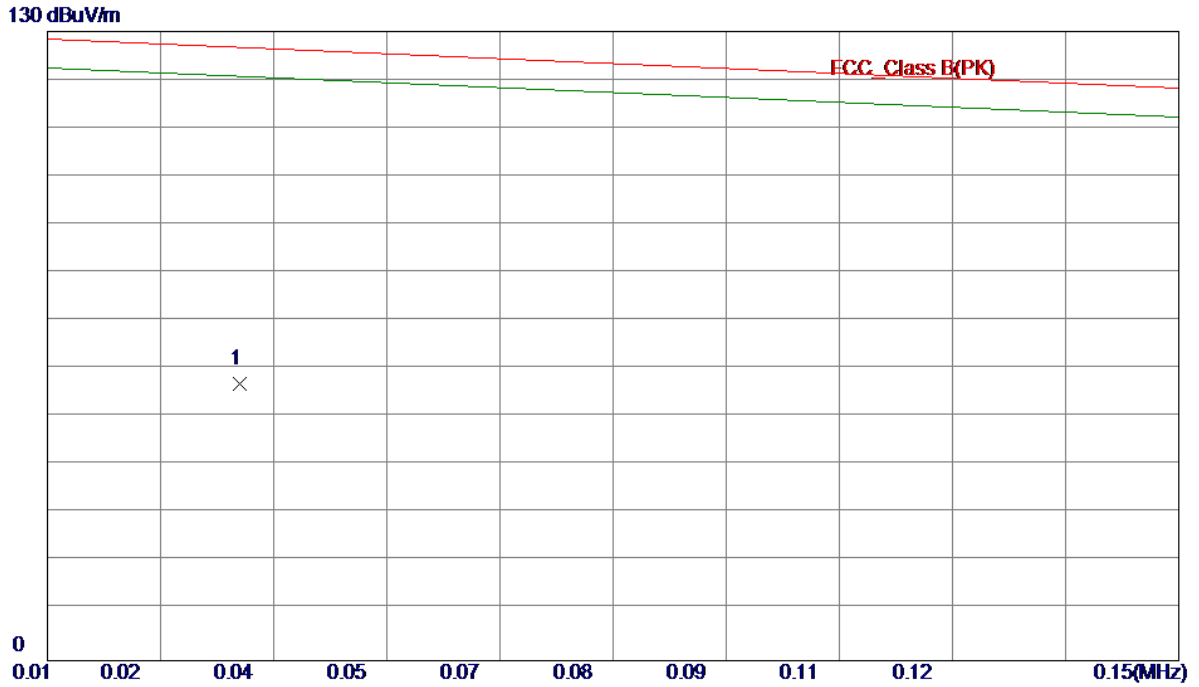

No.	Freq. MHz	Reading Level dBuV/m	Correct Factor dB	Measure ment dBuV/m	Limit dBuV/m	Margin dB	Detector	Comment
1 *	0.0330	42.60	14.69	57.29	126.78	-69.49	Peak	

Test Mode: TX B MODE CHANNEL 01_Battery

Ant 90°

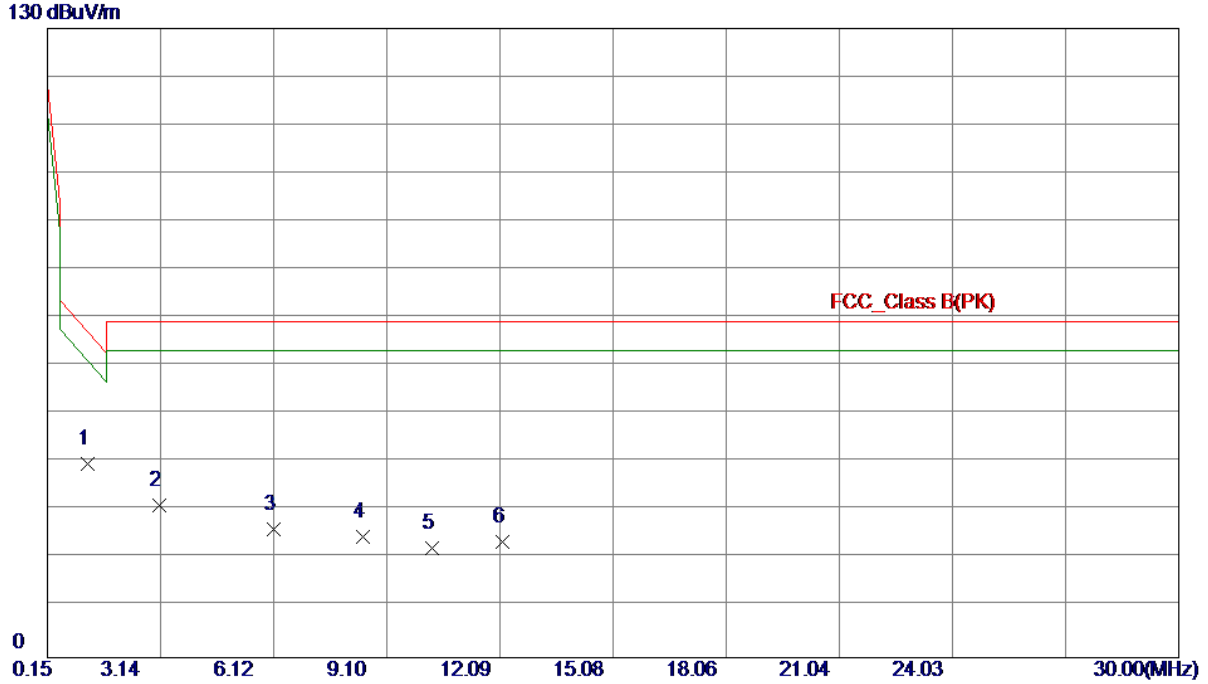

No.	Freq. MHz	Reading Level dBuV/m	Correct Factor dB	Measure ment dBuV/m	Limit dBuV/m	Margin dB	Detector	Comment
1 *	1.2240	28.18	11.90	40.08	67.26	-27.18	Peak	
2	3.1051	20.33	11.12	31.45	69.54	-38.09	Peak	
3	6.1200	15.19	11.38	26.57	69.54	-42.97	Peak	
4	8.4780	13.54	11.33	24.87	69.54	-44.67	Peak	
5	10.2990	11.36	11.29	22.65	69.54	-46.89	Peak	
6	12.1493	12.61	11.24	23.85	69.54	-45.69	Peak	

ATTACHMENT C - RADIATED EMISSION (30MHZ TO 1000MHZ)

Test Mode: TX B MODE CHANNEL 11_Adapter

Vertical

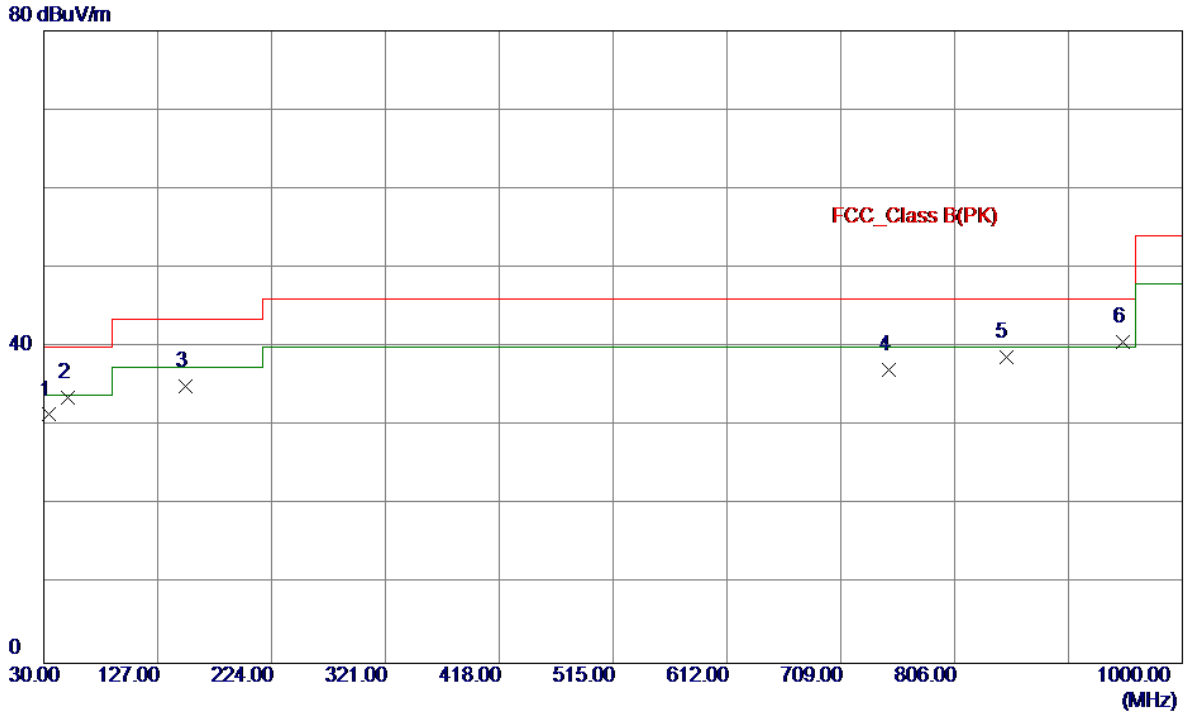

No.	Freq. MHz	Reading Level dBuV/m	Correct Factor dB	Measure ment dBuV/m	Limit dBuV/m	Margin dB	Detector	Comment
1	33.8800	40.52	-9.08	31.44	40.00	-8.56	Peak	
2	50.3700	42.04	-8.42	33.62	40.00	-6.38	Peak	
3	150.2800	43.99	-8.95	35.04	43.50	-8.46	Peak	
4	749.7400	35.18	1.88	37.06	46.00	-8.94	Peak	
5	849.6500	35.54	3.12	38.66	46.00	-7.34	Peak	
6 *	949.5600	35.62	4.98	40.60	46.00	-5.40	Peak	

Test Mode: TX B MODE CHANNEL 11_Adapter

Horizontal

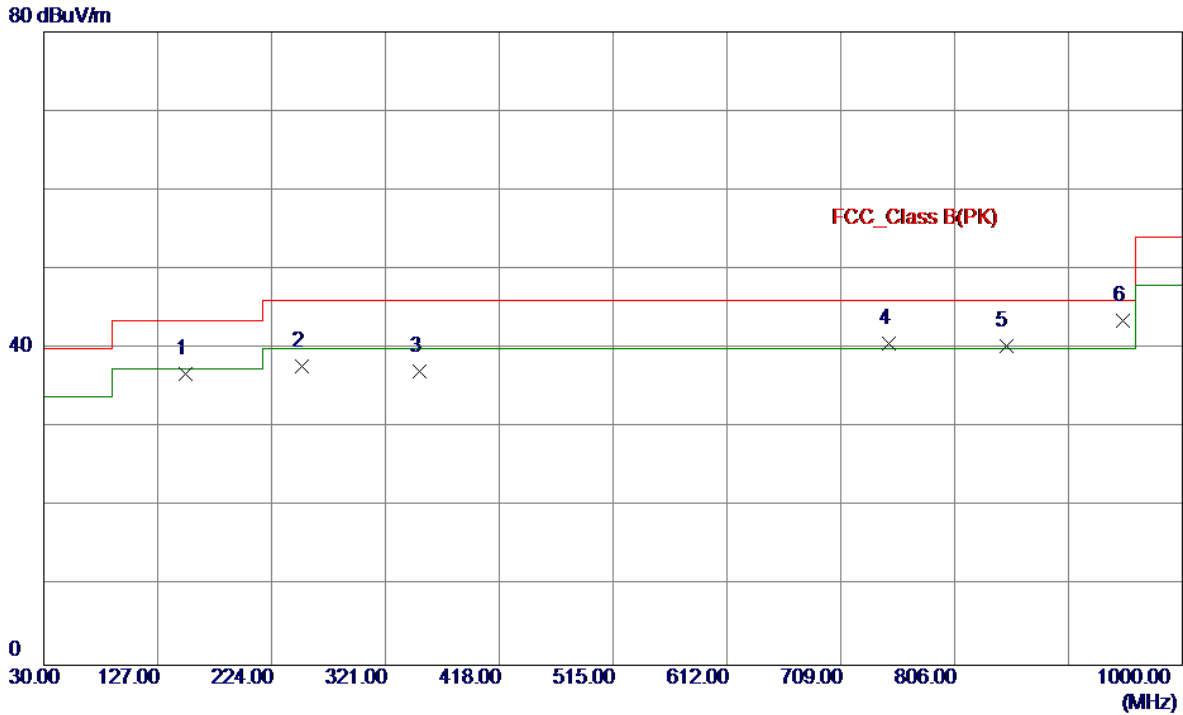

No.	Freq. MHz	Reading Level dBuV/m	Correct Factor dB	Measure ment dBuV/m	Limit dBuV/m	Margin dB	Detector	Comment
1	150.2800	45.73	-8.95	36.78	43.50	-6.72	Peak	
2	250.1900	47.18	-9.47	37.71	46.00	-8.29	Peak	
3	350.1000	43.53	-6.34	37.19	46.00	-8.81	Peak	
4	749.7400	38.73	1.88	40.61	46.00	-5.39	Peak	
5	849.6500	37.13	3.12	40.25	46.00	-5.75	Peak	
6 *	949.5600	38.58	4.98	43.56	46.00	-2.44	Peak	

Test Mode: TX B MODE CHANNEL 11_PoE

Vertical

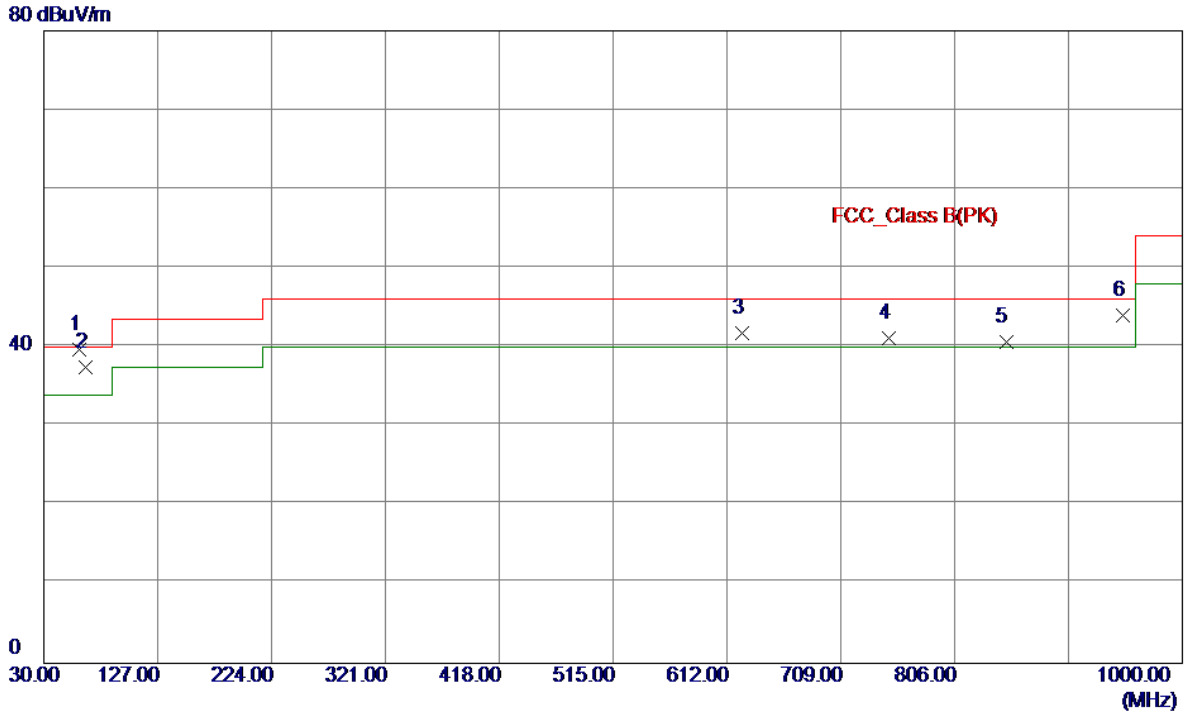

No.	Freq. MHz	Reading Level dBuV/m	Correct Factor dB	Measure ment dBuV/m	Limit dBuV/m	Margin dB	Detector	Comment
1 *	60.0700	48.69	-9.01	39.68	40.00	-0.32	QP	
2	65.8900	47.36	-9.98	37.38	40.00	-2.62	Peak	
3	624.6100	42.24	-0.43	41.81	46.00	-4.19	Peak	
4	749.7400	39.18	1.88	41.06	46.00	-4.94	Peak	
5	849.6500	37.49	3.12	40.61	46.00	-5.39	Peak	
6	949.5600	39.02	4.98	44.00	46.00	-2.00	Peak	

Test Mode: TX B MODE CHANNEL 11_PoE

Horizontal

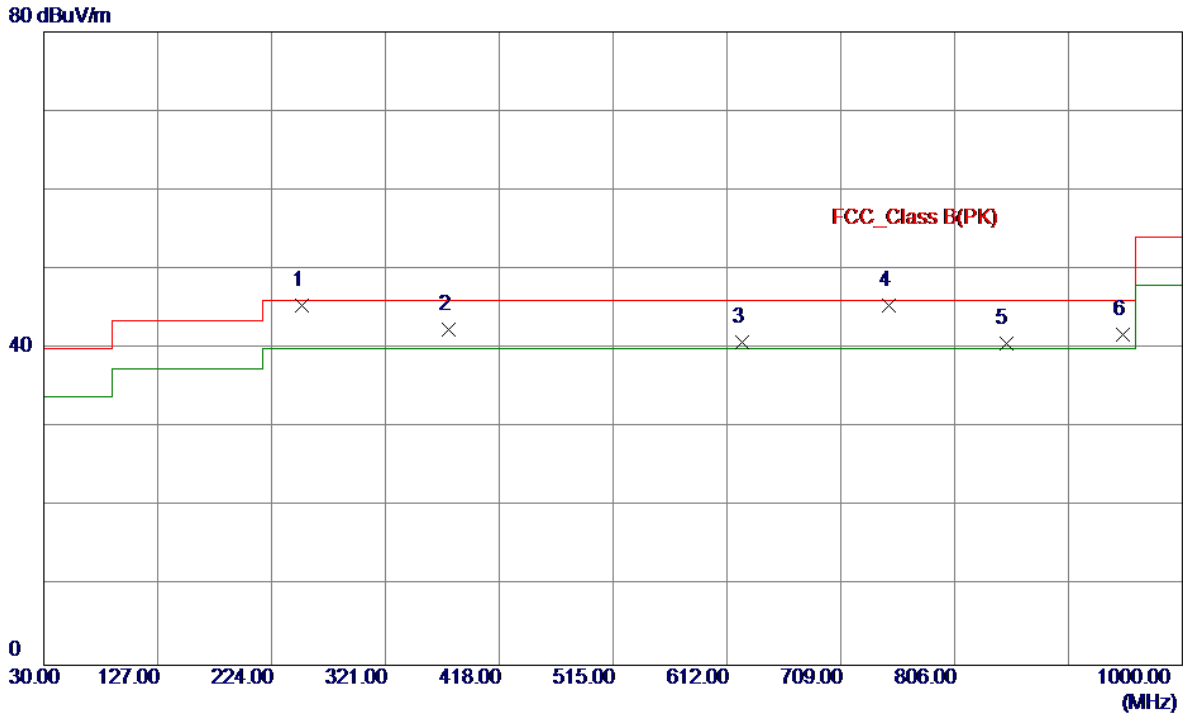

No.	Freq. MHz	Reading Level dBuV/m	Correct Factor dB	Measure ment dBuV/m	Limit dBuV/m	Margin dB	Detector	Comment
1 *	250.1900	54.90	-9.47	45.43	46.00	-0.57	QP	
2	375.3200	48.13	-5.78	42.35	46.00	-3.65	Peak	
3	624.6100	41.23	-0.43	40.80	46.00	-5.20	Peak	
4	749.7400	43.55	1.88	45.43	46.00	-0.57	QP	
5	849.6500	37.53	3.12	40.65	46.00	-5.35	Peak	
6	949.5600	36.78	4.98	41.76	46.00	-4.24	Peak	

Test Mode: TX B MODE CHANNEL 11_Battery

Vertical

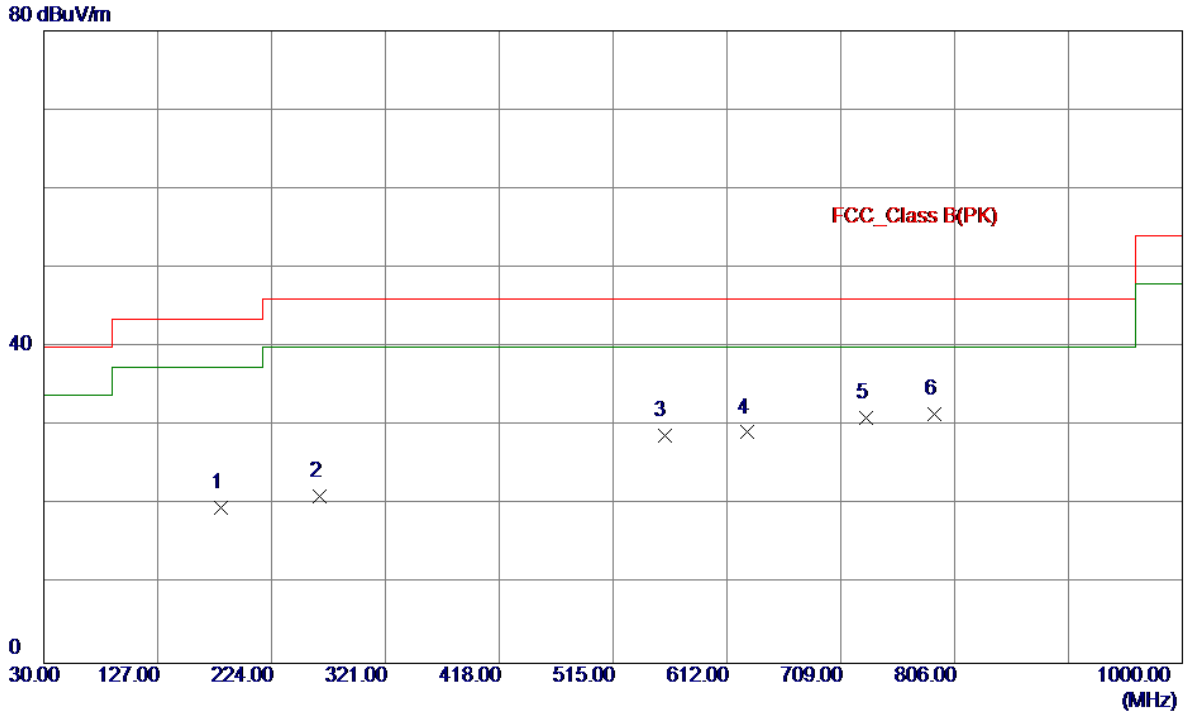

No.	Freq. MHz	Reading Level dBuV/m	Correct Factor dB	Measure ment dBuV/m	Limit dBuV/m	Margin dB	Detector	Comment
1	181.3200	29.86	-10.21	19.65	43.50	-23.85	Peak	
2	264.7400	29.97	-8.86	21.11	46.00	-24.89	Peak	
3	558.6500	30.56	-1.70	28.86	46.00	-17.14	Peak	
4	629.4600	29.59	-0.39	29.20	46.00	-16.80	Peak	
5	730.3400	29.50	1.49	30.99	46.00	-15.01	Peak	
6 *	788.5400	29.15	2.30	31.45	46.00	-14.55	Peak	

Test Mode: TX B MODE CHANNEL 11_Battery

Horizontal

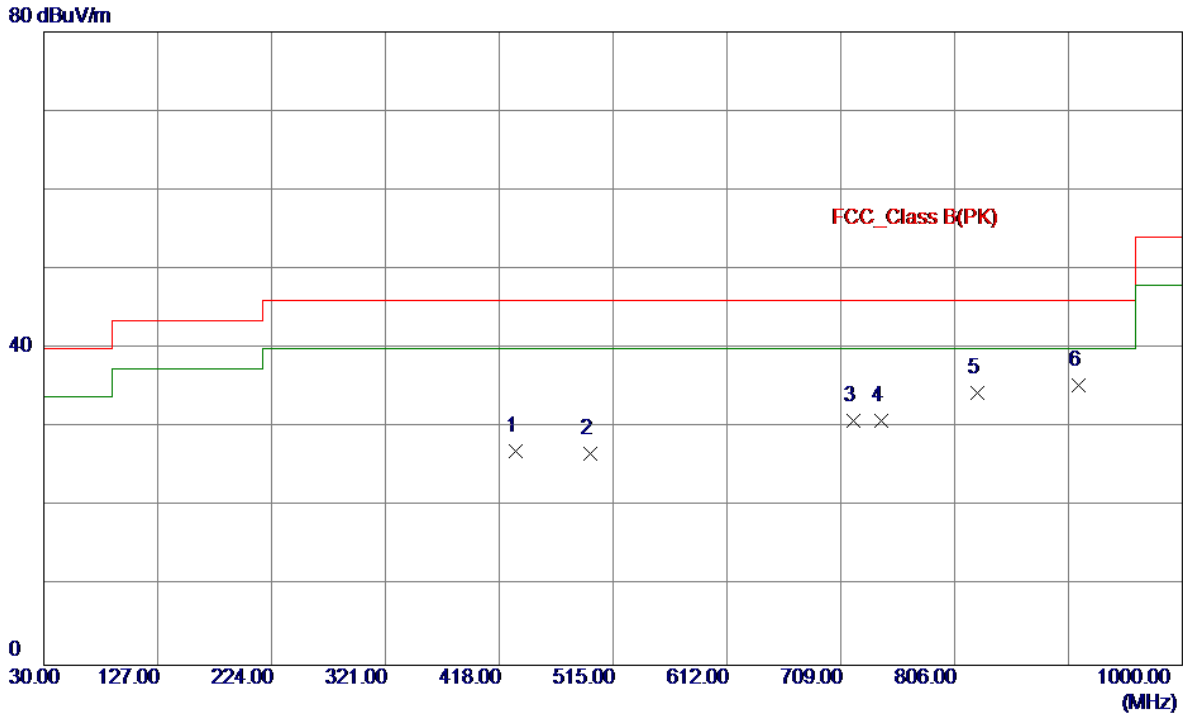

No.	Freq. MHz	Reading Level dBuV/m	Correct Factor dB	Measure ment dBuV/m	Limit dBuV/m	Margin dB	Detector	Comment
1	431.5800	31.36	-4.37	26.99	46.00	-19.01	Peak	
2	495.6000	29.78	-3.10	26.68	46.00	-19.32	Peak	
3	719.6700	29.68	1.27	30.95	46.00	-15.05	Peak	
4	742.9500	29.17	1.74	30.91	46.00	-15.09	Peak	
5	825.4000	31.68	2.78	34.46	46.00	-11.54	Peak	
6 *	911.7300	30.97	4.32	35.29	46.00	-10.71	Peak	

ATTACHMENT D - RADIATED EMISSION (ABOVE 1000MHZ)

Orthogonal Axis :	X
Test Mode :	TX B MODE 2412MHz

Vertical

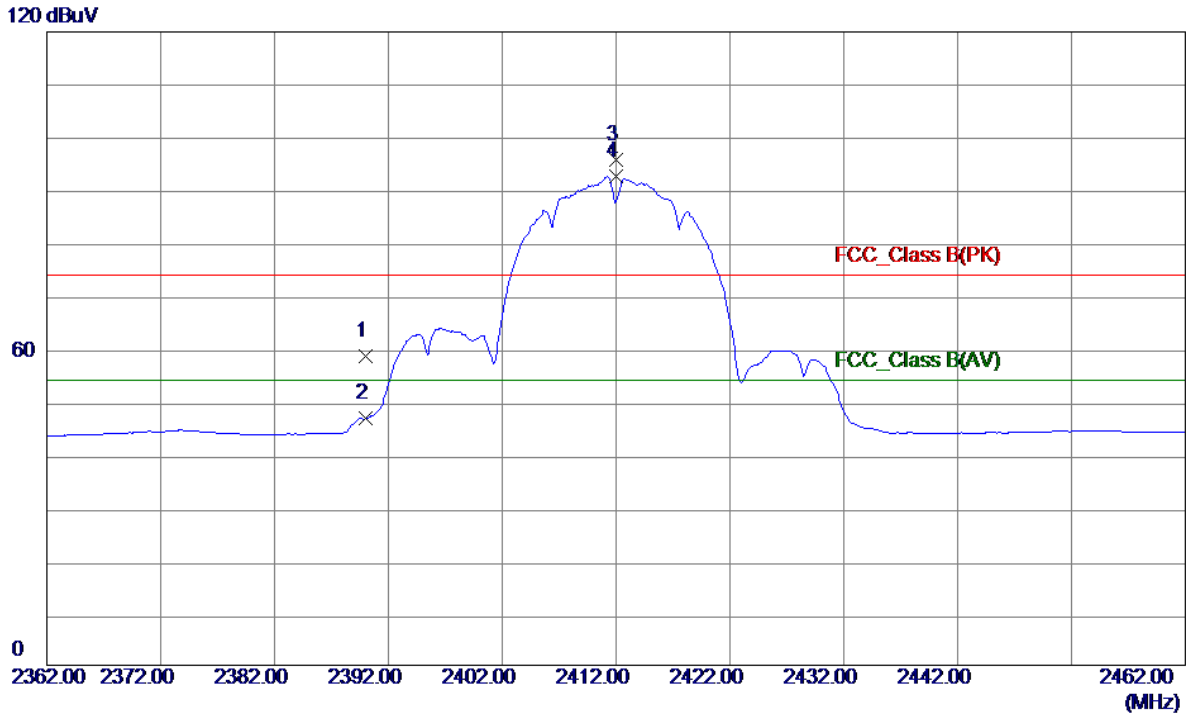

No.	Freq. MHz	Reading Level dBuV	Correct Factor dB	Measure ment dBuV	Limit dBuV	Margin dB	Detector	Comment
1	2390.0000	27.56	30.97	58.53	74.00	-15.47	Peak	
2	2390.0000	15.79	30.97	46.76	54.00	-7.24	AVG	
3	2412.0000	64.81	31.05	95.86	74.00	21.86	Peak	No Limit
4 *	2412.0000	61.54	31.05	92.59	54.00	38.59	AVG	No Limit

Orthogonal Axis :	X
Test Mode :	TX B MODE 2412MHz

Vertical

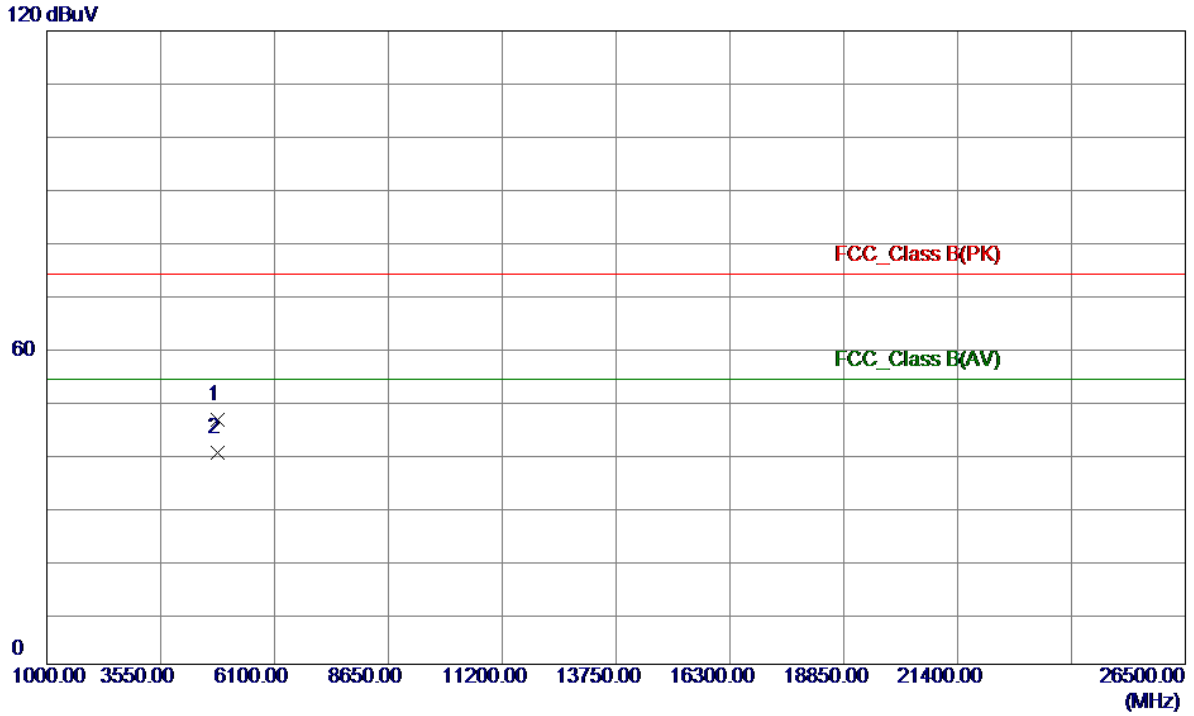

No.	Freq. MHz	Reading Level dBuV	Correct Factor dB	Measure ment dBuV	Limit dBuV	Margin dB	Detector	Comment
1	4824.0000	57.76	-11.47	46.29	74.00	-27.71	Peak	
2 *	4824.0000	51.50	-11.47	40.03	54.00	-13.97	AVG	

Orthogonal Axis :	X
Test Mode :	TX B MODE 2412MHz

Horizontal

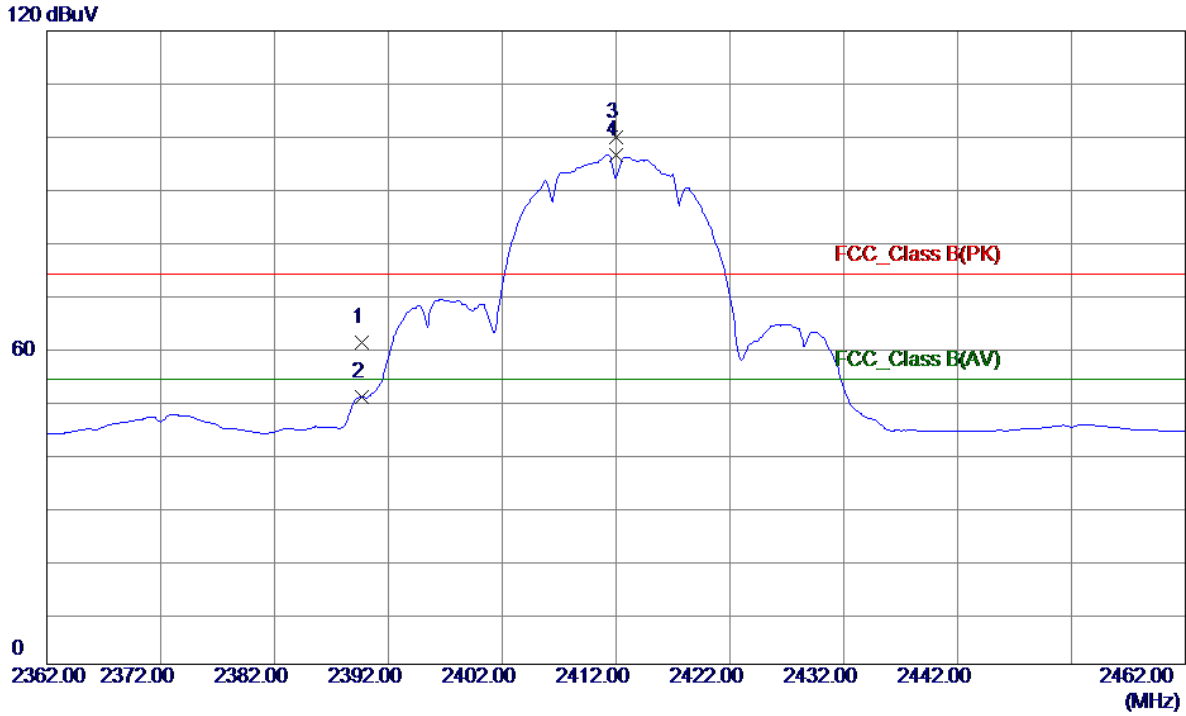

No.	Freq. MHz	Reading Level dBuV	Correct Factor dB	Measure ment dBuV	Limit dBuV	Margin dB	Detector	Comment
1	2389.6359	30.06	30.96	61.02	74.00	-12.98	Peak	
2	2389.6359	19.70	30.96	50.66	54.00	-3.34	AVG	
3	2412.0000	68.80	31.05	99.85	74.00	25.85	Peak	No Limit
4 *	2412.0000	65.54	31.05	96.59	54.00	42.59	AVG	No Limit

Orthogonal Axis :	X
Test Mode :	TX B MODE 2412MHz

Horizontal

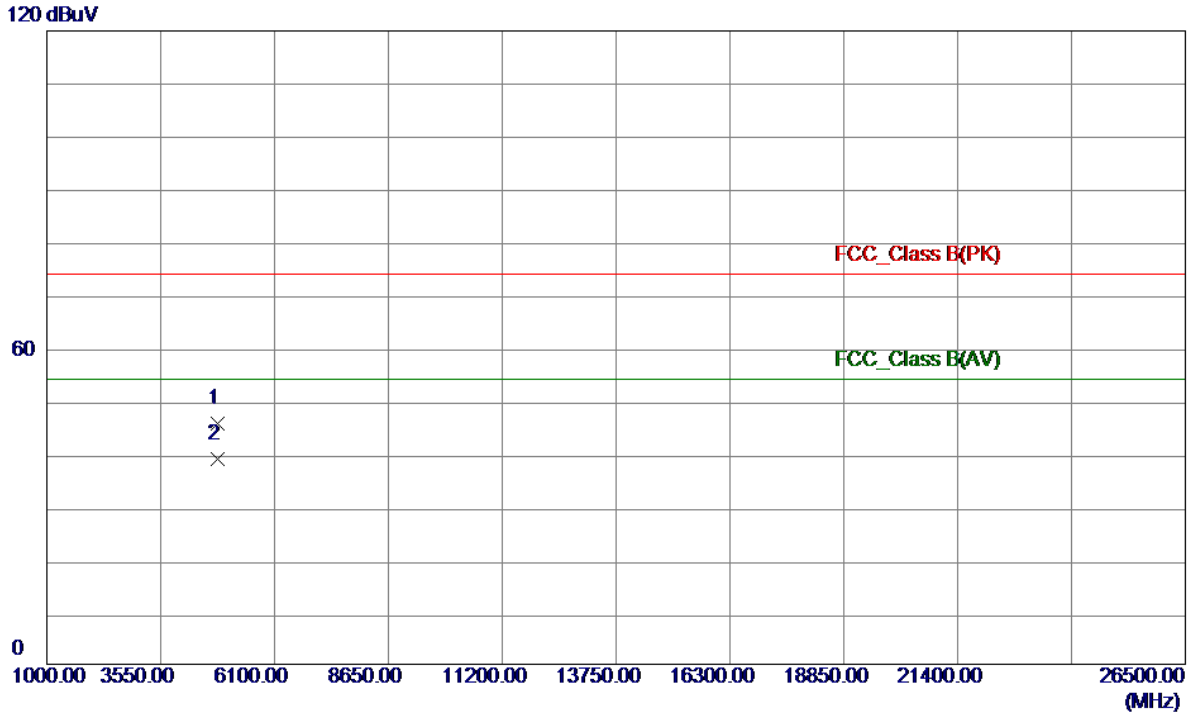

No.	Freq. MHz	Reading Level dBuV	Correct Factor dB	Measure ment dBuV	Limit dBuV	Margin dB	Detector	Comment
1	4824.0000	57.09	-11.47	45.62	74.00	-28.38	Peak	
2 *	4824.0000	50.24	-11.47	38.77	54.00	-15.23	AVG	

Orthogonal Axis :	X
Test Mode :	TX B MODE 2437MHz

Vertical

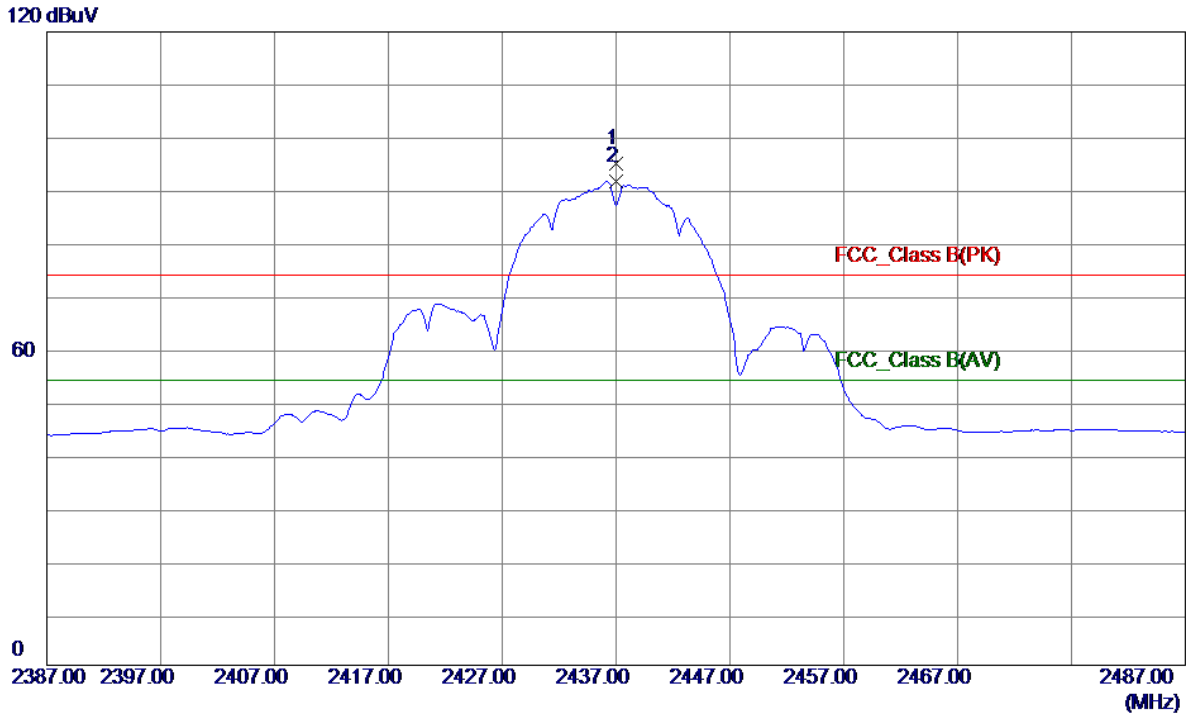

No.	Freq. MHz	Reading Level dBuV	Correct Factor dB	Measure ment dBuV	Limit dBuV	Margin dB	Detector	Comment
1	2437.0000	63.87	31.14	95.01	74.00	21.01	Peak	No Limit
2 *	2437.0000	60.52	31.14	91.66	54.00	37.66	AVG	No Limit

Orthogonal Axis :	X
Test Mode :	TX B MODE 2437MHz

Vertical

120 dBuV

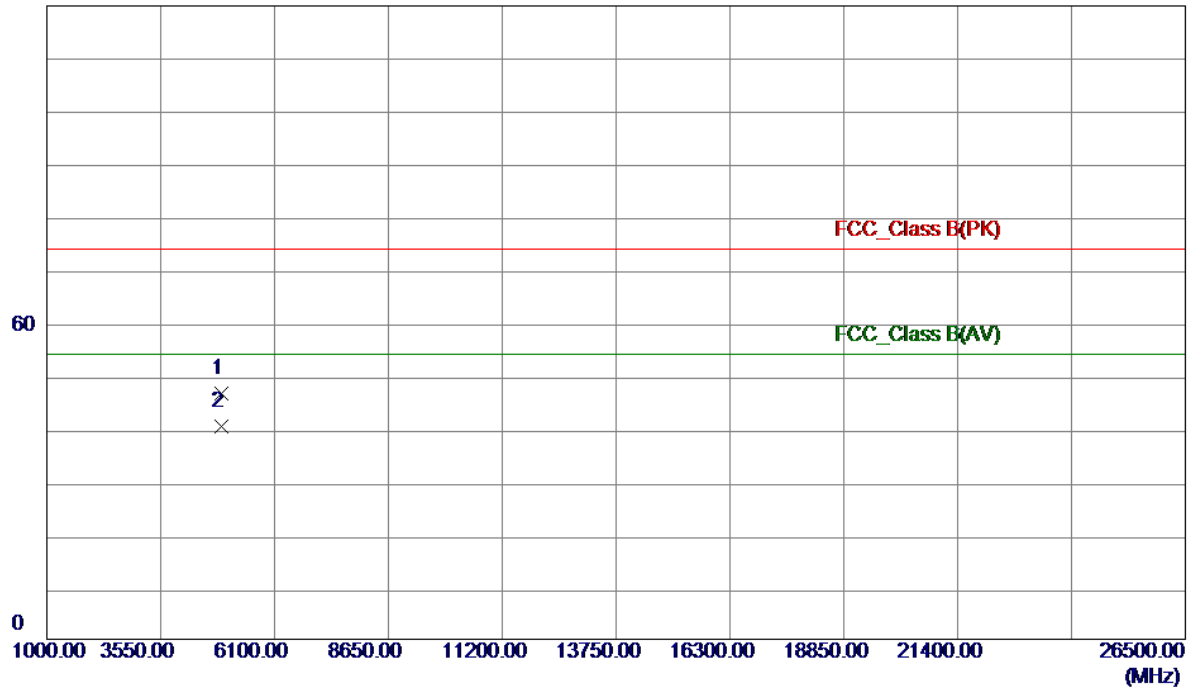

No.	Freq. MHz	Reading Level dBuV	Correct Factor dB	Measure ment dBuV	Limit dBuV	Margin dB	Detector	Comment
1	4924.0000	57.93	-11.32	46.61	74.00	-27.39	Peak	
2 *	4924.0000	51.56	-11.32	40.24	54.00	-13.76	AVG	

Orthogonal Axis :	X
Test Mode :	TX B MODE 2437MHz

Vertical

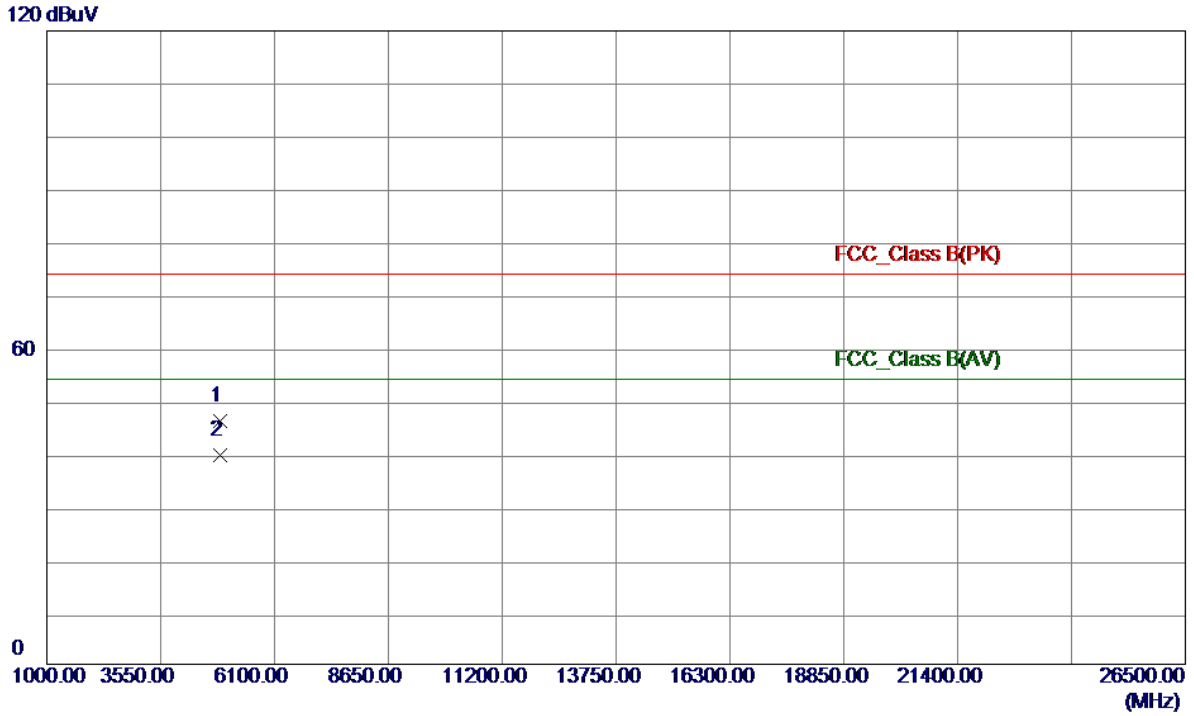

No.	Freq. MHz	Reading Level dBuV	Correct Factor dB	Measure ment dBuV	Limit dBuV	Margin dB	Detector	Comment
1	4874.0000	57.57	-11.39	46.18	74.00	-27.82	Peak	
2 *	4874.0000	51.10	-11.39	39.71	54.00	-14.29	AVG	

Orthogonal Axis :	X
Test Mode :	TX B MODE 2437MHz

Horizontal

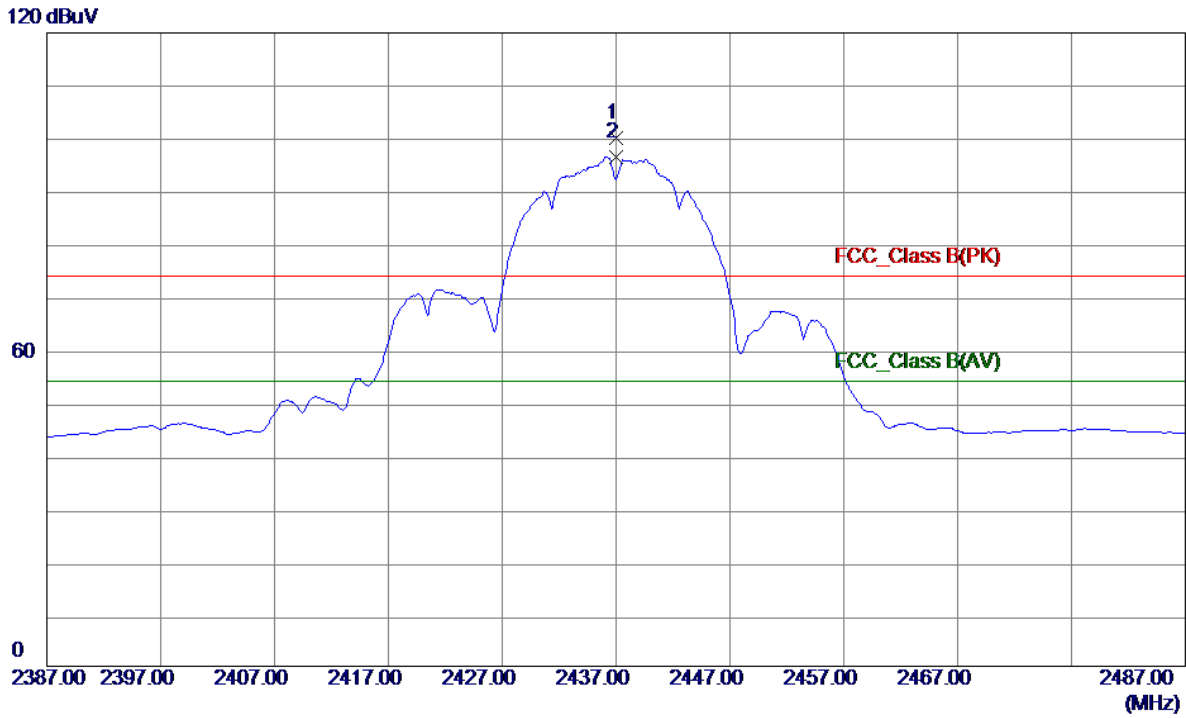

No.	Freq. MHz	Reading Level dBuV	Correct Factor dB	Measure ment dBuV	Limit dBuV	Margin dB	Detector	Comment
1	2437.0000	68.84	31.14	99.98	74.00	25.98	Peak	No Limit
2 *	2437.0000	65.36	31.14	96.50	54.00	42.50	AVG	No Limit

Orthogonal Axis :	X
Test Mode :	TX B MODE 2437MHz

Horizontal

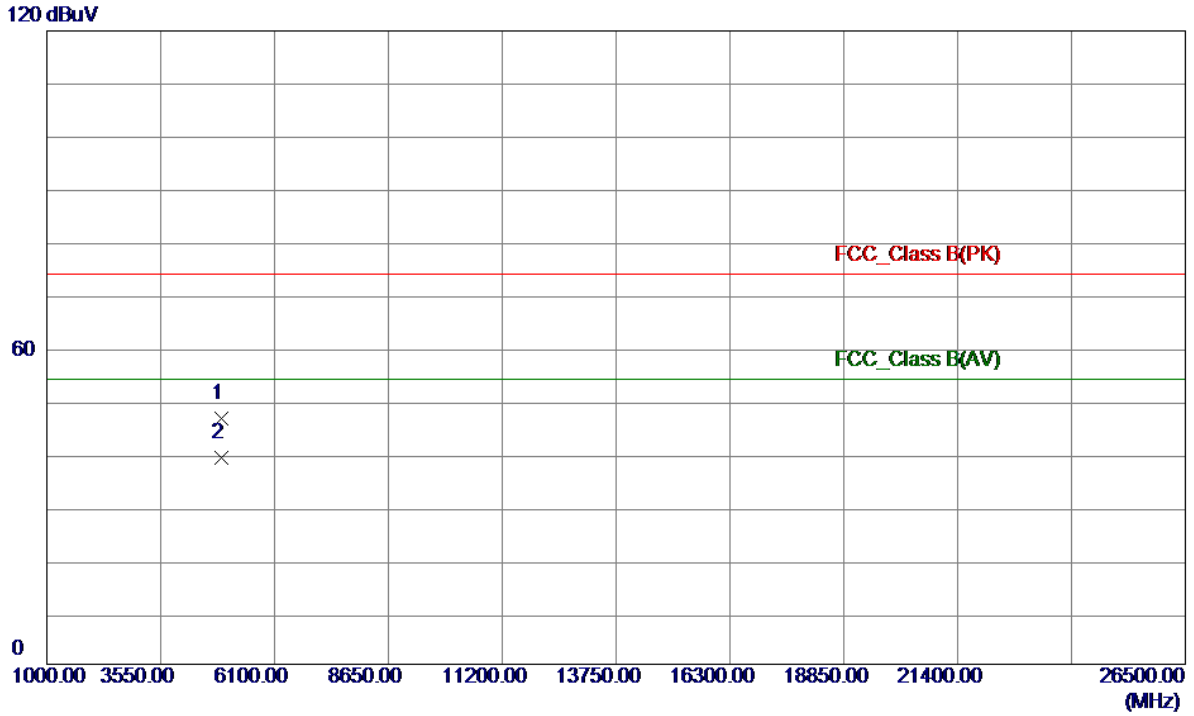

No.	Freq. MHz	Reading Level dBuV	Correct Factor dB	Measure ment dBuV	Limit dBuV	Margin dB	Detector	Comment
1	4924.0000	57.84	-11.32	46.52	74.00	-27.48	Peak	
2 *	4924.0000	50.42	-11.32	39.10	54.00	-14.90	AVG	

Orthogonal Axis :	X
Test Mode :	TX B MODE 2437MHz

Horizontal

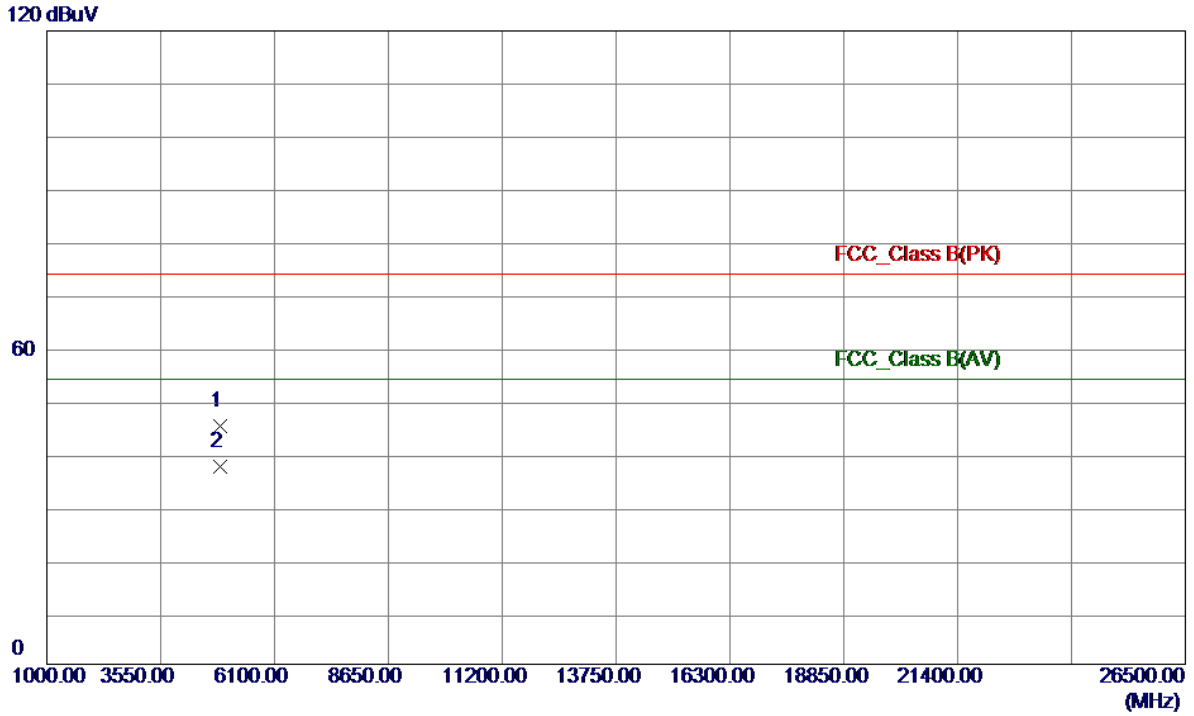

No.	Freq. MHz	Reading Level dBuV	Correct Factor dB	Measure ment dBuV	Limit dBuV	Margin dB	Detector	Comment
1	4874.0000	56.52	-11.39	45.13	74.00	-28.87	Peak	
2 *	4874.0000	48.73	-11.39	37.34	54.00	-16.66	AVG	

Orthogonal Axis :	X
Test Mode :	TX B MODE 2462MHz

Vertical

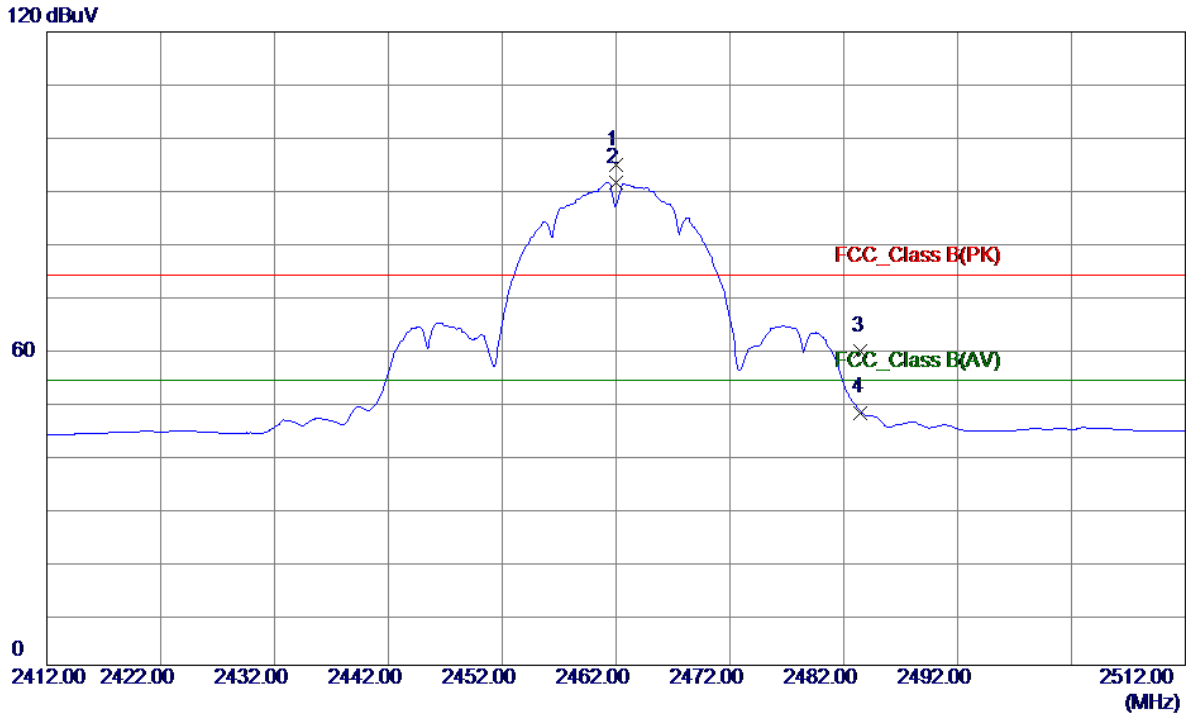

No.	Freq. MHz	Reading Level dBuV	Correct Factor dB	Measure ment dBuV	Limit dBuV	Margin dB	Detector	Comment
1	2462.0000	63.66	31.23	94.89	74.00	20.89	Peak	No Limit
2 *	2462.0000	60.25	31.23	91.48	54.00	37.48	AVG	No Limit
3	2483.5000	28.13	31.31	59.44	74.00	-14.56	Peak	
4	2483.5000	16.57	31.31	47.88	54.00	-6.12	AVG	

Orthogonal Axis :	X
Test Mode :	TX B MODE 2462MHz

Vertical

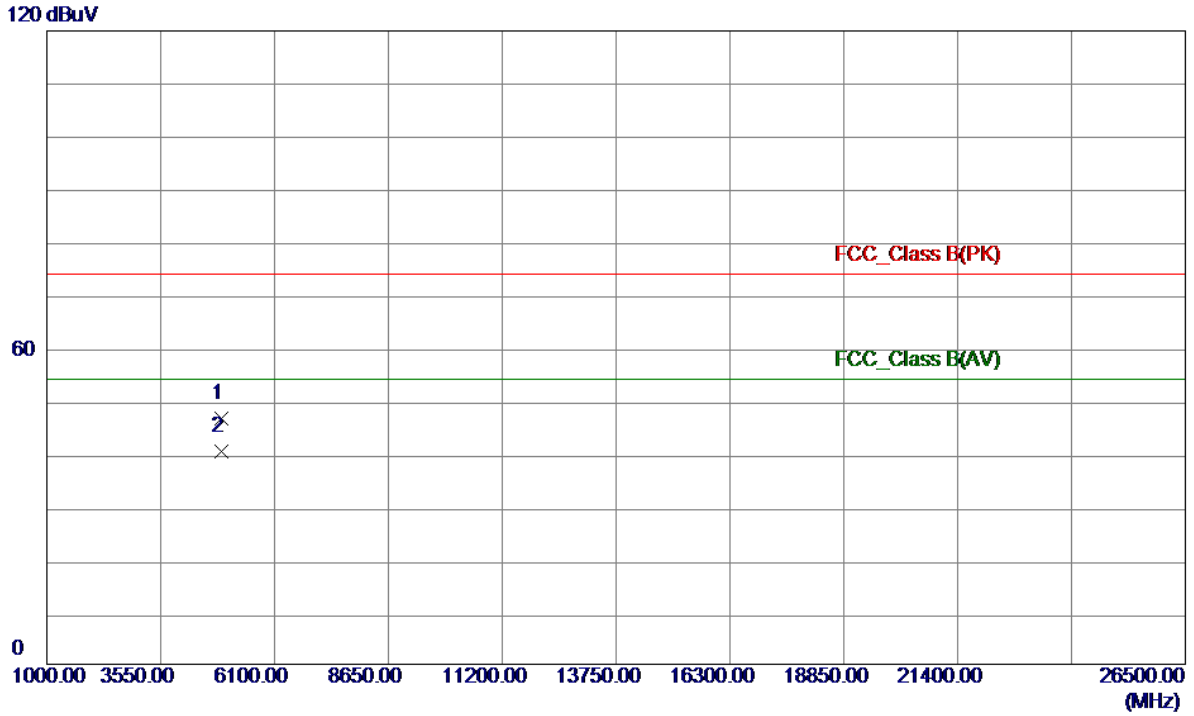

No.	Freq. MHz	Reading Level dBuV	Correct Factor dB	Measure ment dBuV	Limit dBuV	Margin dB	Detector	Comment
1	4924.0000	57.93	-11.32	46.61	74.00	-27.39	Peak	
2 *	4924.0000	51.56	-11.32	40.24	54.00	-13.76	AVG	

Orthogonal Axis :	X
Test Mode :	TX B MODE 2462MHz

Horizontal

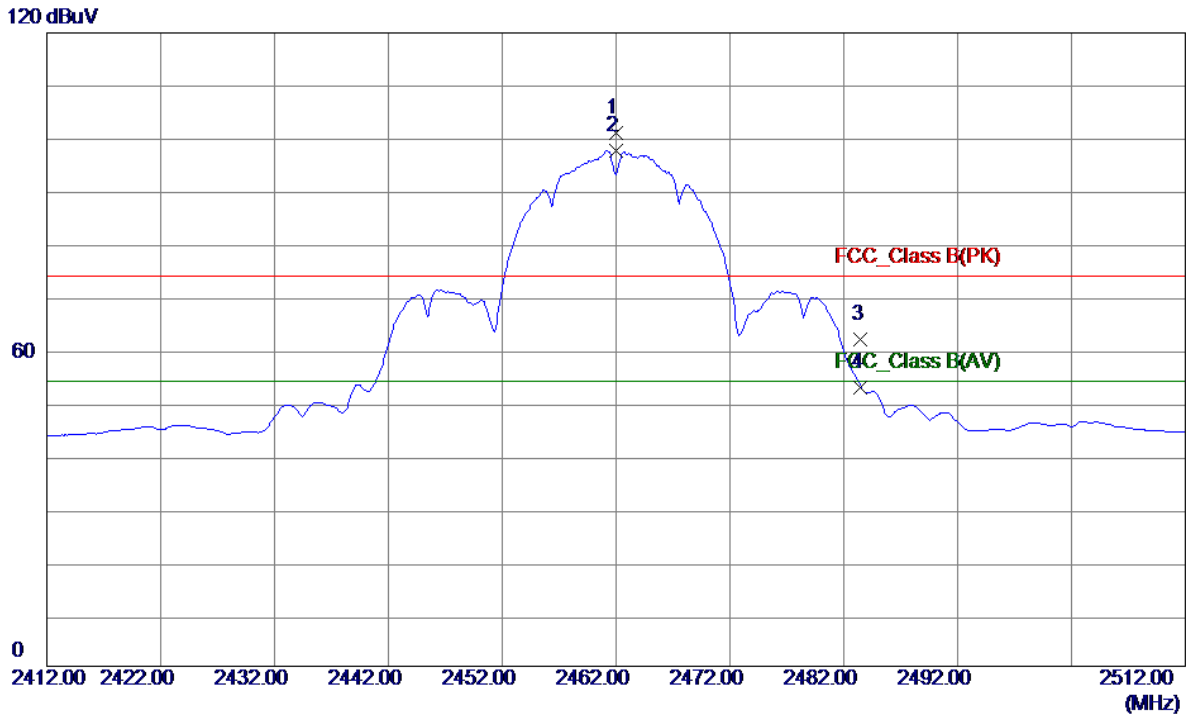

No.	Freq. MHz	Reading Level dBuV	Correct Factor dB	Measure ment dBuV	Limit dBuV	Margin dB	Detector	Comment
1	2462.0000	69.85	31.23	101.08	74.00	27.08	Peak	No Limit
2 *	2462.0000	66.49	31.23	97.72	54.00	43.72	AVG	No Limit
3	2483.5000	30.71	31.31	62.02	74.00	-11.98	Peak	
4	2483.5000	21.60	31.31	52.91	54.00	-1.09	AVG	

Orthogonal Axis :	X
Test Mode :	TX B MODE 2462MHz

Horizontal

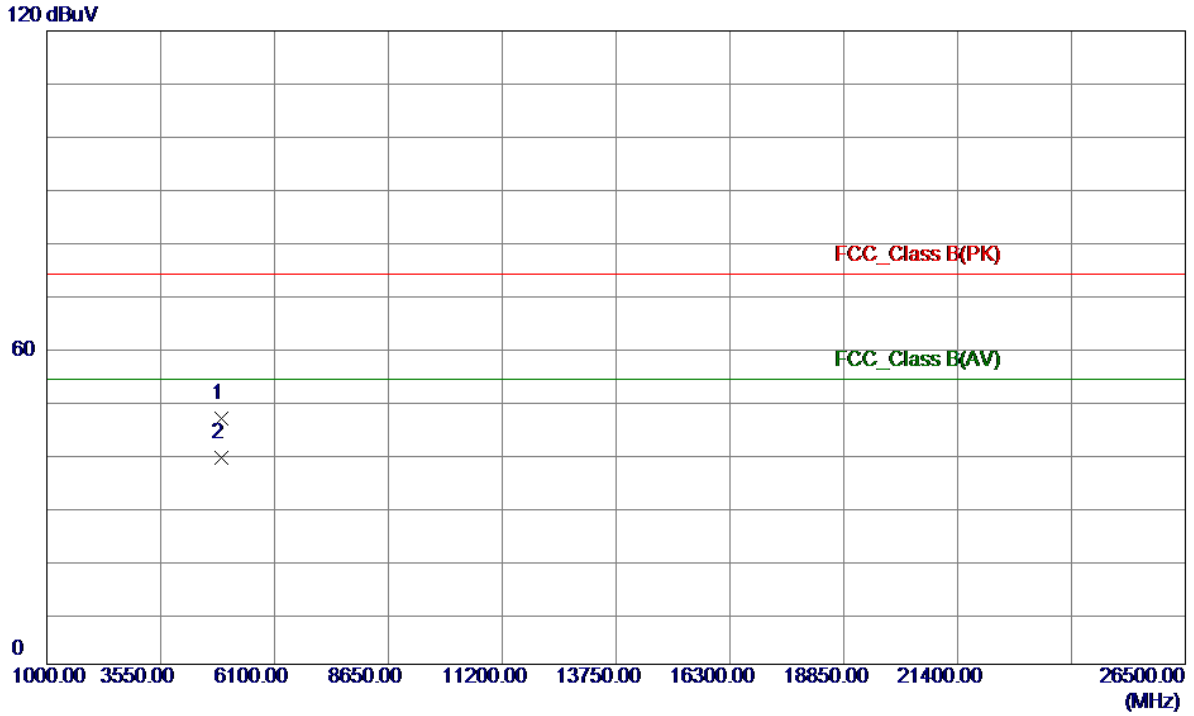

No.	Freq. MHz	Reading Level dBuV	Correct Factor dB	Measure ment dBuV	Limit dBuV	Margin dB	Detector	Comment
1	4924.0000	57.84	-11.32	46.52	74.00	-27.48	Peak	
2 *	4924.0000	50.42	-11.32	39.10	54.00	-14.90	AVG	

Orthogonal Axis :	X
Test Mode :	TX G MODE 2412MHz

Vertical

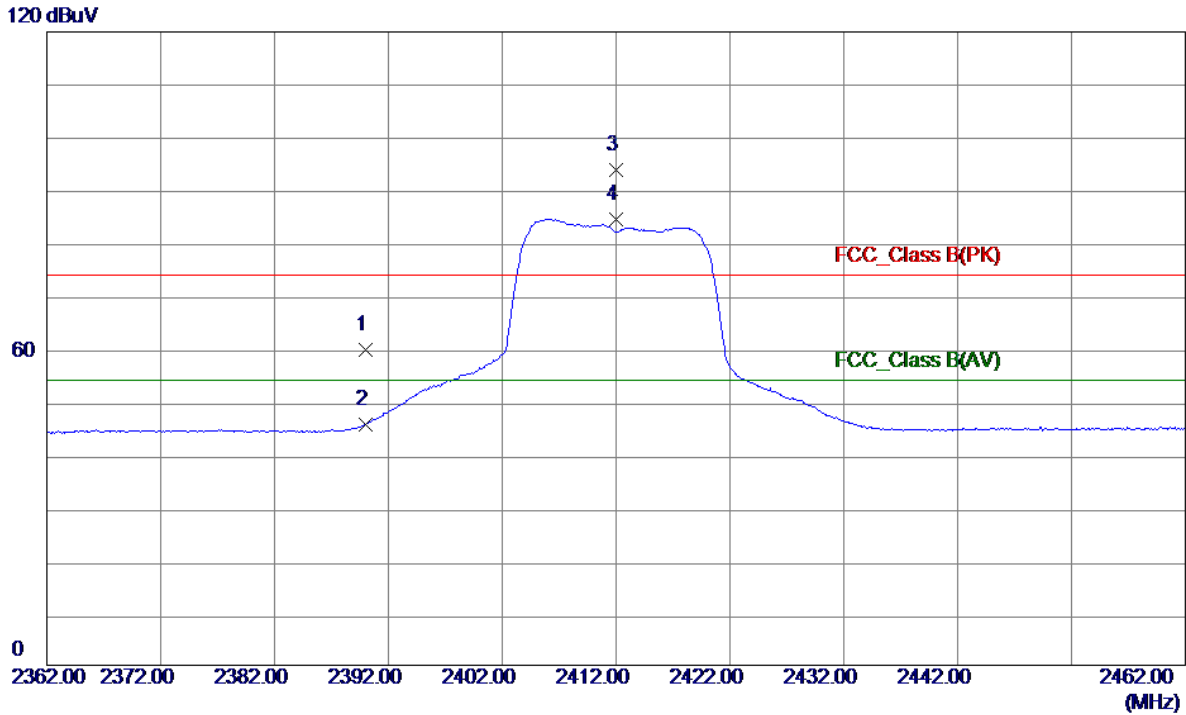

No.	Freq. MHz	Reading Level dBuV	Correct Factor dB	Measure ment dBuV	Limit dBuV	Margin dB	Detector	Comment
1	2390.0000	28.83	30.97	59.80	74.00	-14.20	Peak	
2	2390.0000	14.67	30.97	45.64	54.00	-8.36	AVG	
3	2412.0000	62.68	31.05	93.73	74.00	19.73	Peak	No Limit
4 *	2412.0000	53.42	31.05	84.47	54.00	30.47	AVG	No Limit

Orthogonal Axis :	X
Test Mode :	TX G MODE 2412MHz

Vertical

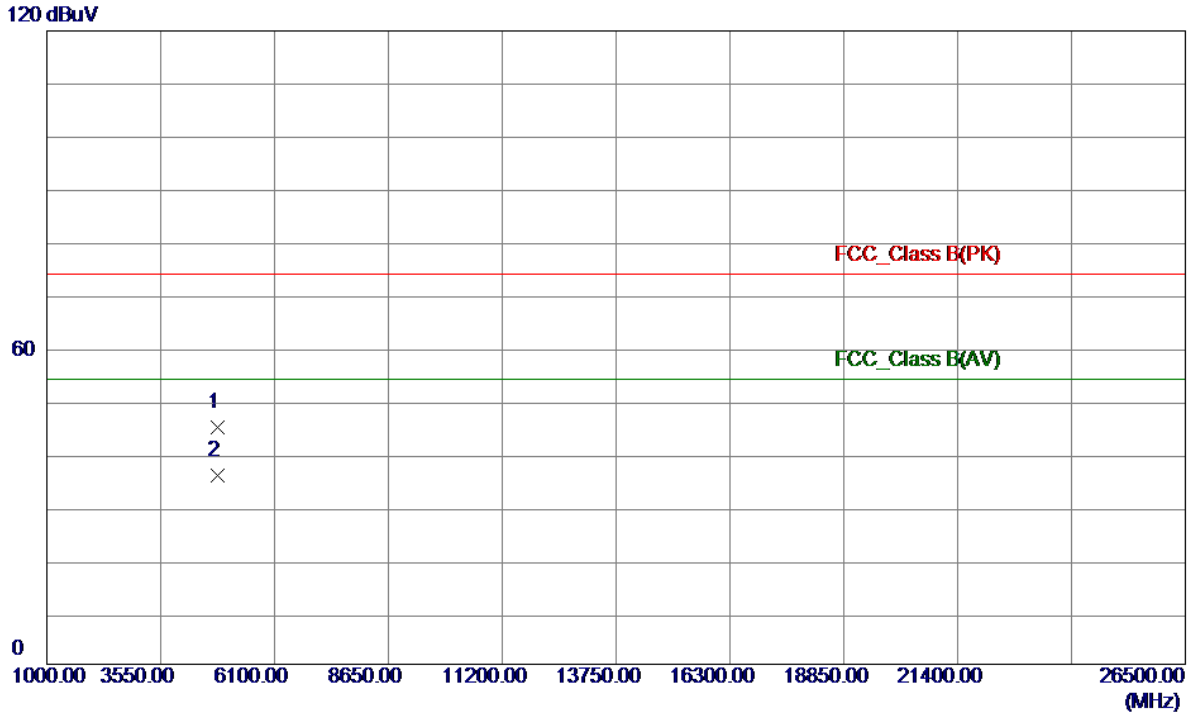

No.	Freq. MHz	Reading Level dBuV	Correct Factor dB	Measure ment dBuV	Limit dBuV	Margin dB	Detector	Comment
1	4824.0000	56.34	-11.47	44.87	74.00	-29.13	Peak	
2 *	4824.0000	47.12	-11.47	35.65	54.00	-18.35	AVG	

Orthogonal Axis :	X
Test Mode :	TX G MODE 2412MHz

Horizontal

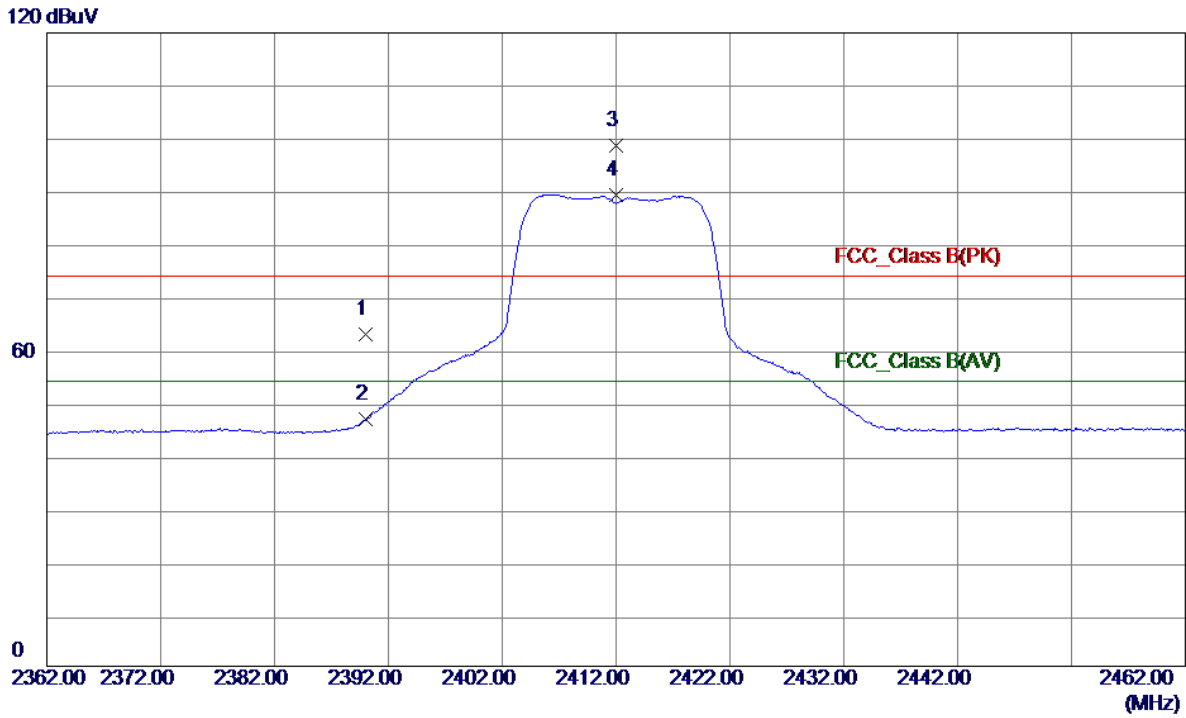

No.	Freq. MHz	Reading Level dBuV	Correct Factor dB	Measure ment dBuV	Limit dBuV	Margin dB	Detector	Comment
1	2389.9720	31.93	30.96	62.89	74.00	-11.11	Peak	
2	2389.9720	15.93	30.96	46.89	54.00	-7.11	AVG	
3	2412.0000	67.63	31.05	98.68	74.00	24.68	Peak	No Limit
4 *	2412.0000	58.32	31.05	89.37	54.00	35.37	AVG	No Limit

Orthogonal Axis :	X
Test Mode :	TX G MODE 2412MHz

Horizontal

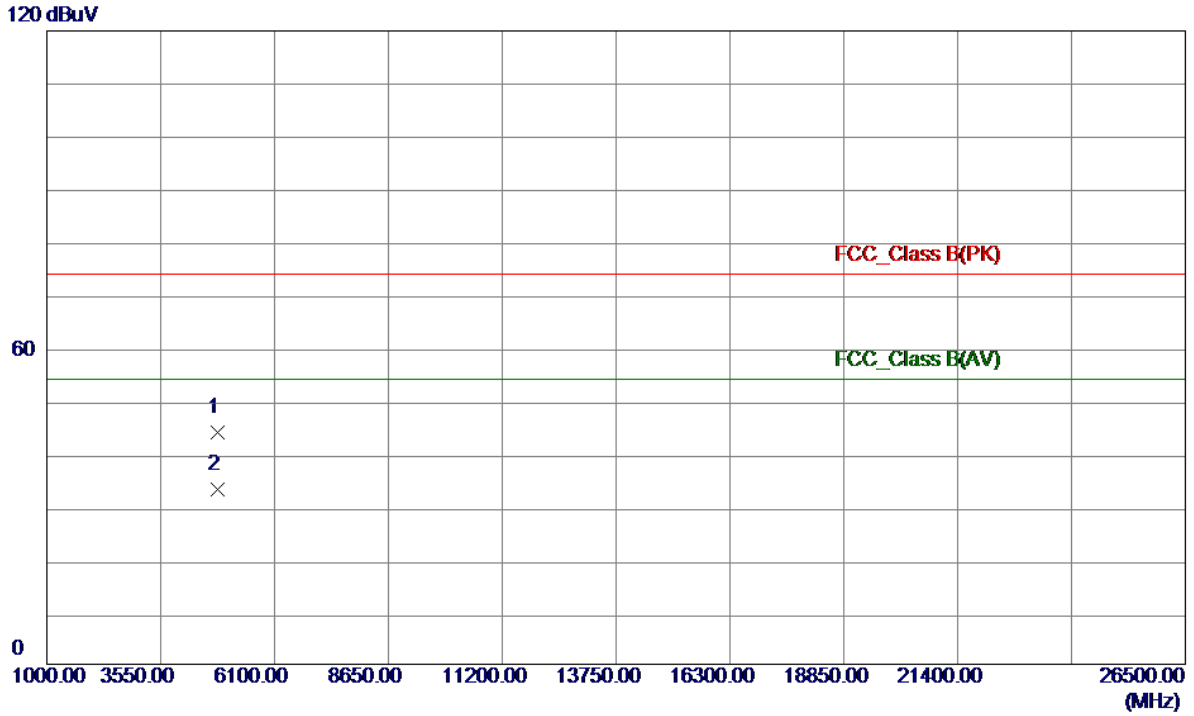

No.	Freq. MHz	Reading Level dBuV	Correct Factor dB	Measure ment dBuV	Limit dBuV	Margin dB	Detector	Comment
1	4824.0000	55.46	-11.47	43.99	74.00	-30.01	Peak	
2 *	4824.0000	44.52	-11.47	33.05	54.00	-20.95	AVG	

Orthogonal Axis :	X
Test Mode :	TX G MODE 2437MHz

Vertical

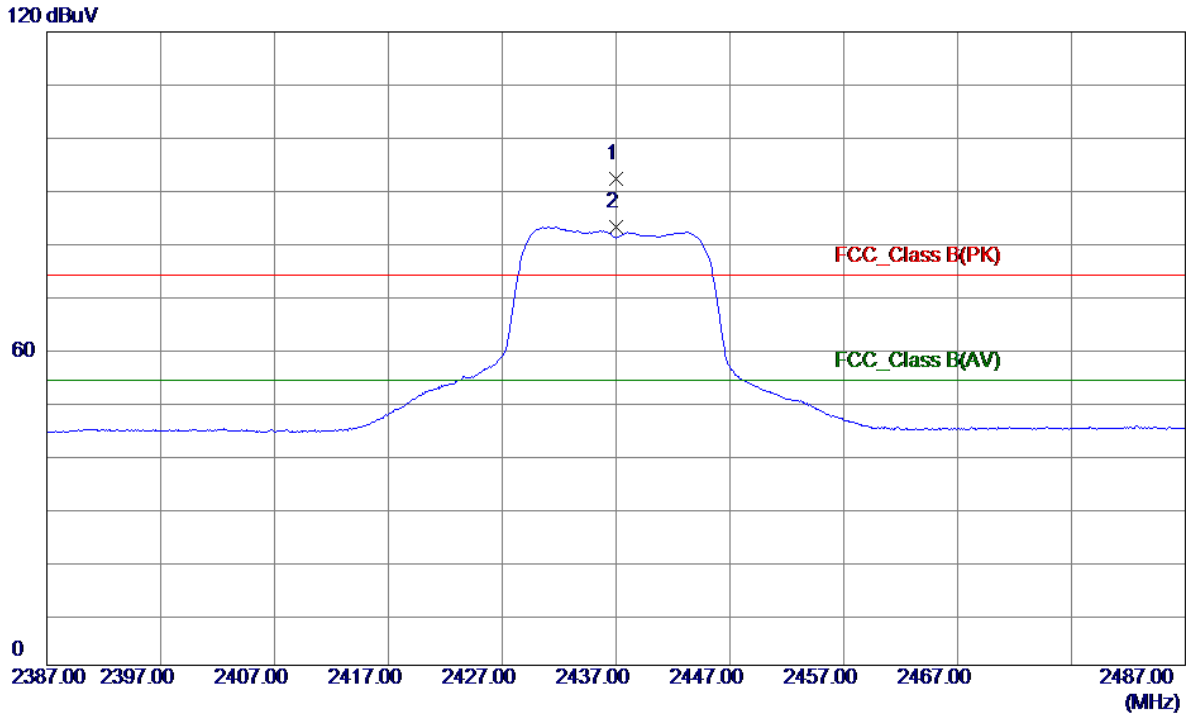

No.	Freq. MHz	Reading Level dBuV	Correct Factor dB	Measure ment dBuV	Limit dBuV	Margin dB	Detector	Comment
1	2437.0000	61.05	31.14	92.19	74.00	18.19	Peak	No Limit
2 *	2437.0000	51.89	31.14	83.03	54.00	29.03	AVG	No Limit

Orthogonal Axis :	X
Test Mode :	TX G MODE 2437MHz

Vertical

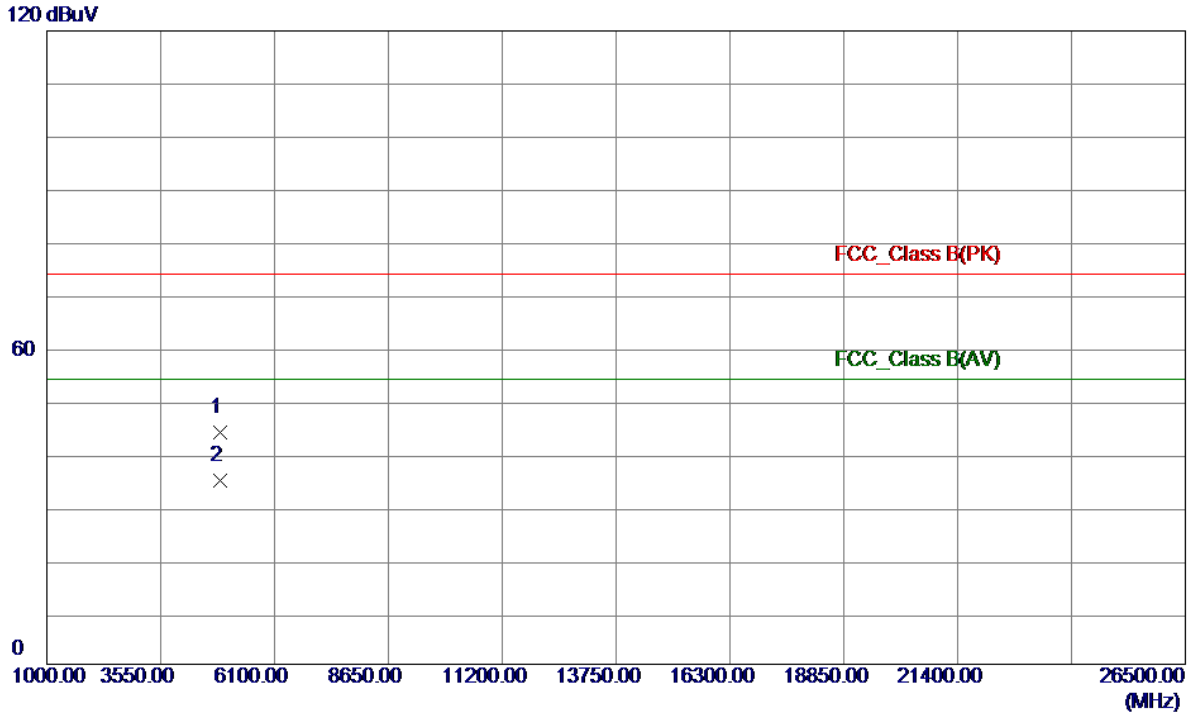

No.	Freq. MHz	Reading Level dBuV	Correct Factor dB	Measure ment dBuV	Limit dBuV	Margin dB	Detector	Comment
1	4874.0000	55.33	-11.39	43.94	74.00	-30.06	Peak	
2 *	4874.0000	46.13	-11.39	34.74	54.00	-19.26	AVG	

Orthogonal Axis :	X
Test Mode :	TX G MODE 2437MHz

Horizontal

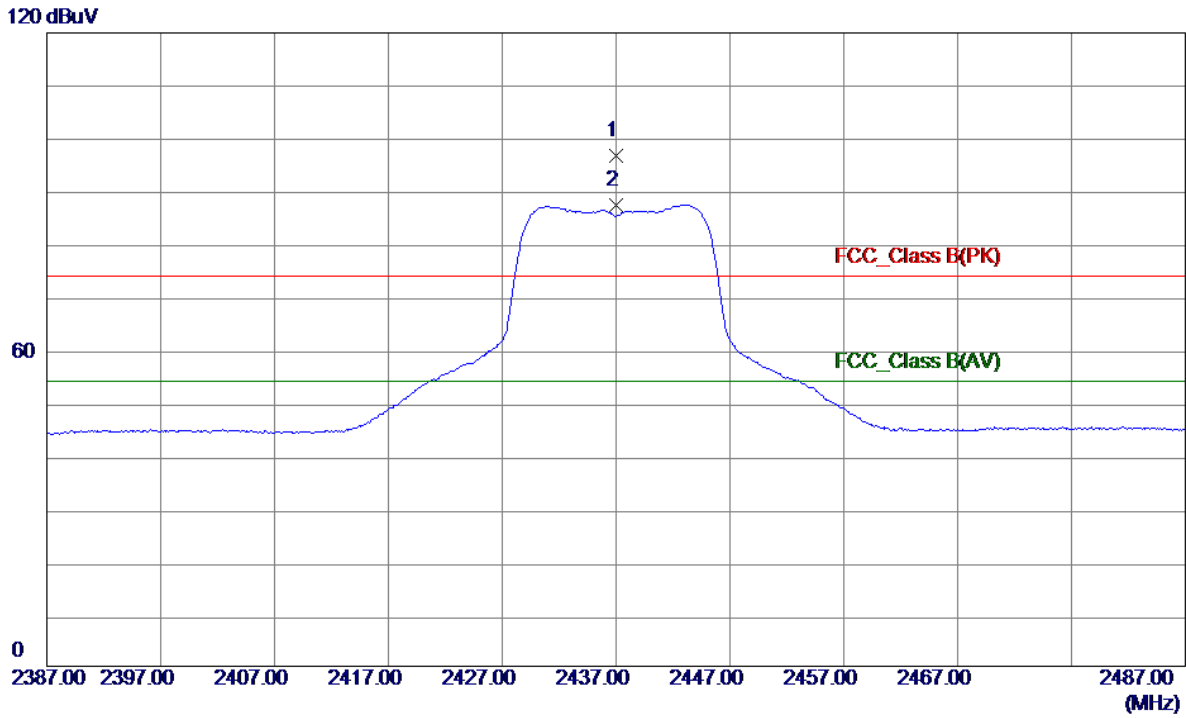

No.	Freq. MHz	Reading Level dBuV	Correct Factor dB	Measure ment dBuV	Limit dBuV	Margin dB	Detector	Comment
1	2437.0000	65.68	31.14	96.82	74.00	22.82	Peak	No Limit
2 *	2437.0000	56.26	31.14	87.40	54.00	33.40	AVG	No Limit

Orthogonal Axis :	X
Test Mode :	TX G MODE 2437MHz

Horizontal

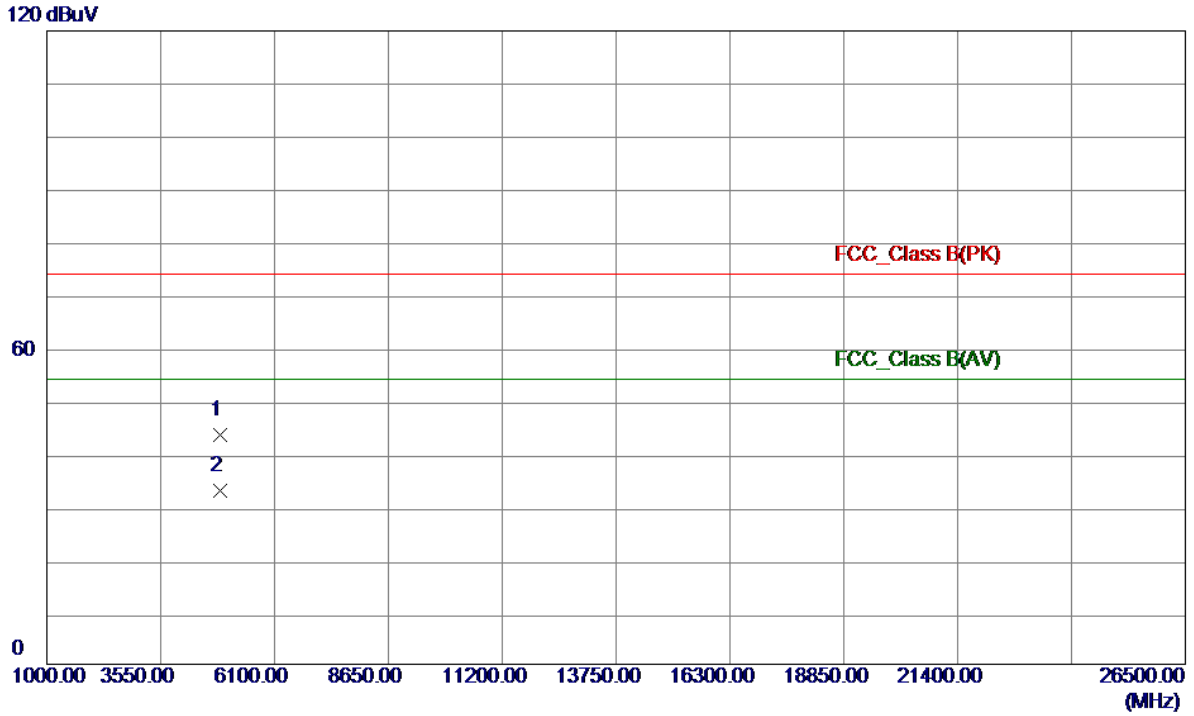

No.	Freq. MHz	Reading Level dBuV	Correct Factor dB	Measure ment dBuV	Limit dBuV	Margin dB	Detector	Comment
1	4874.0000	54.93	-11.39	43.54	74.00	-30.46	Peak	
2 *	4874.0000	44.24	-11.39	32.85	54.00	-21.15	AVG	

Orthogonal Axis :	X
Test Mode :	TX G MODE 2462MHz

Vertical

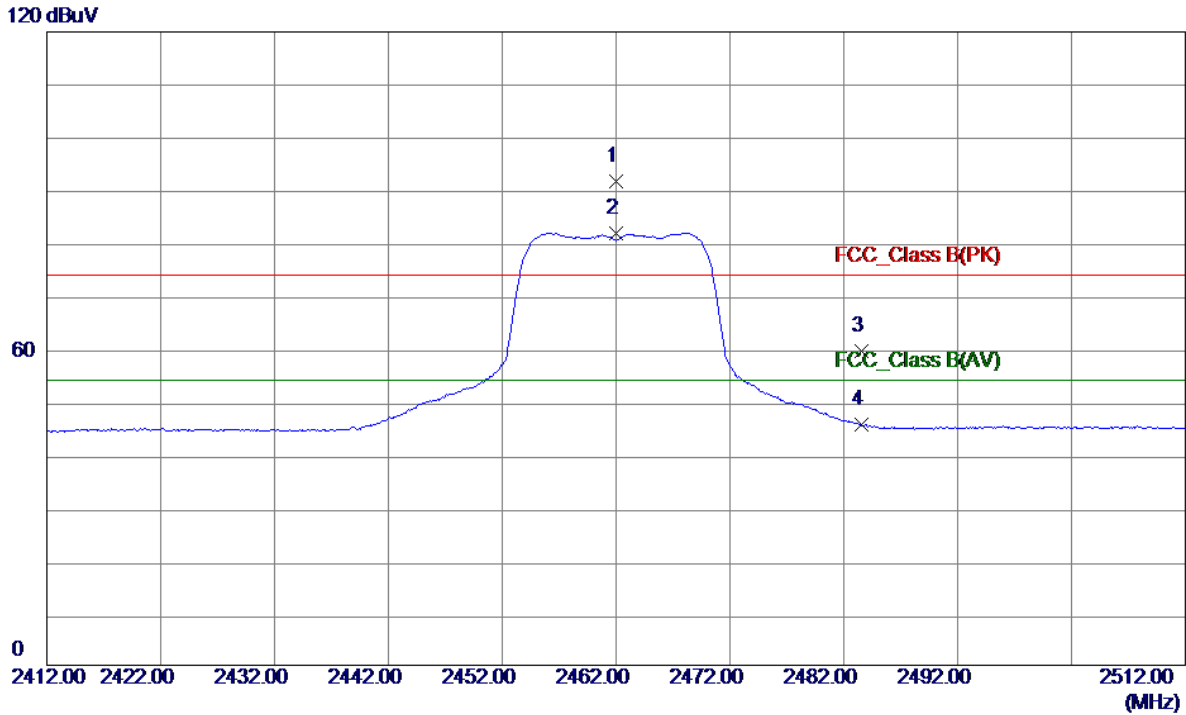

No.	Freq. MHz	Reading Level dBuV	Correct Factor dB	Measure ment dBuV	Limit dBuV	Margin dB	Detector	Comment
1	2462.0000	60.47	31.23	91.70	74.00	17.70	Peak	No Limit
2 *	2462.0000	50.63	31.23	81.86	54.00	27.86	AVG	No Limit
3	2483.5330	28.13	31.31	59.44	74.00	-14.56	Peak	
4	2483.5330	14.27	31.31	45.58	54.00	-8.42	AVG	

Orthogonal Axis :	X
Test Mode :	TX G MODE 2462MHz

Vertical

120 dBuV

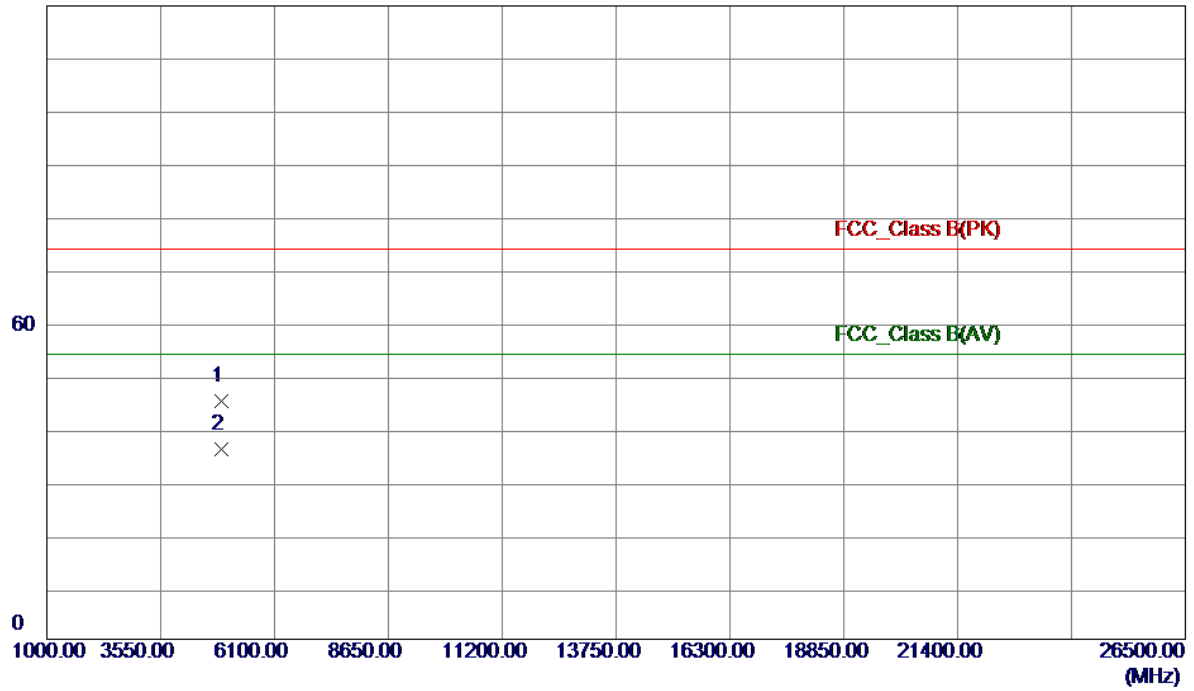

No.	Freq. MHz	Reading Level dBuV	Correct Factor dB	Measure ment dBuV	Limit dBuV	Margin dB	Detector	Comment
1	4924.0000	56.52	-11.32	45.20	74.00	-28.80	Peak	
2 *	4924.0000	47.29	-11.32	35.97	54.00	-18.03	AVG	

Orthogonal Axis :	X
Test Mode :	TX G MODE 2462MHz

Horizontal

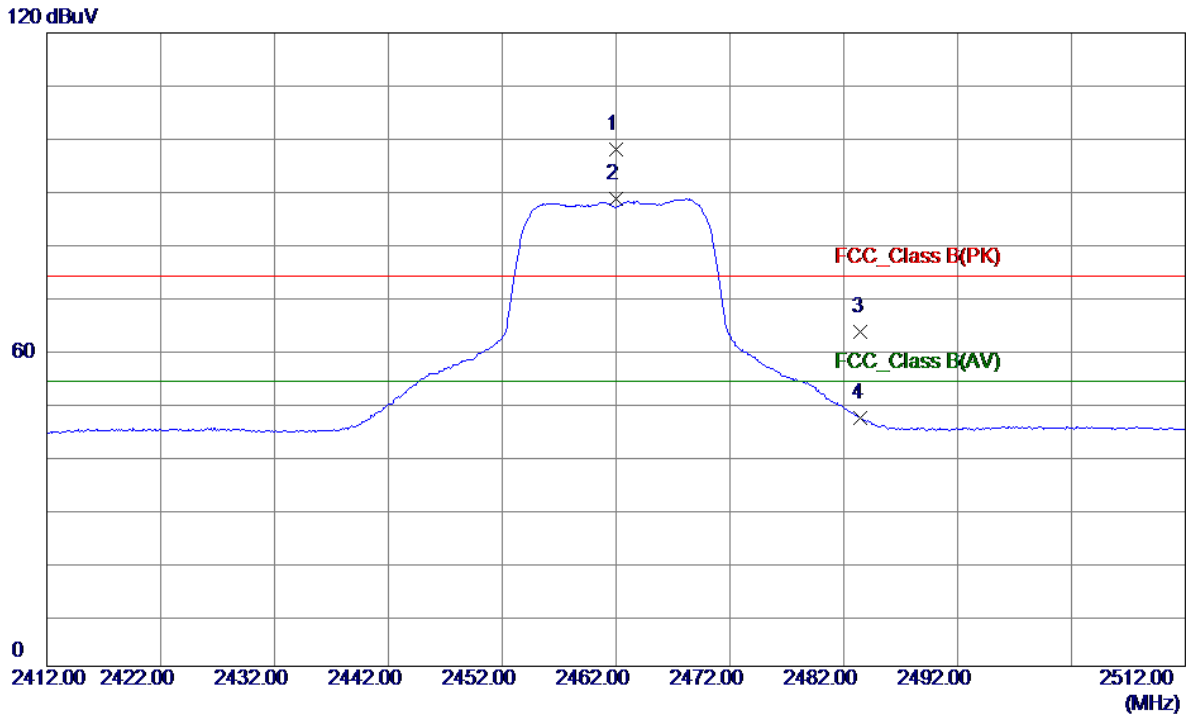

No.	Freq. MHz	Reading Level dBuV	Correct Factor dB	Measure ment dBuV	Limit dBuV	Margin dB	Detector	Comment
1	2462.0000	66.77	31.23	98.00	74.00	24.00	Peak	No Limit
2 *	2462.0000	57.30	31.23	88.53	54.00	34.53	AVG	No Limit
3	2483.5000	32.08	31.31	63.39	74.00	-10.61	Peak	
4	2483.5000	15.79	31.31	47.10	54.00	-6.90	AVG	

Orthogonal Axis :	X
Test Mode :	TX G MODE 2462MHz

Horizontal

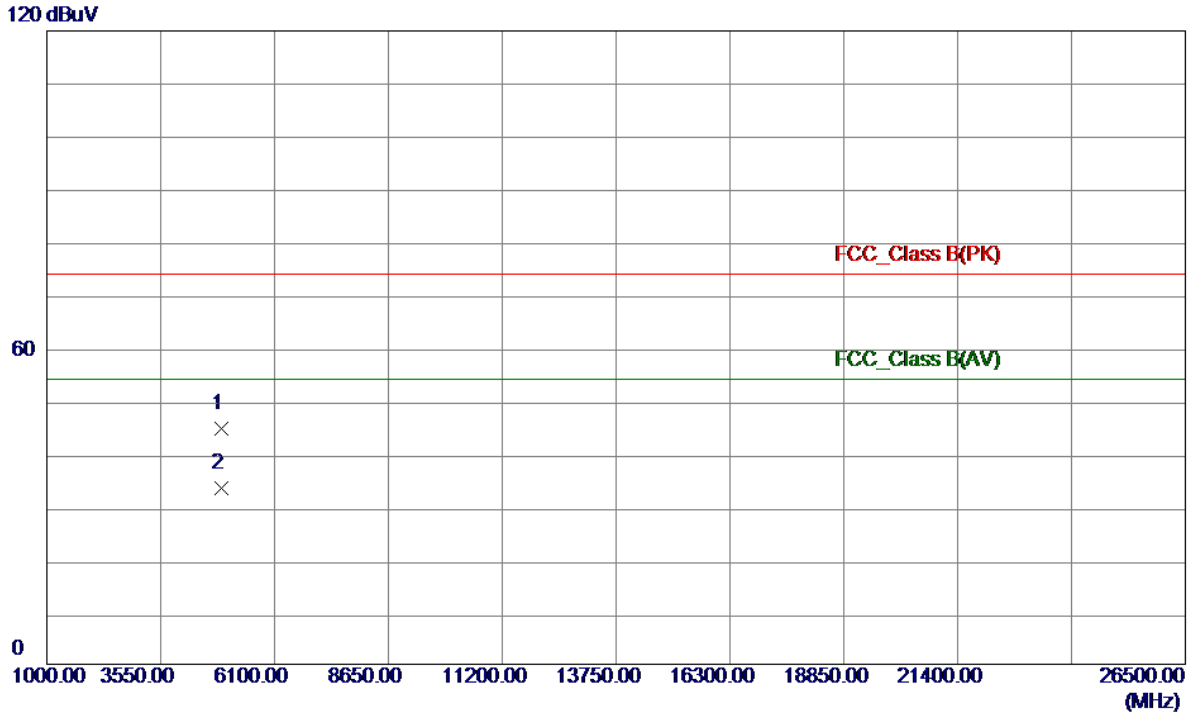

No.	Freq. MHz	Reading Level dBuV	Correct Factor dB	Measure ment dBuV	Limit dBuV	Margin dB	Detector	Comment
1	4924.0000	55.87	-11.32	44.55	74.00	-29.45	Peak	
2 *	4924.0000	44.60	-11.32	33.28	54.00	-20.72	AVG	

Orthogonal Axis :	X
Test Mode :	TX N-20M MODE 2412MHZ

Vertical

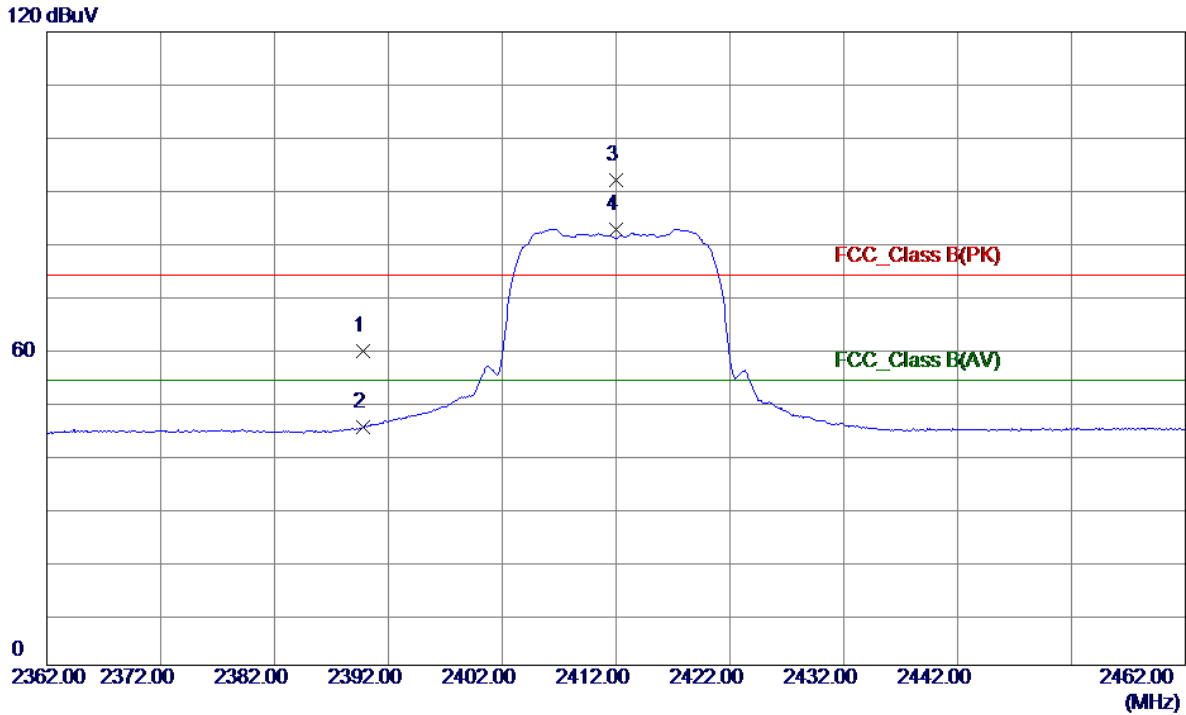

No.	Freq. MHz	Reading Level dBuV	Correct Factor dB	Measure ment dBuV	Limit dBuV	Margin dB	Detector	Comment
1	2389.8040	28.45	30.96	59.41	74.00	-14.59	Peak	
2	2389.8040	14.26	30.96	45.22	54.00	-8.78	AVG	
3	2412.0000	60.90	31.05	91.95	74.00	17.95	Peak	No Limit
4 *	2412.0000	51.61	31.05	82.66	54.00	28.66	AVG	No Limit

Orthogonal Axis :	X
Test Mode :	TX N-20M MODE 2412MHz

Vertical

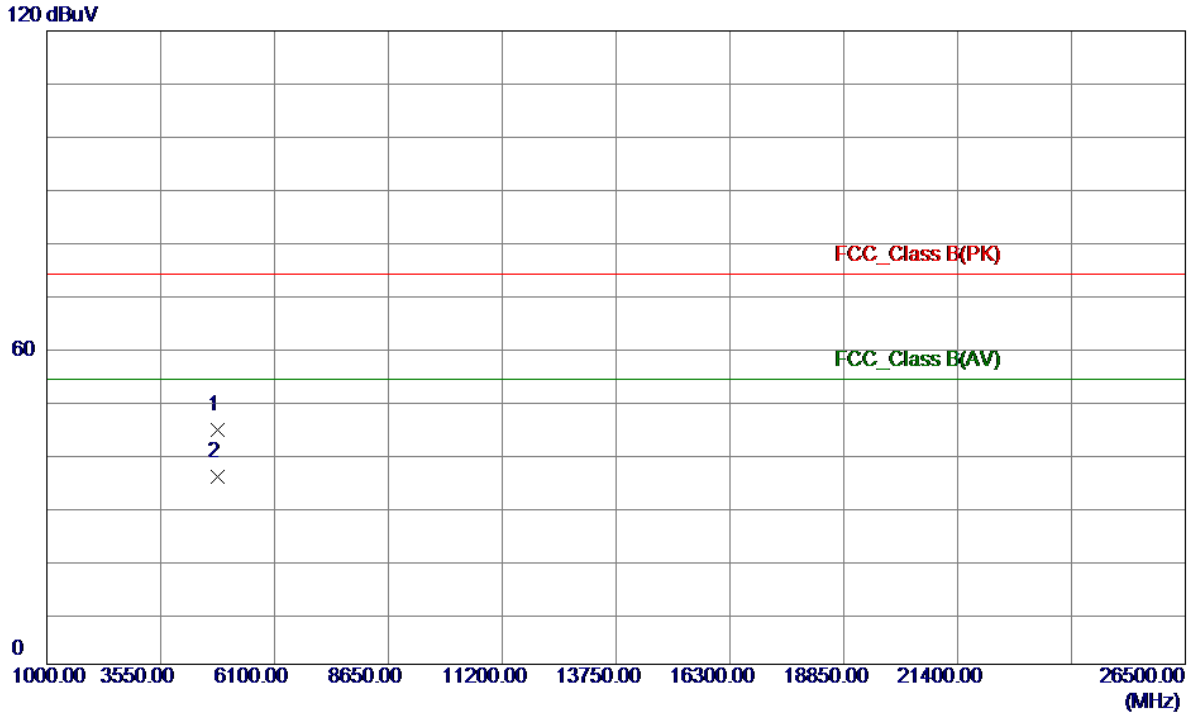

No.	Freq. MHz	Reading Level dBuV	Correct Factor dB	Measure ment dBuV	Limit dBuV	Margin dB	Detector	Comment
1	4824.0000	55.85	-11.47	44.38	74.00	-29.62	Peak	
2 *	4824.0000	47.07	-11.47	35.60	54.00	-18.40	AVG	

Orthogonal Axis :	X
Test Mode :	TX N-20M MODE 2412MHz

Horizontal

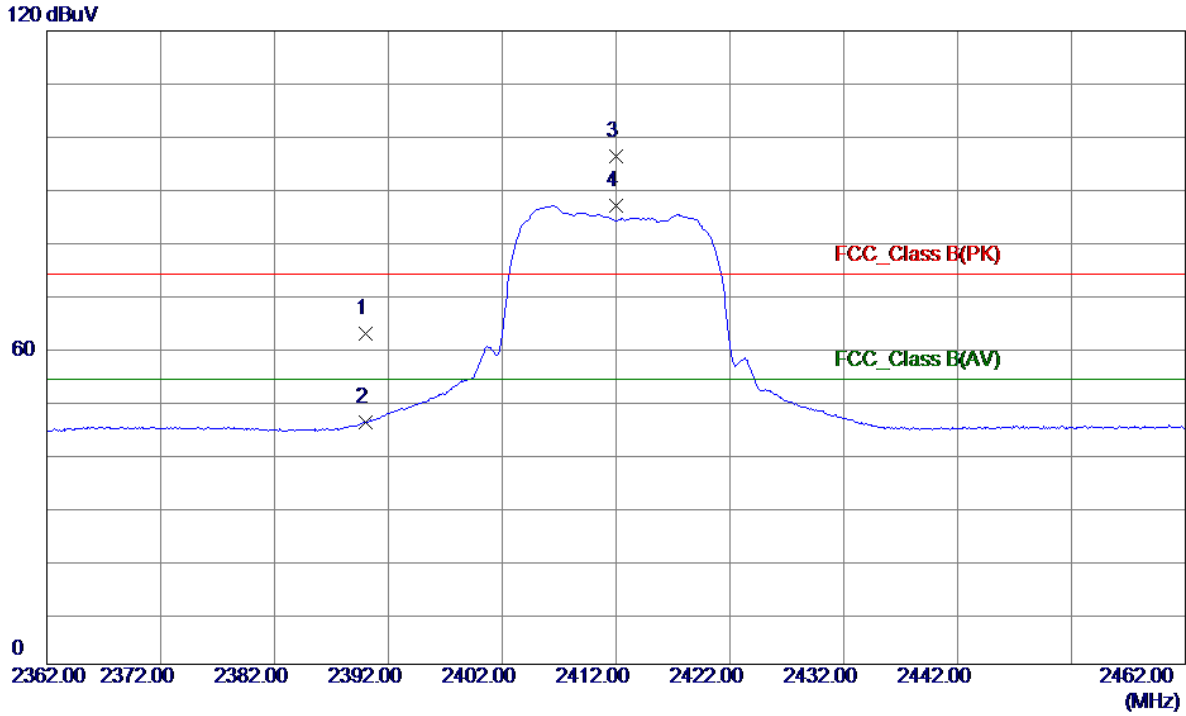

No.	Freq. MHz	Reading Level dBuV	Correct Factor dB	Measure ment dBuV	Limit dBuV	Margin dB	Detector	Comment
1	2389.9720	31.71	30.96	62.67	74.00	-11.33	Peak	
2	2389.9720	14.97	30.96	45.93	54.00	-8.07	AVG	
3	2412.0000	65.12	31.05	96.17	74.00	22.17	Peak	No Limit
4 *	2412.0000	55.80	31.05	86.85	54.00	32.85	AVG	No Limit

Orthogonal Axis :	X
Test Mode :	TX N-20M MODE 2412MHz

Horizontal

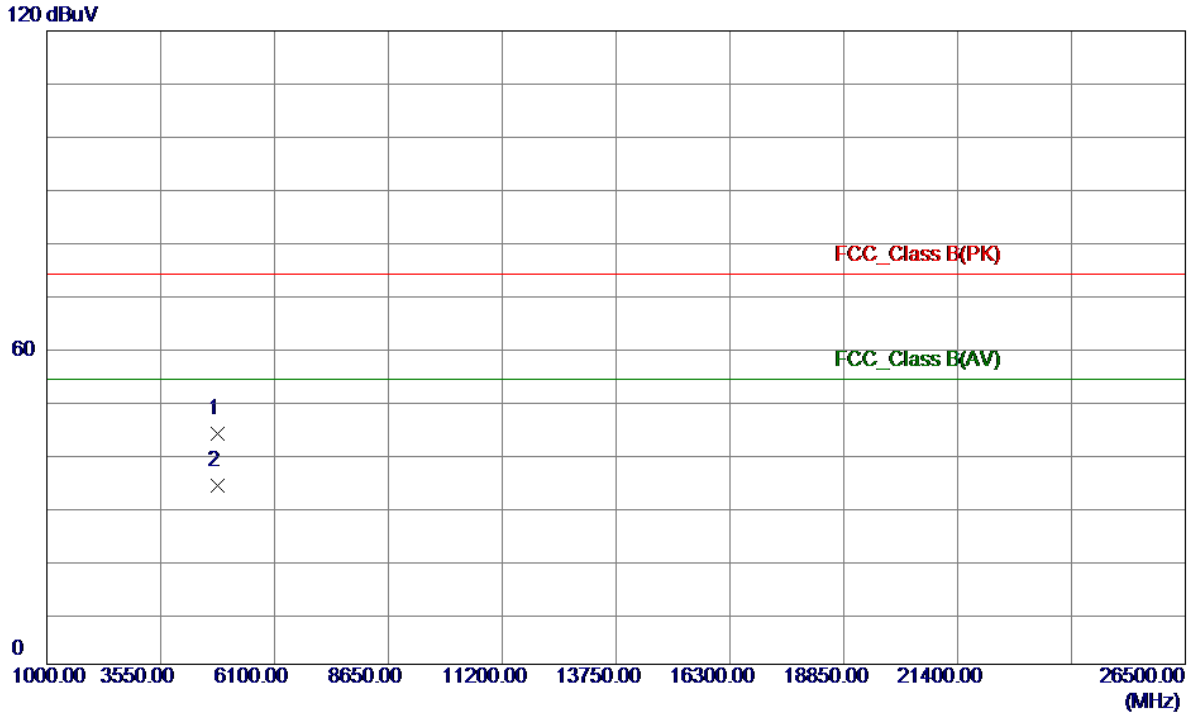

No.	Freq. MHz	Reading Level dBuV	Correct Factor dB	Measure ment dBuV	Limit dBuV	Margin dB	Detector	Comment
1	4824.0000	55.23	-11.47	43.76	74.00	-30.24	Peak	
2 *	4824.0000	45.29	-11.47	33.82	54.00	-20.18	AVG	

Orthogonal Axis :	X
Test Mode :	TX N-20M MODE 2437MHz

Vertical

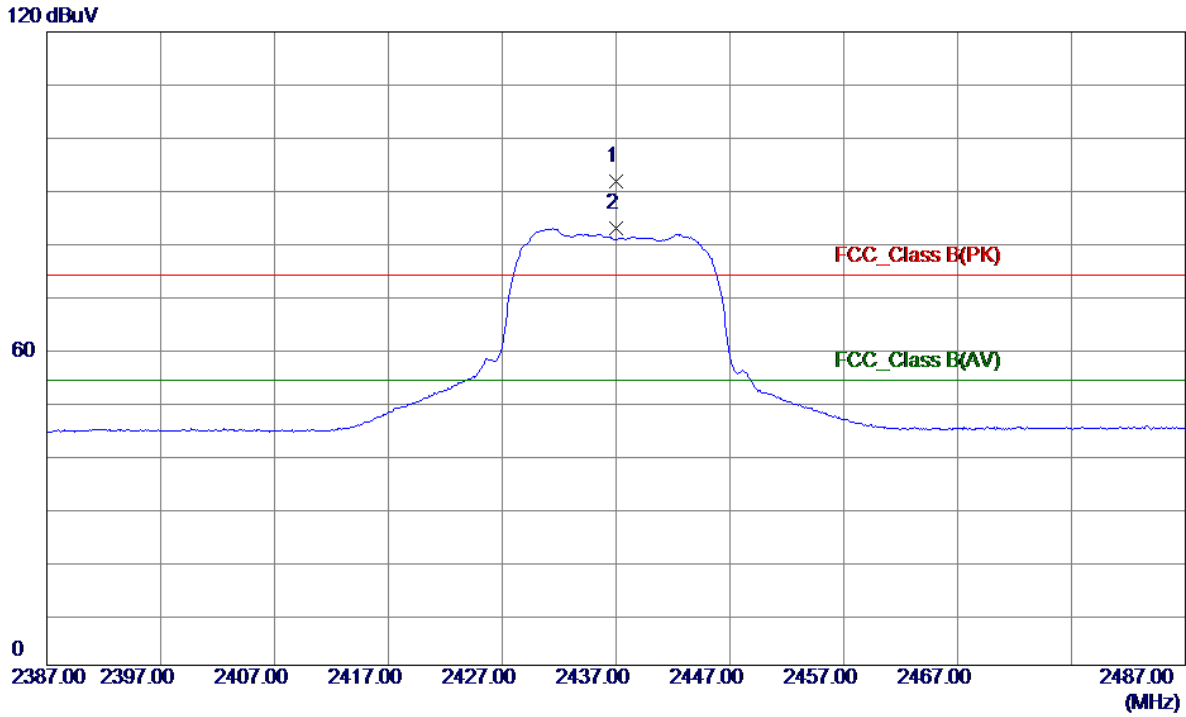

No.	Freq. MHz	Reading Level dBuV	Correct Factor dB	Measure ment dBuV	Limit dBuV	Margin dB	Detector	Comment
1	2437.0000	60.64	31.14	91.78	74.00	17.78	Peak	No Limit
2 *	2437.0000	51.60	31.14	82.74	54.00	28.74	AVG	No Limit

Orthogonal Axis :	X
Test Mode :	TX N-20M MODE 2437MHz

Vertical

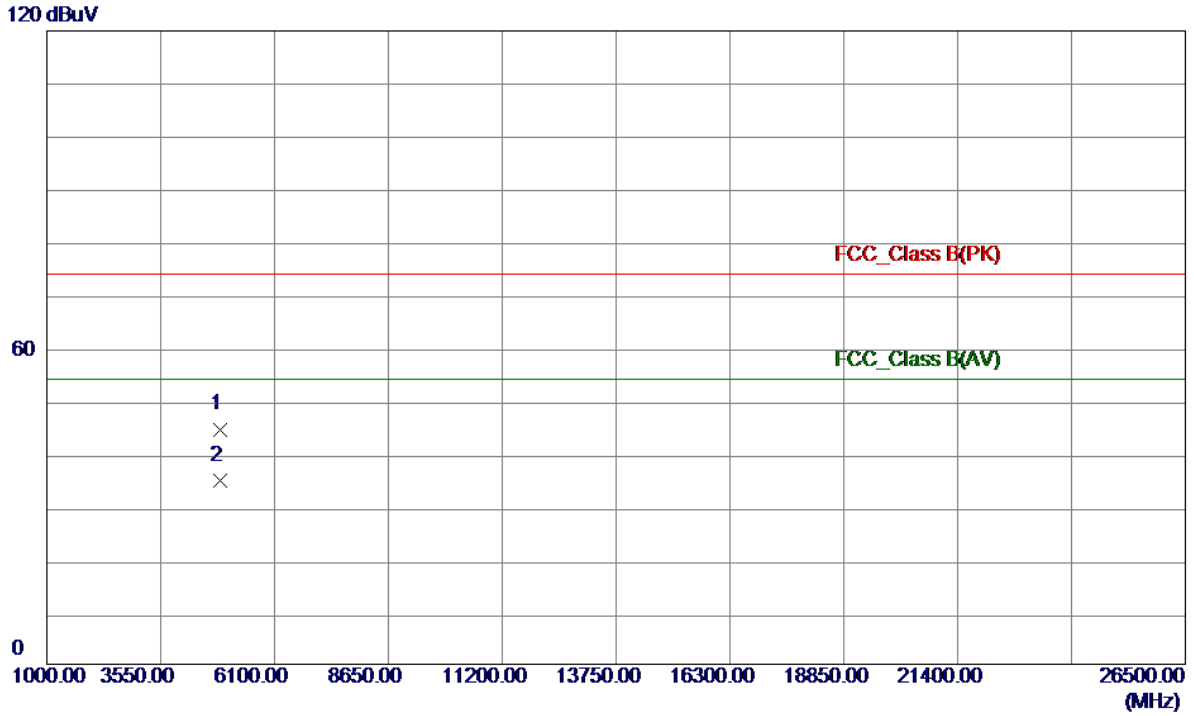

No.	Freq. MHz	Reading Level dBuV	Correct Factor dB	Measure ment dBuV	Limit dBuV	Margin dB	Detector	Comment
1	4874.0000	55.91	-11.39	44.52	74.00	-29.48	Peak	
2 *	4874.0000	46.23	-11.39	34.84	54.00	-19.16	AVG	

Orthogonal Axis :	X
Test Mode :	TX N-20M MODE 2437MHz

Horizontal

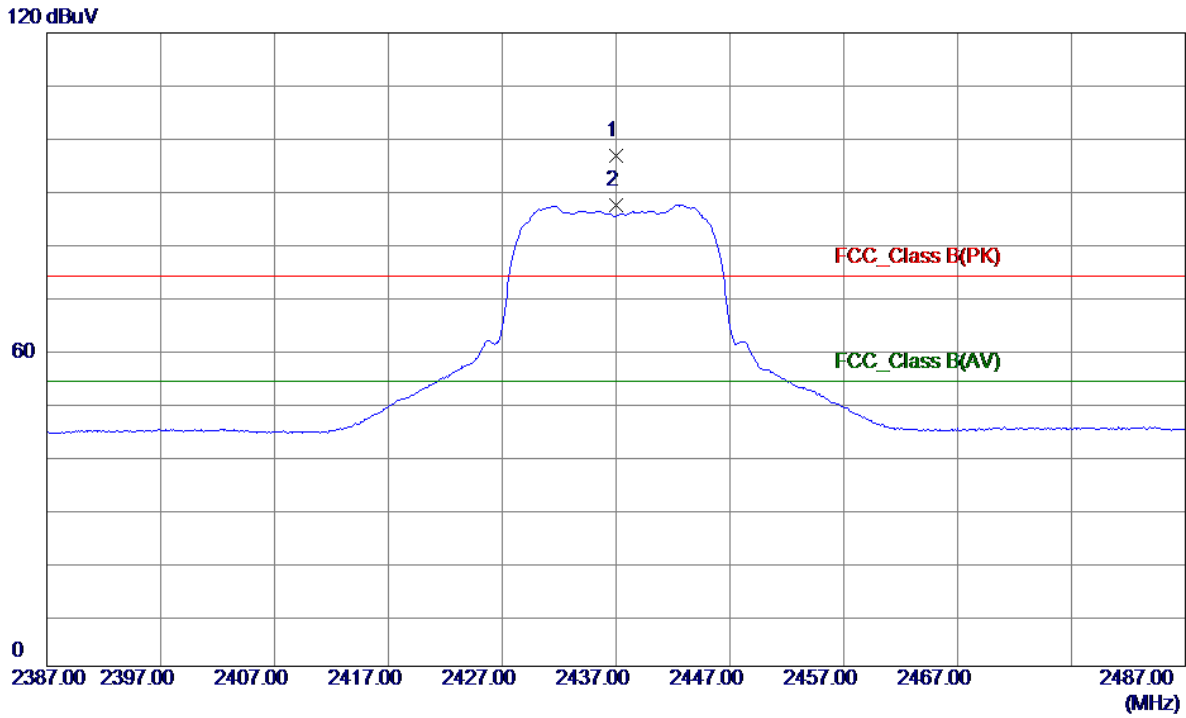

No.	Freq. MHz	Reading Level dBuV	Correct Factor dB	Measure ment dBuV	Limit dBuV	Margin dB	Detector	Comment
1	2437.0000	65.47	31.14	96.61	74.00	22.61	Peak	No Limit
2 *	2437.0000	56.21	31.14	87.35	54.00	33.35	AVG	No Limit

Orthogonal Axis :	X
Test Mode :	TX N-20M MODE 2437MHz

Horizontal

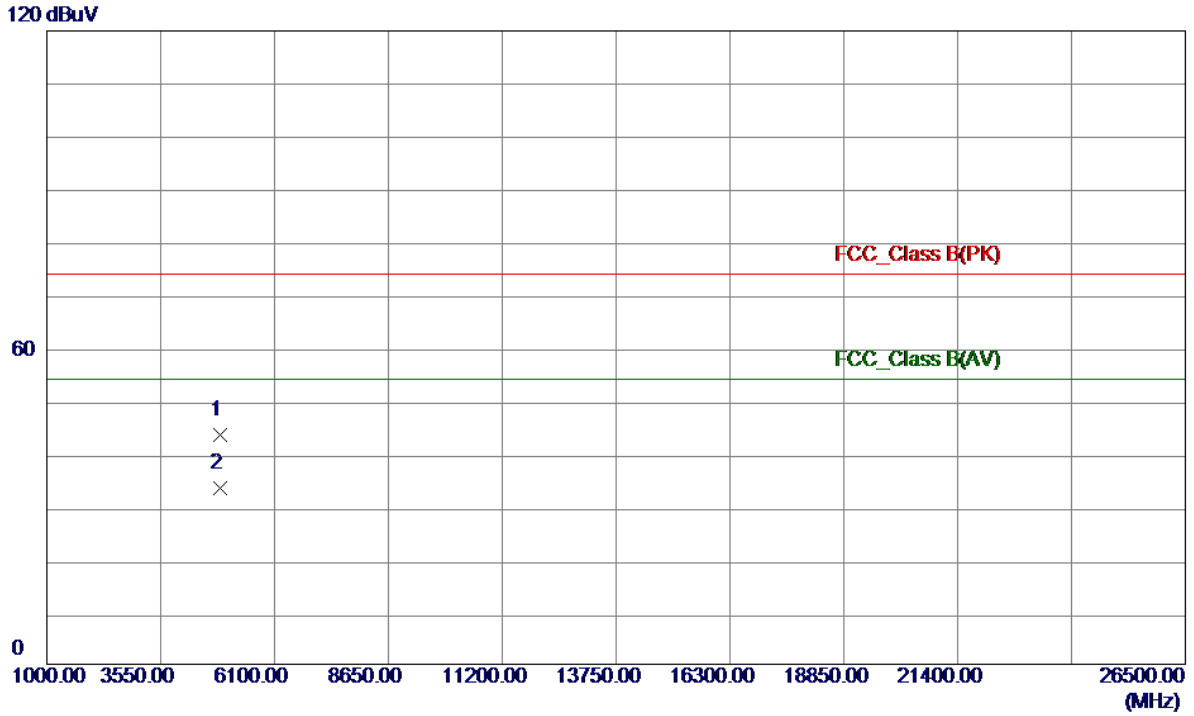

No.	Freq. MHz	Reading Level dBuV	Correct Factor dB	Measure ment dBuV	Limit dBuV	Margin dB	Detector	Comment
1	4874.0000	54.90	-11.39	43.51	74.00	-30.49	Peak	
2 *	4874.0000	44.80	-11.39	33.41	54.00	-20.59	AVG	

Orthogonal Axis :	X
Test Mode :	TX N-20M MODE 2462MHz

Vertical

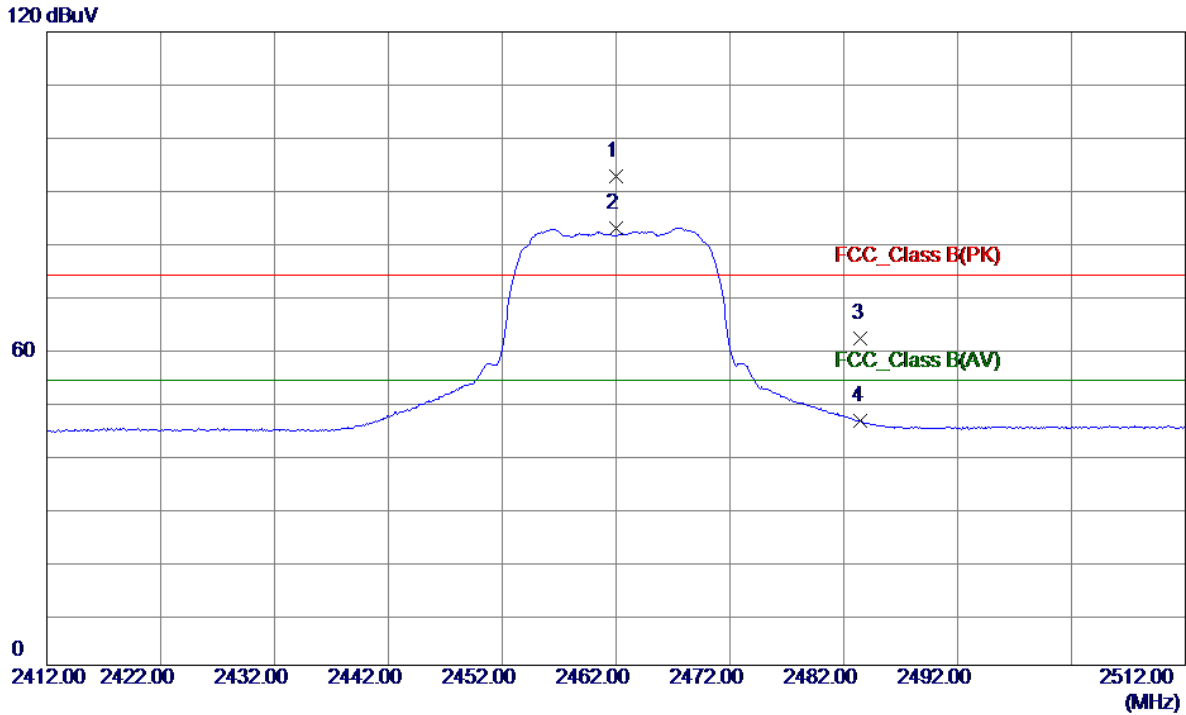

No.	Freq. MHz	Reading Level dBuV	Correct Factor dB	Measure ment dBuV	Limit dBuV	Margin dB	Detector	Comment
1	2462.0000	61.31	31.23	92.54	74.00	18.54	Peak	No Limit
2 *	2462.0000	51.59	31.23	82.82	54.00	28.82	AVG	No Limit
3	2483.5000	30.68	31.31	61.99	74.00	-12.01	Peak	
4	2483.5000	15.09	31.31	46.40	54.00	-7.60	AVG	

Orthogonal Axis :	X
Test Mode :	TX N-20M MODE 2462MHz

Vertical

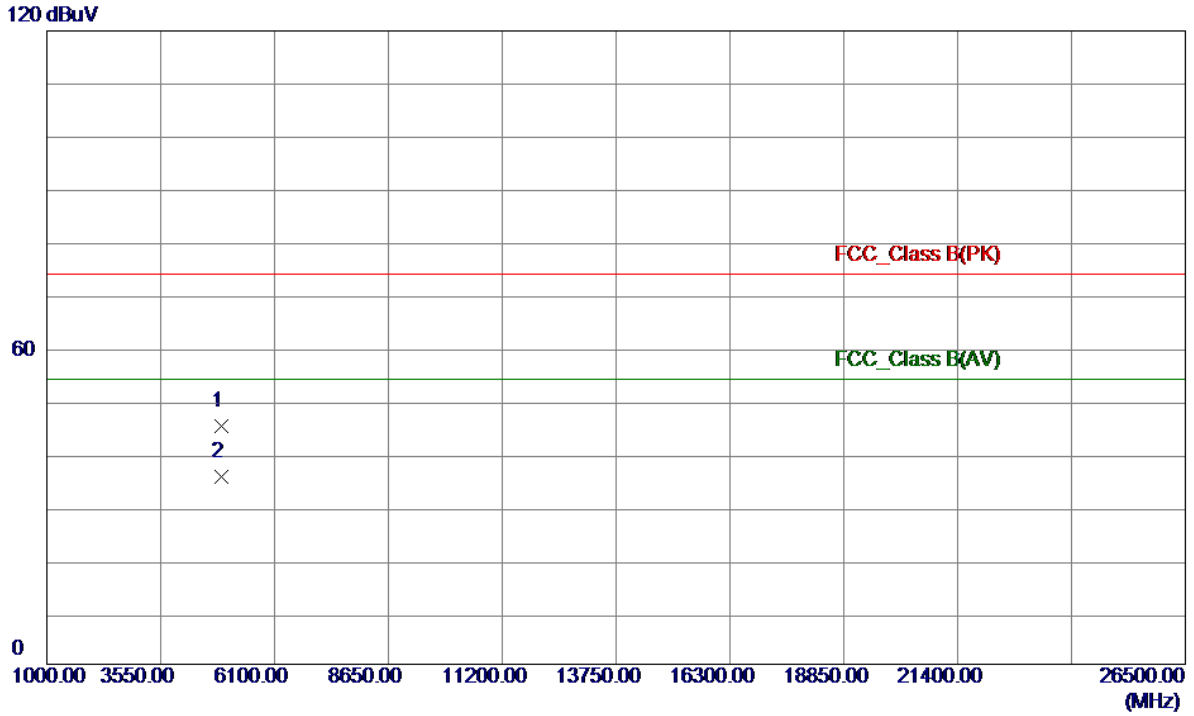

No.	Freq. MHz	Reading Level dBuV	Correct Factor dB	Measure ment dBuV	Limit dBuV	Margin dB	Detector	Comment
1	4924.0000	56.40	-11.32	45.08	74.00	-28.92	Peak	
2 *	4924.0000	46.83	-11.32	35.51	54.00	-18.49	AVG	

Orthogonal Axis :	X
Test Mode :	TX N-20M MODE 2462MHz

Horizontal

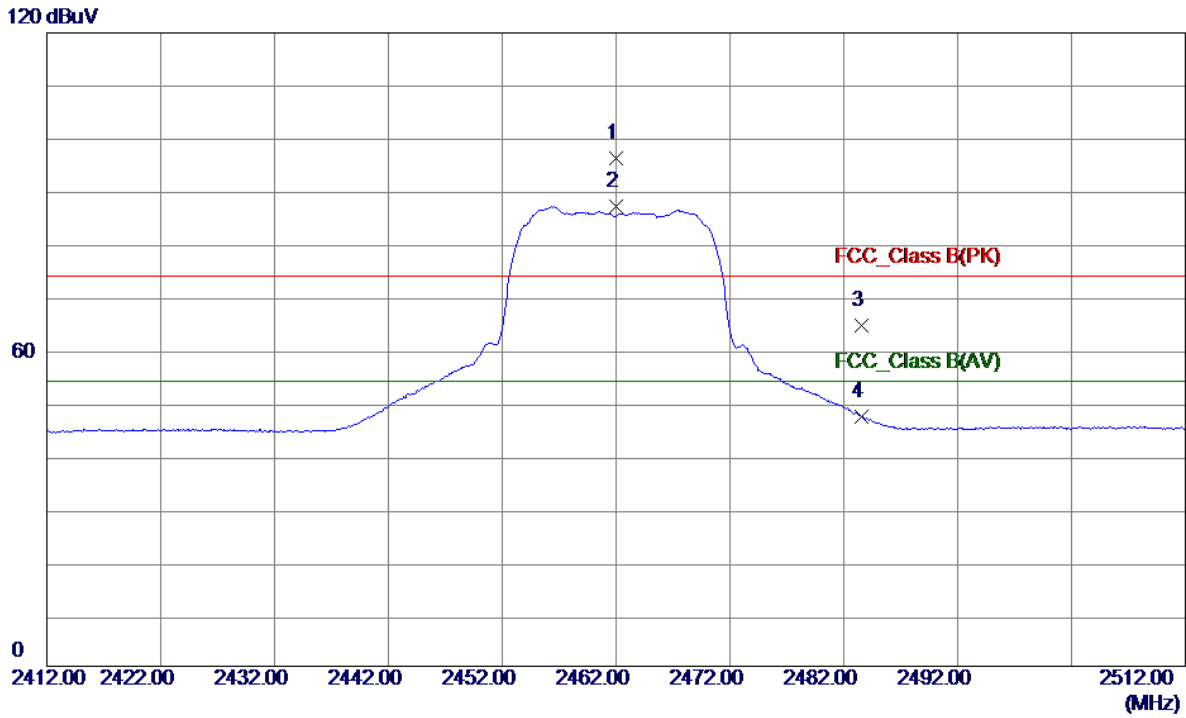

No.	Freq. MHz	Reading Level dBuV	Correct Factor dB	Measure ment dBuV	Limit dBuV	Margin dB	Detector	Comment
1	2462.0000	65.11	31.23	96.34	74.00	22.34	Peak	No Limit
2 *	2462.0000	55.84	31.23	87.07	54.00	33.07	AVG	No Limit
3	2483.5330	33.22	31.31	64.53	74.00	-9.47	Peak	
4	2483.5330	16.05	31.31	47.36	54.00	-6.64	AVG	

Orthogonal Axis :	X
Test Mode :	TX N-20M MODE 2462MHz

Horizontal

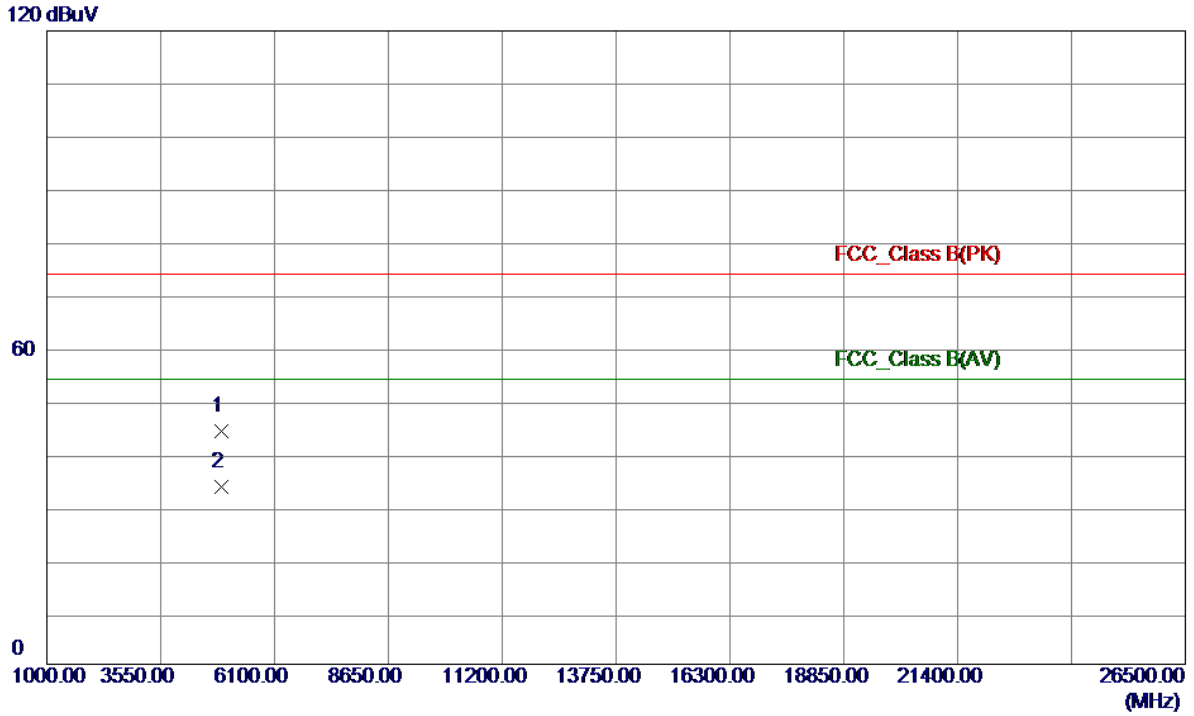

No.	Freq. MHz	Reading Level dBuV	Correct Factor dB	Measure ment dBuV	Limit dBuV	Margin dB	Detector	Comment
1	4924.0000	55.44	-11.32	44.12	74.00	-29.88	Peak	
2 *	4924.0000	45.01	-11.32	33.69	54.00	-20.31	AVG	

ATTACHMENT E - BANDWIDTH

Test Mode : TX B Mode_CH01/06/11

Frequency (MHz)	6dB Bandwidth (MHz)	99% Occupied BW (MHz)	Min. Limit (kHz)	Test Result
2412	12.07	16.24	500	Complies
2437	12.10	16.20	500	Complies
2462	12.08	16.20	500	Complies

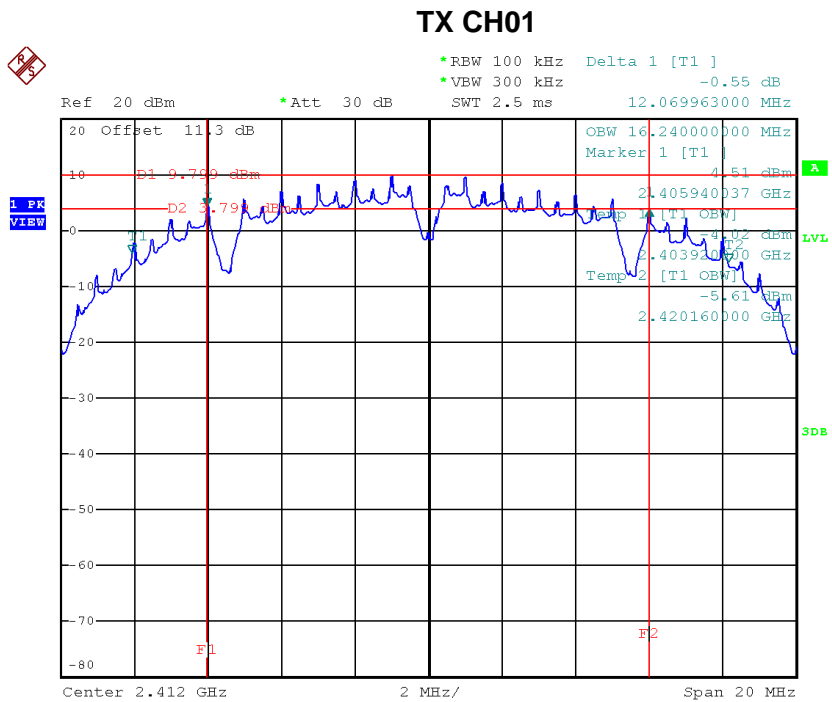

Date: 12.JAN.2017 12:34:04

TX CH06

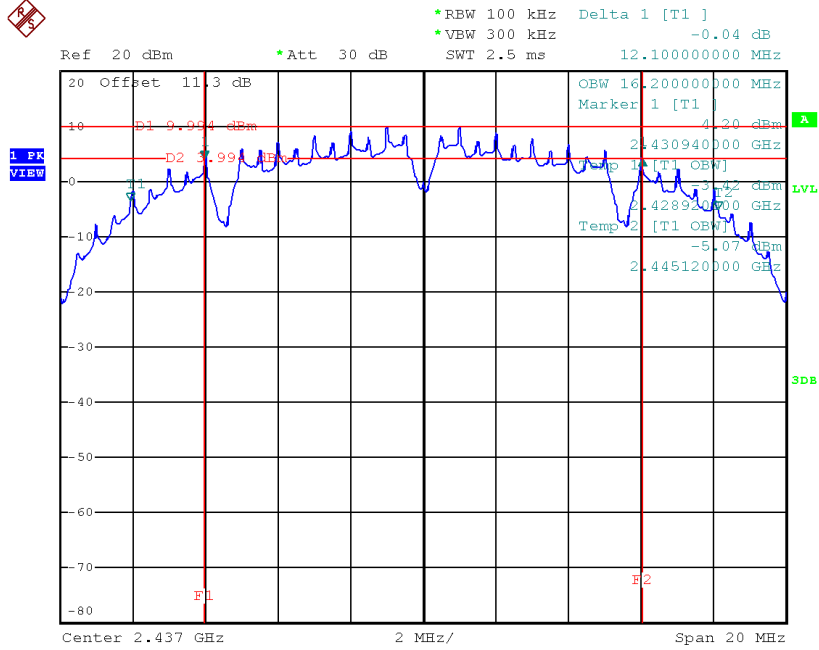

Date: 12.JAN.2017 14:16:20

TX CH11

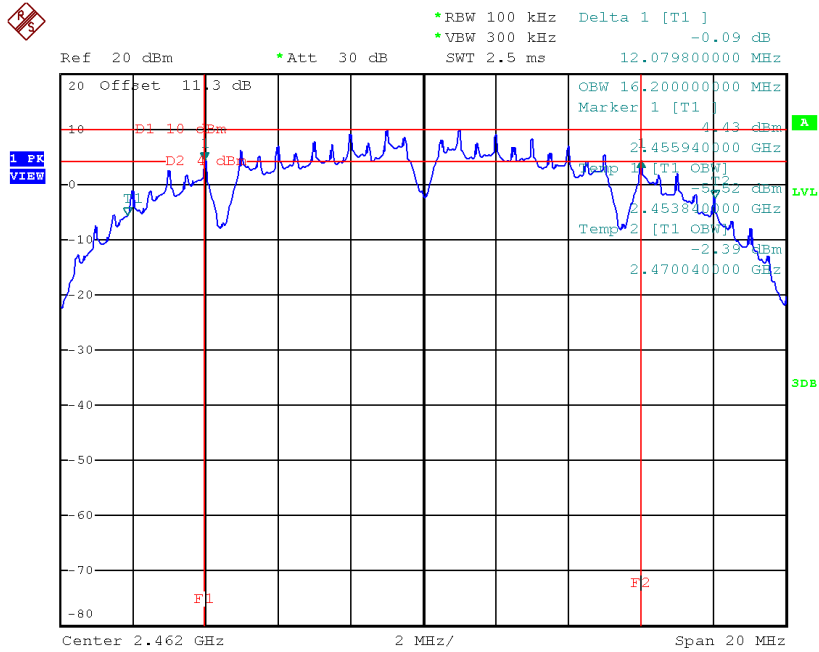

Date: 12.JAN.2017 14:19:44

Test Mode: TX G Mode_CH01/06/11

Frequency (MHz)	6dB Bandwidth (MHz)	99% Occupied BW (MHz)	Min. Limit (kHz)	Test Result
2412	15.40	16.36	500	Complies
2437	15.16	16.36	500	Complies
2462	15.52	16.36	500	Complies

TX CH01

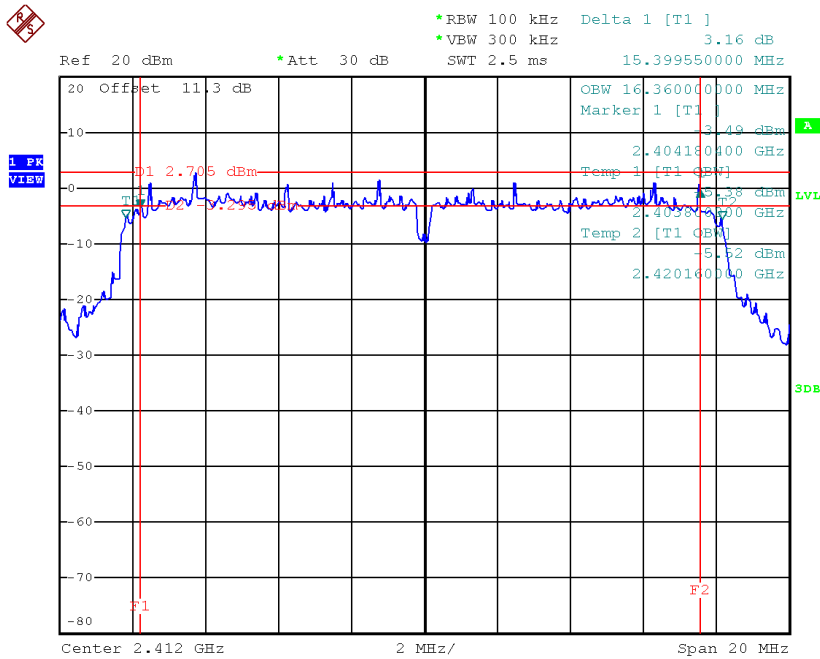

Date: 12.JAN.2017 14:24:22

TX CH06

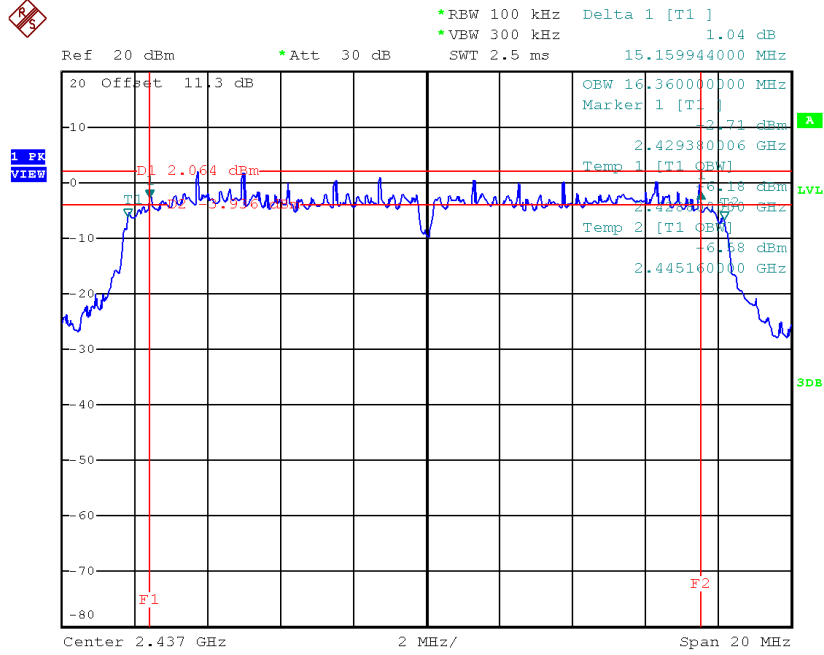

Date: 12.JAN.2017 14:28:44

TX CH11

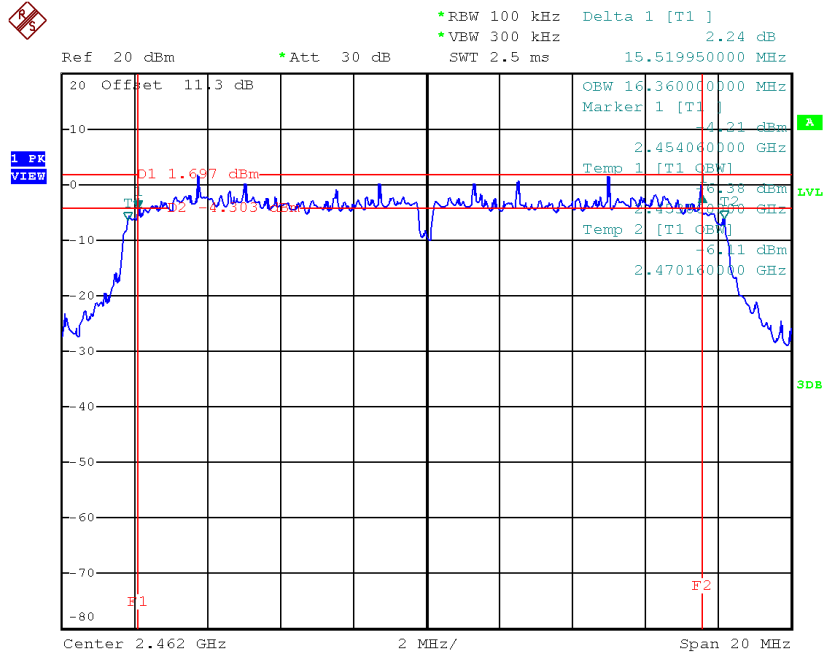

Date: 12.JAN.2017 14:35:37

Test Mode : TX N-20MHz Mode_CH01/06/11

Frequency (MHz)	6dB Bandwidth (MHz)	99% Occupied BW (MHz)	Min. Limit (kHz)	Test Result
2412	15.48	17.32	500	Complies
2437	15.80	17.32	500	Complies
2462	15.52	17.28	500	Complies

TX CH01

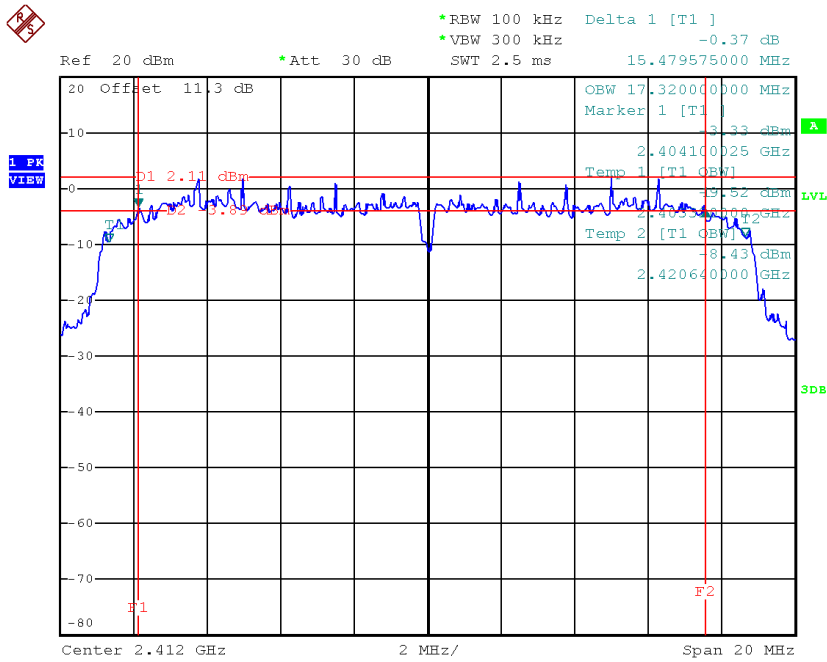

Date: 12.JAN.2017 18:37:20

TX CH06

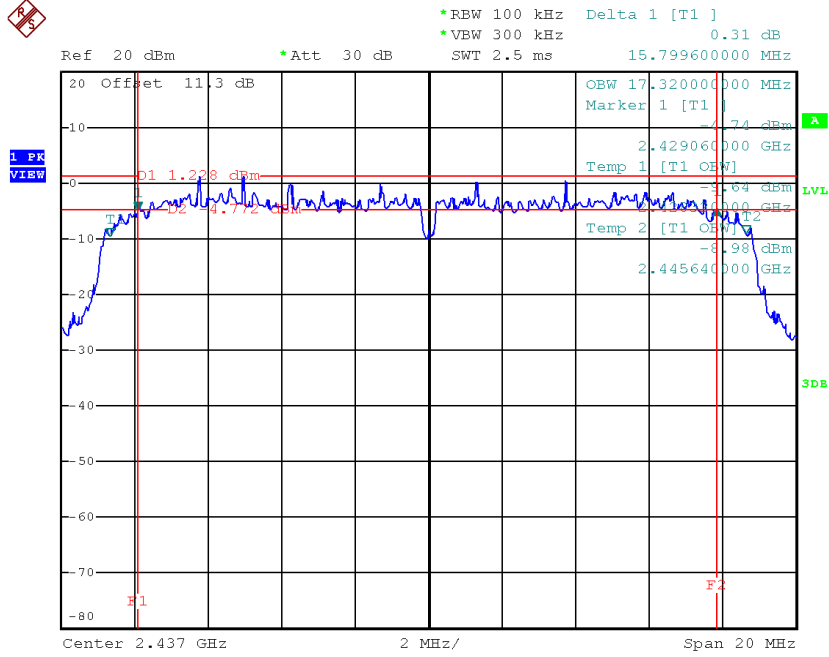

Date: 12.JAN.2017 18:35:07

TX CH11

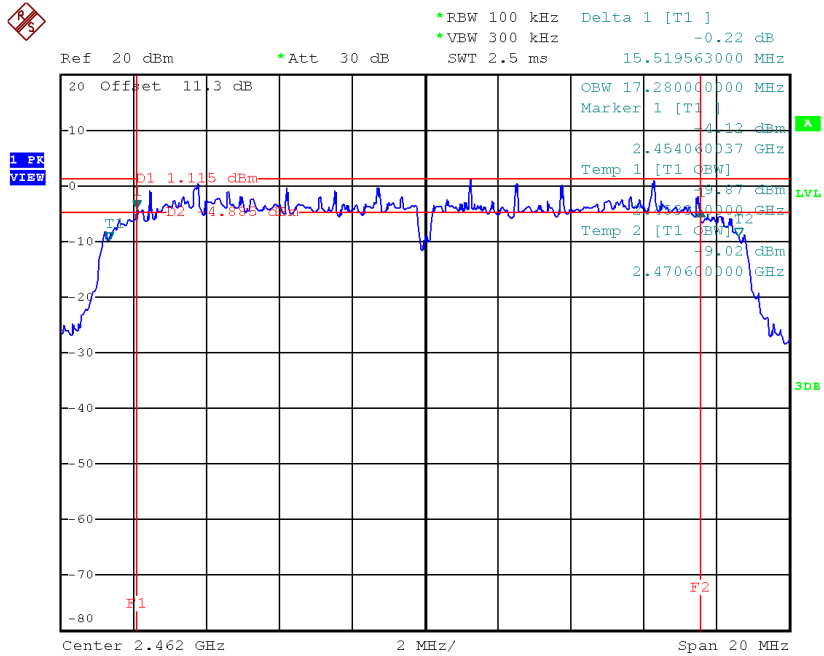

Date: 12.JAN.2017 18:31:45

**ATTACHMENT F – MAXIMUM PEAK CONDUCTED OUTPUT
POWER**

Test Mode :TX B Mode_CH01/06/11					
Frequency (MHz)	Conducted Power (dBm)	Conducted Power (W)	Max. Limit (dBm)	Max. Limit (W)	Result
2412	21.91	0.16	30.00	1.00	Complies
2437	21.88	0.15	30.00	1.00	Complies
2462	21.75	0.15	30.00	1.00	Complies

Test Mode :TX G Mode_CH01/06/11					
Frequency (MHz)	Conducted Power (dBm)	Conducted Power (W)	Max. Limit (dBm)	Max. Limit (W)	Result
2412	20.44	0.11	30.00	1.00	Complies
2437	20.59	0.11	30.00	1.00	Complies
2462	20.22	0.11	30.00	1.00	Complies

Test Mode :TX N20 Mode_CH01/06/11					
Frequency (MHz)	Conducted Power (dBm)	Conducted Power (W)	Max. Limit (dBm)	Max. Limit (W)	Result
2412	19.72	0.09	30.00	1.00	Complies
2437	20.49	0.11	30.00	1.00	Complies
2462	19.97	0.10	30.00	1.00	Complies

**ATTACHMENT G - ANTENNA CONDUCTED SPURIOUS
EMISSION**

Test Mode : TX B Mode

TX B mode CH01

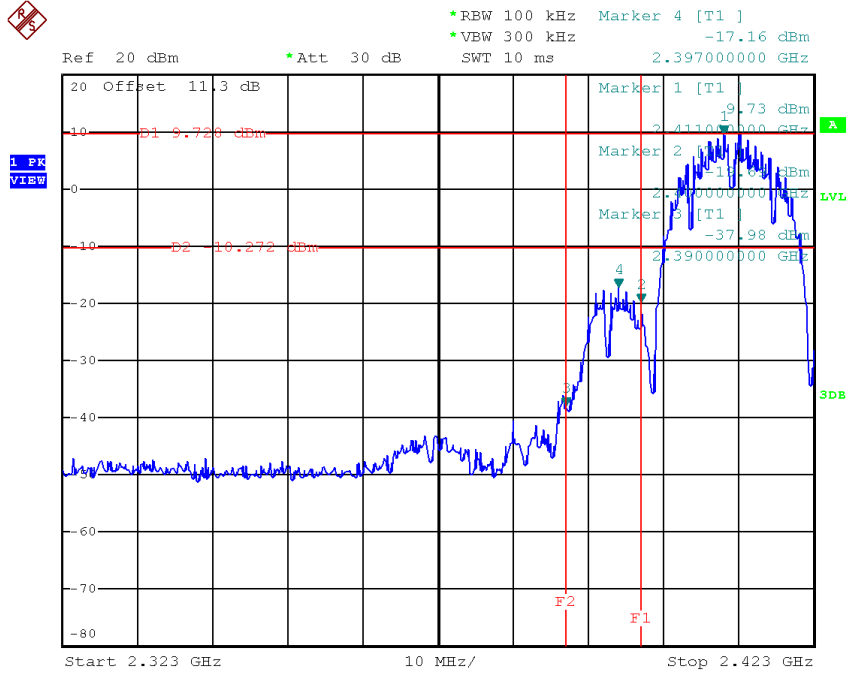

Date: 12.JAN.2017 12:34:38

TX B mode CH11

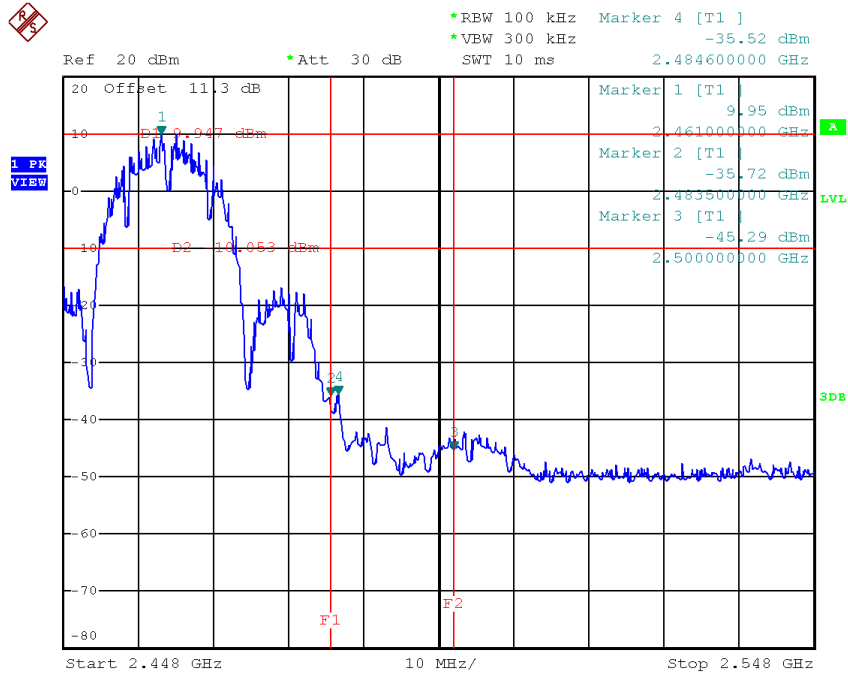

Date: 12.JAN.2017 14:20:34

TX B mode CH01 (10 Harmonic of the frequency)

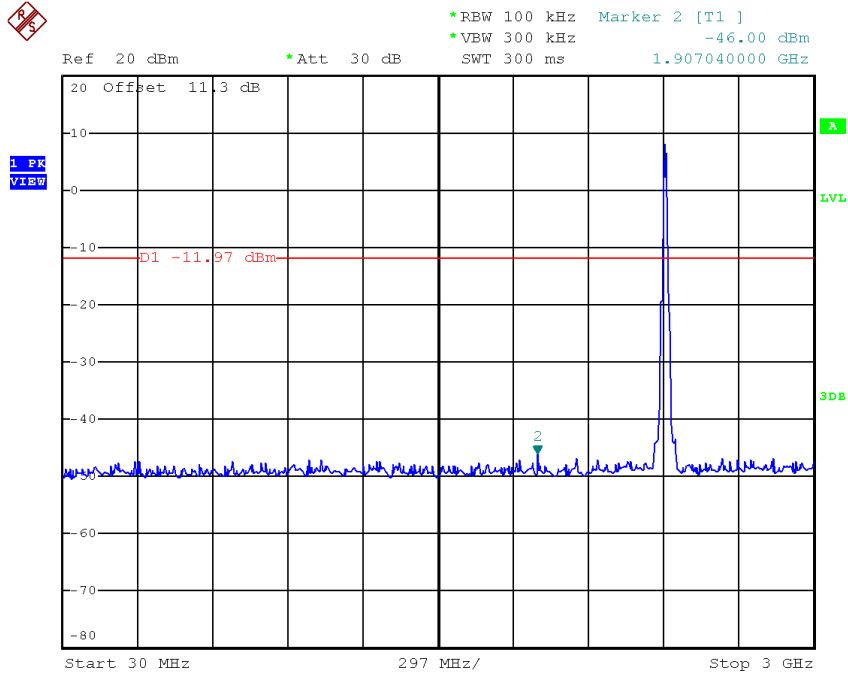

Date: 12.JAN.2017 12:34:18

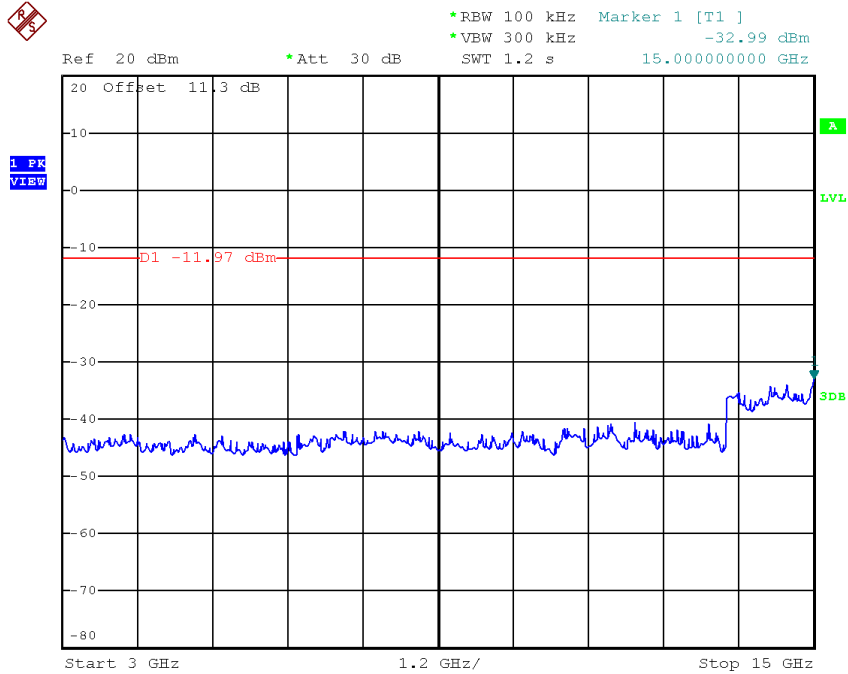

Date: 12.JAN.2017 12:34:24

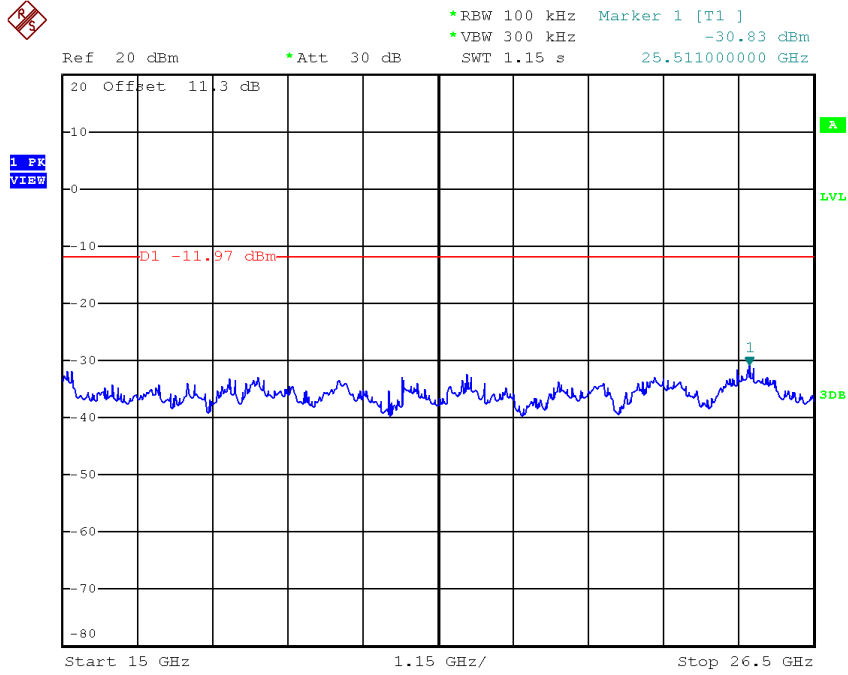

Date: 12.JAN.2017 12:34:31

TX B mode CH06 (10 Harmonic of the frequency)

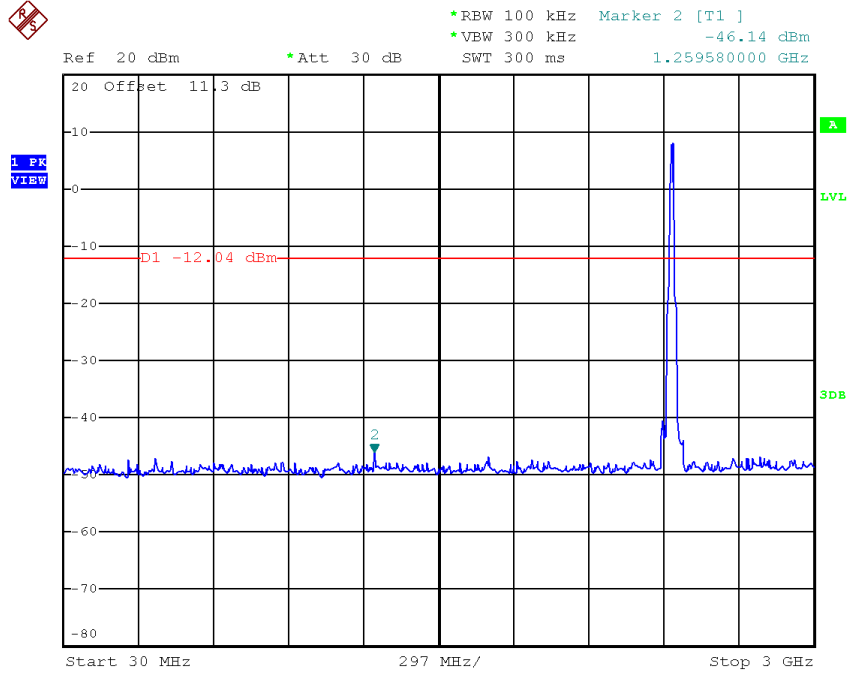

Date: 12.JAN.2017 14:16:35

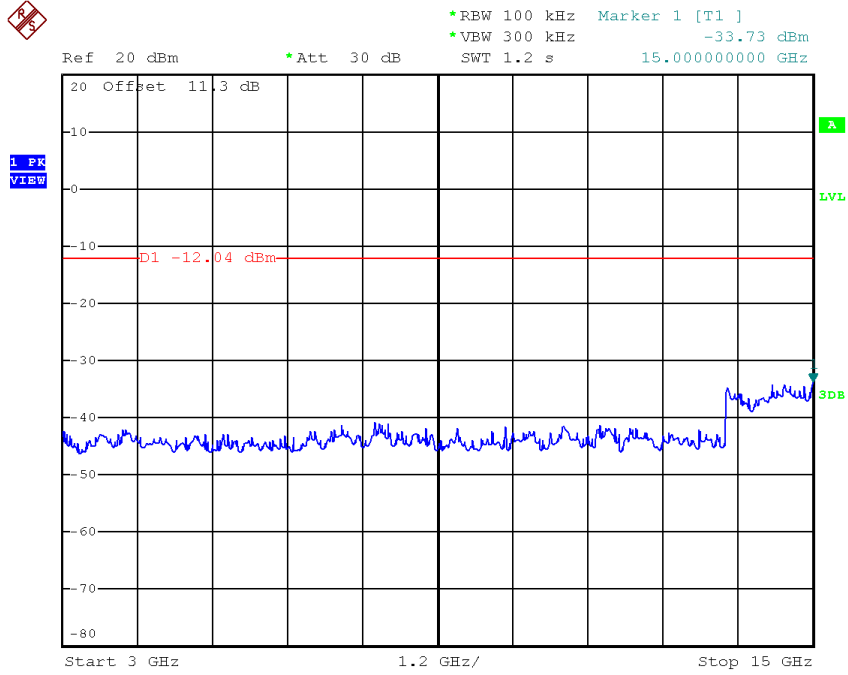

Date: 12.JAN.2017 14:16:42

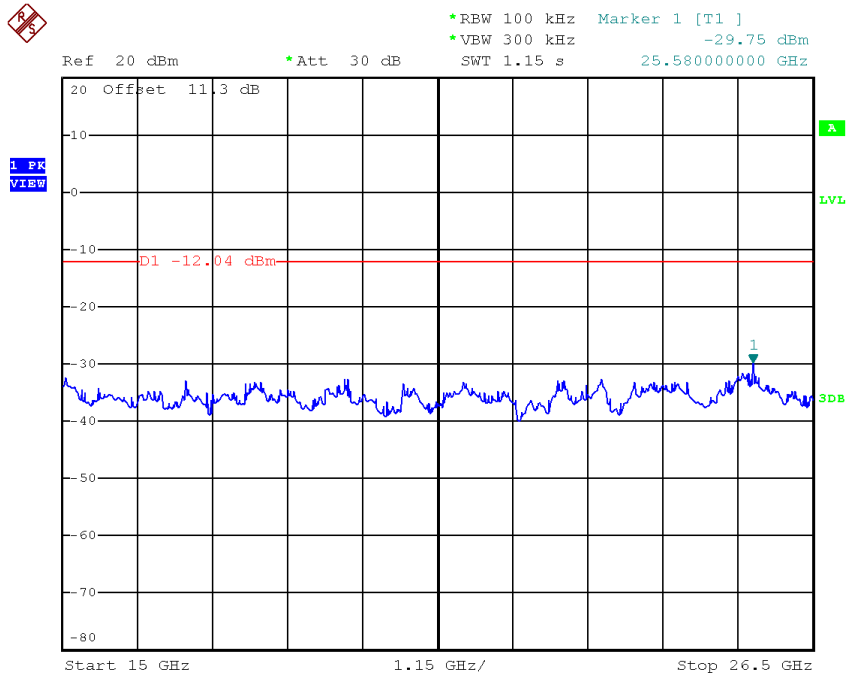

Date: 12.JAN.2017 14:16:49

TX B mode CH11 (10 Harmonic of the frequency)

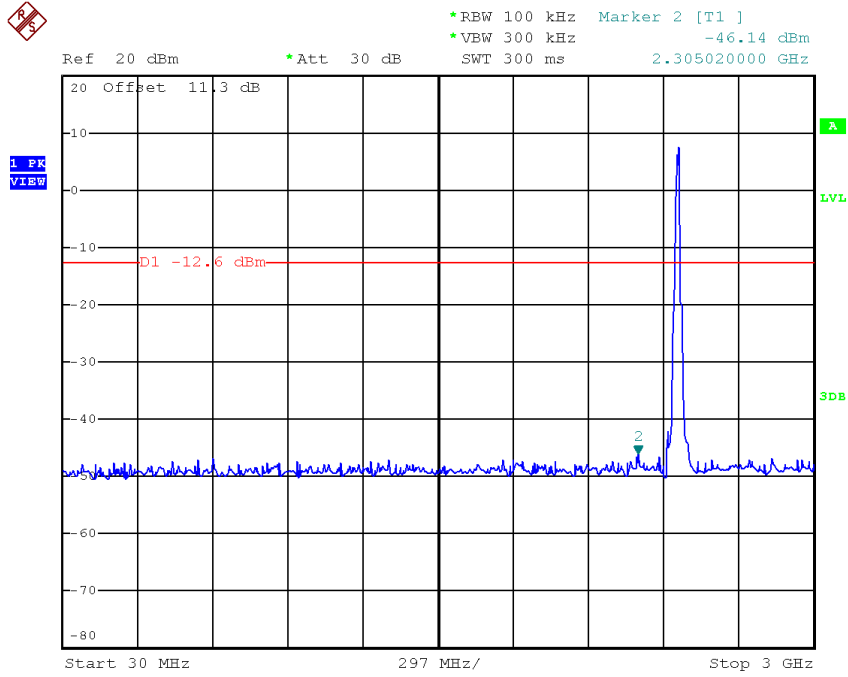

Date: 12.JAN.2017 14:19:57

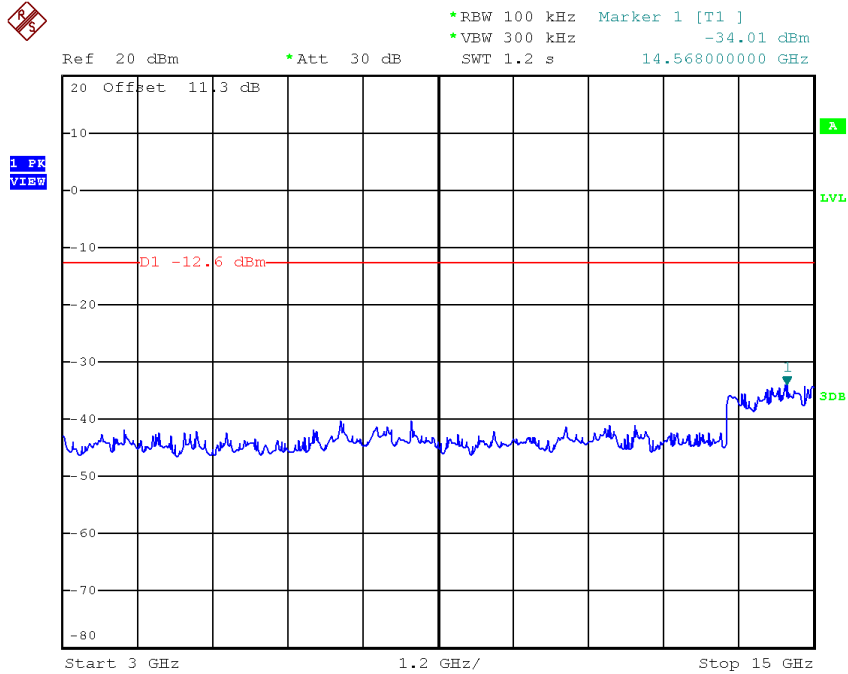

Date: 12.JAN.2017 14:20:04



Ref 20 dBm *Att 30 dB *RBW 100 kHz Marker 1 [T1] -29.31 dBm
*VBW 300 kHz SWT 1.15 s 25.580000000 GHz

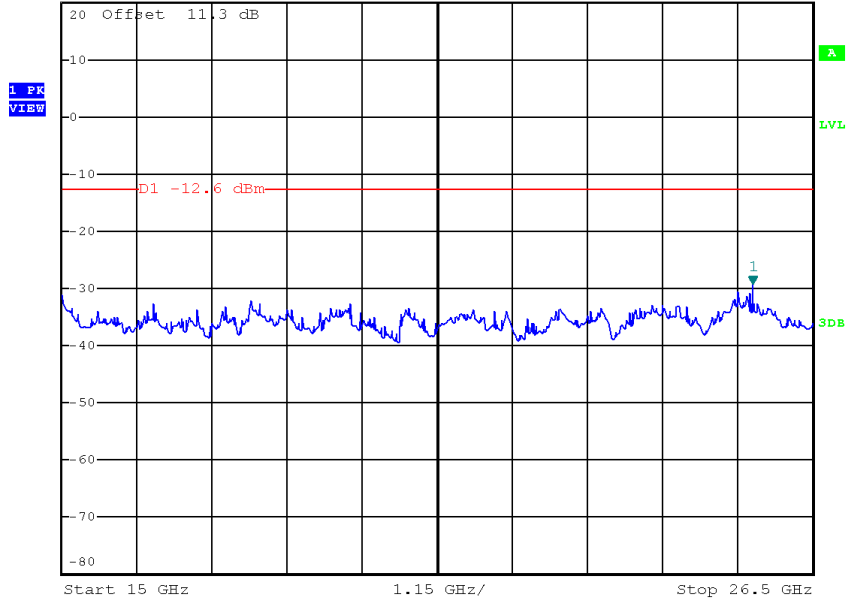

Date: 12.JAN.2017 14:20:11

Test Mode : TX G Mode

TX G mode CH01

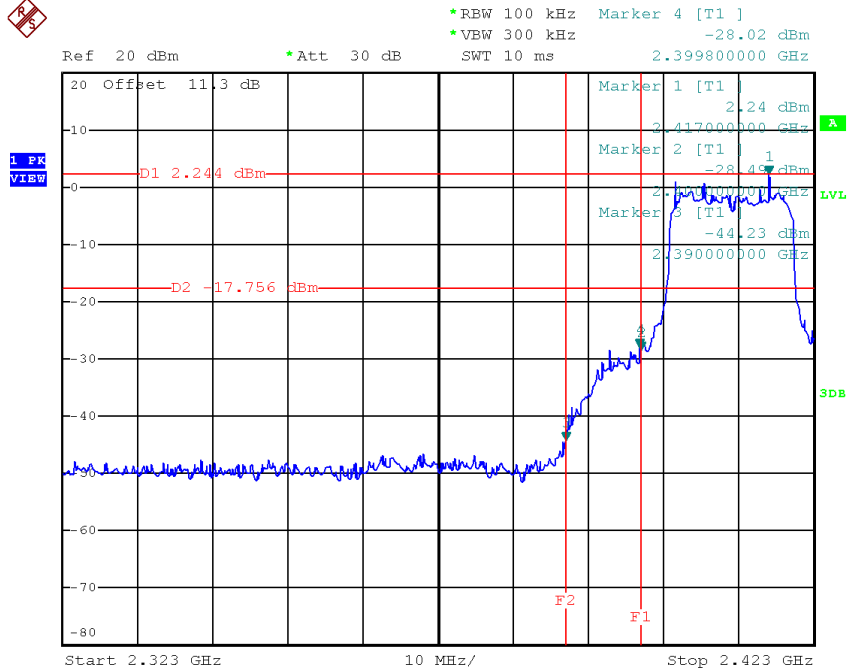

Date: 12.JAN.2017 14:24:56

TX G mode CH11

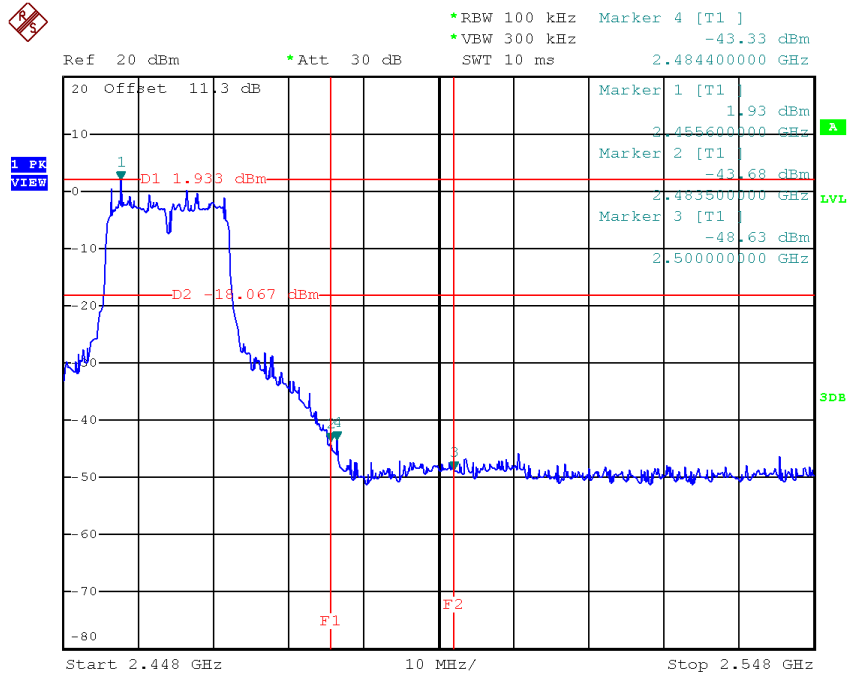

Date: 12.JAN.2017 14:36:12

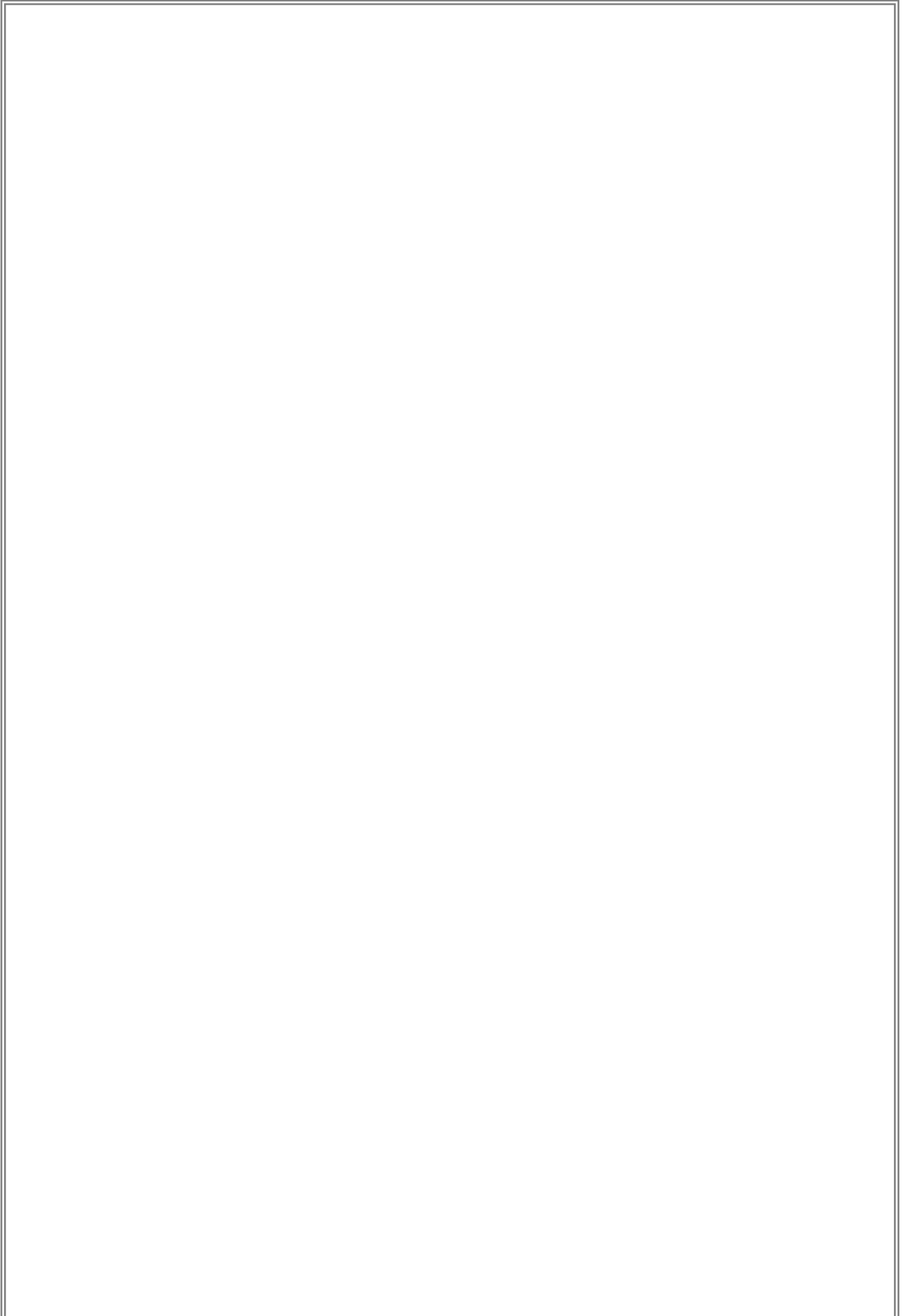

TX G mode CH01 (10 Harmonic of the frequency)

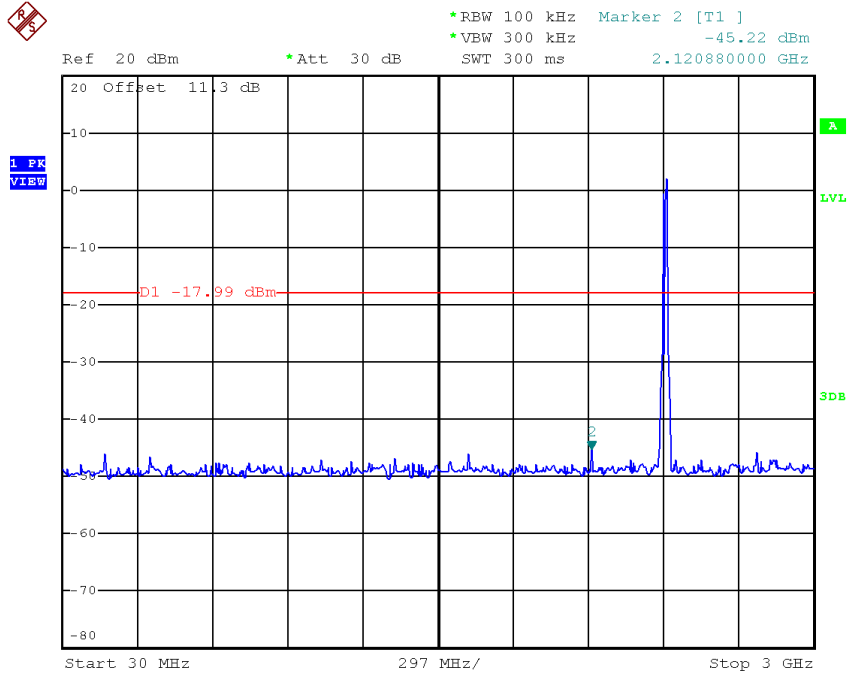

Date: 12.JAN.2017 14:24:35

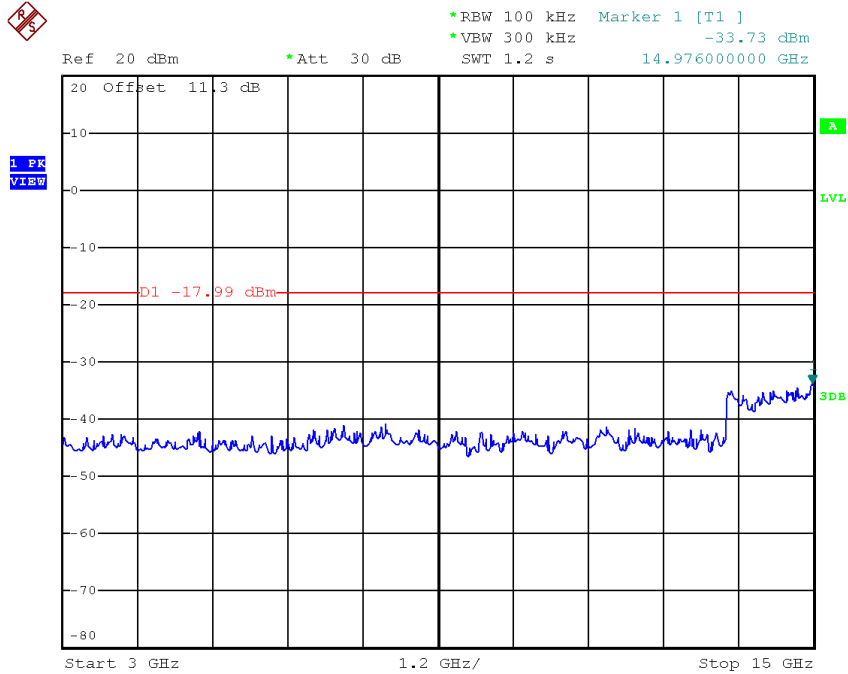

Date: 12.JAN.2017 14:24:42

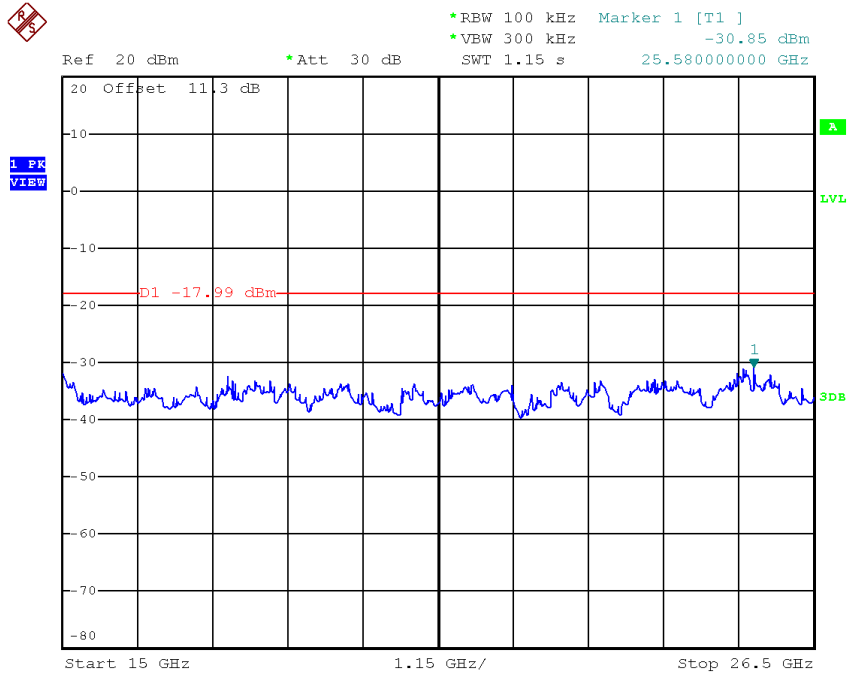

Date: 12.JAN.2017 14:24:49

TX G mode CH06 (10 Harmonic of the frequency)

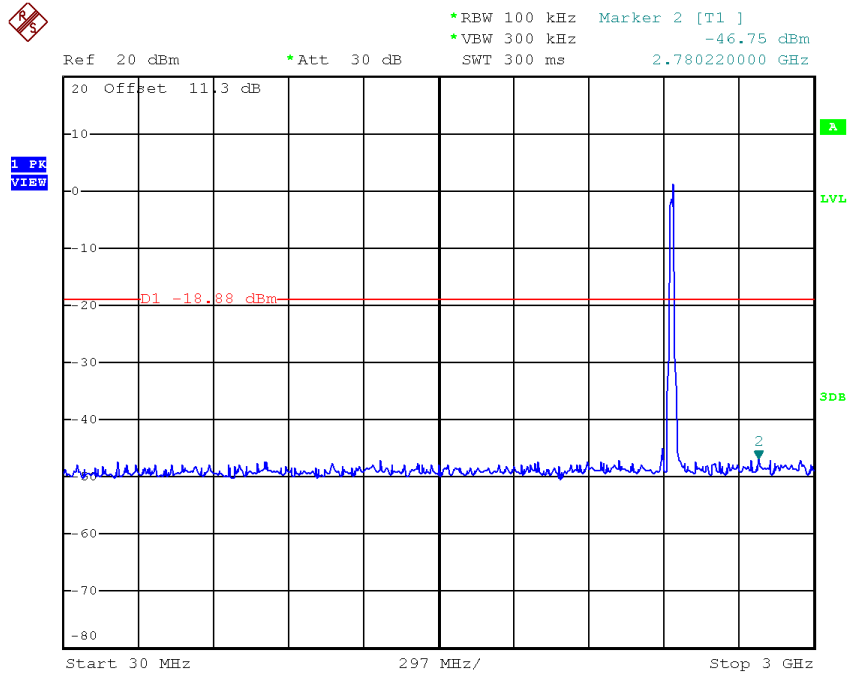

Date: 12.JAN.2017 14:28:57

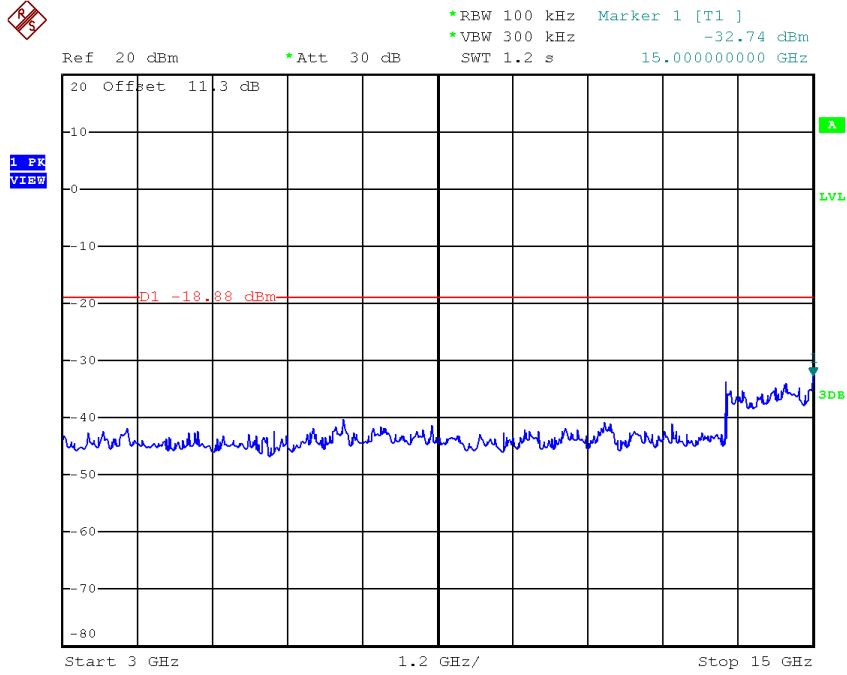

Date: 12.JAN.2017 14:29:04

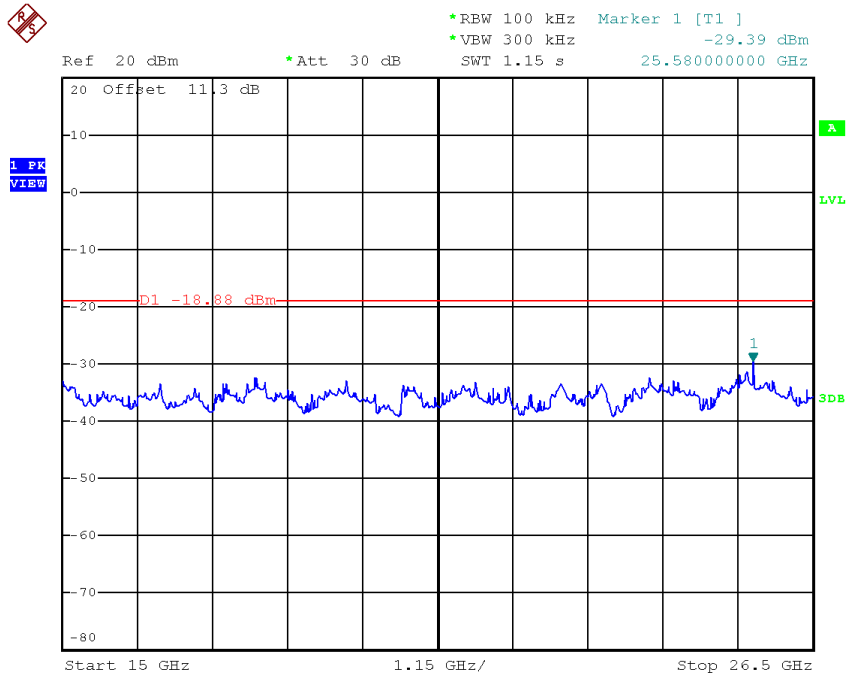

Date: 12.JAN.2017 14:29:11

TX G mode CH11 (10 Harmonic of the frequency)

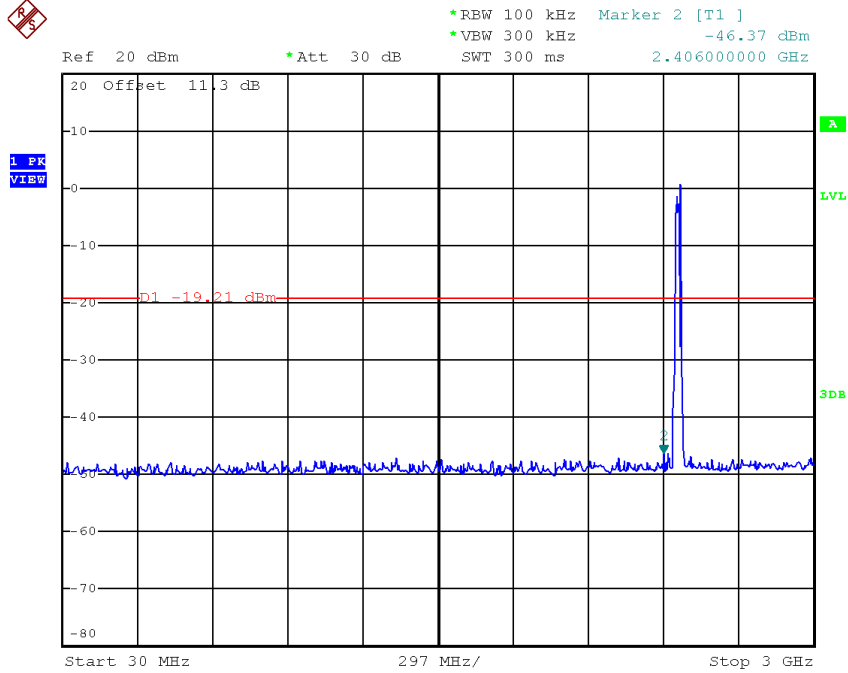

Date: 12.JAN.2017 14:35:51

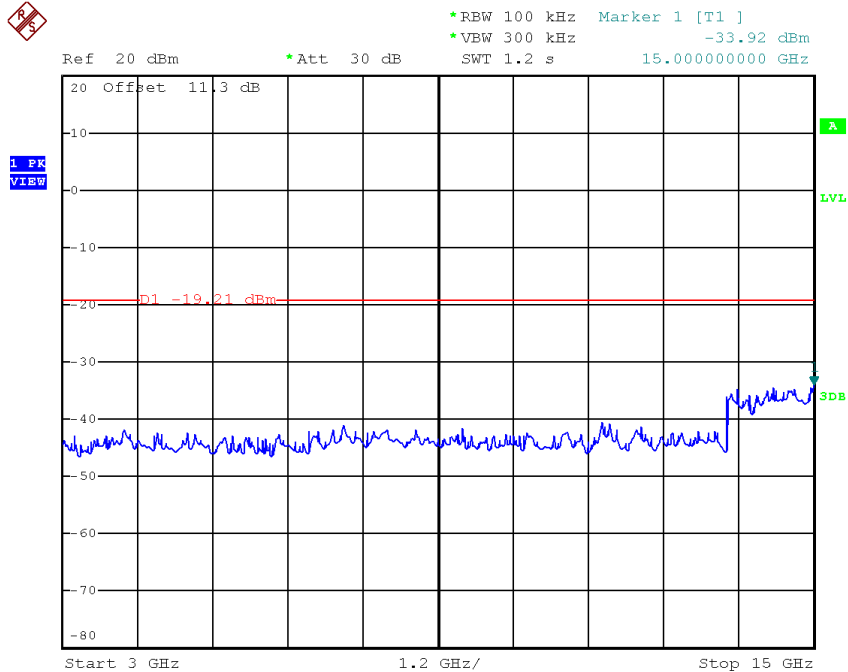

Date: 12.JAN.2017 14:35:58



Ref 20 dBm *Att 30 dB *RBW 100 kHz Marker 1 [T1] -28.90 dBm
 *VBW 300 kHz SWT 1.15 s 25.580000000 GHz

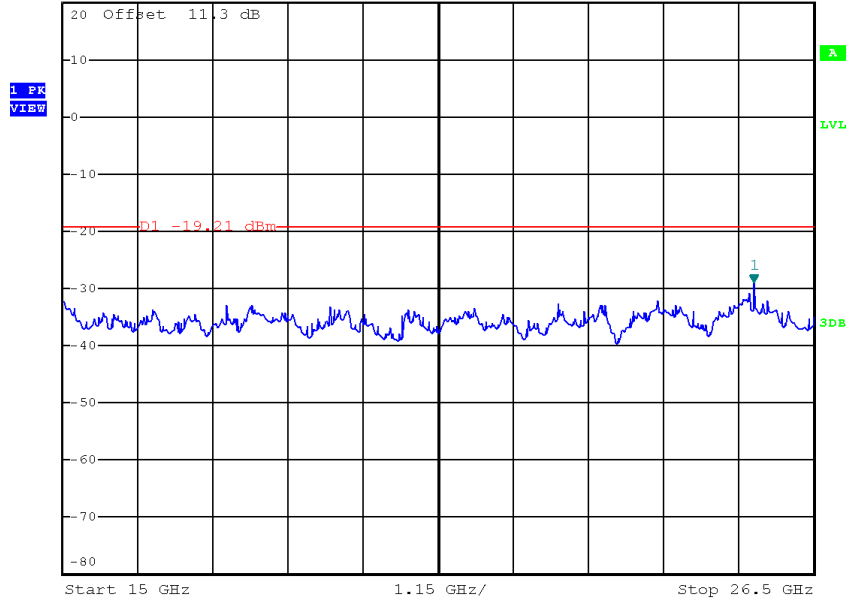

Date: 12.JAN.2017 14:36:05

Test Mode : TX N-20M Mode

TX HT20 mode CH01

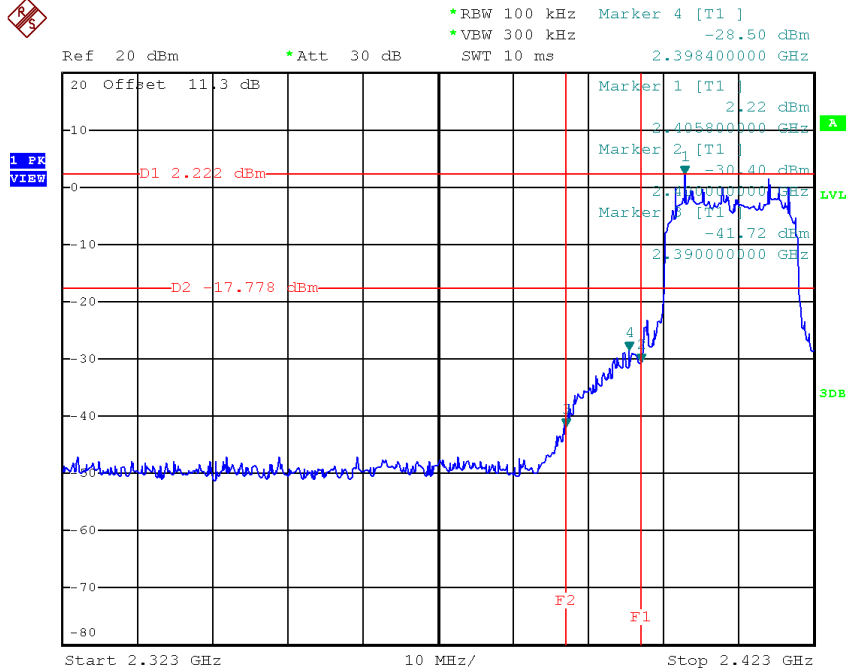

Date: 12.JAN.2017 18:37:54

TX HT20 mode CH11

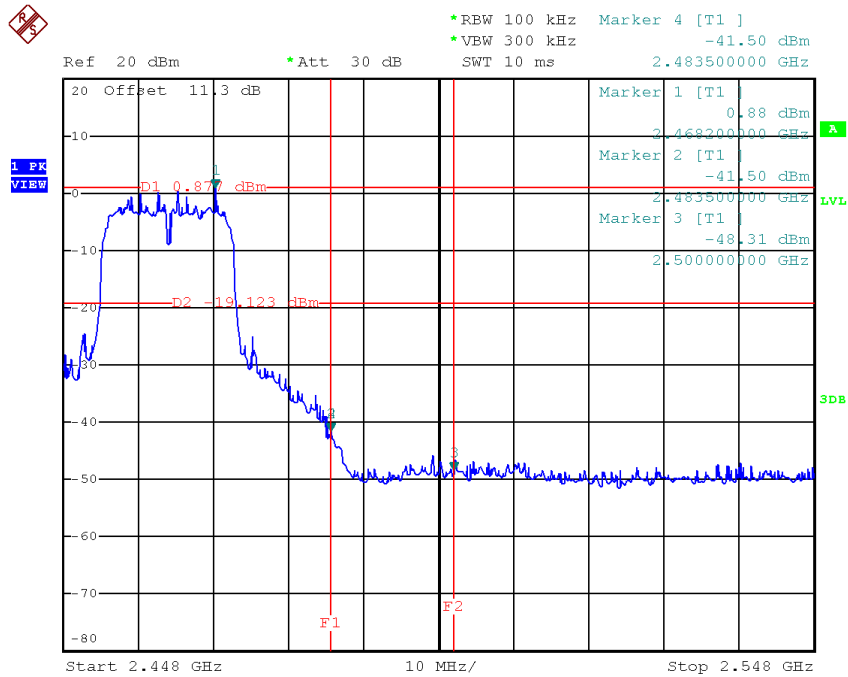

Date: 12.JAN.2017 18:32:36

TX HT20 mode CH01 (10 Harmonic of the frequency)

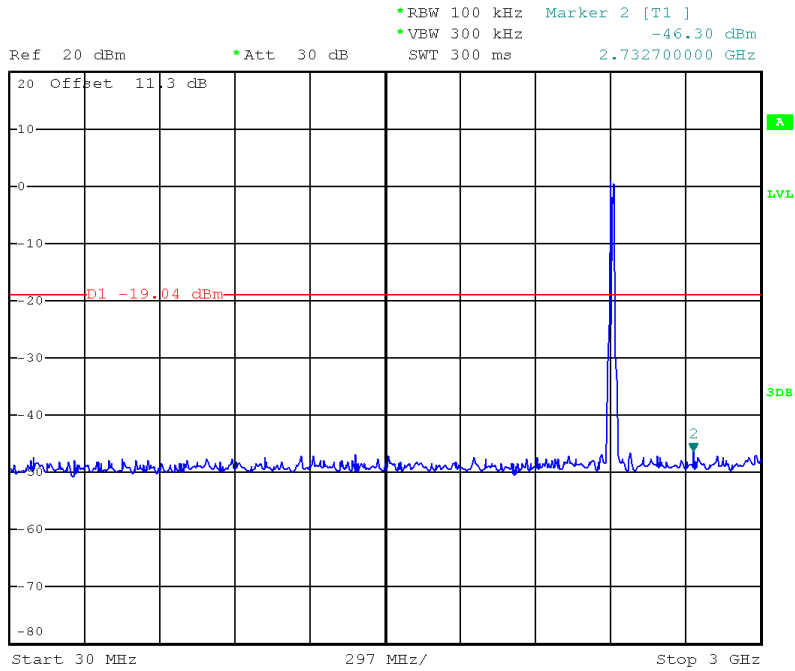

Date: 12.JAN.2017 18:37:33

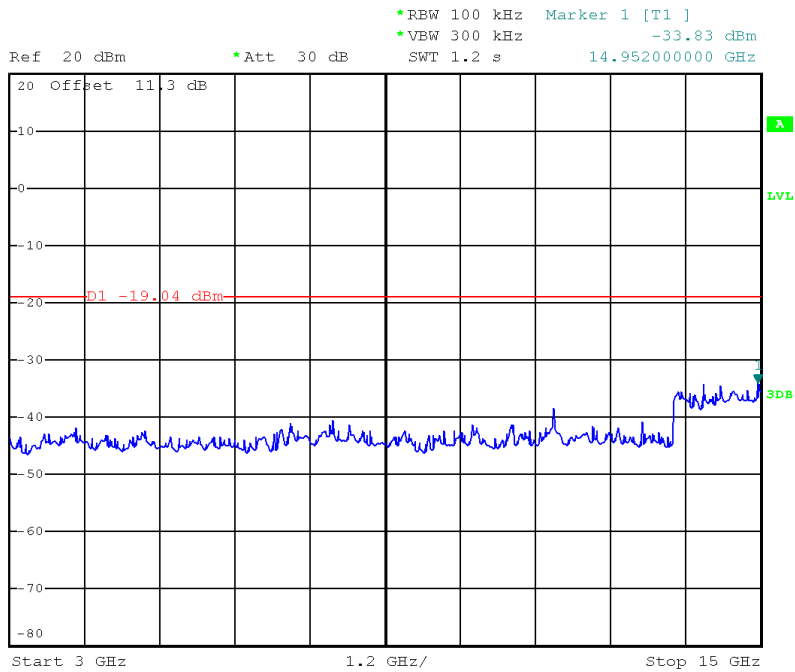

Date: 12.JAN.2017 18:37:40

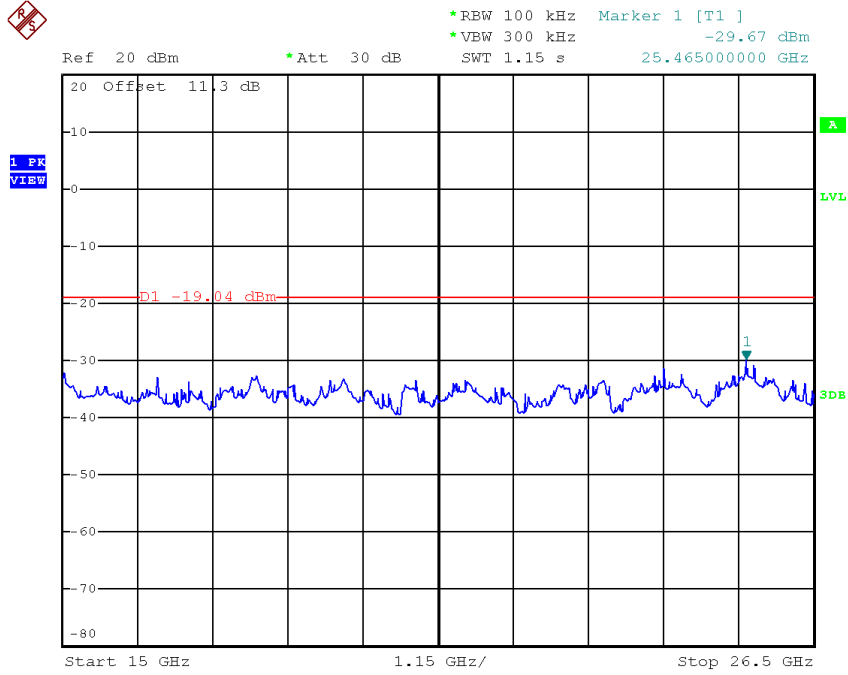

Date: 12.JAN.2017 18:37:47

TX HT20 mode CH06 (10 Harmonic of the frequency)

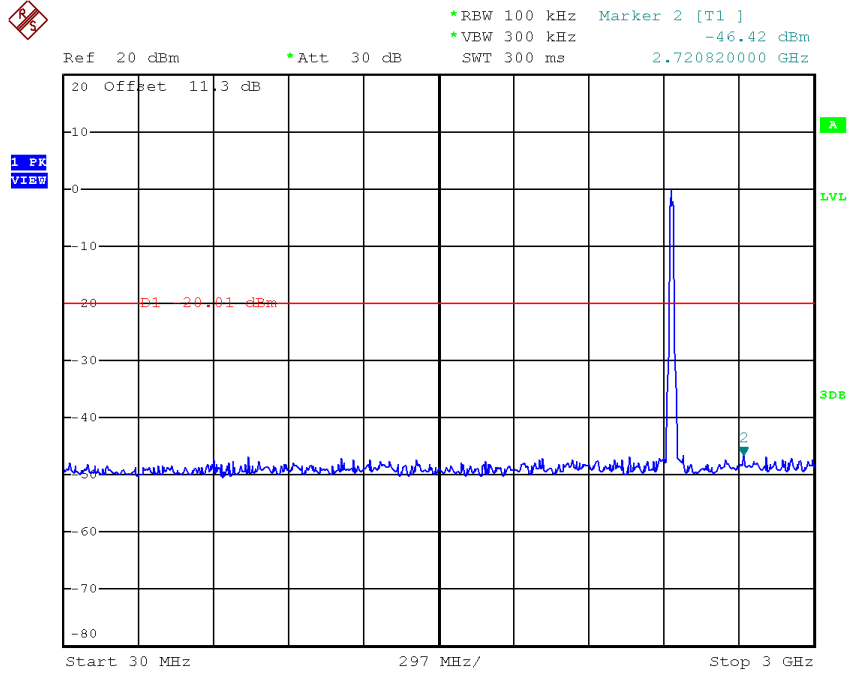

Date: 12.JAN.2017 18:35:21



Ref 20 dBm *Att 30 dB *RBW 100 kHz Marker 1 [T1]
 *VBW 300 kHz -33.96 dBm
 SWT 1.2 s 14.280000000 GHz

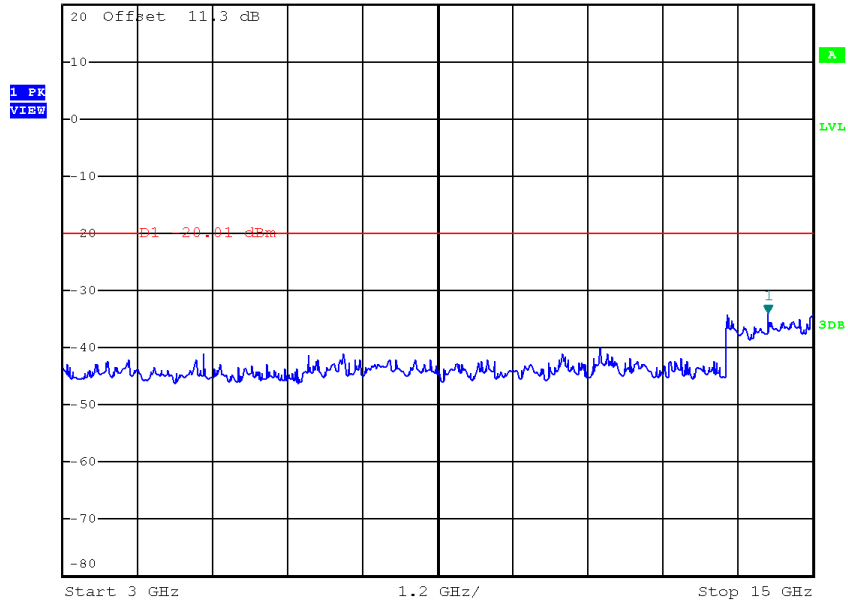

Date: 12.JAN.2017 18:35:28



Ref 20 dBm *Att 30 dB *RBW 100 kHz Marker 1 [T1]
 *VBW 300 kHz -30.93 dBm
 SWT 1.15 s 25.580000000 GHz

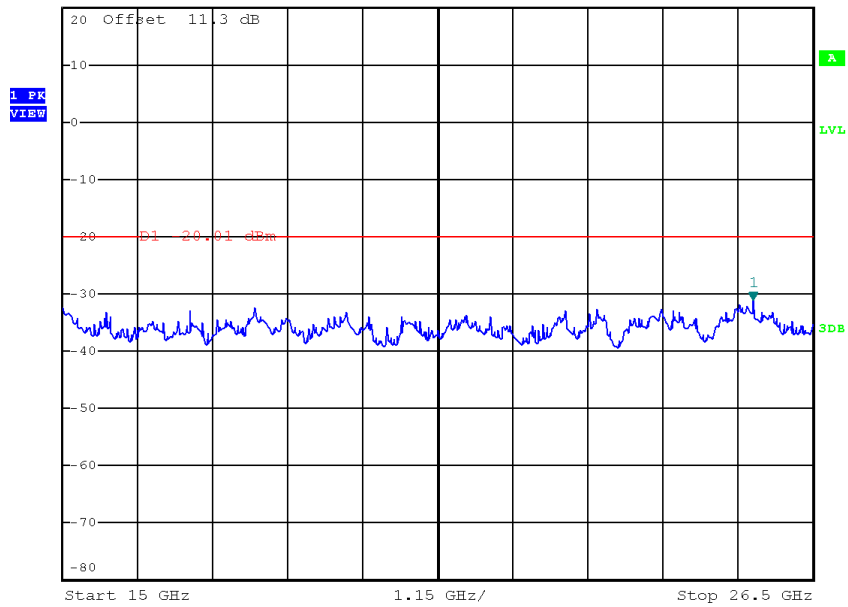

Date: 12.JAN.2017 18:35:34

TX HT20 mode CH11 (10 Harmonic of the frequency)

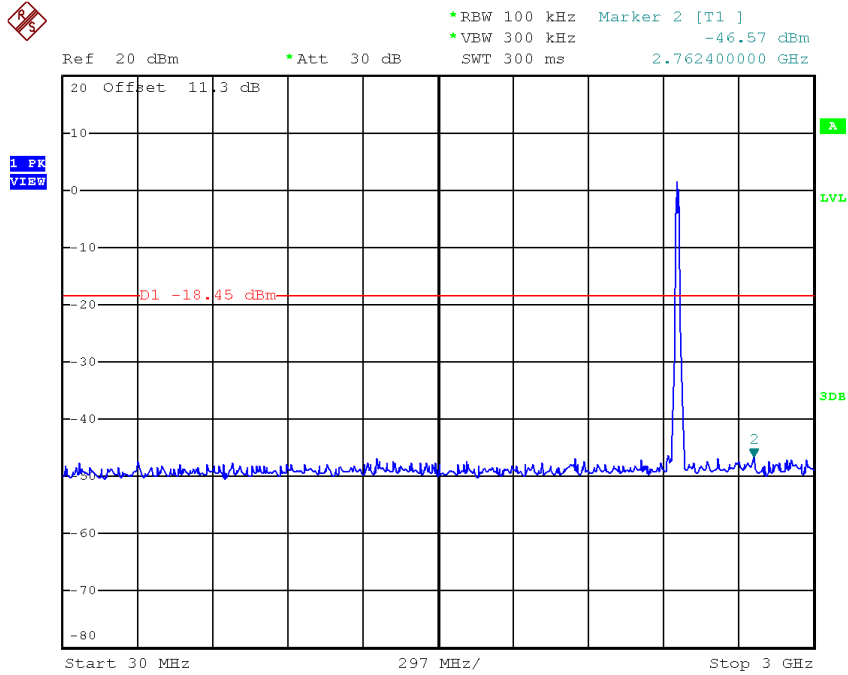

Date: 12.JAN.2017 18:31:58

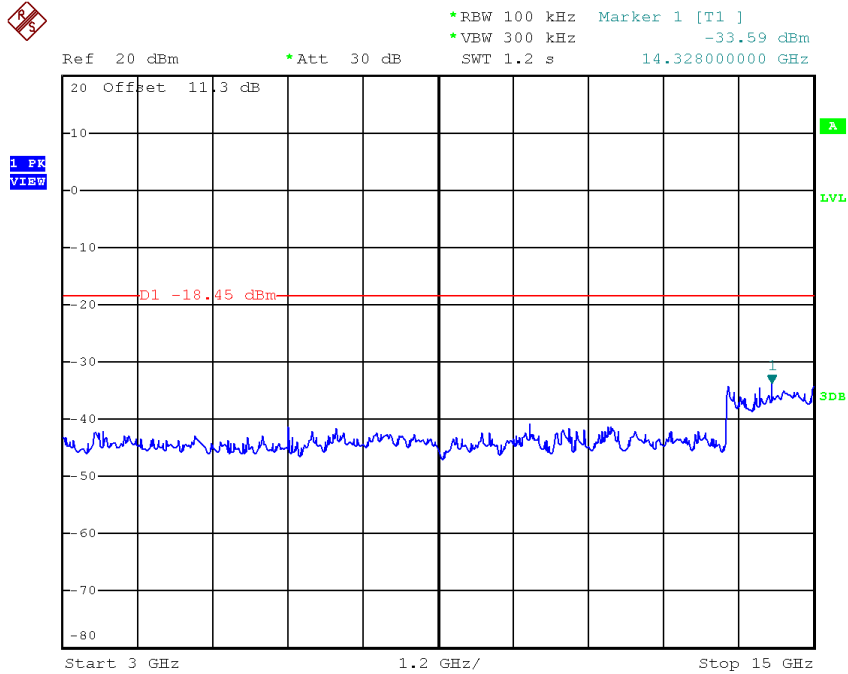

Date: 12.JAN.2017 18:32:05



Ref 20 dBm *Att 30 dB *RBW 100 kHz Marker 1 [T1] -28.37 dBm
*VBW 300 kHz SWT 1.15 s 25.580000000 GHz

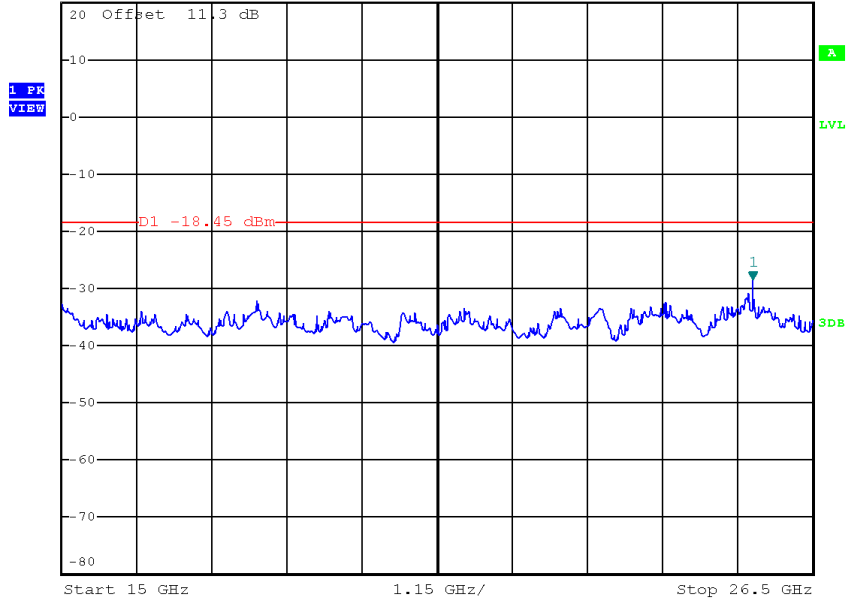

Date: 12.JAN.2017 18:32:12

ATTACHMENT H - POWER SPECTRAL DENSITY

For 1T1R

Test Mode :TX B Mode_CH01/06/11

Frequency (MHz)	Power Density (dBm/3kHz)	Power Density (mW/3kHz)	Max. Limit (dBm/3kHz)	Result
2412	-10.06	0.0986	8.00	Complies
2437	-7.14	0.1932	8.00	Complies
2462	-7.51	0.1774	8.00	Complies

TX CH01

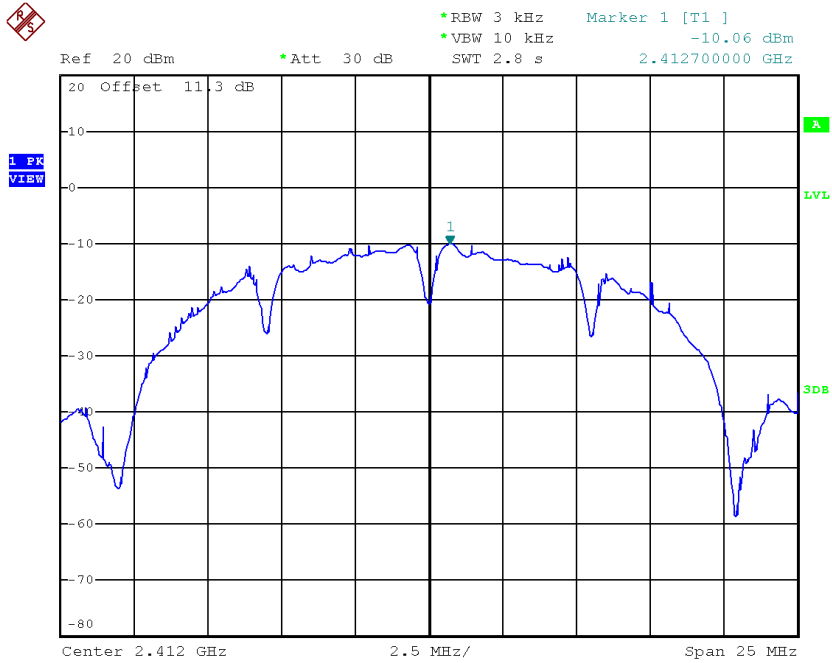

Date: 12.JAN.2017 12:36:07

TX CH06

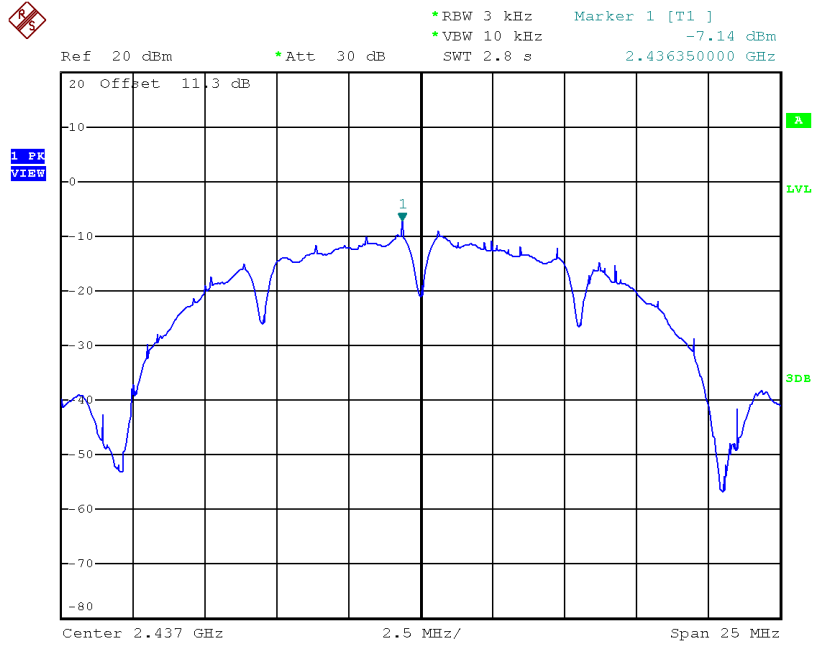

Date: 12.JAN.2017 14:17:28

TX CH11

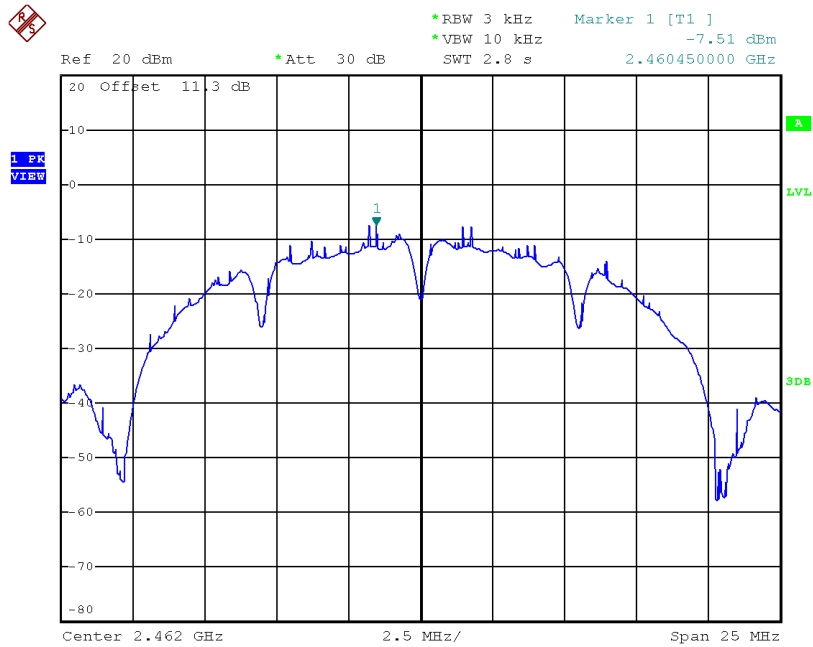

Date: 12.JAN.2017 14:22:43

Test Mode :TX G Mode_CH01/06/11

Frequency (MHz)	Power Density (dBm/3kHz)	Power Density (mW/3kHz)	Max. Limit (dBm/3kHz)	Result
2412	-14.62	0.0345	8.00	Complies
2437	-15.55	0.0279	8.00	Complies
2462	-15.57	0.0277	8.00	Complies

TX CH01

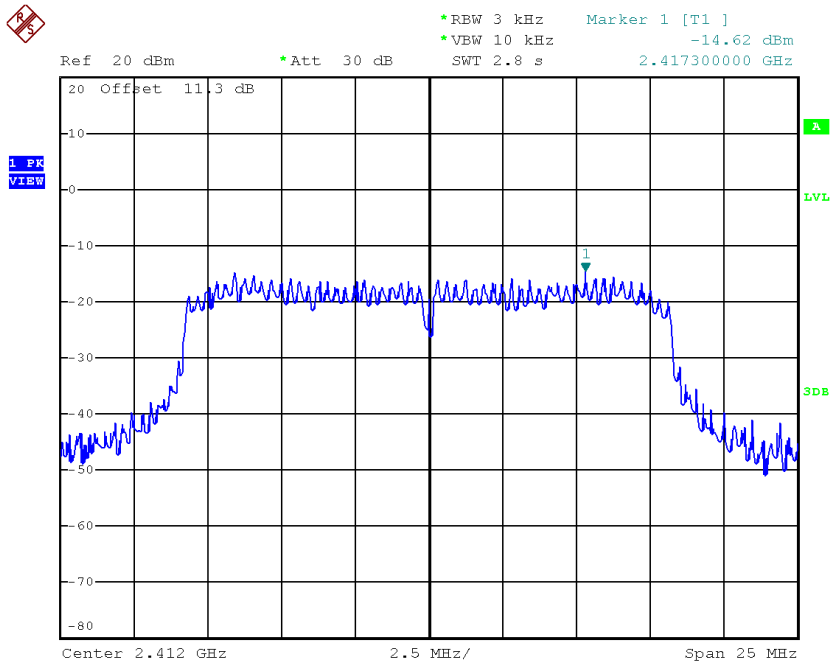

Date: 12.JAN.2017 14:26:08

TX CH06

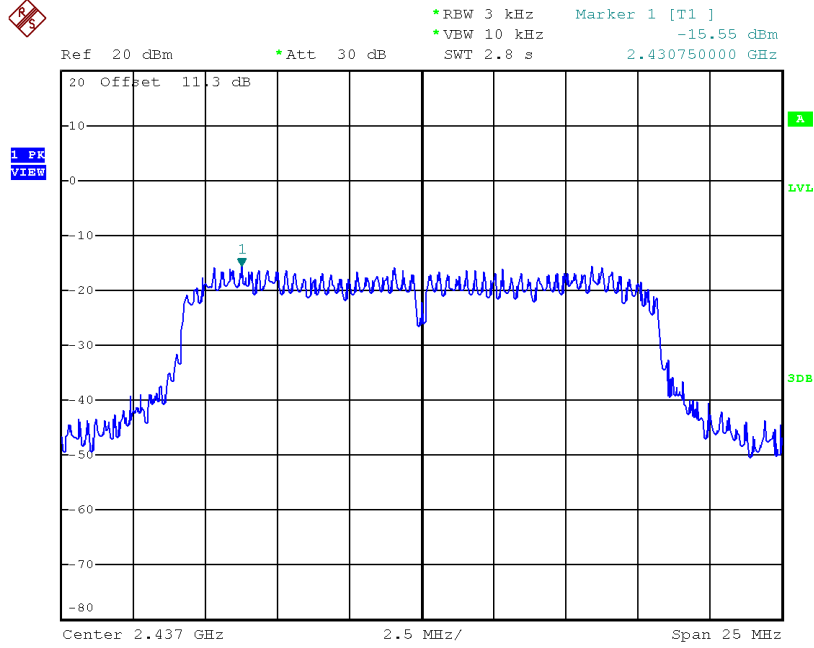

Date: 12.JAN.2017 14:29:20

TX CH11

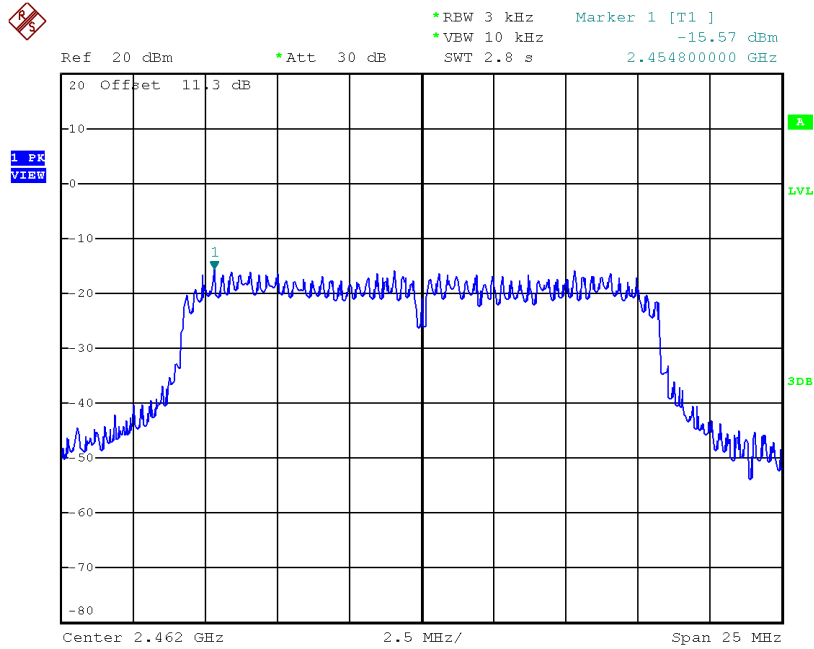

Date: 12.JAN.2017 14:36:20

Test Mode : TX N-20M Mode_CH01/06/11

Frequency (MHz)	Power Density (dBm/3kHz)	Power Density (mW/3kHz)	Max. Limit (dBm/3kHz)	Result
2412	-15.16	0.0305	8.00	Complies
2437	-14.60	0.0347	8.00	Complies
2462	-15.76	0.0265	8.00	Complies

TX CH01

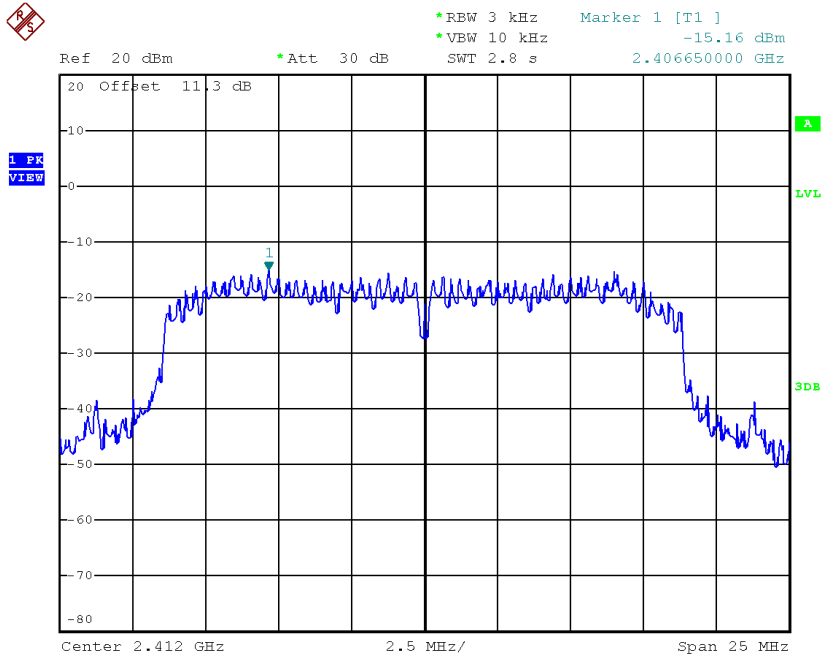

Date: 12.JAN.2017 18:38:02

TX CH06

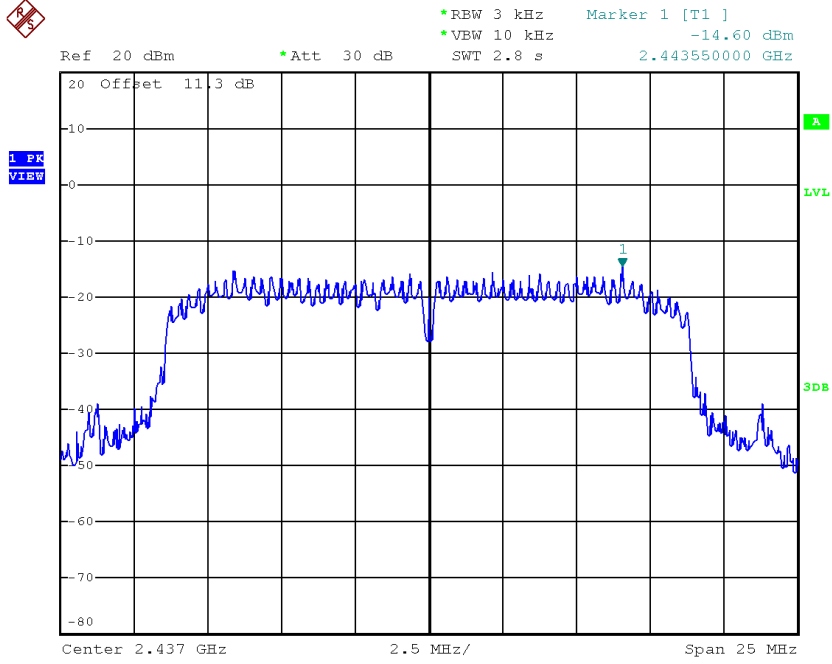

Date: 12.JAN.2017 18:35:43

TX CH11

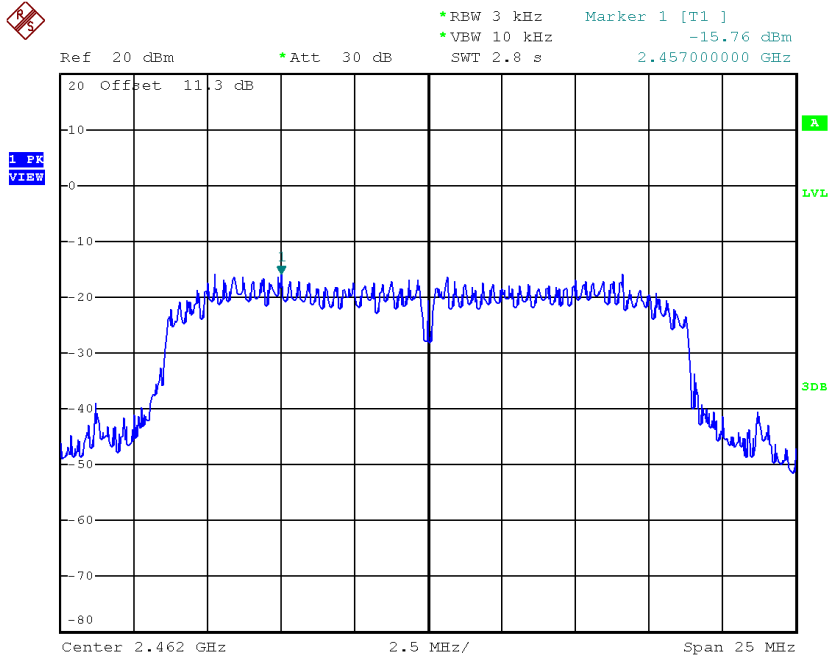

Date: 12.JAN.2017 18:33:12