



**FCC 47 CFR PART 15 SUBPART C  
CERTIFICATION TEST REPORT  
FOR**

**Tablet with Bluetooth, DTS/UNII a/b/g/n/ac, ANT+ and NFC**

**FCC ID: PY7TS-0040**

**REPORT NUMBER: 14U17934-E2 REVISION B**

**ISSUE DATE: SEPTEMBER 18, 2014**

*Prepared for*  
**SONY MOBILE COMMUNICATIONS, INC.  
NYA VATTENTORNET MOBILVAGEN 10  
LUND 22188  
SWEDEN**

*Prepared by*  
**UL VERIFICATION SERVICES INC.  
47173 BENICIA STREET  
FREMONT, CA 94538, U.S.A.  
TEL: (510) 771-1000  
FAX: (510) 661-0888**



**NVLAP LAB CODE 200065-0**

Revision History

Rev.	Date	Revisions	Revised By
--	09/05/14	Initial issue	D. Corona
A	09/17/14	EUT description updated	D. Corona
B	09/18/14	EUT description updated; cover page, 5, 8 & 12	D. Corona

## TABLE OF CONTENTS

<b>1. ATTESTATION OF TEST RESULTS .....</b>	<b>5</b>
<b>2. TEST METHODOLOGY .....</b>	<b>6</b>
<b>3. FACILITIES AND ACCREDITATION .....</b>	<b>6</b>
<b>4. CALIBRATION AND UNCERTAINTY .....</b>	<b>6</b>
4.1. <i>MEASURING INSTRUMENT CALIBRATION .....</i>	<i>6</i>
4.2. <i>SAMPLE CALCULATION .....</i>	<i>6</i>
4.3. <i>MEASUREMENT UNCERTAINTY.....</i>	<i>7</i>
<b>5. EQUIPMENT UNDER TEST.....</b>	<b>8</b>
5.1. <i>DESCRIPTION OF EUT .....</i>	<i>8</i>
5.2. <i>MAXIMUM OUTPUT POWER.....</i>	<i>8</i>
5.3. <i>DESCRIPTION OF AVAILABLE ANTENNAS .....</i>	<i>8</i>
5.4. <i>WORST-CASE CONFIGURATION AND MODE.....</i>	<i>8</i>
5.5. <i>DESCRIPTION OF TEST SETUP.....</i>	<i>9</i>
<b>6. TEST AND MEASUREMENT EQUIPMENT .....</b>	<b>11</b>
<b>7. SUMMARY TABLE .....</b>	<b>12</b>
<b>ANTENNA PORT TEST RESULTS.....</b>	<b>12</b>
7.1. <i>6 dB BANDWIDTH.....</i>	<i>13</i>
7.2. <i>99% BANDWIDTH.....</i>	<i>17</i>
7.3. <i>OUTPUT POWER.....</i>	<i>21</i>
7.4. <i>AVERAGE POWER.....</i>	<i>25</i>
7.5. <i>POWER SPECTRAL DENSITY .....</i>	<i>26</i>
7.6. <i>CONDUCTED SPURIOUS EMISSIONS.....</i>	<i>30</i>
<b>8. RADIATED TEST RESULTS.....</b>	<b>37</b>
8.1. <i>LIMITS AND PROCEDURE.....</i>	<i>37</i>
8.2. <i>TRANSMITTER ABOVE 1 GHz.....</i>	<i>39</i>
8.3. <i>WORST-CASE BELOW 1 GHz.....</i>	<i>52</i>
<b>9. AC POWER LINE CONDUCTED EMISSIONS.....</b>	<b>54</b>

---

**10. SETUP PHOTOS .....59**

# 1. ATTESTATION OF TEST RESULTS

**COMPANY NAME:** SONY MOBILE COMMUNICATIONS, INC.  
**EUT DESCRIPTION:** Tablet with Bluetooth, DTS/UNII a/b/g/n/ac, ANT+ and NFC  
**SERIAL NUMBER:** CB5A20E0RY (Radiated), CB5A208FAY (Conducted)  
**DATE TESTED:** August 11-25, 2014

APPLICABLE STANDARDS	
STANDARD	TEST RESULTS
CFR 47 Part 15 Subpart C	Pass

UL Verification Services Inc. tested the above equipment in accordance with the requirements set forth in the above standards. All indications of Pass/Fail in this report are opinions expressed by UL Verification Services Inc. based on interpretations and/or observations of test results. Measurement Uncertainties were not taken into account and are published for informational purposes only. The test results show that the equipment tested is capable of demonstrating compliance with the requirements as documented in this report.

**Note:** The results documented in this report apply only to the tested sample, under the conditions and modes of operation as described herein. This document may not be altered or revised in any way unless done so by UL Verification Services Inc. and all revisions are duly noted in the revisions section. Any alteration of this document not carried out by UL Verification Services Inc. will constitute fraud and shall nullify the document. This report must not be used by the client to claim product certification, approval, or endorsement by NVLAP, NIST, any agency of the Federal Government, or any agency of any government.

Approved & Released For  
UL Verification Services Inc. By:



DAN CORONIA  
CONSUMER TECHNOLOGY DIVISION  
PROJECT LEAD  
UL Verification Services Inc.

Tested By:



DANIEL SOPER  
CONSUMER TECHNOLOGY DIVISION  
LAB ENGINEER  
UL Verification Services Inc.

## 2. TEST METHODOLOGY

The tests documented in this report were performed in accordance with ANSI C63.10-2009, FCC CFR 47 Part 2, FCC CFR 47 Part 15.

## 3. FACILITIES AND ACCREDITATION

The test sites and measurement facilities used to collect data are located at 47173 Benicia Street, Fremont, California, USA.

47173 Benicia Street	47266 Benicia Street
<input type="checkbox"/> Chamber A	<input type="checkbox"/> Chamber D
<input checked="" type="checkbox"/> Chamber B	<input type="checkbox"/> Chamber E
<input checked="" type="checkbox"/> Chamber C	<input type="checkbox"/> Chamber F

UL Verification Services Inc. is accredited by NVLAP, Laboratory Code 200065-0. The full scope of accreditation can be viewed at <http://www.ccsemc.com>.

## 4. CALIBRATION AND UNCERTAINTY

### 4.1. MEASURING INSTRUMENT CALIBRATION

The measuring equipment utilized to perform the tests documented in this report has been calibrated in accordance with the manufacturer's recommendations, and is traceable to recognized national standards.

### 4.2. SAMPLE CALCULATION

Where relevant, the following sample calculation is provided:

$$\begin{aligned} \text{Field Strength (dBuV/m)} &= \text{Measured Voltage (dBuV)} + \text{Antenna Factor (dB/m)} + \text{Cable} \\ &\text{Loss (dB)} - \text{Preamp Gain (dB)} \\ 36.5 \text{ dBuV} + 18.7 \text{ dB/m} + 0.6 \text{ dB} - 26.9 \text{ dB} &= 28.9 \text{ dBuV/m} \end{aligned}$$

### 4.3. MEASUREMENT UNCERTAINTY

Where relevant, the following measurement uncertainty levels have been estimated for tests performed on the apparatus:

PARAMETER	UNCERTAINTY
Conducted Disturbance, 0.15 to 30 MHz	3.52 dB
Radiated Disturbance, 30 to 26000 MHz	4.94 dB

Uncertainty figures are valid to a confidence level of 95%.

## 5. EQUIPMENT UNDER TEST

### 5.1. DESCRIPTION OF EUT

The EUT is a Tablet with Bluetooth, DTS/UNII a/b/g/n/ac, ANT+ and NFC.

### 5.2. MAXIMUM OUTPUT POWER

The transmitter has a maximum peak conducted output power as follows:

Frequency Range (MHz)	Mode	Output Power (dBm)	Output Power (mW)
2402-2480	BLE	-0.40	0.91

### 5.3. DESCRIPTION OF AVAILABLE ANTENNAS

The radio utilizes an FPCB antenna, with a maximum gain of 0.4 dBi.

### 5.4. WORST-CASE CONFIGURATION AND MODE

Radiated emission and power line conducted emission were performed with the EUT set to transmit at the channel with highest output power as worst-case scenario.

The fundamental of the EUT was investigated in three orthogonal orientations X, Y, Z it was determined that X orientation was worst-case orientation; therefore, all final radiated testing was performed with the EUT in X orientation.



## 5.5. DESCRIPTION OF TEST SETUP

### SUPPORT EQUIPMENT

Support Equipment List				
Description	Manufacturer	Model	Serial Number	FCC ID
AC Adapter	Sony	EP880	3514W01 S08489 SEM 060	DoC
Earphone	Sony	MH410c	14071EB60060A84	DoC
MHL cable	Sony	N/A	N/A	N/A

### I/O CABLES

I/O Cable List						
Cable No	Port	# of identical ports	Connector Type	Cable Type	Cable Length (m)	Remarks
1	DC Power	1	Mini-USB	Shielded	1.2m	N/A
2	Audio	1	Mini-Jack	Unshielded	1m	N/A

### TEST SETUP

The EUT is continuously communicating to the Bluetooth tester during the tests.

**SETUP DIAGRAM FOR TESTS**

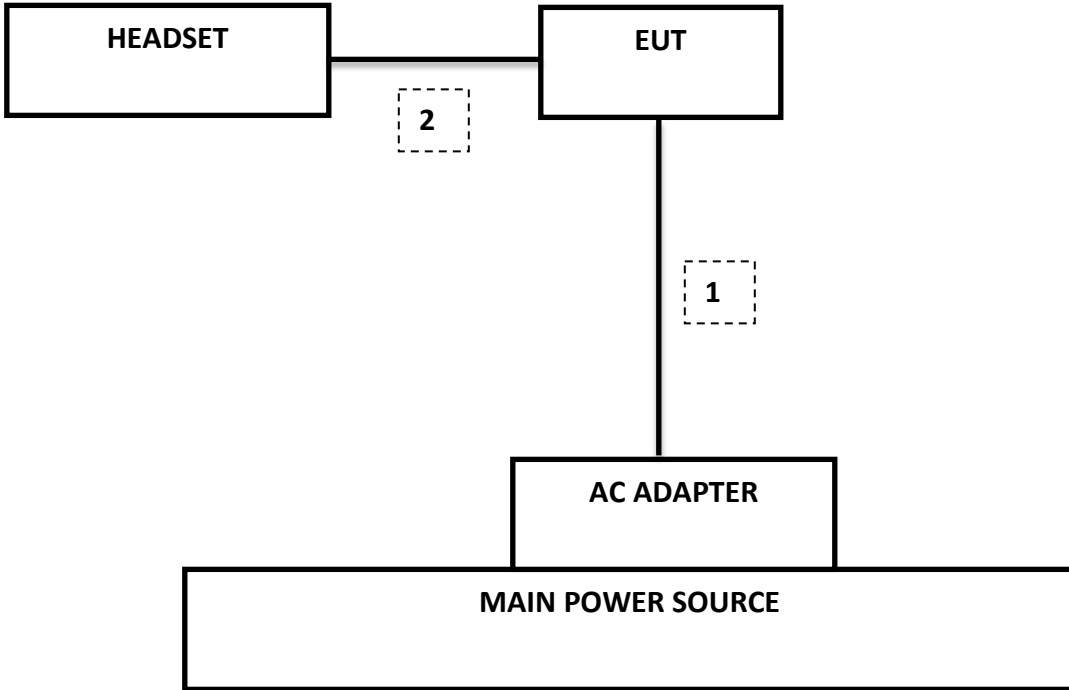

## 6. TEST AND MEASUREMENT EQUIPMENT

The following test and measurement equipment was utilized for the tests documented in this report:

Test Equipment List					
Description	Manufacturer	Model	Asset	Cal Date	Cal Due
Antenna, Biconolog, 30MHz-100MHz	Sunol Sciences	JB1	C01171	03/23/13	02/13/15
Antenna, Horn, 18GHz	EMCO	3115	C00783	10/25/13	10/25/14
Antenna, Horn, 25.5 GHz	ARA	MWH-1826/B	C00980	11/14/13	11/14/14
Preamplifier, 1300 MHz	Agilent / HP	8447D	C00580	01/28/13	01/28/15
Preamplifier, 26.5 GHz	Agilent / HP	8449B	C01052	10/22/13	10/22/14
Spectrum Analyzer, 44 GHz	Agilent / HP	E4446A	C01069	12/20/13	12/20/14
CBT Bluetooth Tester	R & S	CBT	None	07/12/13	07/12/15
Peak Power Meter	Agilent / HP	E4416A	C00963	12/13/13	12/13/14
Peak / Average Power Sensor	Agilent / HP	E9327A	C00964	12/13/13	12/13/14
LISN, 30 MHz	FCC	50/250-25-2	C00626	01/14/13	01/14/15
Reject Filter, 2.4GHz	Micro-Tronics	BRM50702	N02684	CNR	CNR

## 7. SUMMARY TABLE

The FCC ID: PY7TS-0040 shares the same enclosure and circuit board as FCC ID: PY7TM-0050. The BLE circuitry and layout, including antennas, are almost identical between the two units. The BLE antennas and surrounding circuitry are the same between these two units. The main difference between the two models is that WWAN circuitry in FCC ID: PY7TM-0050 is removed for FCC ID: FCC ID: PY7TS-0040.

After confirming through preliminary radiated emissions that the performance of the FCC ID: PY7TS-0040 remains representative of FCC ID: PY7TM-0050, test data for FCC ID: PY7TM-0050 is being submitted for this application to cover BLE features.

Radiated emissions were fully re-evaluated against FCC Part 15B requirements for digital devices and results indicated no significant differences between the two versions due to the depopulation of the WWAN circuitry.

FCC Part Section	RSS Section(s)	Test Description	Test Limit	Test Condition	Test Result	Worst Case
15.247 (a)(2)	RSS-210 A8.2(a)	Occupied Band width (6dB)	>500KHz	Conducted	Pass	0.72 MHz
2.1051, 15.247 (d)	RSS-210 A8.5	Band Edge / Conducted Spurious Emission	-20dBc		Pass	-45.53 dBm
15.247	RSS-210 A8.4	TX conducted output power	<30dBm		Pass	2.49 dBm
15.247	RSS-210 A8.2	PSD	<8dBm		Pass	-11.71 dBm
15.207 (a)	RSS-GEN 7.2.2	AC Power Line conducted emissions	Section 10	Radiated	Pass	12.53 dBuV(AV)
15.205, 15.209	RSS-210 Clause 2.6, RSS-210 Clause 6	Radiated Spurious Emission	< 54dBuV/m		Pass	42.94 dBuV/m

## ANTENNA PORT TEST RESULTS

### 7.1. 6 dB BANDWIDTH

#### LIMITS

FCC §15.247 (a) (2)

The minimum 6 dB bandwidth shall be at least 500 kHz.

#### TEST PROCEDURE

The transmitter output is connected to a spectrum analyzer. The RBW is set to 100 kHz and the VBW is set to 300 kHz. The sweep time is coupled.

#### RESULTS

Channel	Frequency (MHz)	6 dB Bandwidth (MHz)	Minimum Limit (MHz)
Low	2402	0.7200	0.5
Middle	2440	0.7240	0.5
High	2480	0.7330	0.5

**6 dB BANDWIDTH PLOTS**

**LOW CHANNEL**

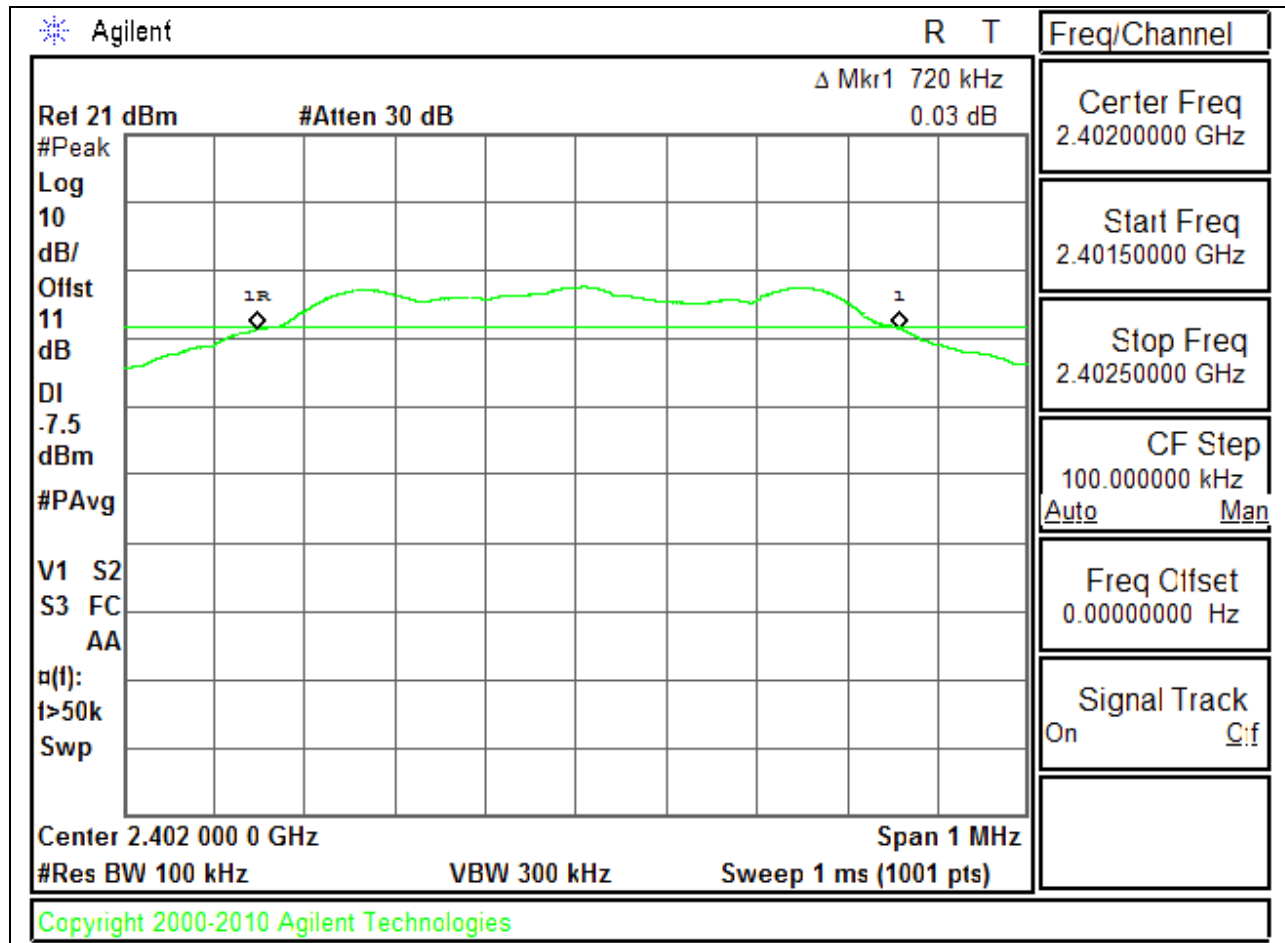

**MID CHANNEL**

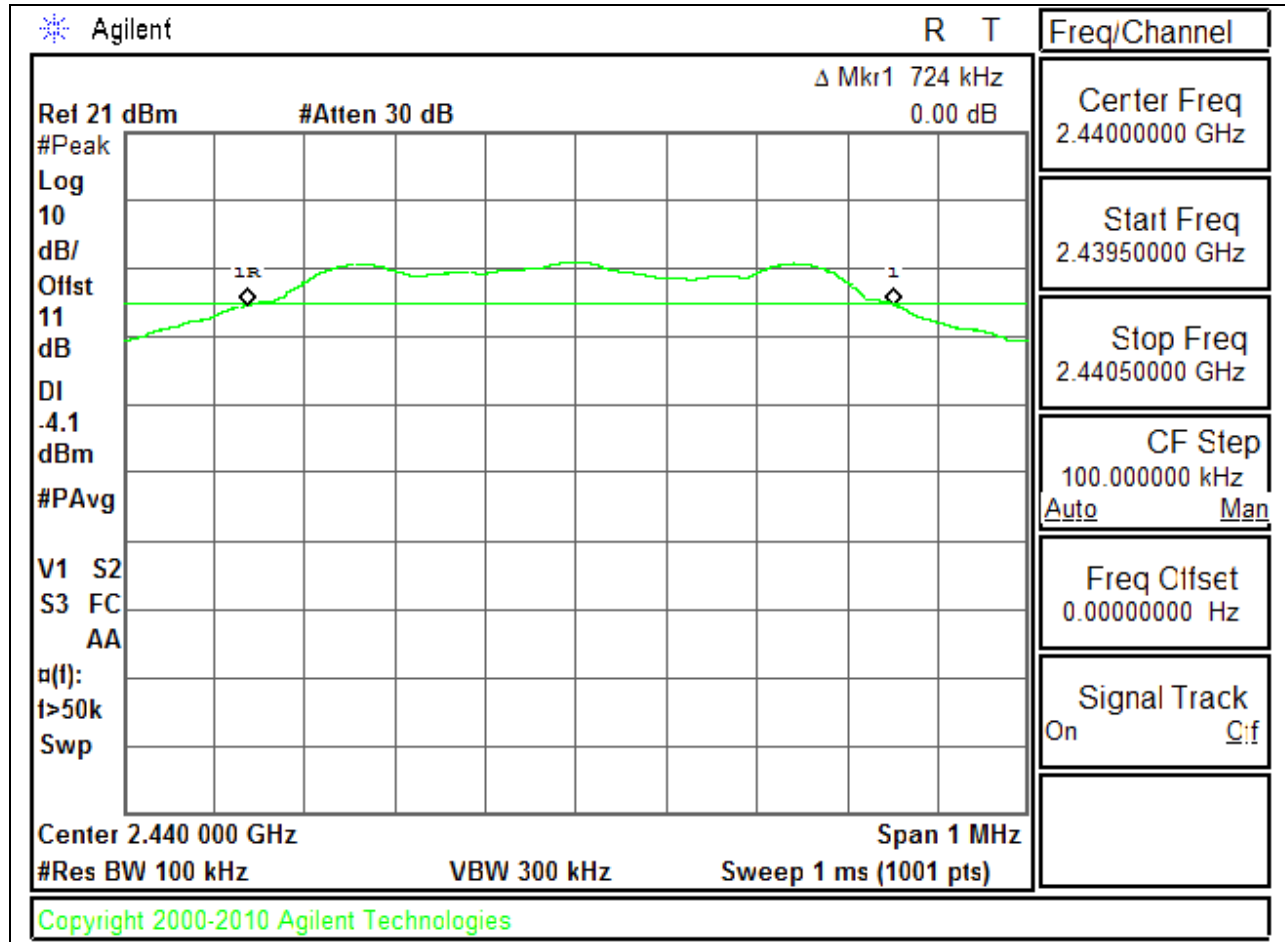

**HIGH CHANNEL**

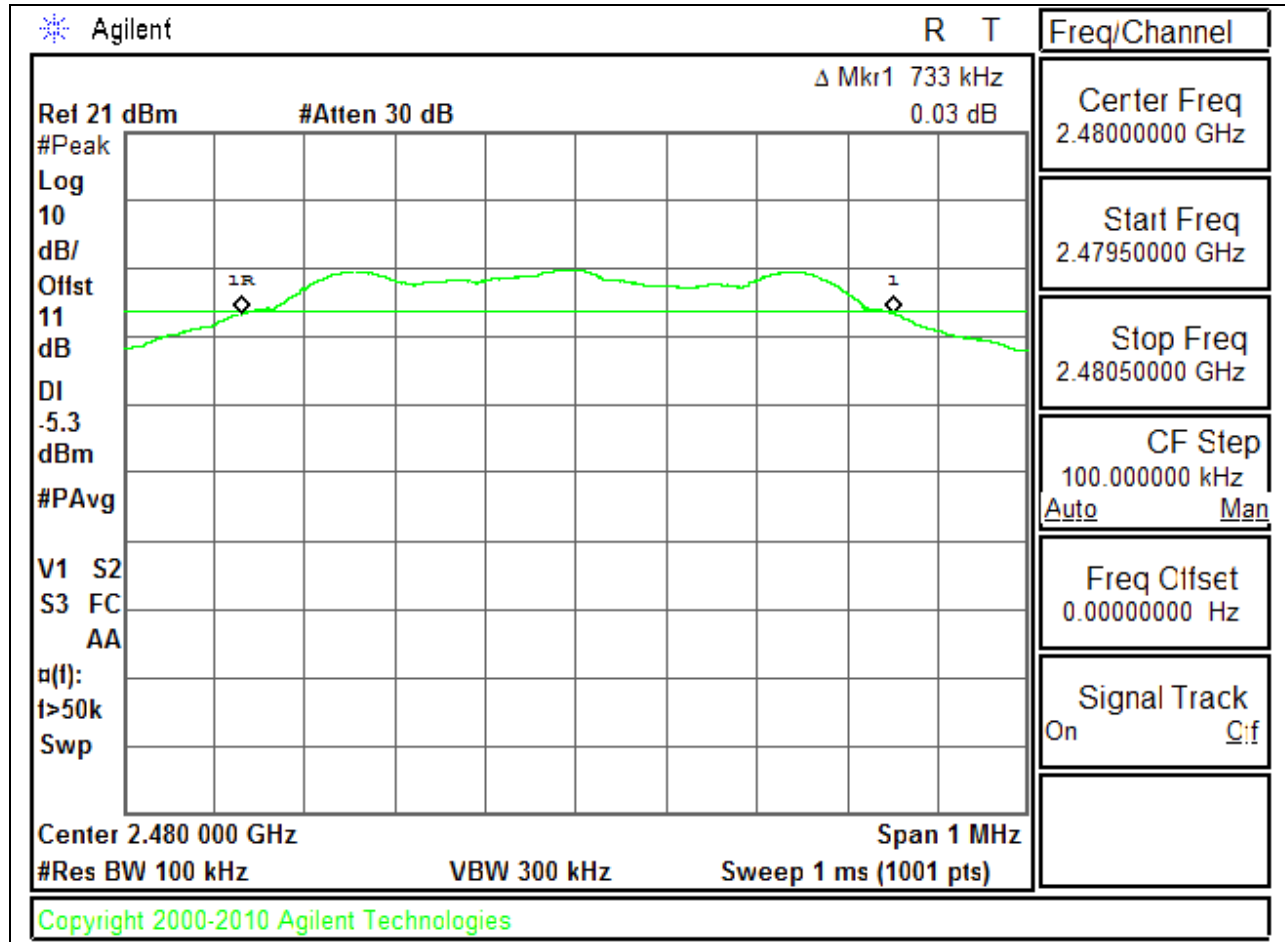



## 7.2. 99% BANDWIDTH

### LIMITS

None; for reporting purposes only.

### TEST PROCEDURE

Reference to KDB558074 D01 DTS Meas Guidance v03r02: The transmitter output is connected to the spectrum analyzer. The RBW is set to 1% to 3% of the 99 % bandwidth and to 1% of the span. The VBW is set to 3 times the RBW. The sweep time is coupled. The spectrum analyzer internal 99% bandwidth function is utilized.

### RESULTS

Channel	Frequency (MHz)	99% Bandwidth (MHz)
Low	2402	1.0500
Middle	2440	1.0400
High	2480	1.0500

**99% BANDWIDTH PLOTS**

**LOW CHANNEL**

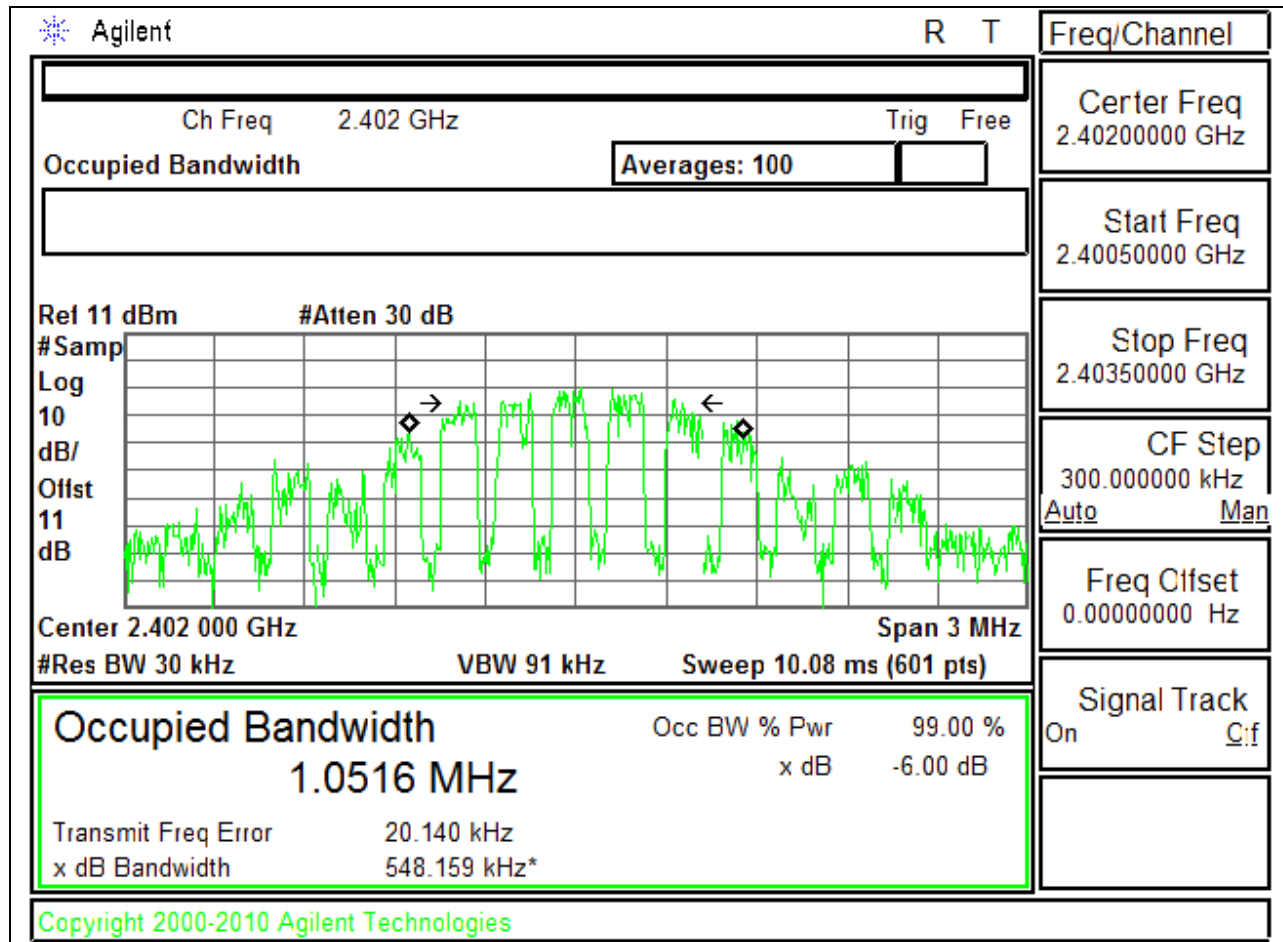

**MID CHANNEL**

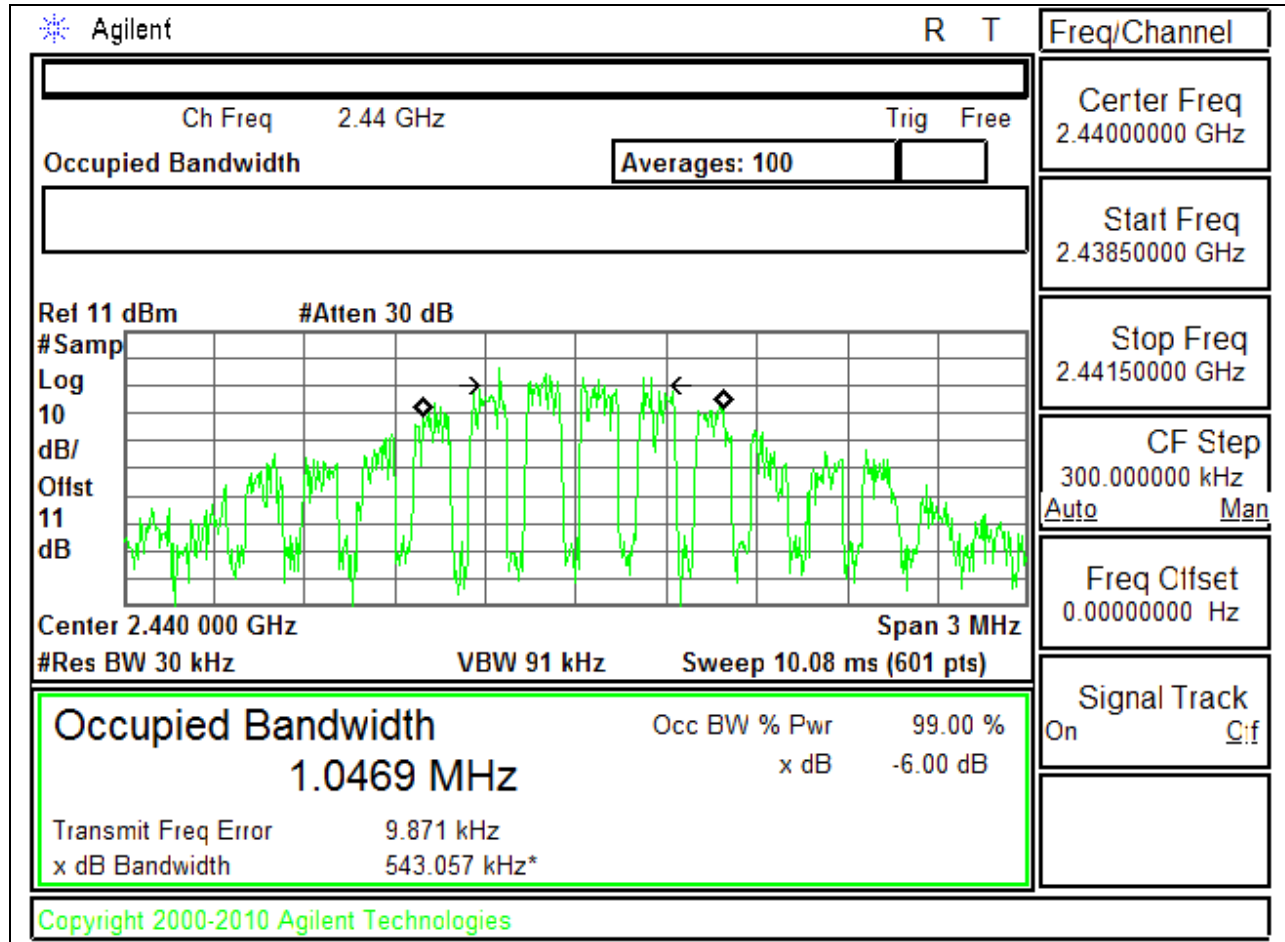

**HIGH CHANNEL**

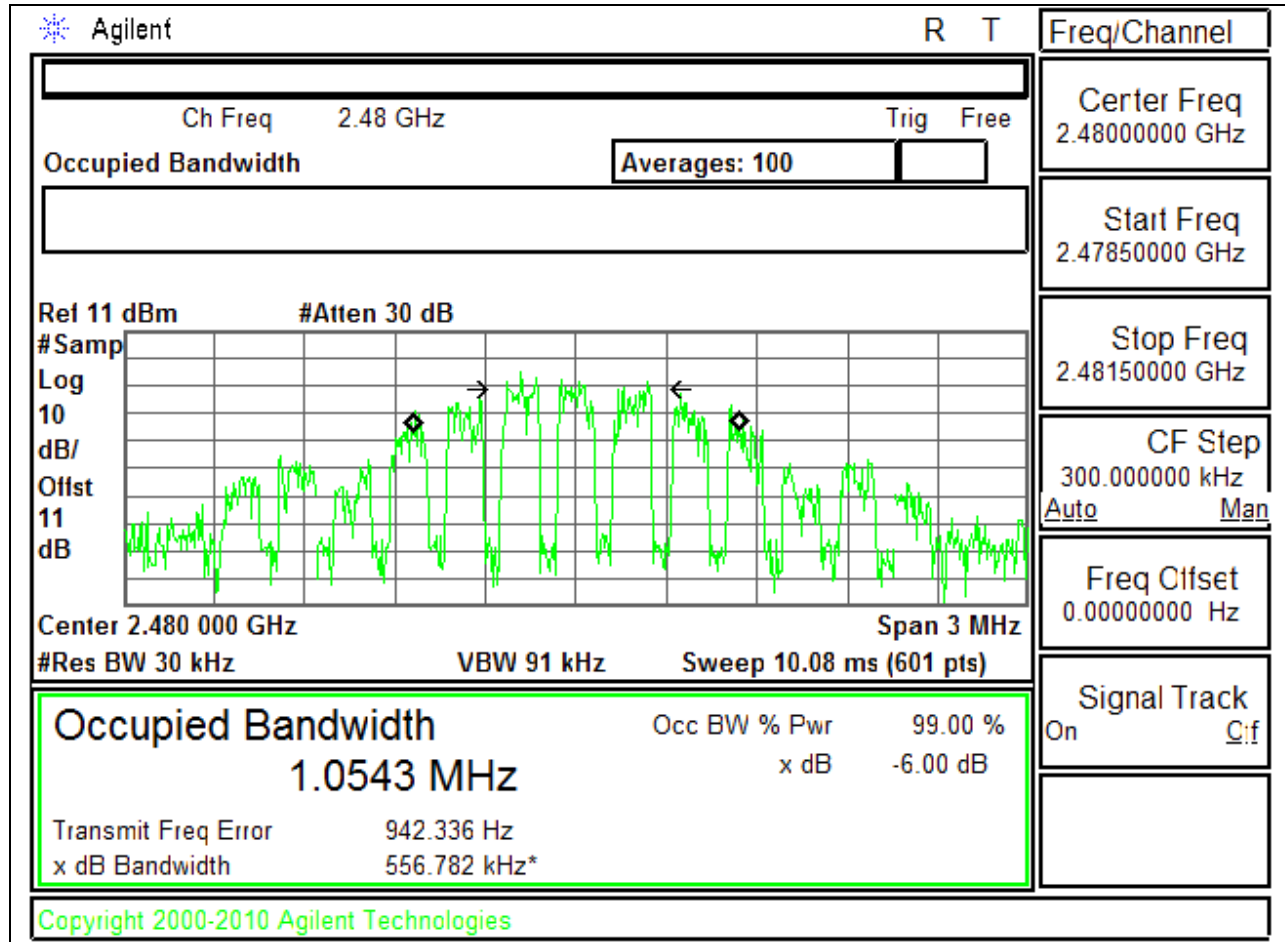

### 7.3. OUTPUT POWER

#### LIMITS

FCC §15.247 (b)

The maximum antenna gain is less than or equal to 6 dBi, therefore the limit is 30 dBm.

#### TEST PROCEDURE

Peak power is measured using KDB558074 D01 DTS Meas Guidance v03r02 under section 9.1.1 utilizing spectrum analyzer.

#### RESULTS

Channel	Frequency (MHz)	Peak Power Reading (dBm)	Limit (dBm)	Margin (dB)
Low	2402	-0.700	30	-30.700
Middle	2440	2.490	30	-27.510
High	2480	1.420	30	-28.580

**OUTPUT POWER PLOTS**

**LOW CHANNEL**

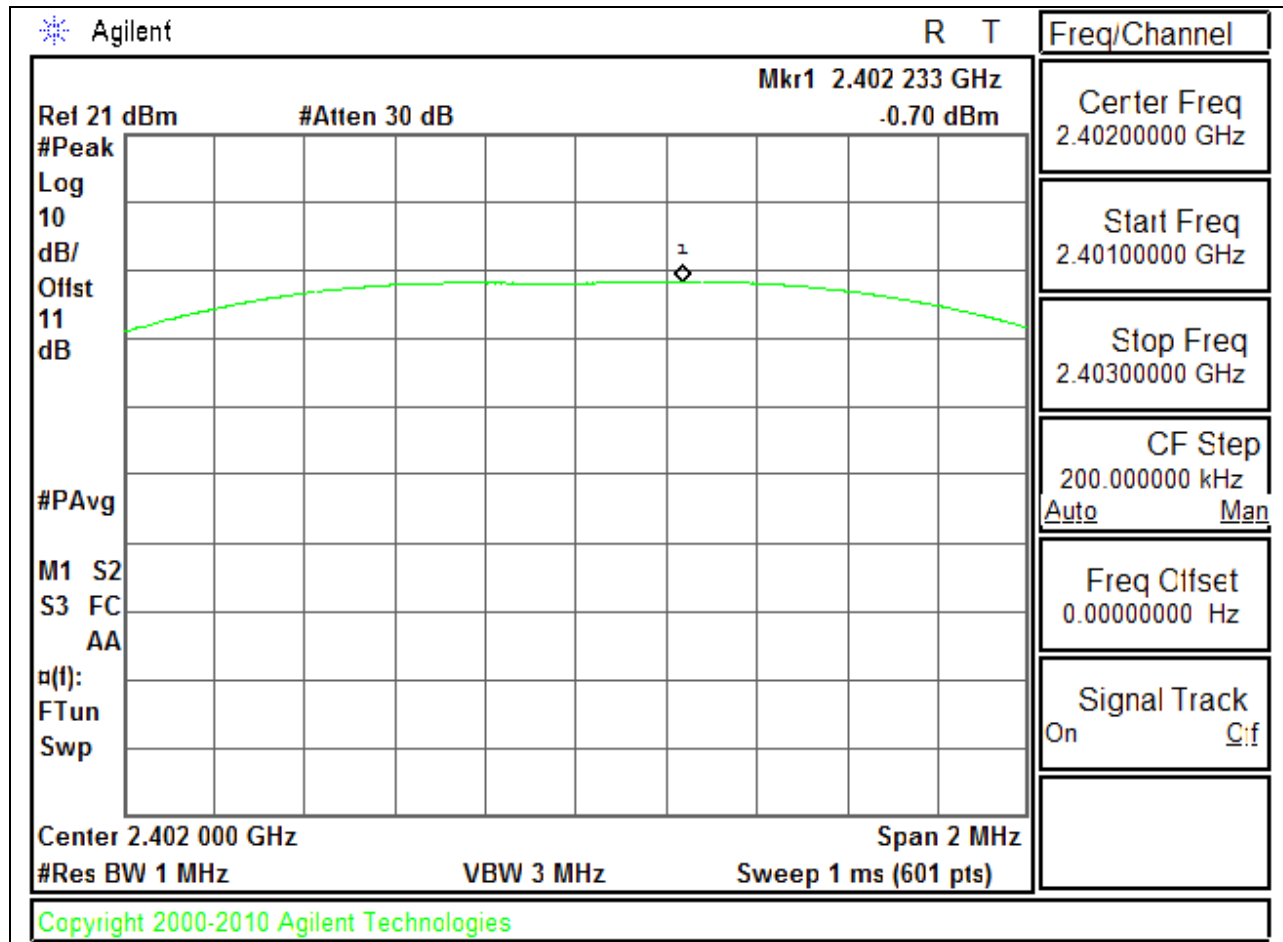

**MID CHANNEL**

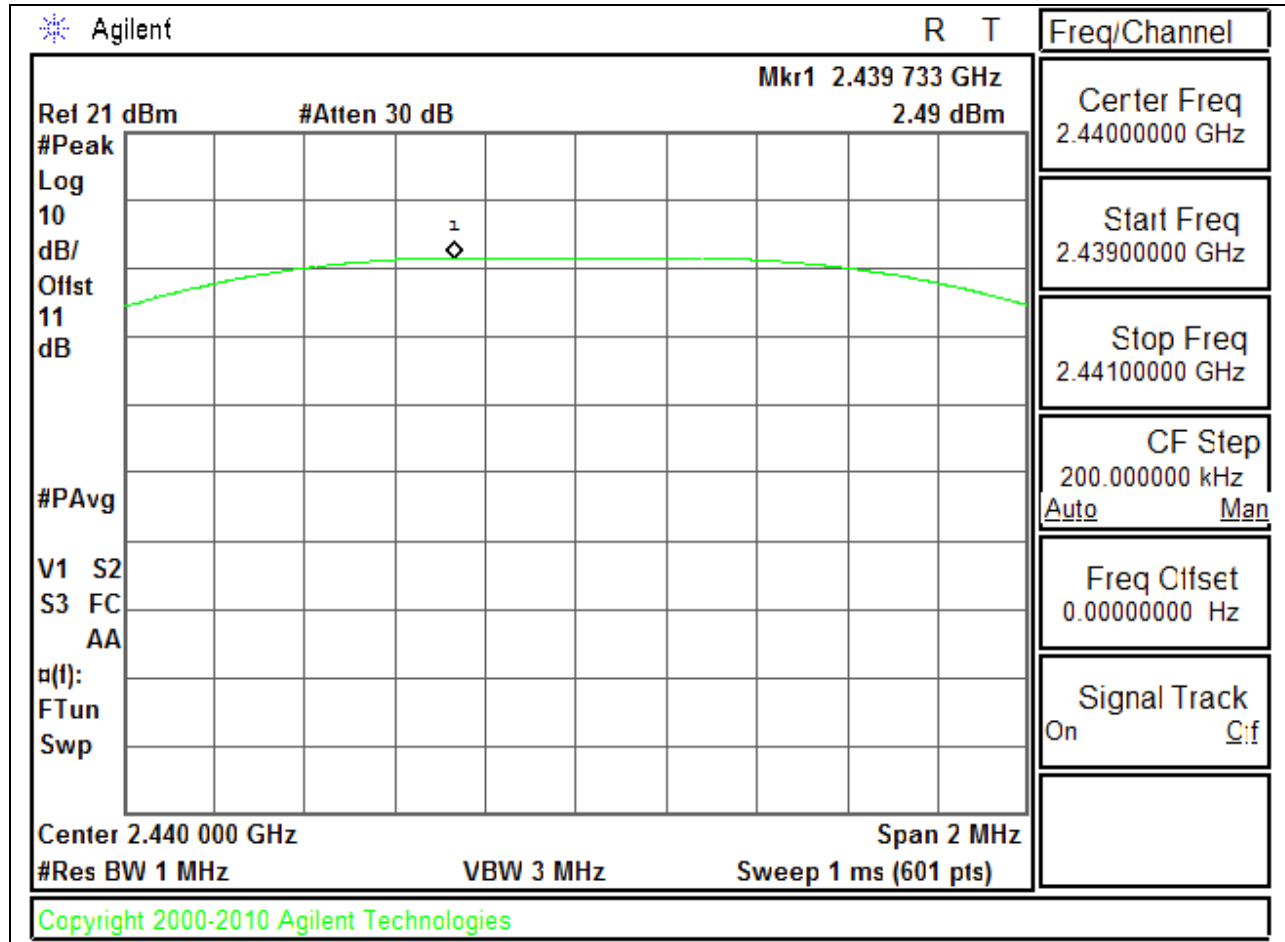

**HIGH CHANNEL**

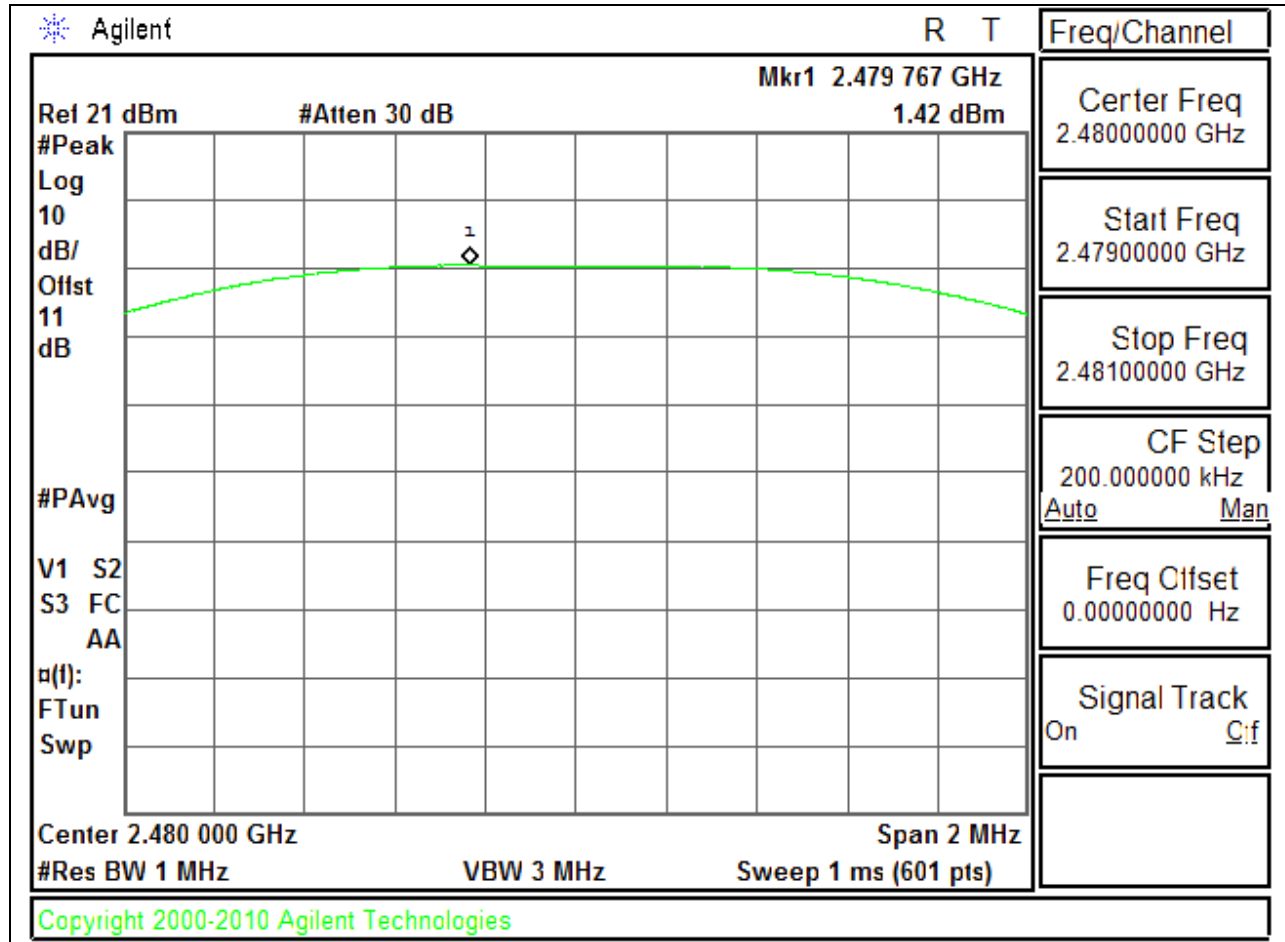



## 7.4. AVERAGE POWER

### LIMITS

None; for reporting purposes only.

### TEST PROCEDURE

The transmitter output is connected to a power meter.

### RESULTS

The cable assembly insertion loss of 11 dB (including 10 dB pad and 1 dB cable) was entered as an offset in the power meter to allow for direct reading of power.

Channel	Frequency (MHz)	AV power (dBm)
Low	2402	-3.9
Middle	2440	-0.4
High	2480	-1.6

## 7.5. POWER SPECTRAL DENSITY

### LIMITS

FCC §15.247 (e)

The power spectral density conducted from the transmitter to the antenna shall not be greater than 8 dBm in any 3 kHz band during any time interval of continuous transmission.

### TEST PROCEDURE

Power Spectral Density was performed utilizing the “Method PKPSD (Peak PSD)” under KDB558074 D01 DTS Meas Guidance v03r02

### RESULTS

Channel	Frequency (MHz)	PSD (dBm)	Limit (dBm)	Margin (dB)
Low	2402	-14.92	8	-22.92
Middle	2440	-11.71	8	-19.71
High	2480	-12.78	8	-20.78

**POWER SPECTRAL DENSITY PLOTS**

**LOW CHANNEL**

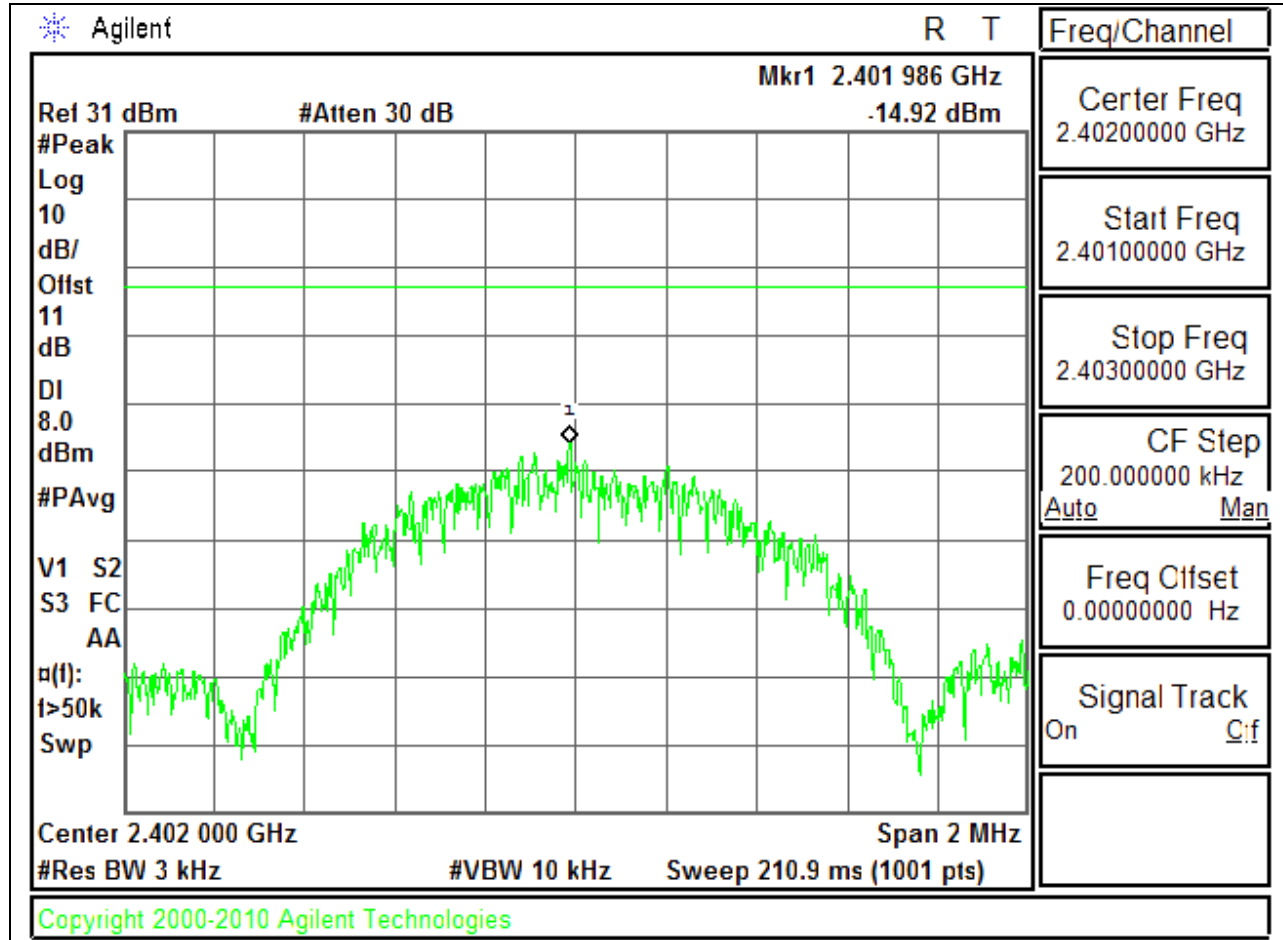

**MID CHANNEL**

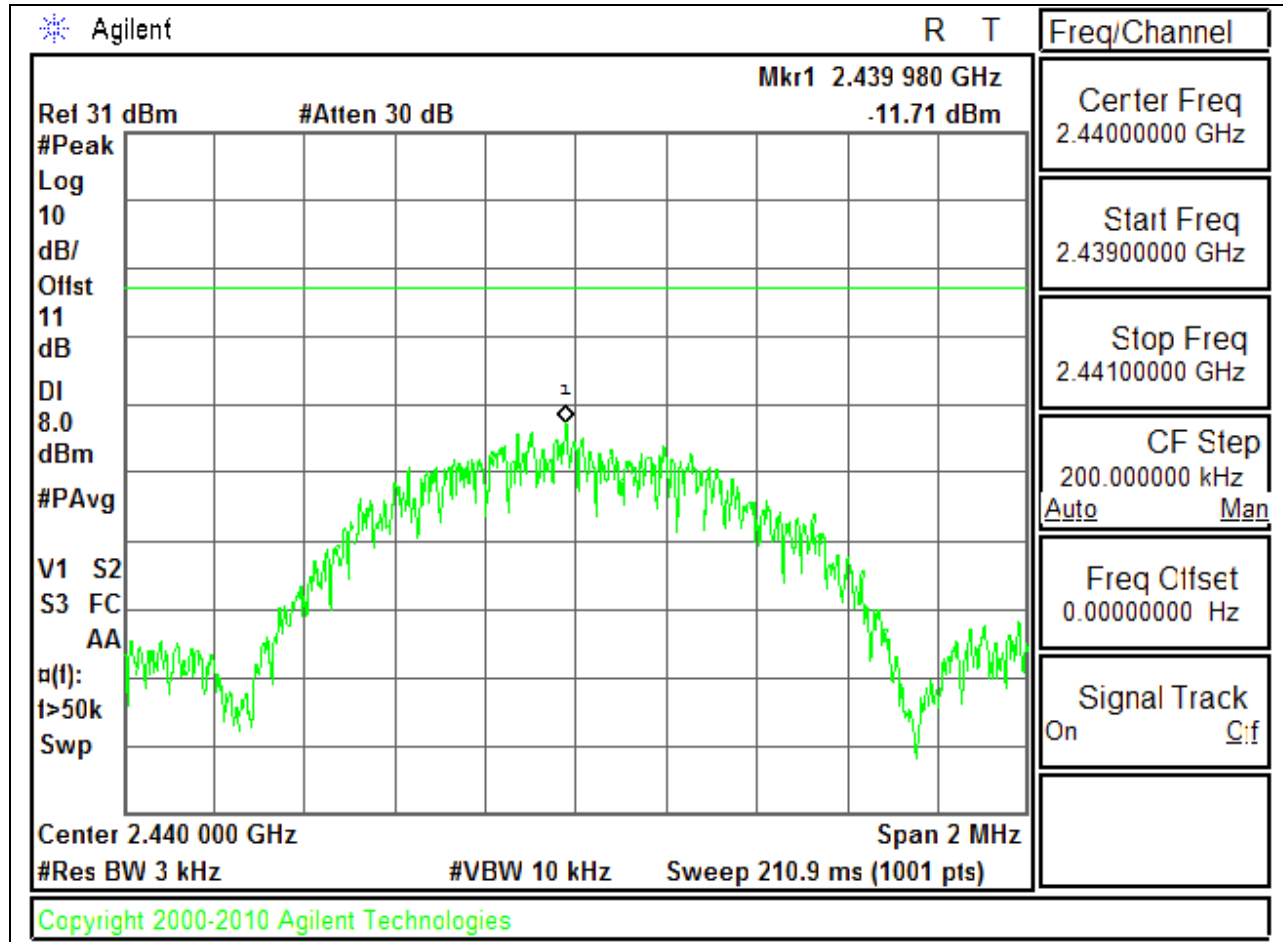

**HIGH CHANNEL**

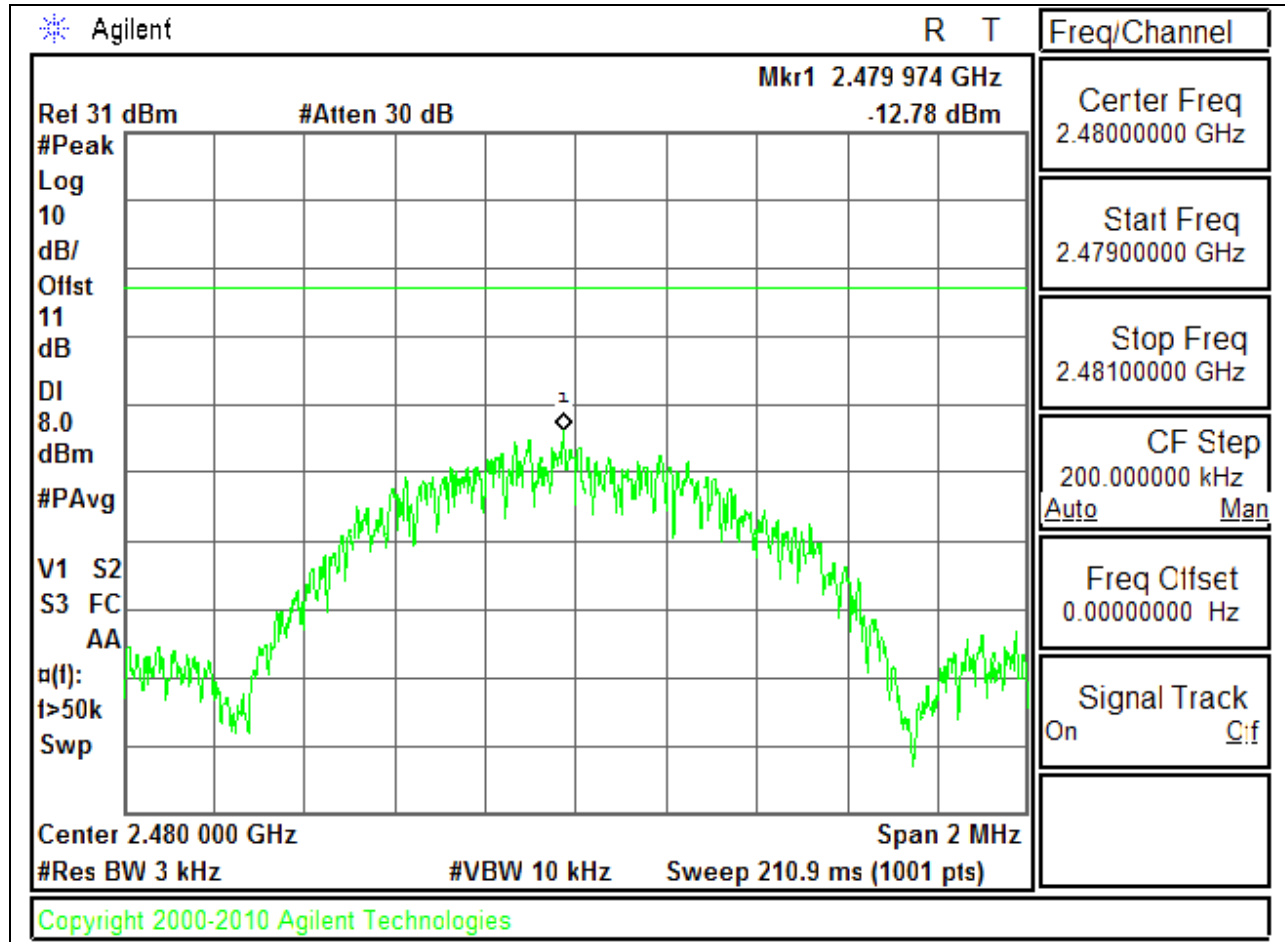

## **7.6. CONDUCTED SPURIOUS EMISSIONS**

### **LIMITS**

FCC §15.247 (d)

Output power was measured based on the use of a peak measurement, therefore the required attenuation is 20 dB.

### **TEST PROCEDURE**

The transmitter output is connected to a spectrum analyzer. The resolution bandwidth is set to 100 kHz. The video bandwidth is set to 300 kHz.

The spectrum from 30 MHz to 26 GHz is investigated with the transmitter set to the lowest, middle, and highest channels.

**RESULTS**

**SPURIOUS EMISSIONS, LOW CHANNEL**

**LOW CHANNEL BANDEDGE**

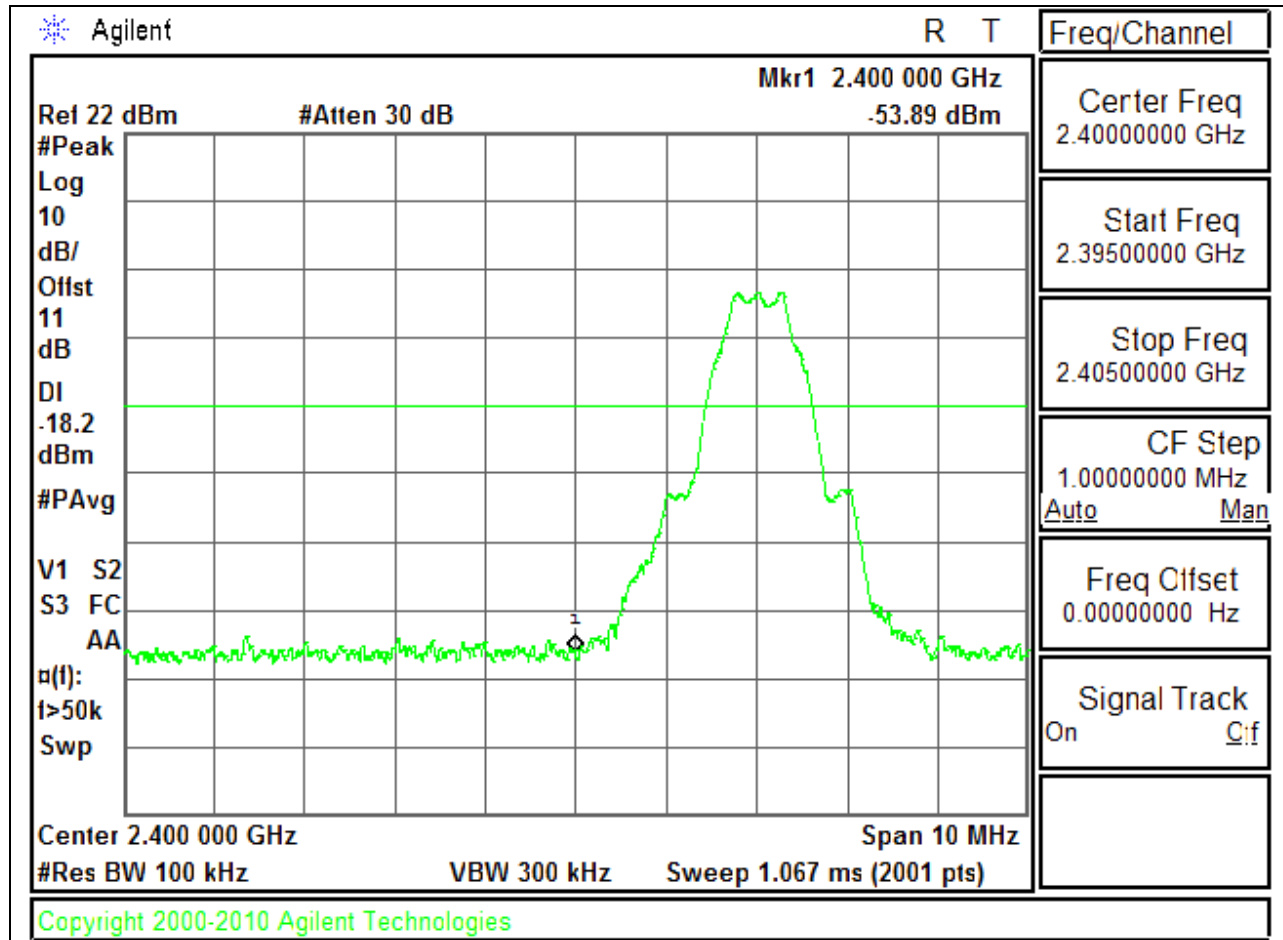

**LOW CHANNEL SPURIOUS**

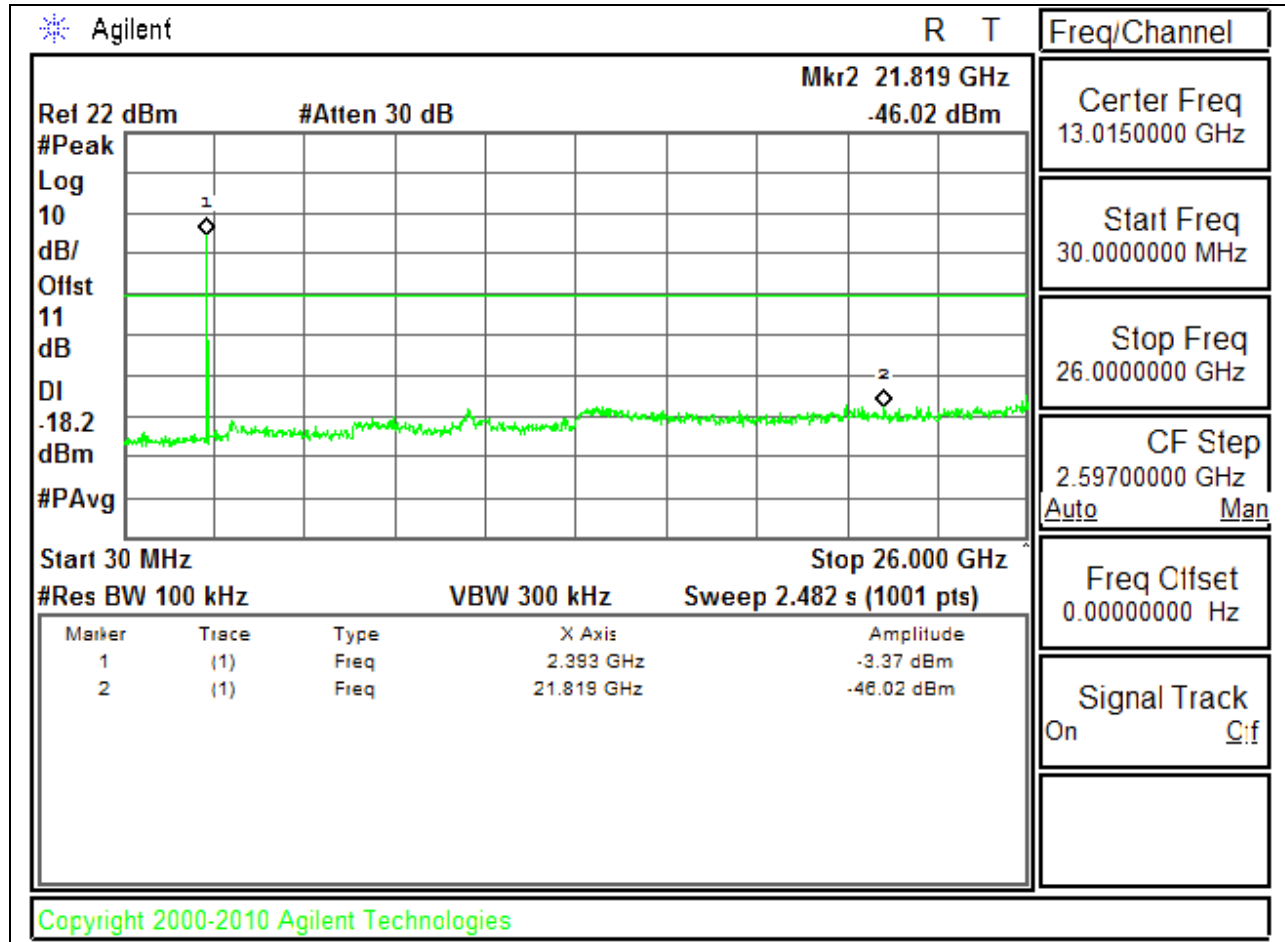



**SPURIOUS EMISSIONS, MID CHANNEL**

**MID CHANNEL REFERENCE**

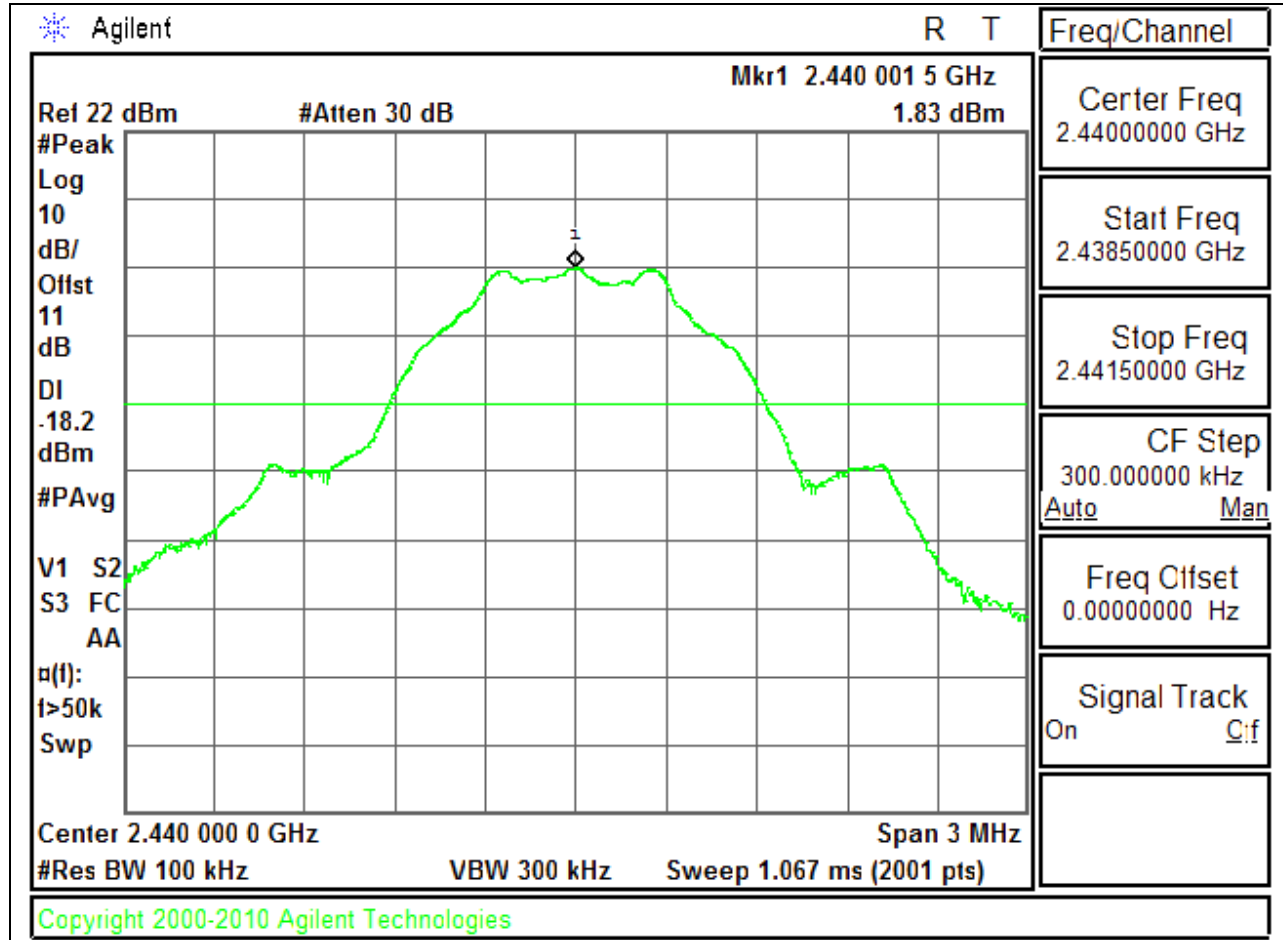

**MID CHANNEL SPURIOUS**

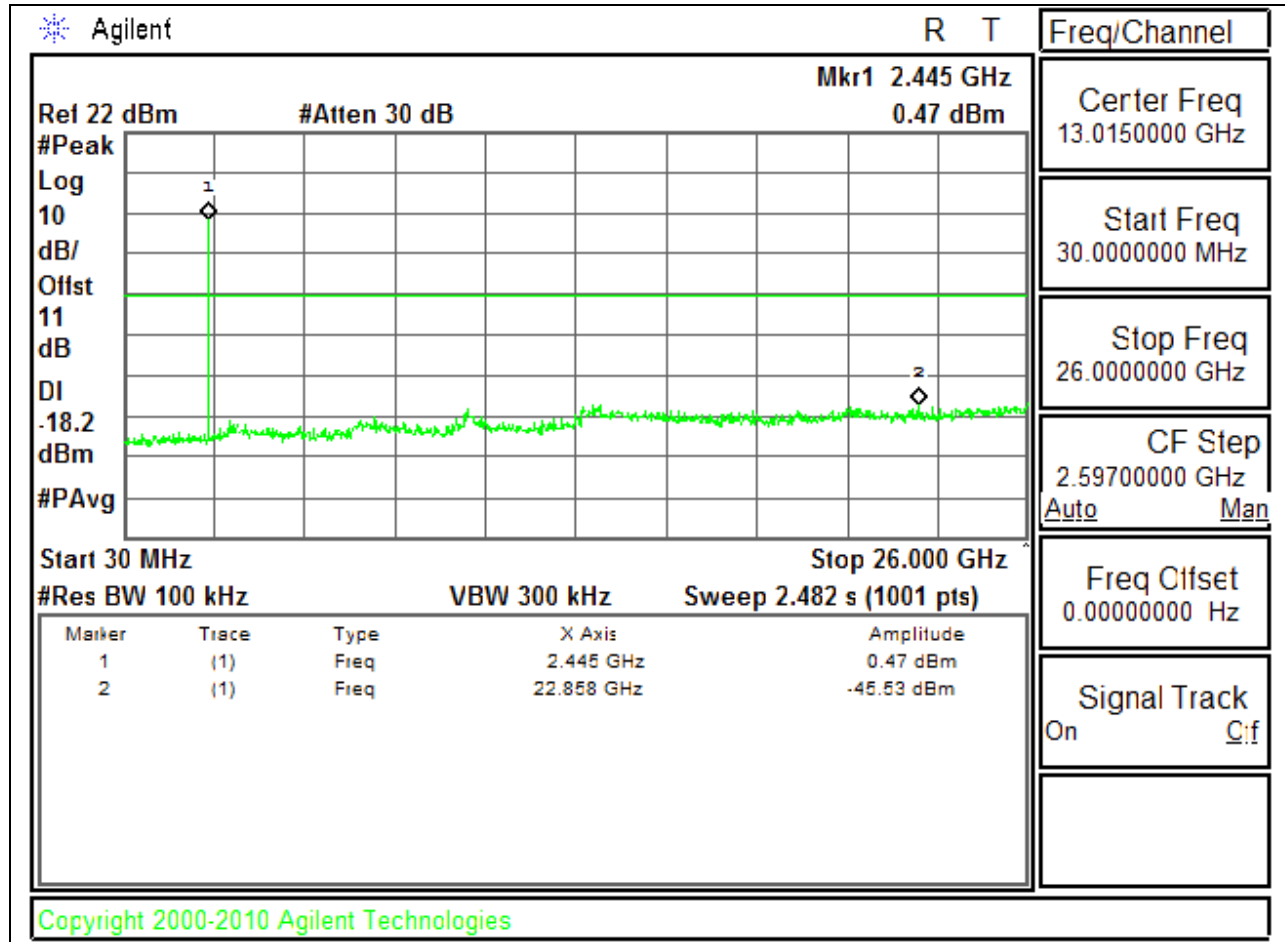

**SPURIOUS EMISSIONS, HIGH CHANNEL**

**HIGH CHANNEL BANDEDGE**

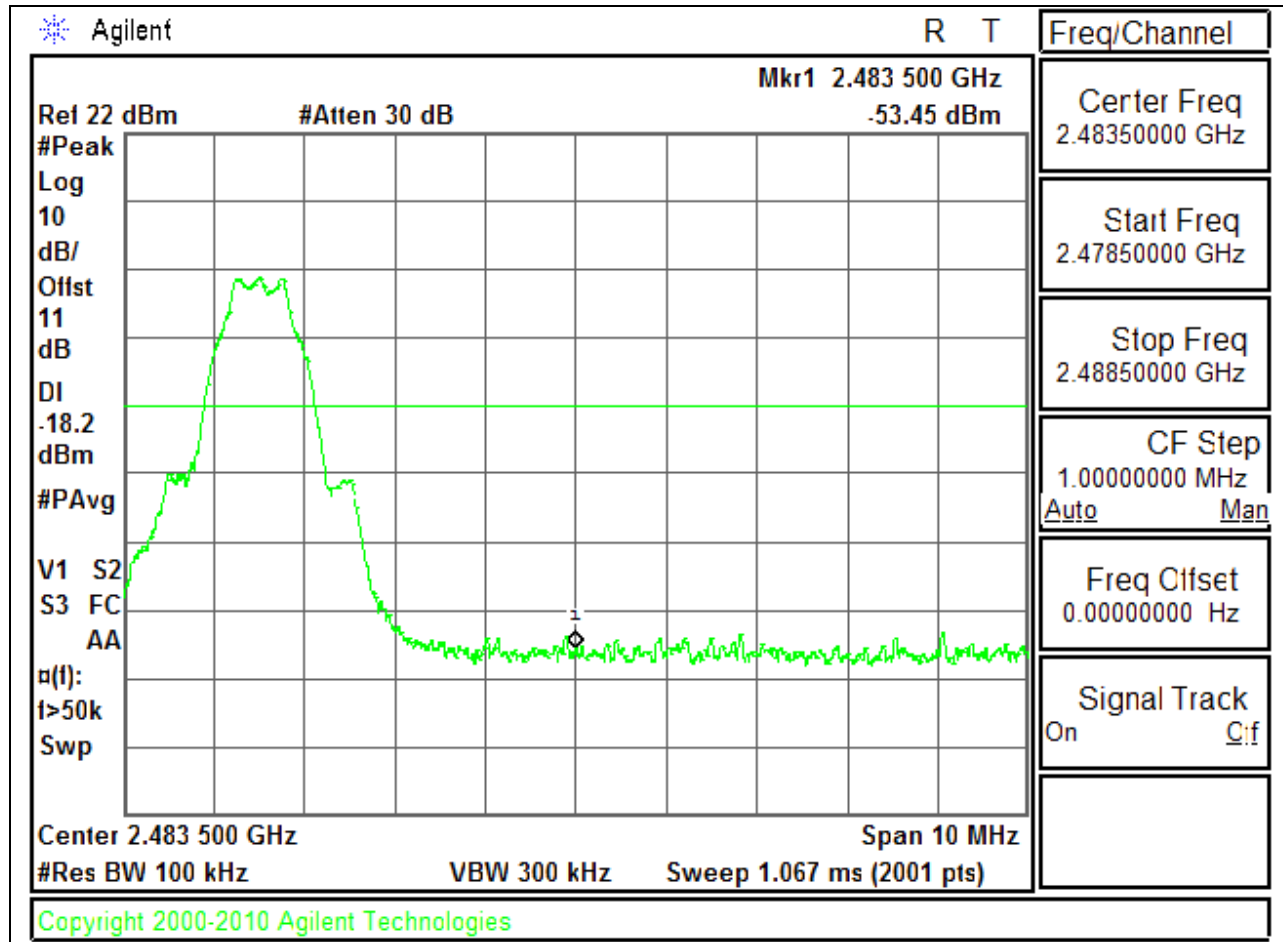

### HIGH CHANNEL SPURIOUS

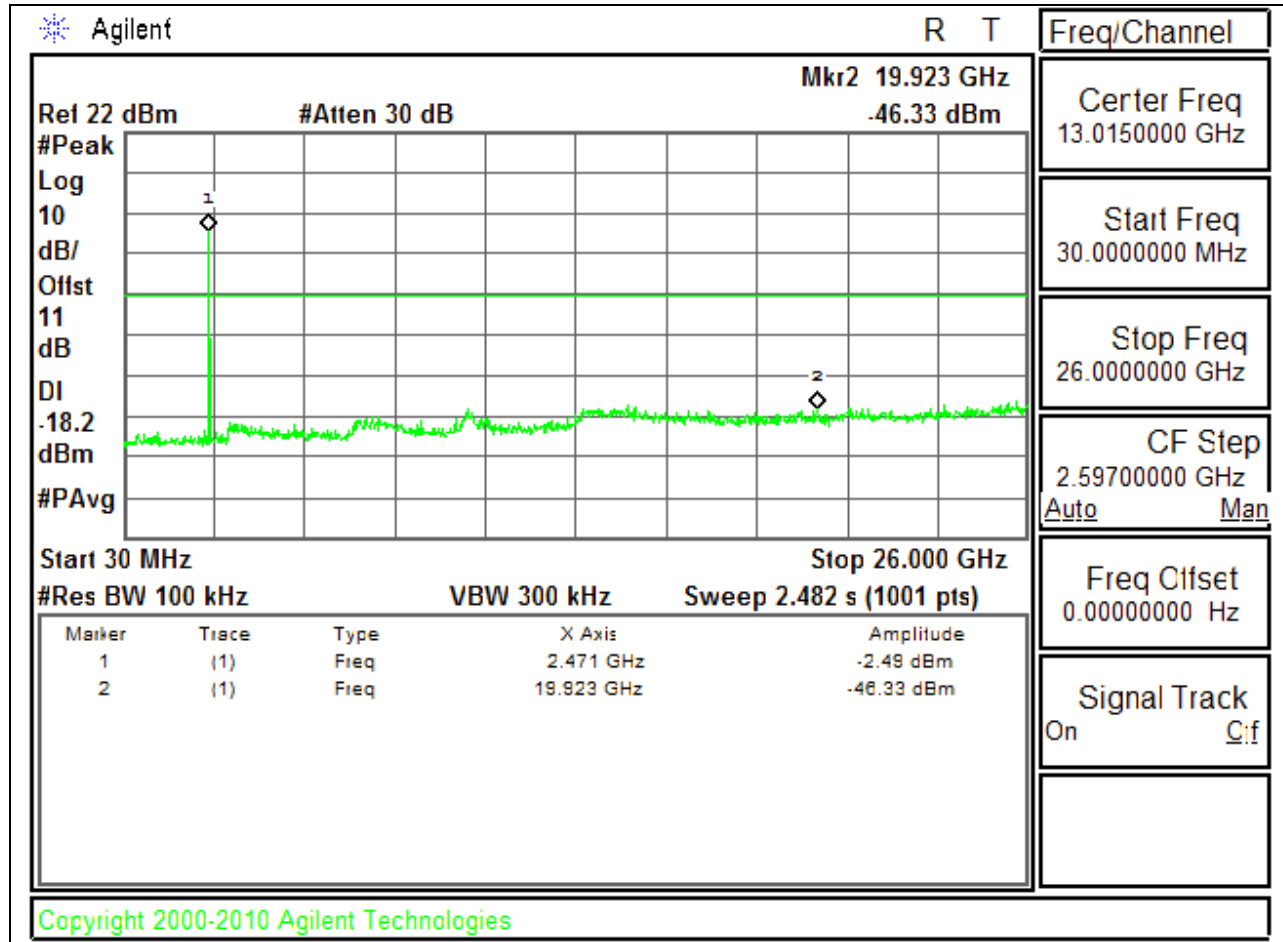

## 8. RADIATED TEST RESULTS

### 8.1. LIMITS AND PROCEDURE

#### LIMITS

FCC §15.205 and §15.209

Frequency Range (MHz)	Field Strength Limit ( $\mu\text{V}/\text{m}$ ) at 3 m	Field Strength Limit (dB $\mu\text{V}/\text{m}$ ) at 3 m
30 - 88	100	40
88 - 216	150	43.5
216 - 960	200	46
Above 960	500	54

## **TEST PROCEDURE**

The EUT is placed on a non-conducting table 80 cm above the ground plane. The antenna to EUT distance is 3 meters. The EUT is configured in accordance with ANSI C63.4 - 2009. The EUT is set to transmit in a continuous mode.

For measurements below 1 GHz the resolution bandwidth is set to 100 kHz for peak detection measurements or 120 kHz for quasi-peak detection measurements. Peak detection is used unless otherwise noted as quasi-peak.

For measurements above 1 GHz the resolution bandwidth is set to 1 MHz, then the video bandwidth is set to 1 MHz for peak measurements and add duty cycle factor for average measurements. Duty cycle factor =  $10 \log (1/x)$ . For this sample: DCF =  $10 \log (1/0.624) = 2.1 \text{ dB}$

The spectrum from 30 MHz to 26 GHz is investigated with the transmitter set to the lowest, middle, and highest channels in the 2.4 GHz band.

The spectrum from 30 MHz to 40 GHz is investigated with the transmitter set to the lowest, middle, and highest channels in each applicable band.

The frequency range of interest is monitored at a fixed antenna height and EUT azimuth. The EUT is rotated through 360 degrees to maximize emissions received. The antenna is scanned from 1 to 4 meters above the ground plane to further maximize the emission. Measurements are made with the antenna polarized in both the vertical and the horizontal positions.

## 8.2. TRANSMITTER ABOVE 1 GHz RESTRICTED BANDEDGE (LOW CHANNEL)

### HORIZONTAL PEAK AND AVERAGE PLOT

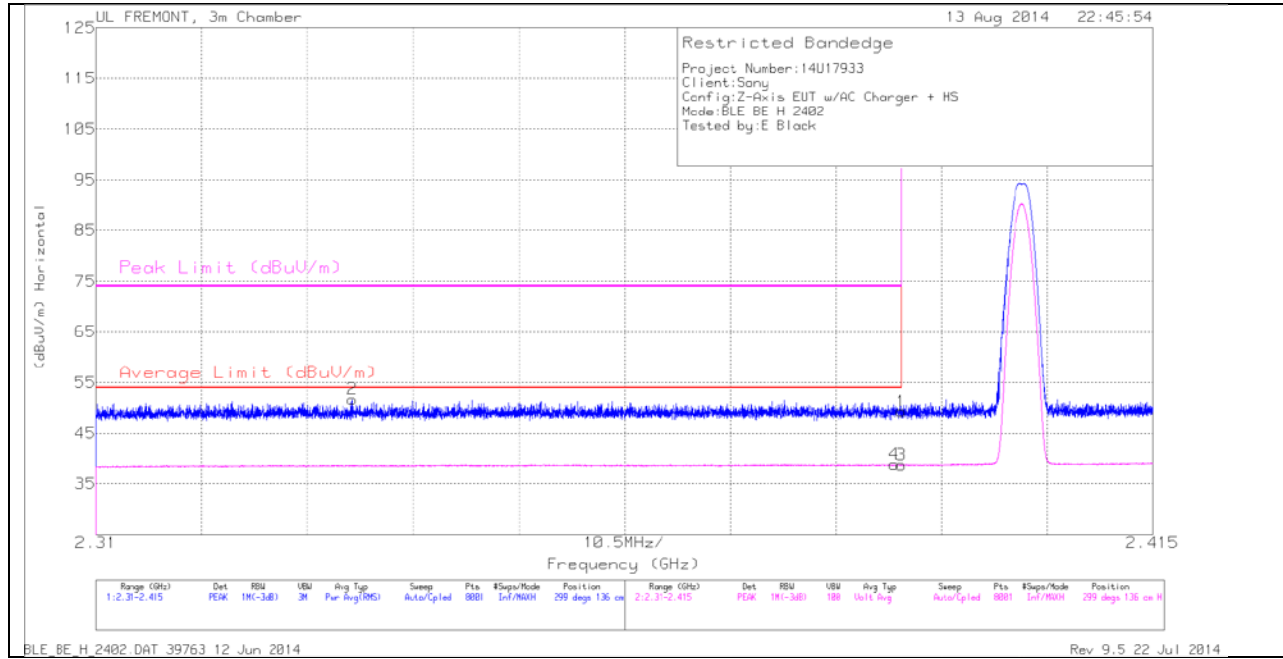

### HORIZONTAL DATA

Marker	Frequency (GHz)	Meter Reading (dBuV)	Det	AF T119 (dB/m)	Amp/Cb/Fitter/Pad (dB)	DC Corr (dB)	Corrected Reading (dBuV/m)	Average Limit (dBuV/m)	Margin (dB)	Peak Limit (dBuV/m)	PK Margin (dB)	Azimuth (Degs)	Height (cm)	Polarity
2	2.336	42.92	PK	31.9	-23.1	0	51.72	-	-	74	-22.28	299	136	H
4	2.389	29.85	RMS	32.1	-23.1	2.1	38.85	54	-15.15	-	-	299	136	H
1	2.39	40.33	PK	32.1	-23.1	0	49.33	-	-	74	-24.67	299	136	H
3	2.39	29.69	RMS	32.1	-23.1	2.1	38.69	54	-15.31	-	-	299	136	H

**VERTICAL PEAK AND AVERAGE PLOT**

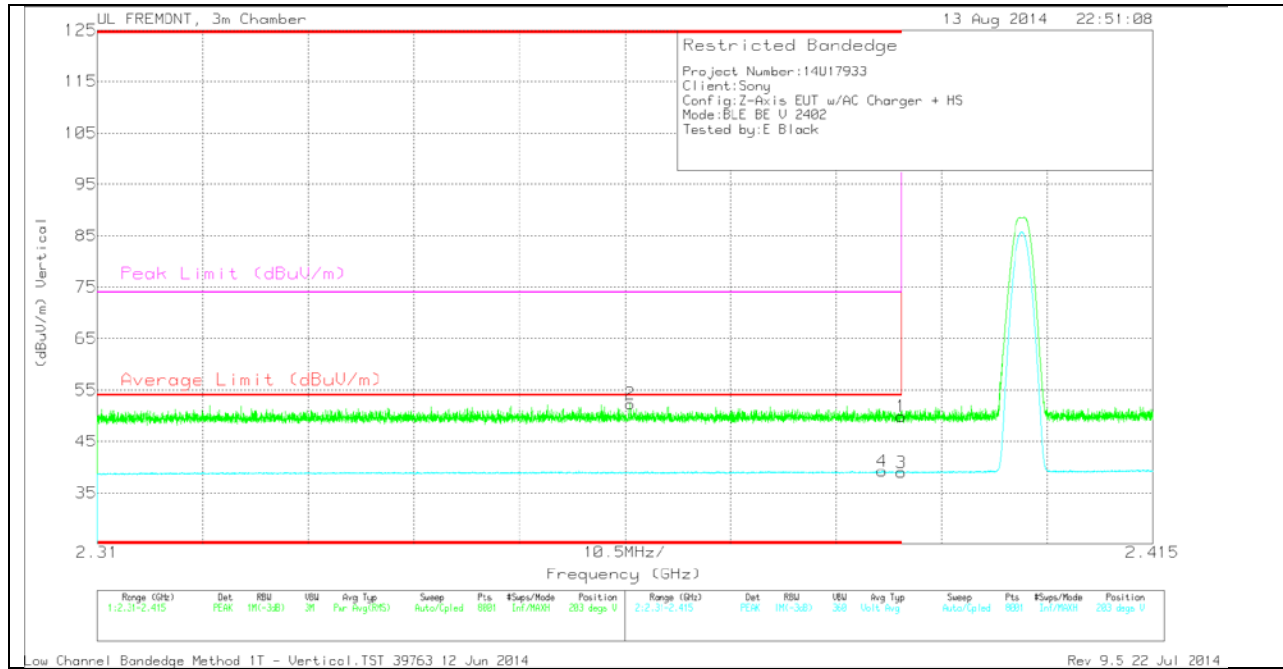

**VERTICAL DATA**

Marker	Frequency (GHz)	Meter Reading (dBuV)	Det	AF T119 (dB/m)	Amp/Cb/Filter/Pad (dB)	DC Corr (dB)	Corrected Reading (dBuV/m)	Average Limit (dBuV/m)	Margin (dB)	Peak Limit (dBuV/m)	PK Margin (dB)	Azimuth (Degs)	Height (cm)	Polarity
2	* 2.363	43.43	PK	32	-23.1	0	52.33	-	-	74	-21.67	203	154	V
4	* 2.388	30.19	RMS	32.1	-23.1	2.1	39.19	54	-14.81	-	-	203	154	V
1	* 2.39	40.87	PK	32.1	-23.1	0	49.87	-	-	74	-24.13	203	154	V
3	* 2.39	29.95	RMS	32.1	-23.1	2.1	38.95	54	-15.05	-	-	203	154	V



**AUTHORIZED BANDEDGE (HIGH CHANNEL)**

**HORIZONTAL PEAK AND AVERAGE PLOT**

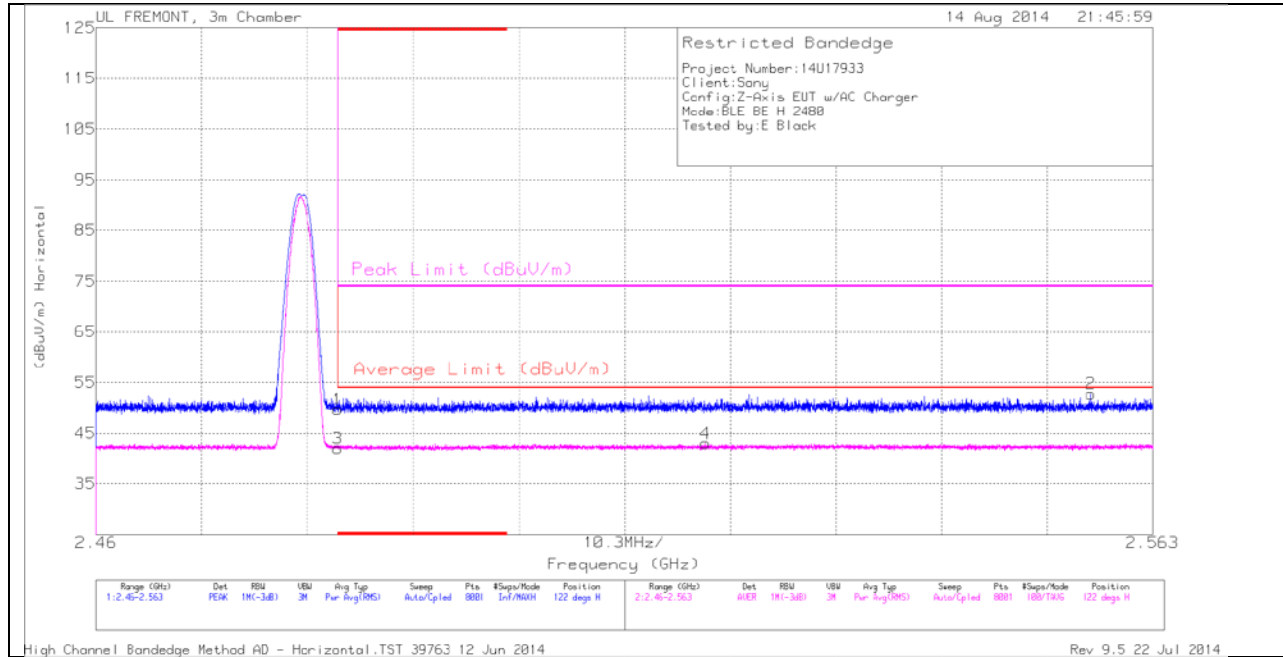

**HORIZONTAL DATA**

Marker	Frequency (GHz)	Meter Reading (dBuV)	Det	AF T119 (dB/m)	Amp/Cb/Fitter/Pad (dB)	DC Corr (dB)	Corrected Reading (dBuV/m)	Average Limit (dBuV/m)	Margin (dB)	Peak Limit (dBuV/m)	PK Margin (dB)	Azimuth (Degs)	Height (cm)	Polarity
1	* 2.484	40.17	PK	32.3	-22.8	0	49.67	-	-	74	-24.33	122	207	H
3	* 2.484	30.38	RMS	32.3	-22.8	2.1	42	54	-12	-	-	122	207	H
4	2.519	31.22	RMS	32.4	-22.8	2.1	42.94	54	-11.06	-	-	122	207	H
2	2.557	43.03	PK	32.4	-22.7	0	52.73	-	-	74	-21.27	122	207	H

**VERTICAL PEAK AND AVERAGE PLOT**

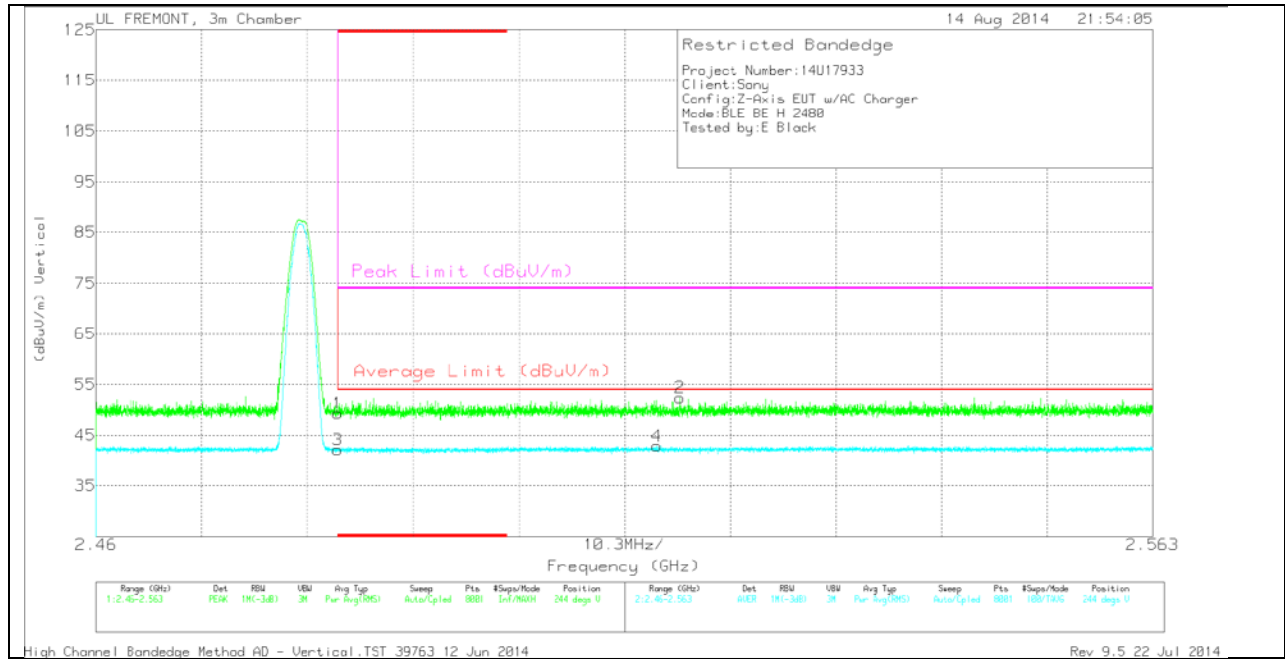

**VERTICAL DATA**

Marker	Frequency (GHz)	Meter Reading (dBuV)	Det	AF T119 (dB/m)	Amp/Cb/Filter/Pad (dB)	DC Corr (dB)	Corrected Reading (dBuV/m)	Average Limit (dBuV/m)	Margin (dB)	Peak Limit (dBuV/m)	PK Margin (dB)	Azimuth (Degs)	Height (cm)	Polarity
1	* 2.484	39.75	PK	32.3	-22.8	0	49.25	-	-	74	-24.75	244	207	V
3	* 2.484	30.46	RMS	32.3	-22.8	2.1	42.08	54	-11.92	-	-	244	207	V
4	2.515	31.24	RMS	32.3	-22.8	2.1	42.86	54	-11.14	-	-	244	207	V
2	2.517	42.82	PK	32.4	-22.8	0	52.42	-	-	74	-21.58	244	207	V

**HARMONICS AND SPURIOUS EMISSIONS**

**LOW CHANNEL HORIZONTAL**

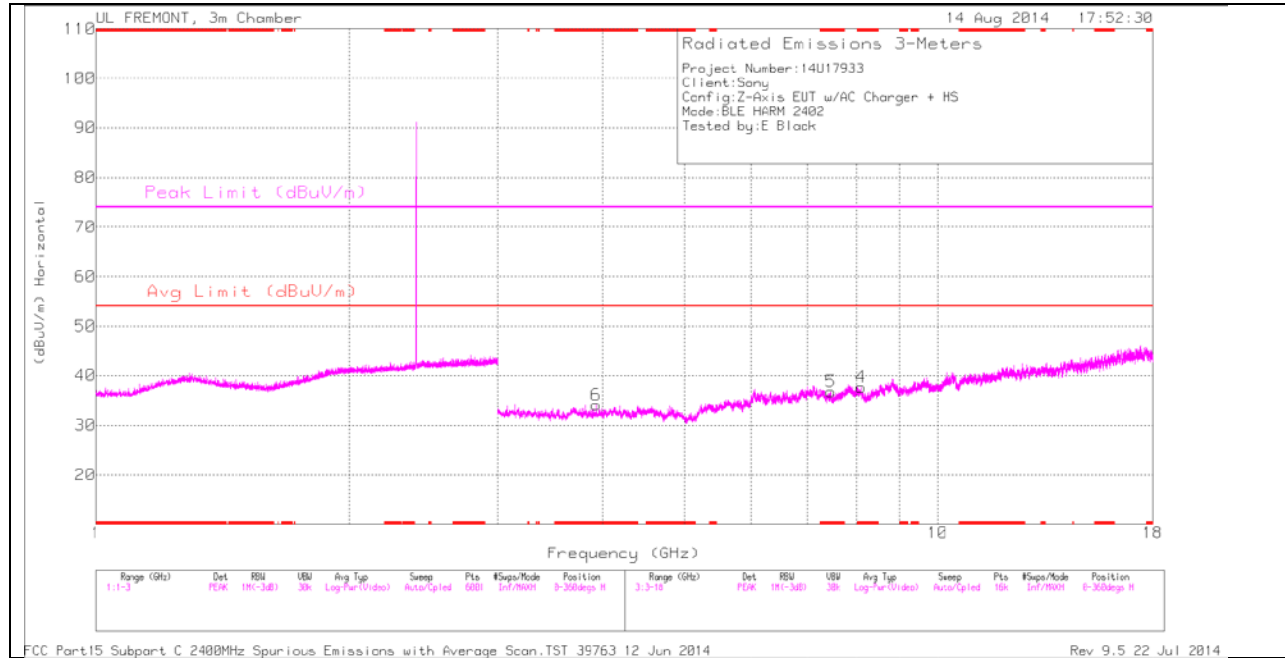

Note: Emission was scanned up to 26GHz; No emissions were detected above the noise floor which was at least 20dB below the specification limit.

### LOW CHANNEL VERTICAL

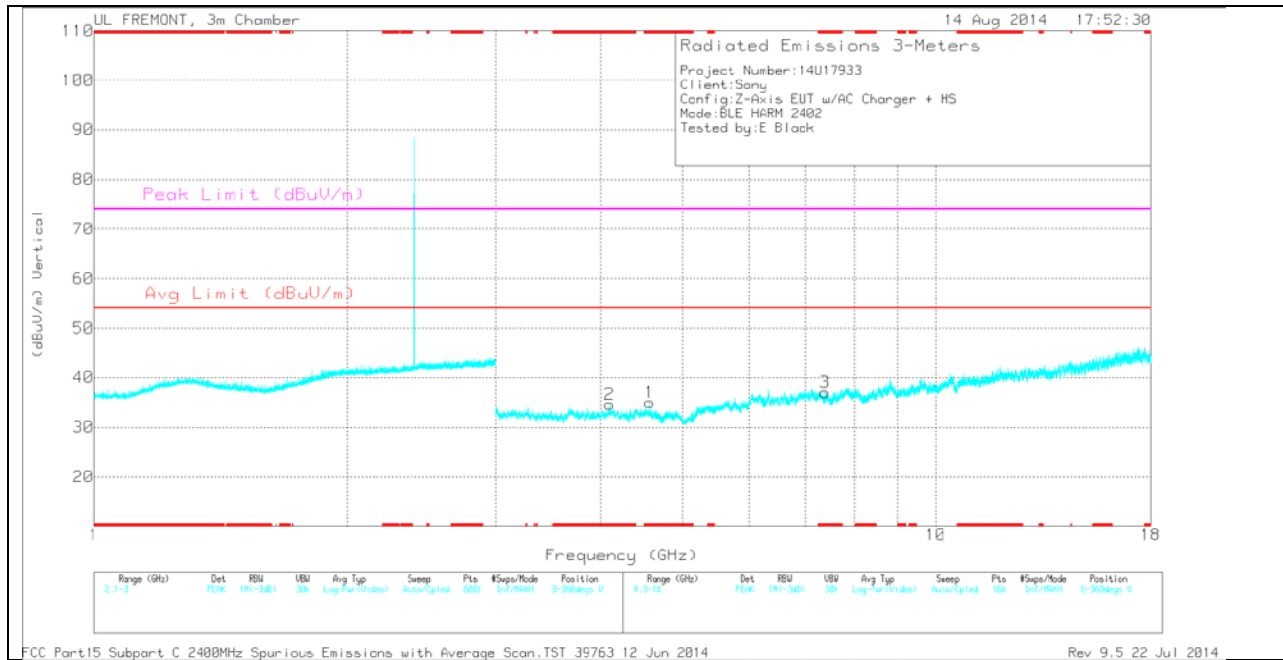

Note: Emission was scanned up to 26GHz; No emissions were detected above the noise floor which was at least 20dB below the specification limit.

**LOW CHANNEL DATA**

*TRACE MARKERS*

Marker	Frequency (GHz)	Meter Reading (dBuV)	Det	AF T119 (dB/m)	Amp/Cbl/Filtr/Pad (dB)	DC Corr (dB)	Corrected Reading (dBuV/m)	Avg Limit (dBuV/m)	Margin (dB)	Peak Limit (dBuV/m)	PK Margin (dB)	Azimuth (Degs)	Height (cm)	Polarity
6	* 3.929	32	PK	33.3	-31.2	0	34.1	-	-	74	-39.9	0-360	100	H
2	* 4.093	32.65	PK	33.5	-31.5	0	34.65	-	-	74	-39.35	0-360	200	V
1	* 4.569	31.86	PK	34	-30.9	0	34.96	-	-	74	-39.04	0-360	100	V
3	* 7.385	29.7	PK	35.7	-28.3	0	37.1	-	-	74	-36.9	0-360	100	V
5	* 7.458	30.21	PK	35.7	-29.1	0	36.81	-	-	74	-37.19	0-360	200	H
4	* 8.099	29.53	PK	35.7	-27.5	0	37.73	-	-	74	-36.27	0-360	200	H

PK - Peak detector

*RADIATED EMISSIONS*

Frequency (GHz)	Meter Reading (dBuV)	Det	AF T119 (dB/m)	Amp/Cbl/Filtr/Pad (dB)	DC Corr (dB)	Corrected Reading (dBuV/m)	Avg Limit (dBuV/m)	Margin (dB)	Peak Limit (dBuV/m)	PK Margin (dB)	Azimuth (Degs)	Height (cm)	Polarity
* 4.571	39.83	PK2	34	-30.9	0	42.93	-	-	74	-31.07	294	272	V
* 4.569	27.77	MAv1	34	-30.9	2.1	32.98	54	-21.02	-	-	294	272	V

### MID CHANNEL HORIZONTAL

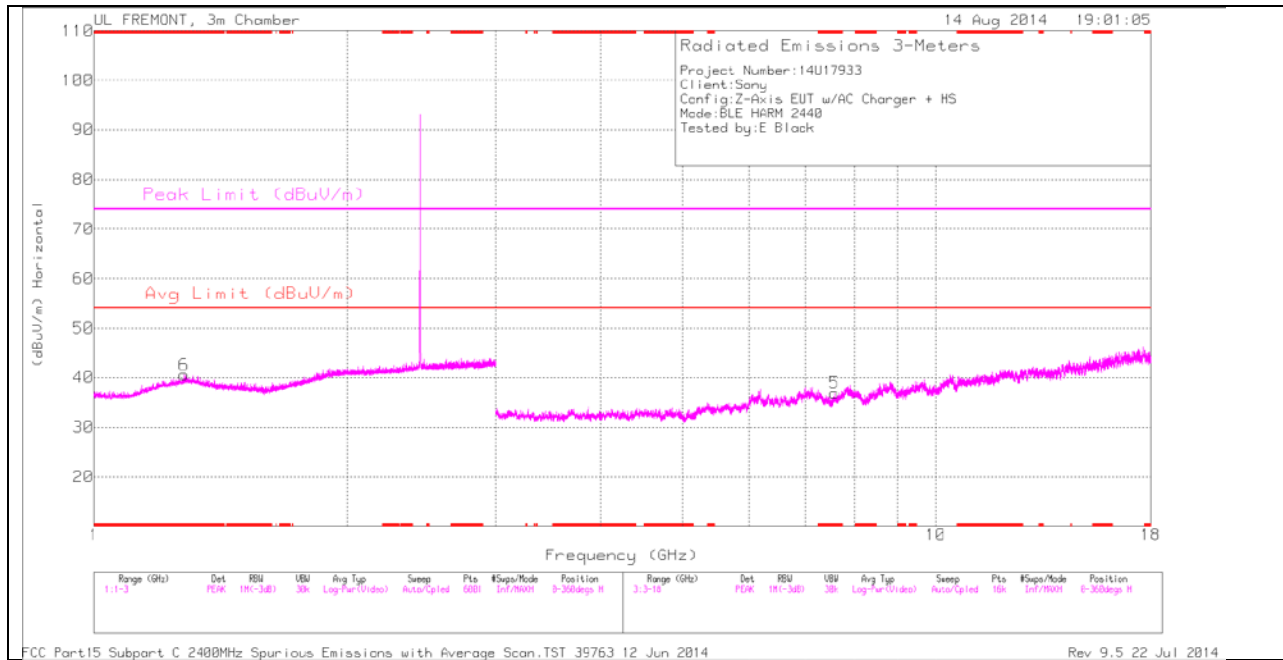

Note: Emission was scanned up to 26GHz; No emissions were detected above the noise floor which was at least 20dB below the specification limit.

### MID CHANNEL VERTICAL

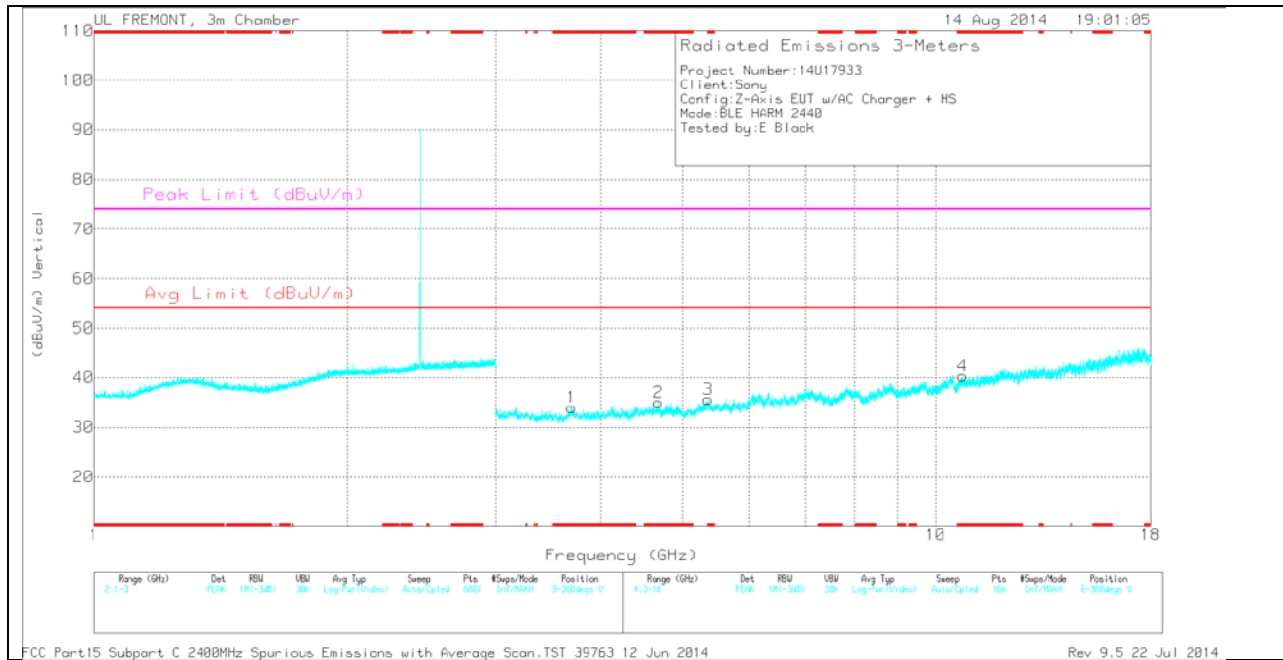

Note: Emission was scanned up to 26GHz; No emissions were detected above the noise floor which was at least 20dB below the specification limit.

**MID CHANNEL DATA**

*TRACE MARKERS*

Marker	Frequency (GHz)	Meter Reading (dBuV)	Det	AF T119 (dB/m)	Amp/Cbl/Filtr/Pad (dB)	DC Corr (dB)	Corrected Reading (dBuV/m)	Avg Limit (dBuV/m)	Margin (dB)	Peak Limit (dBuV/m)	PK Margin (dB)	Azimuth (Degs)	Height (cm)	Polarity
6	* 1.279	34.36	PK	30	-23.8	0	40.56	-	-	74	-33.44	0-360	100	H
5	* 7.576	29.45	PK	35.7	-28.2	0	36.95	-	-	74	-37.05	0-360	200	H
1	* 3.693	31.58	PK	33.2	-30.8	0	33.98	-	-	74	-40.02	0-360	200	V
2	* 4.682	31.65	PK	34.1	-30.7	0	35.05	-	-	74	-38.95	0-360	200	V
3	* 5.361	31.08	PK	34.6	-30	0	35.68	-	-	74	-38.32	0-360	200	V
4	* 10.76	27.39	PK	37.9	-24.9	0	40.39	-	-	74	-33.61	0-360	100	V

PK - Peak detector

*RADIATED EMISSIONS*

Frequency (GHz)	Meter Reading (dBuV)	Det	AF T119 (dB/m)	Amp/Cbl/Filtr/Pad (dB)	DC Corr (dB)	Corrected Reading (dBuV/m)	Avg Limit (dBuV/m)	Margin (dB)	Peak Limit (dBuV/m)	PK Margin (dB)	Azimuth (Degs)	Height (cm)	Polarity
* 10.759	36.37	PK2	37.9	-24.9	0	49.37	-	-	74	-24.63	138	395	V
* 10.761	24.5	MAv1	37.9	-24.9	2.1	39.61	54	-14.39	-	-	138	395	V



### HIGH CHANNEL HORIZONTAL

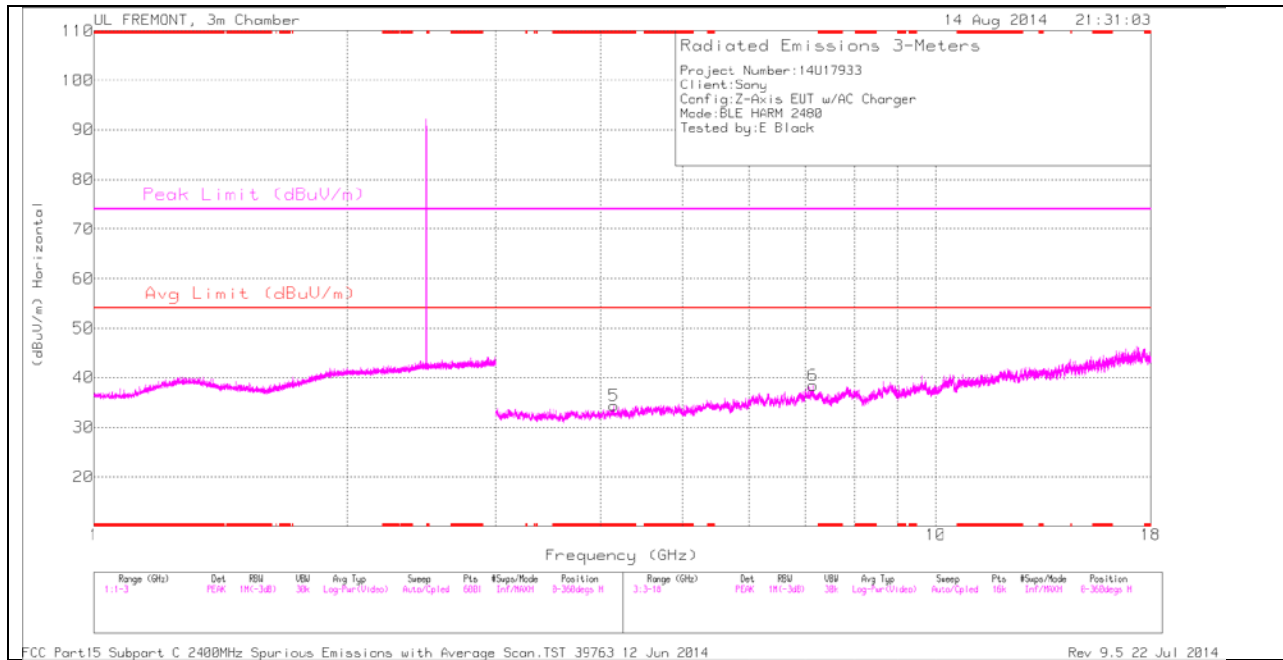

Note: Emission was scanned up to 26GHz; No emissions were detected above the noise floor which was at least 20dB below the specification limit.

### HIGH CHANNEL VERTICAL

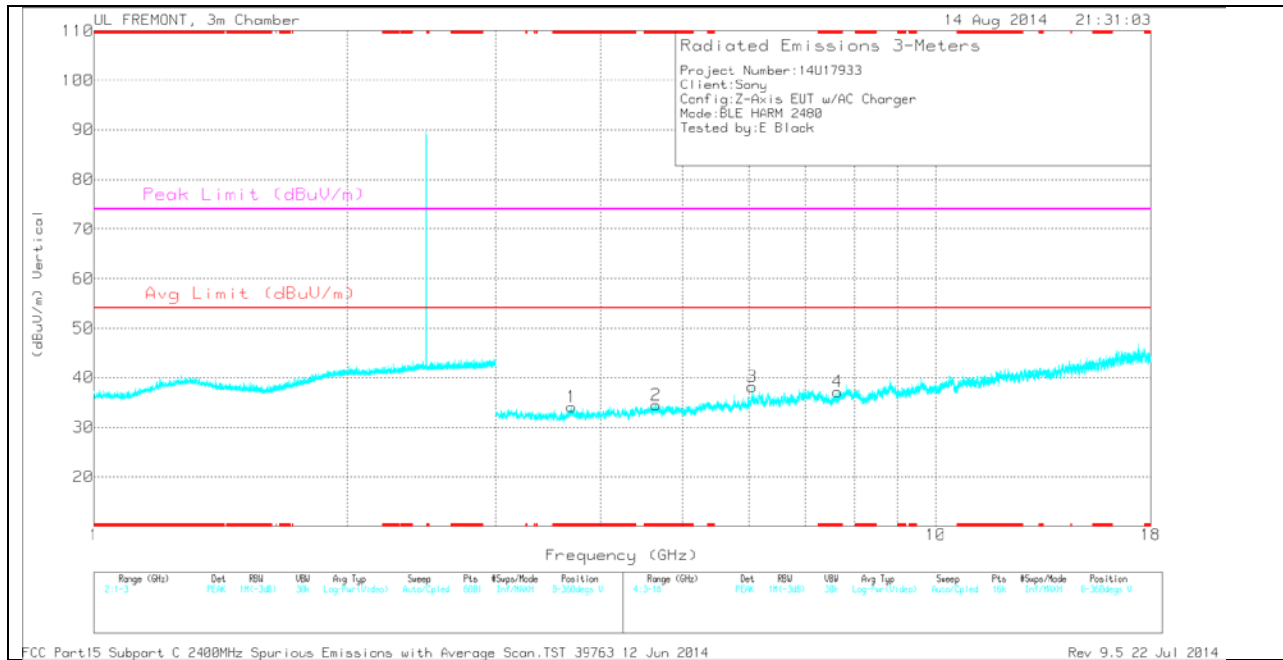

Note: Emission was scanned up to 26GHz; No emissions were detected above the noise floor which was at least 20dB below the specification limit.

**HIGH CHANNEL DATA**

*TRACE MARKERS*

Marker	Frequency (GHz)	Meter Reading (dBuV)	Det	AF T119 (dB/m)	Amp/Cbl/Ftr /Pad (dB)	DC Corr (dB)	Corrected Reading (dBuV/m)	Avg Limit (dBuV/m)	Margin (dB)	Peak Limit (dBuV/m)	PK Margin (dB)	Azimuth (Degs)	Height (cm)	Polarity
5	* 4.144	31.93	PK	33.5	-31	0	34.43	-	-	74	-39.57	0-360	200	H
1	* 3.693	31.68	PK	33.2	-30.8	0	34.08	-	-	74	-39.92	0-360	200	V
2	* 4.653	31.27	PK	34.1	-30.9	0	34.47	-	-	74	-39.53	0-360	200	V
4	* 7.643	29.39	PK	35.8	-28	0	37.19	-	-	74	-36.81	0-360	200	V
3	6.049	32.21	PK	35.3	-29.3	0	38.21	-	-	-	-	0-360	200	V
6	7.149	30.93	PK	35.6	-28.1	0	38.43	-	-	-	-	0-360	200	H

PK - Peak detector

*RADIATED EMISSIONS*

Frequency (GHz)	Meter Reading (dBuV)	Det	AF T119 (dB/m)	Amp/Cbl/Ftr /Pad (dB)	DC Corr (dB)	Corrected Reading (dBuV/m)	Avg Limit (dBuV/m)	Margin (dB)	Peak Limit (dBuV/m)	PK Margin (dB)	Azimuth (Degs)	Height (cm)	Polarity
* 3.693	40.26	PK2	33.2	-30.8	0	42.66	-	-	74	-31.34	34	230	V
* 3.693	28.24	MAv1	33.2	-30.8	2.1	32.75	54	-21.25	-	-	34	230	V

### 8.3. WORST-CASE BELOW 1 GHz

#### SPURIOUS EMISSIONS 30 TO 1000 MHz (WORST-CASE CONFIGURATION)

#### HORIZONTAL PLOT

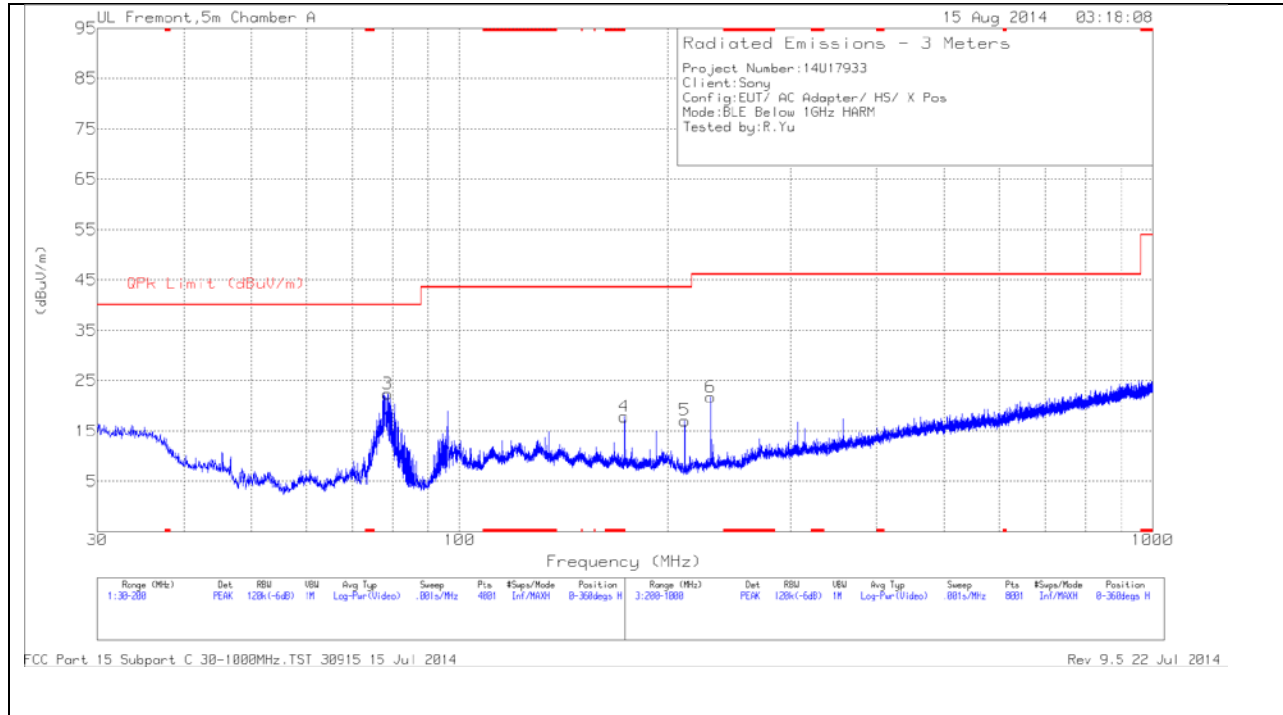

**VERTICAL PLOT**

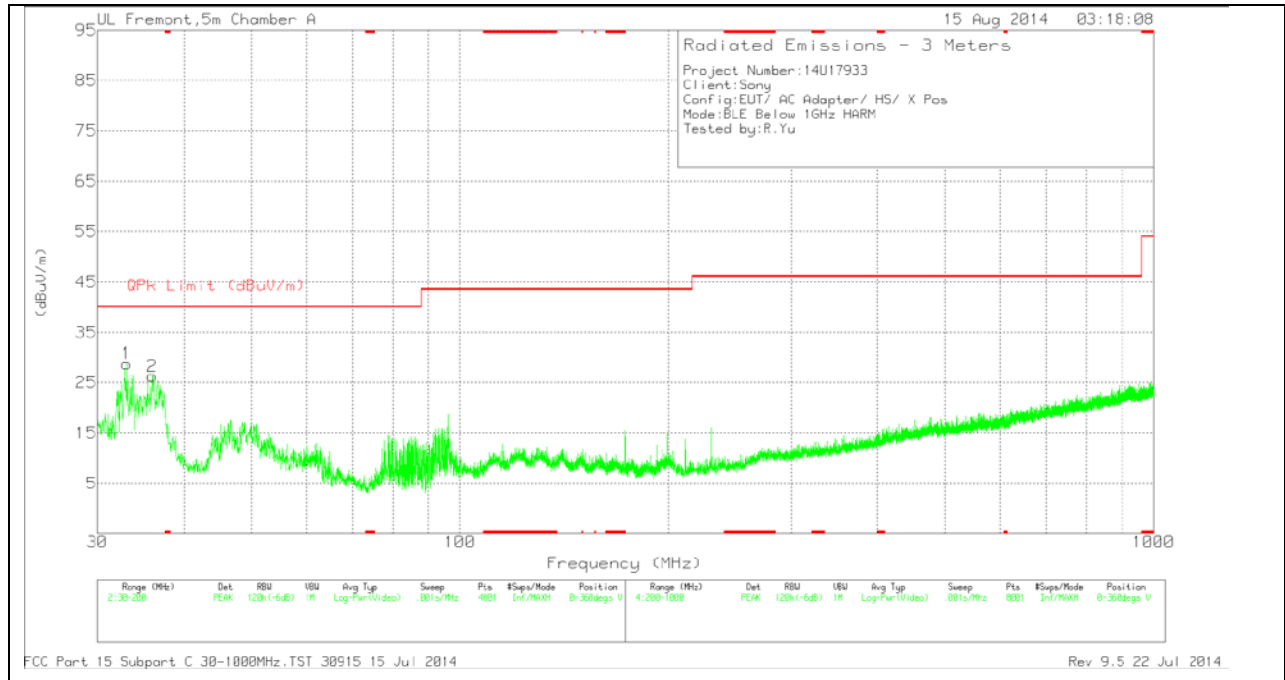

**BELOW 1 GHz TABLE**

Marker	Frequency (MHz)	Meter Reading (dBuV)	Det	AF T130 (dB/m)	Amp/Cbl (dB/m)	Corrected Reading (dBuV/m)	QPk Limit (dBuV/m)	Margin (dB)	Azimuth (Degs)	Height (cm)	Polarity
4	* 172.8	36.17	PK	11.7	-30	17.87	43.52	-25.65	0-360	200	H
1	33.0175	40.39	PK	19.5	-31.1	28.79	40	-11.21	0-360	101	V
2	35.9925	40.07	PK	17.3	-31.1	26.27	40	-13.73	0-360	101	V
3	78.705	45.61	PK	7.7	-30.9	22.41	40	-17.59	0-360	300	H
5	211.2	36.4	PK	10.5	-29.8	17.1	43.52	-26.42	0-360	101	H
6	230.4	40.29	PK	11.1	-29.6	21.79	46.02	-24.23	0-360	101	H

PK - Peak detector

## 9. AC POWER LINE CONDUCTED EMISSIONS

### LIMITS

FCC §15.207 (a)

Frequency of Emission (MHz)	Conducted Limit (dBuV)	
	Quasi-peak	Average
0.15-0.5	66 to 56*	56 to 46*
0.5-5	56	46
5-30	60	50

\*Decreases with the logarithm of the frequency.

### TEST PROCEDURE

ANSI C63.4 - 2009

**RESULTS**

**6 WORST EMISSIONS**

**LINE 1 PLOT**

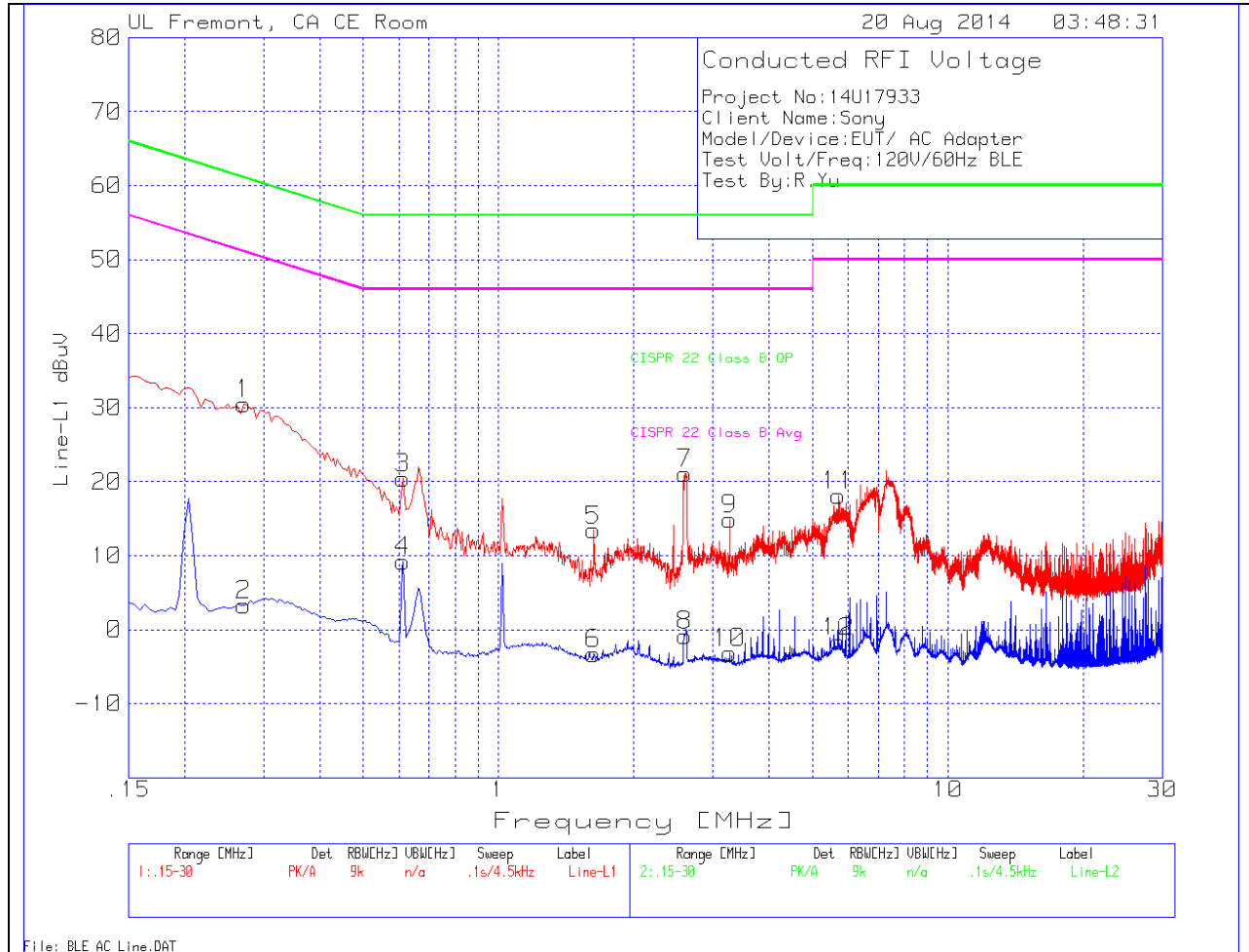

## LINE 1 RESULTS

### Trace Markers

Marker	Frequency (MHz)	Meter Reading (dBuV)	Det	T24 IL L1 (dB)	LC Cables 1&3 (dB)	Corrected Reading dBuV	CISPR 22 Class B QP	Margin to Limit (dB)	CISPR 22 Class B Avg	Margin to Limit (dB)
1	.2715	29.87	PK	.6	0	30.47	61.1	-30.63	-	-
2	.2715	2.69	Av	.6	0	3.29	-	-	51.1	-47.81
3	.6135	20.17	PK	.3	0	20.47	56	-35.53	-	-
4	.6135	8.94	Av	.3	0	9.24	-	-	46	-36.76
5	1.6305	13.11	PK	.2	.1	13.41	56	-42.59	-	-
6	1.6305	-3.54	Av	.2	.1	-3.24	-	-	46	-49.24
7	2.598	20.76	PK	.2	.1	21.06	56	-34.94	-	-
8	2.598	-1.17	Av	.2	.1	-.87	-	-	46	-46.87
9	3.2685	14.64	PK	.2	.1	14.94	56	-41.06	-	-
10	3.2685	-3.45	Av	.2	.1	-3.15	-	-	46	-49.15
11	5.7165	17.78	PK	.2	.1	18.08	60	-41.92	-	-
12	5.7165	-1.97	Av	.2	.1	-1.67	-	-	50	-51.67



**LINE 2 PLOT**

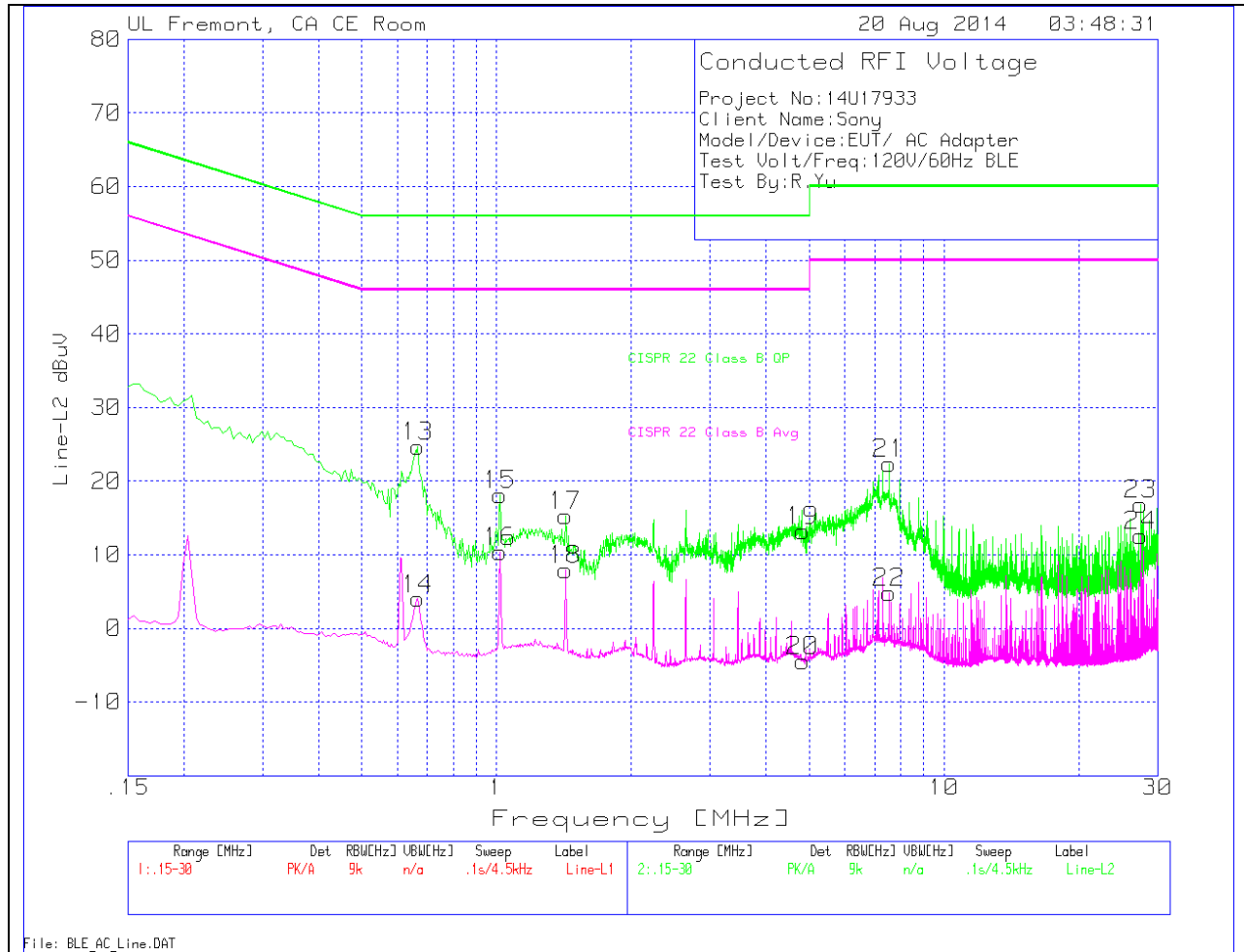

**LINE 2 RESULTS**

**Trace Markers**

Marker	Frequency (MHz)	Meter Reading (dBuV)	Det	T24 IL L2 (dB)	LC Cables 2&3 (dB)	Corrected Reading dBuV	CISPR 22 Class B QP	Margin to Limit (dB)	CISPR 22 Class B Avg	Margin to Limit (dB)
13	.6675	24.35	PK	.3	0	24.65	56	-31.35	-	-
14	.6675	3.7	Av	.3	0	4	-	-	46	-42
15	1.0185	17.86	PK	.3	0	18.16	56	-37.84	-	-
16	1.0185	10.11	Av	.3	0	10.41	-	-	46	-35.59
17	1.428	15.02	PK	.2	.1	15.32	56	-40.68	-	-
18	1.428	7.6	Av	.2	.1	7.9	-	-	46	-38.1
19	4.839	12.94	PK	.2	.1	13.24	56	-42.76	-	-
20	4.839	-4.76	Av	.2	.1	-4.46	-	-	46	-50.46
21	7.5345	22.11	PK	.2	.1	22.41	60	-37.59	-	-
22	7.5345	4.54	Av	.2	.1	4.84	-	-	50	-45.16
23	27.537	16.27	PK	.3	.3	16.87	60	-43.13	-	-
24	27.537	11.93	Av	.3	.3	12.53	-	-	50	-37.47