

Annex E Proximity sensor data

Appendix to Test Report No.: 1-6965/13-14-02



Testing Laboratory

CETECOM ICT Services GmbH

Untertürkheimer Straße 6 – 10

66117 Saarbrücken/Germany

Phone: + 49 681 5 98 - 0

Fax: + 49 681 5 98 - 9075

Internet: <http://www.cetecom.com>

e-mail: ict@cetecom.com

Accredited Test Laboratory:

The testing laboratory (area of testing) is accredited according to DIN EN ISO/IEC 17025 (2005) by the Deutsche Akkreditierungsstelle GmbH (DAkkS)

The accreditation is valid for the scope of testing procedures as stated in the accreditation certificate with the registration number: D-PL-12076-01-01

1 Proximity sensor

The DUT is equipped with two proximity sensors to reduce the output power if a person is close to the main antenna. The position of the sensors and antenna are as shown in the graphic.

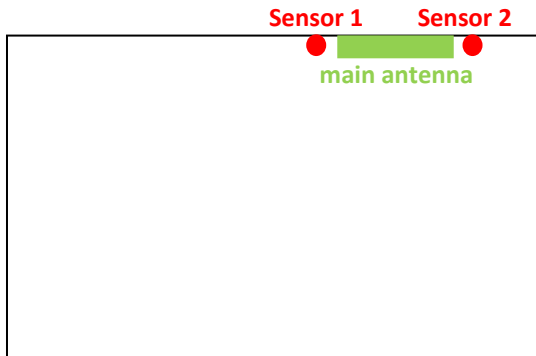

According to KDB 616217 D04 SAR for laptop and tablets v01r01 the functionality of the sensors has to be approved for different aspects:

- Triggering distances
- Sensor coverage of the relevant area
- Sensor functionality in tilted positions
- Safety mechanisms in case of sensor Malfunction
- Material dependency of the triggering distances

1.1 Power reduction:

When one of the sensors is triggered the power will be reduced according to the following table:

Operating mode	Power reduction [dB]
GSM 850	> 3.6
GSM 1900	> 6.2
UMTS FDD II	> 11.0
UMTS FDD V	> 4.2
LTE FDD 2	> 7.0
LTE FDD 4	> 7.2
LTE FDD 7	> 4.6
LTE FDD 13	> 1.4
C2K BC0	> 4.3
C2K BC1	> 10.3

More detailed information can be seen in **CONDUCTED MEASUREMENTS RESULTS**.

1.2 Resulting test positions for SAR measurements.

The smallest separation distance determined during triggering distance, sensor coverage and tilt angle test is selected for SAR measurements. Final verdict of safety distance:

position	triggering distance	coverage	tilting	resulting measurement distance for SAR
top edge	10	12	10	10 mm
rear	16	17	---	16 mm

1.3 Safety measures in case of sensor malfunctions

The operational description contains information explaining how the device remains compliant in the event of a sensor malfunction.

1.4 Material dependency of triggering distances

The triggering variations and hysteresis effect must be evaluated separately according to the tissue-equivalent medium required for each frequency band, to identify the proper SAR test separation distances. As the sensors in the DUT trigger with different sensitivity for different mediums, it is necessary to perform all measurements in all specific Bands with the corresponding signalization. For GSM and UMTS bands a Rhode & Schwarz CMU200 was used to connect the device. For the LTE bands the communication was made with a Rhode & Schwarz CMW500.

1.5 Triggering distances

The DUT is placed under a flat phantom with a tissue simulating liquid and moved in mm steps upwards and downwards to find the exact triggering distances in each measurement position. The trigger distances of the device form a sort of hysteresis with an upwards triggering and downwards triggering point. The measurement is repeated several times to ensure that the repeatability of the found positions is less than $\pm 1\text{mm}$. The graphics show the measurement of the triggering distances of the positions top edge and rear for the DUT. The testing of the remaining sides and borders is not necessary as the SAR measurements were performed with 0mm distance and no power back-off.

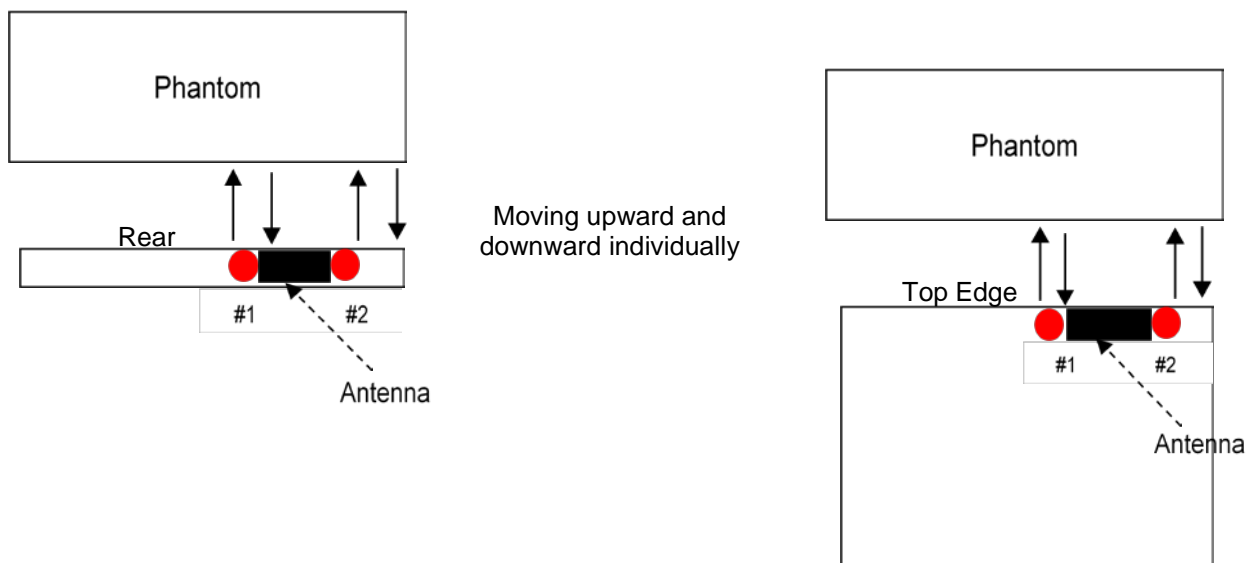

The following measurements were performed with different active sensor settings. The values in the table below show the distances found for the triggering points of the different settings in upwards and downwards direction:

		Rear				Top Edge			
		#1 active		#2 active		#1 active		#2 active	
		up	down	up	down	up	down	up	down
LTE	2	19	22	17	22	15	17	11	17
	4	19	21	18	20	14	17	11	20
	7	21	23	17	18	14	16	13	18
	13	21	23	18	20	16	18	14	17
UMTS	II	19	22	17	22	15	17	11	17
	V	20	22	18	21	17	18	14	16
GSM	1900	19	22	17	22	15	17	11	17
	850	20	22	18	21	17	18	14	16
C2K	BC0	20	22	18	21	17	18	14	16
	BC1	19	22	17	22	15	17	11	17
triggering distance *)		16 mm				11 mm			

*)According to KDB 616217 D04 the smallest distance for movements to and from the phantom, minus 1mm is used as the sensor triggering distance for determining the SAR measurement distance.

1.6 Coverage distances

The back surface or edge of the DUT is positioned at a test separation distance less than or equal to the distance required for back surface or edge triggering, with both the antenna and sensor pad located at least 20 mm laterally outside the edge (boundary) of the phantom, along the direction of maximum antenna and sensor offset. For the back surface, if the direction of maximum offset is not aligned with the tablet coordinates (physical edges) the tablet test position would not be aligned with the phantom coordinates (orientations). Each applicable tablet edge should be positioned perpendicularly to the phantom to determine sensor coverage. For antennas and/or sensors located near the corner of a tablet, both adjacent edges must be considered. The following graphics show the testing positions and movements:

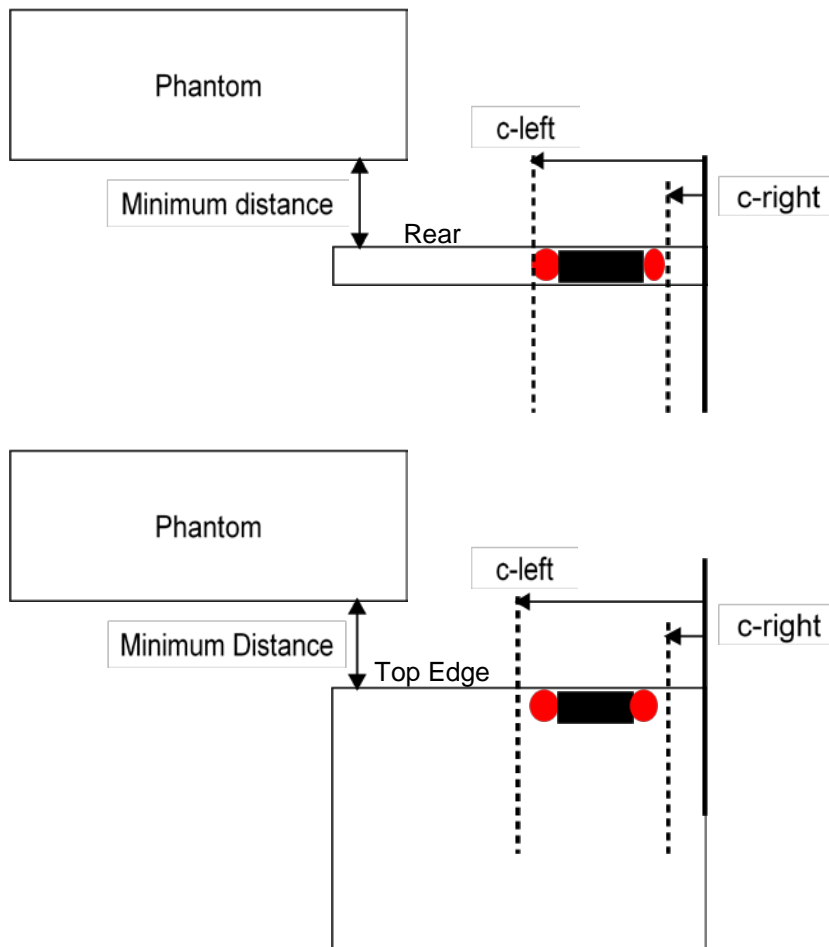

The measurements were performed with different active sensor settings. The values in the table below show the distances in which the sensors were triggered:

		Rear		Minimum Distance (mm)		Edge #1		Minimum Distance (mm)	
		#1	#2	#1	#2	#1	#2	#1	#2
		c-right	c-left			c-right	c-left		
LTE	2	14	106	19	17	15	105	15	12
	4	14	107	19	18	15	107	14	12
	7	16	105	21	17	16	106	14	13
	13	16	105	21	18	15	106	16	14
UMTS	II	14	106	19	17	15	105	15	12
	V	15	107	20	18	16	106	17	14
GSM	1900	14	106	19	17	15	105	15	12
	850	15	107	20	18	16	106	17	14
C2K	BC0	15	107	20	18	16	106	17	14
	BC1	14	106	19	17	15	105	15	12

Detailed results for LTE bandwidths, triggering sensors and movements describing the exact behaviour of the hysteresis are attached in paragraph 5.

1.7 Coverage at tilted positions

The edge of the DUT is positioned at a test separation distance less than or equal to the distance required for triggering, with both the antenna and sensor pad located at least 20 mm laterally. Then it is rotated in 10° increments until +/-45° from the vertical position at 0° tilt angle. If sensor triggering is released and normal maximum output power is restored with the +/-45° range the procedure above is repeated with DUT-to-phantom-separation-distance reduced by 1 mm until the proximity sensor no longer releases triggering and maximum output power remains in reduced mode. The smallest separation distance determined in the steps above – minus 1 mm – is the sensor triggering distance for tablet tilt coverage.

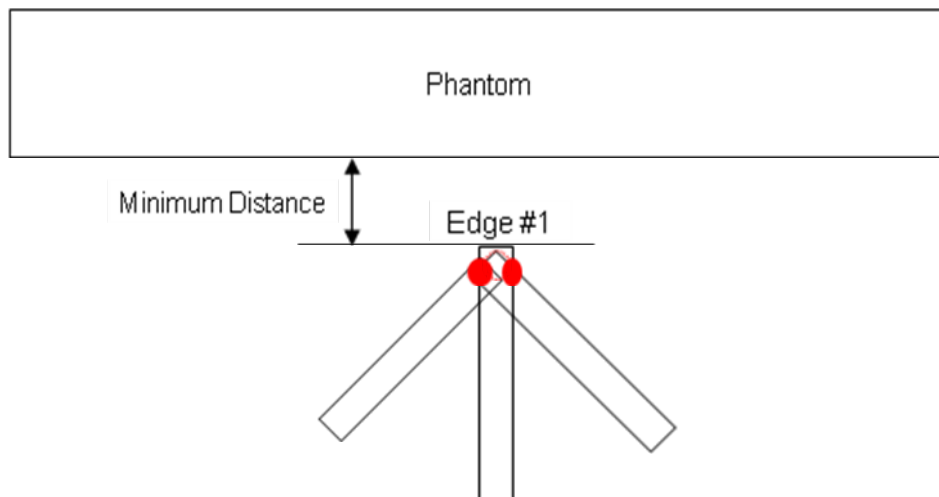

		Minimum Distance (mm)	
		#1	#2
LTE	2	14	10
	4	14	10
	7	13	12
	13	15	13
UMTS	II	14	10
	V	16	13
GSM	1900	14	10
	850	16	13
C2K	BC0	16	13
	BC1	14	10

1.8 Details of LTE behavior and sensor-hysteresis.

LTE FDD 2

Rear position, Sensor 1 active, moving upward

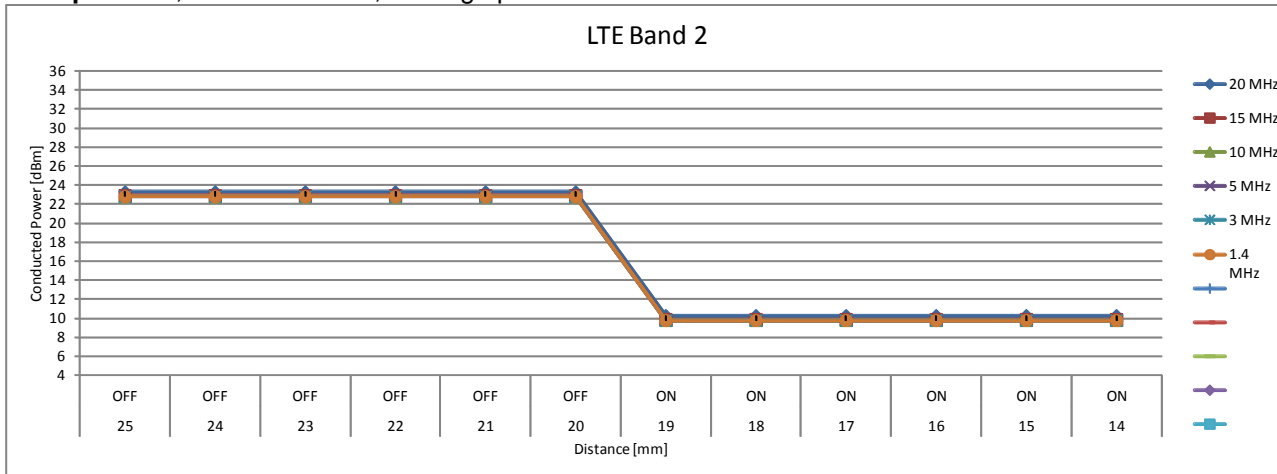

Rear position, Sensor 1 active, moving downward

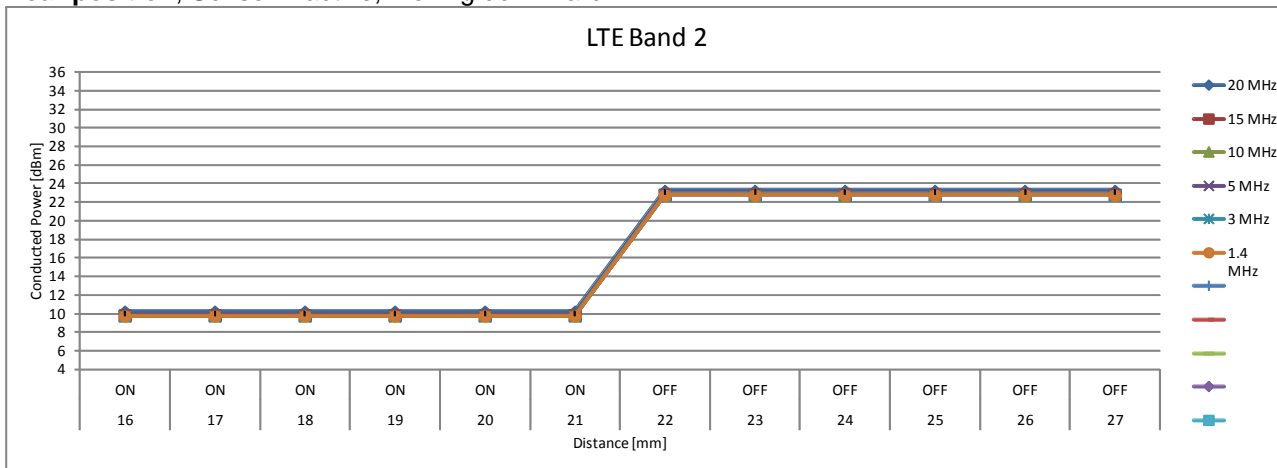

Rear position, Sensor 2 active, moving upward

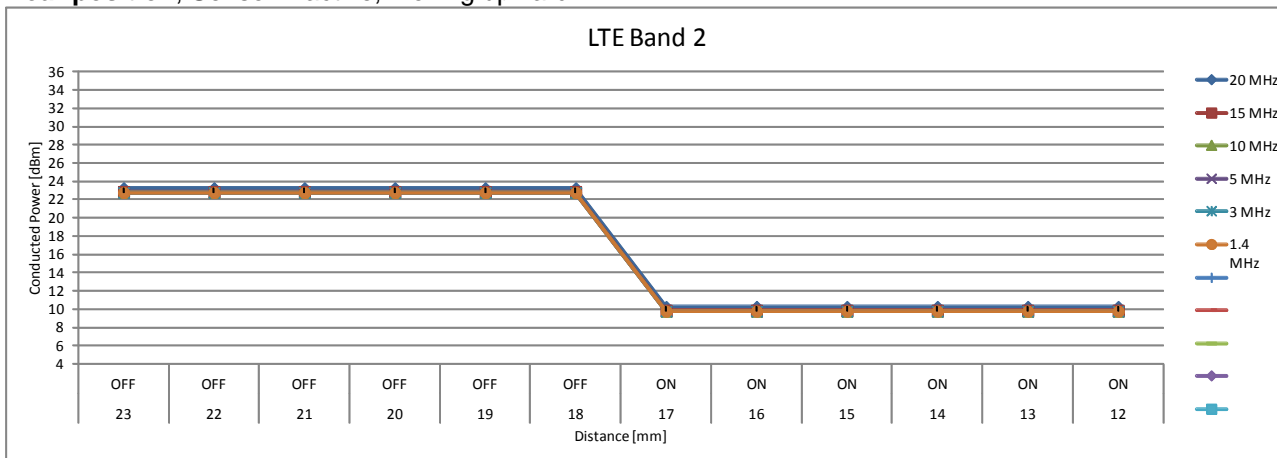

Rear position, Sensor 2 active, moving downward

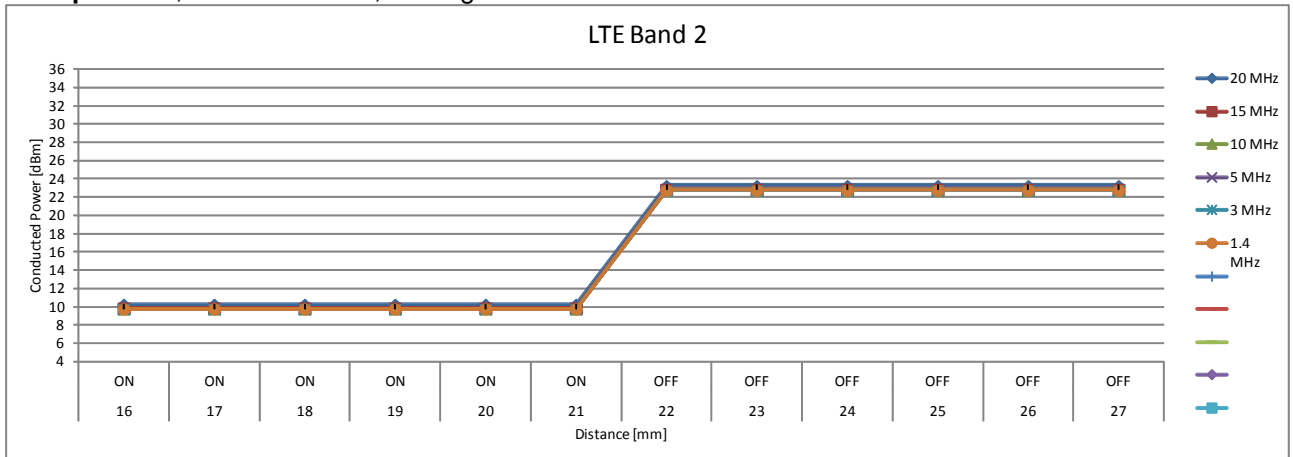

Top Edge position, Sensor 1 active, moving upward

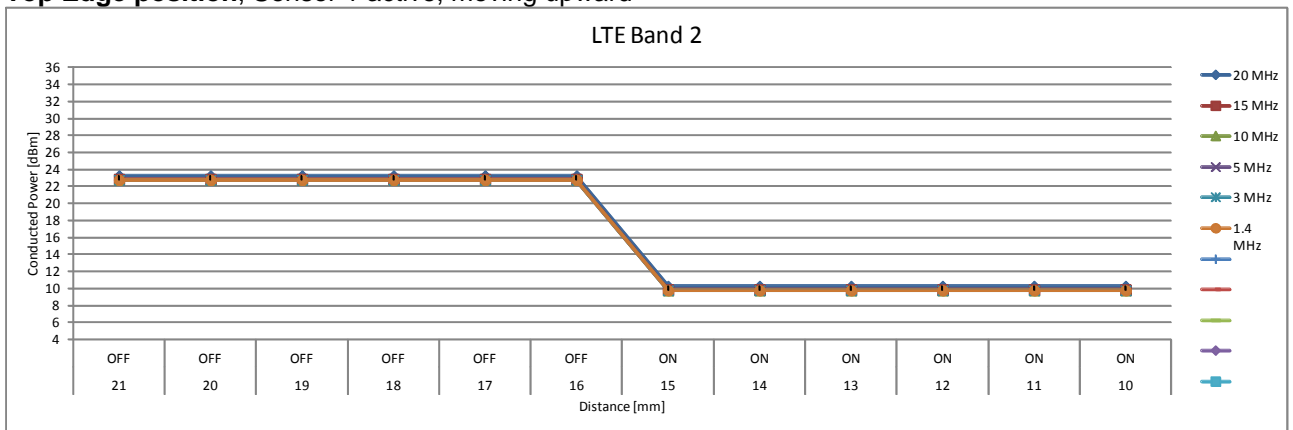

Top Edge position, Sensor 1 active, moving downward

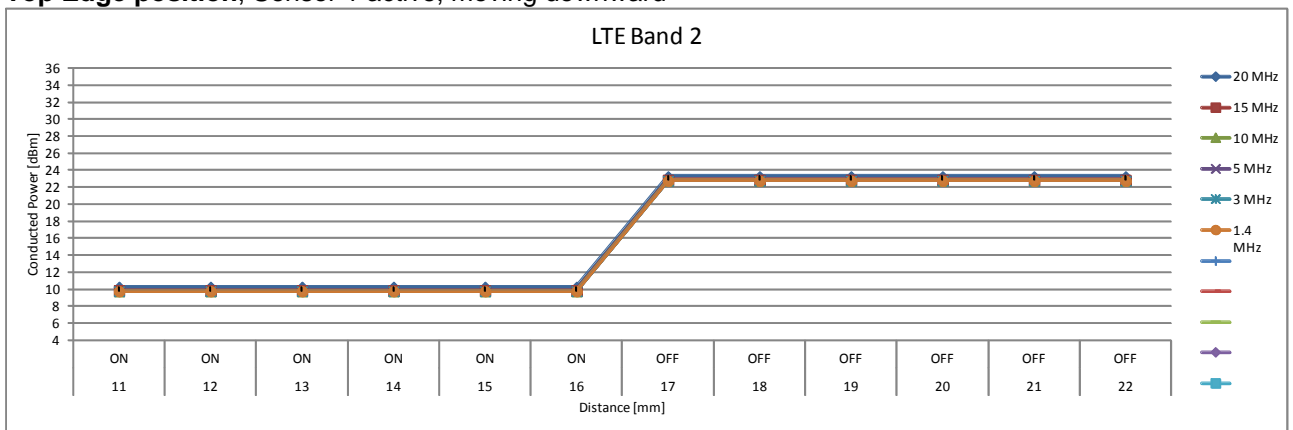

Top Edge position, Sensor 2 active, moving upward

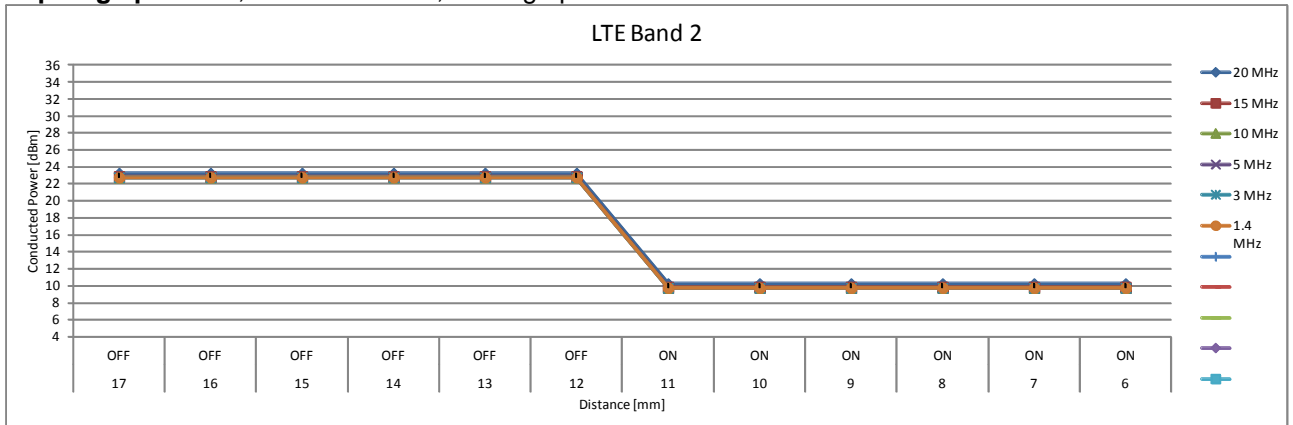

Top Edge position, Sensor 2 active, moving downward

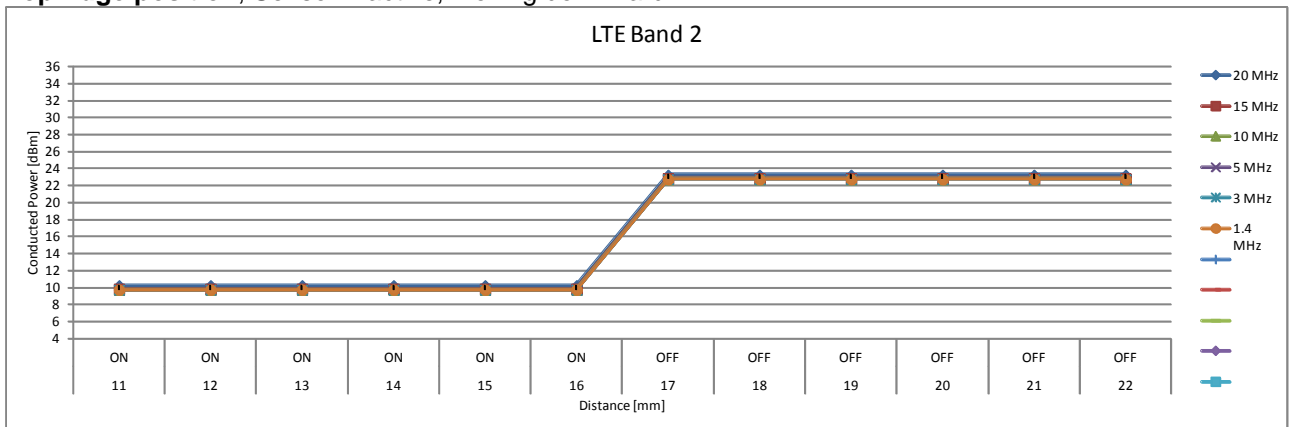

Rear position, Sensor 2 active, moving downward

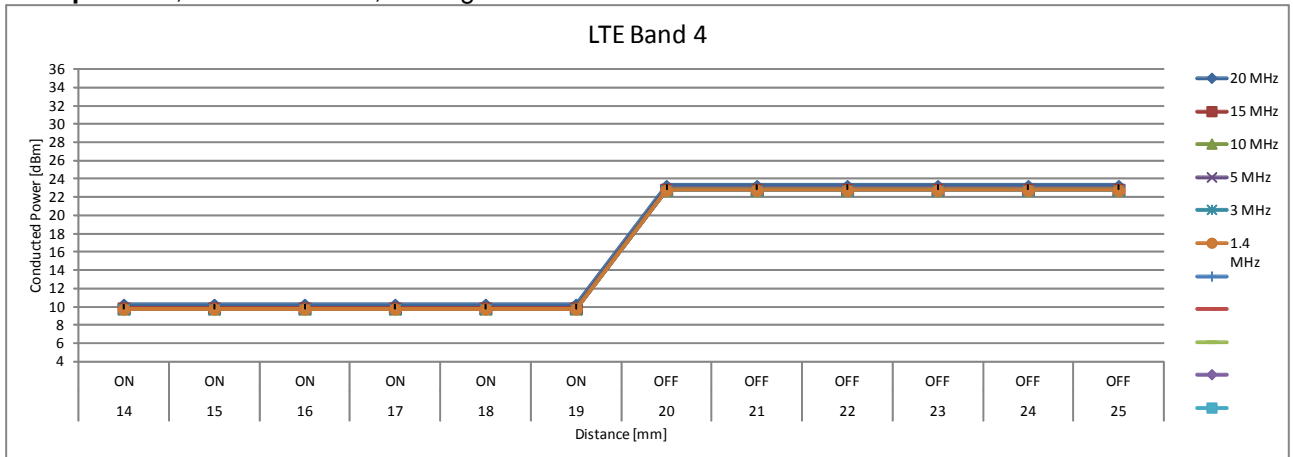

Top Edge position, Sensor 1 active, moving upward

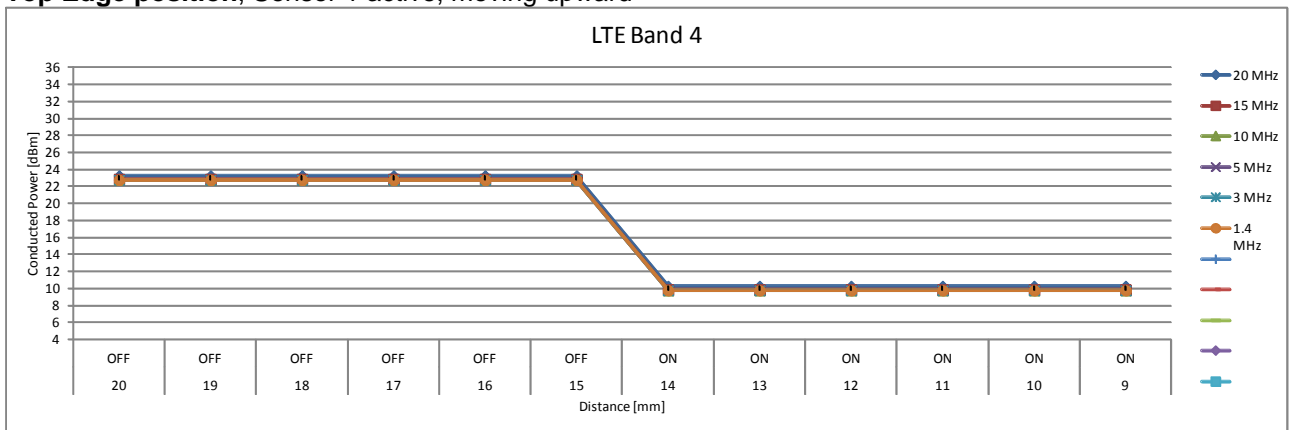

Top Edge position, Sensor 1 active, moving downward

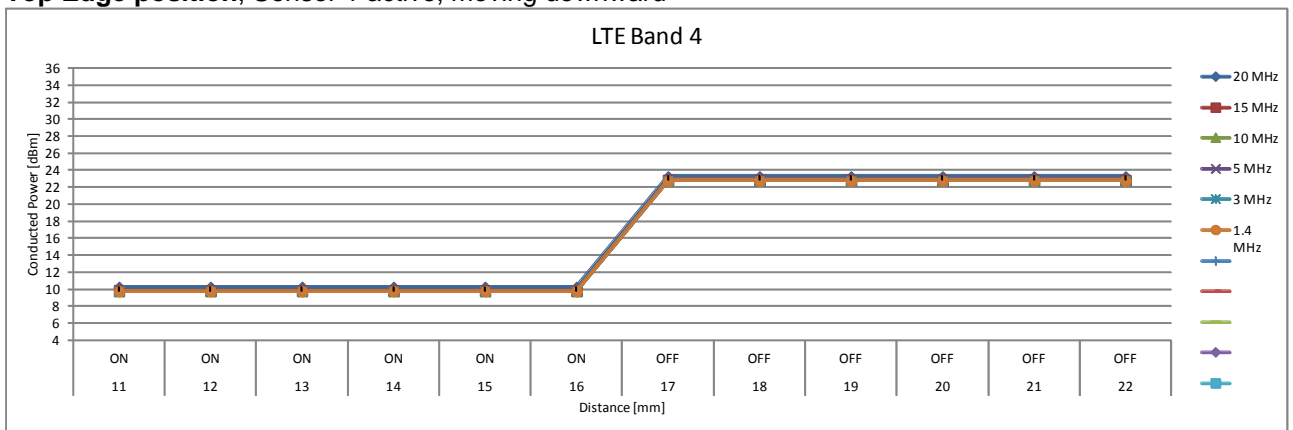

Top Edge position, Sensor 2 active, moving upward

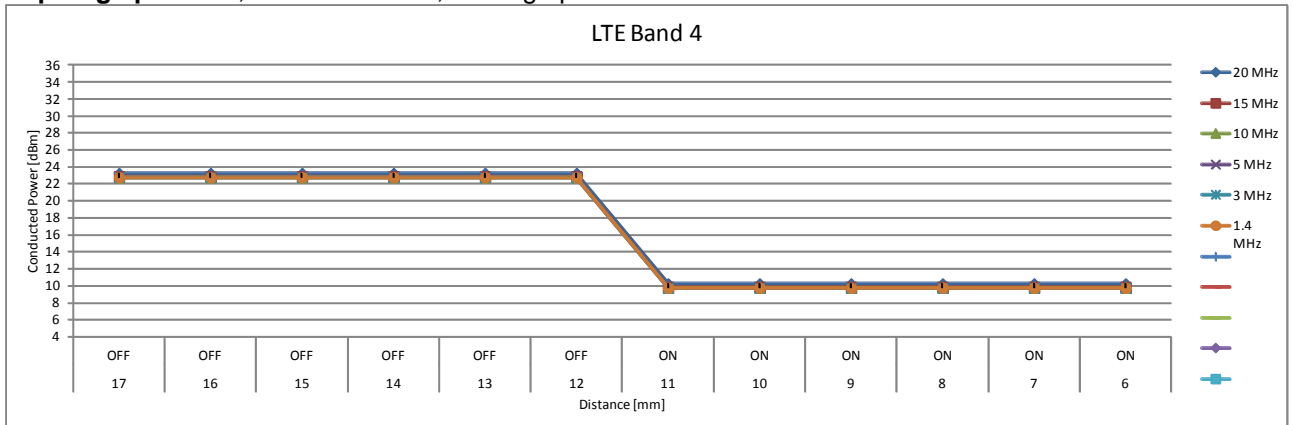

Top Edge position, Sensor 2 active, moving downward

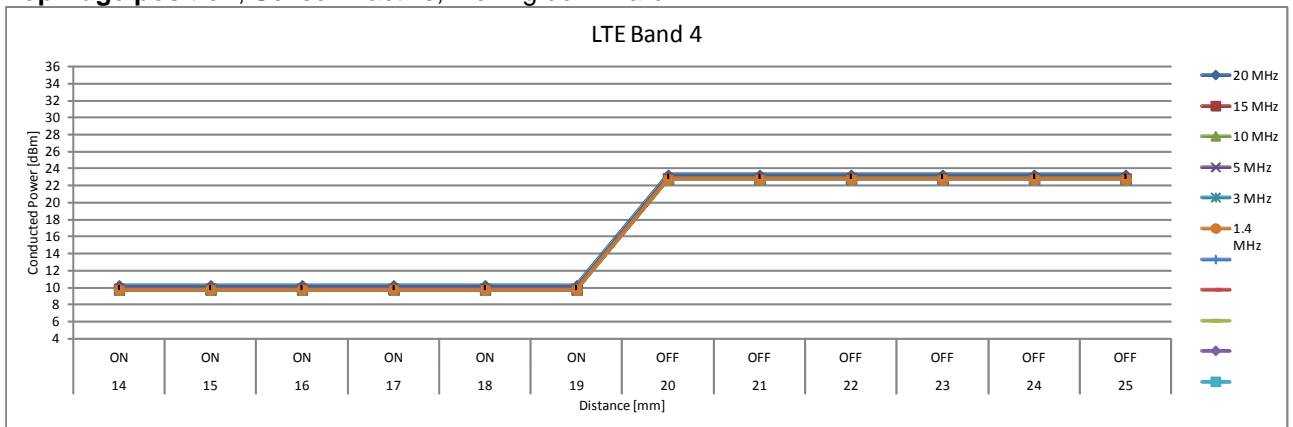



LTE FDD 7

Rear position, Sensor 1 active, moving upward

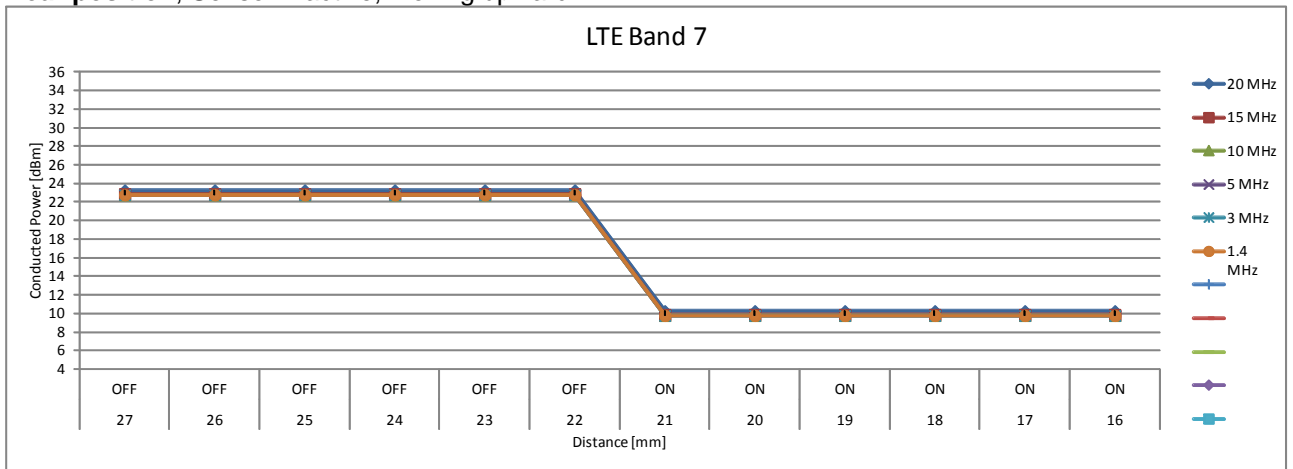

Rear position, Sensor 1 active, moving downward

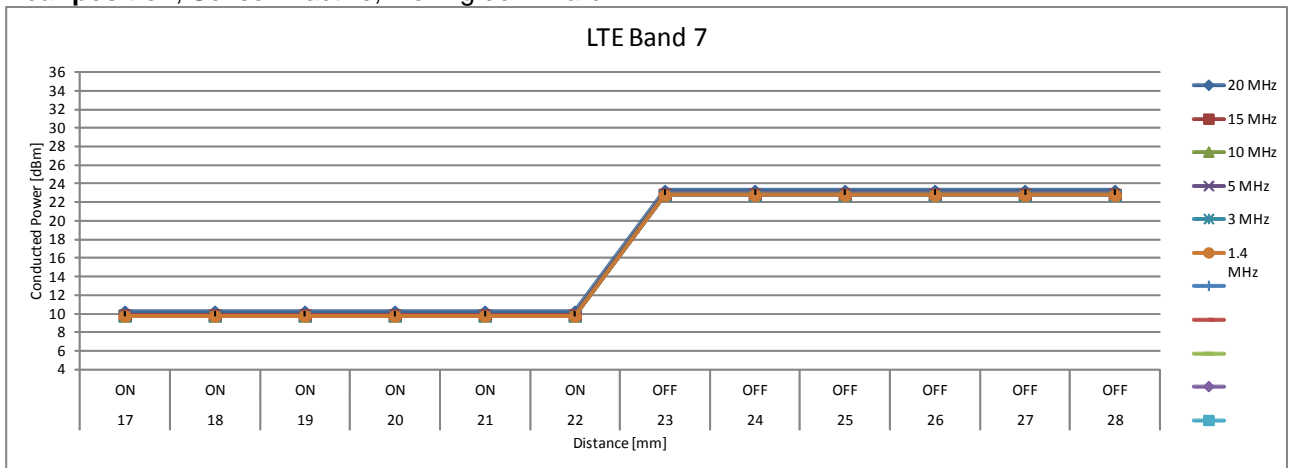

Rear position, Sensor 2 active, moving upward

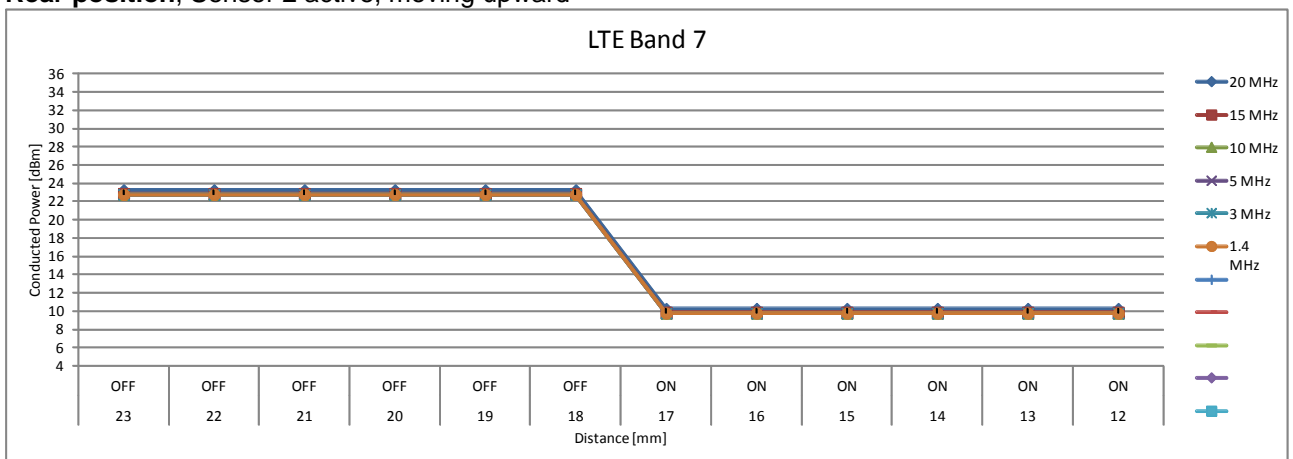

Rear position, Sensor 2 active, moving downward

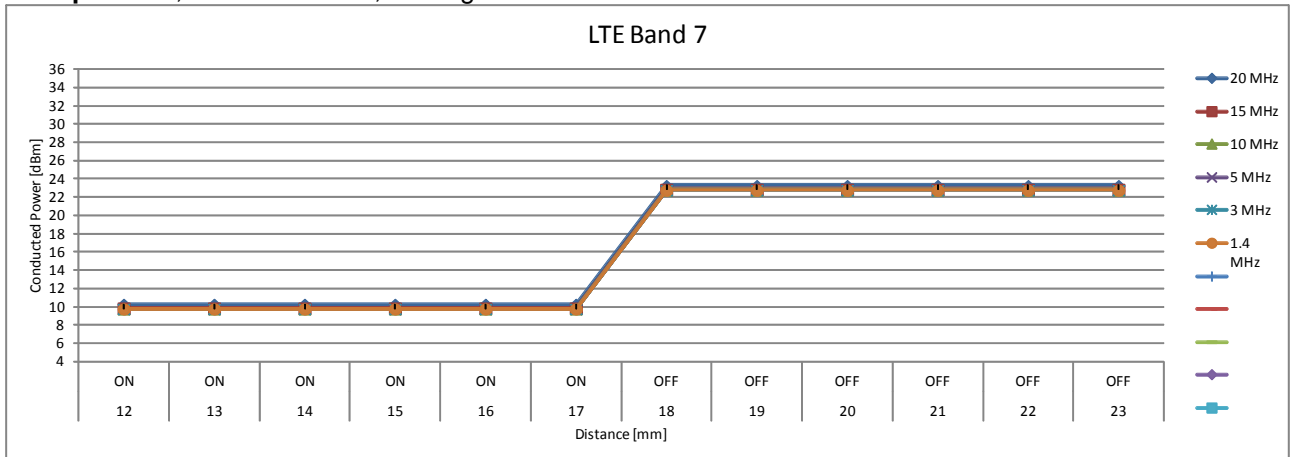

Top Edge position, Sensor 1 active, moving upward

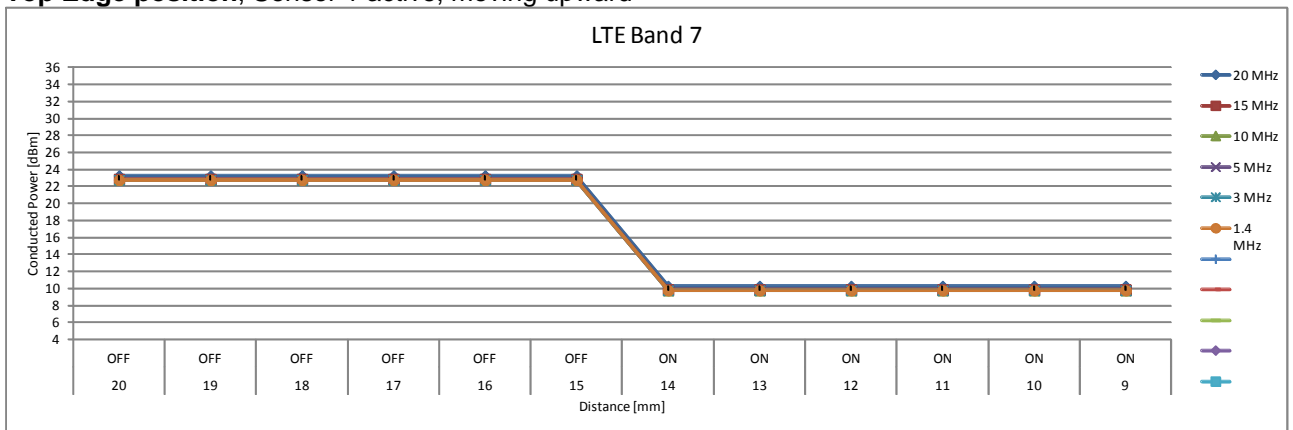

Top Edge position, Sensor 1 active, moving downward

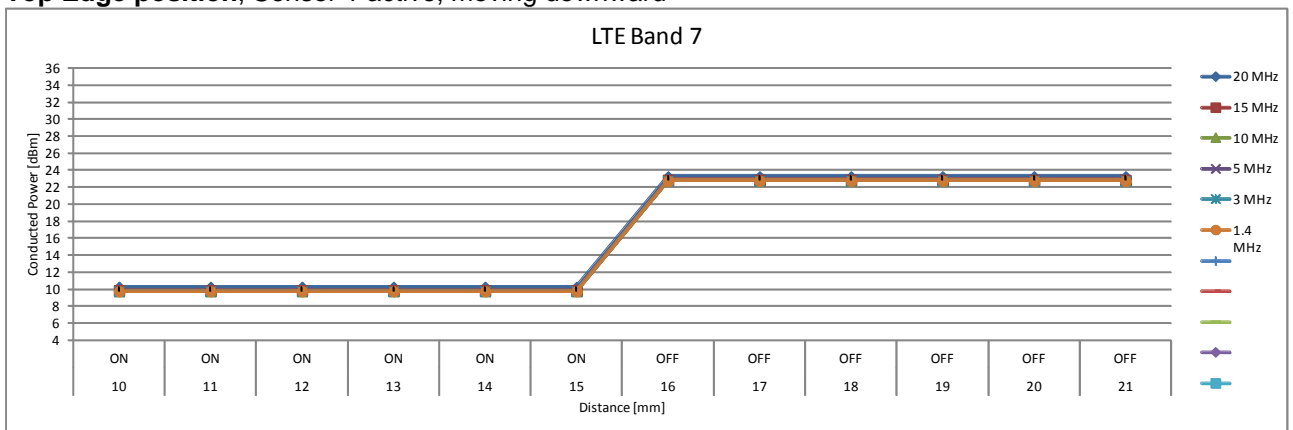

Top Edge position, Sensor 2 active, moving upward

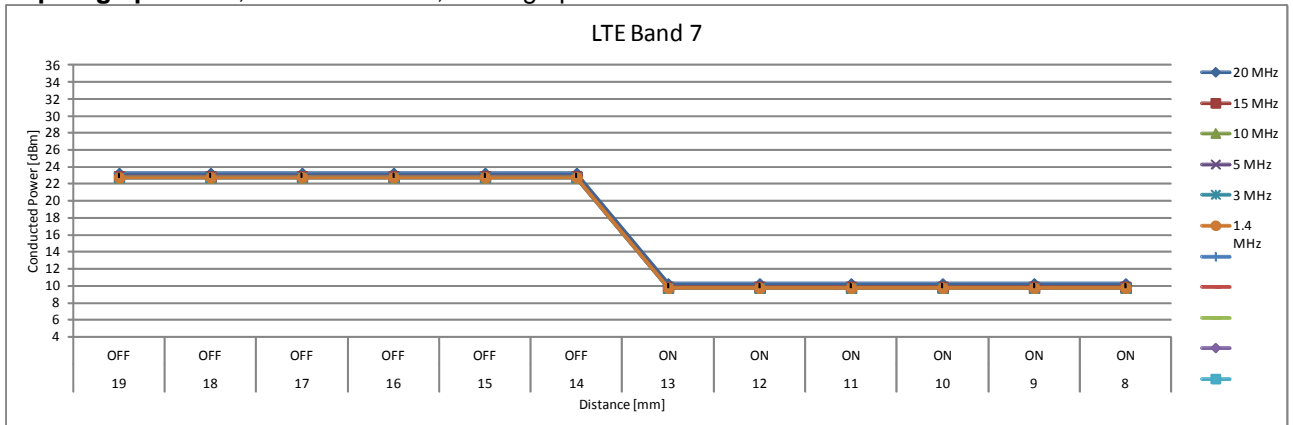

Top Edge position, Sensor 2 active, moving downward

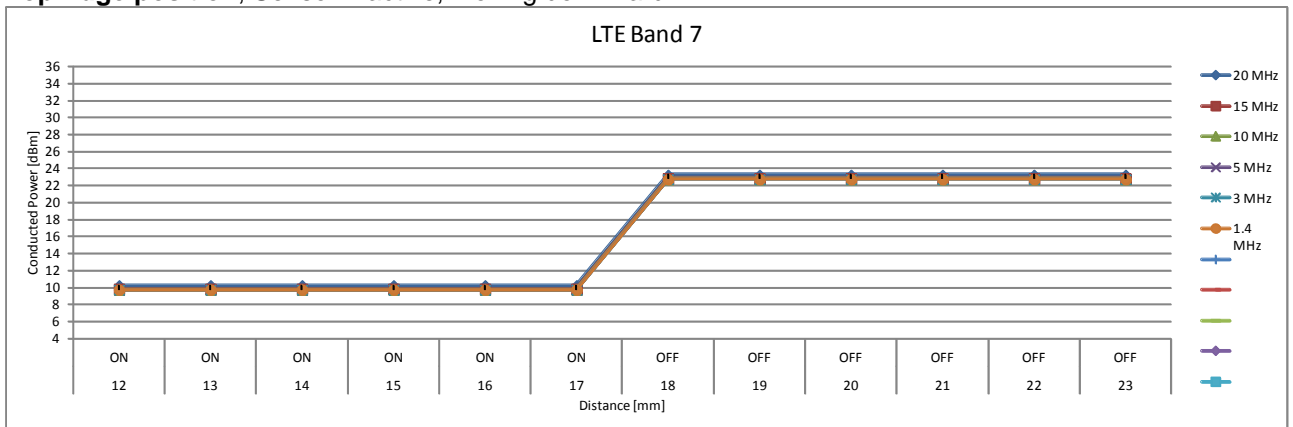

LTE FDD 13

Rear position, Sensor 1 active, moving upward

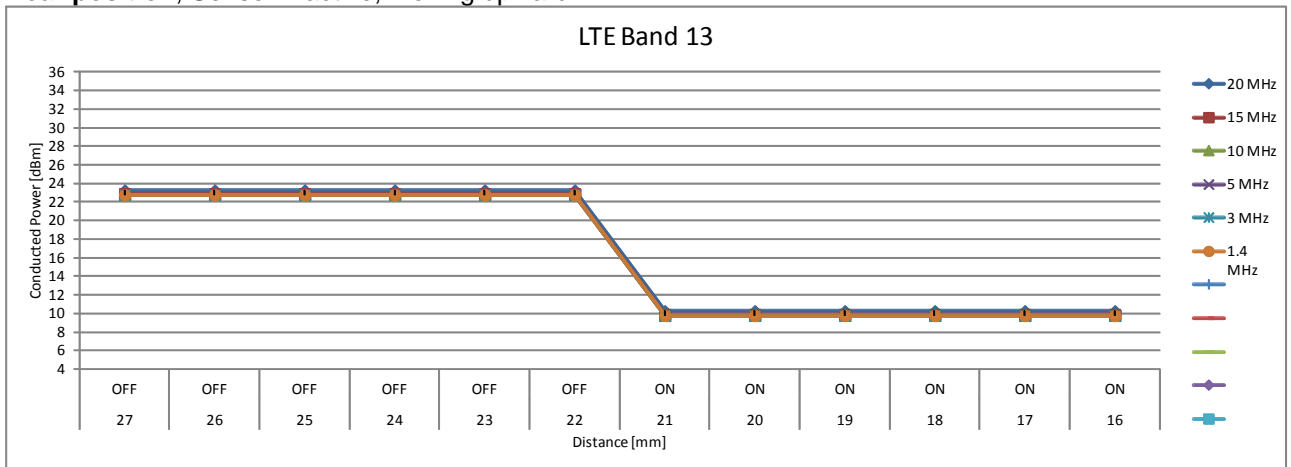

Rear position, Sensor 1 active, moving downward

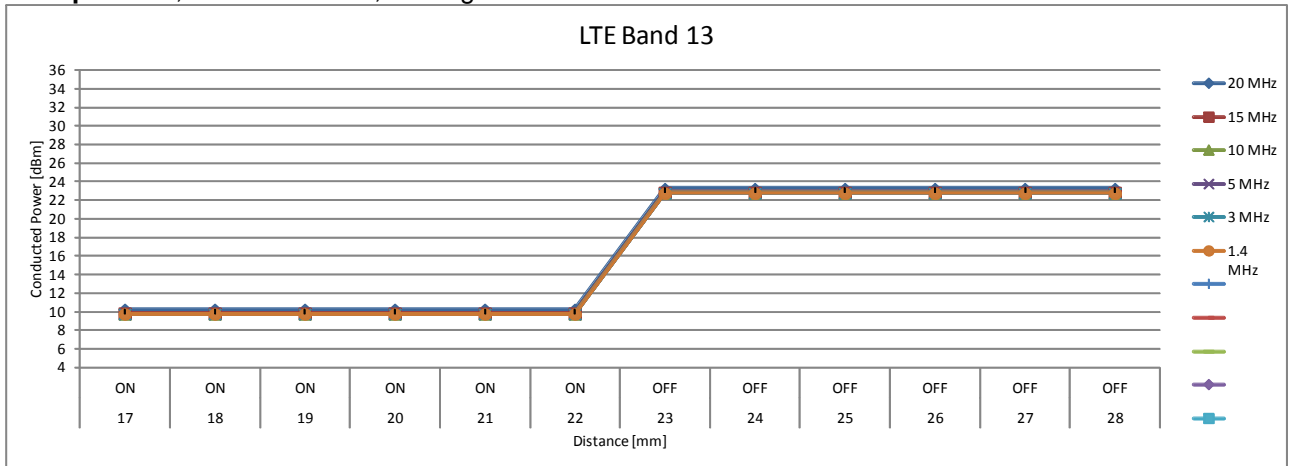

Rear position, Sensor 2 active, moving upward

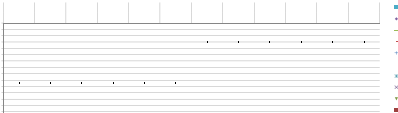
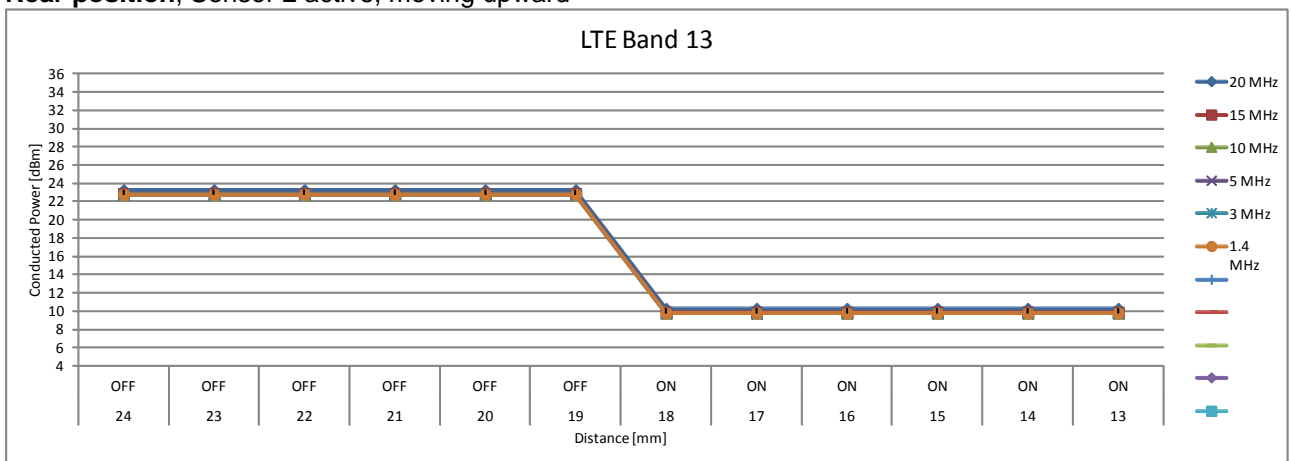

Rear position, Sensor 2 active, moving downward

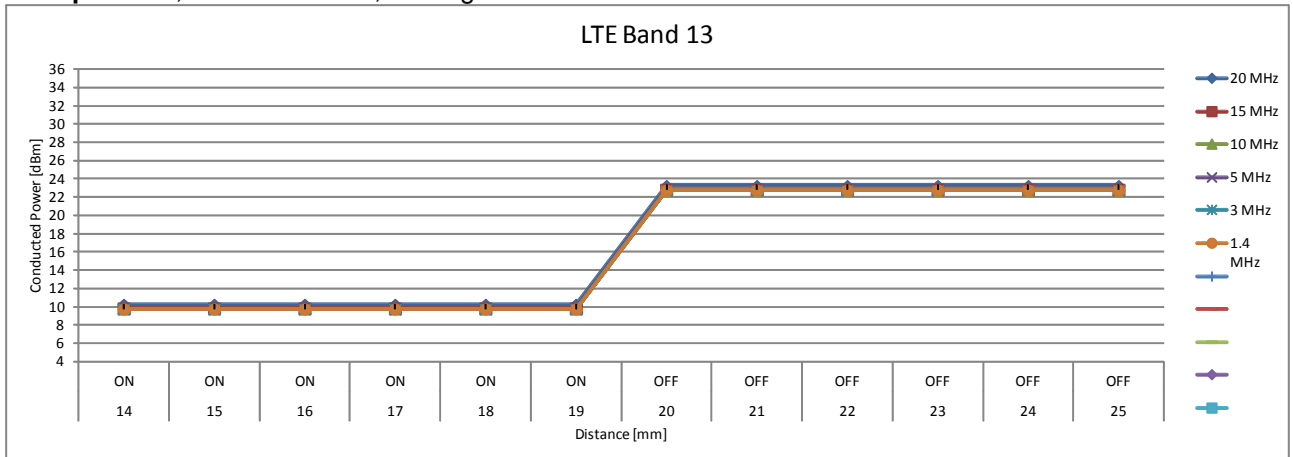

Top Edge position, Sensor 1 active, moving upward

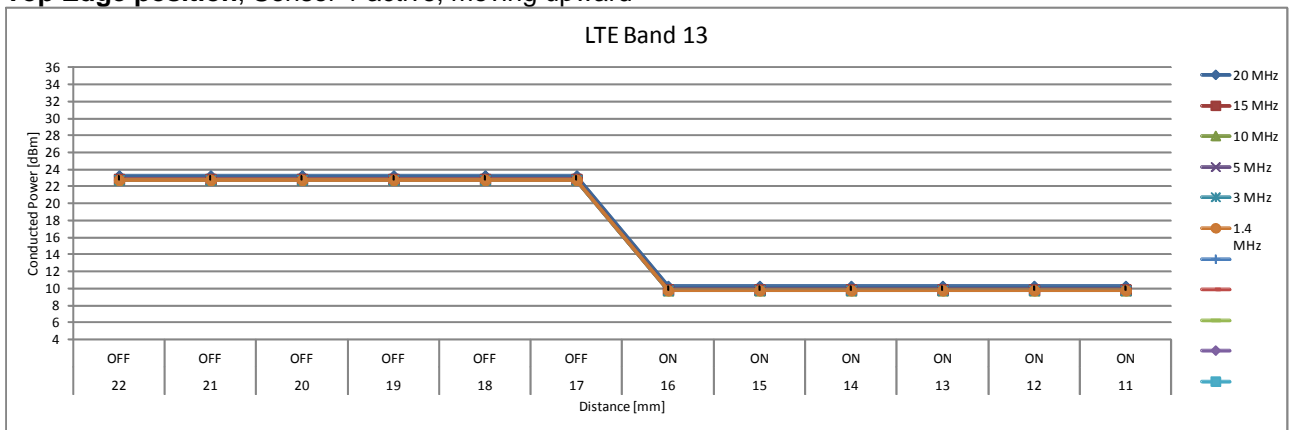

Top Edge position, Sensor 1 active, moving downward

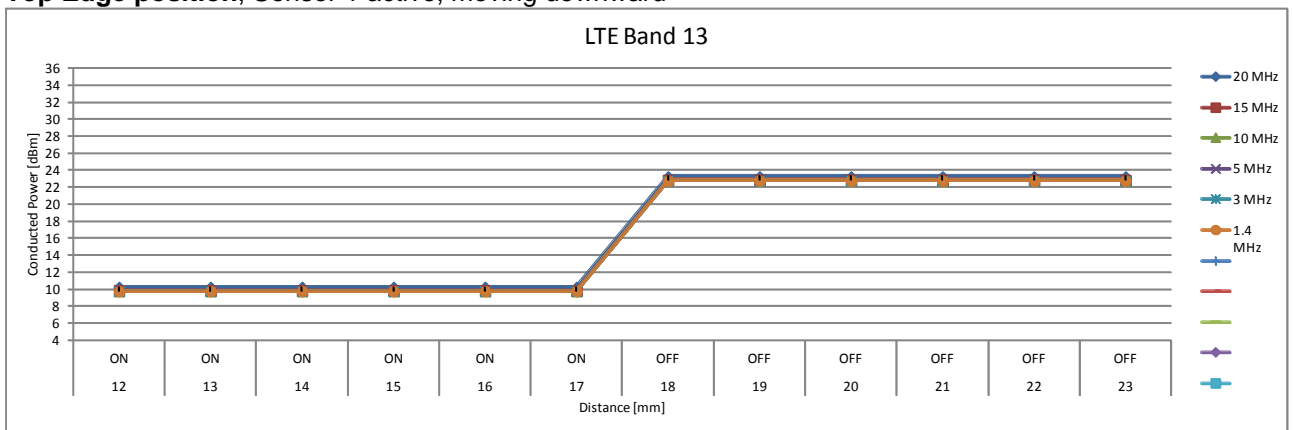

Top Edge position, Sensor 2 active, moving upward

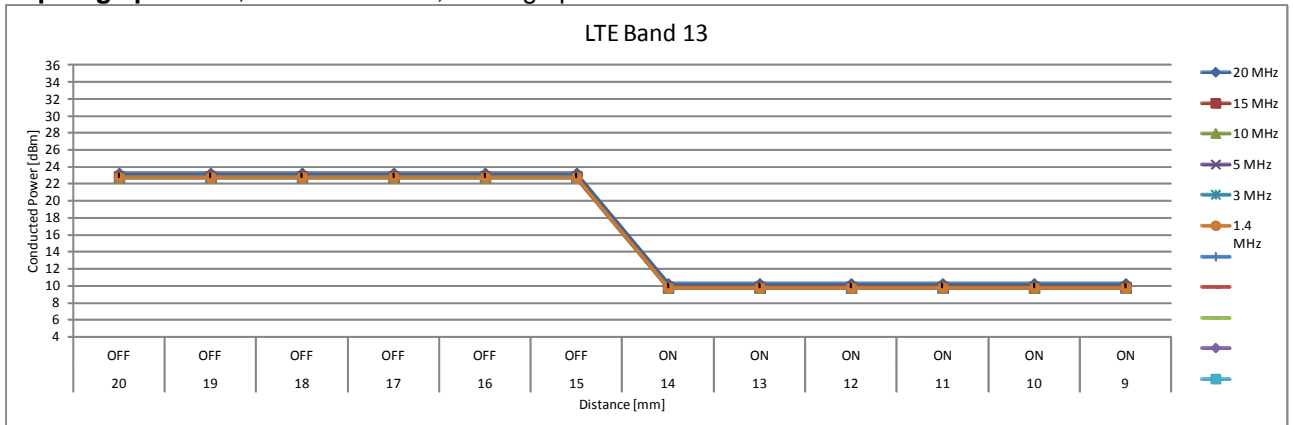

Top Edge position, Sensor 2 active, moving downward

