



TEST REPORT

Test report no.: 1-4254/12-76-07



Testing laboratory

CETECOM ICT Services GmbH
Untertuerkheimer Strasse 6 – 10
66117 Saarbruecken / Germany
Phone: + 49 681 5 98 - 0
Fax: + 49 681 5 98 - 9075
Internet: <http://www.cetecom.com>
e-mail: ict@cetecom.com

Accredited Testing Laboratory:

The testing laboratory (area of testing) is accredited according to DIN EN ISO/IEC 17025 (2005) by the Deutsche Akkreditierungsstelle GmbH (DAkkS). The accreditation is valid for the scope of testing procedures as stated in the accreditation certificate with the registration number: D-PL-12076-01-01
Area of Testing: Radio/Satellite Communications

Applicant

Sony Mobile Communications AB
Nya Vattentornet
22188 Lund / SWEDEN
Phone: +46 46 19 30 00
Fax: +46 46 19 32 95
Contact: Håkan Sjöberg
e-mail: hakan.sjoberg@sonymobile.com
Phone: +46 46 19 35 59

Manufacturer

Sony Mobile Communications AB
Nya Vattentornet
22188 Lund / SWEDEN

Test standard/s

47 CFR Part 15 Title 47 of the Code of Federal Regulations; Chapter I
Part 15 - Radio frequency devices
RSS - 210 Issue 8 Spectrum Management and Telecommunications - Radio Standards Specification
Low-power Licence-exempt Radiocommunication Devices (All Frequency Bands);
Category I Equipment

For further applied test standards please refer to section 3 of this test report.

Test Item

Kind of test item: Tablet PC GPRS/EGPRS 850/900/1800/1900; UMTS HSPA FDDI/V/VI/XIX; LTE FDD1/19/21; WLAN a/b/g/n; BT 3.1; BT LE; RFID; FM Rx; A-GPS
Model name: TM-0000-BV
FCC ID: PY7 TM-0000
IC: 4170B-TM0000
Frequency: ISM band 2400 MHz to 2483.5 MHz
(lowest channel 00 – 2402 MHz; highest channel 39 – 2480 MHz)
Technology tested: Bluetooth® LE
Antenna: Integrated PCB antenna
Power Supply: 3.7V DC by Li - polymer battery
Temperature Range: -20°C to +55°C

Test report authorised:

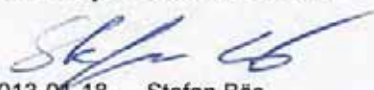
2013-01-18 Stefan Bös
Senior Testing Manager

Test performed:

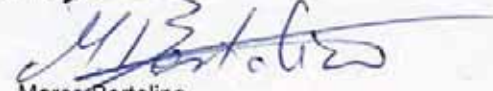
2013-01-18 Marco Bertolino
Testing Manager

1 Table of contents

1	Table of contents	2
2	General information	3
2.1	Notes and disclaimer	3
2.2	Application details	3
3	Test standard/s	3
3.1	Measurement guidance	3
4	Test environment	4
5	Test item	4
6	Test laboratories sub-contracted	4
7	Summary of measurement results	5
8	RF measurements	6
8.1	Description of test setup	6
8.1.1	Radiated measurements	6
8.1.2	Conducted measurements	7
8.2	Additional comments	7
8.3	RSP100 test report cover sheet / performance test data	8
9	Measurement results	9
9.1	Antenna gain	9
9.2	Power spectral density	10
9.3	Carrier frequency separation	13
9.4	Number of hopping channels	15
9.5	Time of occupancy (dwell time)	17
9.6	Spectrum bandwidth of a FHSS system – 6 dB bandwidth	18
9.7	Spectrum bandwidth of a FHSS system – 20 dB bandwidth	21
9.8	Maximum output power	24
9.9	Band edge compliance conducted	27
9.10	Band edge compliance radiated	30
9.11	TX spurious emissions conducted	32
9.12	TX spurious emissions radiated	35
9.13	RX spurious emissions radiated	46
9.14	Spurious emissions radiated < 30 MHz	50
9.15	Spurious emissions conducted < 30 MHz	52
10	Test equipment and ancillaries used for tests	55
11	Observations	56
Annex A	Photographs of the test setup	57
Annex B	External photographs of the EUT	60
Annex C	Internal photographs of the EUT	68
Annex D	Document history	107
Annex E	Further information	107
Annex F	Accreditation Certificate	108

2 General information

2.1 Notes and disclaimer

The test results of this test report relate exclusively to the test item specified in this test report. CETECOM ICT Services GmbH does not assume responsibility for any conclusions and generalizations drawn from the test results with regard to other specimens or samples of the type of the equipment represented by the test item.

The test report may only be reproduced or published in full. Reproduction or publication of extracts from the report requires the prior written approval of CETECOM ICT Services GmbH.

The testing service provided by CETECOM ICT Services GmbH has been rendered under the current "General Terms and Conditions for CETECOM ICT Services GmbH".

CETECOM ICT Services GmbH will not be liable for any loss or damage resulting from false, inaccurate, inappropriate or incomplete product information provided by the customer.

Under no circumstances does the CETECOM ICT Services GmbH test report include any endorsement or warranty regarding the functionality, quality or performance of any other product or service provided.

Under no circumstances does the CETECOM ICT Services GmbH test report include or imply any product or service warranties from CETECOM ICT Services GmbH, including, without limitation, any implied warranties of merchantability, fitness for purpose, or non-infringement, all of which are expressly disclaimed by CETECOM ICT Services GmbH.

All rights and remedies regarding vendor's products and services for which CETECOM ICT Services GmbH has prepared this test report shall be provided by the party offering such products or services and not by CETECOM ICT Services GmbH.

In no case this test report can be considered as a Letter of Approval.

2.2 Application details

Date of receipt of order:	2012-12-14
Date of receipt of test item:	2013-01-07
Start of test:	2013-01-07
End of test:	2013-01-18
Person(s) present during the test:	-/-

3 Test standard/s

Test standard	Date	Test standard description
47 CFR Part 15	2010-10	Title 47 of the Code of Federal Regulations; Chapter I Part 15 - Radio frequency devices
RSS - 210 Issue 8	2010-12	Spectrum Management and Telecommunications - Radio Standards Specification Low-power Licence-exempt Radiocommunication Devices (All Frequency Bands): Category I Equipment

3.1 Measurement guidance

DTS : KDB 558074	2012-04	Guidance for Performing Compliance Measurements on Digital Transmission Systems (DTS) Operating Under §15.247
------------------	---------	---

4 Test environment

Temperature:	T_{nom}	+22 °C during room temperature tests
	T_{max}	+55 °C during high temperature tests
	T_{min}	-20 °C during low temperature tests
Relative humidity content:		42 %
Barometric pressure:		not relevant for this kind of testing
Power supply:	V_{nom}	3.7 V DC by Li - polymer battery
	V_{max}	4.2 V
	V_{min}	3.3 V

5 Test item

Kind of test item	:	Tablet PC GPRS/EGPRS 850/900/1800/1900; UMTS HSPA FDDI/V/VI/XIX; LTE FDD1/19/21; WLAN a/b/g/n; BT 3.1; BT LE; RFID; FM Rx; A-GPS
Type identification	:	TM-0000-BV
S/N serial number	:	Radiated unit: CB5A1MD99N Conducted unit: CB5A1MD98S
HW hardware status	:	AP
SW software status	:	10.1.E.0.61
Frequency band [MHz]	:	ISM band 2400 MHz to 2483.5 MHz (lowest channel 00 – 2402 MHz; highest channel 39 – 2480 MHz)
Type of radio transmission	:	DSSS, FHSS
Use of frequency spectrum	:	
Type of modulation	:	GFSK
Number of channels	:	40
Antenna	:	Integrated PCB antenna
Power supply	:	3.7 V DC by Li - polymer battery
Temperature range	:	-20°C to +55 °C

6 Test laboratories sub-contracted

None

7 Summary of measurement results

- No deviations from the technical specifications were ascertained
 There were deviations from the technical specifications ascertained

TC Identifier	Description	Verdict	Date	Remark
RF-Testing	CFR Part 15 RSS 210, Issue 8, Annex 8	Passed	2013-01-18	-/-

Test specification clause	Test case	Temperature conditions	Power source voltages	Mode	Pass	Fail	NA	NP	Remark
§15.247(b)(4) RSS 210 / A8.4(2)	Antenna gain	Nominal	Nominal	GFSK	<input checked="" type="checkbox"/>	<input type="checkbox"/>	<input type="checkbox"/>	<input type="checkbox"/>	complies
§15.247(e) RSS 210 / A8.2(b)	Power spectral density	Nominal	Nominal	GFSK	<input checked="" type="checkbox"/>	<input type="checkbox"/>	<input type="checkbox"/>	<input type="checkbox"/>	complies
§15.247(a)(1) RSS 210 / A8.1(b)	Carrier frequency separation	Nominal	Nominal	GFSK	<input checked="" type="checkbox"/>	<input type="checkbox"/>	<input type="checkbox"/>	<input type="checkbox"/>	complies
§15.247(a)(1) RSS 210 / A8.1(d)	Number of hopping channels	Nominal	Nominal	GFSK	<input checked="" type="checkbox"/>	<input type="checkbox"/>	<input type="checkbox"/>	<input type="checkbox"/>	complies
§15.247(a)(1)(iii) RSS 210 / A8.3(1)	Time of occupancy (dwell time)	Nominal	Nominal	GFSK	<input checked="" type="checkbox"/>	<input type="checkbox"/>	<input type="checkbox"/>	<input type="checkbox"/>	complies
§15.247(a)(2) RSS 210 / A8.2(a)	Spectrum bandwidth of a FHSS system 6 dB bandwidth	Nominal	Nominal	GFSK	<input checked="" type="checkbox"/>	<input type="checkbox"/>	<input type="checkbox"/>	<input type="checkbox"/>	complies
§15.247(a)(1) RSS 210	Spectrum bandwidth of a FHSS system 20 dB bandwidth	Nominal	Nominal	GFSK	<input checked="" type="checkbox"/>	<input type="checkbox"/>	<input type="checkbox"/>	<input type="checkbox"/>	complies
§15.247(b)(1) RSS-210 / A8.4(2)	Maximum output power	Nominal	Nominal	GFSK	<input checked="" type="checkbox"/>	<input type="checkbox"/>	<input type="checkbox"/>	<input type="checkbox"/>	complies
§15.247(d) RSS-210 / A8.5	Band edge compliance conducted	Nominal	Nominal	GFSK	<input checked="" type="checkbox"/>	<input type="checkbox"/>	<input type="checkbox"/>	<input type="checkbox"/>	complies
§15.205 RSS-210 / A8.5	Band edge compliance radiated	Nominal	Nominal	GFSK	<input checked="" type="checkbox"/>	<input type="checkbox"/>	<input type="checkbox"/>	<input type="checkbox"/>	complies
§15.247(d) RSS-210 / A8.5	TX spurious emissions conducted	Nominal	Nominal	GFSK	<input checked="" type="checkbox"/>	<input type="checkbox"/>	<input type="checkbox"/>	<input type="checkbox"/>	complies
§15.247(d) RSS-210 / A8.5	TX spurious emissions radiated	Nominal	Nominal	GFSK	<input checked="" type="checkbox"/>	<input type="checkbox"/>	<input type="checkbox"/>	<input type="checkbox"/>	complies
§15.109 RSS-Gen.	RX spurious emissions radiated	Nominal	Nominal	-/-	<input checked="" type="checkbox"/>	<input type="checkbox"/>	<input type="checkbox"/>	<input type="checkbox"/>	complies
§15.209(a) RSS-Gen	TX spurious emissions radiated < 30 MHz	Nominal	Nominal	GFSK	<input checked="" type="checkbox"/>	<input type="checkbox"/>	<input type="checkbox"/>	<input type="checkbox"/>	complies
§15.107(a)	Conducted emissions < 30 MHz	Nominal	Nominal	GFSK	<input checked="" type="checkbox"/>	<input type="checkbox"/>	<input type="checkbox"/>	<input type="checkbox"/>	complies

Note: NA = Not Applicable; NP = Not Performed

8 RF measurements

8.1 Description of test setup

8.1.1 Radiated measurements

The radiated measurements are performed in vertical and horizontal plane in the frequency range from 9 kHz to 25 GHz in semi-anechoic chambers. The EUT is positioned on a non-conductive support with a height of 0.80 m above a conductive ground plane that covers the whole chamber. The receiving antennas are confirmed with specifications ANSI C63.2-1996 clause 15 and ANSI C63.4-2009 clause 4.1.5. These antennas can be moved over the height range between 1.0 m and 4.0 m in order to search for maximum field strength emitted from EUT. The measurement distances between EUT and receiving antennas are indicated in the test setups for the various frequency ranges. For each measurement, the EUT is rotated in all three axes until the maximum field strength is received. The wanted and unwanted emissions are received by spectrum analysers where the detector modes and resolution bandwidths over various frequency ranges are set according to requirement ANSI C63-4-2009 clause 4.2.

Antennas are confirmed with ANSI C63.2-1996 item 15.

Semi anechoic chamber

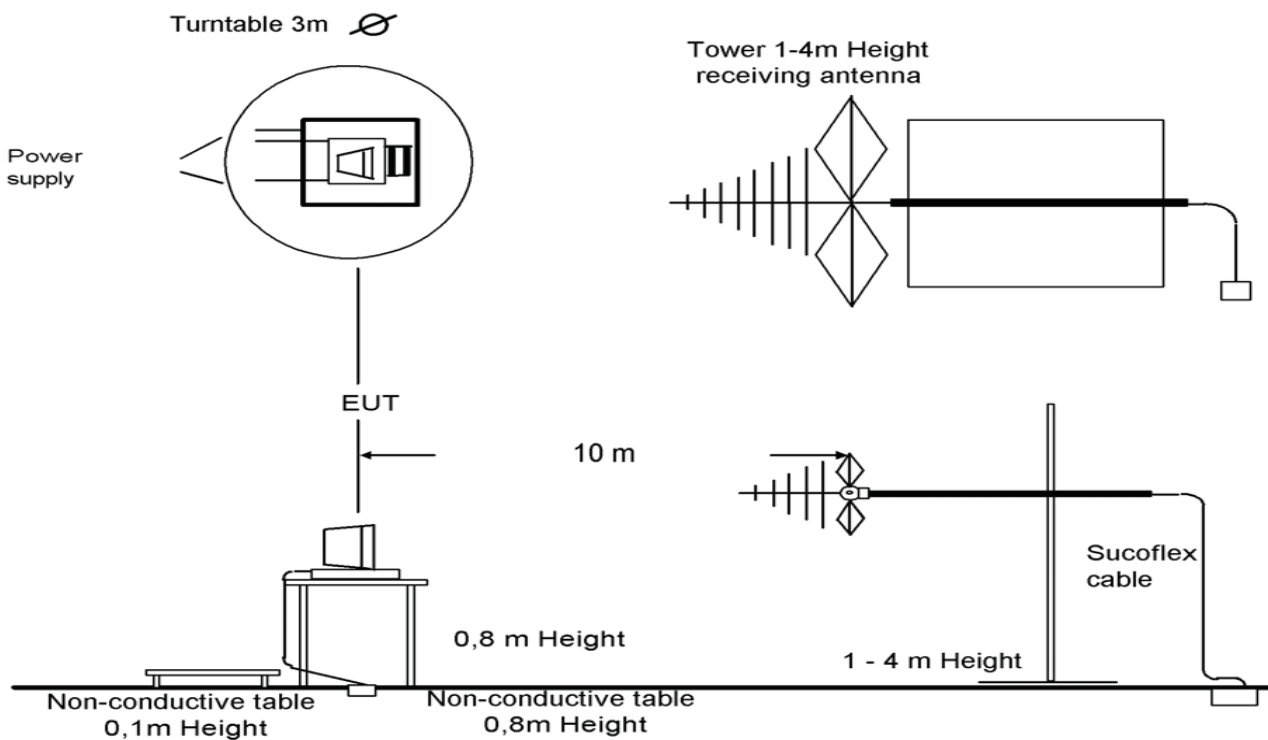

Picture 1: Diagram radiated measurements

9 kHz - 30 MHz:	active loop antenna
30 MHz – 1 GHz:	tri-log antenna
> 1 GHz:	horn antenna

All measurements are done in accordance with the Filing and Measurement Guidelines for Frequency Hopping Spread Spectrum Systems DA 00-705 and Appendix A “BLUETOOTH® APPROVALS”

The EUT is powered by an external power supply with nominal voltage. The signalling is performed from outside the chamber with a signalling unit (CMU200 or other) by air link using signalling antenna.

8.1.2 Conducted measurements

The EUT's RF signal is coupled out by the antenna connector which is supplied by the manufacturer. The signal is first 10dB attenuated before it is power divided (~6dB loss per branch). One of the signal paths is connected to the communication base Station (CMU200 or other), the other one is connected to the spectrum analyzer. The specific losses for both signal paths are first checked within a calibration. The measurement readings on the signalling unit/spectrum analyzer are corrected by the specific test set-up loss. The attenuator, power divider, signalling unit and the spectrum analyzer are impedance matched on 50 Ohm.

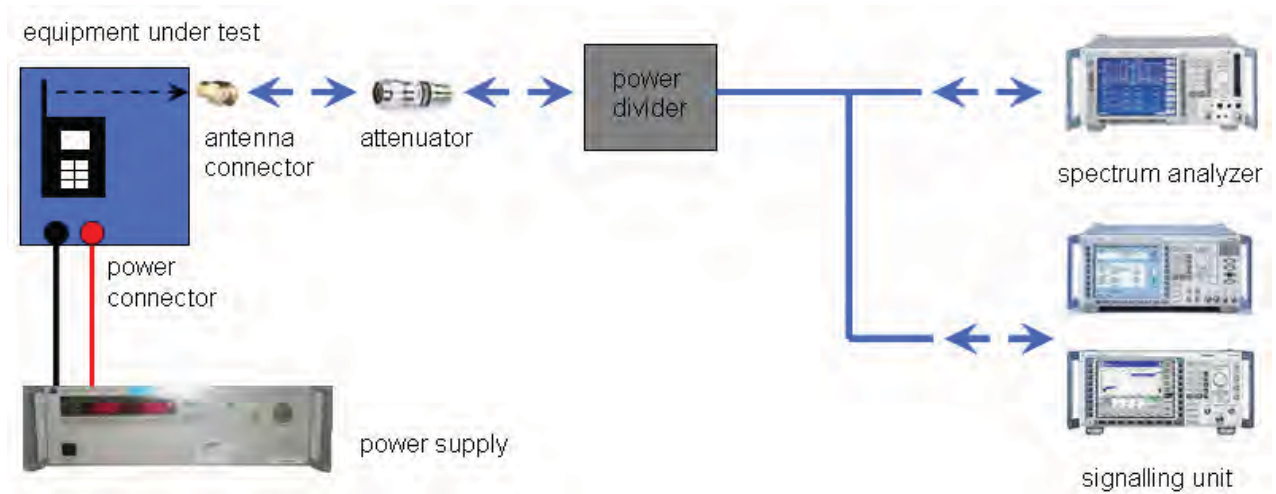

Picture 2: Diagram conducted measurements

8.2 Additional comments

The Bluetooth® word mark and logos are owned by the Bluetooth SIG Inc. and any use of such marks by Cetecom ICT Services GmbH is under license.

Reference documents: None

Special test descriptions: None

Configuration descriptions: TX tests: were performed with LE packets (37 byte payload) and static PRBS pattern.
RX/Standby tests: BT enabled, TX Idle

Test mode: Bluetooth LE Test mode enabled (EUT is controlled over CBT)
 Special software is used. EUT is transmitting pseudo random data by itself

8.3 RSP100 test report cover sheet / performance test data

Test report number	:	1-4254/12-76-07
Equipment model number	:	TM-0000-BV
Certification number	:	4170B-TM0000
Manufacturer (complete address)	:	Sony Mobile Communications AB Nya Vattentorget 22188 Lund / SWEDEN
Tested to radio standards specification no.	:	RSS 210, Issue 8
Open area test site IC No.	:	IC 3462C-1
Frequency range	:	ISM band 2400 MHz to 2483.5 MHz (lowest channel 00 – 2402 MHz; highest channel 39 – 2480 MHz)
RF-power [mW] (max.)	:	Cond.: 1.35 mW (GFSK) EIRP: 1.57 mW (GFSK)
Occupied bandwidth (99%-BW) [kHz]	:	1130 (GFSK)
Type of modulation	:	GFSK
Emission designator (TRC-43)	:	1M13KFXD (GFSK)
Antenna information	:	Integrated antenna
Transmitter spurious (worst case)	:	48 dBµV/m @ 12.75 GHz (noise floor)

ATTESTATION:

DECLARATION OF COMPLIANCE:

I attest that the testing was performed or supervised by me; that the test measurements were made in accordance with the above-mentioned Industry Canada standard(s); and that the equipment identified in this application has been subjected to all the applicable test conditions specified in the Industry Canada standards and all of the requirements of the standard have been met.

Laboratory manager:

2013-01-18

Marco Bertolino

Date

Name



Signature

9 Measurement results

9.1 Antenna gain

Measurement:

The antenna gain of the complete system is calculated by the difference of radiated power in EIRP and the conducted power of the module. For normal Bluetooth® devices, the GFSK modulation is used.

Measurement parameters:

Measurement parameter	
Detector:	Peak
Sweep time:	Auto
Resolution bandwidth:	3 MHz
Video bandwidth:	3 MHz
Span:	5 MHz
Trace-Mode:	Max hold

Limits:

FCC	IC
Antenna Gain	
6 dBi	

Results:

T_{nom}	V_{nom}	lowest channel 2402 MHz	middle channel 2440 MHz	highest channel 2480 MHz
Conducted power [dBm] Measured with GFSK modulation		0.77	1.15	1.31
Radiated power [dBm] Measured with GFSK modulation		1.97	0.45	-1.59
Gain [dBi] Calculated		1.2	-0.7	-2.9

Result: Passed

9.2 Power spectral density

Description:

Measurement of the power spectral density of a digital modulated system.

Measurement:

Measurement parameter	
Detector:	Peak
Sweep time:	Auto
Resolution bandwidth:	3 kHz
Video bandwidth:	10 kHz
Span:	≥ 1.5 DTS BW
Trace-Mode:	Max Hold

Limits:

FCC	IC
Power Spectral Density	
For digitally modulated systems the transmitter power spectral density conducted from the transmitter to the antenna shall not be greater than 8 dBm in any 3 kHz band during any time interval of continuous transmission or over 1.0 second if the transmission exceeds 1.0-second duration.	

Results:

Modulation	Power spectral density		
	2402 MHz	2440 MHz	2480 MHz
Frequency			
[dBm / 3kHz]	-15.05	-14.55	-14.56
Measurement uncertainty	± 1.5 dB		

Plots:

Plot 1: lowest channel

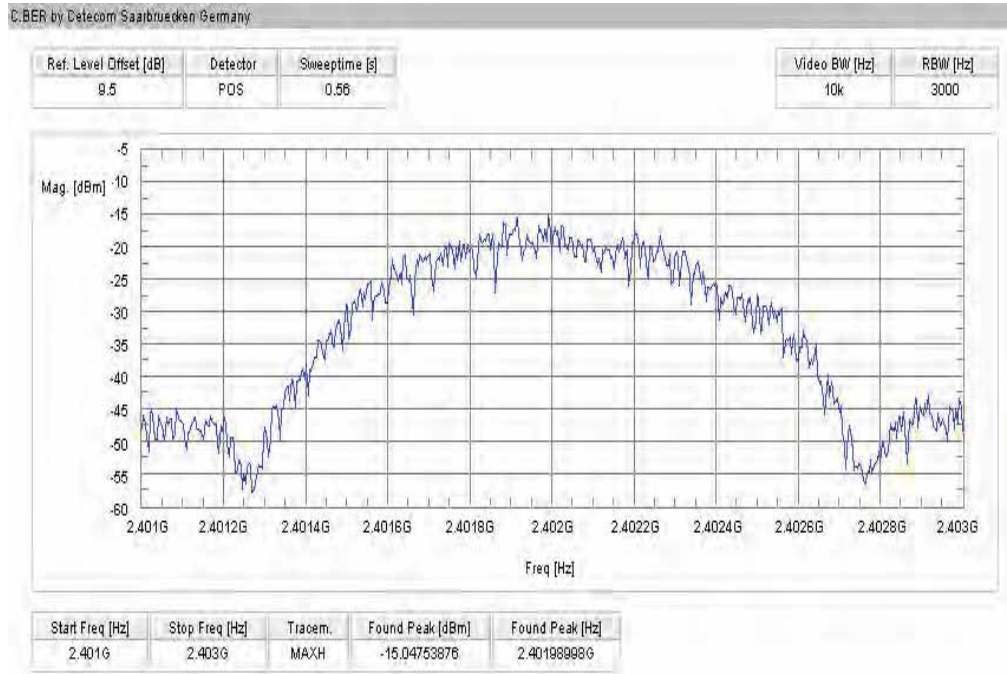

Plot 2: mid channel

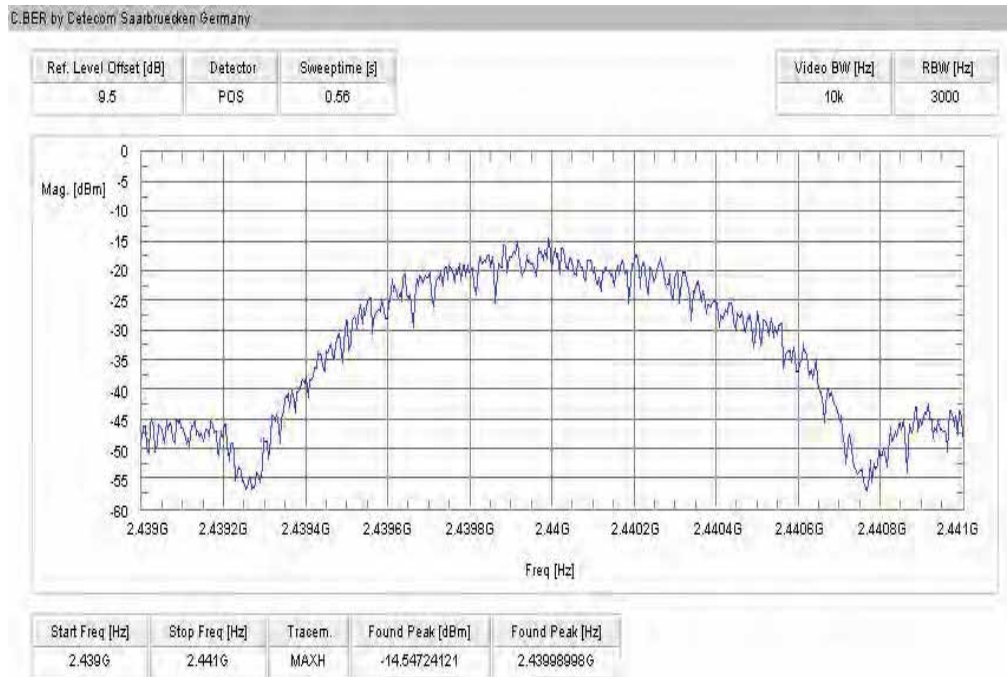

Plot 3: highest channel

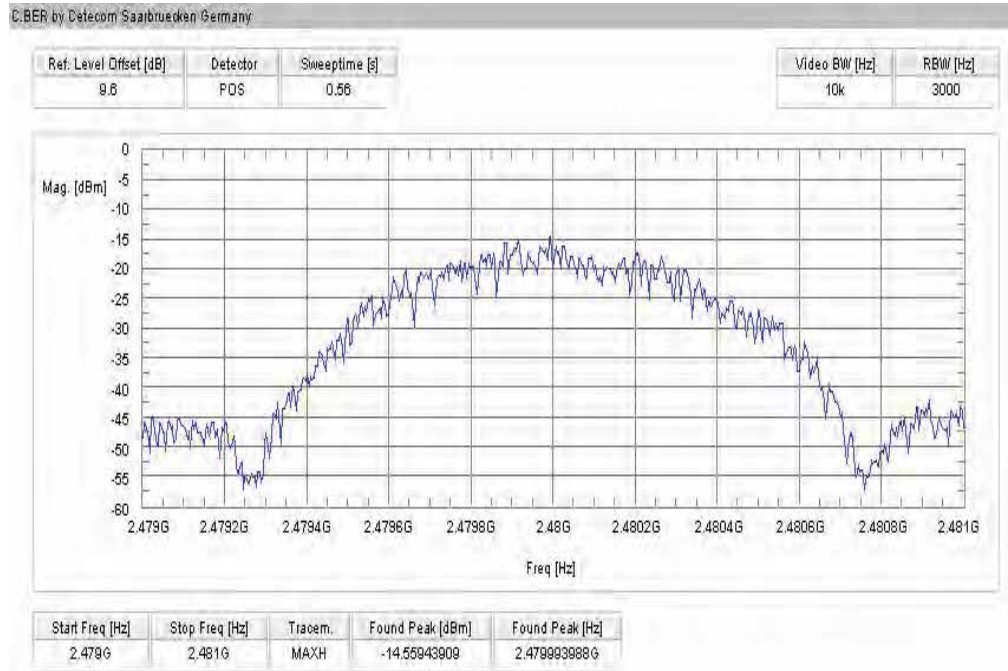

9.3 Carrier frequency separation

Description:

Measurement of the carrier frequency separation of a hopping system. We use GFSK modulation to show compliance. EUT in hopping mode.

Measurement:

Measurement parameter	
Detector:	Peak
Sweep time:	Auto
Resolution bandwidth:	100 kHz
Video bandwidth:	100 kHz
Span:	4 MHz
Trace-Mode:	Max Hold

Limits:

FCC	IC
Carrier Frequency Separation	
Minimum 25 kHz or two-thirds of the 20 dB bandwidth of the hopping system whichever is greater.	

Result:

Carrier frequency separation	~ 2 MHz
------------------------------	---------

Result: Passed

Plot:

Plot 1: Carrier Frequency Separation

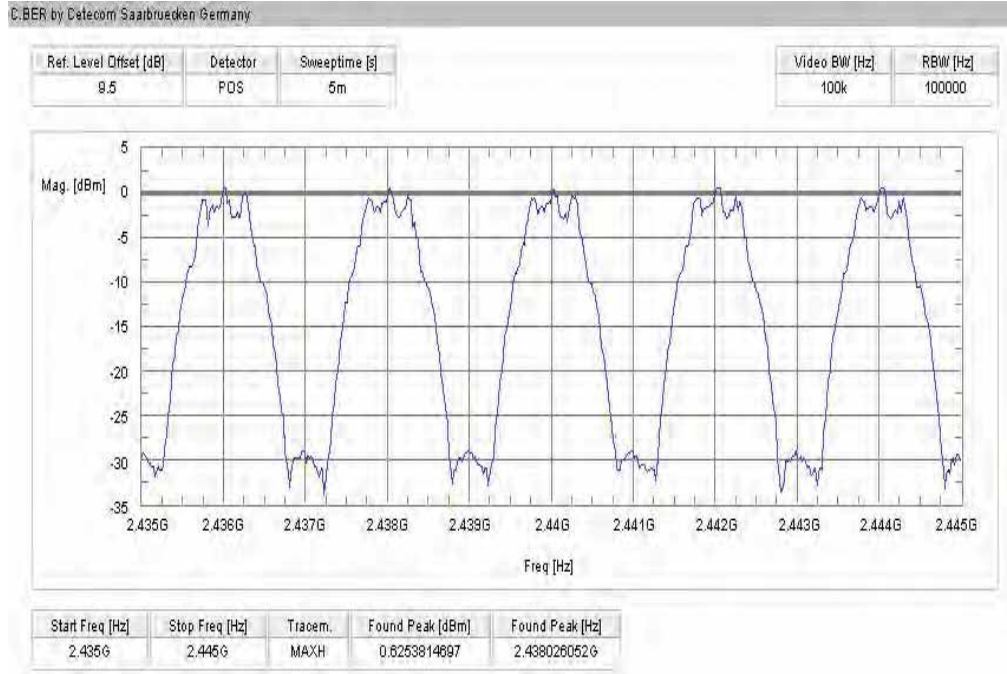

9.4 Number of hopping channels

Description:

Measurement of the total number of used hopping channels. The number of hopping channels is constant for all modulation-modes. We use GFSK modulation to show compliance. EUT in hopping mode.

Measurement:

Measurement parameter	
Detector:	Peak
Sweep time:	Auto
Resolution bandwidth:	500 kHz
Video bandwidth:	500 kHz
Span:	Plot 1: 2400 – 2445 MHz Plot 2: 2445 – 2485 MHz
Trace-Mode:	Max Hold

Limits:

FCC	IC
Number of hopping channels	
At least 15 non overlapping hopping channels	

Result:

Number of hopping channels	40
----------------------------	----

Result: Passed

Plots:

Plot 1: Number of hopping channels

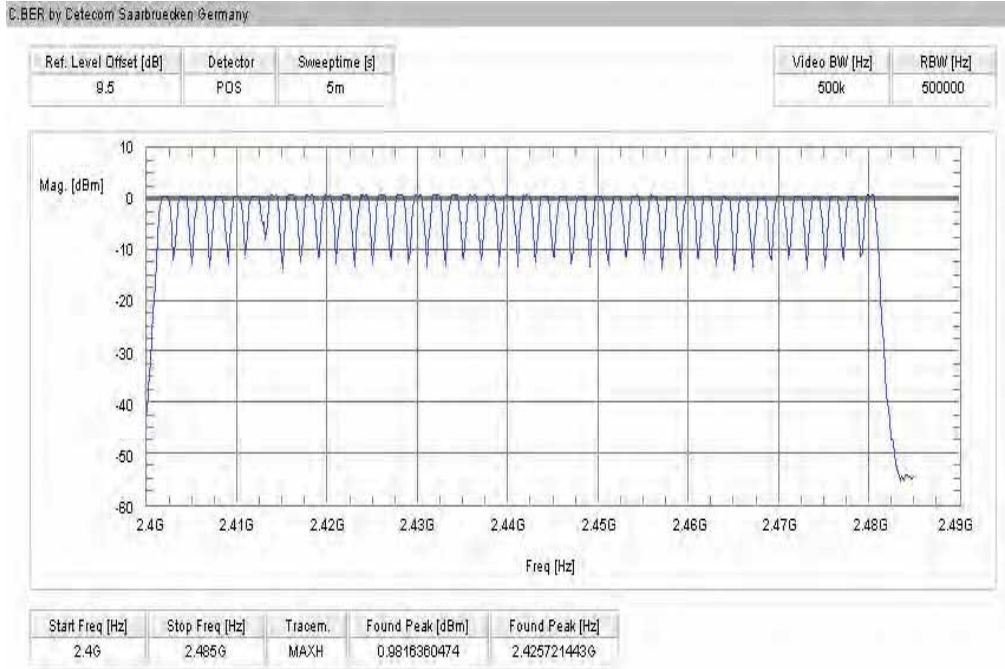

9.5 Time of occupancy (dwell time)

Measurement:

Measuring/calculation of the pulse width in data transmit mode on one hopping channel for a Bluetooth® LE device.

Measurement parameters:

Detector: Peak
 Video bandwidth: 1 MHz
 Resolution bandwidth: 1 MHz
 Span: Zero Span
 Trace: Video triggered

For Bluetooth® LE devices:

Time slot length: 625us
 Number of channels: 40
 Number of time slots per second: 1600/s
 Max. number of transmissions per channel in 1 s: $1600/s / 40 = 40$
 Max. number of transmissions per channel in 16 s: $40 \times 16 = 640$
 Period: Number of channels \times 0.4s = 16s

Under normal test conditions only	400 ms within in a period
-----------------------------------	---------------------------

Results:

Dwell time = standard test packet pulse width*) \times number of transmission per channel in 15.6 seconds

Packet type	standard test packet pulse width [ms]	number of hops in 16 sec	calculated dwell time[ms]
Data Transmit mode	0.376	640	241

*) For Bluetooth® LE devices no measurements are mandatory due to the fixed requirements of the Bluetooth® Core Specification. The standard test packet is defined as:

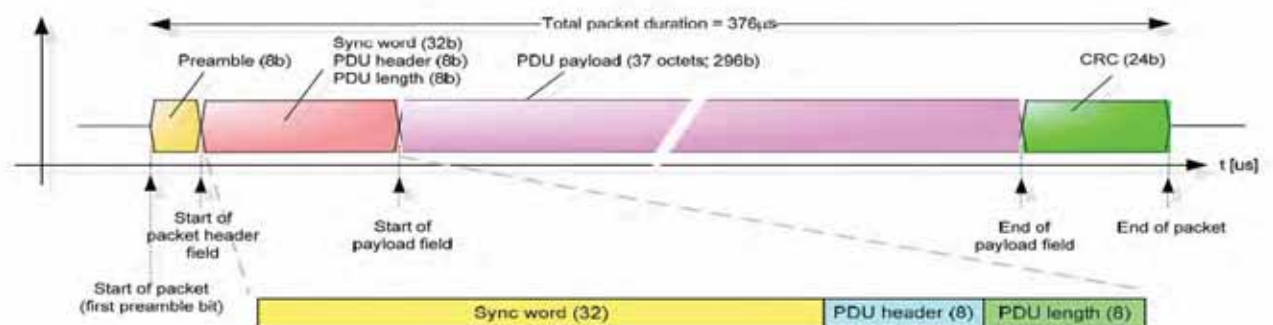

Result: Passed

9.6 Spectrum bandwidth of a FHSS system – 6 dB bandwidth

Description:

Measurement of the 6 dB bandwidth of the modulated signal.

Measurement:

Measurement parameter	
Detector:	Peak
Sweep time:	2 s
Resolution bandwidth:	20 kHz
Video bandwidth:	100 kHz
Span:	See plot!
Trace-Mode:	Max Hold

Limits:

FCC	IC
Spectrum bandwidth of a FHSS system – 6 dB bandwidth	
> 500 kHz	

Results:

Modulation	6 dB BANDWIDTH [kHz]		
	2402 MHz	2440 MHz	2480 MHz
Frequency			
GFSK	637	643	637
Measurement uncertainty	± 20 kHz		

Result: Passed

Plots:

Plot 1: lowest channel



Plot 2: mid channel

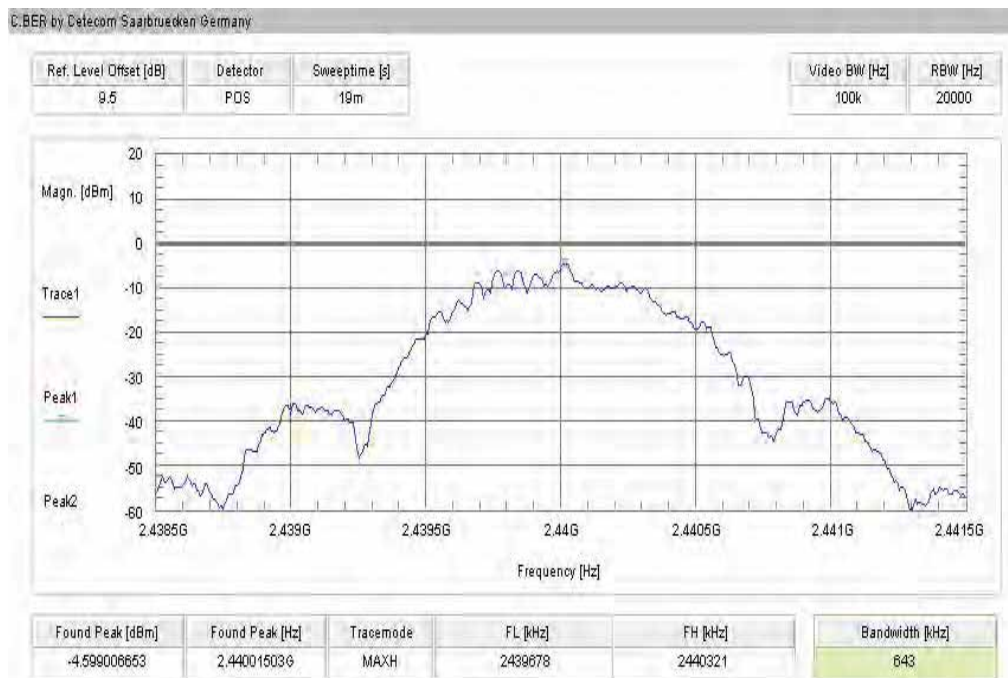

Plot 3: highest channel

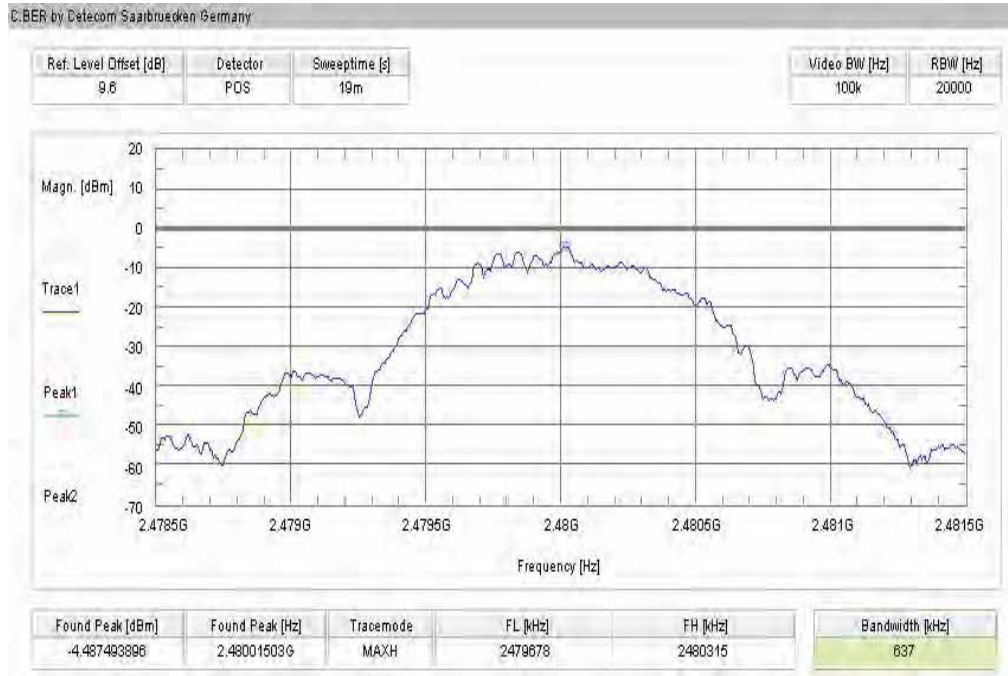

9.7 Spectrum bandwidth of a FHSS system – 20 dB bandwidth

Description:

Measurement of the 20 dB bandwidth of the modulated signal. The measurement is performed according to the "Measurement Guidelines" (DA 00-705, March 30, 2000). EUT in single channel mode.

Measurement:

Measurement parameter	
Detector:	Peak
Sweep time:	2 s
Resolution bandwidth:	30 kHz
Video bandwidth:	100 kHz
Span:	See plot!
Trace-Mode:	Max Hold

Limits:

FCC	IC
Spectrum bandwidth of a FHSS system – 20 dB bandwidth	
Bandwidth < 3/2 * Channel spacing	

Results:

Modulation Frequency	20 dB BANDWIDTH [kHz]		
	2402 MHz	2440 MHz	2480 MHz
GFSK	1130	1130	1122
Measurement uncertainty	± 30 kHz		

Result: Passed

Plots:

Plot 1: lowest channel



Plot 2: mid channel



Plot 3: highest channel



9.8 Maximum output power

Description:

Measurement of the maximum output power conducted and radiated. EUT in single channel mode.

Measurement:

Measurement parameter	
Detector:	Peak
Sweep time:	Auto
Resolution bandwidth:	3 MHz
Video bandwidth:	3 MHz
Span:	3 MHz
Trace-Mode:	Max Hold

Limits:

FCC	IC
Maximum output power	
[Conducted: 0.125 W – antenna gain max. 6 dBi] Systems using more than 75 hopping channels: Conducted: 1.0 W – antenna gain max. 6 dBi	

Results:

Modulation	Maximum output power conducted [dBm]		
	2402 MHz	2440 MHz	2480 MHz
Frequency			
GFSK	0.77	1.15	1.31
Measurement uncertainty	± 1.5 dB		

Modulation	Maximum output power radiated - EIRP [dBm]		
	2402 MHz	2440 MHz	2480 MHz
Frequency			
GFSK	1.97	0.45	-1.59
Measurement uncertainty	± 3 dB		

*) - Values calculated with antenna gain

Result: Passed

Plots:

Plot 1: lowest channel

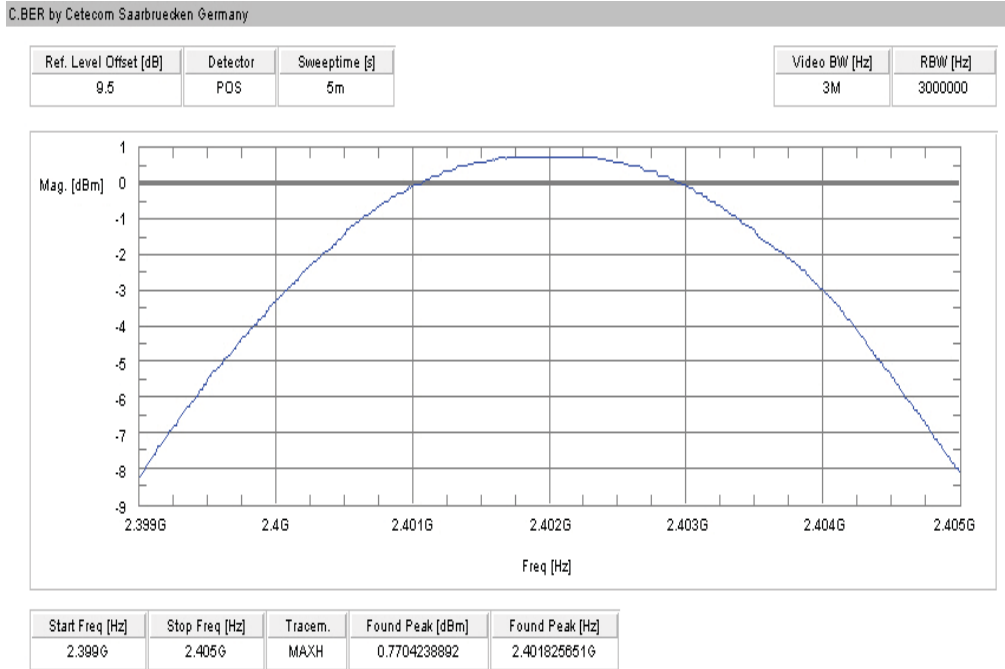

Plot 2: mid channel

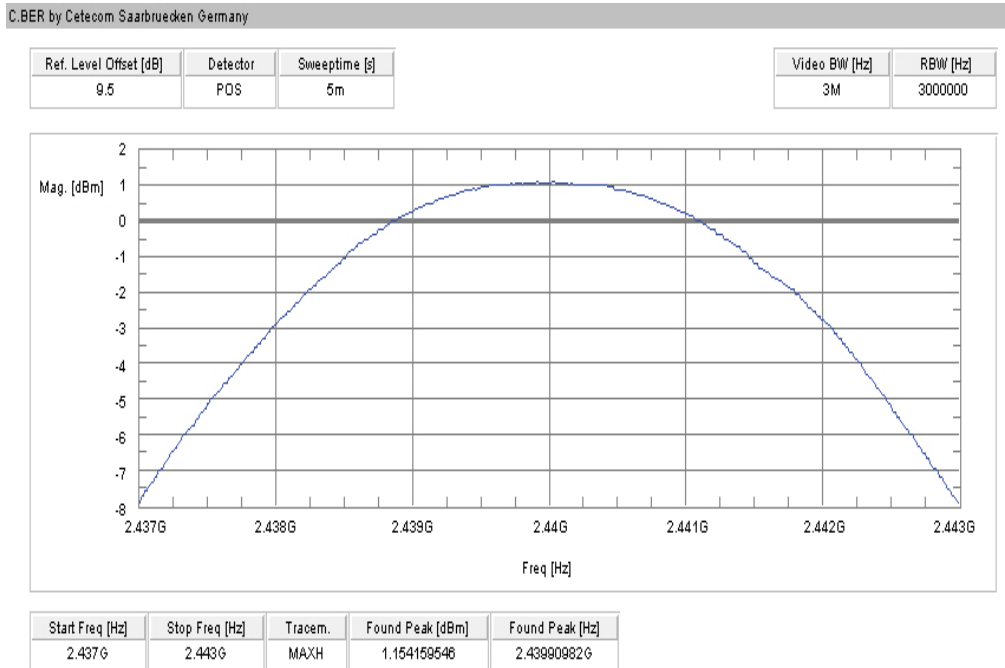

Plot 3: highest channel

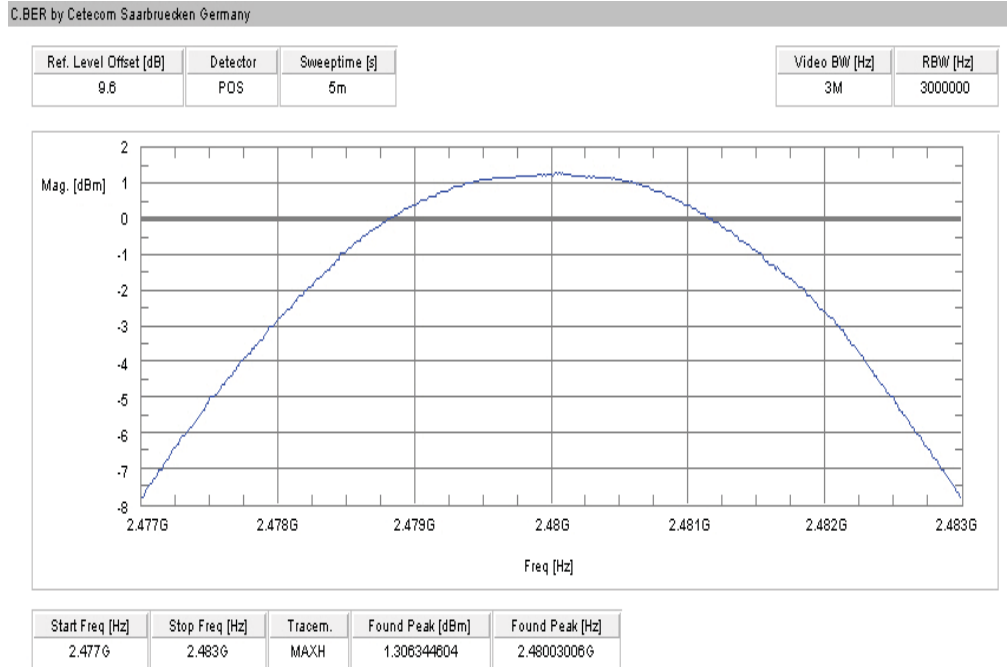

9.9 Band edge compliance conducted

Description:

Measurement of the conducted band edge compliance. EUT is measured at the lower and upper band edge in single channel and hopping mode. The measurement is repeated for all modulations.

Measurement:

Measurement parameter	
Detector:	Peak
Sweep time:	Auto
Resolution bandwidth:	100 kHz
Video bandwidth:	500 kHz
Span:	Lower Band Edge: 2395 – 2405 MHz Upper Band Edge: 2478 – 2489 MHz
Trace-Mode:	Max Hold

Limits:

FCC	IC
Band edge compliance conducted	
<p>In any 100 kHz bandwidth outside the frequency band in which the spread spectrum or digitally modulated intentional radiator is operating, the radio frequency power that is produced by the intentional radiator shall be at least 20 dB below that in the 100 kHz bandwidth within the band that contains the highest level of the desired power, based on either an RF conducted or a radiated measurement. Attenuation below the general limits specified in Section 15.209(a) is not required.</p>	

Result:

Scenario Modulation	Band edge compliance conducted [dB]
	GFSK
Lower band edge – hopping off	> 20 dB
Lower band edge – hopping on	> 20 dB
Upper band edge – hopping off	> 20 dB
Upper band edge – hopping on	> 20 dB
Measurement uncertainty	± 1.5 dB

Result: Passed

Plots:

Plot 1: Lower band edge – hopping on

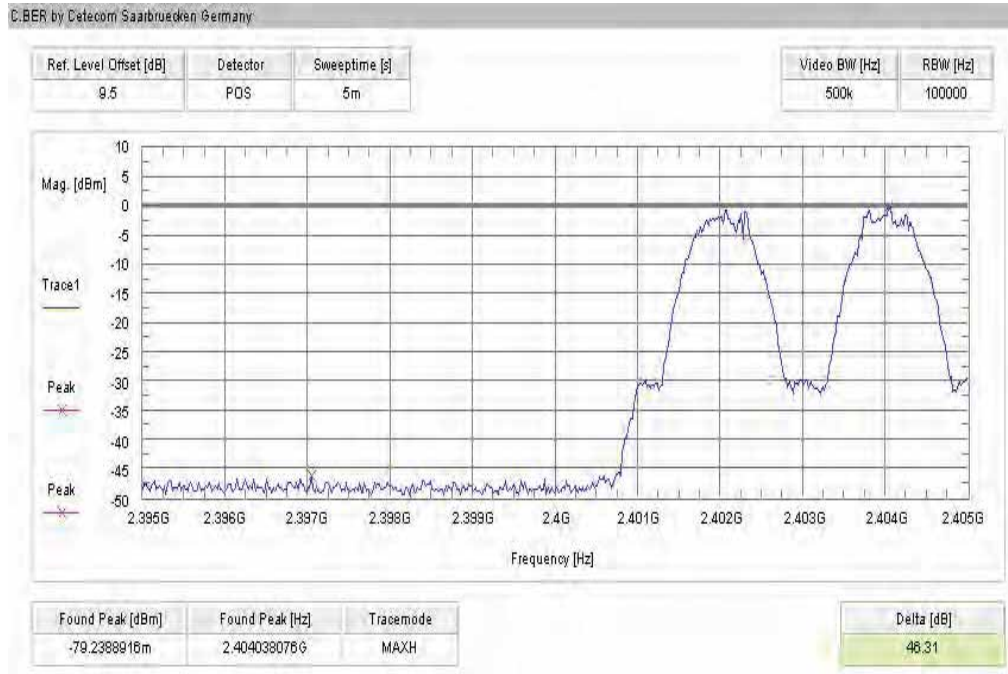

Plot 2: Upper band edge – hopping on

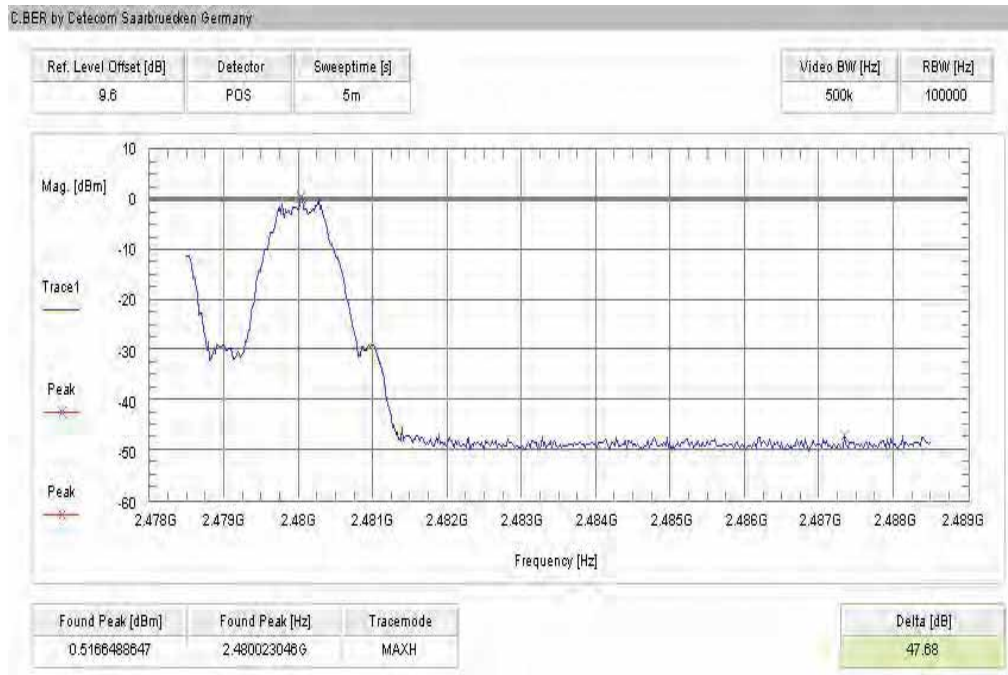

Plot 3: Lower band edge – hopping off

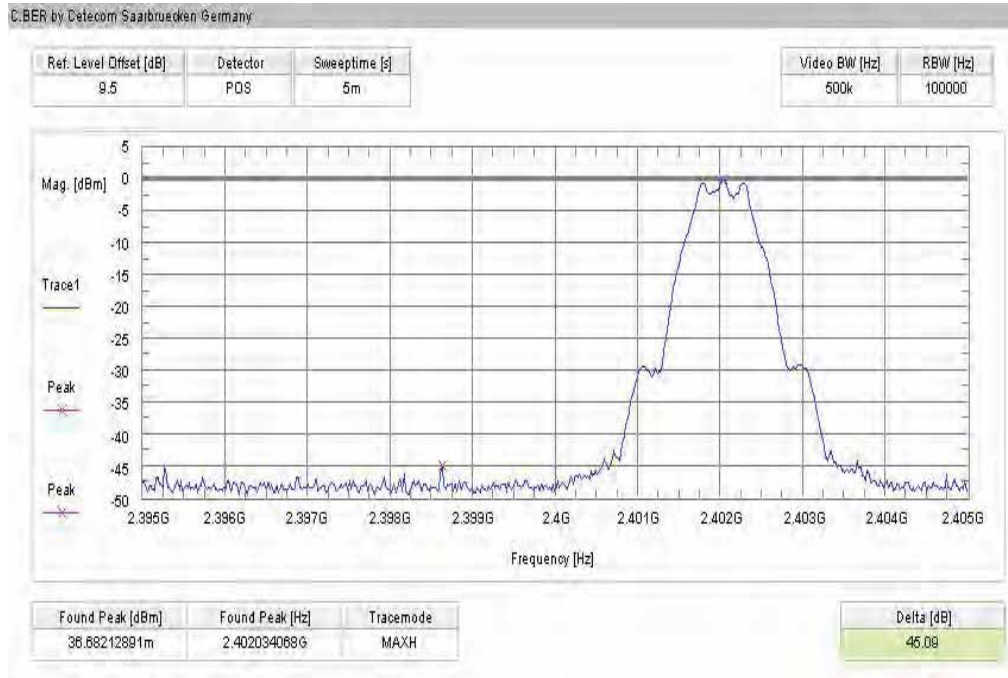

Plot 4: Upper band edge – hopping off

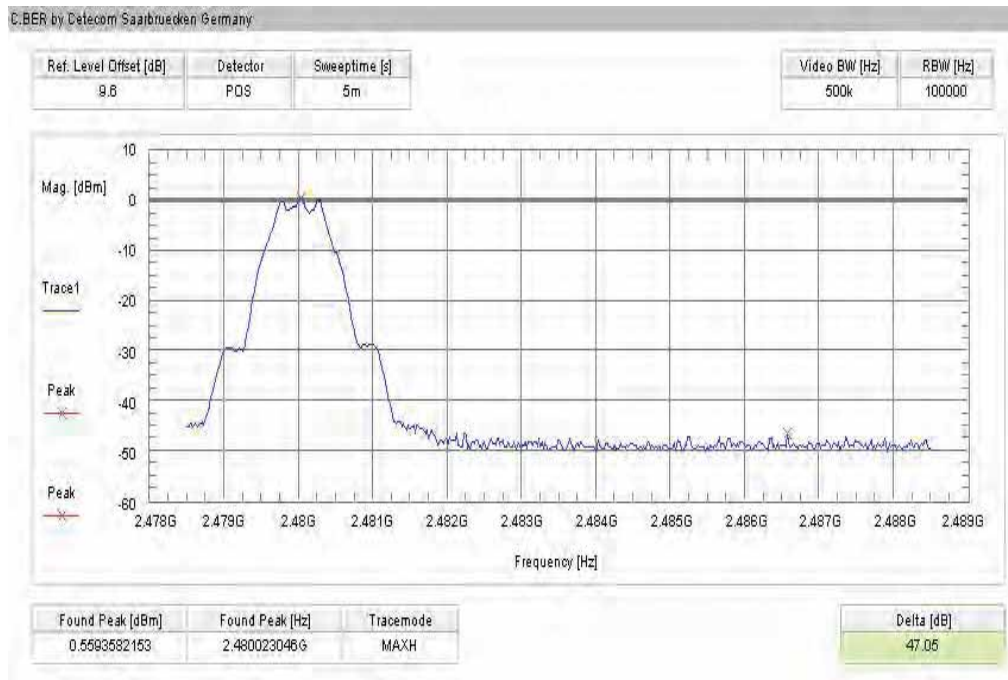

9.10 Band edge compliance radiated

Description:

Measurement of the radiated band edge compliance. The EUT is turned in the position that results in the maximum level at the band edge. Then a sweep over the corresponding restricted band is performed. The EUT is set to single channel mode and the transmit channel is channel 00 for the lower restricted band and channel 39 for the upper restricted band. The measurement is repeated for all modulations. Measurement distance is 3m.

Measurement:

Measurement parameter	
Detector:	Peak
Sweep time:	Auto
Resolution bandwidth:	1 MHz / 1 MHz
Video bandwidth:	10 Hz / 1 MHz
Span:	Lower Band: 2300 – 2400 MHz Upper Band: 2480 – 2500 MHz
Trace-Mode:	Max Hold

Limits:

FCC	IC
Band edge compliance radiated	
<p>In any 100 kHz bandwidth outside the frequency band in which the spread spectrum or digitally modulated intentional radiator is operating, the radio frequency power that is produced by the intentional radiator shall be at least 20 dB below that in the 100 kHz bandwidth within the band that contains the highest level of the desired power, based on either an RF conducted or a radiated measurement. Attenuation below the general limits specified in Section 15.209(a) is not required. In addition, radiated emissions which fall in the restricted bands, as defined in Section 15.205(a), must also comply with the radiated emission limits specified in Section 15.209(a) (see Section 5.205(c)).</p>	
74 dB μ V/m peak 54 dB μ V/m AVG	

Result:

Scenario	Band edge compliance radiated [dB μ V/m]
Modulation	GFSK
Lower restricted band	< 74 (peak) < 54 (average)
Upper restricted band	< 74 (peak) < 54 (average)
Measurement uncertainty	\pm 3 dB

Result: Passed

Plots:

Plot 1: Lower restricted band

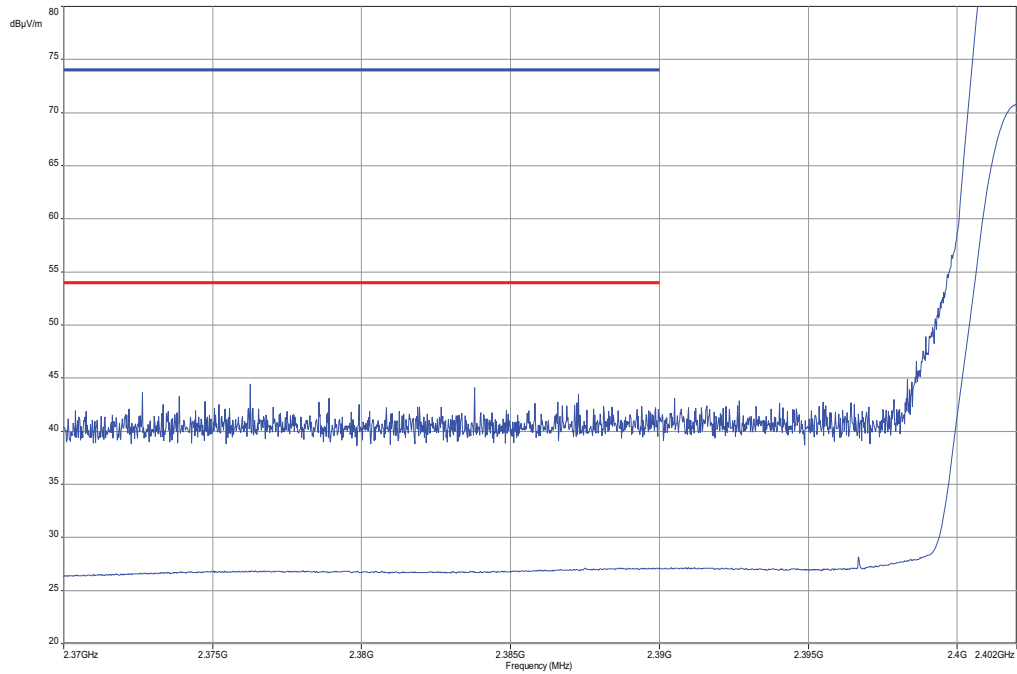

Plot 2: Upper restricted band

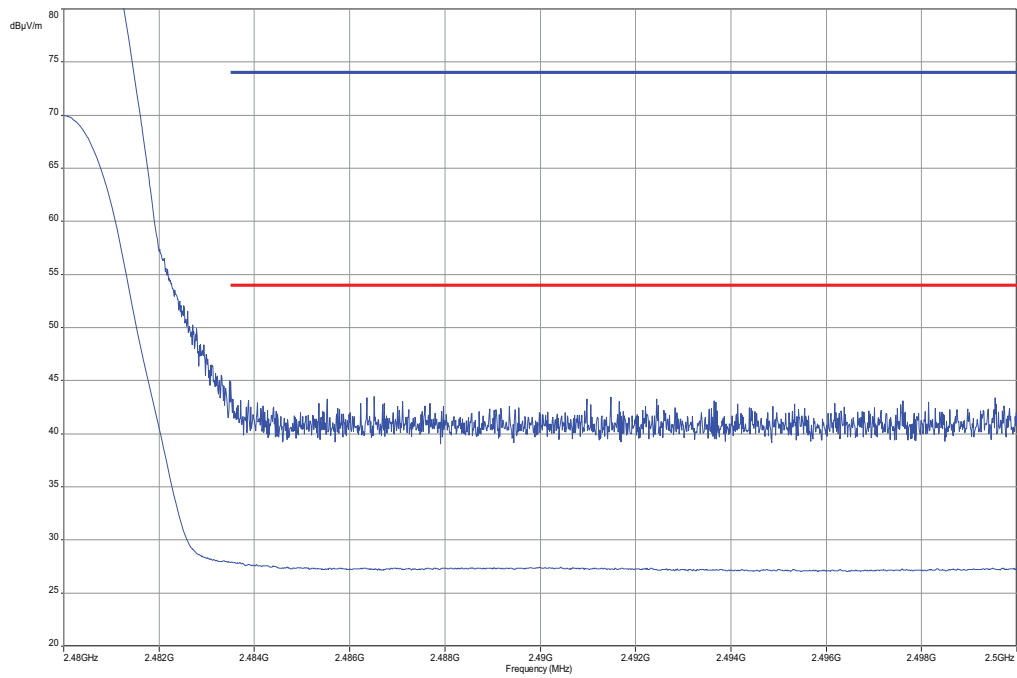

9.11 TX spurious emissions conducted

Description:

Measurement of the conducted spurious emissions in transmit mode. The EUT is set to single channel mode and the transmit channel is channel 00, channel 19 and channel 39. The measurement is repeated for all modulations.

Measurement:

Measurement parameter	
Detector:	Peak
Sweep time:	Auto
Resolution bandwidth:	100 kHz
Video bandwidth:	300 kHz or 500 kHz
Span:	9 kHz to 25 GHz
Trace-Mode:	Max Hold

Limits:

FCC	IC
TX spurious emissions conducted	
In any 100 kHz bandwidth outside the frequency band in which the spread spectrum or digitally modulated intentional radiator is operating, the radio frequency power that is produced by the intentional radiator shall be at least 20 dB below that in the 100 kHz bandwidth within the band that contains the highest level of the desired power, based on either an RF conducted or a radiated measurement. Attenuation below the general limits specified in Section 15.209(a) is not required	

Results:

TX spurious emissions conducted					
f [MHz]		amplitude of emission [dBm]	limit max. allowed emission power	actual attenuation below frequency of operation [dB]	results
2402		0.56	30 dBm		Operating frequency
<i>No critical peaks found! All detected emissions are more than 6 dB below the limit!</i>			-20 dBc		complies
2440		0.68	30 dBm		Operating frequency
<i>No critical peaks found! All detected emissions are more than 6 dB below the limit!</i>			-20 dBc		complies
2480		0.69	30 dBm		Operating frequency
<i>No critical peaks found! All detected emissions are more than 6 dB below the limit!</i>			-20 dBc		complies
Measurement uncertainty		± 3 dB			

Result: Passed

Plots:

Plot 1: lowest channel

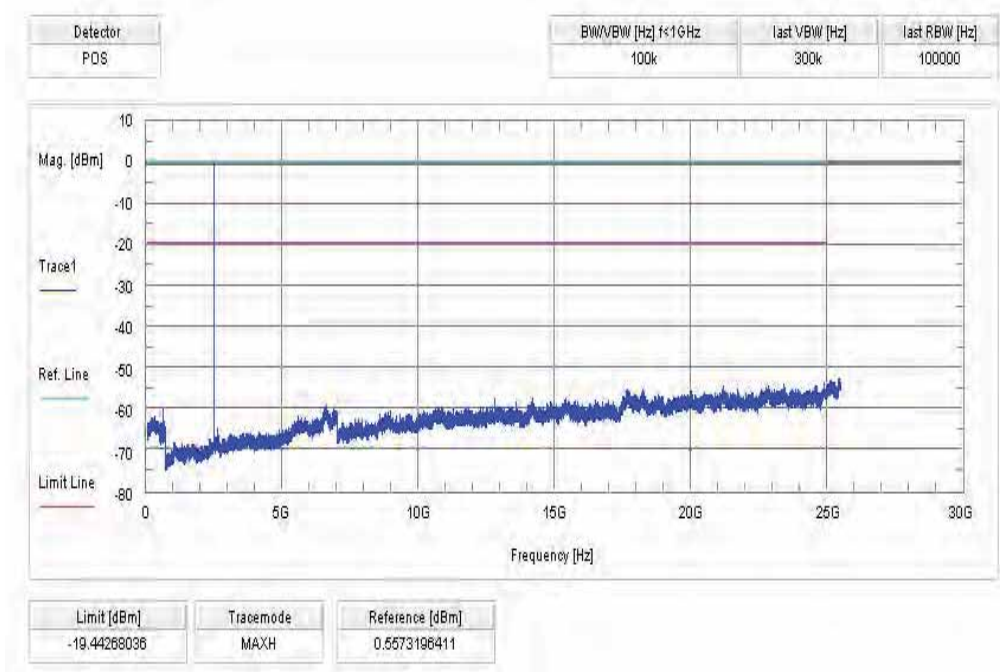

Plot 2: mid channel

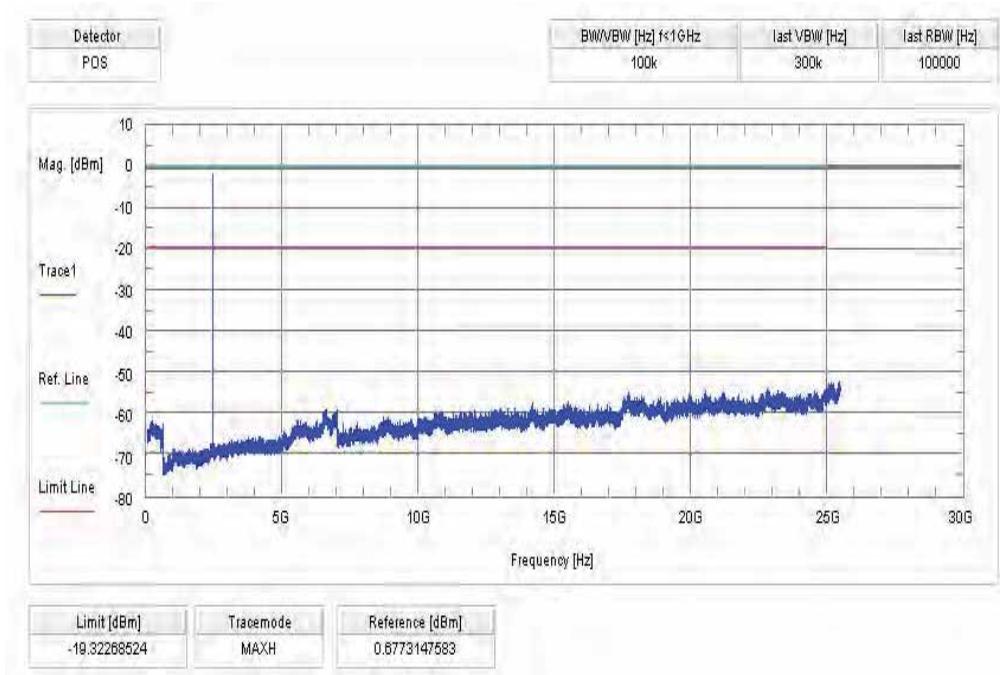

Plot 3: highest channel

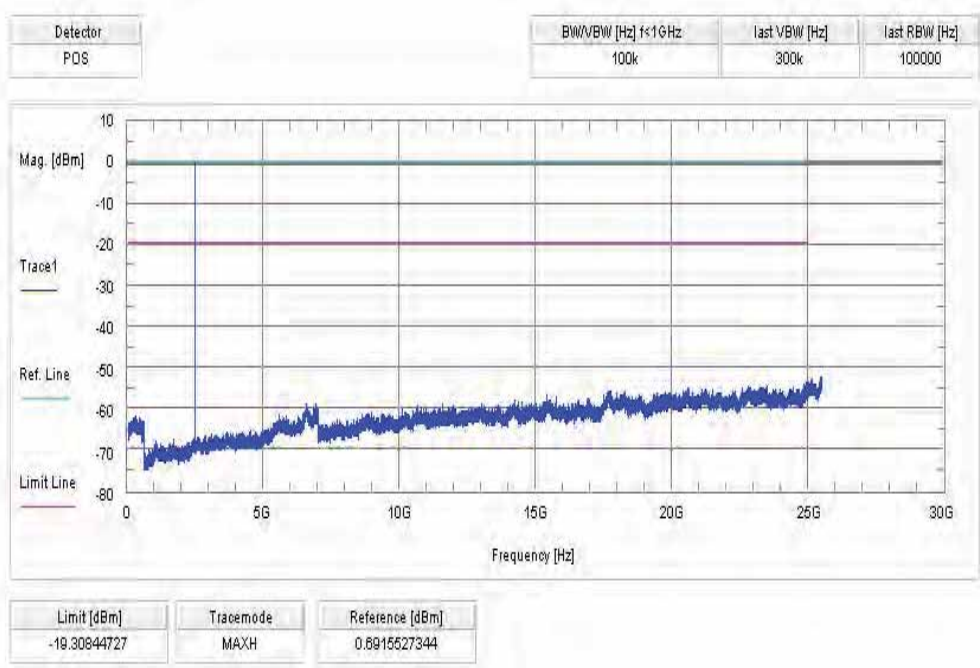

9.12 TX spurious emissions radiated

Description:

Measurement of the radiated spurious emissions in transmit mode. The EUT is set to single channel mode and the transmit channel is channel 00, channel 19 and channel 39. The measurement is performed in the mode with the highest output power.

Measurement:

Measurement parameter	
Detector:	Peak / Quasi Peak
Sweep time:	Auto
Resolution bandwidth:	F < 1 GHz: 100 kHz F > 1 GHz: 1 MHz
Video bandwidth:	Sweep: 100 kHz Remeasurement: 10 Hz
Span:	30 MHz to 26 GHz
Trace-Mode:	Max Hold
Measured Modulation:	GFSK

The modulation with the highest output power was used to perform the transmitter spurious emissions. If spurious were detected a re-measurement was performed on the detected frequency with each modulation.

Limits:

FCC		IC
TX spurious emissions radiated		
<p>In any 100 kHz bandwidth outside the frequency band in which the spread spectrum or digitally modulated intentional radiator is operating, the radio frequency power that is produced by the intentional radiator shall be at least 20 dB below that in the 100 kHz bandwidth within the band that contains the highest level of the desired power, based on either an RF conducted or a radiated measurement. Attenuation below the general limits specified in Section 15.209(a) is not required. In addition, radiated emissions which fall in the restricted bands, as defined in §15.205(a), must also comply with the radiated emission limits specified in §15.209(a) (see §15.205(c)).</p>		
§15.209		
Frequency (MHz)	Field strength (dBµV/m)	Measurement distance
30 - 88	30.0	10
88 - 216	33.5	10
216 - 960	36.0	10
Above 960	54.0	3

Results:

TX spurious emissions radiated [dBµV/m]								
2402 MHz			2440 MHz			2480 MHz		
F [MHz]	Detector	Level [dBµV/m]	F [MHz]	Detector	Level [dBµV/m]	F [MHz]	Detector	Level [dBµV/m]
For emissions below 1 GHz, please take a look at the table below the 1 GHz plot.			For emissions below 1 GHz, please take a look at the table below the 1 GHz plot.			For emissions below 1 GHz, please take a look at the table below the 1 GHz plot.		
No emissions detected above 1 GHz.			No emissions detected above 1 GHz.			No emissions detected above 1 GHz.		
Measurement uncertainty			± 3 dB					

Result: Passed

Plots:

Plot 1: 30 MHz to 1 GHz, lowest channel, vertical & horizontal polarization

Common Information

EUT: TM-0000-BV
 Serial Number: CB5A1MD99N
 Test Description: FCC part 15 class B @ 10m
 Operating Conditions: TX BT LE Ch. 0 + charging
 Operator Name: Hennemann
 Comment: AC: 115 V / 60 Hz

Scan Setup: STAN_Fin [EMI radiated]

Hardware Setup: Electric Field (NOS)
 Receiver: [ESCI 3]
 Level Unit: dBµV/m

Subrange	Step Size	Detectors	IF BW	Meas. Time	Preamp
30 MHz - 2 GHz	60 kHz	QPK	120 kHz	1 s	20 dB
		FCC_10m(B)_3			

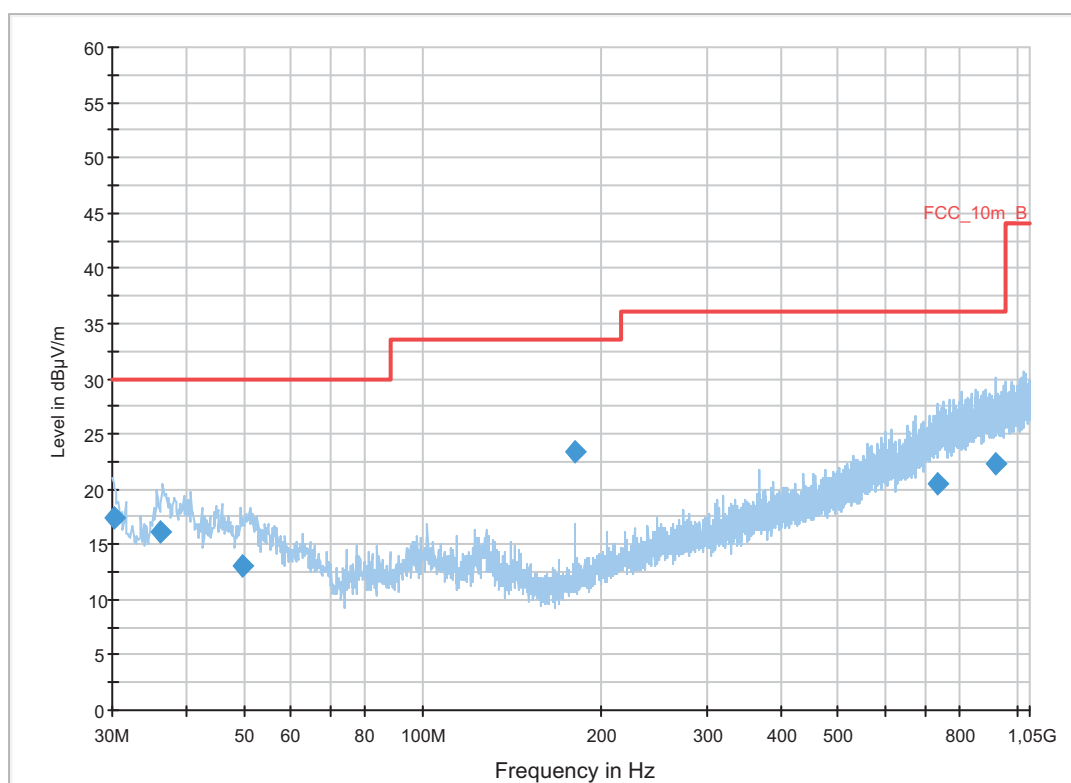

Final Result 1

Frequency (MHz)	QuasiPeak (dBµV/m)	Meas. Time (ms)	Bandwidth (kHz)	Height (cm)	Polarization	Azimuth (deg)	Corr. (dB)	Margin (dB)	Limit (dBµV/m)	Comment
30.271575	17.5	1000.0	120.000	129.0	V	280.0	12.5	12.5	30.0	
36.119250	16.1	1000.0	120.000	98.0	V	2.0	13.1	13.9	30.0	
49.782750	13.1	1000.0	120.000	98.0	V	2.0	13.4	16.9	30.0	
180.000300	23.4	1000.0	120.000	132.0	V	-3.0	10.4	10.1	33.5	
732.519300	20.5	1000.0	120.000	170.0	V	272.0	23.3	15.5	36.0	
921.397500	22.3	1000.0	120.000	170.0	H	93.0	25.3	13.7	36.0	

Plot 2: 1 GHz to 12.75 GHz, lowest channel, vertical & horizontal polarization

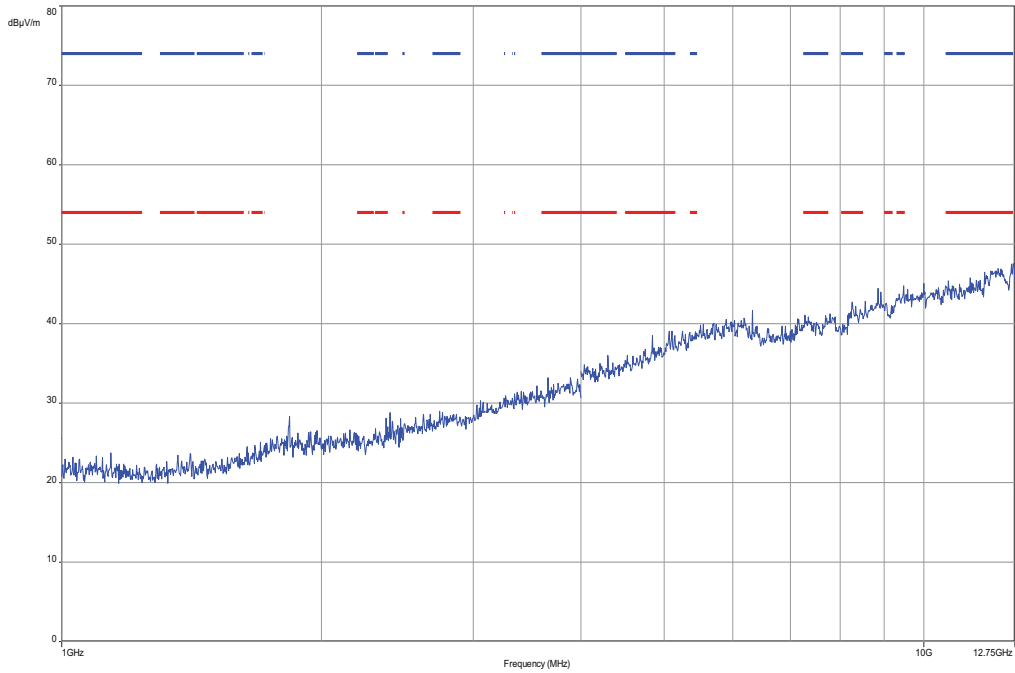

Carrier suppressed with a 2.4 GHz-band rejection filter.

Plot 3: 12 GHz to 18 GHz, lowest channel, vertical & horizontal polarization

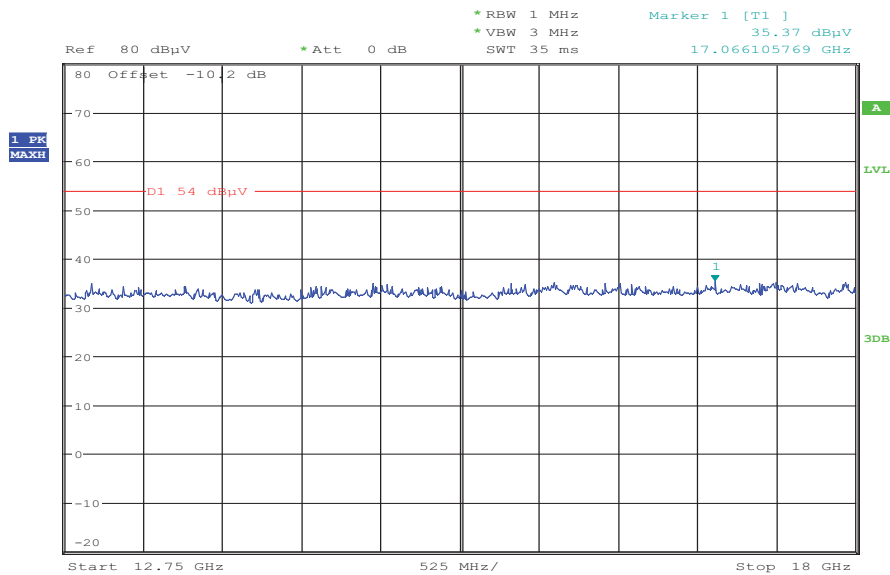

Date: 18.JAN.2013 12:33:54

Plot 4: 18 GHz to 26 GHz, lowest channel, vertical & horizontal polarization

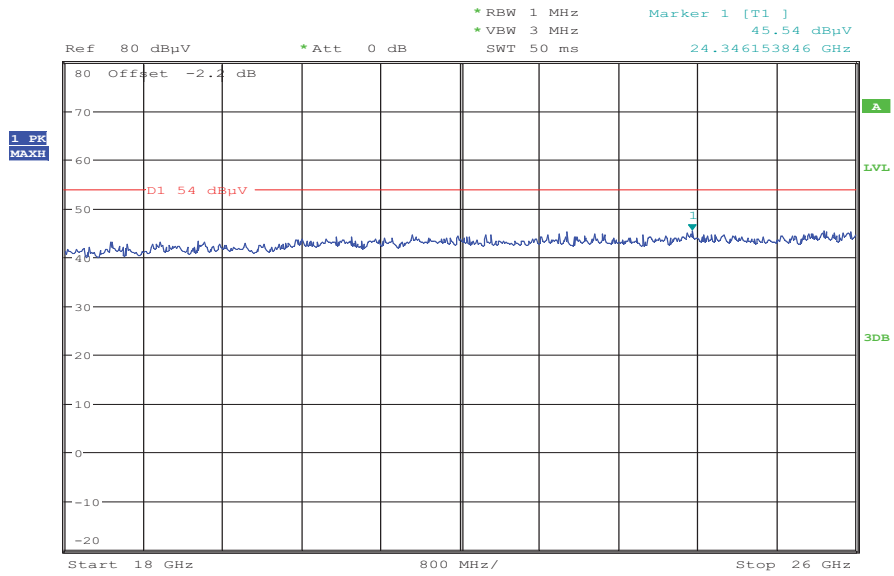

Date: 18.JAN.2013 12:36:55

Plot 5: 30 MHz to 1 GHz, mid channel, vertical & horizontal polarization

Common Information

EUT: TM-0000-BV
 Serial Number: CB5A1MD99N
 Test Description: FCC part 15 class B @ 10m
 Operating Conditions: TX BT LE Ch. 19 + charging
 Operator Name: Hennemann
 Comment: AC: 115 V / 60 Hz

Scan Setup: STAN_Fin [EMI radiated]

Hardware Setup: Electric Field (NOS)
 Receiver: [ESCI 3]
 Level Unit: dBµV/m

Subrange	Step Size	Detectors	IF BW	Meas. Time	Preamp
30 MHz - 2 GHz	60 kHz	QPK	120 kHz	1 s	20 dB
		FCC_10m(B)_3			

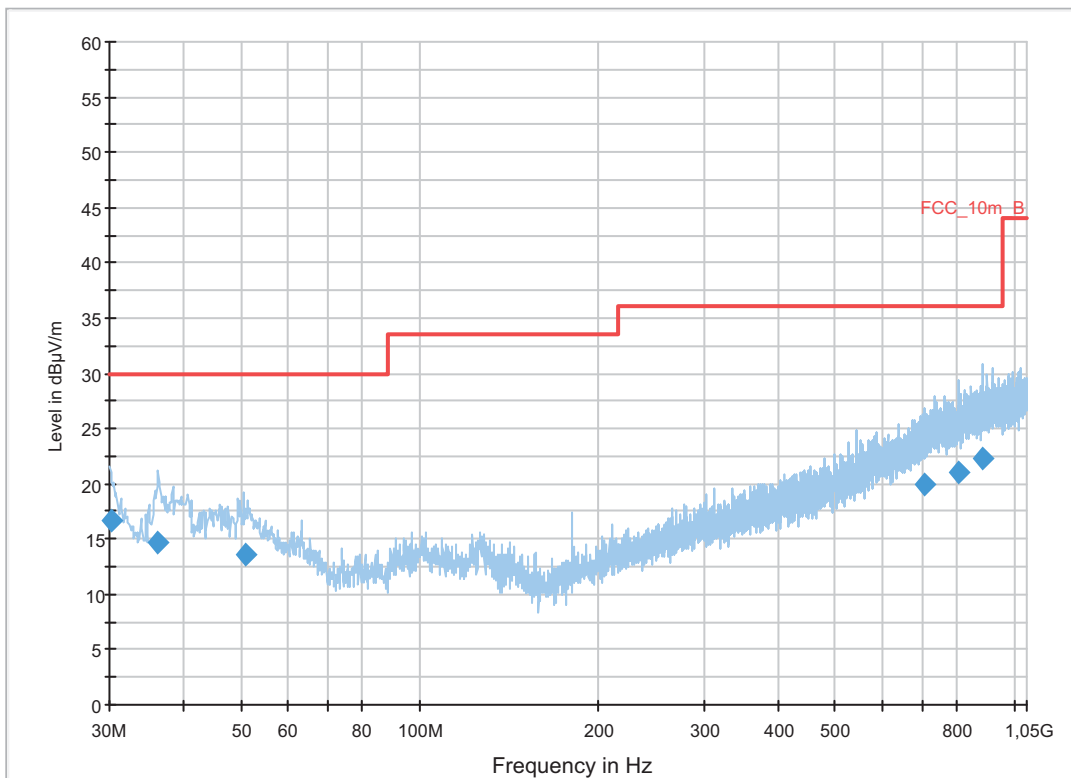

Final Result 1

Frequency (MHz)	QuasiPeak (dBµV/m)	Meas. Time (ms)	Bandwidth (kHz)	Height (cm)	Polarization	Azimuth (deg)	Corr. (dB)	Margin (dB)	Limit (dBµV/m)	Comment
30.267600	16.6	1000.0	120.000	153.0	V	-10.0	12.5	13.4	30.0	
36.221700	14.7	1000.0	120.000	152.0	V	88.0	13.1	15.3	30.0	
50.944350	13.6	1000.0	120.000	98.0	V	268.0	13.3	16.4	30.0	
705.227550	19.9	1000.0	120.000	170.0	V	180.0	22.6	16.1	36.0	
808.748850	21.0	1000.0	120.000	132.0	V	10.0	23.9	15.0	36.0	
884.665800	22.2	1000.0	120.000	170.0	V	89.0	25.0	13.8	36.0	

Plot 6: 1 GHz to 12.75 GHz, mid channel, vertical & horizontal polarization

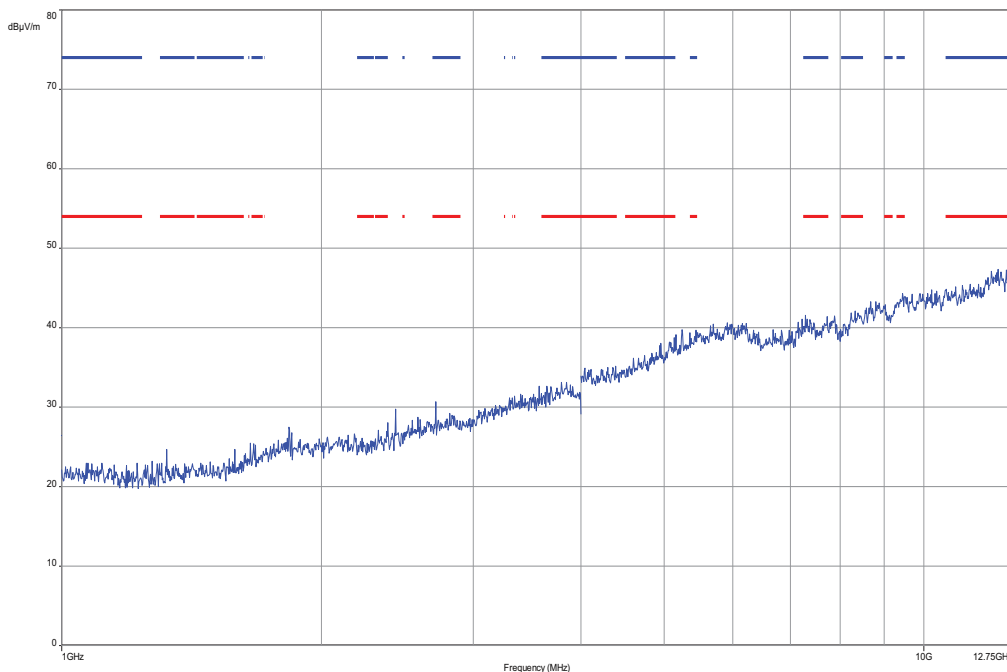

Carrier suppressed with a 2.4 GHz-band rejection filter.

Plot 7: 12 GHz to 18 GHz, mid channel, vertical & horizontal polarization

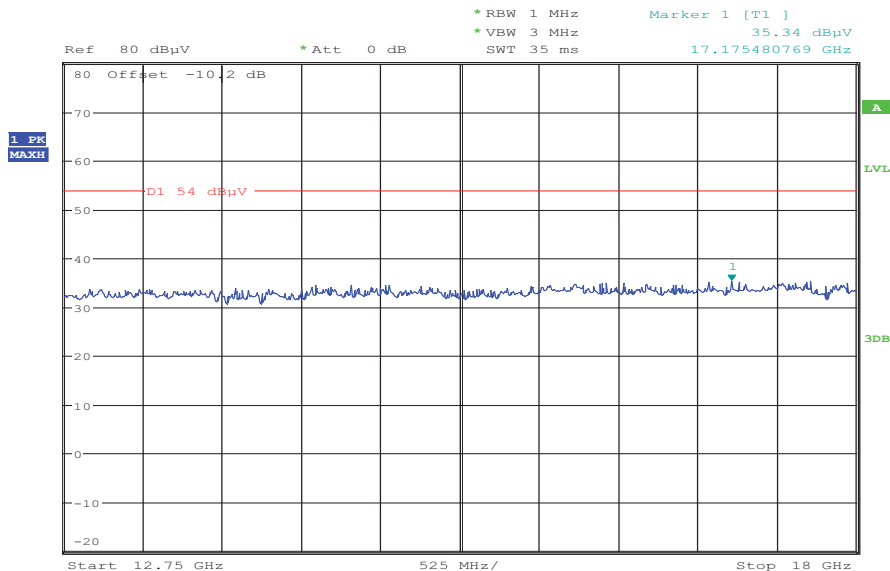

Date: 18.JAN.2013 12:34:26

Plot 8: 18 GHz to 26 GHz, mid channel, vertical & horizontal polarization

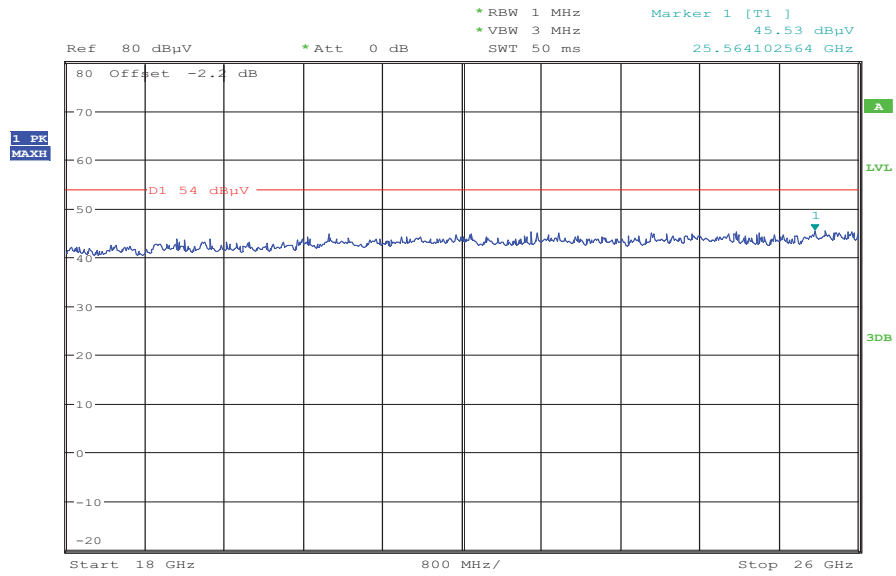

Date: 18.JAN.2013 12:37:29

Plot 9: 30 MHz to 1 GHz, highest channel, vertical & horizontal polarization

Common Information

EUT: TM-0000-BV
 Serial Number: CB5A1MD99N
 Test Description: FCC part 15 class B @ 10m
 Operating Conditions: TX BT LE Ch. 39 + charging
 Operator Name: Hennemann
 Comment: AC: 115 V / 60 Hz

Scan Setup: STAN_Fin [EMI radiated]

Hardware Setup: Electric Field (NOS)
 Receiver: [ESCI 3]
 Level Unit: dBµV/m

Subrange	Step Size	Detectors	IF BW	Meas. Time	Preamp
30 MHz - 2 GHz	60 kHz	QPK	120 kHz	1 s	20 dB
		FCC_10m(B)_3			

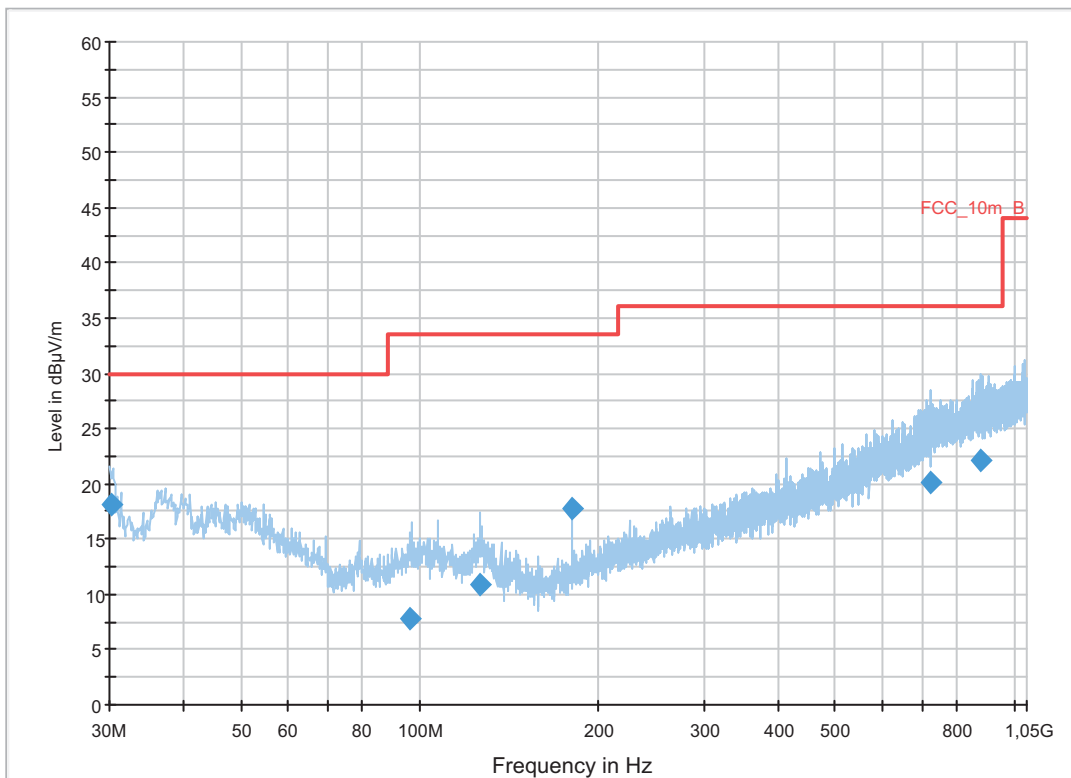

Final Result 1

Frequency (MHz)	QuasiPeak (dBµV/m)	Meas. Time (ms)	Bandwidth (kHz)	Height (cm)	Polarization	Azimuth (deg)	Corr. (dB)	Margin (dB)	Limit (dBµV/m)	Comment
30.151425	18.2	1000.0	120.000	144.0	V	280.0	12.5	11.8	30.0	
96.458550	7.9	1000.0	120.000	170.0	H	2.0	11.4	25.6	33.5	
126.038850	11.0	1000.0	120.000	98.0	V	100.0	9.7	22.5	33.5	
180.012300	17.7	1000.0	120.000	170.0	V	2.0	10.4	15.8	33.5	
721.202100	20.2	1000.0	120.000	170.0	V	10.0	23.0	15.8	36.0	
880.133550	22.2	1000.0	120.000	170.0	V	190.0	24.9	13.8	36.0	

Plot 10: 1 GHz to 12.75 GHz, highest channel, vertical & horizontal polarization

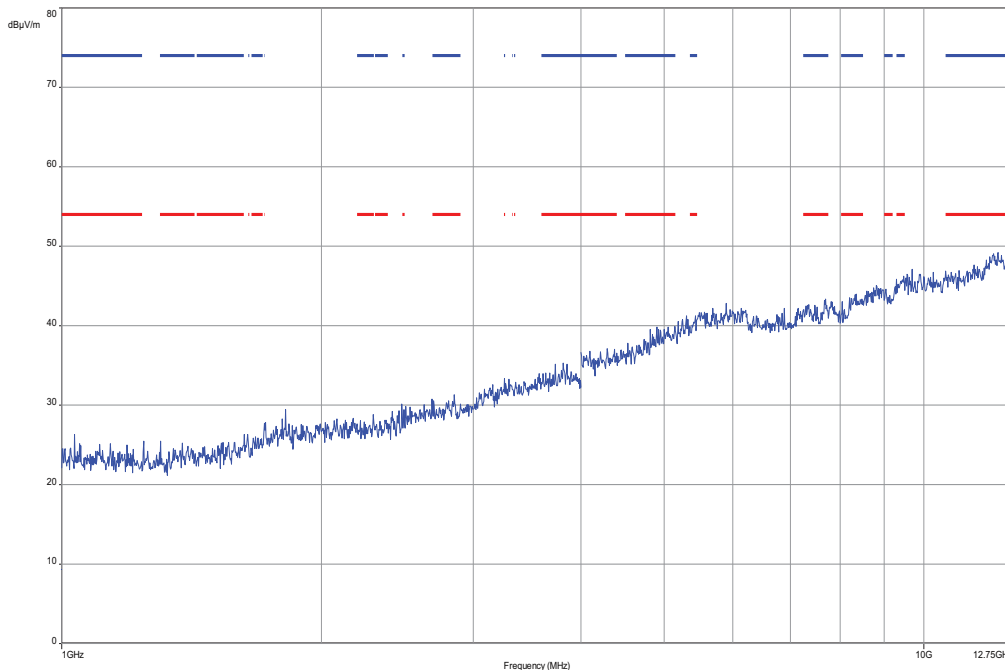

Carrier suppressed with a 2.4 GHz-band rejection filter.

Plot 11: 12 GHz to 18 GHz, highest channel, vertical & horizontal polarization

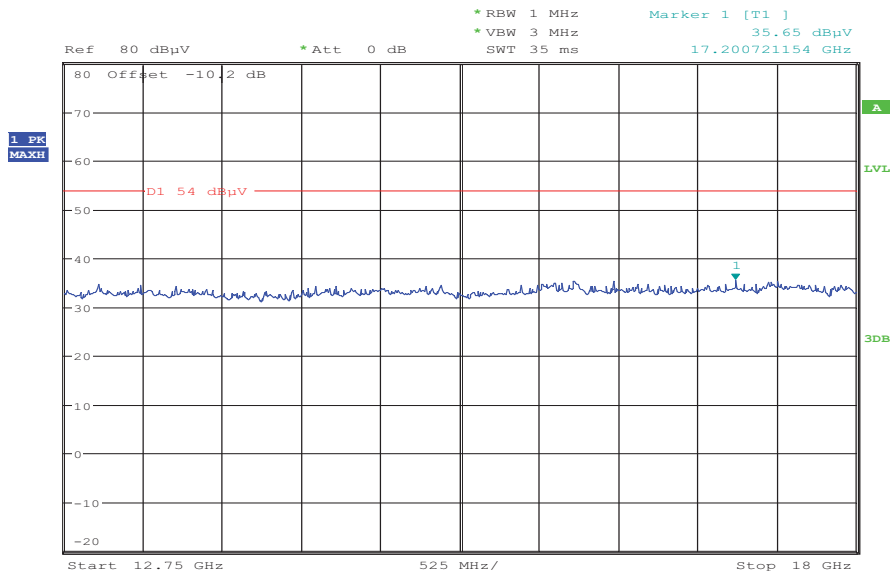

Date: 18.JAN.2013 12:35:13

Plot 12: 18 GHz to 26 GHz, highest channel, vertical & horizontal polarization

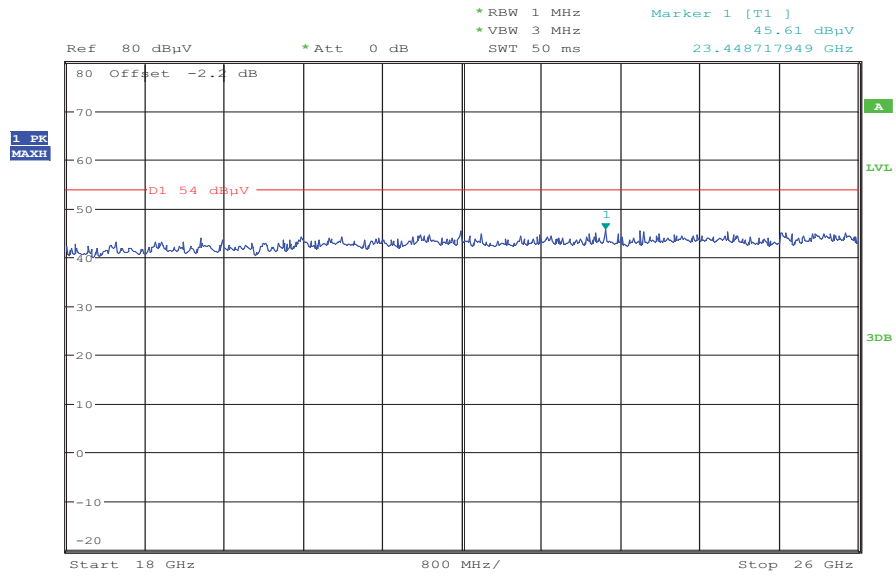

Date: 18.JAN.2013 12:37:56

9.13 RX spurious emissions radiated

Description:

Measurement of the radiated spurious emissions in idle/receive mode. The EUT is detached so all oscillators are active.

Measurement:

Measurement parameter	
Detector:	Peak / Quasi peak
Sweep time:	Auto
Resolution bandwidth:	F < 1 GHz: 100 kHz F > 1 GHz: 1 MHz
Video bandwidth:	Sweep: 100 kHz Remeasurement: 10 Hz
Span:	30 MHz to 26 GHz
Trace-Mode:	Max Hold

Limits:

FCC		IC
RX Spurious Emissions Radiated		
Frequency (MHz)	Field strength (dBµV/m)	Measurement distance
30 - 88	30.0	10
88 – 216	33.5	10
216 – 960	36.0	10
Above 960	54.0	3

Results:

RX spurious emissions radiated [dBµV/m]		
F [MHz]	Detector	Level [dBµV/m]
For emissions below 1 GHz, please take a look at the table below the 1 GHz plot.		
Measurement uncertainty	±3 dB	

Result: Passed

Plots:

Plot 1: 30 MHz to 1 GHz, RX / idle – mode, vertical & horizontal polarization

Common Information

EUT: TM-0000-BV
 Serial Number: CB5A1MD99N
 Test Description: FCC part 15 class B @ 10m
 Operating Conditions: RX BT + charging
 Operator Name: Hennemann
 Comment: AC: 115 V / 60 Hz

Scan Setup: STAN_Fin [EMI radiated]

Hardware Setup: Electric Field (NOS)
 Receiver: [ESCI 3]
 Level Unit: dBµV/m

Subrange	Step Size	Detectors	IF BW	Meas. Time	Preamp
30 MHz - 2 GHz	60 kHz	QPK	120 kHz	1 s	20 dB

FCC_10m(B)_3

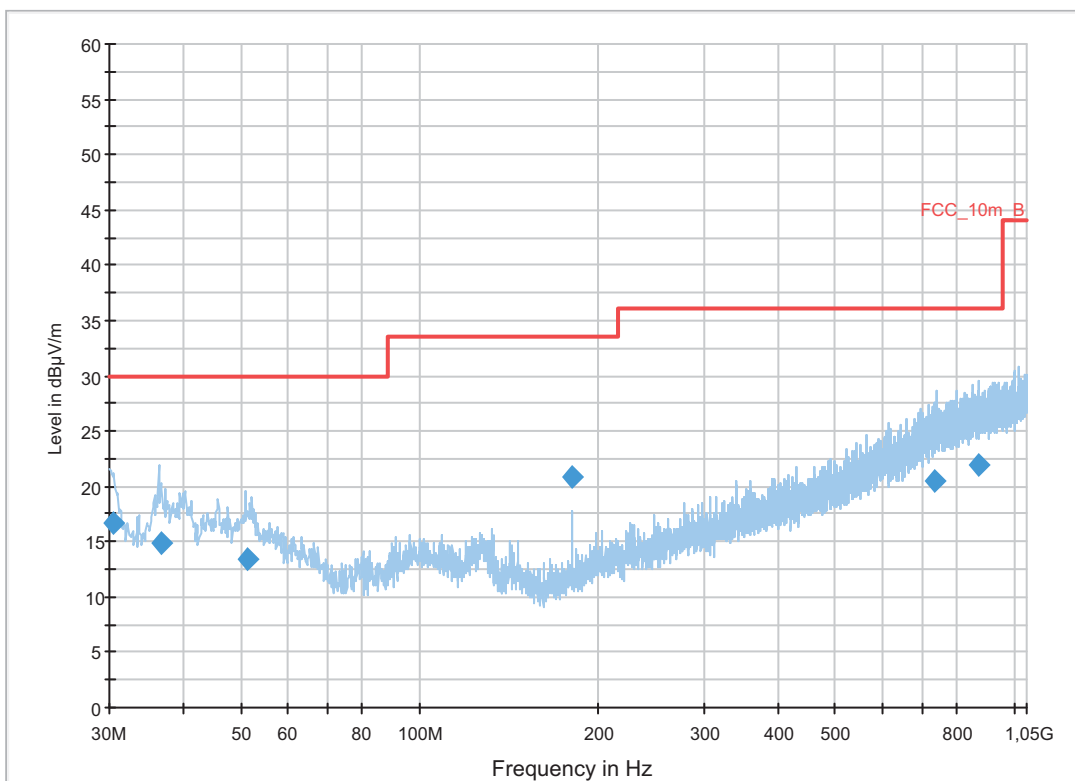

Final Result 1

Frequency (MHz)	QuasiPeak (dBµV/m)	Meas. Time (ms)	Bandwidth (kHz)	Height (cm)	Polarization	Azimuth (deg)	Corr. (dB)	Margin (dB)	Limit (dBµV/m)	Comment
30.511875	16.7	1000.0	120.000	143.0	V	261.0	12.6	13.3	30.0	
36.637050	14.9	1000.0	120.000	111.0	V	100.0	13.2	15.1	30.0	
51.232350	13.4	1000.0	120.000	111.0	V	10.0	13.2	16.6	30.0	
179.984550	20.8	1000.0	120.000	130.0	V	190.0	10.4	12.7	33.5	
732.259650	20.4	1000.0	120.000	152.0	V	100.0	23.3	15.6	36.0	
868.882500	22.0	1000.0	120.000	170.0	H	175.0	24.8	14.0	36.0	

Plot 2: 1 GHz to 12.75 GHz, RX / idle – mode, vertical & horizontal polarization

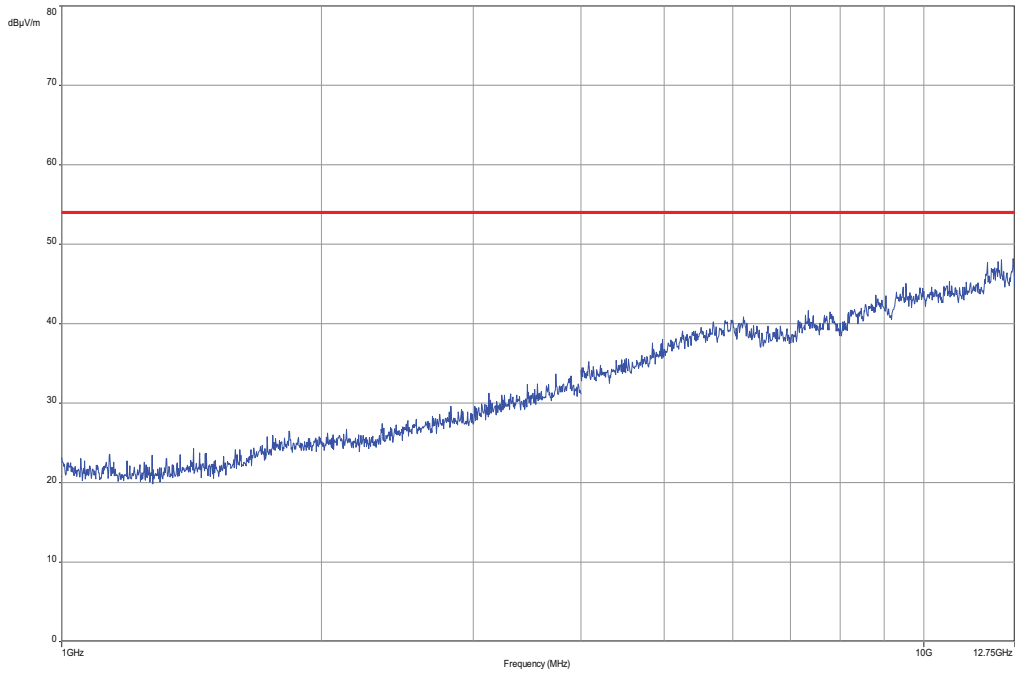

Plot 3: 12 GHz to 18 GHz, RX / idle – mode, vertical & horizontal polarization

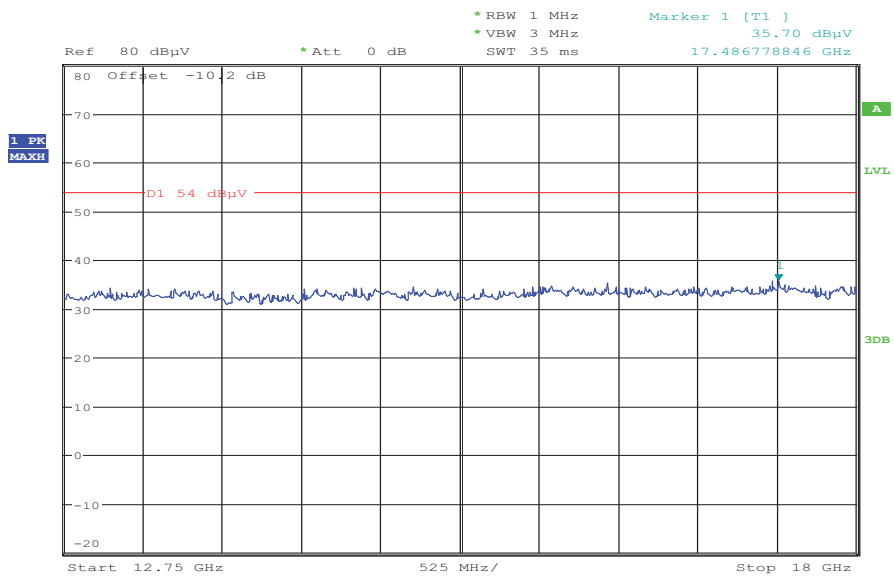

Date: 18.JAN.2013 12:35:51

Plot 4: 18 GHz to 26 GHz, RX / idle – mode, vertical & horizontal polarization

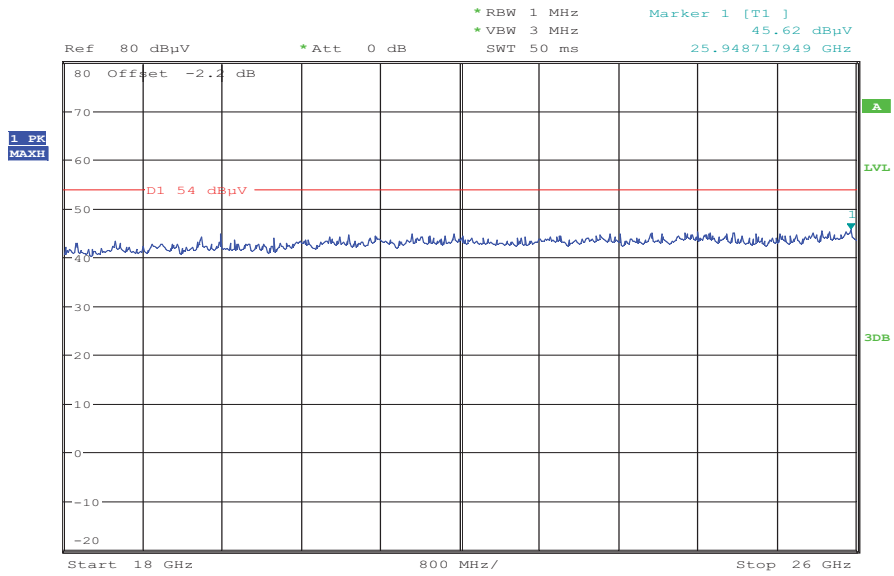

Date: 18.JAN.2013 12:38:32

9.14 Spurious emissions radiated < 30 MHz

Description:

Measurement of the radiated spurious emissions in transmit mode below 30 MHz. The EUT is set to single channel mode and the transmit channel is channel 19. This measurement is representative for all channels and modes. If critical peaks are found channel 00 and channel 39 will be measured too. The measurement is performed in the mode with the highest output power. The limits are recalculated to a measurement distance of 3 m with 40 dB/decade according CFR Part 2.

Measurement:

Measurement parameter	
Detector:	Peak / Quasi peak
Sweep time:	Auto
Resolution bandwidth:	F < 150 kHz: 1 kHz F > 150 kHz: 100 kHz
Video bandwidth:	F < 150 kHz: 200 Hz F > 150 kHz: 9 kHz
Span:	9 kHz to 30 MHz
Trace-Mode:	Max Hold

Limits:

FCC		IC
TX spurious emissions radiated < 30 MHz		
Frequency (MHz)	Field strength (dB μ V/m)	Measurement distance
0.009 – 0.490	2400/F(kHz)	300
0.490 – 1.705	24000/F(kHz)	30
1.705 – 30.0	30	30

Results:

TX spurious emissions radiated < 30 MHz [dB μ V/m]		
F [MHz]	Detector	Level [dB μ V/m]
No critical peaks found!		
Measurement uncertainty	± 3 dB	

Result: Passed

Plot:

Plot 1: 9 kHz to 30 MHz, TX mode

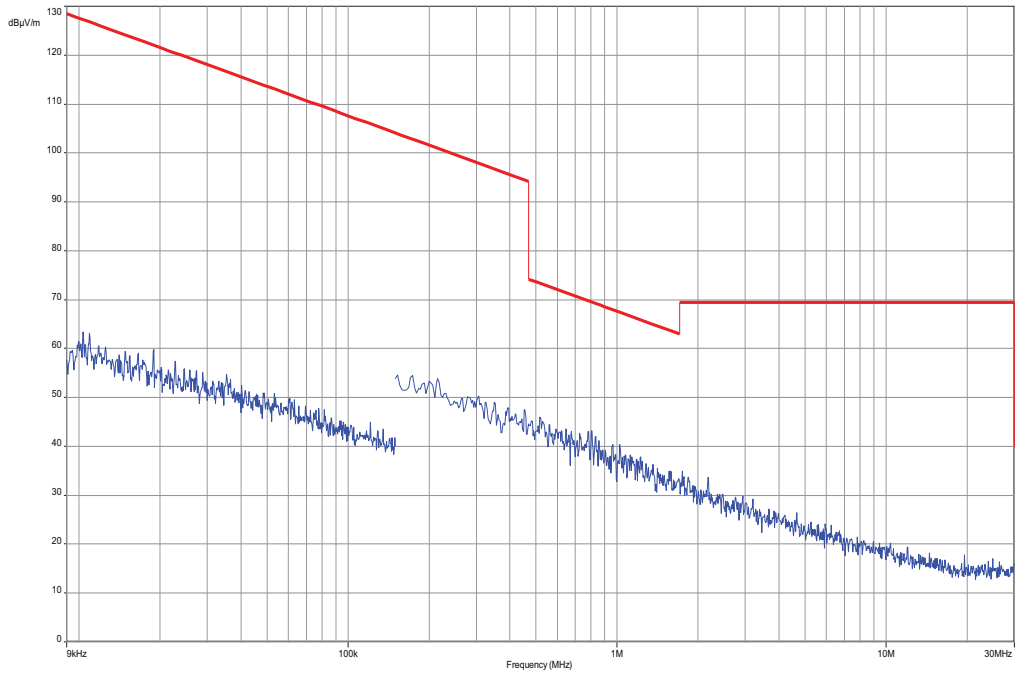

Plot 2: 9 kHz to 30 MHz, RX mode

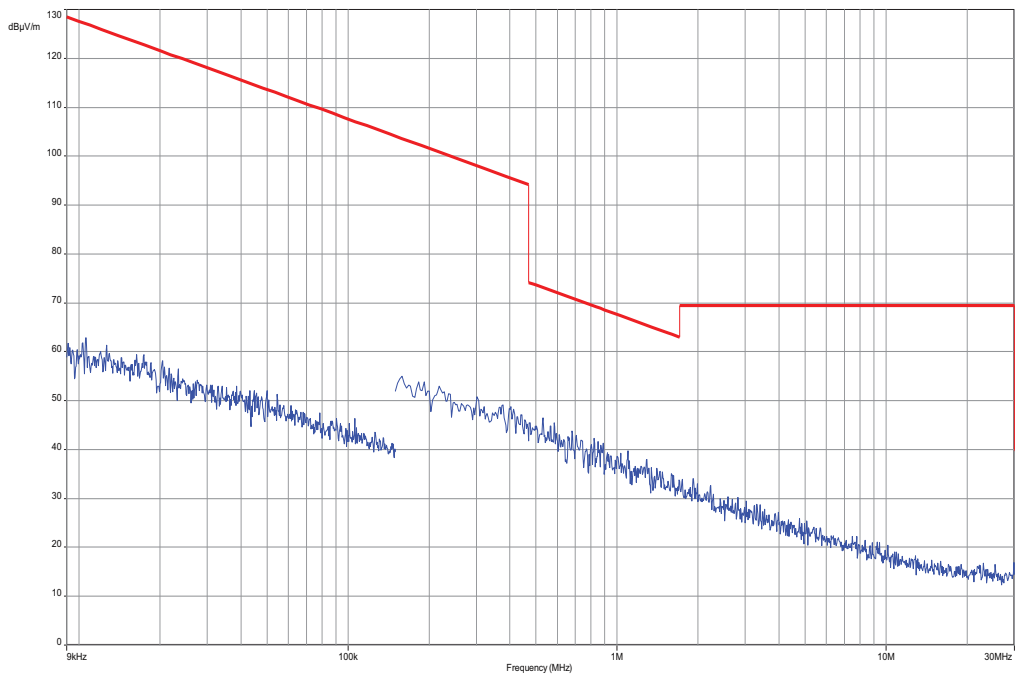

9.15 Spurious emissions conducted < 30 MHz

Description:

Measurement of the conducted spurious emissions in transmit mode below 30 MHz. The EUT is set to single channel mode and the transmit channel is channel 19. This measurement is representative for all channels and modes. If critical peaks are found channel 00 and channel 39 will be measured too. The measurement is performed in the mode with the highest output power. Both power lines, phase and neutral line, are measured. Found peaks are remeasured with average and quasi peak detection to show compliance to the limits.

Measurement:

Measurement parameter	
Detector:	Peak / Quasi peak / average
Sweep time:	Auto
Resolution bandwidth:	F > 150 kHz: 100 kHz
Video bandwidth:	F > 150 kHz: 9 kHz
Span:	150 kHz to 30 MHz
Trace-Mode:	Max Hold

Limits:

FCC	IC	
TX spurious emissions conducted < 30 MHz		
Frequency (MHz)	Quasi-peak (dB μ V/m)	Average (dB μ V/m)
0.15 – 0.5	66 to 56*	56 to 46*
0.5 – 5	56	46
5 – 30.0	60	50

*Decreases with the logarithm of the frequency

Results:

TX spurious emissions conducted < 30 MHz [dB μ V/m]		
F [MHz]	Detector	Level [dB μ V/m]
No critical peaks found!		
Measurement uncertainty	± 3 dB	

Result: Passed

Plots:

Plot 1: 150 kHz to 30 MHz, TX mode, phase line

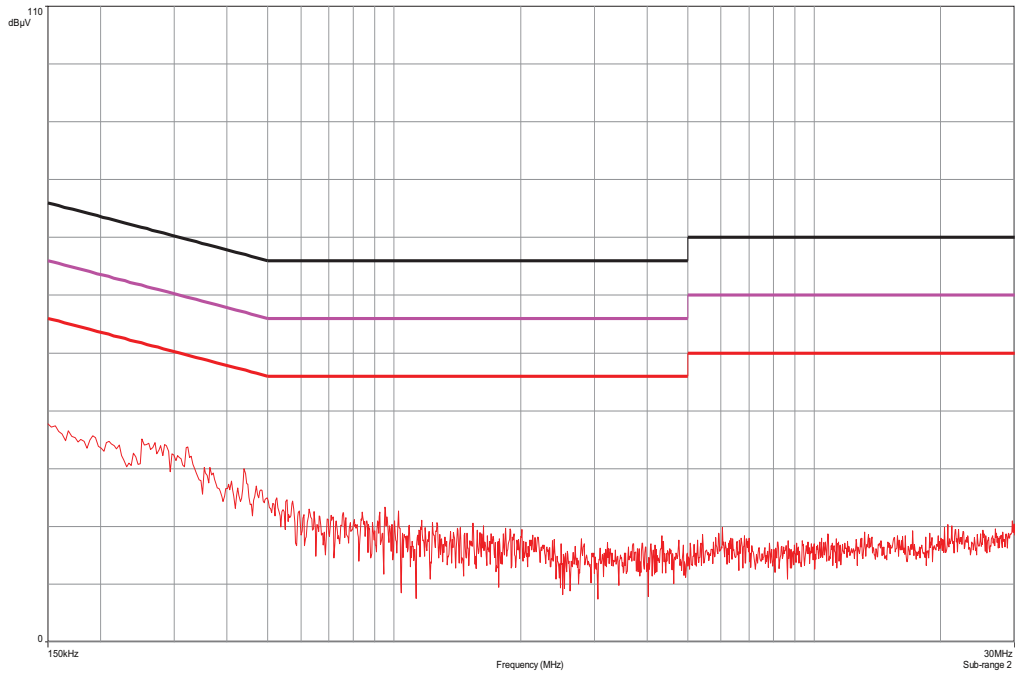

Plot 2: 150 kHz to 30 MHz, TX mode, neutral line

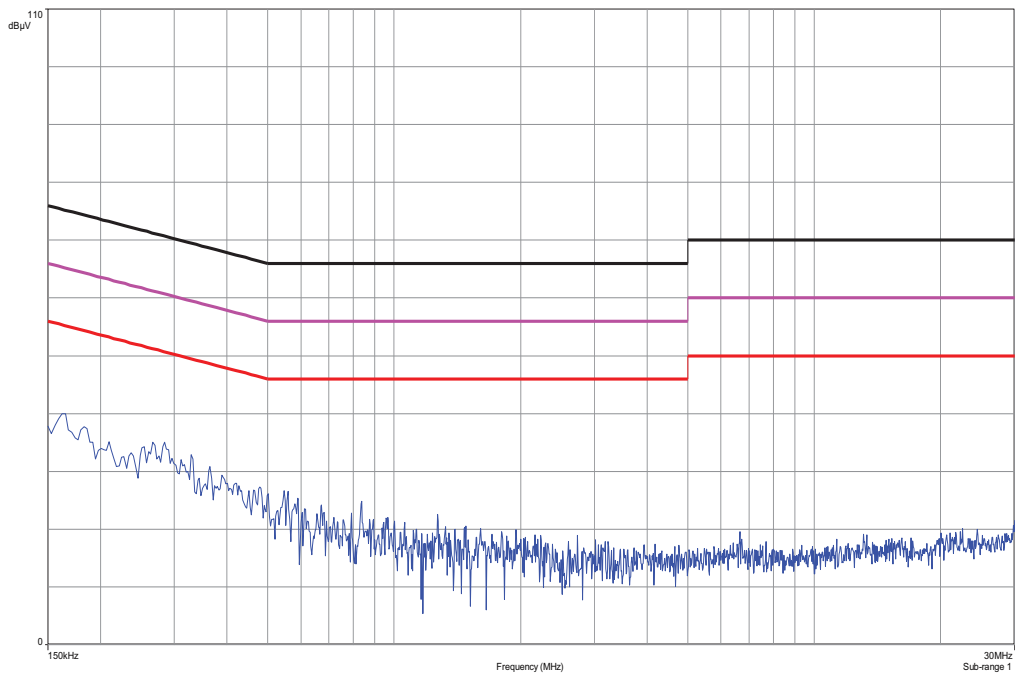

Plot 3: 150 kHz to 30 MHz, RX mode, phase line

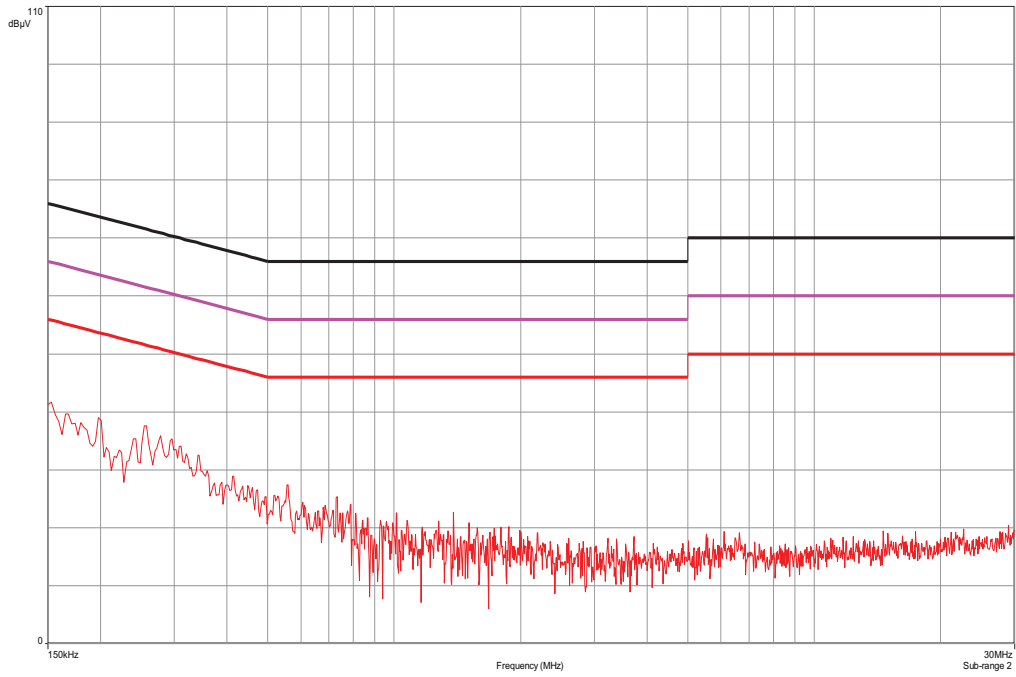

Plot 4: 150 kHz to 30 MHz, RX mode, neutral line

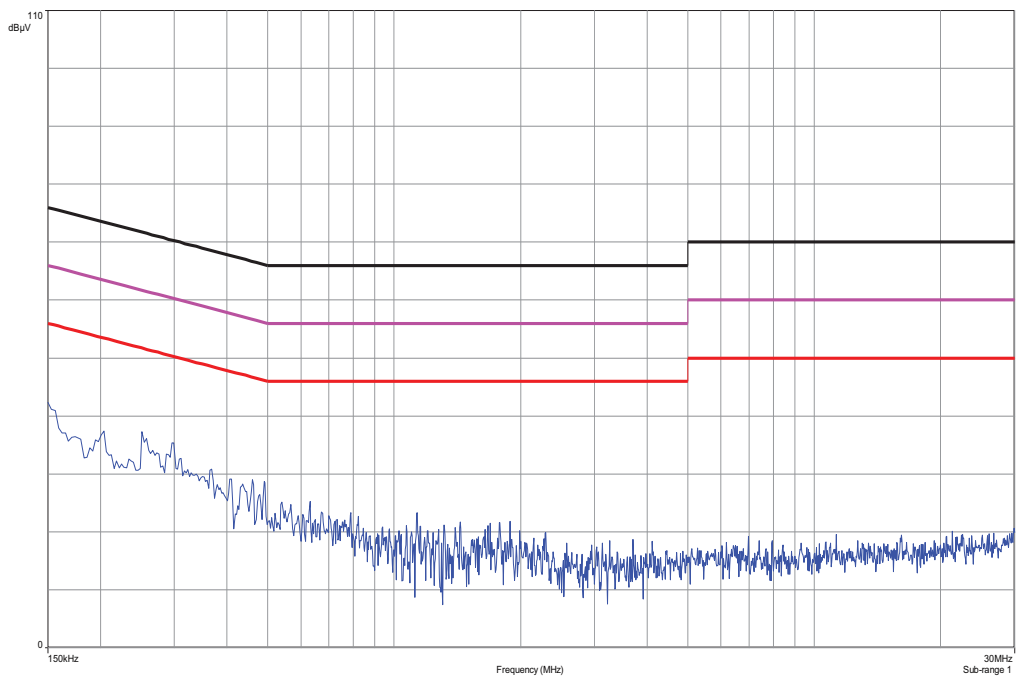

10 Test equipment and ancillaries used for tests

Typically, the calibrations of the test apparatus are commissioned to and performed by an accredited calibration laboratory. The calibration intervals are determined in accordance with the DIN EN ISO/IEC 17025. In addition to the external calibrations, the laboratory executes comparison measurements with other calibrated test systems or effective verifications. Weekly chamber inspections and range calibrations are performed. Where possible, rf-generating and signalling equipment as well as measuring receivers and analyzers are connected to an external high-precision 10 MHz reference (GPS-based or rubidium frequency standard).

In order to simplify the identification of the equipment used at some special tests, some items of test equipment and ancillaries can be provided with an identifier or number in the equipment list below (Labor/Item).

No.	Lab / Item	Equipment	Type	Manufact.	Serial No.	INV. No Cetecom	Kind of Calibration	Last Calibration	Next Calibration
1	45	Switch-Unit	3488A	HP Meßtechnik	2719A14505	300000368	g		
2	50	DC power supply, 60Vdc, 50A, 1200 W	6032A	HP Meßtechnik	2920A04466	300000580	ne		
3	n. a.	software	SPS_PHE 1.4f	Spitzberger & Spieß	B5981; 5D1081;B597 9	300000210	ne		
4	n. a.	EMI Test Receiver	ESCI 1166.5950. 03	R&S	100083	300003312	k		
5	n. a.	Analyzer- Reference- System (Harmonics and Flicker)	ARS 16/1	SPS	A3509 07/0 0205	300003314	k	14.07.2011	14.07.2013
6	n. a.	Amplifier	JS42- 00502650- 28-5A	MITEQ	1084532	300003379	ev		
7	n. a.	Antenna Tower	Model 2175	ETS- LINDGREN	64762	300003745	izw		
8	n. a.	Positioning Controller	Model 2090	ETS- LINDGREN	64672	300003746	izw		
9	n. a.	Turntable Interface-Box	Model 105637	ETS- LINDGREN	44583	300003747	izw		
10	n. a.	TRILOG Broadband Test-Antenna 30 MHz - 3 GHz	VULB9163	Schwarzbe ck	295	300003787	k	12.04.2012	12.04.2014
11	n. a.	Spectrum- Analyzer	FSU26	R&S	200809	300003874	k	06.01.2012	06.01.2014
12	n. a.	Double-Ridged Waveguide Horn Antenna 1-18.0GHz	3115	EMCO	8812-3088	300001032	vIKI!	11.05.2011	11.05.2013
13	n. a.	Active Loop Antenna	6502	EMCO	2210	300001015	ne		
14	n. a.	Anechoic chamber	FAC 3/5m	MWB / TDK	87400/02	300000996	ev		
15	n. a.	Switch / Control Unit	3488A	HP Meßtechnik	*	300000199	ne		
16	n. a.	Switch / Control Unit	3488A	HP Meßtechnik	2719A15013	300001156	ne		
17	9	Isolating Transformer	MPL IEC625 Bus Regeltrennt ravo	Erfi	91350	300001155	ne		
18	n. a.	Three-Way Power Splitter, 50 Ohm	11850C	HP Meßtechnik		300000997	ne		
19	n. a.	Amplifier	js42- 00502650- 28-5a	Parzich GMBH	928979	300003143	ne		
20	n. a.	Band Reject filter	WRCG240 0/2483- 2375/2505- 50/10SS	Wainwright	11	300003351	ev		
21	n. a.	TRILOG Broadband Test-Antenna 30 MHz - 3 GHz	VULB9163	Schwarzbe ck	371	300003854	vIKI!	14.10.2011	14.10.2014
22	n. a.	MXE EMI	N9038A	Agilent	MY51210197	300004405	k		

		Receiver 20 Hz bis 26,5 GHz		Technologies					
23	11b	Microwave System Amplifier, 0.5-26.5 GHz	83017A	HP Meßtechnik	00419	300002268	ev		
24	A026	Std. Gain Horn Antenna 12.4 to 18.0 GHz	639	Narda		300000787	ne		
25	A029	Std. Gain Horn Antenna 18.0 to 26.5 GHz	638	Narda		300002442	ne		
26	n. a.	Spectrum Analyzer 20 Hz - 50 GHz	FSU50	R&S	200012	300003443	Ve	09.10.2012	09.10.2014
27	n. a.	Switch / Control Unit	3488A	HP Meßtechnik		300001691	ne		
28	n. a.	Power Supply DC	NGPE 40/40	R&S	388	400000078	vKl!	21.08.2012	21.08.2014
29	n. a.	Power Sensor 50 Ohms, 10 MHz - 18 GHz, 1 nW - 20 mW	NRV-Z1	R&S	833894/011	300002681-0010	k	22.08.2012	22.08.2014
30	n. a.	Hygro-Thermometer	-/, 5-45°C, 20-100%rF	Thies Clima	-/	400000080	k	24.09.2012	24.09.2013
31	n. a.	Switch / Control Unit	SSCU	R&S	338864/003	300002681-0006	ne		
32	n. a.	Frequency Standard (Rubidium Frequency Standard)	MFS (Rubidium)	R&S (Datum)	002	300002681-0009	Ve	21.08.2012	21.08.2014
33	n. a.	Directional Coupler	101020010	Krytar	70215	300002840	ev		
34	n. a.	DC-Blocker	8143	Inmet Corp.	none	300002842	ne		
35	n. a.	Powersplitter	6005-3	Inmet Corp.		300002841	ev		
36	n. a.	Spectrum Analyzer 9kHz to 30GHz - 140..+30dBm	FSP30	R&S	100886	300003575	k	22.08.2012	22.08.2014

Agenda: Kind of Calibration

k calibration / calibrated
 ne not required (k, ev, izw, zw not required)
 ev periodic self verification
 Ve long-term stability recognized
 vKl! Attention: extended calibration interval
 NK! Attention: not calibrated

EK limited calibration
 zw cyclical maintenance (external cyclical maintenance)
 izw internal cyclical maintenance
 g blocked for accredited testing
 *) next calibration ordered / currently in progress

11 Observations

No observations exceeding those reported with the single test cases have been made.

Annex A Photographs of the test setup

Photo documentation:

Photo 1:



Photo 2:



Photo 3:

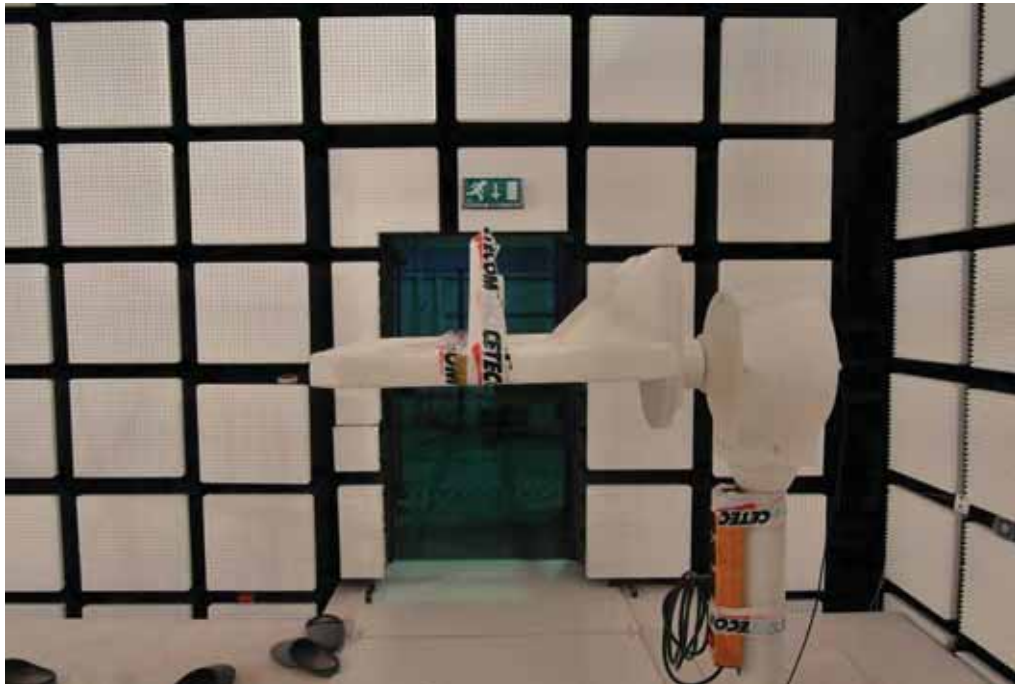

Photo 4:



Photo 5:



Photo 6:



Annex B External photographs of the EUT

Photo documentation:

Photo 1:

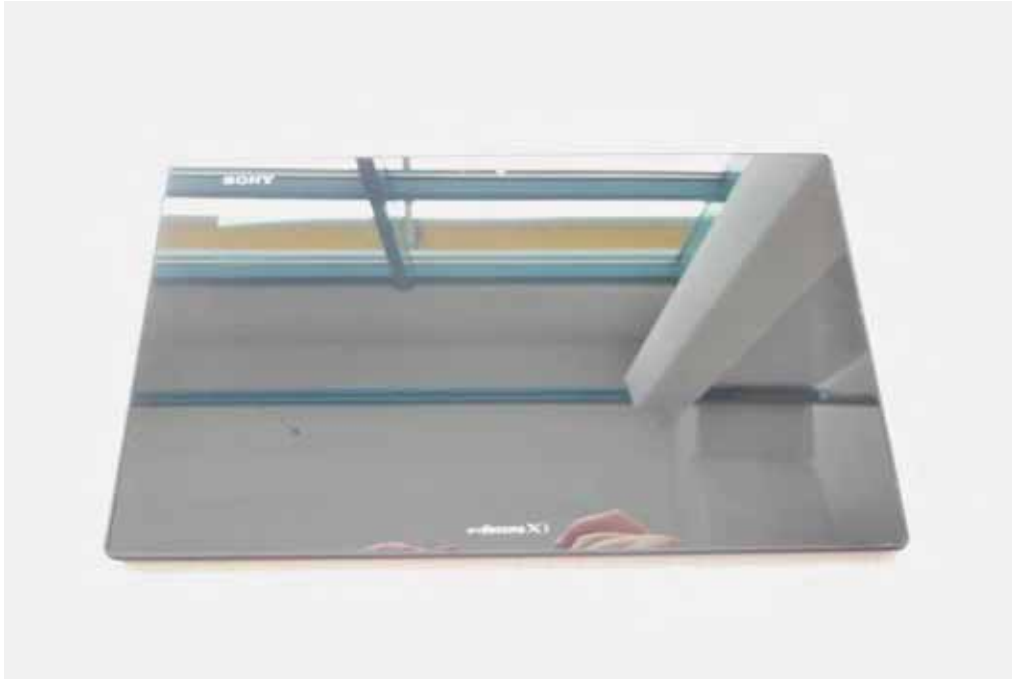

Photo 2:



Photo 3:



Photo 4:



Photo 5:



Photo 6:



Photo 7:

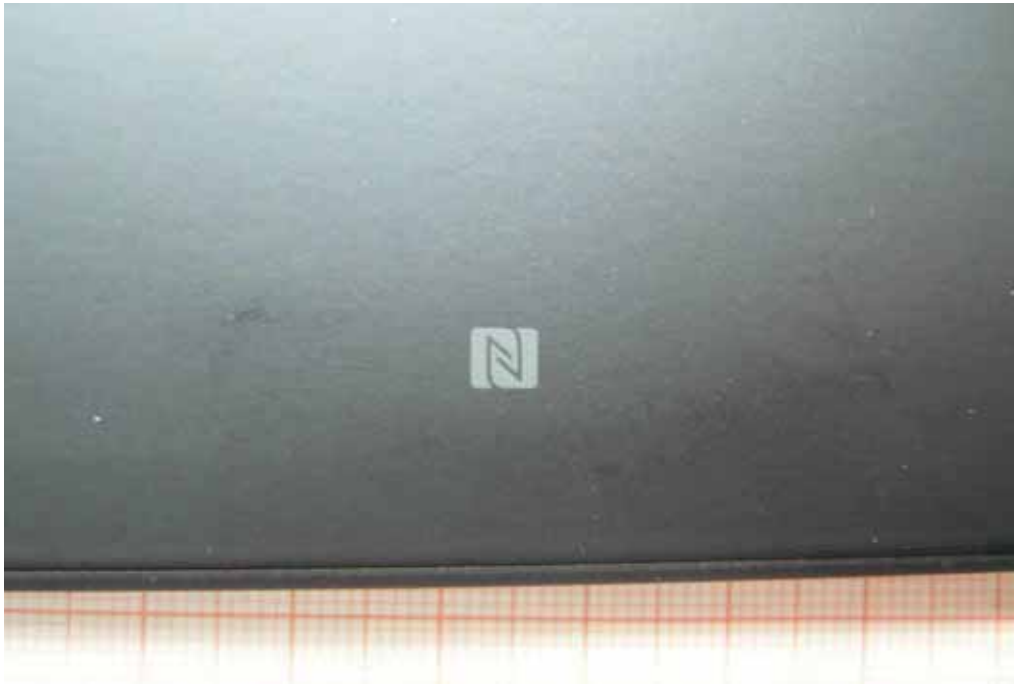

Photo 8:



Photo 9:



Photo 10:



Photo 11:



Photo 12:



Photo 13:



Photo 14:



Photo 15:



Annex C Internal photographs of the EUT

Photo documentation:

Photo 1:

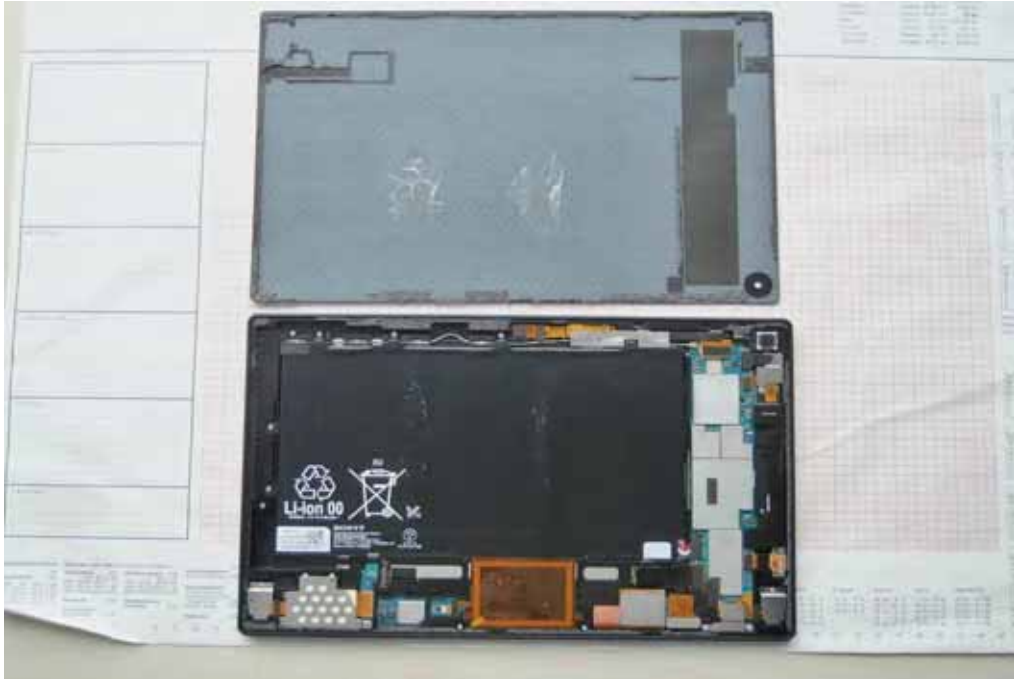

Photo 2:



Photo 3:



Photo 4:



Photo 5:



Photo 6:

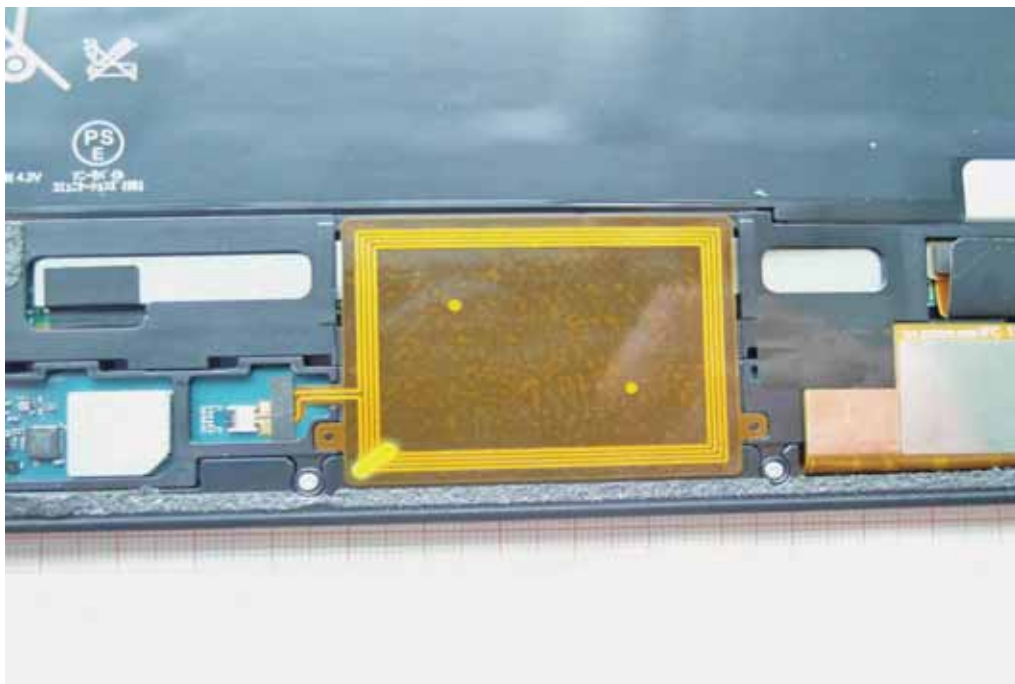

Photo 7:

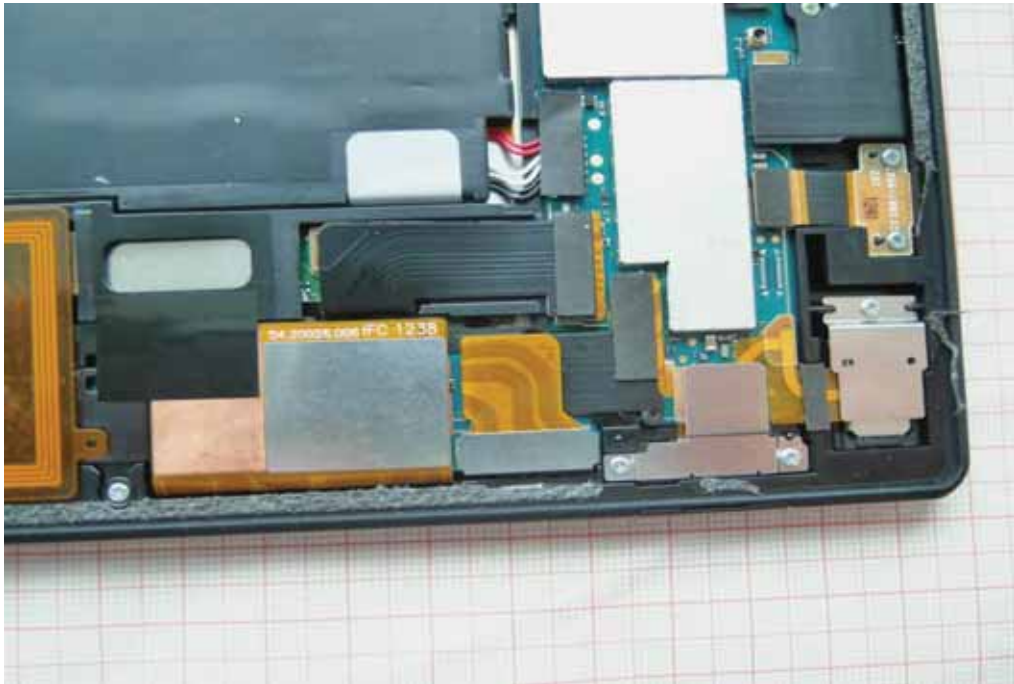

Photo 8:



Photo 9:



Photo 10:



Photo 11:



Photo 12:

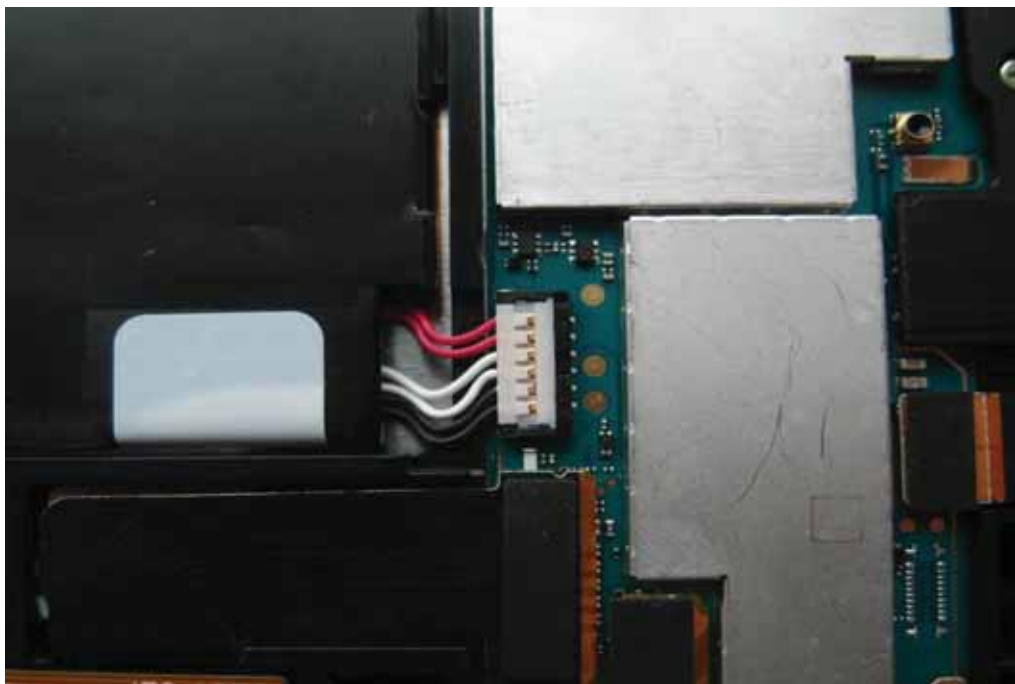

Photo 13:

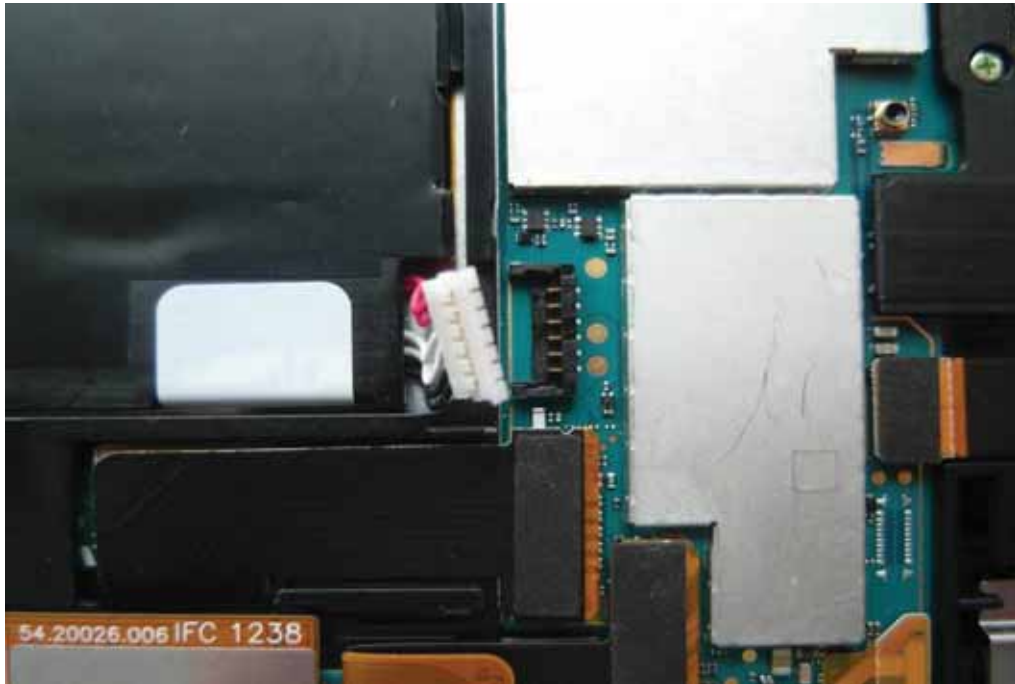

Photo 14:

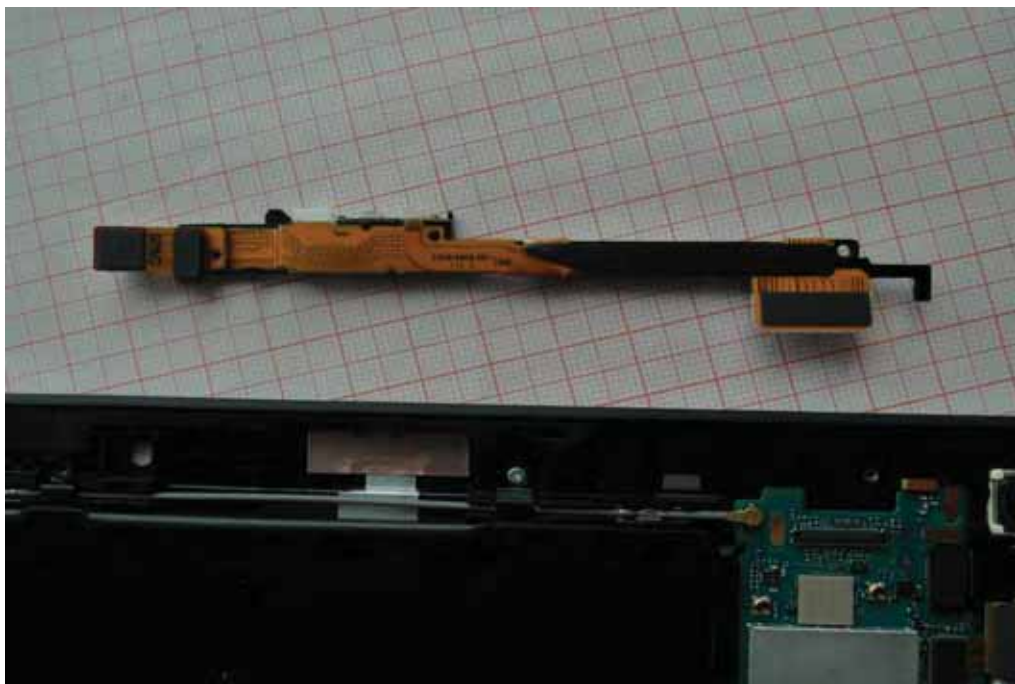

Photo 15:



Photo 16:



Photo 17:

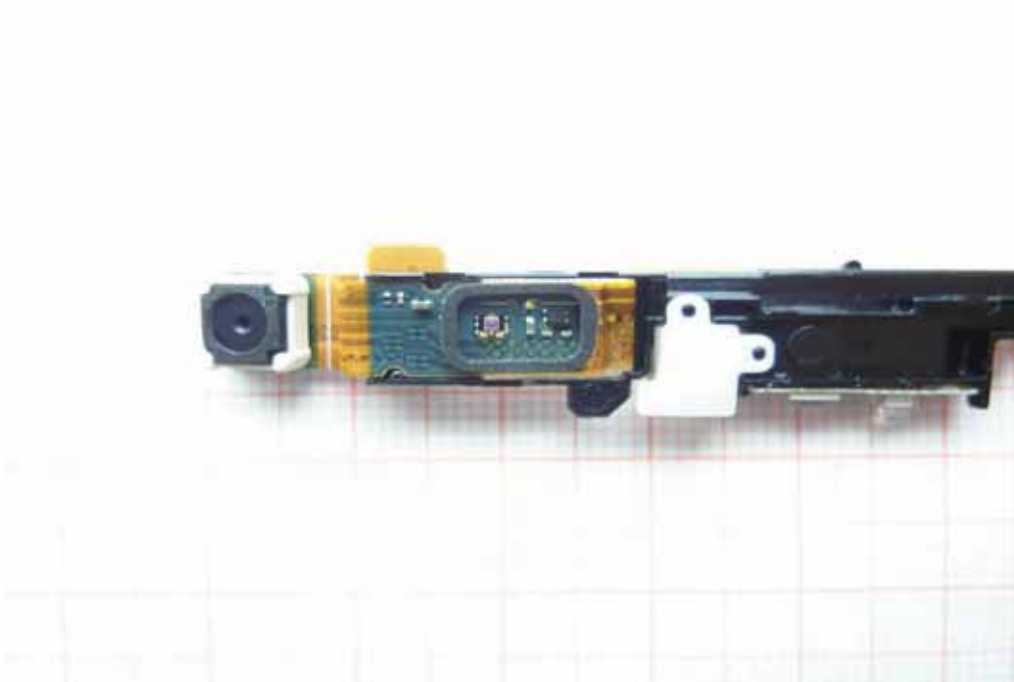

Photo 18:



Photo 19:



Photo 20:

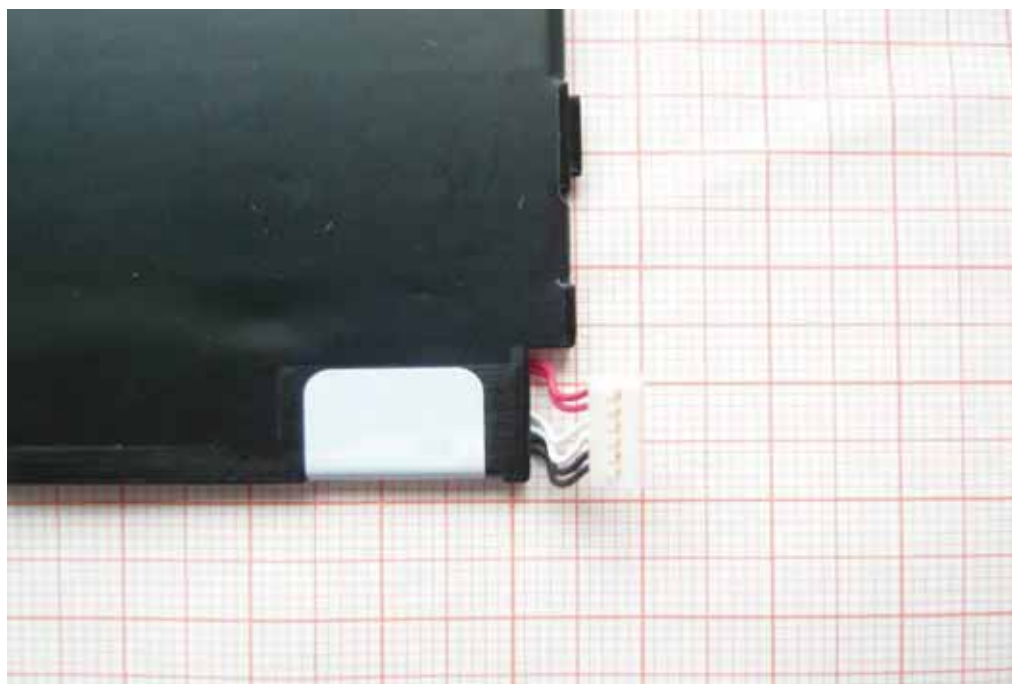

Photo 21:

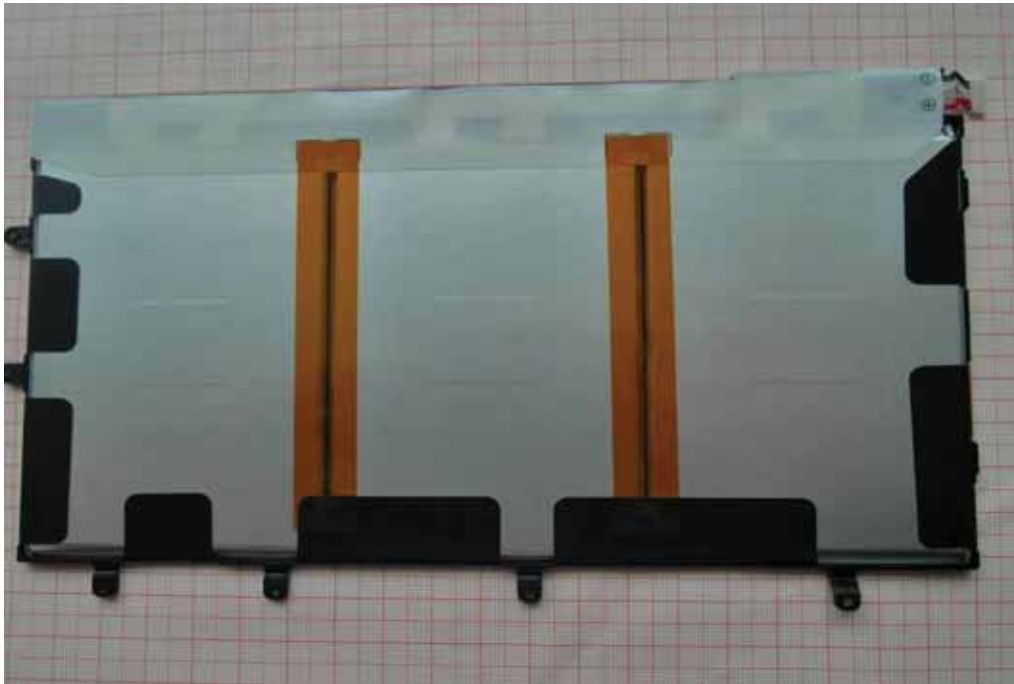

Photo 22:

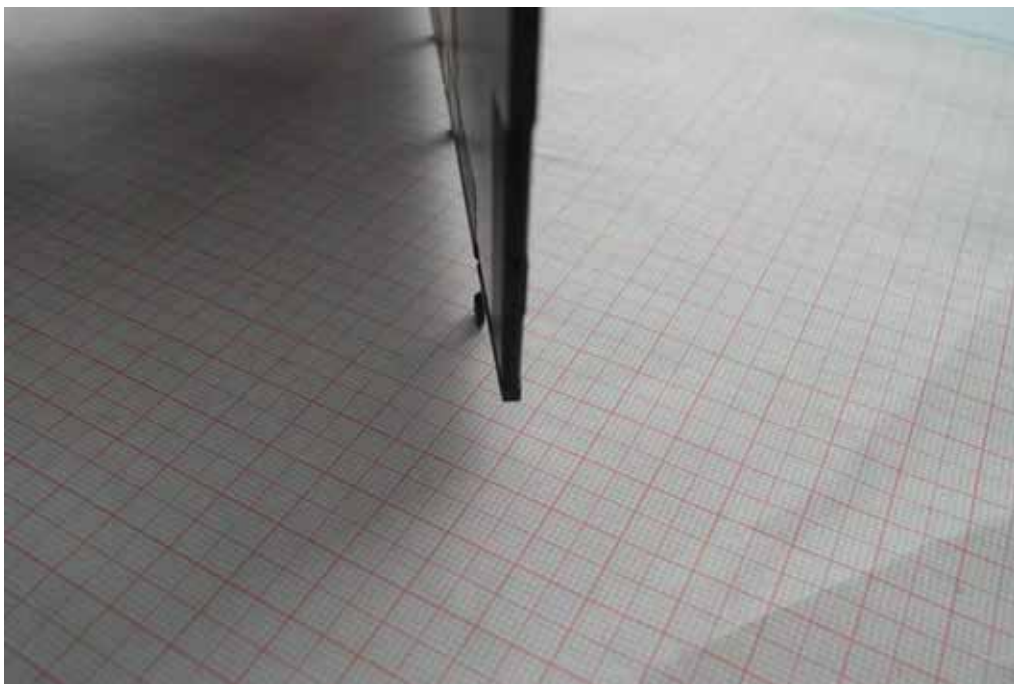

Photo 23:



Photo 24:



Photo 25:



Photo 26:



Photo 27:

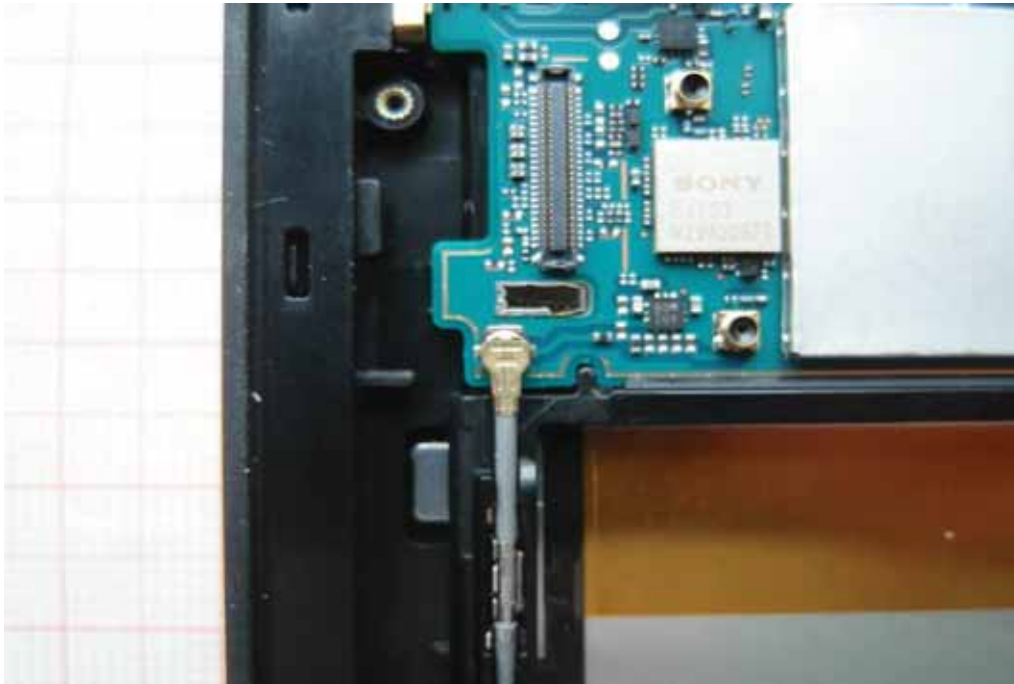

Photo 28:



Photo 29:



Photo 30:



Photo 31:

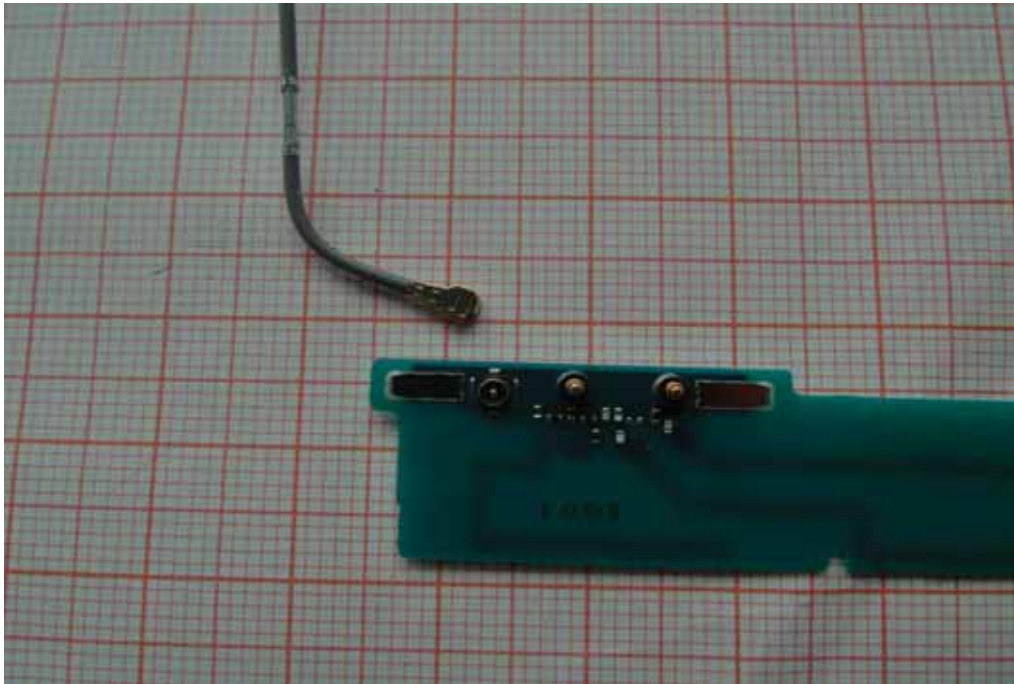

Photo 32:

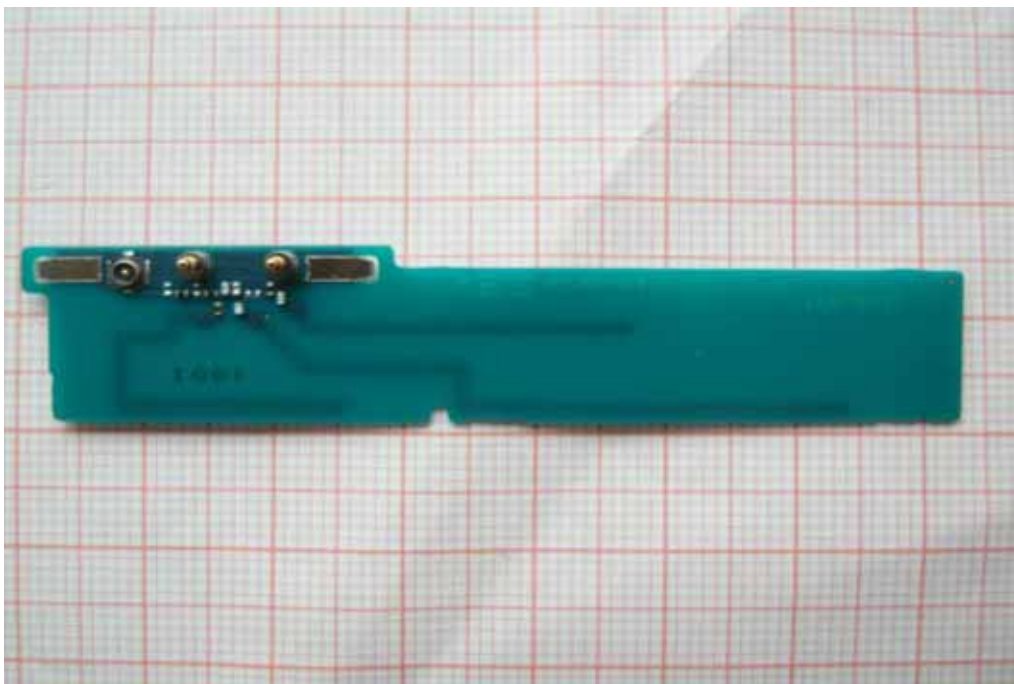

Photo 33:

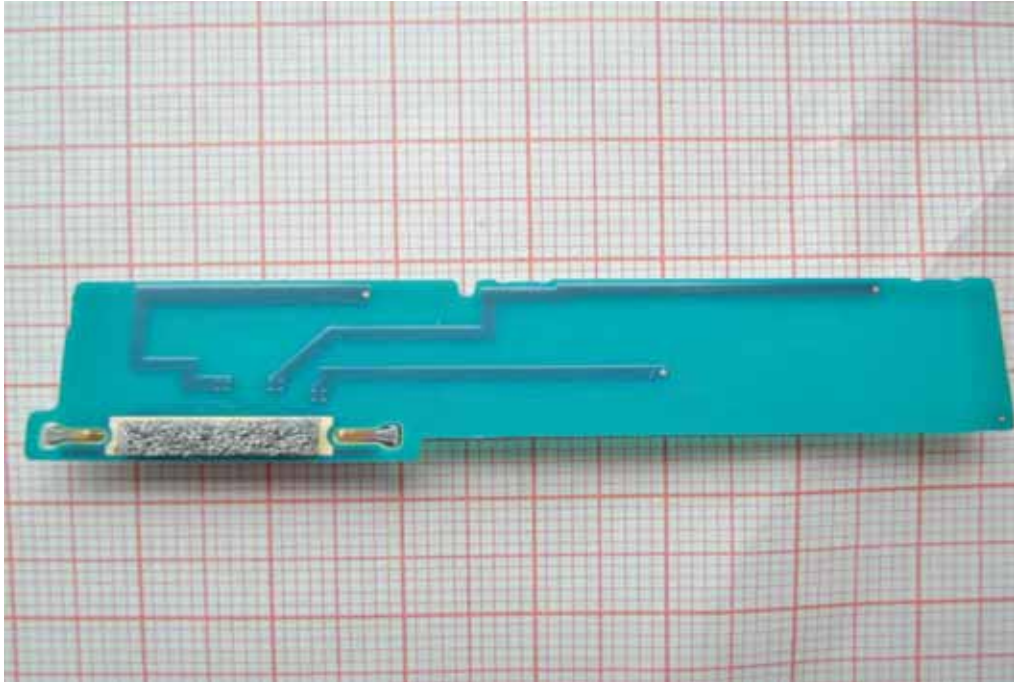

Photo 34:

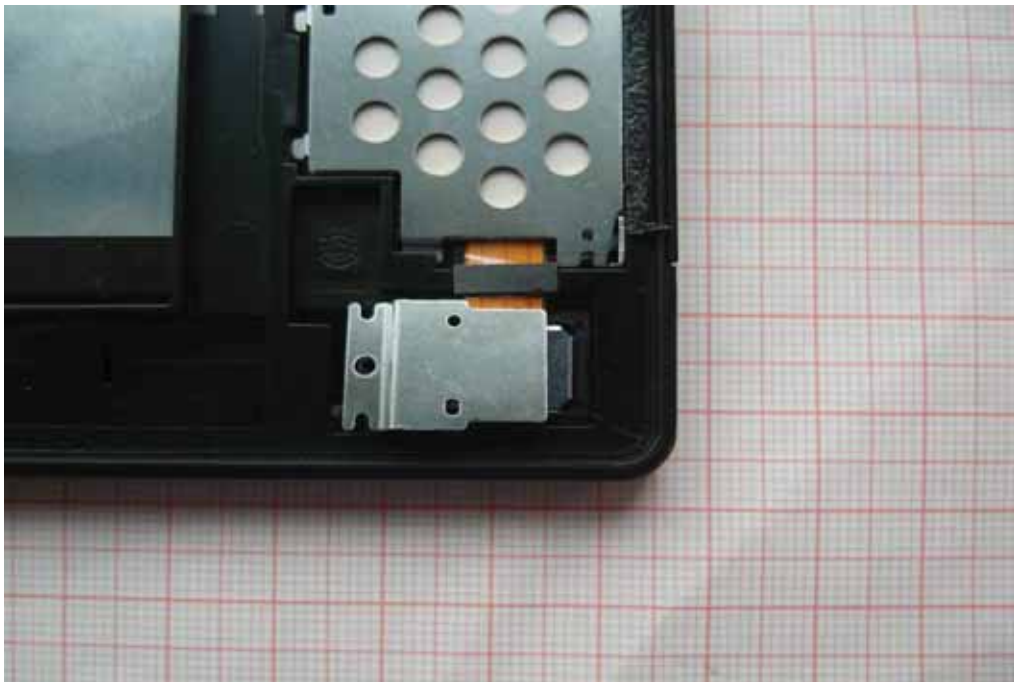

Photo 35:

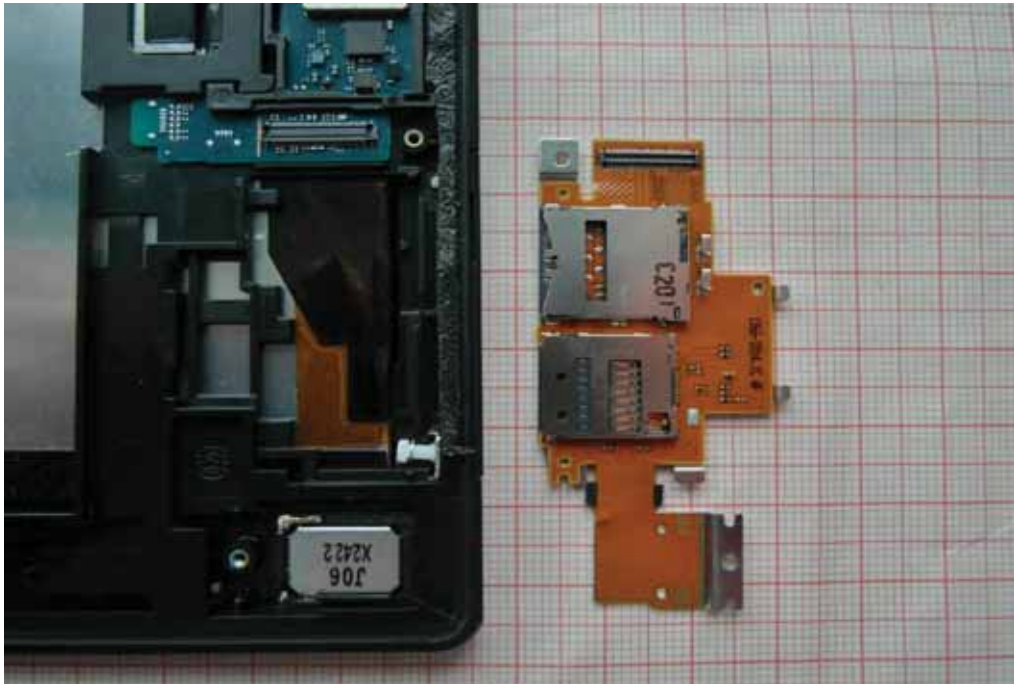

Photo 36:



Photo 37:



Photo 38:

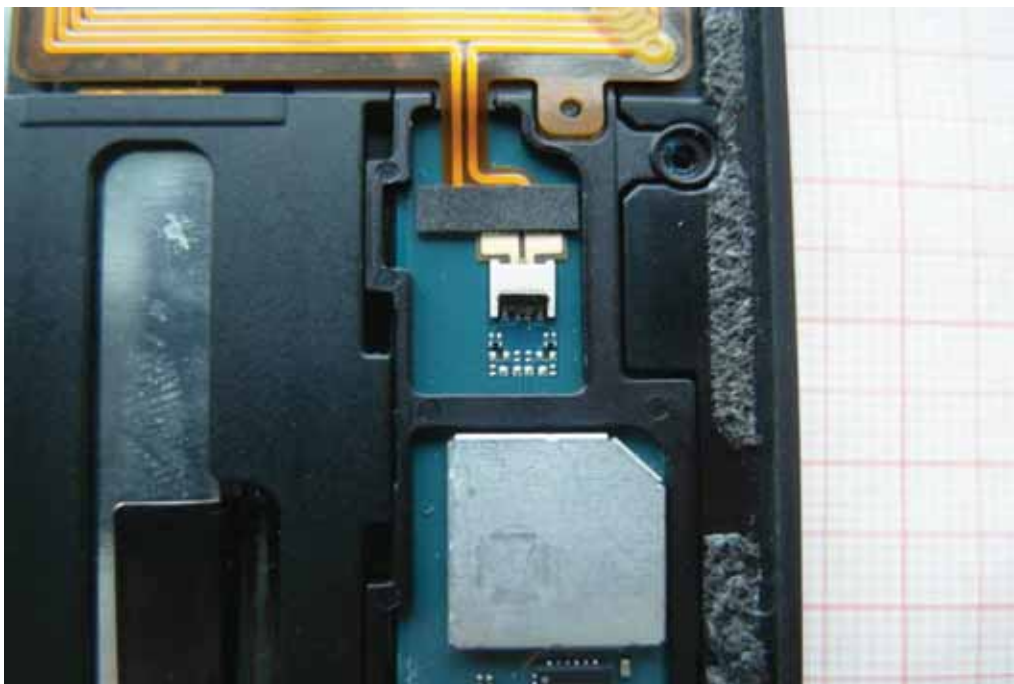

Photo 39:

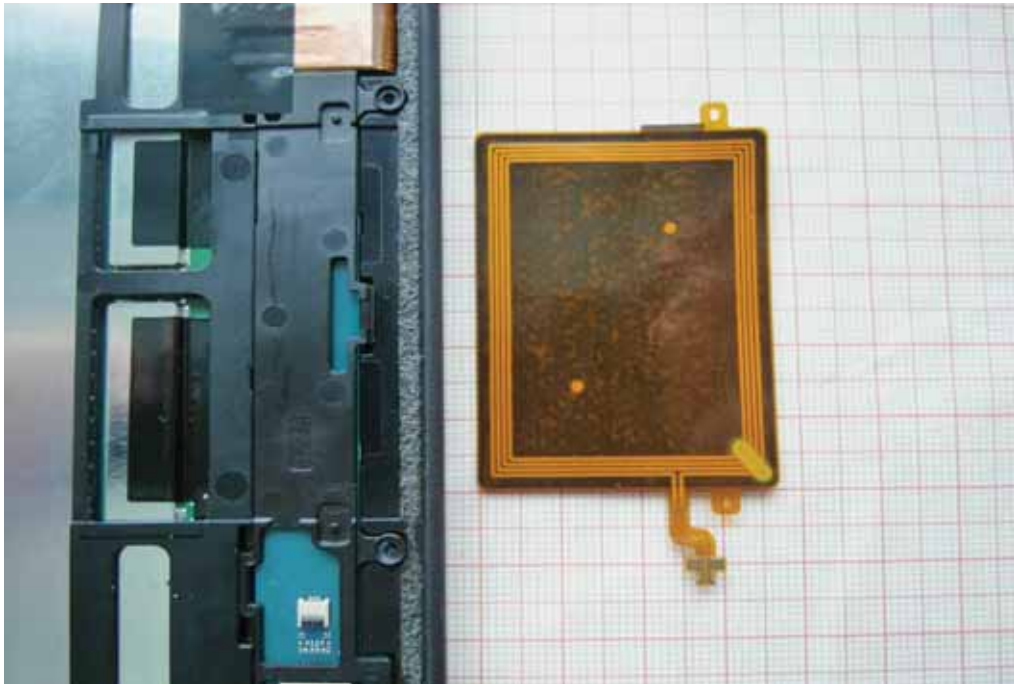

Photo 40:

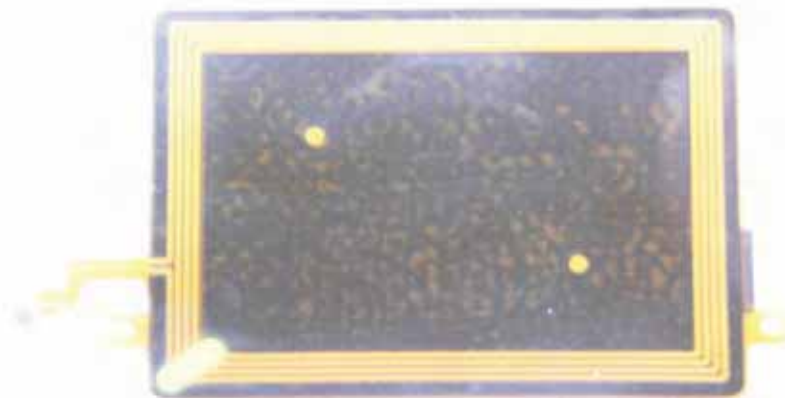

Photo 41:



Photo 42:

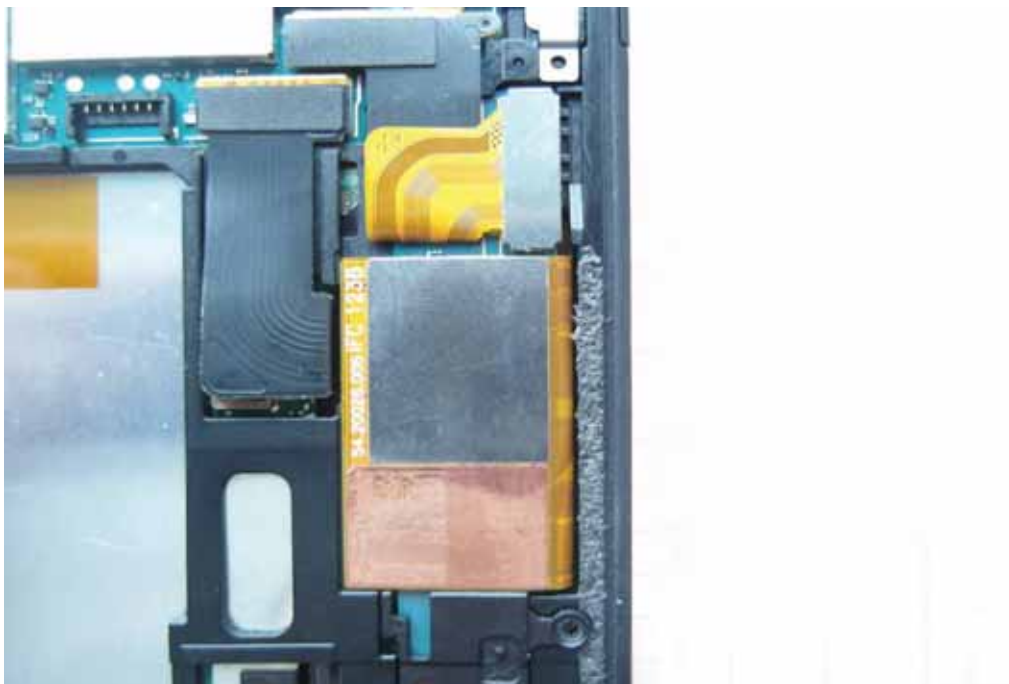

Photo 43:

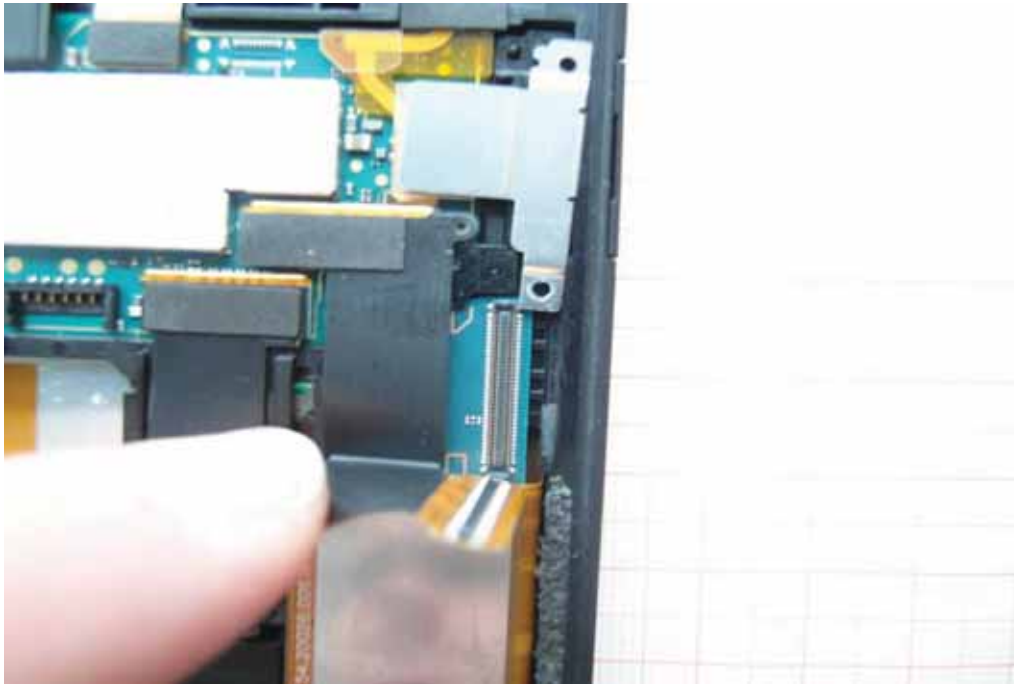

Photo 44:

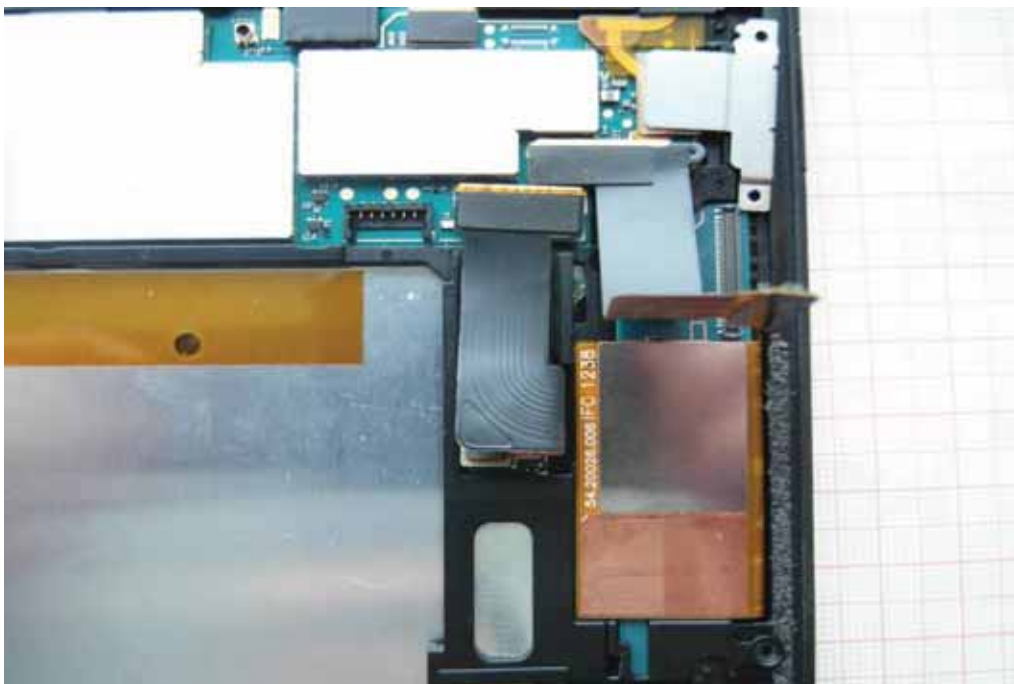

Photo 45:

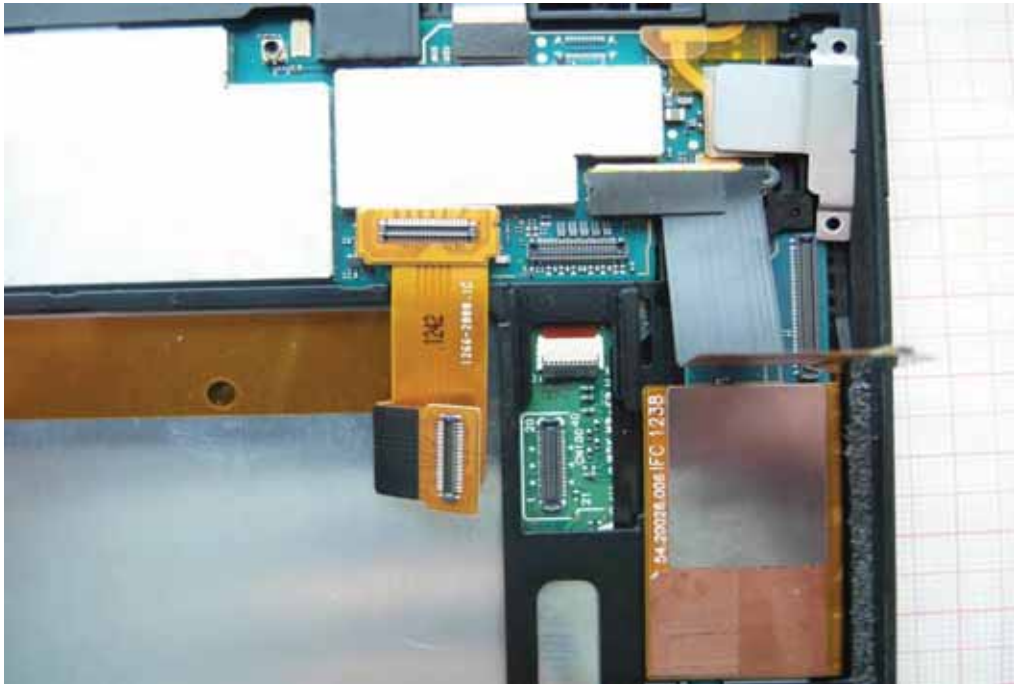

Photo 46:

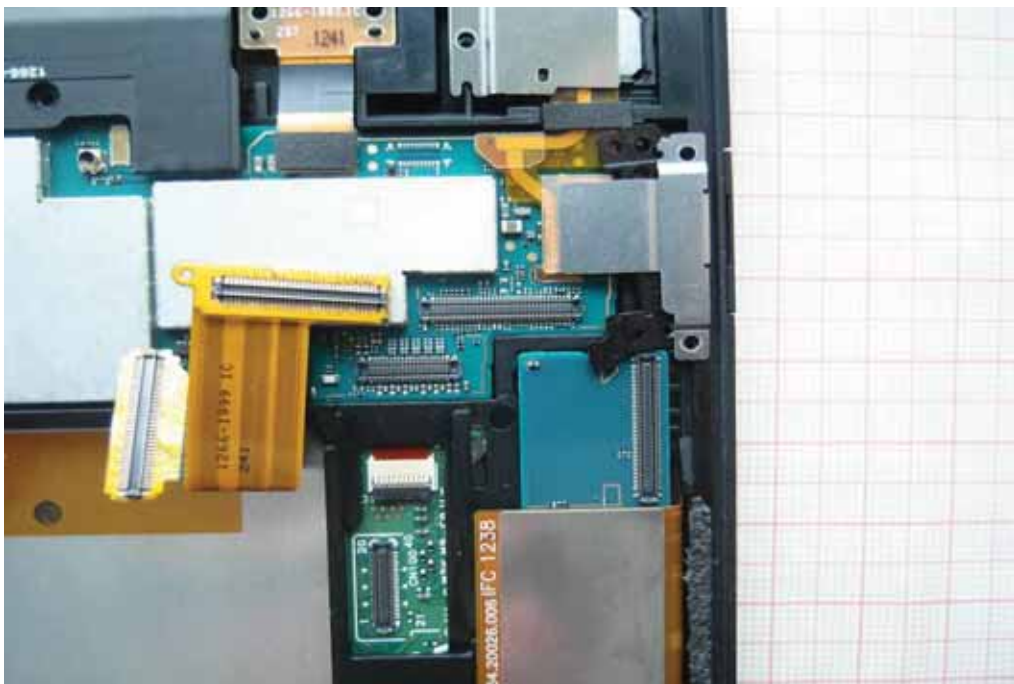

Photo 47:

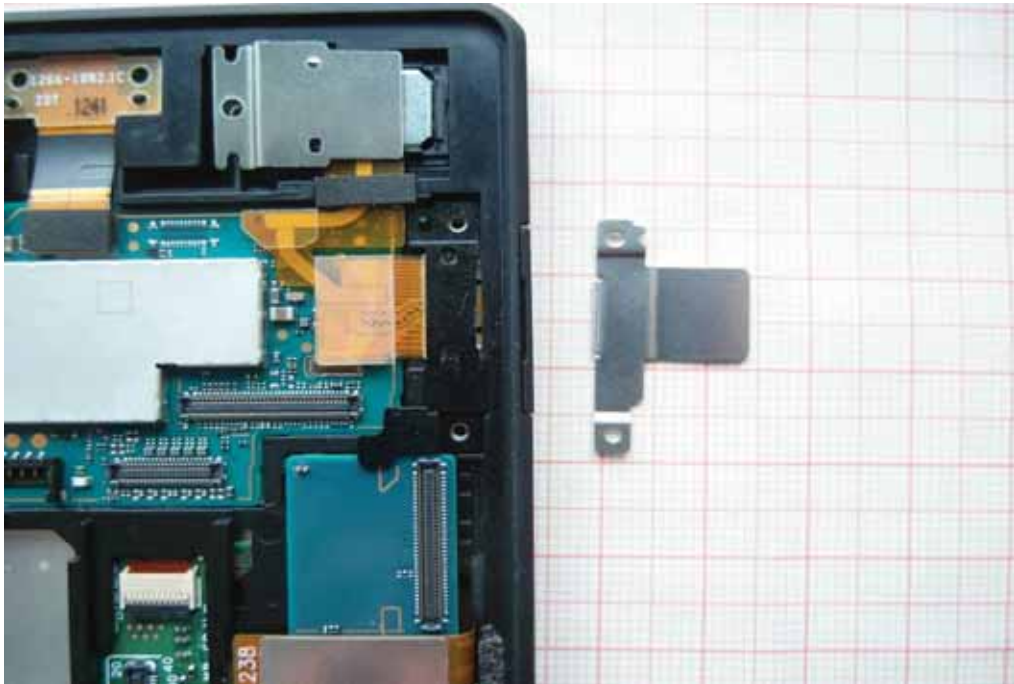

Photo 48:



Photo 49:

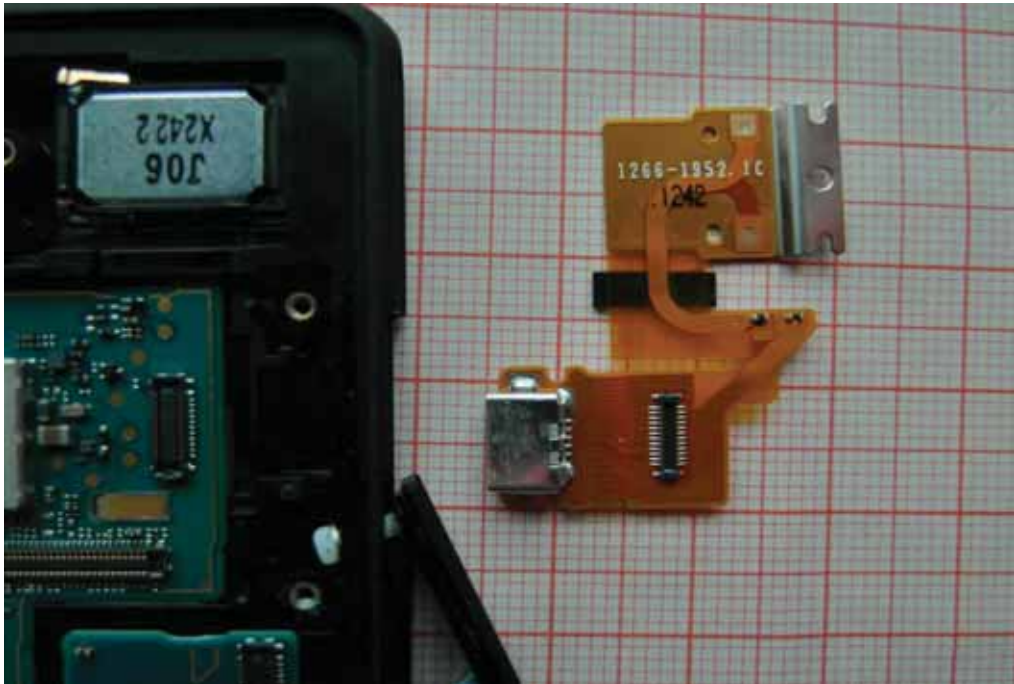

Photo 50:



Photo 51:



Photo 52:

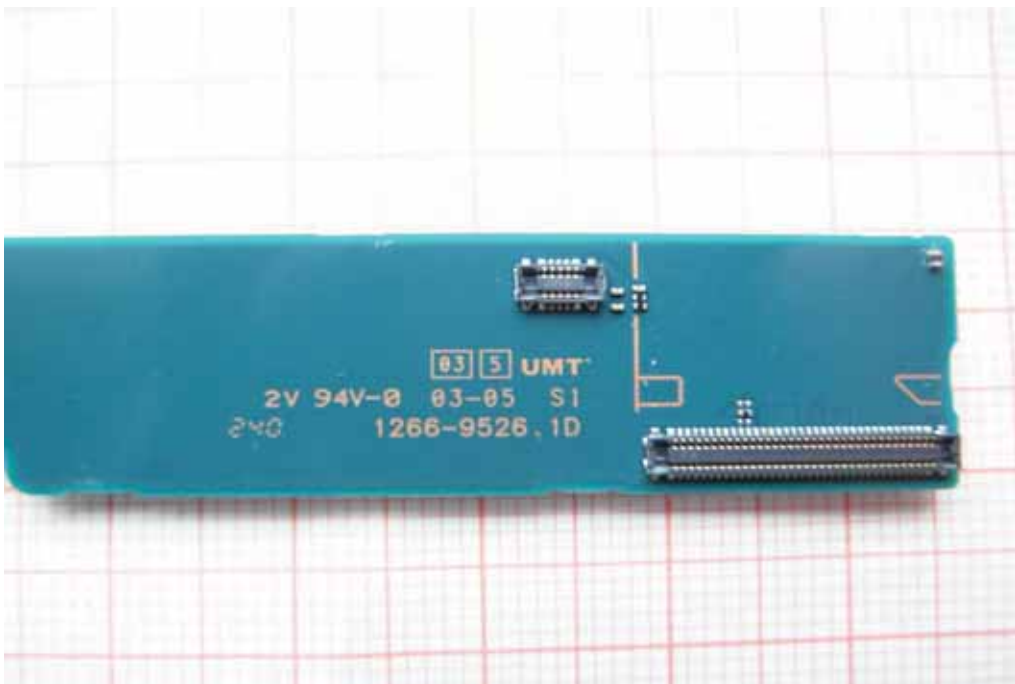

Photo 53:

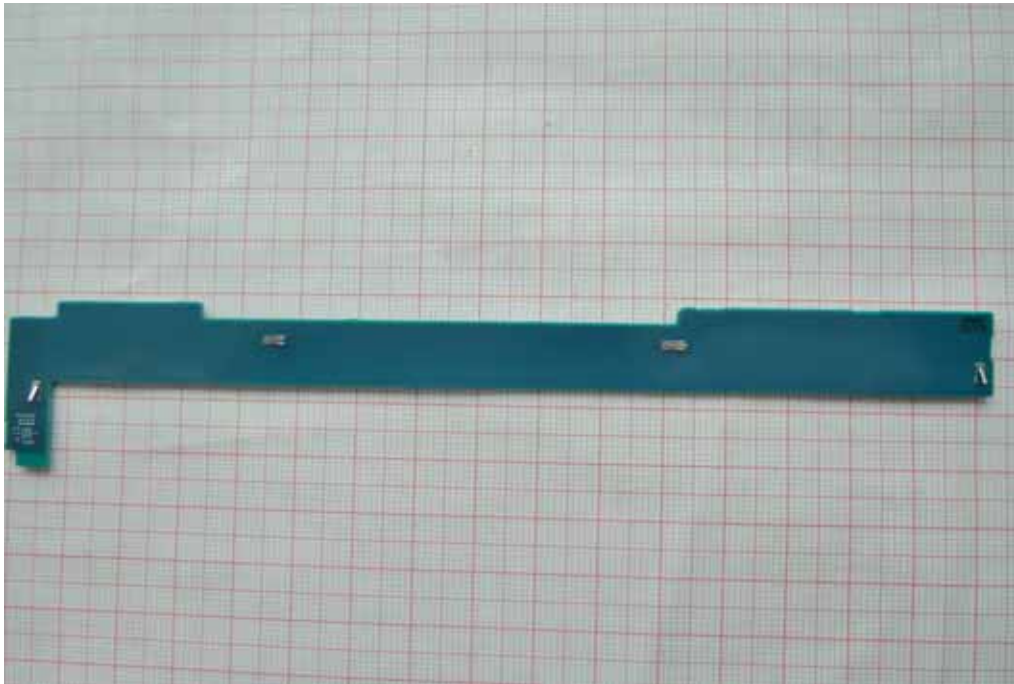

Photo 54:

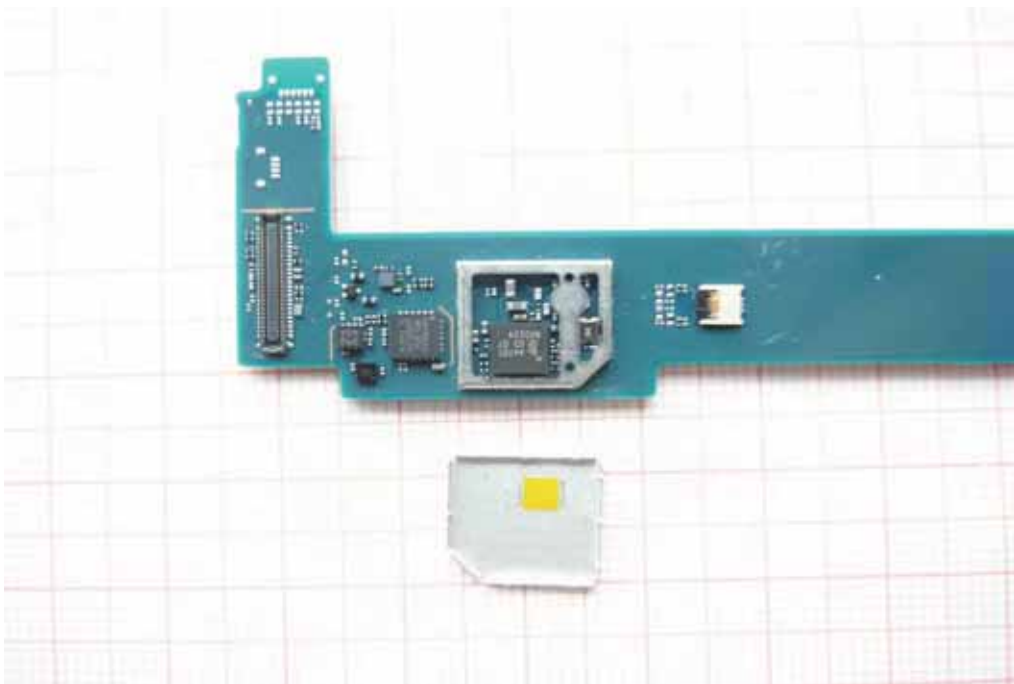

Photo 55:

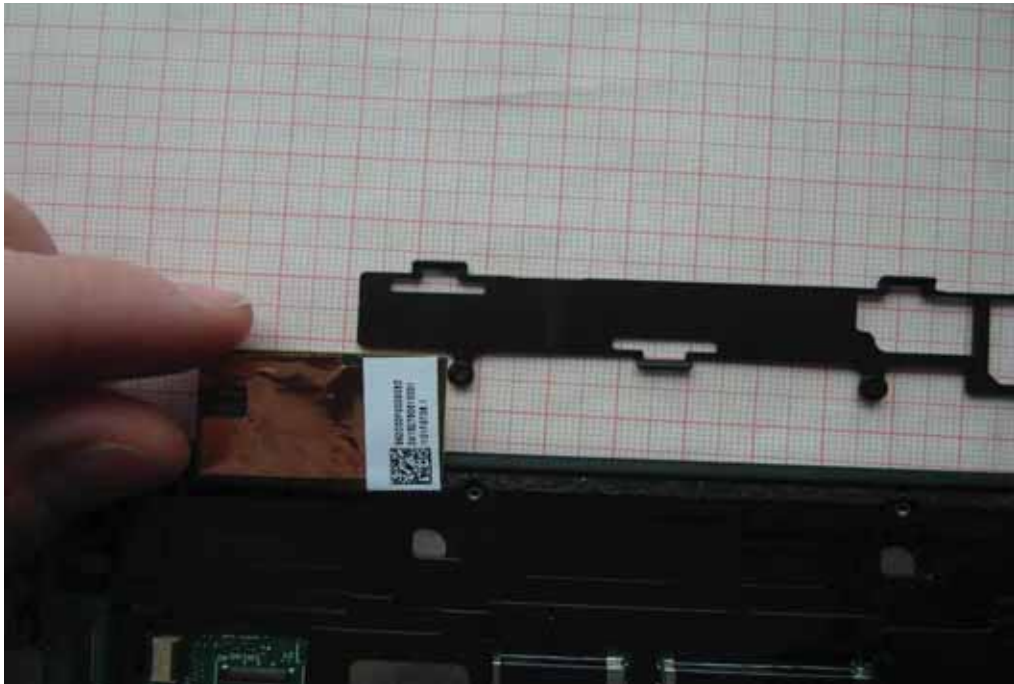

Photo 56:



Photo 57:

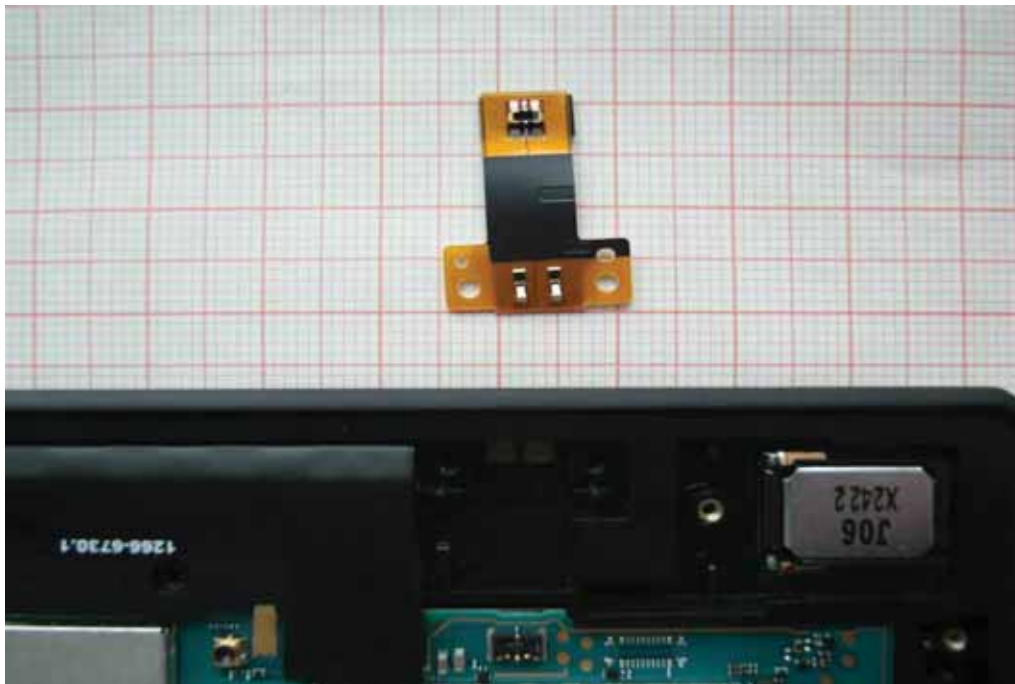

Photo 58:

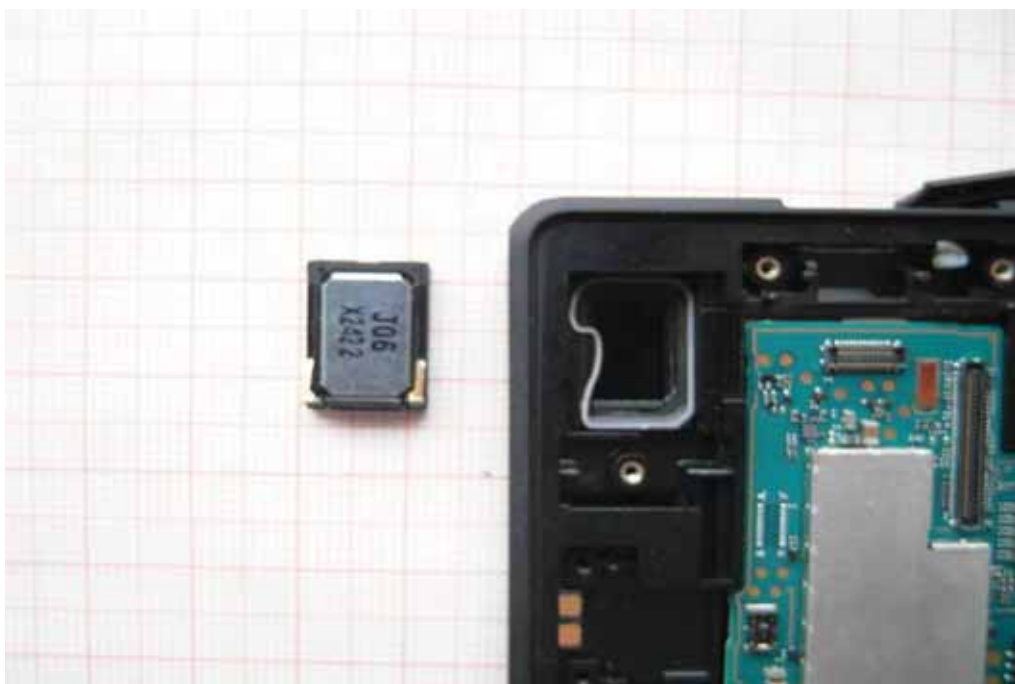

Photo 59:

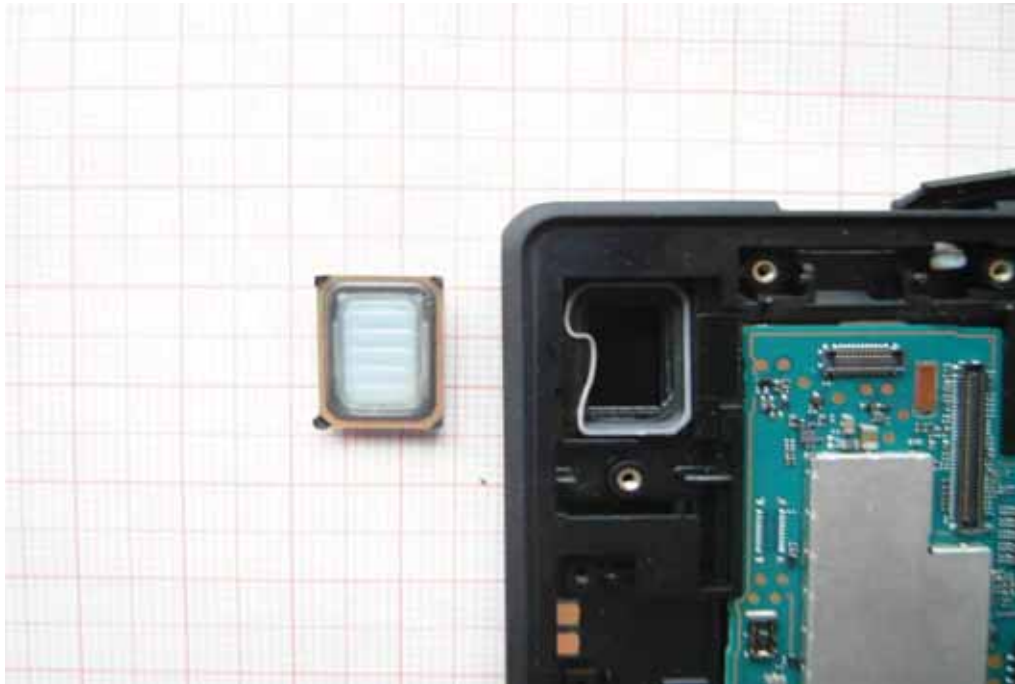

Photo 60:

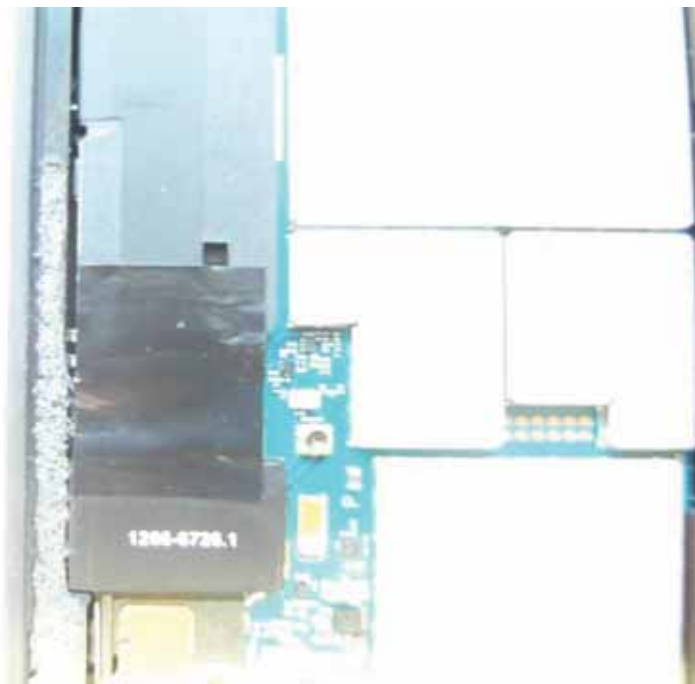

Photo 61:



Photo 62:

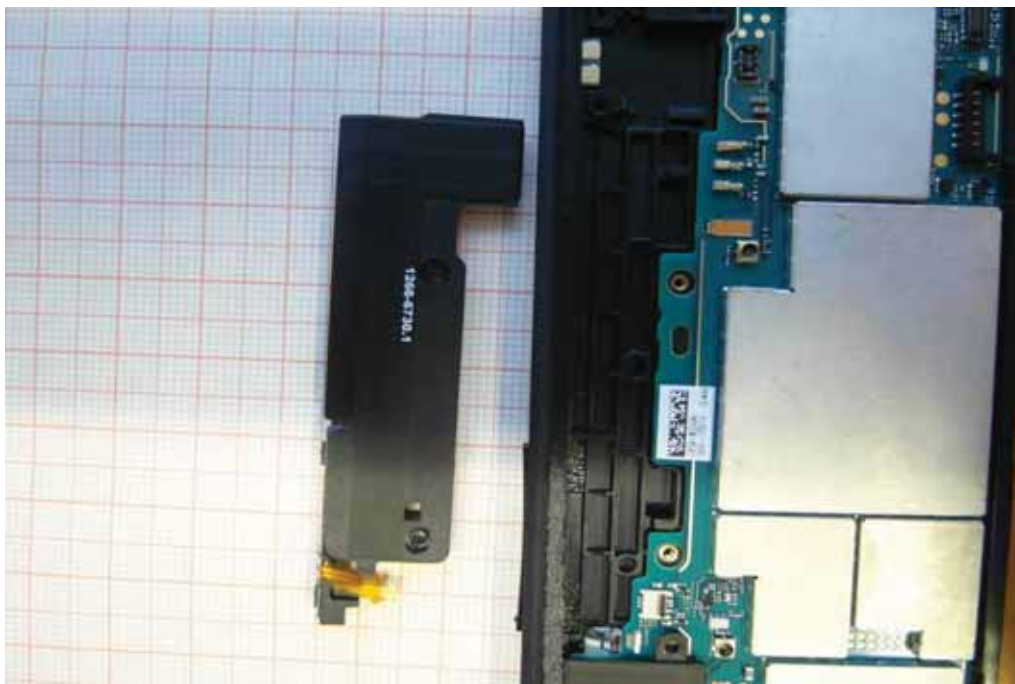

Photo 63:

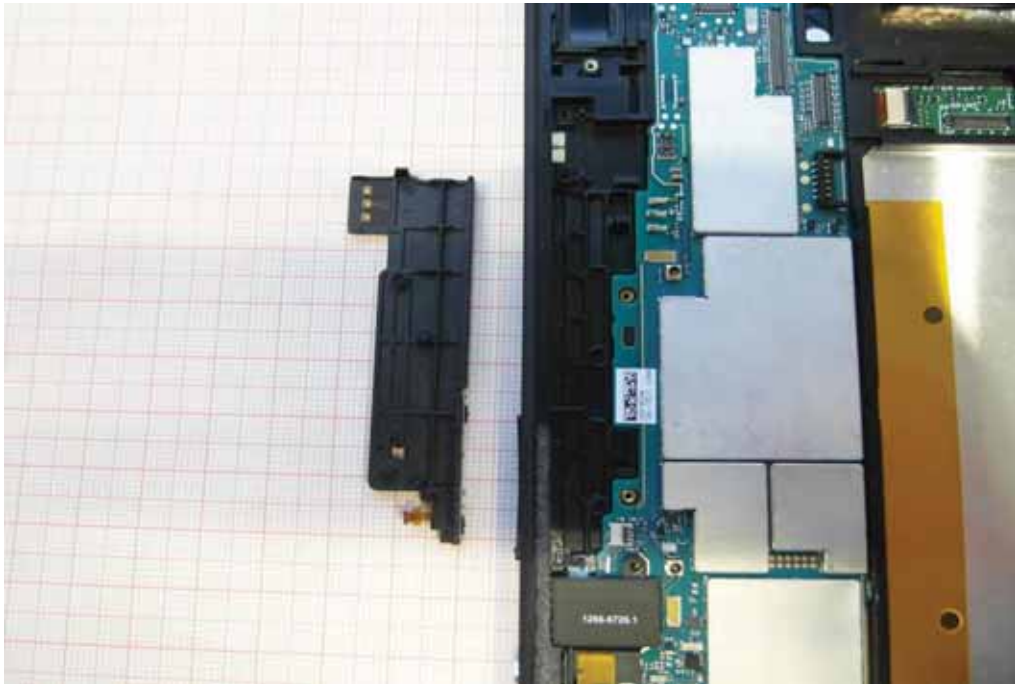

Photo 64:

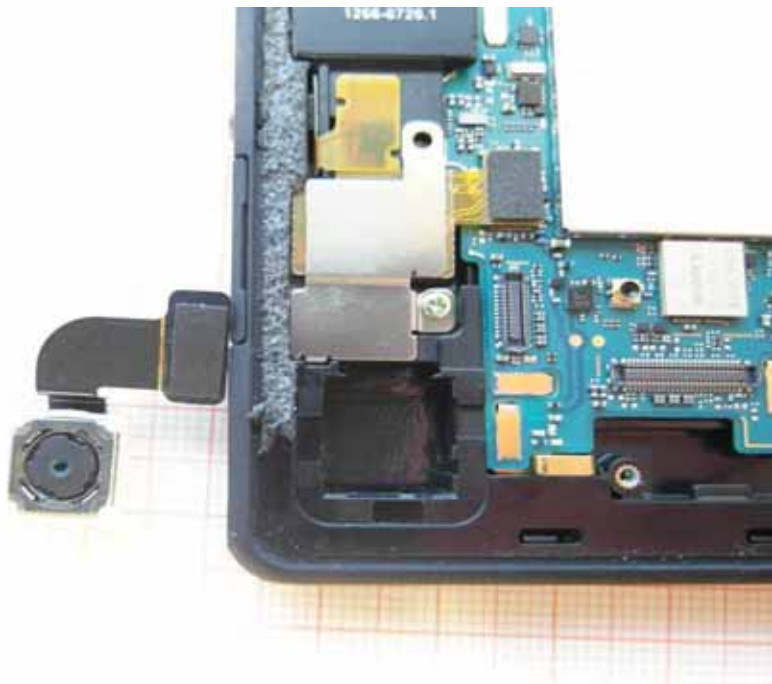

Photo 65:

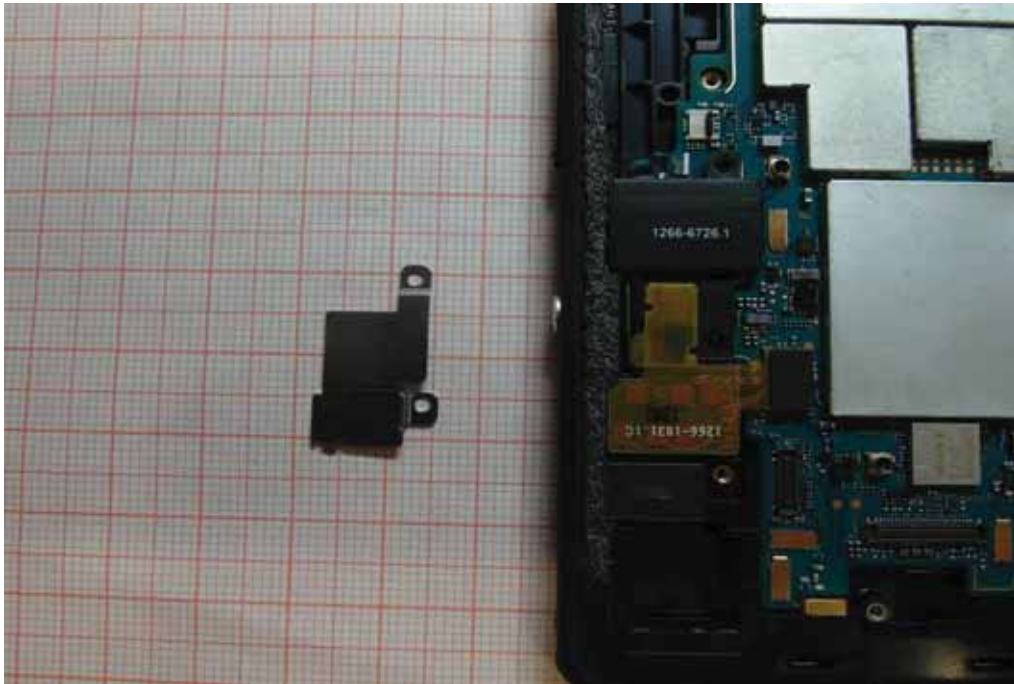

Photo 66:

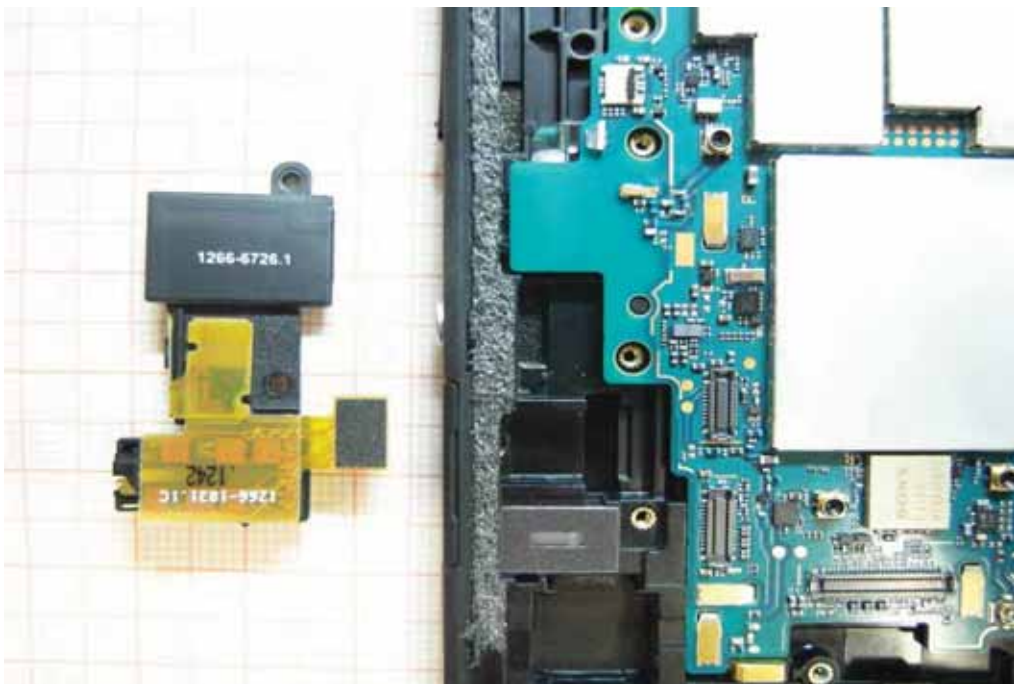

Photo 67:



Photo 68:

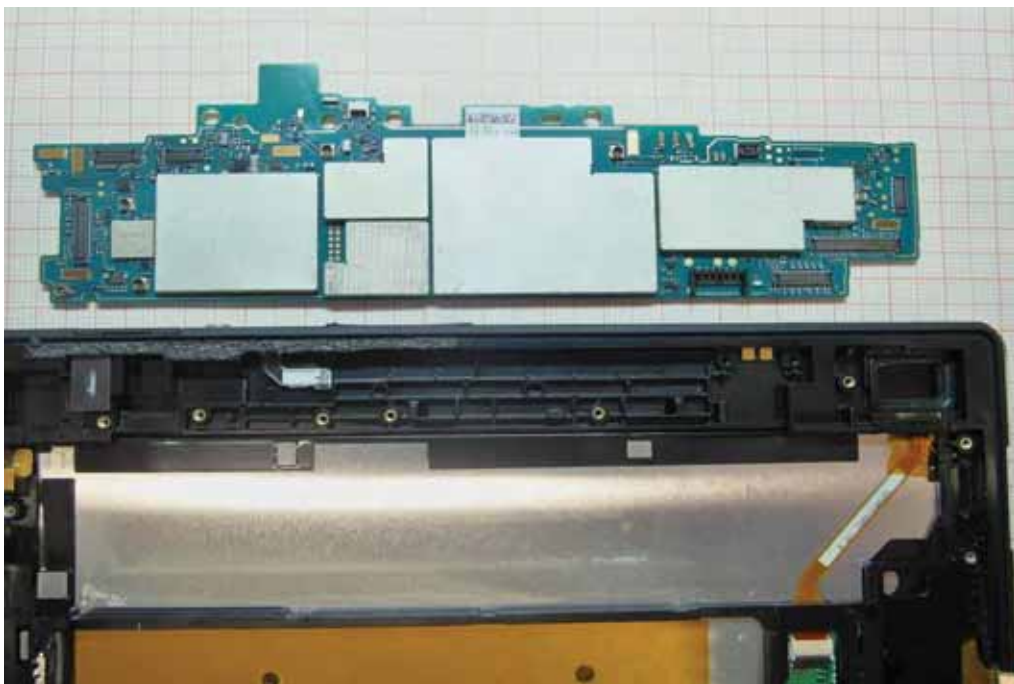

Photo 69:

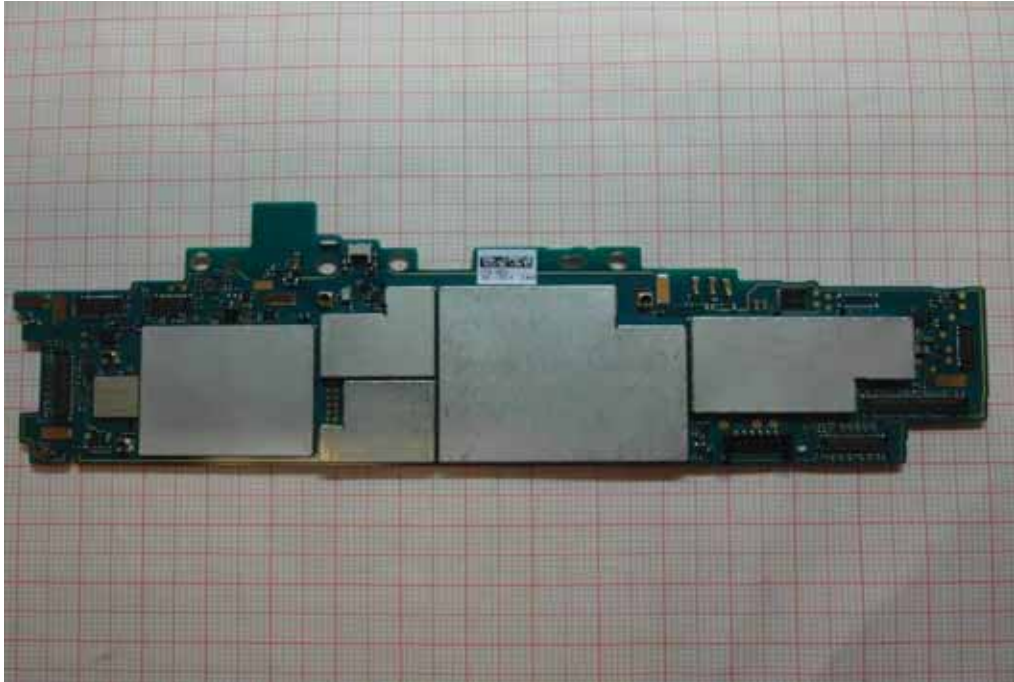

Photo 70:

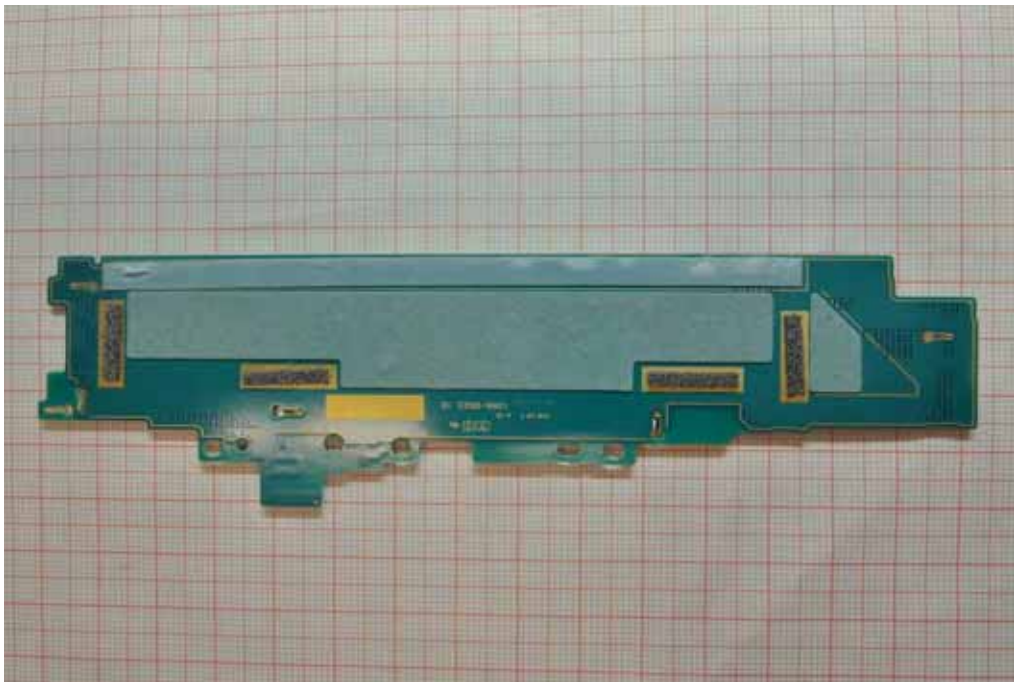

Photo 71:

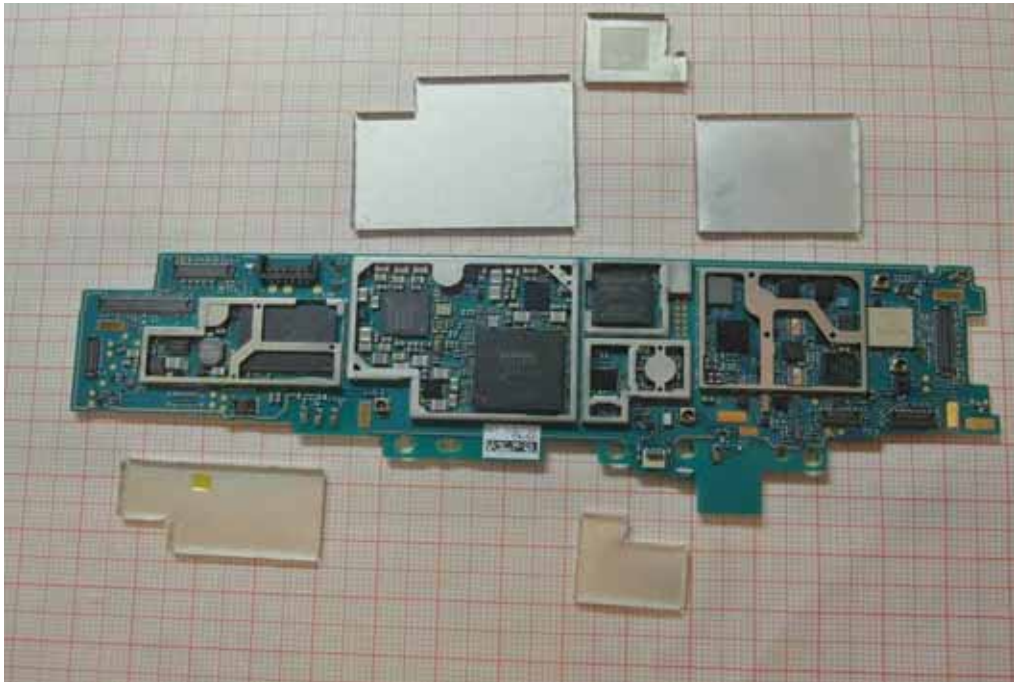

Photo 72:

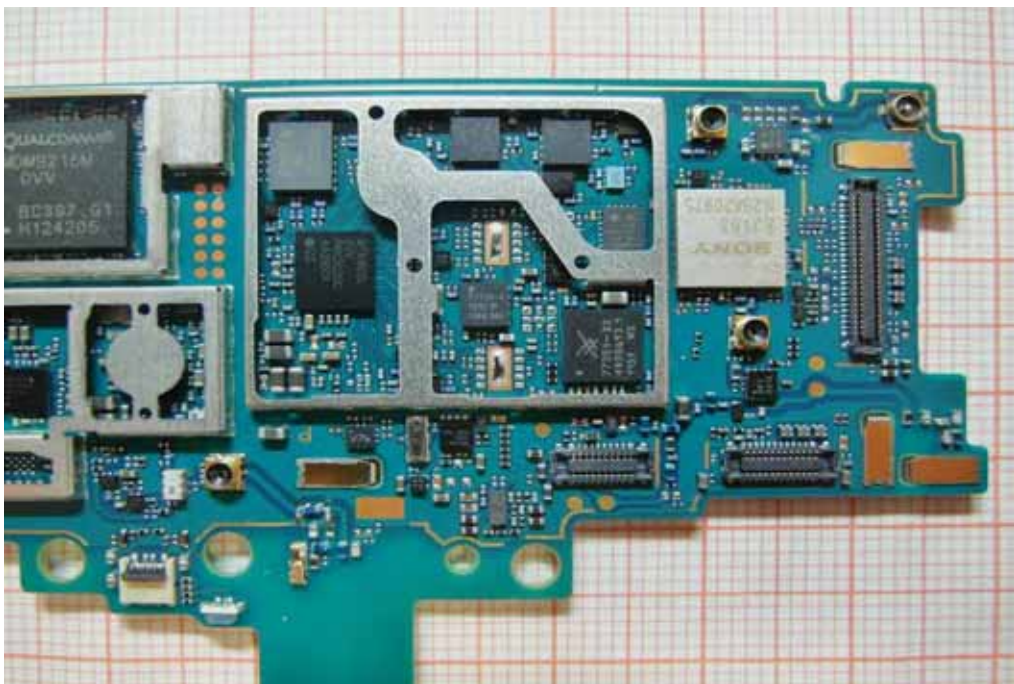

Photo 73:



Photo 74:

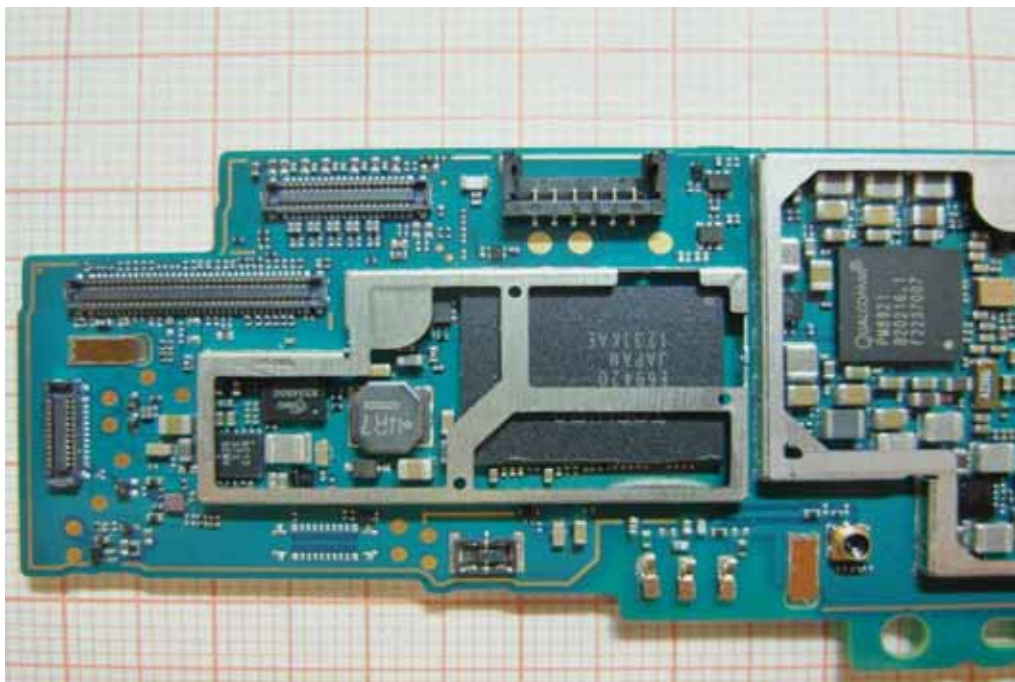

Photo 75:



Photo 76:



Photo 77:



Annex D Document history

Version	Applied changes	Date of release
1.0	Initial release	2013-01-18

Annex E Further information

Glossary

AVG	-	Average
DUT	-	Device under test
EMC	-	Electromagnetic Compatibility
EN	-	European Standard
EUT	-	Equipment under test
ETSI	-	European Telecommunications Standard Institute
FCC	-	Federal Communication Commission
FCC ID	-	Company Identifier at FCC
HW	-	Hardware
IC	-	Industry Canada
Inv. No.	-	Inventory number
N/A	-	Not applicable
PP	-	Positive peak
QP	-	Quasi peak
S/N	-	Serial number
SW	-	Software

Annex F Accreditation Certificate



Front side of certificate



Back side of certificate

Note:

The current certificate including annex is published on our website (see link below) or may be received from CETECOM ICT Services on request.

http://www.cetecom.com/fileadmin/de/CETECOM_D_Saarbruecken/accreditations_Jan_2010/DAKKS_Akkredi_Urk_EN17025-En_incl_Annex.pdf