



FCC RF Test Report

APPLICANT : Sony Mobile Communications Inc.
EQUIPMENT : Smart phone
BRAND NAME : Sony
FCC ID : PY7-PM0952
STANDARD : FCC 47 CFR Part 2, 22(H), 24(E)
CLASSIFICATION : PCS Licensed Transmitter Held to Ear (PCE)

The product was received on Feb. 04, 2016 and testing was completed on Feb. 25, 2016. We, SPORTON INTERNATIONAL INC., would like to declare that the tested sample has been evaluated in accordance with the test procedures given in ANSI / TIA / EIA-603-D-2010 and has been in compliance with the applicable technical standards.

The test results in this report apply exclusively to the tested model / sample. Without written approval of SPORTON INTERNATIONAL INC., the test report shall not be reproduced except in full.

Reviewed by: Joseph Lin / Supervisor

Approved by: Jones Tsai / Manager



SPORTON INTERNATIONAL INC.

No. 52, Hwa Ya 1st Rd., Hwa Ya Technology Park, Kwei-Shan District, Tao Yuan City, Taiwan, R.O.C.



TABLE OF CONTENTS

REVISION HISTORY..... 3

SUMMARY OF TEST RESULT 4

1 GENERAL DESCRIPTION 5

 1.1 Applicant..... 5

 1.2 Manufacturer 5

 1.3 Product Feature of Equipment Under Test 5

 1.4 Modification of EUT 6

 1.5 Maximum ERP/EIRP Power, Frequency Tolerance, and Emission Designator 6

 1.6 Testing Location 7

 1.7 Applicable Standards 7

2 TEST CONFIGURATION OF EQUIPMENT UNDER TEST 8

 2.1 Test Mode..... 8

 2.2 Connection Diagram of Test System 9

 2.3 Support Unit used in test configuration 9

 2.4 Measurement Results Explanation Example 9

3 CONDUCTED TEST RESULT 10

 3.1 Measuring Instruments..... 10

 3.2 Test Setup 10

 3.3 Test Result of Conducted Test..... 10

 3.4 Conducted Output Power 11

 3.5 Peak-to-Average Ratio 11

 3.6 99% Occupied Bandwidth and 26dB Bandwidth Measurement..... 12

 3.7 Conducted Band Edge 13

 3.8 Conducted Spurious Emission 14

 3.9 Frequency Stability..... 15

4 RADIATED TEST ITEMS 16

 4.1 Measuring Instruments..... 16

 4.2 Test Setup 16

 4.3 Test Result of Radiated Test..... 16

 4.4 Effective Radiated Power and Effective Isotropic Radiated Power Measurement 17

 4.5 Field Strength of Spurious Radiation Measurement 19

5 LIST OF MEASURING EQUIPMENT 20

6 UNCERTAINTY OF EVALUATION 22

APPENDIX A. TEST RESULTS OF CONDUCTED TEST

APPENDIX B. TEST RESULTS OF RADIATED TEST



SUMMARY OF TEST RESULT

Report Section	FCC Rule	Description	Limit	Result	Remark
3.4	§2.1046	Conducted Output Power	Reporting Only	PASS	-
3.5	§24.232(d)	Peak-to-Average Ratio	< 13 dB	PASS	-
3.6	§2.1049 §22.917(b) §24.238(b)	Occupied Bandwidth	Reporting Only	PASS	-
3.7	§2.1051 §22.917(a) §24.238(a)	Band Edge Measurement	< 43+10log10(P[Watts])	PASS	-
3.8	§2.1051 §22.917(a) §24.238(a)	Conducted Emission	< 43+10log10(P[Watts])	PASS	-
3.9	§2.1055 §22.355	Frequency Stability for Temperature & Voltage	< 2.5 ppm for Part 22	PASS	-
	§2.1055 §24.235		Within Authorized Band		
4.4	§22.913(a)(2)	Effective Radiated Power	< 7 Watts	PASS	-
	§24.232(c)	Equivalent Isotropic Radiated Power	< 2 Watts		
4.5	§2.1053 §22.917(a) §24.238(a)	Field Strength of Spurious Radiation	< 43+10log10(P[Watts])	PASS	Under limit 13.86 dB at 7403.000 MHz



1 General Description

1.1 Applicant

Sony Mobile Communications Inc.

4-12-3 Higashi-Shinagawa, Shinagawa-ku, Tokyo, 140-0002, Japan

1.2 Manufacturer

Sony Mobile Communications Inc.

4-12-3 Higashi-Shinagawa, Shinagawa-ku, Tokyo, 140-0002, Japan

1.3 Product Feature of Equipment Under Test

GSM/WCDMA/LTE, Bluetooth, DTS/UNII, a/b/g/n, GPS and NFC

Product Specification subjective to this standard	
Antenna Type	Coupling type (LDS) Antenna

EUT Information List				
IMEI	HW Version	SW Version	S/N	Performed Test Item
004402455813026	A	36.0.A.1.28	WUJ01M855M	Conducted Measurement
				Radiated Spurious Emission
				ERP/EIRP Test

Accessory List	
AC Adapter	Model No. : UCH20
	Type No. : AC-0061-US
	S/N : 1315W52500078
Earphone	Model No. : MH410c
	Type No. : AG-1110
	S/N : 14352048042A6B8
USB Cable	Model No. : UCB16
	Type No. : AI-0142
	S/N : 1602A907000508E

Note:

1. Above EUT list and accessory list used are electrically identical per declared by manufacturer.
2. Above the accessories list are used to exercise the EUT during test.
3. For other wireless features of this EUT, test report will be issued separately.



1.4 Modification of EUT

No modifications are made to the EUT during all test items.

1.5 Maximum ERP/EIRP Power, Frequency Tolerance, and Emission Designator

FCC Rule	System	Type of Modulation	Maximum ERP/EIRP (W)	Frequency Tolerance (ppm)	Emission Designator
Part 22	GSM850 GSM	GMSK	0.4246	0.0084 ppm	246KGXW
Part 22	GSM850 EDGE class 8	8PSK	0.1256	0.0072 ppm	249KG7W
Part 22	WCDMA Band V RMC 12.2Kbps	QPSK	0.0535	0.0120 ppm	4M17F9W
Part 24	GSM1900 GSM	GMSK	0.5433	0.0043 ppm	247KGXW
Part 24	GSM1900 EDGE class 8	8PSK	0.2158	0.0043 ppm	253KG7W
Part 24	WCDMA Band II RMC 12.2Kbps	QPSK	0.1023	0.0080 ppm	4M18F9W



1.6 Testing Location

Sporton Lab is accredited to ISO 17025 by Taiwan Accreditation Foundation (TAF code : 1190) and the FCC designation No. TW1022 under the FCC 2.948(e) by Mutual Recognition Agreement (MRA) in FCC Test.

Test Site	SPORTON INTERNATIONAL INC.
Test Site Location	No. 52, Hwa Ya 1 st Rd., Hwa Ya Technology Park, Kwei-Shan District, Tao Yuan City, Taiwan, R.O.C. TEL: +886-3-327-3456 FAX: +886-3-328-4978
Test Site No.	Sporton Site No.
	TH03-HY

Test Site	SPORTON INTERNATIONAL INC.
Test Site Location	No.58, Aly. 75, Ln. 564, Wenhua 3rd Rd. Guishan Dist, Taoyuan City, Taiwan (R.O.C.) TEL: +886-3-327-0868 FAX: +886-3-327-0855
Test Site No.	Sporton Site No.
	03CH12-HY

1.7 Applicable Standards

According to the specifications of the manufacturer, the EUT must comply with the requirements of the following standards:

- 47 CFR Part 2, 22(H), 24(E)
- ANSI / TIA / EIA-603-D-2010
- FCC KDB 971168 D01 Power Meas. License Digital Systems v02r02

Remark:

1. All test items were verified and recorded according to the standards and without any deviation during the test.
2. This EUT has also been tested and complied with the requirements of FCC Part 15, Subpart B, recorded in a separate test report.



2 Test Configuration of Equipment Under Test

2.1 Test Mode

Antenna port conducted and radiated test items were performed according to KDB 971168 D01 Power Meas. License Digital Systems v02r02 with maximum output power.

Radiated measurements were performed with rotating EUT in different three orthogonal test planes to find the maximum emission.

Radiated emissions were investigated as following frequency range:

1. 30 MHz to 9000 MHz for GSM850 and WCDMA Band V.
2. 30 MHz to 19000 MHz for GSM1900 and WCDMA Band II.

All modes and data rates and positions were investigated.

Test modes are chosen to be reported as the worst case configuration below:

Test Modes		
Band	Radiated TCs	Conducted TCs
GSM 850	<ul style="list-style-type: none">■ GSM Link■ EDGE class 8 Link	<ul style="list-style-type: none">■ GSM Link■ EDGE class 8 Link
GSM 1900	<ul style="list-style-type: none">■ GSM Link■ EDGE class 8 Link	<ul style="list-style-type: none">■ GSM Link■ EDGE class 8 Link
WCDMA Band V	<ul style="list-style-type: none">■ RMC 12.2Kbps Link	<ul style="list-style-type: none">■ RMC 12.2Kbps Link
WCDMA Band II	<ul style="list-style-type: none">■ RMC 12.2Kbps Link	<ul style="list-style-type: none">■ RMC 12.2Kbps Link

2.2 Connection Diagram of Test System

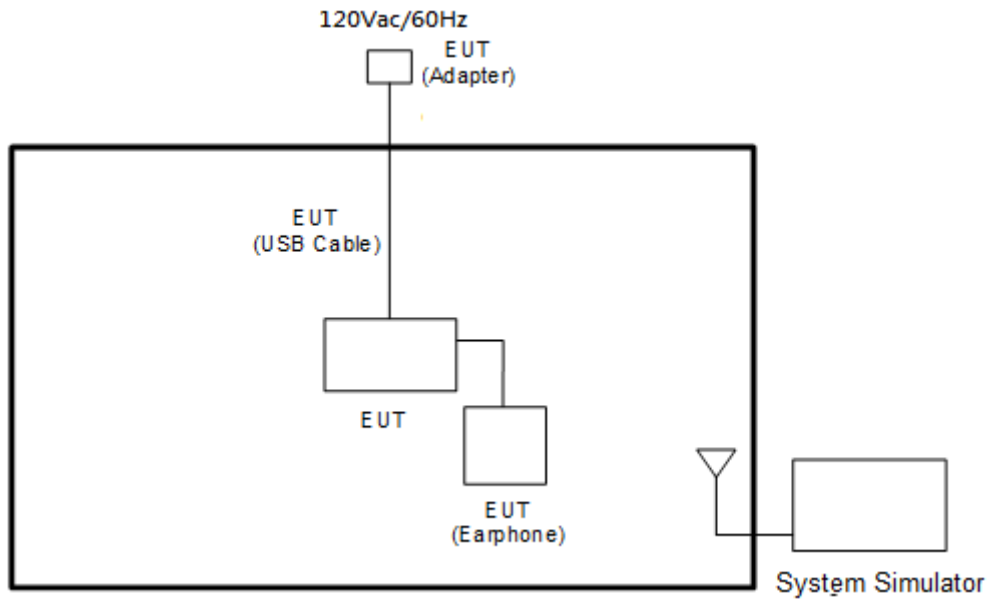

2.3 Support Unit used in test configuration

Item	Equipment	Trade Name	Model No.	FCC ID	Data Cable	Power Cord
1.	System Simulator	R&S	CMU 200	N/A	N/A	Unshielded, 1.8 m

2.4 Measurement Results Explanation Example

For all conducted test items:

The offset level is set in the spectrum analyzer to compensate the RF cable loss and attenuator factor between RF conducted output port and spectrum analyzer. With the offset compensation, the spectrum analyzer reading level will be exactly the RF output level.

The spectrum analyzer offset is derived from RF cable loss and attenuator factor.

Offset = RF cable loss + attenuator factor.

The following shows an offset computation example with RF cable loss 4.2 dB and a 10dB attenuator.

Example :

$$\begin{aligned} \text{Offset(dB)} &= \text{RF cable loss(dB)} + \text{attenuator factor(dB)} \\ &= 4.2 + 10 = 14.2 \text{ (dB)} \end{aligned}$$

3 Conducted Test Result

3.1 Measuring Instruments

See list of measuring instruments of this test report.

3.2 Test Setup

3.2.1 Conducted Output Power

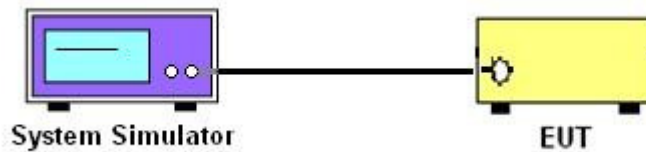

3.2.2 Peak-to-Average Ratio, Occupied Bandwidth, Conducted Band-Edge and Conducted Spurious Emission

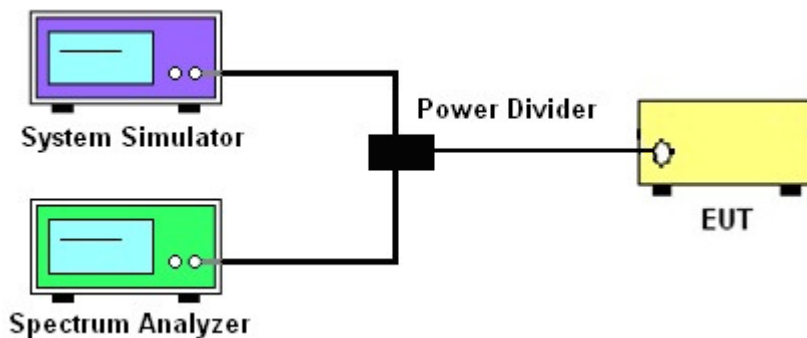

3.2.3 Frequency Stability

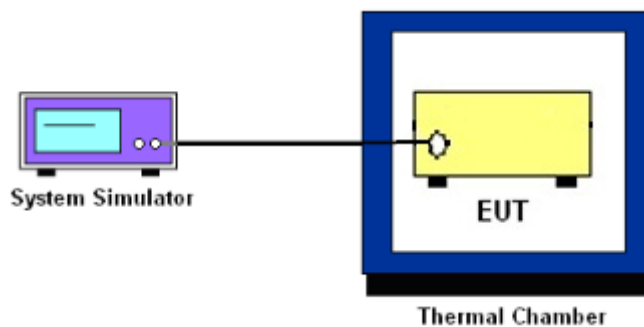

3.3 Test Result of Conducted Test

Please refer to Appendix A.



3.4 Conducted Output Power

3.4.1 Description of the Conducted Output Power

A system simulator was used to establish communication with the EUT. Its parameters were set to enforce EUT transmitting at the maximum power. The measured power in the radio frequency on the transmitter output terminals shall be reported.

3.4.2 Test Procedures

1. The transmitter output port was connected to the system simulator.
2. Set EUT at maximum power through system simulator.
3. Select lowest, middle, and highest channels for each band and different modulation.
4. Measure the maximum burst average power for GSM and maximum average power for other modulation signal.

3.5 Peak-to-Average Ratio

3.5.1 Description of the PAR Measurement

The peak-to-average ratio (PAR) of the transmission may not exceed 13 dB.

3.5.2 Test Procedures

1. The testing follows FCC KDB 971168 D01 v02r02 Section 5.7.1.
2. The EUT was connected to spectrum analyzer and system simulator via a power divider.
3. Set EUT to transmit at maximum output power.
4. When the duty cycle is less than 98%, then signal gating will be implemented on the spectrum analyzer by triggering from the system simulator.
5. Set the CCDF (Complementary Cumulative Distribution Function) option of the spectrum analyzer.
Record the maximum PAPR level associated with a probability of 0.1%.



3.6 99% Occupied Bandwidth and 26dB Bandwidth Measurement

3.6.1 Description of 99% Occupied Bandwidth and 26dB Bandwidth Measurement

The occupied bandwidth is the width of a frequency band such that, below the lower and above the upper frequency limits, the mean powers emitted are each equal to a specified percentage 0.5% of the total mean transmitted power.

The 26 dB emission bandwidth is defined as the frequency range between two points, one above and one below the carrier frequency, at which the spectral density of the emission is attenuated 26 dB below the maximum in-band spectral density of the modulated signal. Spectral density (power per unit bandwidth) is to be measured with a detector of resolution bandwidth equal to approximately 1.0% of the emission bandwidth.

3.6.2 Test Procedures

1. The testing follows FCC KDB 971168 v02r02 Section 4.2.
2. The EUT was connected to spectrum analyzer and system simulator via a power divider.
3. The spectrum analyzer center frequency is set to the nominal EUT channel center frequency. The span range for the spectrum analyzer shall be between two and five times the anticipated OBW.
4. The nominal resolution bandwidth (RBW) shall be in the range of 1 to 5 % of the anticipated OBW, and the VBW shall be at least 3 times the RBW.
5. Set the detection mode to peak, and the trace mode to max hold.
6. Determine the reference value: Set the EUT to transmit a modulated signal. Allow the trace to stabilize. Set the spectrum analyzer marker to the highest level of the displayed trace.
(this is the reference value)
7. Determine the “-26 dB down amplitude” as equal to (Reference Value – X).
8. Place two markers, one at the lowest and the other at the highest frequency of the envelope of the spectral display such that each marker is at or slightly below the “-X dB down amplitude” determined in step 6. If a marker is below this “-X dB down amplitude” value it shall be placed as close as possible to this value. The OBW is the positive frequency difference between the two markers.
9. Use the 99 % power bandwidth function of the spectrum analyzer and report the measured bandwidth.



3.7 Conducted Band Edge

3.7.1 Description of Conducted Band Edge Measurement

The power of any emission outside of the authorized operating frequency ranges must be lower than the transmitter power (P) by a factor of at least $43 + 10 \log (P)$ dB.

3.7.2 Test Procedures

1. The testing follows FCC KDB 971168 D01 v02r02 Section 6.0.
2. The EUT was connected to the spectrum analyzer and system simulator via a power divider.
3. The RF output of EUT was connected to the spectrum analyzer by an RF cable and attenuator. The path loss was compensated to the results for each measurement.
4. The band edges of low and high channels for the highest RF powers were measured.
5. The RF fundamental frequency should be excluded against the limit line in the operating frequency band.
6. The limit line is derived from $43 + 10\log(P)$ dB below the transmitter power P(Watts)
= $P(W) - [43 + 10\log(P)]$ (dB)
= $[30 + 10\log(P)]$ (dBm) - $[43 + 10\log(P)]$ (dB)
= -13dBm.



3.8 Conducted Spurious Emission

3.8.1 Description of Conducted Spurious Emission Measurement

The power of any emission outside of the authorized operating frequency ranges must be lower than the transmitter power (P) by a factor of at least $43 + 10 \log (P)$ dB.

It is measured by means of a calibrated spectrum analyzer and scanned from 30 MHz up to a frequency including its 10th harmonic.

3.8.2 Test Procedures

1. The testing follows FCC KDB 971168 D01 v02r02 Section 6.0.
2. The EUT was connected to the spectrum analyzer and system simulator via a power divider.
3. The RF output of EUT was connected to the spectrum analyzer by an RF cable and attenuator. The path loss was compensated to the results for each measurement.
4. The middle channel for the highest RF power within the transmitting frequency was measured.
5. The conducted spurious emission for the whole frequency range was taken.
6. The RF fundamental frequency should be excluded against the limit line in the operating frequency band.
7. The limit line is derived from $43 + 10\log(P)$ dB below the transmitter power P(Watts)
= $P(W) - [43 + 10\log(P)]$ (dB)
= $[30 + 10\log(P)]$ (dBm) - $[43 + 10\log(P)]$ (dB)
= -13dBm.



3.9 Frequency Stability

3.9.1 Description of Frequency Stability Measurement

The frequency stability shall be measured by variation of ambient temperature and variation of primary supply voltage to ensure that the fundamental emission stays within the authorized frequency block. The frequency stability of the transmitter shall be maintained within $\pm 0.00025\%$ ($\pm 2.5\text{ppm}$) of the center frequency.

3.9.2 Test Procedures for Temperature Variation

1. The testing follows FCC KDB 971168 D01 v02r02 Section 9.0.
2. The EUT was set up in the thermal chamber and connected with the system simulator.
3. With power OFF, the temperature was decreased to -30°C and the EUT was stabilized before testing. Power was applied and the maximum change in frequency was recorded within one minute.
4. With power OFF, the temperature was raised in 10°C steps up to 50°C . The EUT was stabilized at each step for at least half an hour. Power was applied and the maximum frequency change was recorded within one minute.

3.9.3 Test Procedures for Voltage Variation

1. The testing follows FCC KDB 971168 D01 v02r02 Section 9.0.
2. The EUT was placed in a temperature chamber at $25\pm 5^{\circ}\text{C}$ and connected with the system simulator.
3. The power supply voltage to the EUT was varied from 85% to 115% of the nominal value measured at the input to the EUT.
4. The variation in frequency was measured for the worst case.

4 Radiated Test Items

4.1 Measuring Instruments

See list of measuring instruments of this test report.

4.2 Test Setup

4.2.1 For radiated test from 30MHz to 1GHz

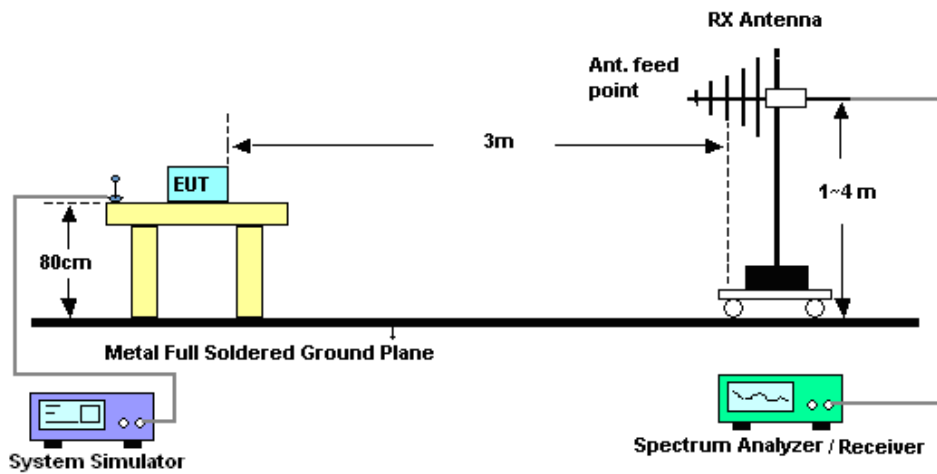

4.2.2 For radiated test above 1GHz

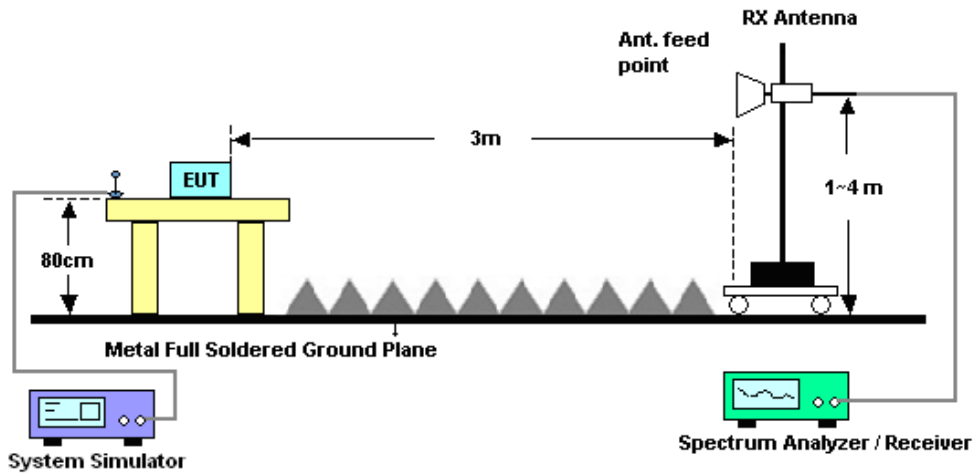

4.3 Test Result of Radiated Test

Please refer to Appendix B.



4.4 Effective Radiated Power and Effective Isotropic Radiated Power Measurement

4.4.1 Description of the ERP/EIRP Measurement

The substitution method, in ANSI / TIA / EIA-603-D-2010, was used for ERP/EIRP measurement, and the spectrum analyzer configuration follows KDB 971168 D01 Power Meas. License Digital Systems v02r02. The ERP of mobile transmitters must not exceed 7 Watts (Cellular Band) and the EIRP of mobile transmitters are limited to 2 Watts (PCS Band).

4.4.2 Test Procedures

1. The testing follows FCC KDB 971168 D01 v02r02 Section 5.2.1. (for CDMA/WCDMA), Section 5.2.2.2 (for GSM/GPRS/EDGE) and ANSI / TIA-603-D-2010 Section 2.2.17.
2. The EUT was placed on a non-conductive rotating platform 0.8 meters high in a semi-anechoic chamber. The radiated emission at the fundamental frequency was measured at 3 m with a test antenna and a spectrum analyzer with RMS detector per section 5. of KDB 971168 D01.
3. During the measurement, the system simulator parameters were set to force the EUT transmitting at maximum output power. The maximum emission was recorded from analyzer power level (LVL) from the 360 degrees rotation of the turntable and the test antenna raised and lowered over a range from 1 to 4 meters in both horizontally and vertically polarized orientations.
4. Effective Isotropic Radiated Power (EIRP) was measured by substitution method according to TIA/EIA-603-D. The EUT was replaced by the substitution antenna at same location, and then a known power from S.G. was applied into the dipole antenna through a Tx cable, and then recorded the maximum Analyzer reading through raised and lowered the test antenna. The correction factor (in dB) = S.G. - Tx Cable loss + Substitution antenna gain - Analyzer reading. Then the EUT's EIRP was calculated with the correction factor, $EIRP = LVL + \text{Correction factor}$ and $ERP = EIRP - 2.15$. Take the record of the output power at substitution antenna.



	GSM/GPRS/EDGE	WCDMA/HSPA
SPAN	500kHz	10MHz
RBW	10kHz	100kHz
VBW	30kHz	300kHz
Detector	RMS	RMS
Trace	Average	Average
Average Type	Power	Power
Sweep Count	100	100



4.5 Field Strength of Spurious Radiation Measurement

4.5.1 Description of Field Strength of Spurious Radiated Measurement

The power of any emission outside of the authorized operating frequency ranges must be attenuated below the transmitter power (P) by a factor of at least $43 + 10 \log (P)$ dB. The spectrum is scanned from 30 MHz up to a frequency including its 10th harmonic.

4.5.2 Test Procedures

1. The testing follows FCC KDB 971168 D01 v02r02 Section 5.8 and ANSI / TIA-603-D-2010 Section 2.2.12.
2. The EUT was placed on a rotatable wooden table 0.8 meters above the ground.
3. The EUT was set 3 meters from the receiving antenna, which was mounted on the antenna tower.
4. The table was rotated 360 degrees to determine the position of the highest spurious emission.
5. The height of the receiving antenna is varied between one meter and four meters to search for the maximum spurious emission for both horizontal and vertical polarizations.
6. Make the measurement with the spectrum analyzer's RBW = 1MHz, VBW = 3MHz, taking record of maximum spurious emission.
7. A horn antenna was substituted in place of the EUT and was driven by a signal generator.
8. Tune the output power of signal generator to the same emission level with EUT maximum spurious emission.
9. Taking the record of output power at antenna port.
10. Repeat step 7 to step 8 for another polarization.
11. $EIRP (dBm) = S.G. Power - Tx Cable Loss + Tx Antenna Gain$
12. $ERP (dBm) = EIRP - 2.15$
13. The RF fundamental frequency should be excluded against the limit line in the operating frequency band.
14. The limit line is derived from $43 + 10\log(P)$ dB below the transmitter power P(Watts)
 $= P(W) - [43 + 10\log(P)] (dB)$
 $= [30 + 10\log(P)] (dBm) - [43 + 10\log(P)] (dB)$
 $= -13dBm.$



5 List of Measuring Equipment

Instrument	Manufacturer	Model No.	Serial No.	Characteristics	Calibration Date	Test Date	Due Date	Remark
Hygrometer	Testo	608-H1	34893241	N/A	May. 04, 2015	Feb. 25, 2016	May. 03, 2016	Conducted (TH03-HY)
Spectrum Analyzer	Rohde & Schwarz	FSP30	101329	9kHz~30GHz	Jun. 24, 2015	Feb. 25, 2016	Jun. 23, 2016	Conducted (TH03-HY)
Temperature Chamber	ESPEC	SU-641	92013721	-30°C ~70°C	Nov. 20, 2015	Feb. 25, 2016	Nov. 19, 2016	Conducted (TH03-HY)
RF Cable	JYEBAO	K30K30-5003-0.5M40	N/A	0.1MHz~40GHz	Mar. 23, 2015	Feb. 25, 2016	Mar. 22, 2016	Conducted (TH03-HY)
Base Station (Measure)	Rohde & Schwarz	CMU200	117995	GSM / GPRS / WCDMA / CDMA	Jul. 26, 2015	Feb. 25, 2016	Jul. 25, 2016	Conducted (TH03-HY)
Bilog Antenna	TESEQ	CBL 6111D	37059	30MHz~1GHz	Dec. 29, 2015	Feb. 17, 2016 ~ Feb. 18, 2016	Dec. 28, 2016	Radiation (03CH12-HY)
Spectrum Analyzer	Keysight	N9010A	MY54200485	10Hz ~ 44GHZ	Oct. 15, 2015	Feb. 17, 2016 ~ Feb. 18, 2016	Oct. 14, 2016	Radiation (03CH12-HY)
Horn Antenna	SCHWARZBECK	BBHA 9120D	9120D-1328	1GHz ~ 18GHz	Nov. 02, 2015	Feb. 17, 2016 ~ Feb. 18, 2016	Nov. 01, 2016	Radiation (03CH12-HY)
Hygrometer	TECEP	DTM-303B	TP140349	N/A	Nov. 17, 2015	Feb. 17, 2016 ~ Feb. 18, 2016	Nov. 16, 2016	Radiation (03CH12-HY)
Preamplifier	COM-POWER	PA-103A	161075	10MHz~1GHz	Apr. 09, 2015	Feb. 17, 2016 ~ Feb. 18, 2016	Apr. 08, 2016	Radiation (03CH12-HY)
SHF-EHF Horn Antenna	SCHWARZBECK	BBHA 9170	BBHA9170584	18GHz- 40GHz	Nov. 02, 2015	Feb. 17, 2016 ~ Feb. 18, 2016	Nov. 01, 2016	Radiation (03CH12-HY)
Controller	EMEC	EM1000	N/A	Control Turn table & Ant Mast	N/A	Feb. 17, 2016 ~ Feb. 18, 2016	N/A	Radiation (03CH12-HY)
Antenna Mast	EMEC	AM-BS-4500-B	N/A	1m~4m	N/A	Feb. 17, 2016 ~ Feb. 18, 2016	N/A	Radiation (03CH12-HY)
Turn Table	EMEC	TT2000	N/A	0-360 degree	N/A	Feb. 17, 2016 ~ Feb. 18, 2016	N/A	Radiation (03CH12-HY)
RF Cable	HUBER + SUHNER	SUCOFLEX 104	MY24958/4,MY28653/4,MY9839/4PE	9kHz~40GHz	Jan. 12, 2016	Feb. 17, 2016 ~ Feb. 18, 2016	Jan. 11, 2017	Radiation (03CH12-HY)
Preamplifier	MITEQ	JS44-1800400 0-33-8P	1840917	18GHz ~ 40GHz	Jun. 02, 2015	Feb. 17, 2016 ~ Feb. 18, 2016	Jun. 01, 2016	Radiation (03CH12-HY)
Preamplifier	MITEQ	AMF-7D-0010 1800-30-10P	1815698	1GHz ~ 18GHz	Dec. 14, 2015	Feb. 17, 2016 ~ Feb. 18, 2016	Dec. 13, 2016	Radiation (03CH12-HY)



Instrument	Manufacturer	Model No.	Serial No.	Characteristics	Calibration Date	Test Date	Due Date	Remark
Filter	Wainwright	WLKS1200-8S S	SN3	1.2G Low Pass	Oct. 01, 2015	Feb. 17, 2016 ~ Feb. 18, 2016	Sep. 30, 2016	Radiation (03CH12-HY)
Filter	Wainwright	WHK1.5/15G-1 0SS	SN32	1.5G High Pass	Oct. 01, 2015	Feb. 17, 2016 ~ Feb. 18, 2016	Sep. 30, 2016	Radiation (03CH12-HY)
Filter	Microwave	H3G018G1	SN477220	3.0G High Pass	Oct. 01, 2015	Feb. 17, 2016 ~ Feb. 18, 2016	Sep. 30, 2016	Radiation (03CH12-HY)
Notch Filter	Wainwright	WRCG824/849 -40/8SS	SN35	CDMA 850	Oct. 01, 2015	Feb. 17, 2016 ~ Feb. 18, 2016	Sep. 30, 2016	Radiation (03CH12-HY)
Notch Filter	Wainwright	WRCT1850/19 10-40/8SS	SN21	1900	Oct. 01, 2015	Feb. 17, 2016 ~ Feb. 18, 2016	Sep. 30, 2016	Radiation (03CH12-HY)
Test Software	N/A	E3	6.2009-8-24	N/A	N/A	Feb. 17, 2016 ~ Feb. 18, 2016	N/A	Radiation (03CH12-HY)



6 Uncertainty of Evaluation

Uncertainty of Radiated Emission Measurement (30 MHz ~ 1000 MHz)

Measuring Uncertainty for a Level of Confidence of 95% ($U = 2Uc(y)$)	4.90
---	------



Appendix A. Test Results of Conducted Test

Conducted Output Power(Average power)

Conducted Power (*Unit: dBm)						
Band	GSM850			GSM1900		
Channel	128	189	251	512	661	810
Frequency	824.2	836.4	848.8	1850.2	1880.0	1909.8
GSM	32.34	32.35	32.29	29.22	29.32	29.35
GPRS class 8	32.32	32.33	32.27	29.18	29.31	29.33
GPRS class 10	30.13	30.15	30.05	26.08	26.20	26.37
GPRS class 11	29.31	29.31	29.23	25.17	25.28	25.46
GPRS class 12	28.83	28.82	28.75	24.05	24.20	24.38
EGPRS class 8	27.00	27.07	27.08	25.76	25.98	25.90
EGPRS class 10	25.74	25.79	25.77	24.75	24.90	24.91
EGPRS class 11	24.22	24.35	24.28	22.94	23.12	23.16
EGPRS class 12	22.40	22.43	22.43	21.36	21.59	21.59

Conducted Power (*Unit: dBm)						
Band	WCDMA Band V			WCDMA Band II		
Channel	4132	4182	4233	9262	9400	9538
Frequency	826.4	836.4	846.6	1852.4	1880	1907.6
RMC 12.2K	23.30	23.17	23.27	23.53	23.45	23.48
HSDPA Subtest-1	22.21	22.17	22.28	22.45	22.44	22.52
HSDPA Subtest-2	22.22	22.12	22.22	22.46	22.47	22.44
HSDPA Subtest-3	22.73	22.69	22.79	22.93	22.98	22.94
HSDPA Subtest-4	22.75	22.67	22.75	22.90	22.95	22.96
HSUPA Subtest-1	21.22	21.18	21.26	21.49	21.50	21.45
HSUPA Subtest-2	20.25	20.19	20.28	20.46	20.47	20.48
HSUPA Subtest-3	20.21	20.17	20.30	20.39	20.44	20.42
HSUPA Subtest-4	19.80	19.95	20.00	19.93	19.98	19.95
HSUPA Subtest-5	21.24	21.21	21.23	21.46	21.49	21.46



A1. GSM

Peak-to-Average Ratio

Mode	GSM850		Limit: 13dB
Mod.	GSM	EDGE class 8	Result
Lowest CH	0.20	3.28	PASS
Middle CH	0.20	3.16	
Highest CH	0.24	3.12	

Mode	GSM1900		Limit: 13dB
Mod.	GSM	EDGE class 8	Result
Lowest CH	0.20	2.80	PASS
Middle CH	0.20	2.92	
Highest CH	0.24	2.88	

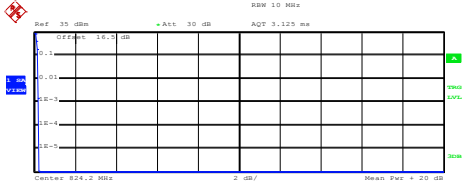
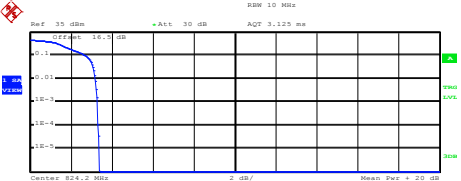
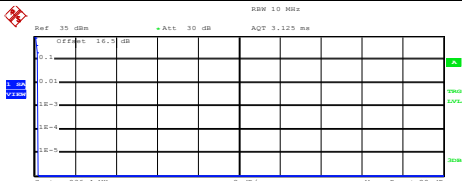
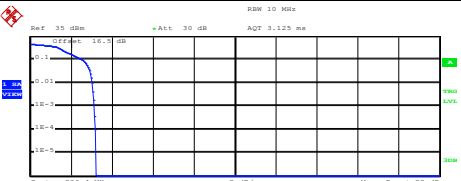
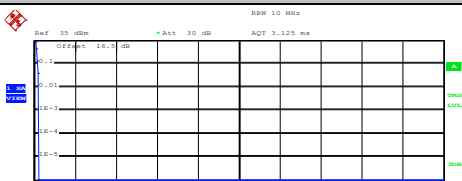
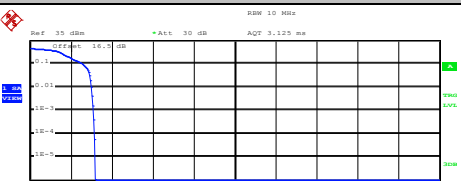

GSM850 (GSM)	GSM850 (EDGE class 8)																												
<p align="center">Lowest Channel</p>  <p>Center: 824.2 MHz 2 dB/</p> <p>Complementary Cumulative Distribution Function (100000 samples) Trace 1</p> <table border="0"> <tr><td>Mean</td><td>31.10 dBm</td></tr> <tr><td>Peak</td><td>31.30 dBm</td></tr> <tr><td>Crest</td><td>0.20 dB</td></tr> </table> <table border="0"> <tr><td>10 %</td><td>0.16 dB</td></tr> <tr><td>1 %</td><td>0.20 dB</td></tr> <tr><td>.1 %</td><td>0.20 dB</td></tr> <tr><td>.01 %</td><td>0.24 dB</td></tr> </table> <p>Date: 25.FEB.2016 10:08:13</p>	Mean	31.10 dBm	Peak	31.30 dBm	Crest	0.20 dB	10 %	0.16 dB	1 %	0.20 dB	.1 %	0.20 dB	.01 %	0.24 dB	<p align="center">Lowest Channel</p>  <p>Center: 824.2 MHz 2 dB/</p> <p>Complementary Cumulative Distribution Function (100000 samples) Trace 1</p> <table border="0"> <tr><td>Mean</td><td>26.94 dBm</td></tr> <tr><td>Peak</td><td>30.31 dBm</td></tr> <tr><td>Crest</td><td>3.37 dB</td></tr> </table> <table border="0"> <tr><td>10 %</td><td>2.72 dB</td></tr> <tr><td>1 %</td><td>3.20 dB</td></tr> <tr><td>.1 %</td><td>3.28 dB</td></tr> <tr><td>.01 %</td><td>3.32 dB</td></tr> </table> <p>Date: 25.FEB.2016 10:24:03</p>	Mean	26.94 dBm	Peak	30.31 dBm	Crest	3.37 dB	10 %	2.72 dB	1 %	3.20 dB	.1 %	3.28 dB	.01 %	3.32 dB
Mean	31.10 dBm																												
Peak	31.30 dBm																												
Crest	0.20 dB																												
10 %	0.16 dB																												
1 %	0.20 dB																												
.1 %	0.20 dB																												
.01 %	0.24 dB																												
Mean	26.94 dBm																												
Peak	30.31 dBm																												
Crest	3.37 dB																												
10 %	2.72 dB																												
1 %	3.20 dB																												
.1 %	3.28 dB																												
.01 %	3.32 dB																												
<p align="center">Middle Channel</p>  <p>Center: 836.4 MHz 2 dB/</p> <p>Complementary Cumulative Distribution Function (100000 samples) Trace 1</p> <table border="0"> <tr><td>Mean</td><td>31.67 dBm</td></tr> <tr><td>Peak</td><td>31.86 dBm</td></tr> <tr><td>Crest</td><td>0.20 dB</td></tr> </table> <table border="0"> <tr><td>10 %</td><td>0.16 dB</td></tr> <tr><td>1 %</td><td>0.20 dB</td></tr> <tr><td>.1 %</td><td>0.20 dB</td></tr> <tr><td>.01 %</td><td>0.20 dB</td></tr> </table> <p>Date: 25.FEB.2016 10:08:32</p>	Mean	31.67 dBm	Peak	31.86 dBm	Crest	0.20 dB	10 %	0.16 dB	1 %	0.20 dB	.1 %	0.20 dB	.01 %	0.20 dB	<p align="center">Middle Channel</p>  <p>Center: 836.4 MHz 2 dB/</p> <p>Complementary Cumulative Distribution Function (100000 samples) Trace 1</p> <table border="0"> <tr><td>Mean</td><td>27.45 dBm</td></tr> <tr><td>Peak</td><td>30.66 dBm</td></tr> <tr><td>Crest</td><td>3.21 dB</td></tr> </table> <table border="0"> <tr><td>10 %</td><td>2.56 dB</td></tr> <tr><td>1 %</td><td>3.04 dB</td></tr> <tr><td>.1 %</td><td>3.16 dB</td></tr> <tr><td>.01 %</td><td>3.20 dB</td></tr> </table> <p>Date: 25.FEB.2016 10:24:18</p>	Mean	27.45 dBm	Peak	30.66 dBm	Crest	3.21 dB	10 %	2.56 dB	1 %	3.04 dB	.1 %	3.16 dB	.01 %	3.20 dB
Mean	31.67 dBm																												
Peak	31.86 dBm																												
Crest	0.20 dB																												
10 %	0.16 dB																												
1 %	0.20 dB																												
.1 %	0.20 dB																												
.01 %	0.20 dB																												
Mean	27.45 dBm																												
Peak	30.66 dBm																												
Crest	3.21 dB																												
10 %	2.56 dB																												
1 %	3.04 dB																												
.1 %	3.16 dB																												
.01 %	3.20 dB																												
<p align="center">Highest Channel</p>  <p>Center: 848.6 MHz 2 dB/</p> <p>Complementary Cumulative Distribution Function (100000 samples) Trace 1</p> <table border="0"> <tr><td>Mean</td><td>32.42 dBm</td></tr> <tr><td>Peak</td><td>32.64 dBm</td></tr> <tr><td>Crest</td><td>0.22 dB</td></tr> </table> <table border="0"> <tr><td>10 %</td><td>0.16 dB</td></tr> <tr><td>1 %</td><td>0.24 dB</td></tr> <tr><td>.1 %</td><td>0.24 dB</td></tr> <tr><td>.01 %</td><td>0.24 dB</td></tr> </table> <p>Date: 25.FEB.2016 10:08:53</p>	Mean	32.42 dBm	Peak	32.64 dBm	Crest	0.22 dB	10 %	0.16 dB	1 %	0.24 dB	.1 %	0.24 dB	.01 %	0.24 dB	<p align="center">Highest Channel</p>  <p>Center: 848.6 MHz 2 dB/</p> <p>Complementary Cumulative Distribution Function (100000 samples) Trace 1</p> <table border="0"> <tr><td>Mean</td><td>27.22 dBm</td></tr> <tr><td>Peak</td><td>30.38 dBm</td></tr> <tr><td>Crest</td><td>3.16 dB</td></tr> </table> <table border="0"> <tr><td>10 %</td><td>2.56 dB</td></tr> <tr><td>1 %</td><td>3.00 dB</td></tr> <tr><td>.1 %</td><td>3.12 dB</td></tr> <tr><td>.01 %</td><td>3.16 dB</td></tr> </table> <p>Date: 25.FEB.2016 10:24:39</p>	Mean	27.22 dBm	Peak	30.38 dBm	Crest	3.16 dB	10 %	2.56 dB	1 %	3.00 dB	.1 %	3.12 dB	.01 %	3.16 dB
Mean	32.42 dBm																												
Peak	32.64 dBm																												
Crest	0.22 dB																												
10 %	0.16 dB																												
1 %	0.24 dB																												
.1 %	0.24 dB																												
.01 %	0.24 dB																												
Mean	27.22 dBm																												
Peak	30.38 dBm																												
Crest	3.16 dB																												
10 %	2.56 dB																												
1 %	3.00 dB																												
.1 %	3.12 dB																												
.01 %	3.16 dB																												

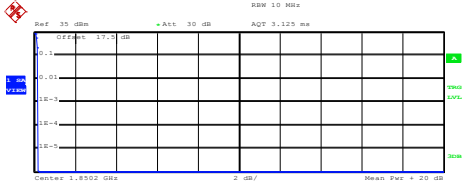
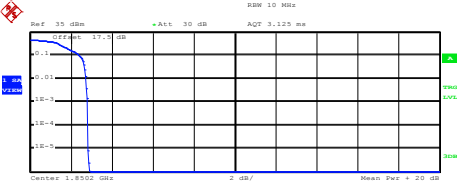
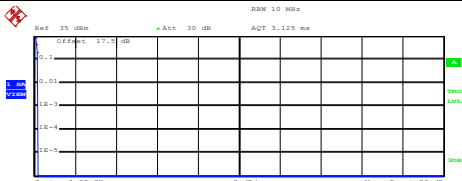
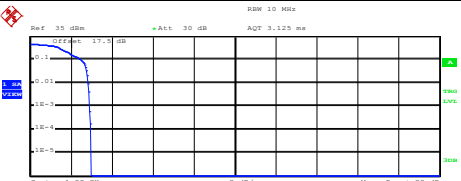
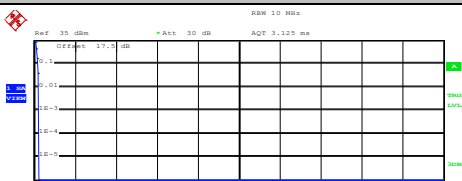
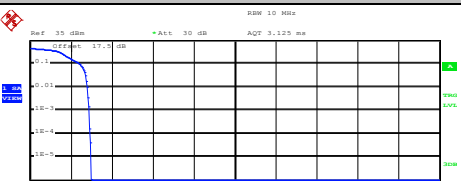

GSM1900 (GSM)	GSM1900 (EDGE class 8)
<p align="center">Lowest Channel</p>  <p align="center">Complementary Cumulative Distribution Function (100000 samples) Trace 1</p> <p>Mean 30.06 dBm Peak 30.24 dBm Crest 0.18 dB</p> <p>10 % 0.20 dB 1 % 0.20 dB .1 % 0.20 dB .01 % 0.20 dB</p> <p>Date: 25.FEB.2016 11:10:15</p>	<p align="center">Lowest Channel</p>  <p align="center">Complementary Cumulative Distribution Function (100000 samples) Trace 1</p> <p>Mean 26.50 dBm Peak 29.39 dBm Crest 2.89 dB</p> <p>10 % 2.44 dB 1 % 2.72 dB .1 % 2.80 dB .01 % 2.84 dB</p> <p>Date: 25.FEB.2016 11:40:12</p>
<p align="center">Middle Channel</p>  <p align="center">Complementary Cumulative Distribution Function (100000 samples) Trace 1</p> <p>Mean 28.71 dBm Peak 28.90 dBm Crest 0.20 dB</p> <p>10 % 0.20 dB 1 % 0.20 dB .1 % 0.20 dB .01 % 0.20 dB</p> <p>Date: 25.FEB.2016 11:10:34</p>	<p align="center">Middle Channel</p>  <p align="center">Complementary Cumulative Distribution Function (100000 samples) Trace 1</p> <p>Mean 24.94 dBm Peak 27.91 dBm Crest 2.97 dB</p> <p>10 % 2.48 dB 1 % 2.84 dB .1 % 2.92 dB .01 % 2.96 dB</p> <p>Date: 25.FEB.2016 11:40:31</p>
<p align="center">Highest Channel</p>  <p align="center">Complementary Cumulative Distribution Function (100000 samples) Trace 1</p> <p>Mean 28.48 dBm Peak 28.69 dBm Crest 0.21 dB</p> <p>10 % 0.20 dB 1 % 0.24 dB .1 % 0.24 dB .01 % 0.24 dB</p> <p>Date: 25.FEB.2016 11:10:55</p>	<p align="center">Highest Channel</p>  <p align="center">Complementary Cumulative Distribution Function (100000 samples) Trace 1</p> <p>Mean 25.30 dBm Peak 28.27 dBm Crest 2.97 dB</p> <p>10 % 2.44 dB 1 % 2.80 dB .1 % 2.88 dB .01 % 2.96 dB</p> <p>Date: 25.FEB.2016 11:40:54</p>



26dB Bandwidth

Mode	GSM850	
Mod.	GSM	EDGE class 8
Lowest CH	0.294	0.299
Middle CH	0.316	0.305
Highest CH	0.312	0.302

Mode	GSM1900	
Mod.	GSM	EDGE class 8
Lowest CH	0.307	0.304
Middle CH	0.315	0.315
Highest CH	0.310	0.314



GSM850 (GSM)

Lowest Channel

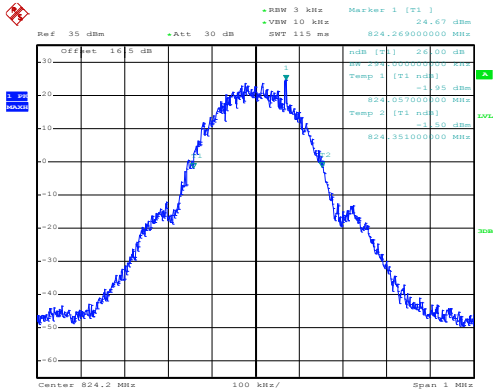

Date: 25.FEB.2016 09:55:40

GSM850 (EDGE class 8)

Lowest Channel

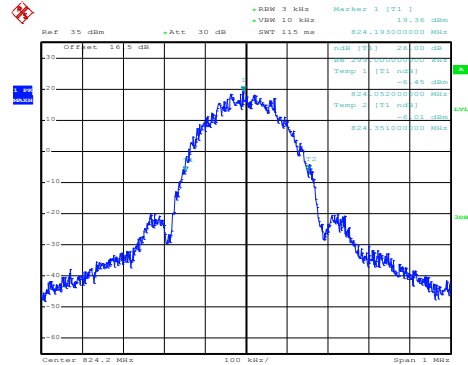

Date: 25.FEB.2016 10:15:40

Middle Channel

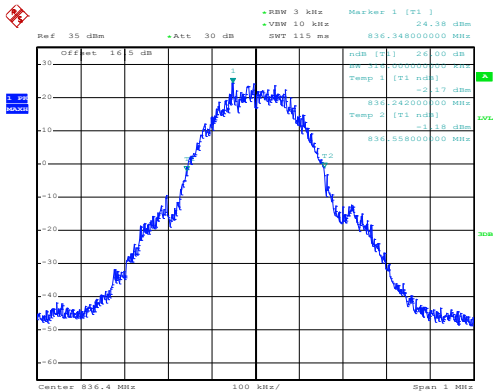

Date: 25.FEB.2016 09:56:52

Middle Channel

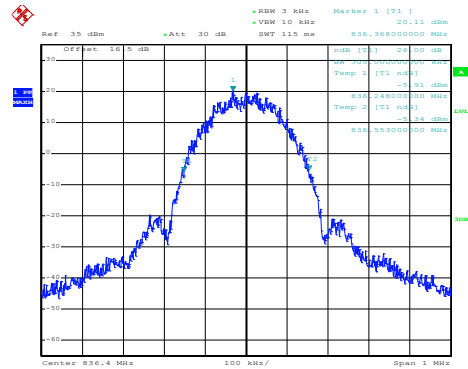

Date: 25.FEB.2016 10:16:22

Highest Channel

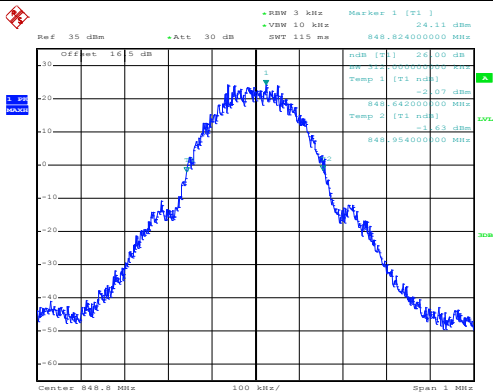

Date: 25.FEB.2016 09:57:39

Highest Channel

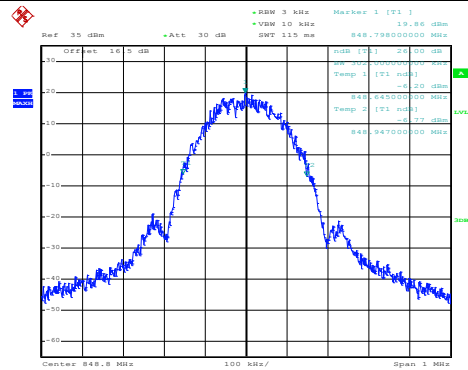

Date: 25.FEB.2016 10:16:59



GSM1900 (GSM)

Lowest Channel

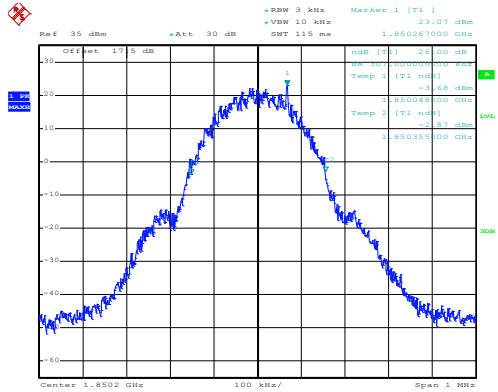

Date: 25.FEB.2016 10:58:26

GSM1900 (EDGE class 8)

Lowest Channel

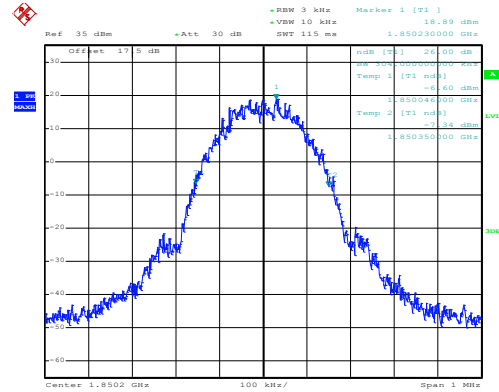

Date: 25.FEB.2016 11:25:58

Middle Channel

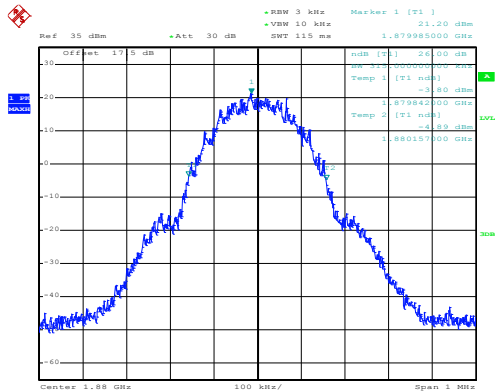

Date: 25.FEB.2016 10:59:09

Middle Channel

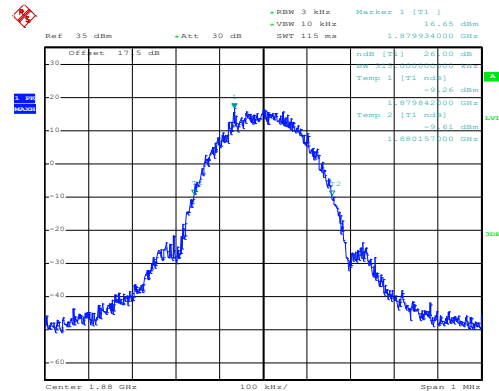

Date: 25.FEB.2016 11:27:16

Highest Channel

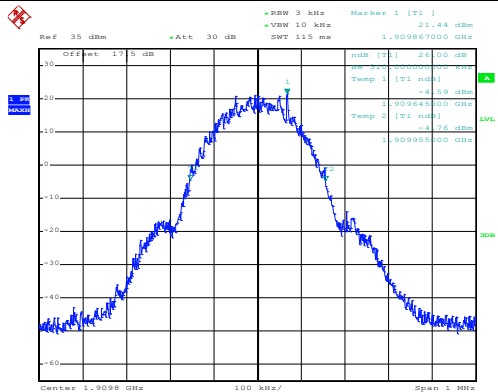

Date: 25.FEB.2016 11:00:10

Highest Channel

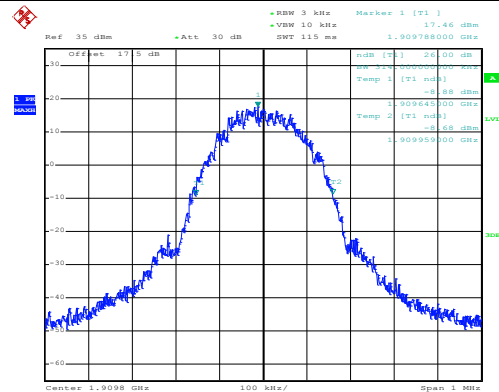

Date: 25.FEB.2016 11:28:55



Occupied Bandwidth

Mode	GSM850	
Mod.	GSM	EDGE class 8
Lowest CH	0.245	0.249
Middle CH	0.244	0.246
Highest CH	0.246	0.248

Mode	GSM1900	
Mod.	GSM	EDGE class 8
Lowest CH	0.247	0.249
Middle CH	0.243	0.253
Highest CH	0.246	0.249



GSM850 (GSM)

Lowest Channel

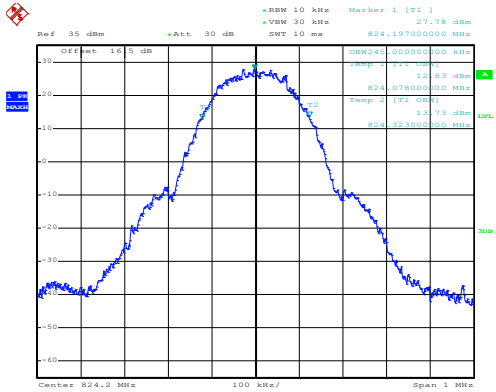

Date: 25.FEB.2016 09:58:52

GSM850 (EDGE class 8)

Lowest Channel

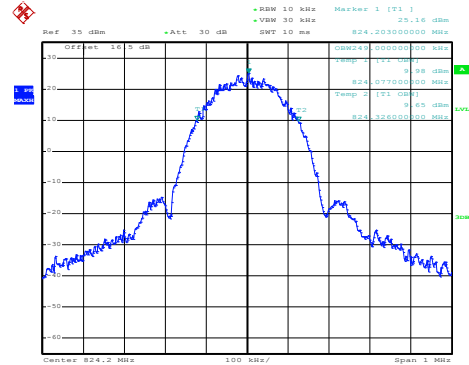

Date: 25.FEB.2016 10:18:10

Middle Channel

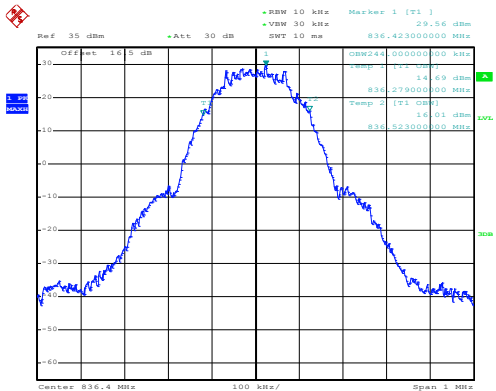

Date: 25.FEB.2016 10:00:26

Middle Channel

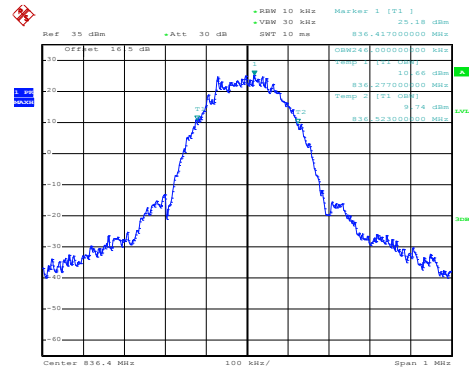

Date: 25.FEB.2016 10:18:54

Highest Channel

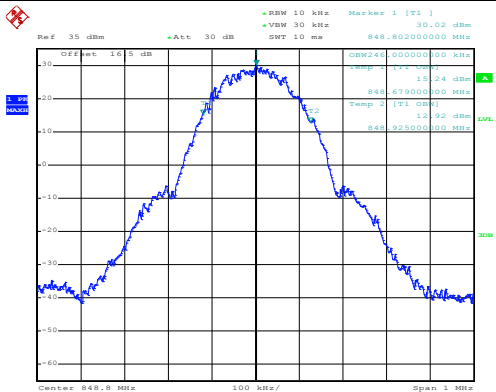

Date: 25.FEB.2016 10:01:05

Highest Channel

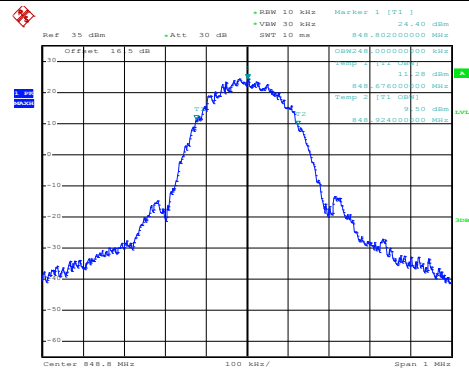

Date: 25.FEB.2016 10:19:40



GSM1900 (GSM)

Lowest Channel

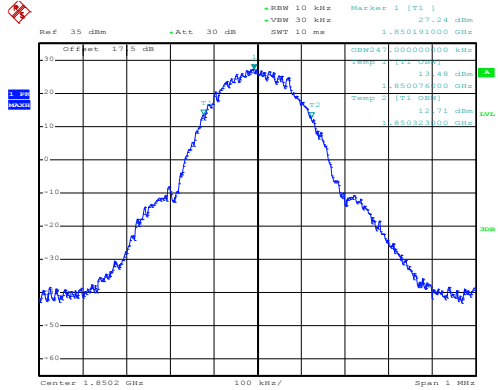

Date: 25.FEB.2016 11:02:15

GSM1900 (EDGE class 8)

Lowest Channel

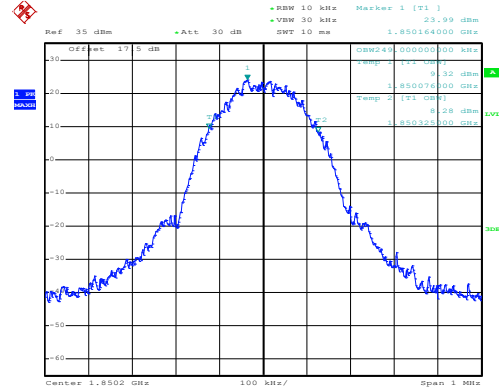

Date: 25.FEB.2016 11:31:31

Middle Channel

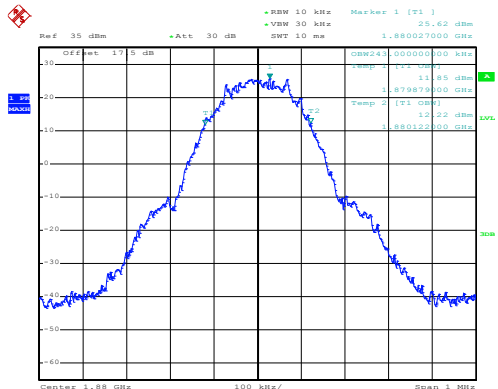

Date: 25.FEB.2016 11:02:49

Middle Channel

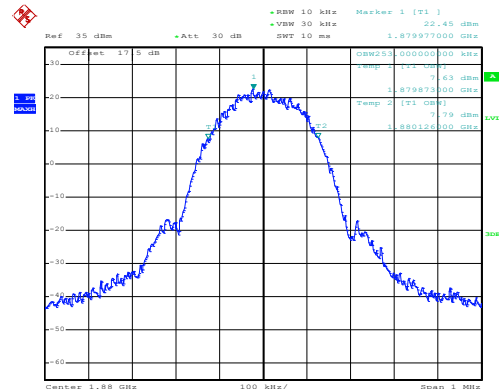

Date: 25.FEB.2016 11:32:29

Highest Channel

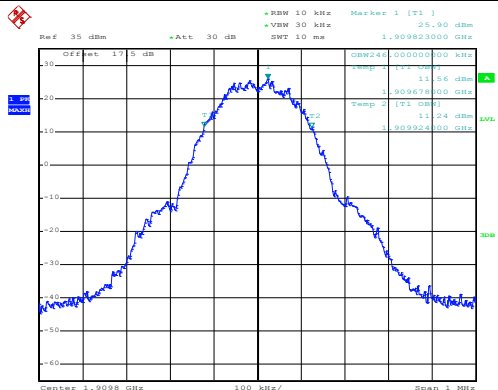

Date: 25.FEB.2016 11:03:28

Highest Channel

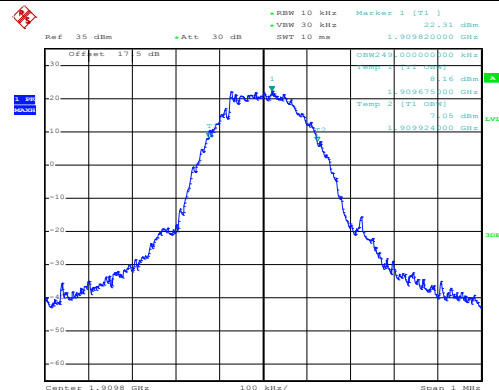

Date: 25.FEB.2016 11:33:11



Conducted Band Edge



GSM850 (GSM)

Lowest Band Edge

Highest Band Edge

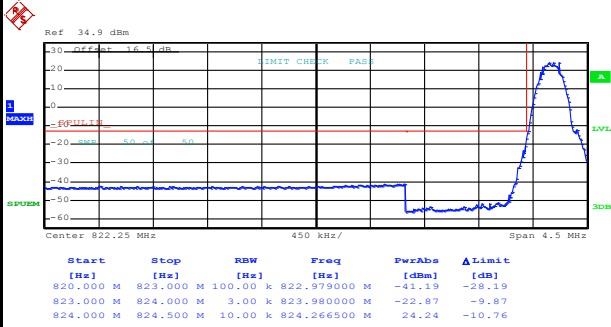

Date: 25.FEB.2016 10:03:14

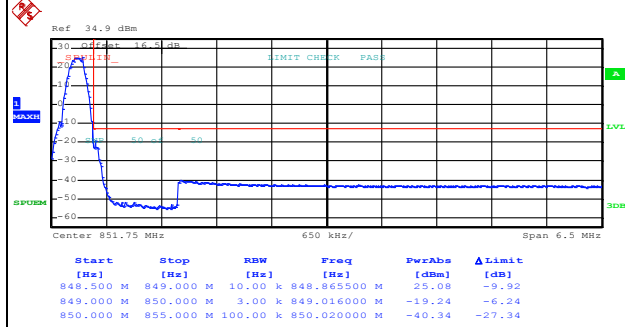

Date: 25.FEB.2016 10:04:47

GSM850 (EDGE class 8)

Lowest Band Edge

Highest Band Edge

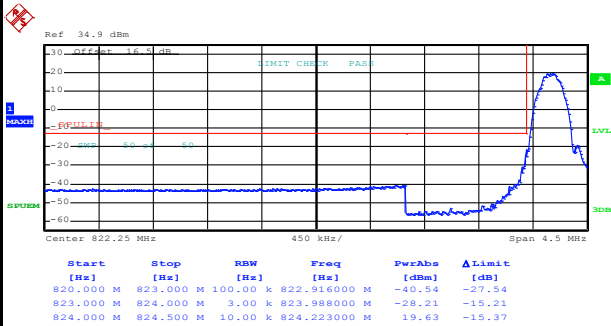

Date: 25.FEB.2016 10:26:16

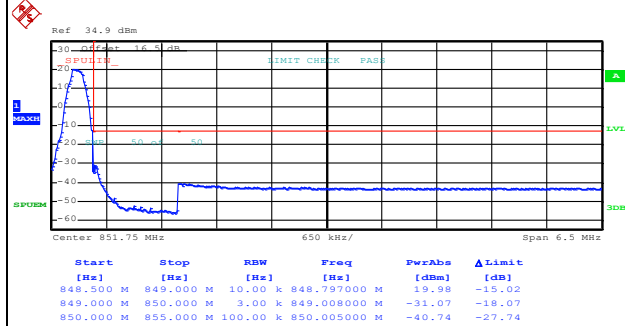

Date: 25.FEB.2016 10:31:48



GSM1900 (GSM)

Lowest Band Edge

Highest Band Edge

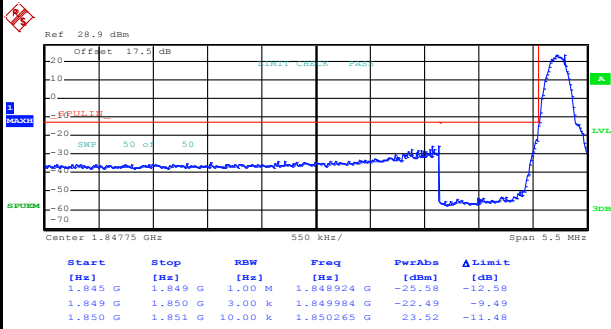

Date: 25.FEB.2016 11:12:36

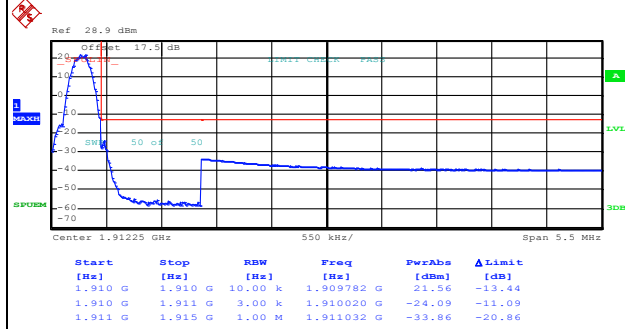

Date: 25.FEB.2016 11:14:11

GSM1900 (EDGE class 8)

Lowest Band Edge

Highest Band Edge

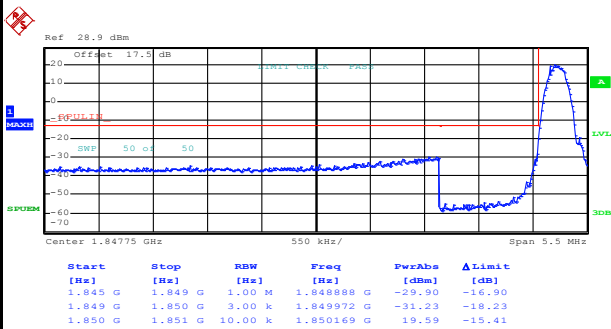

Date: 25.FEB.2016 11:42:41

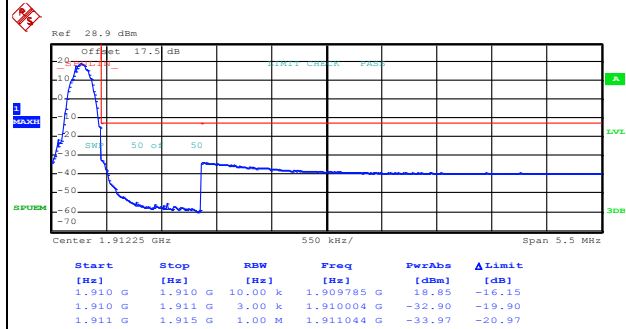

Date: 25.FEB.2016 11:46:05



Conducted Spurious Emission

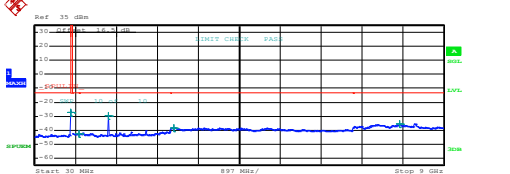
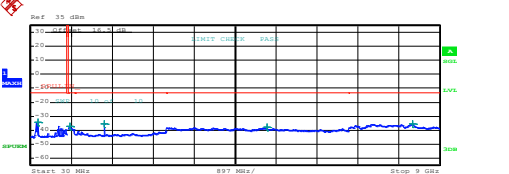
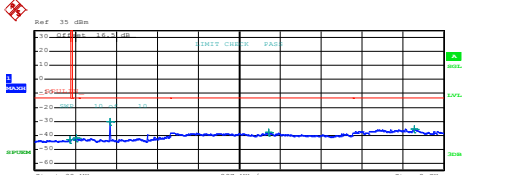
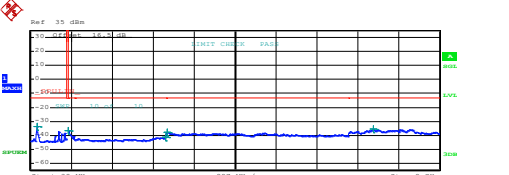
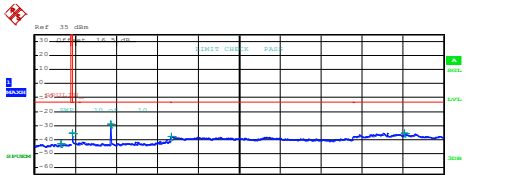
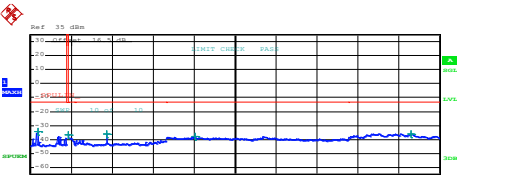

GSM850 (GSM)	GSM850 (EDGE class 8)																																																																								
Lowest Channel	Lowest Channel																																																																								
 <table border="1" data-bbox="239 622 686 705"> <thead> <tr> <th>Start [Hz]</th> <th>Stop [Hz]</th> <th>RBW [Hz]</th> <th>Freq [Hz]</th> <th>PwrAve [dBm]</th> <th>ΔLimit [dB]</th> </tr> </thead> <tbody> <tr> <td>30,000 M</td> <td>820,000 M</td> <td>1,000 M</td> <td>819,402500 M</td> <td>-27.41</td> <td>-14.41</td> </tr> <tr> <td>855,000 M</td> <td>1,000 G</td> <td>1,000 M</td> <td>992,351250 M</td> <td>-42.33</td> <td>-29.33</td> </tr> <tr> <td>1,000 G</td> <td>3,000 G</td> <td>1,000 M</td> <td>1,648500 G</td> <td>-29.81</td> <td>-26.81</td> </tr> <tr> <td>3,000 G</td> <td>7,000 G</td> <td>1,000 M</td> <td>3,086000 G</td> <td>-38.33</td> <td>-25.33</td> </tr> <tr> <td>7,000 G</td> <td>9,000 G</td> <td>1,000 M</td> <td>8,031500 G</td> <td>-35.32</td> <td>-22.32</td> </tr> </tbody> </table> <p>Date: 25.FEB.2016 10:06:07</p>	Start [Hz]	Stop [Hz]	RBW [Hz]	Freq [Hz]	PwrAve [dBm]	ΔLimit [dB]	30,000 M	820,000 M	1,000 M	819,402500 M	-27.41	-14.41	855,000 M	1,000 G	1,000 M	992,351250 M	-42.33	-29.33	1,000 G	3,000 G	1,000 M	1,648500 G	-29.81	-26.81	3,000 G	7,000 G	1,000 M	3,086000 G	-38.33	-25.33	7,000 G	9,000 G	1,000 M	8,031500 G	-35.32	-22.32	 <table border="1" data-bbox="893 622 1340 705"> <thead> <tr> <th>Start [Hz]</th> <th>Stop [Hz]</th> <th>RBW [Hz]</th> <th>Freq [Hz]</th> <th>PwrAve [dBm]</th> <th>ΔLimit [dB]</th> </tr> </thead> <tbody> <tr> <td>30,000 M</td> <td>820,000 M</td> <td>1,000 M</td> <td>189,580000 M</td> <td>-24.50</td> <td>-21.50</td> </tr> <tr> <td>855,000 M</td> <td>1,000 G</td> <td>1,000 M</td> <td>891,322503 M</td> <td>-37.06</td> <td>-24.06</td> </tr> <tr> <td>1,000 G</td> <td>3,000 G</td> <td>1,000 M</td> <td>1,648500 G</td> <td>-29.85</td> <td>-22.85</td> </tr> <tr> <td>3,000 G</td> <td>7,000 G</td> <td>1,000 M</td> <td>5,214000 G</td> <td>-38.04</td> <td>-25.04</td> </tr> <tr> <td>7,000 G</td> <td>9,000 G</td> <td>1,000 M</td> <td>8,413500 G</td> <td>-35.66</td> <td>-22.66</td> </tr> </tbody> </table> <p>Date: 25.FEB.2016 10:21:14</p>	Start [Hz]	Stop [Hz]	RBW [Hz]	Freq [Hz]	PwrAve [dBm]	ΔLimit [dB]	30,000 M	820,000 M	1,000 M	189,580000 M	-24.50	-21.50	855,000 M	1,000 G	1,000 M	891,322503 M	-37.06	-24.06	1,000 G	3,000 G	1,000 M	1,648500 G	-29.85	-22.85	3,000 G	7,000 G	1,000 M	5,214000 G	-38.04	-25.04	7,000 G	9,000 G	1,000 M	8,413500 G	-35.66	-22.66
Start [Hz]	Stop [Hz]	RBW [Hz]	Freq [Hz]	PwrAve [dBm]	ΔLimit [dB]																																																																				
30,000 M	820,000 M	1,000 M	819,402500 M	-27.41	-14.41																																																																				
855,000 M	1,000 G	1,000 M	992,351250 M	-42.33	-29.33																																																																				
1,000 G	3,000 G	1,000 M	1,648500 G	-29.81	-26.81																																																																				
3,000 G	7,000 G	1,000 M	3,086000 G	-38.33	-25.33																																																																				
7,000 G	9,000 G	1,000 M	8,031500 G	-35.32	-22.32																																																																				
Start [Hz]	Stop [Hz]	RBW [Hz]	Freq [Hz]	PwrAve [dBm]	ΔLimit [dB]																																																																				
30,000 M	820,000 M	1,000 M	189,580000 M	-24.50	-21.50																																																																				
855,000 M	1,000 G	1,000 M	891,322503 M	-37.06	-24.06																																																																				
1,000 G	3,000 G	1,000 M	1,648500 G	-29.85	-22.85																																																																				
3,000 G	7,000 G	1,000 M	5,214000 G	-38.04	-25.04																																																																				
7,000 G	9,000 G	1,000 M	8,413500 G	-35.66	-22.66																																																																				
Middle Channel	Middle Channel																																																																								
 <table border="1" data-bbox="239 1137 686 1220"> <thead> <tr> <th>Start [Hz]</th> <th>Stop [Hz]</th> <th>RBW [Hz]</th> <th>Freq [Hz]</th> <th>PwrAve [dBm]</th> <th>ΔLimit [dB]</th> </tr> </thead> <tbody> <tr> <td>30,000 M</td> <td>820,000 M</td> <td>1,000 M</td> <td>804,202500 M</td> <td>-43.19</td> <td>-30.19</td> </tr> <tr> <td>855,000 M</td> <td>1,000 G</td> <td>1,000 M</td> <td>947,328756 M</td> <td>-42.98</td> <td>-28.98</td> </tr> <tr> <td>1,000 G</td> <td>3,000 G</td> <td>1,000 M</td> <td>1,673000 G</td> <td>-30.07</td> <td>-17.07</td> </tr> <tr> <td>3,000 G</td> <td>7,000 G</td> <td>1,000 M</td> <td>3,153000 G</td> <td>-37.94</td> <td>-24.94</td> </tr> <tr> <td>7,000 G</td> <td>9,000 G</td> <td>1,000 M</td> <td>8,160000 G</td> <td>-35.35</td> <td>-22.35</td> </tr> </tbody> </table> <p>Date: 25.FEB.2016 10:06:57</p>	Start [Hz]	Stop [Hz]	RBW [Hz]	Freq [Hz]	PwrAve [dBm]	ΔLimit [dB]	30,000 M	820,000 M	1,000 M	804,202500 M	-43.19	-30.19	855,000 M	1,000 G	1,000 M	947,328756 M	-42.98	-28.98	1,000 G	3,000 G	1,000 M	1,673000 G	-30.07	-17.07	3,000 G	7,000 G	1,000 M	3,153000 G	-37.94	-24.94	7,000 G	9,000 G	1,000 M	8,160000 G	-35.35	-22.35	 <table border="1" data-bbox="893 1137 1340 1220"> <thead> <tr> <th>Start [Hz]</th> <th>Stop [Hz]</th> <th>RBW [Hz]</th> <th>Freq [Hz]</th> <th>PwrAve [dBm]</th> <th>ΔLimit [dB]</th> </tr> </thead> <tbody> <tr> <td>30,000 M</td> <td>820,000 M</td> <td>1,000 M</td> <td>100,480000 M</td> <td>-37.78</td> <td>-20.78</td> </tr> <tr> <td>855,000 M</td> <td>1,000 G</td> <td>1,000 M</td> <td>861,923750 M</td> <td>-36.58</td> <td>-23.58</td> </tr> <tr> <td>1,000 G</td> <td>3,000 G</td> <td>1,000 M</td> <td>2,989500 G</td> <td>-41.15</td> <td>-28.15</td> </tr> <tr> <td>3,000 G</td> <td>7,000 G</td> <td>1,000 M</td> <td>3,019000 G</td> <td>-37.83</td> <td>-24.83</td> </tr> <tr> <td>7,000 G</td> <td>9,000 G</td> <td>1,000 M</td> <td>7,549500 G</td> <td>-35.43</td> <td>-22.43</td> </tr> </tbody> </table> <p>Date: 25.FEB.2016 10:22:05</p>	Start [Hz]	Stop [Hz]	RBW [Hz]	Freq [Hz]	PwrAve [dBm]	ΔLimit [dB]	30,000 M	820,000 M	1,000 M	100,480000 M	-37.78	-20.78	855,000 M	1,000 G	1,000 M	861,923750 M	-36.58	-23.58	1,000 G	3,000 G	1,000 M	2,989500 G	-41.15	-28.15	3,000 G	7,000 G	1,000 M	3,019000 G	-37.83	-24.83	7,000 G	9,000 G	1,000 M	7,549500 G	-35.43	-22.43
Start [Hz]	Stop [Hz]	RBW [Hz]	Freq [Hz]	PwrAve [dBm]	ΔLimit [dB]																																																																				
30,000 M	820,000 M	1,000 M	804,202500 M	-43.19	-30.19																																																																				
855,000 M	1,000 G	1,000 M	947,328756 M	-42.98	-28.98																																																																				
1,000 G	3,000 G	1,000 M	1,673000 G	-30.07	-17.07																																																																				
3,000 G	7,000 G	1,000 M	3,153000 G	-37.94	-24.94																																																																				
7,000 G	9,000 G	1,000 M	8,160000 G	-35.35	-22.35																																																																				
Start [Hz]	Stop [Hz]	RBW [Hz]	Freq [Hz]	PwrAve [dBm]	ΔLimit [dB]																																																																				
30,000 M	820,000 M	1,000 M	100,480000 M	-37.78	-20.78																																																																				
855,000 M	1,000 G	1,000 M	861,923750 M	-36.58	-23.58																																																																				
1,000 G	3,000 G	1,000 M	2,989500 G	-41.15	-28.15																																																																				
3,000 G	7,000 G	1,000 M	3,019000 G	-37.83	-24.83																																																																				
7,000 G	9,000 G	1,000 M	7,549500 G	-35.43	-22.43																																																																				
Highest Channel	Highest Channel																																																																								
 <table border="1" data-bbox="239 1653 686 1736"> <thead> <tr> <th>Start [Hz]</th> <th>Stop [Hz]</th> <th>RBW [Hz]</th> <th>Freq [Hz]</th> <th>PwrAve [dBm]</th> <th>ΔLimit [dB]</th> </tr> </thead> <tbody> <tr> <td>30,000 M</td> <td>820,000 M</td> <td>1,000 M</td> <td>608,470000 M</td> <td>-43.03</td> <td>-30.03</td> </tr> <tr> <td>855,000 M</td> <td>1,000 G</td> <td>1,000 M</td> <td>856,072500 M</td> <td>-35.76</td> <td>-22.76</td> </tr> <tr> <td>1,000 G</td> <td>3,000 G</td> <td>1,000 M</td> <td>1,697500 G</td> <td>-39.01</td> <td>-26.01</td> </tr> <tr> <td>3,000 G</td> <td>7,000 G</td> <td>1,000 M</td> <td>3,023000 G</td> <td>-38.09</td> <td>-25.09</td> </tr> <tr> <td>7,000 G</td> <td>9,000 G</td> <td>1,000 M</td> <td>8,144500 G</td> <td>-35.34</td> <td>-22.34</td> </tr> </tbody> </table> <p>Date: 25.FEB.2016 10:07:48</p>	Start [Hz]	Stop [Hz]	RBW [Hz]	Freq [Hz]	PwrAve [dBm]	ΔLimit [dB]	30,000 M	820,000 M	1,000 M	608,470000 M	-43.03	-30.03	855,000 M	1,000 G	1,000 M	856,072500 M	-35.76	-22.76	1,000 G	3,000 G	1,000 M	1,697500 G	-39.01	-26.01	3,000 G	7,000 G	1,000 M	3,023000 G	-38.09	-25.09	7,000 G	9,000 G	1,000 M	8,144500 G	-35.34	-22.34	 <table border="1" data-bbox="893 1653 1340 1736"> <thead> <tr> <th>Start [Hz]</th> <th>Stop [Hz]</th> <th>RBW [Hz]</th> <th>Freq [Hz]</th> <th>PwrAve [dBm]</th> <th>ΔLimit [dB]</th> </tr> </thead> <tbody> <tr> <td>30,000 M</td> <td>820,000 M</td> <td>1,000 M</td> <td>190,580000 M</td> <td>-24.13</td> <td>-21.13</td> </tr> <tr> <td>855,000 M</td> <td>1,000 G</td> <td>1,000 M</td> <td>856,395000 M</td> <td>-36.92</td> <td>-23.92</td> </tr> <tr> <td>1,000 G</td> <td>3,000 G</td> <td>1,000 M</td> <td>1,697500 G</td> <td>-36.00</td> <td>-23.00</td> </tr> <tr> <td>3,000 G</td> <td>7,000 G</td> <td>1,000 M</td> <td>3,627000 G</td> <td>-37.87</td> <td>-24.87</td> </tr> <tr> <td>7,000 G</td> <td>9,000 G</td> <td>1,000 M</td> <td>8,371000 G</td> <td>-35.81</td> <td>-22.81</td> </tr> </tbody> </table> <p>Date: 25.FEB.2016 10:22:59</p>	Start [Hz]	Stop [Hz]	RBW [Hz]	Freq [Hz]	PwrAve [dBm]	ΔLimit [dB]	30,000 M	820,000 M	1,000 M	190,580000 M	-24.13	-21.13	855,000 M	1,000 G	1,000 M	856,395000 M	-36.92	-23.92	1,000 G	3,000 G	1,000 M	1,697500 G	-36.00	-23.00	3,000 G	7,000 G	1,000 M	3,627000 G	-37.87	-24.87	7,000 G	9,000 G	1,000 M	8,371000 G	-35.81	-22.81
Start [Hz]	Stop [Hz]	RBW [Hz]	Freq [Hz]	PwrAve [dBm]	ΔLimit [dB]																																																																				
30,000 M	820,000 M	1,000 M	608,470000 M	-43.03	-30.03																																																																				
855,000 M	1,000 G	1,000 M	856,072500 M	-35.76	-22.76																																																																				
1,000 G	3,000 G	1,000 M	1,697500 G	-39.01	-26.01																																																																				
3,000 G	7,000 G	1,000 M	3,023000 G	-38.09	-25.09																																																																				
7,000 G	9,000 G	1,000 M	8,144500 G	-35.34	-22.34																																																																				
Start [Hz]	Stop [Hz]	RBW [Hz]	Freq [Hz]	PwrAve [dBm]	ΔLimit [dB]																																																																				
30,000 M	820,000 M	1,000 M	190,580000 M	-24.13	-21.13																																																																				
855,000 M	1,000 G	1,000 M	856,395000 M	-36.92	-23.92																																																																				
1,000 G	3,000 G	1,000 M	1,697500 G	-36.00	-23.00																																																																				
3,000 G	7,000 G	1,000 M	3,627000 G	-37.87	-24.87																																																																				
7,000 G	9,000 G	1,000 M	8,371000 G	-35.81	-22.81																																																																				

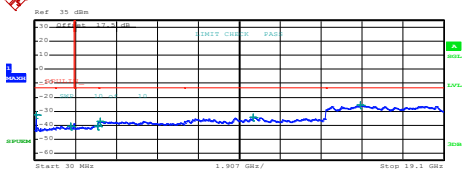
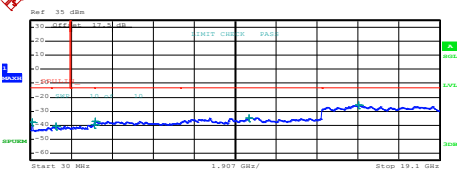
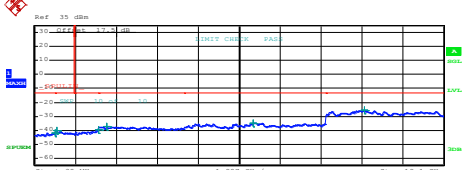
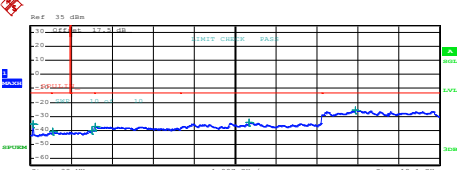
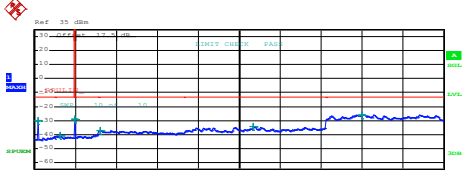
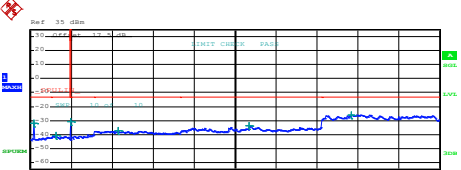

GSM1900 (GSM)	GSM1900 (EDGE class 8)																																																																																																
Lowest Channel	Lowest Channel																																																																																																
 <table border="1" data-bbox="239 616 638 716"> <thead> <tr> <th>Start</th> <th>Stop</th> <th>RBW</th> <th>Freq</th> <th>PwrAve</th> <th>ΔLimit</th> </tr> <tr> <th>[Hz]</th> <th>[Hz]</th> <th>[Hz]</th> <th>[Hz]</th> <th>[dBm]</th> <th>[dB]</th> </tr> </thead> <tbody> <tr> <td>30,000 M</td> <td>1,000 G</td> <td>1,000 M</td> <td>111,985000 M</td> <td>-32.43</td> <td>-19.49</td> </tr> <tr> <td>1,000 G</td> <td>1,845 G</td> <td>1,000 M</td> <td>1,703291 G</td> <td>-40.85</td> <td>-27.85</td> </tr> <tr> <td>1,845 G</td> <td>3,000 G</td> <td>1,000 M</td> <td>2,989276 G</td> <td>-40.45</td> <td>-27.43</td> </tr> <tr> <td>3,000 G</td> <td>7,000 G</td> <td>1,000 M</td> <td>3,094000 G</td> <td>-37.30</td> <td>-24.30</td> </tr> <tr> <td>7,000 G</td> <td>13,600 G</td> <td>1,000 M</td> <td>10,227400 G</td> <td>-34.04</td> <td>-21.04</td> </tr> <tr> <td>13,600 G</td> <td>19,100 G</td> <td>1,000 M</td> <td>15,221125 G</td> <td>-29.72</td> <td>-12.72</td> </tr> </tbody> </table> <p>Date: 25.FEB.2016 11:05:14</p>	Start	Stop	RBW	Freq	PwrAve	ΔLimit	[Hz]	[Hz]	[Hz]	[Hz]	[dBm]	[dB]	30,000 M	1,000 G	1,000 M	111,985000 M	-32.43	-19.49	1,000 G	1,845 G	1,000 M	1,703291 G	-40.85	-27.85	1,845 G	3,000 G	1,000 M	2,989276 G	-40.45	-27.43	3,000 G	7,000 G	1,000 M	3,094000 G	-37.30	-24.30	7,000 G	13,600 G	1,000 M	10,227400 G	-34.04	-21.04	13,600 G	19,100 G	1,000 M	15,221125 G	-29.72	-12.72	 <table border="1" data-bbox="893 616 1292 716"> <thead> <tr> <th>Start</th> <th>Stop</th> <th>RBW</th> <th>Freq</th> <th>PwrAve</th> <th>ΔLimit</th> </tr> <tr> <th>[Hz]</th> <th>[Hz]</th> <th>[Hz]</th> <th>[Hz]</th> <th>[dBm]</th> <th>[dB]</th> </tr> </thead> <tbody> <tr> <td>30,000 M</td> <td>1,000 G</td> <td>1,000 M</td> <td>111,985000 M</td> <td>-37.72</td> <td>-24.72</td> </tr> <tr> <td>1,000 G</td> <td>1,845 G</td> <td>1,000 M</td> <td>1,198786 G</td> <td>-40.48</td> <td>-27.48</td> </tr> <tr> <td>1,845 G</td> <td>3,000 G</td> <td>1,000 M</td> <td>2,989276 G</td> <td>-39.67</td> <td>-26.67</td> </tr> <tr> <td>3,000 G</td> <td>7,000 G</td> <td>1,000 M</td> <td>3,037000 G</td> <td>-37.20</td> <td>-24.20</td> </tr> <tr> <td>7,000 G</td> <td>13,600 G</td> <td>1,000 M</td> <td>10,210075 G</td> <td>-34.62</td> <td>-21.62</td> </tr> <tr> <td>13,600 G</td> <td>19,100 G</td> <td>1,000 M</td> <td>15,327000 G</td> <td>-29.62</td> <td>-12.62</td> </tr> </tbody> </table> <p>Date: 25.FEB.2016 11:36:51</p>	Start	Stop	RBW	Freq	PwrAve	ΔLimit	[Hz]	[Hz]	[Hz]	[Hz]	[dBm]	[dB]	30,000 M	1,000 G	1,000 M	111,985000 M	-37.72	-24.72	1,000 G	1,845 G	1,000 M	1,198786 G	-40.48	-27.48	1,845 G	3,000 G	1,000 M	2,989276 G	-39.67	-26.67	3,000 G	7,000 G	1,000 M	3,037000 G	-37.20	-24.20	7,000 G	13,600 G	1,000 M	10,210075 G	-34.62	-21.62	13,600 G	19,100 G	1,000 M	15,327000 G	-29.62	-12.62
Start	Stop	RBW	Freq	PwrAve	ΔLimit																																																																																												
[Hz]	[Hz]	[Hz]	[Hz]	[dBm]	[dB]																																																																																												
30,000 M	1,000 G	1,000 M	111,985000 M	-32.43	-19.49																																																																																												
1,000 G	1,845 G	1,000 M	1,703291 G	-40.85	-27.85																																																																																												
1,845 G	3,000 G	1,000 M	2,989276 G	-40.45	-27.43																																																																																												
3,000 G	7,000 G	1,000 M	3,094000 G	-37.30	-24.30																																																																																												
7,000 G	13,600 G	1,000 M	10,227400 G	-34.04	-21.04																																																																																												
13,600 G	19,100 G	1,000 M	15,221125 G	-29.72	-12.72																																																																																												
Start	Stop	RBW	Freq	PwrAve	ΔLimit																																																																																												
[Hz]	[Hz]	[Hz]	[Hz]	[dBm]	[dB]																																																																																												
30,000 M	1,000 G	1,000 M	111,985000 M	-37.72	-24.72																																																																																												
1,000 G	1,845 G	1,000 M	1,198786 G	-40.48	-27.48																																																																																												
1,845 G	3,000 G	1,000 M	2,989276 G	-39.67	-26.67																																																																																												
3,000 G	7,000 G	1,000 M	3,037000 G	-37.20	-24.20																																																																																												
7,000 G	13,600 G	1,000 M	10,210075 G	-34.62	-21.62																																																																																												
13,600 G	19,100 G	1,000 M	15,327000 G	-29.62	-12.62																																																																																												
Middle Channel	Middle Channel																																																																																																
 <table border="1" data-bbox="239 1131 638 1232"> <thead> <tr> <th>Start</th> <th>Stop</th> <th>RBW</th> <th>Freq</th> <th>PwrAve</th> <th>ΔLimit</th> </tr> <tr> <th>[Hz]</th> <th>[Hz]</th> <th>[Hz]</th> <th>[Hz]</th> <th>[dBm]</th> <th>[dB]</th> </tr> </thead> <tbody> <tr> <td>30,000 M</td> <td>1,000 G</td> <td>1,000 M</td> <td>991,685000 M</td> <td>-41.83</td> <td>-28.83</td> </tr> <tr> <td>1,000 G</td> <td>1,845 G</td> <td>1,000 M</td> <td>1,084530 G</td> <td>-40.31</td> <td>-27.31</td> </tr> <tr> <td>1,845 G</td> <td>3,000 G</td> <td>1,000 M</td> <td>2,986745 G</td> <td>-39.66</td> <td>-26.66</td> </tr> <tr> <td>3,000 G</td> <td>7,000 G</td> <td>1,000 M</td> <td>3,397000 G</td> <td>-39.25</td> <td>-24.25</td> </tr> <tr> <td>7,000 G</td> <td>13,600 G</td> <td>1,000 M</td> <td>10,227400 G</td> <td>-34.64</td> <td>-21.64</td> </tr> <tr> <td>13,600 G</td> <td>19,100 G</td> <td>1,000 M</td> <td>15,415688 G</td> <td>-29.51</td> <td>-12.51</td> </tr> </tbody> </table> <p>Date: 25.FEB.2016 11:07:20</p>	Start	Stop	RBW	Freq	PwrAve	ΔLimit	[Hz]	[Hz]	[Hz]	[Hz]	[dBm]	[dB]	30,000 M	1,000 G	1,000 M	991,685000 M	-41.83	-28.83	1,000 G	1,845 G	1,000 M	1,084530 G	-40.31	-27.31	1,845 G	3,000 G	1,000 M	2,986745 G	-39.66	-26.66	3,000 G	7,000 G	1,000 M	3,397000 G	-39.25	-24.25	7,000 G	13,600 G	1,000 M	10,227400 G	-34.64	-21.64	13,600 G	19,100 G	1,000 M	15,415688 G	-29.51	-12.51	 <table border="1" data-bbox="893 1131 1292 1232"> <thead> <tr> <th>Start</th> <th>Stop</th> <th>RBW</th> <th>Freq</th> <th>PwrAve</th> <th>ΔLimit</th> </tr> <tr> <th>[Hz]</th> <th>[Hz]</th> <th>[Hz]</th> <th>[Hz]</th> <th>[dBm]</th> <th>[dB]</th> </tr> </thead> <tbody> <tr> <td>30,000 M</td> <td>1,000 G</td> <td>1,000 M</td> <td>141,792500 M</td> <td>-39.92</td> <td>-22.92</td> </tr> <tr> <td>1,000 G</td> <td>1,845 G</td> <td>1,000 M</td> <td>3,059150 G</td> <td>-40.56</td> <td>-27.56</td> </tr> <tr> <td>1,845 G</td> <td>3,000 G</td> <td>1,000 M</td> <td>2,876310 G</td> <td>-39.92</td> <td>-26.92</td> </tr> <tr> <td>3,000 G</td> <td>7,000 G</td> <td>1,000 M</td> <td>3,034000 G</td> <td>-37.34</td> <td>-24.34</td> </tr> <tr> <td>7,000 G</td> <td>13,600 G</td> <td>1,000 M</td> <td>10,230700 G</td> <td>-34.16</td> <td>-21.16</td> </tr> <tr> <td>13,600 G</td> <td>19,100 G</td> <td>1,000 M</td> <td>15,179875 G</td> <td>-29.57</td> <td>-12.57</td> </tr> </tbody> </table> <p>Date: 25.FEB.2016 11:37:43</p>	Start	Stop	RBW	Freq	PwrAve	ΔLimit	[Hz]	[Hz]	[Hz]	[Hz]	[dBm]	[dB]	30,000 M	1,000 G	1,000 M	141,792500 M	-39.92	-22.92	1,000 G	1,845 G	1,000 M	3,059150 G	-40.56	-27.56	1,845 G	3,000 G	1,000 M	2,876310 G	-39.92	-26.92	3,000 G	7,000 G	1,000 M	3,034000 G	-37.34	-24.34	7,000 G	13,600 G	1,000 M	10,230700 G	-34.16	-21.16	13,600 G	19,100 G	1,000 M	15,179875 G	-29.57	-12.57
Start	Stop	RBW	Freq	PwrAve	ΔLimit																																																																																												
[Hz]	[Hz]	[Hz]	[Hz]	[dBm]	[dB]																																																																																												
30,000 M	1,000 G	1,000 M	991,685000 M	-41.83	-28.83																																																																																												
1,000 G	1,845 G	1,000 M	1,084530 G	-40.31	-27.31																																																																																												
1,845 G	3,000 G	1,000 M	2,986745 G	-39.66	-26.66																																																																																												
3,000 G	7,000 G	1,000 M	3,397000 G	-39.25	-24.25																																																																																												
7,000 G	13,600 G	1,000 M	10,227400 G	-34.64	-21.64																																																																																												
13,600 G	19,100 G	1,000 M	15,415688 G	-29.51	-12.51																																																																																												
Start	Stop	RBW	Freq	PwrAve	ΔLimit																																																																																												
[Hz]	[Hz]	[Hz]	[Hz]	[dBm]	[dB]																																																																																												
30,000 M	1,000 G	1,000 M	141,792500 M	-39.92	-22.92																																																																																												
1,000 G	1,845 G	1,000 M	3,059150 G	-40.56	-27.56																																																																																												
1,845 G	3,000 G	1,000 M	2,876310 G	-39.92	-26.92																																																																																												
3,000 G	7,000 G	1,000 M	3,034000 G	-37.34	-24.34																																																																																												
7,000 G	13,600 G	1,000 M	10,230700 G	-34.16	-21.16																																																																																												
13,600 G	19,100 G	1,000 M	15,179875 G	-29.57	-12.57																																																																																												
Highest Channel	Highest Channel																																																																																																
 <table border="1" data-bbox="239 1646 638 1747"> <thead> <tr> <th>Start</th> <th>Stop</th> <th>RBW</th> <th>Freq</th> <th>PwrAve</th> <th>ΔLimit</th> </tr> <tr> <th>[Hz]</th> <th>[Hz]</th> <th>[Hz]</th> <th>[Hz]</th> <th>[dBm]</th> <th>[dB]</th> </tr> </thead> <tbody> <tr> <td>30,000 M</td> <td>1,000 G</td> <td>1,000 M</td> <td>171,620000 M</td> <td>-30.14</td> <td>-17.14</td> </tr> <tr> <td>1,000 G</td> <td>1,845 G</td> <td>1,000 M</td> <td>1,222658 G</td> <td>-40.79</td> <td>-27.79</td> </tr> <tr> <td>1,845 G</td> <td>3,000 G</td> <td>1,000 M</td> <td>1,932071 G</td> <td>-39.04</td> <td>-26.04</td> </tr> <tr> <td>3,000 G</td> <td>7,000 G</td> <td>1,000 M</td> <td>3,084000 G</td> <td>-37.07</td> <td>-24.07</td> </tr> <tr> <td>7,000 G</td> <td>13,600 G</td> <td>1,000 M</td> <td>10,226575 G</td> <td>-34.34</td> <td>-21.34</td> </tr> <tr> <td>13,600 G</td> <td>19,100 G</td> <td>1,000 M</td> <td>15,286438 G</td> <td>-26.02</td> <td>-13.02</td> </tr> </tbody> </table> <p>Date: 25.FEB.2016 11:08:16</p>	Start	Stop	RBW	Freq	PwrAve	ΔLimit	[Hz]	[Hz]	[Hz]	[Hz]	[dBm]	[dB]	30,000 M	1,000 G	1,000 M	171,620000 M	-30.14	-17.14	1,000 G	1,845 G	1,000 M	1,222658 G	-40.79	-27.79	1,845 G	3,000 G	1,000 M	1,932071 G	-39.04	-26.04	3,000 G	7,000 G	1,000 M	3,084000 G	-37.07	-24.07	7,000 G	13,600 G	1,000 M	10,226575 G	-34.34	-21.34	13,600 G	19,100 G	1,000 M	15,286438 G	-26.02	-13.02	 <table border="1" data-bbox="893 1646 1292 1747"> <thead> <tr> <th>Start</th> <th>Stop</th> <th>RBW</th> <th>Freq</th> <th>PwrAve</th> <th>ΔLimit</th> </tr> <tr> <th>[Hz]</th> <th>[Hz]</th> <th>[Hz]</th> <th>[Hz]</th> <th>[dBm]</th> <th>[dB]</th> </tr> </thead> <tbody> <tr> <td>30,000 M</td> <td>1,000 G</td> <td>1,000 M</td> <td>171,620000 M</td> <td>-32.22</td> <td>-19.22</td> </tr> <tr> <td>1,000 G</td> <td>1,845 G</td> <td>1,000 M</td> <td>1,228460 G</td> <td>-40.57</td> <td>-27.57</td> </tr> <tr> <td>1,845 G</td> <td>3,000 G</td> <td>1,000 M</td> <td>1,932071 G</td> <td>-39.04</td> <td>-27.04</td> </tr> <tr> <td>3,000 G</td> <td>7,000 G</td> <td>1,000 M</td> <td>4,093000 G</td> <td>-37.05</td> <td>-24.05</td> </tr> <tr> <td>7,000 G</td> <td>13,600 G</td> <td>1,000 M</td> <td>10,230700 G</td> <td>-33.48</td> <td>-20.48</td> </tr> <tr> <td>13,600 G</td> <td>19,100 G</td> <td>1,000 M</td> <td>14,992875 G</td> <td>-29.88</td> <td>-12.88</td> </tr> </tbody> </table> <p>Date: 25.FEB.2016 11:39:18</p>	Start	Stop	RBW	Freq	PwrAve	ΔLimit	[Hz]	[Hz]	[Hz]	[Hz]	[dBm]	[dB]	30,000 M	1,000 G	1,000 M	171,620000 M	-32.22	-19.22	1,000 G	1,845 G	1,000 M	1,228460 G	-40.57	-27.57	1,845 G	3,000 G	1,000 M	1,932071 G	-39.04	-27.04	3,000 G	7,000 G	1,000 M	4,093000 G	-37.05	-24.05	7,000 G	13,600 G	1,000 M	10,230700 G	-33.48	-20.48	13,600 G	19,100 G	1,000 M	14,992875 G	-29.88	-12.88
Start	Stop	RBW	Freq	PwrAve	ΔLimit																																																																																												
[Hz]	[Hz]	[Hz]	[Hz]	[dBm]	[dB]																																																																																												
30,000 M	1,000 G	1,000 M	171,620000 M	-30.14	-17.14																																																																																												
1,000 G	1,845 G	1,000 M	1,222658 G	-40.79	-27.79																																																																																												
1,845 G	3,000 G	1,000 M	1,932071 G	-39.04	-26.04																																																																																												
3,000 G	7,000 G	1,000 M	3,084000 G	-37.07	-24.07																																																																																												
7,000 G	13,600 G	1,000 M	10,226575 G	-34.34	-21.34																																																																																												
13,600 G	19,100 G	1,000 M	15,286438 G	-26.02	-13.02																																																																																												
Start	Stop	RBW	Freq	PwrAve	ΔLimit																																																																																												
[Hz]	[Hz]	[Hz]	[Hz]	[dBm]	[dB]																																																																																												
30,000 M	1,000 G	1,000 M	171,620000 M	-32.22	-19.22																																																																																												
1,000 G	1,845 G	1,000 M	1,228460 G	-40.57	-27.57																																																																																												
1,845 G	3,000 G	1,000 M	1,932071 G	-39.04	-27.04																																																																																												
3,000 G	7,000 G	1,000 M	4,093000 G	-37.05	-24.05																																																																																												
7,000 G	13,600 G	1,000 M	10,230700 G	-33.48	-20.48																																																																																												
13,600 G	19,100 G	1,000 M	14,992875 G	-29.88	-12.88																																																																																												



Frequency Stability

Test Conditions Temperature (°C)	Middle Channel Voltage (Volt)	GSM850 (GSM)	GSM850 (EDGE class 8)	Limit 2.5ppm
		Deviation (ppm)		Result
50	Normal Voltage	0.0084	0.0048	PASS
40	Normal Voltage	0.0048	0.0024	
30	Normal Voltage	0.0012	0.0024	
20(Ref.)	Normal Voltage	0.0000	0.0000	
10	Normal Voltage	0.0048	0.0072	
0	Normal Voltage	0.0024	0.0012	
-10	Normal Voltage	0.0060	0.0048	
-20	Normal Voltage	0.0036	0.0036	
-30	Normal Voltage	0.0036	0.0000	
20	Maximum Voltage	0.0000	0.0036	
20	Normal Voltage	0.0012	0.0048	
20	Battery End Point	0.0012	0.0012	

Test Conditions Temperature (°C)	Middle Channel Voltage (Volt)	GSM1900 (GSM)	GSM1900 (EDGE class 8)	Limit Note 2.
		Deviation (ppm)		Result
50	Normal Voltage	0.0043	0.0027	PASS
40	Normal Voltage	0.0027	0.0032	
30	Normal Voltage	0.0016	0.0021	
20(Ref.)	Normal Voltage	0.0000	0.0000	
10	Normal Voltage	0.0021	0.0011	
0	Normal Voltage	0.0011	0.0011	
-10	Normal Voltage	0.0011	0.0037	
-20	Normal Voltage	0.0016	0.0043	
-30	Normal Voltage	0.0005	0.0016	
20	Maximum Voltage	0.0016	0.0005	
20	Normal Voltage	0.0021	0.0011	
20	Battery End Point	0.0000	0.0021	

Note:

1. Normal Voltage = 3.7V. ; Battery End Point (BEP) = 3.5 V. ; Maximum Voltage =4.1 V
2. The frequency fundamental emissions stay within the authorized frequency block.



A2. WCDMA

Peak-to-Average Ratio

Mode	WCDMA Band V	WCDMA Band II		Limit: 13dB
Mod.	RMC 12.2Kbps	RMC 12.2Kbps		Result
Lowest CH	3.32	3.32		PASS
Middle CH	3.32	3.28		
Highest CH	3.08	3.40		

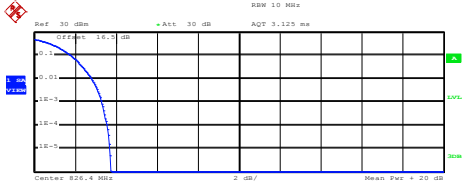
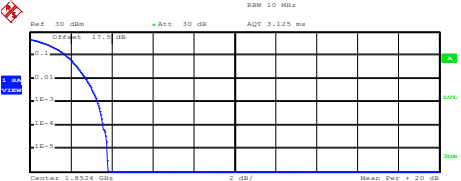
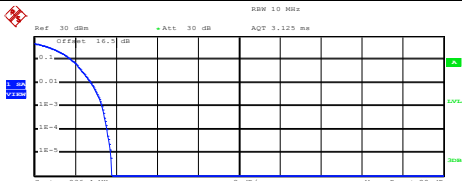
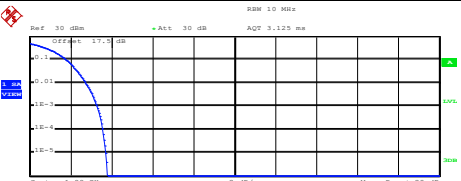
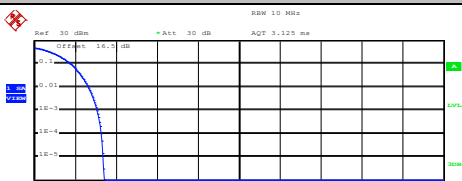
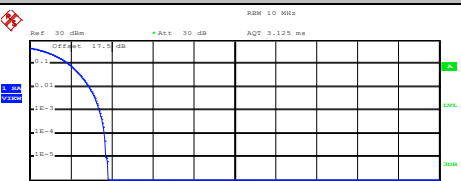

WCDMA Band V (RMC 12.2Kbps)	WCDMA Band II (RMC 12.2Kbps)																
<p align="center">Lowest Channel</p>  <p>Center 826.4 MHz 2 dB/ Mean Pwr + 20 dB</p> <p>Complementary Cumulative Distribution Function (100000 samples) Trace 1 Mean 19.96 dBm Peak 23.69 dBm Crest 3.73 dB</p> <table border="0"> <tr><td>10 %</td><td>1.80 dB</td></tr> <tr><td>1 %</td><td>2.80 dB</td></tr> <tr><td>.1 %</td><td>3.32 dB</td></tr> <tr><td>.01 %</td><td>3.56 dB</td></tr> </table> <p>Date: 25.FEB.2016 14:01:14</p>	10 %	1.80 dB	1 %	2.80 dB	.1 %	3.32 dB	.01 %	3.56 dB	<p align="center">Lowest Channel</p>  <p>Center 1.8524 GHz 2 dB/ Mean Pwr + 20 dB</p> <p>Complementary Cumulative Distribution Function (100000 samples) Trace 1 Mean 20.31 dBm Peak 24.11 dBm Crest 3.80 dB</p> <table border="0"> <tr><td>10 %</td><td>1.76 dB</td></tr> <tr><td>1 %</td><td>2.72 dB</td></tr> <tr><td>.1 %</td><td>3.32 dB</td></tr> <tr><td>.01 %</td><td>3.56 dB</td></tr> </table> <p>Date: 25.FEB.2016 13:47:25</p>	10 %	1.76 dB	1 %	2.72 dB	.1 %	3.32 dB	.01 %	3.56 dB
10 %	1.80 dB																
1 %	2.80 dB																
.1 %	3.32 dB																
.01 %	3.56 dB																
10 %	1.76 dB																
1 %	2.72 dB																
.1 %	3.32 dB																
.01 %	3.56 dB																
<p align="center">Middle Channel</p>  <p>Center 836.4 MHz 2 dB/ Mean Pwr + 20 dB</p> <p>Complementary Cumulative Distribution Function (100000 samples) Trace 1 Mean 19.75 dBm Peak 23.55 dBm Crest 3.80 dB</p> <table border="0"> <tr><td>10 %</td><td>1.80 dB</td></tr> <tr><td>1 %</td><td>2.80 dB</td></tr> <tr><td>.1 %</td><td>3.32 dB</td></tr> <tr><td>.01 %</td><td>3.56 dB</td></tr> </table> <p>Date: 25.FEB.2016 14:01:24</p>	10 %	1.80 dB	1 %	2.80 dB	.1 %	3.32 dB	.01 %	3.56 dB	<p align="center">Middle Channel</p>  <p>Center 1.88 GHz 2 dB/ Mean Pwr + 20 dB</p> <p>Complementary Cumulative Distribution Function (100000 samples) Trace 1 Mean 20.12 dBm Peak 23.90 dBm Crest 3.78 dB</p> <table border="0"> <tr><td>10 %</td><td>1.76 dB</td></tr> <tr><td>1 %</td><td>2.72 dB</td></tr> <tr><td>.1 %</td><td>3.28 dB</td></tr> <tr><td>.01 %</td><td>3.56 dB</td></tr> </table> <p>Date: 25.FEB.2016 13:47:38</p>	10 %	1.76 dB	1 %	2.72 dB	.1 %	3.28 dB	.01 %	3.56 dB
10 %	1.80 dB																
1 %	2.80 dB																
.1 %	3.32 dB																
.01 %	3.56 dB																
10 %	1.76 dB																
1 %	2.72 dB																
.1 %	3.28 dB																
.01 %	3.56 dB																
<p align="center">Highest Channel</p>  <p>Center 846.6 MHz 2 dB/ Mean Pwr + 20 dB</p> <p>Complementary Cumulative Distribution Function (100000 samples) Trace 1 Mean 19.72 dBm Peak 23.12 dBm Crest 3.40 dB</p> <table border="0"> <tr><td>10 %</td><td>1.80 dB</td></tr> <tr><td>1 %</td><td>2.64 dB</td></tr> <tr><td>.1 %</td><td>3.08 dB</td></tr> <tr><td>.01 %</td><td>3.28 dB</td></tr> </table> <p>Date: 25.FEB.2016 14:01:34</p>	10 %	1.80 dB	1 %	2.64 dB	.1 %	3.08 dB	.01 %	3.28 dB	<p align="center">Highest Channel</p>  <p>Center 1.9076 GHz 2 dB/ Mean Pwr + 20 dB</p> <p>Complementary Cumulative Distribution Function (100000 samples) Trace 1 Mean 20.56 dBm Peak 24.39 dBm Crest 3.84 dB</p> <table border="0"> <tr><td>10 %</td><td>1.92 dB</td></tr> <tr><td>1 %</td><td>2.92 dB</td></tr> <tr><td>.1 %</td><td>3.40 dB</td></tr> <tr><td>.01 %</td><td>3.64 dB</td></tr> </table> <p>Date: 25.FEB.2016 13:47:49</p>	10 %	1.92 dB	1 %	2.92 dB	.1 %	3.40 dB	.01 %	3.64 dB
10 %	1.80 dB																
1 %	2.64 dB																
.1 %	3.08 dB																
.01 %	3.28 dB																
10 %	1.92 dB																
1 %	2.92 dB																
.1 %	3.40 dB																
.01 %	3.64 dB																



26dB Bandwidth

Mode	WCDMA Band V	WCDMA Band II	
Mod.	RMC 12.2Kbps	RMC 12.2Kbps	
Lowest CH	4.67	4.69	
Middle CH	4.69	4.69	
Highest CH	4.69	4.68	



WCDMA Band V (RMC 12.2Kbps)

Lowest Channel

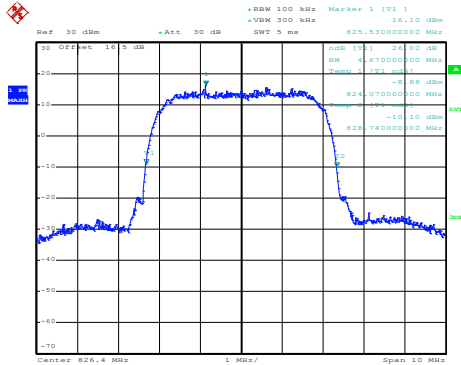

Date: 25.FEB.2016 13:53:29

WCDMA Band II (RMC 12.2Kbps)

Lowest Channel

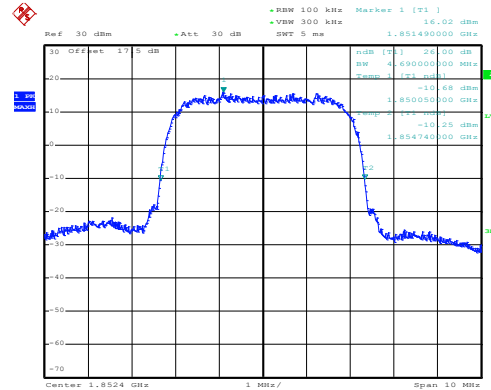

Date: 25.FEB.2016 11:55:48

Middle Channel

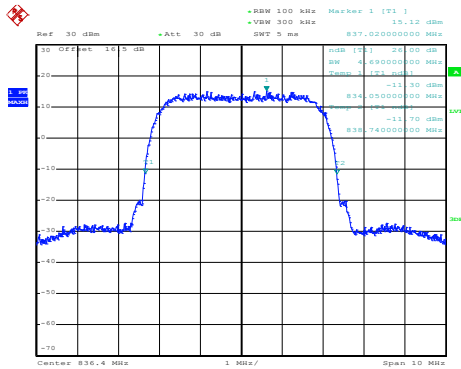

Date: 25.FEB.2016 13:53:57

Middle Channel

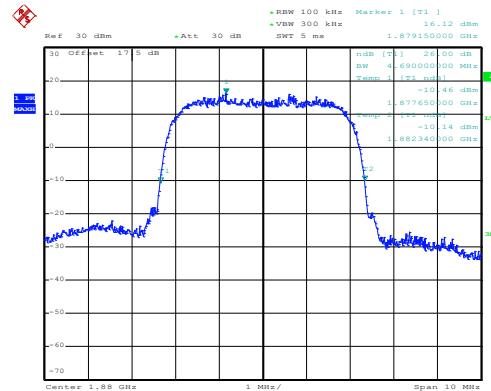

Date: 25.FEB.2016 11:56:16

Highest Channel

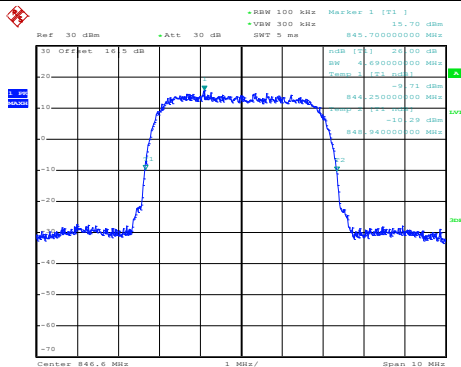

Date: 25.FEB.2016 13:54:25

Highest Channel

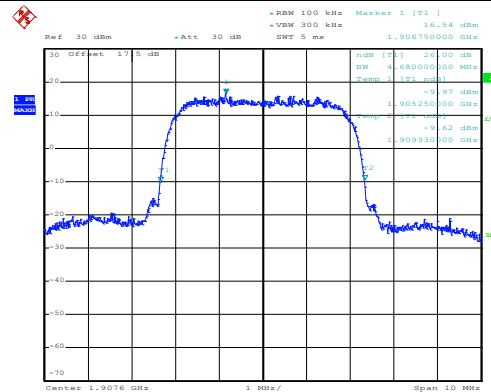

Date: 25.FEB.2016 11:56:44



Occupied Bandwidth

Mode	WCDMA Band V	WCDMA Band II	
Mod.	RMC 12.2Kbps	RMC 12.2Kbps	
Lowest CH	4.16	4.17	
Middle CH	4.17	4.16	
Highest CH	4.17	4.18	

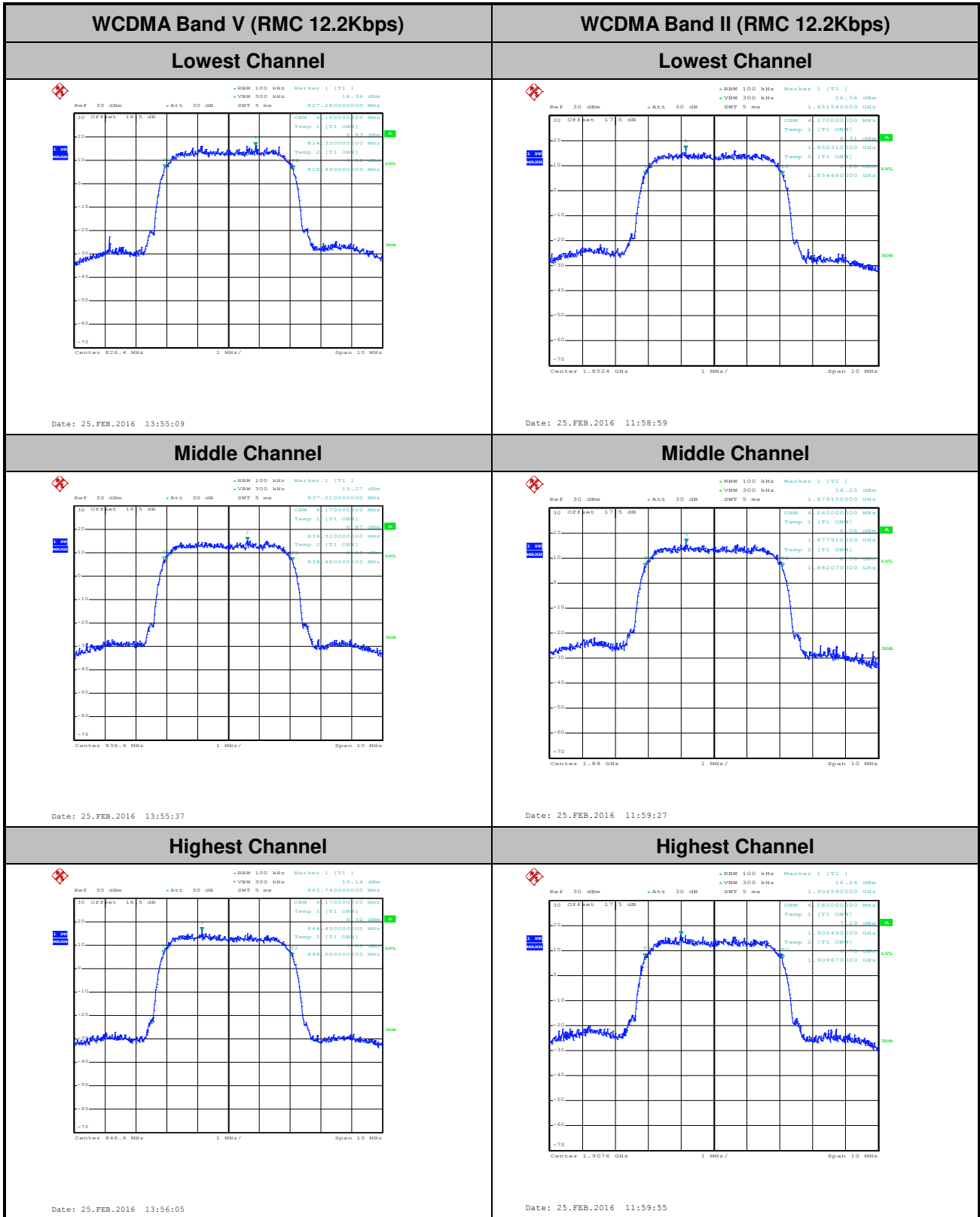



Conducted Band Edge



WCDMA Band V (RMC 12.2Kbps)

Lowest Band Edge

Highest Band Edge

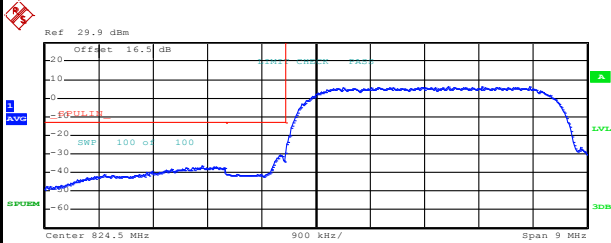

Start [Hz]	Stop [Hz]	RBW [Hz]	Freq [Hz]	PwrAbs [dBm]	ΔLimit [dB]
820.000 M	823.000 M	100.00 k	822.607000 M	-36.96	-23.56
823.000 M	824.000 M	50.00 k	823.904000 M	-30.66	-17.66
824.000 M	829.000 M	100.00 k	827.255000 M	6.21	-28.79

Date: 25.FEB.2016 14:04:24

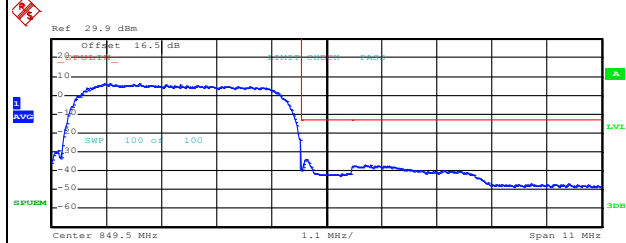

Start [Hz]	Stop [Hz]	RBW [Hz]	Freq [Hz]	PwrAbs [dBm]	ΔLimit [dB]
844.000 M	849.000 M	100.00 k	845.170000 M	6.34	-28.66
849.000 M	850.000 M	50.00 k	849.076000 M	-33.85	-20.85
850.000 M	855.000 M	100.00 k	850.265000 M	-37.20	-24.20

Date: 25.FEB.2016 14:07:07



WCDMA Band II (RMC 12.2Kbps)

Lowest Band Edge

Highest Band Edge

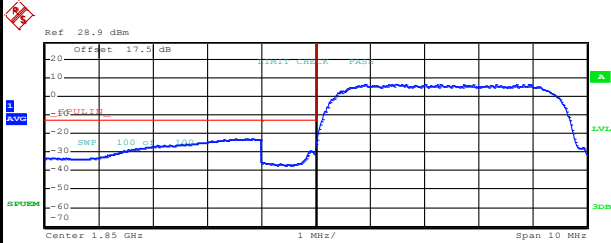

Start [Hz]	Stop [Hz]	RBW [Hz]	Freq [Hz]	PwrAbs [dBm]	ΔLimit [dB]
1.845 G	1.849 G	1.00 M	1.848824 G	-22.93	-9.88
1.849 G	1.850 G	50.00 k	1.849900 G	-29.40	-16.40
1.850 G	1.855 G	100.00 k	1.851500 G	6.55	-28.45

Date: 25.FEB.2016 12:03:19

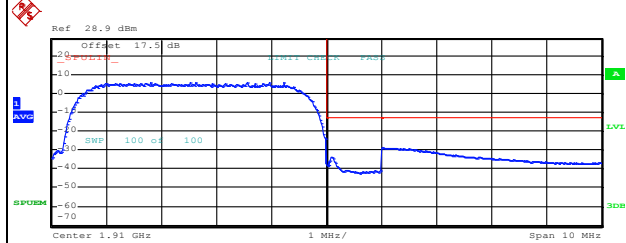

Start [Hz]	Stop [Hz]	RBW [Hz]	Freq [Hz]	PwrAbs [dBm]	ΔLimit [dB]
1.905 G	1.910 G	100.00 k	1.906795 G	5.64	-29.36
1.910 G	1.911 G	50.00 k	1.910096 G	-34.17	-21.17
1.911 G	1.915 G	1.00 M	1.911012 G	-28.95	-15.95

Date: 25.FEB.2016 12:06:02



Conducted Spurious Emission



WCDMA Band V (RMC 12.2Kbps)

Lowest Channel

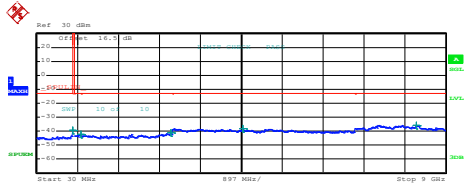

Start [Hz]	Stop [Hz]	RBW [Hz]	Freq [Hz]	PwrAbs [dBm]	ΔLimit [dB]
30,000 M	820,000 M	1,000 M	819,402500 M	-39.17	-26.17
855,000 M	1,000 G	1,000 G	999,746200 M	-42.31	-29.31
1,000 G	3,000 G	1,000 M	2,999,600 G	-42.28	-28.28
3,000 G	7,000 G	1,000 M	4,547000 G	-38.32	-25.32
7,000 G	9,000 G	1,000 M	8,361500 G	-35.62	-22.62

Date: 25.FEB.2016 13:58:05

WCDMA Band II (RMC 12.2Kbps)

Lowest Channel

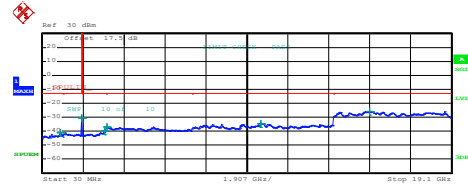

Start [Hz]	Stop [Hz]	RBW [Hz]	Freq [Hz]	PwrAbs [dBm]	ΔLimit [dB]
30,000 M	1,000 G	1,000 M	883,115000 M	-41.27	-28.27
1,000 G	3,000 G	1,000 M	3,844578 G	-30.45	-17.45
3,000 G	7,000 G	1,000 M	2,992004 G	-39.59	-26.59
7,000 G	13,600 G	1,000 M	10,224925 G	-34.43	-21.43
13,600 G	19,100 G	1,000 M	15,201938 G	-25.68	-12.68

Date: 25.FEB.2016 12:56:04

Middle Channel

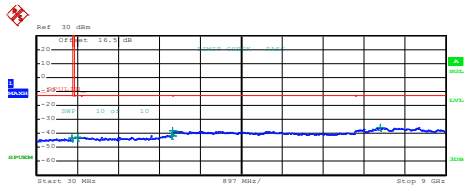

Start [Hz]	Stop [Hz]	RBW [Hz]	Freq [Hz]	PwrAbs [dBm]	ΔLimit [dB]
30,000 M	820,000 M	1,000 M	800,422500 M	-43.24	-30.24
855,000 M	1,000 G	1,000 M	921,228755 M	-42.82	-29.82
1,000 G	3,000 G	1,000 M	2,983000 G	-41.41	-28.41
3,000 G	7,000 G	1,000 M	3,051000 G	-38.29	-25.29
7,000 G	9,000 G	1,000 M	7,369000 G	-35.86	-22.86

Date: 25.FEB.2016 13:58:50

Middle Channel

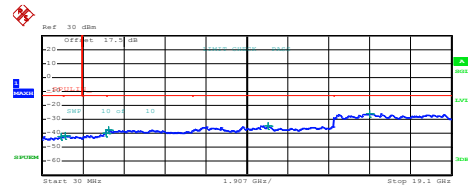

Start [Hz]	Stop [Hz]	RBW [Hz]	Freq [Hz]	PwrAbs [dBm]	ΔLimit [dB]
30,000 M	1,000 G	1,000 M	903,247500 M	-41.96	-28.96
1,000 G	3,000 G	1,000 M	3,082176 G	-41.86	-28.86
3,000 G	7,000 G	1,000 M	2,997830 G	-39.62	-26.62
7,000 G	13,600 G	1,000 M	3,120000 G	-37.37	-24.37
13,600 G	19,100 G	1,000 M	15,253750 G	-34.65	-21.65
			15,271313 G	-25.71	-12.71

Date: 25.FEB.2016 12:56:49

Highest Channel

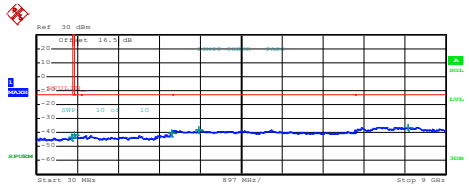

Start [Hz]	Stop [Hz]	RBW [Hz]	Freq [Hz]	PwrAbs [dBm]	ΔLimit [dB]
30,000 M	820,000 M	1,000 M	798,467500 M	-43.42	-30.42
855,000 M	1,000 G	1,000 M	850,036250 M	-41.47	-28.47
1,000 G	3,000 G	1,000 M	2,990000 G	-40.76	-27.76
3,000 G	7,000 G	1,000 M	3,585000 G	-38.22	-25.22
7,000 G	9,000 G	1,000 M	8,167000 G	-36.18	-23.18

Date: 25.FEB.2016 13:59:35

Highest Channel

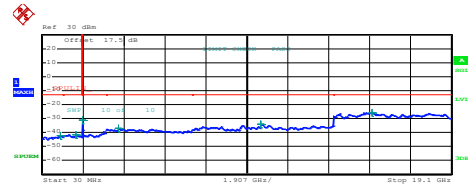

Start [Hz]	Stop [Hz]	RBW [Hz]	Freq [Hz]	PwrAbs [dBm]	ΔLimit [dB]
30,000 M	1,000 G	1,000 M	873,117500 M	-43.32	-29.32
1,000 G	3,000 G	1,000 M	3,594035 G	-41.41	-28.41
3,000 G	7,000 G	1,000 M	2,993042 G	-39.59	-26.59
7,000 G	13,600 G	1,000 M	3,591000 G	-37.24	-24.24
13,600 G	19,100 G	1,000 M	15,217500 G	-34.09	-21.09
			15,398500 G	-25.91	-12.91

Date: 25.FEB.2016 12:57:35



Frequency Stability

Test Conditions Temperature (°C)	Middle Channel Voltage (Volt)	WCDMA Band V (RMC 12.2Kbps)	Limit 2.5ppm
		Deviation (ppm)	Result
50	Normal Voltage	0.0072	PASS
40	Normal Voltage	0.0036	
30	Normal Voltage	0.0120	
20(Ref.)	Normal Voltage	0.0000	
10	Normal Voltage	0.0036	
0	Normal Voltage	0.0120	
-10	Normal Voltage	0.0048	
-20	Normal Voltage	0.0084	
-30	Normal Voltage	0.0060	
20	Maximum Voltage	0.0024	
20	Normal Voltage	0.0012	
20	Battery End Point	0.0048	

Test Conditions Temperature (°C)	Middle Channel Voltage (Volt)	WCDMA Band II (RMC 12.2Kbps)	Limit Note 2.
		Deviation (ppm)	Result
50	Normal Voltage	0.0021	PASS
40	Normal Voltage	0.0005	
30	Normal Voltage	0.0080	
20(Ref.)	Normal Voltage	0.0000	
10	Normal Voltage	0.0011	
0	Normal Voltage	0.0005	
-10	Normal Voltage	0.0027	
-20	Normal Voltage	0.0011	
-30	Normal Voltage	0.0016	
20	Maximum Voltage	0.0021	
20	Normal Voltage	0.0005	
20	Battery End Point	0.0011	

Note:

1. Normal Voltage = 3.7V. ; Battery End Point (BEP) = 3.5 V. ; Maximum Voltage =4.1 V
2. The frequency fundamental emissions stay within the authorized frequency block.



Appendix B. Test Results of Radiated Test

ERP/EIRP

Channel	Mode	Horizontal		Vertical	
		ERP(dBm)	ERP(W)	ERP(dBm)	ERP(W)
Lowest	GSM850 GSM	15.81	0.0381	24.52	0.2831
Middle		16.80	0.0479	25.41	0.3475
Highest		17.84	0.0608	26.28	0.4246
Lowest	GSM850 EDGE class 8	10.17	0.0104	19.13	0.0818
Middle		10.89	0.0123	19.75	0.0944
Highest		12.39	0.0173	20.99	0.1256
Lowest	WCDMA Band V RMC 12.2Kbps	6.69	0.0047	15.18	0.0330
Middle		7.69	0.0059	16.11	0.0408
Highest		9.01	0.0080	17.28	0.0535
Limit	ERP < 7W	Result		PASS	

Channel	Mode	Horizontal		Vertical	
		EIRP(dBm)	EIRP(W)	EIRP(dBm)	EIRP(W)
Lowest	GSM1900 GSM	25.81	0.3811	27.35	0.5433
Middle		25.78	0.3784	26.79	0.4775
Highest		25.39	0.3459	26.17	0.4140
Lowest	GSM1900 EDGE class 8	22.35	0.1718	23.34	0.2158
Middle		22.30	0.1698	23.01	0.2000
Highest		21.02	0.1265	22.53	0.1791
Lowest	WCDMA Band II RMC 12.2Kbps	18.23	0.0665	19.77	0.0948
Middle		18.49	0.0706	19.91	0.0979
Highest		18.69	0.0740	20.10	0.1023
Limit	EIRP < 2W	Result		PASS	



Radiated Spurious Emission

GSM850 (GSM)									
Channel	Frequency (MHz)	ERP (dBm)	Limit (dBm)	Over Limit (dB)	SPA Reading (dBm)	S.G. Power (dBm)	TX Cable loss (dB)	TX Antenna Gain (dBi)	Polarization (H/V)
Lowest	1648	-47.24	-13	-34.24	-57.01	-49	0.98	4.89	H
	2472	-46.97	-13	-33.97	-60.49	-48.85	1.28	5.32	H
	3296	-54.90	-13	-41.90	-71.01	-58.31	1.54	7.10	H
	4120	-46.61	-13	-33.61	-64.34	-51.25	1.83	8.62	H
	4944	-51.48	-13	-38.48	-71.78	-56.61	2.30	9.59	H
	1648	-54.41	-13	-41.41	-63.61	-56.17	0.98	4.89	V
	2472	-53.34	-13	-40.34	-66.66	-55.22	1.28	5.32	V
	3296	-57.19	-13	-44.19	-73.04	-60.6	1.54	7.10	V
	4120	-54.61	-13	-41.61	-72.21	-59.25	1.83	8.62	V
	4944	-53.52	-13	-40.52	-74.07	-58.65	2.30	9.59	V
Middle	1672	-46.94	-13	-33.94	-56.66	-48.62	0.99	4.82	H
	2512	-40.64	-13	-27.64	-54.17	-42.61	1.29	5.41	H
	3344	-52.15	-13	-39.15	-67.83	-55.76	1.56	7.31	H
	4184	-43.51	-13	-30.51	-61.23	-48.13	1.87	8.64	H
	5016	-51.65	-13	-38.65	-72.01	-56.85	2.35	9.70	H
	1672	-54.00	-13	-41.00	-63.15	-55.68	0.99	4.82	V
	2512	-48.64	-13	-35.64	-62	-50.61	1.29	5.41	V
	3344	-55.94	-13	-42.94	-71.36	-59.55	1.56	7.31	V
	4184	-52.74	-13	-39.74	-70.39	-57.36	1.87	8.64	V
	5016	-53.61	-13	-40.61	-74.28	-58.81	2.35	9.70	V
Highest	1696	-42.91	-13	-29.91	-52.93	-44.51	1.00	4.75	H
	2544	-45.52	-13	-32.52	-59.1	-47.5	1.30	5.44	H
	3392	-51.85	-13	-38.85	-67.62	-55.65	1.57	7.52	H
	4240	-52.00	-13	-39.00	-69.92	-56.6	1.90	8.65	H
	5096	-52.45	-13	-39.45	-73.06	-57.61	2.39	9.70	H
	1696	-48.10	-13	-35.10	-57.5	-49.7	1.00	4.75	V
	2544	-49.33	-13	-36.33	-62.94	-51.31	1.30	5.44	V
	3392	-56.20	-13	-43.20	-71.76	-60	1.57	7.52	V
	4240	-53.53	-13	-40.53	-71.47	-58.13	1.90	8.65	V
5096	-52.84	-13	-39.84	-73.67	-58	2.39	9.70	V	

Remark: Spurious emissions within 30-1000MHz were found more than 20dB below limit line.



GSM850 (EDGE class 8)									
Channel	Frequency (MHz)	ERP (dBm)	Limit (dBm)	Over Limit (dB)	SPA Reading (dBm)	S.G. Power (dBm)	TX Cable loss (dB)	TX Antenna Gain (dBi)	Polarization (H/V)
Lowest	1648	-61.69	-13	-48.69	-71.34	-63.45	0.98	4.89	H
	2472	-59.02	-13	-46.02	-72.5	-60.9	1.28	5.32	H
	3296	-56.89	-13	-43.89	-73.05	-60.3	1.54	7.10	H
	1648	-62.24	-13	-49.24	-71.41	-64	0.98	4.89	V
	2472	-59.33	-13	-46.33	-72.6	-61.21	1.28	5.32	V
	3296	-57.12	-13	-44.12	-72.94	-60.53	1.54	7.10	V
Middle	1672	-61.94	-13	-48.94	-71.69	-63.62	0.99	4.82	H
	2512	-59.03	-13	-46.03	-72.63	-61	1.29	5.41	H
	3344	-57.29	-13	-44.29	-72.99	-60.9	1.56	7.31	H
	1672	-62.44	-13	-49.44	-71.62	-64.12	0.99	4.82	V
	2512	-59.29	-13	-46.29	-72.68	-61.26	1.29	5.41	V
	3344	-57.62	-13	-44.62	-73.02	-61.23	1.56	7.31	V
Highest	1696	-62.15	-13	-49.15	-72.12	-63.75	1.00	4.75	H
	2544	-59.02	-13	-46.02	-72.63	-61	1.30	5.44	H
	3392	-57.33	-13	-44.33	-73.01	-61.13	1.57	7.52	H
	1696	-62.40	-13	-49.40	-71.78	-64	1.00	4.75	V
	2544	-61.37	-13	-48.37	-72.78	-63.35	1.30	5.44	V
	3392	-59.61	-13	-46.61	-73.06	-63.41	1.57	7.52	V

Remark: Spurious emissions within 30-1000MHz were found more than 20dB below limit line.



GSM1900 (GSM)									
Channel	Frequency (MHz)	EIRP (dBm)	Limit (dBm)	Over Limit (dB)	SPA Reading (dBm)	S.G. Power (dBm)	TX Cable loss (dB)	TX Antenna Gain (dBi)	Polarization (H/V)
Lowest	3700	-45.95	-13	-32.95	-63.38	-52.52	1.67	8.24	H
	5548	-35.10	-13	-22.10	-56.76	-42.17	2.65	9.72	H
	7403	-26.86	-13	-13.86	-55.18	-36.01	2.46	11.61	H
	9251	-39.04	-13	-26.04	-69.76	-49.1	2.54	12.60	H
	3700	-49.35	-13	-36.35	-66.61	-55.92	1.67	8.24	V
	5548	-37.02	-13	-24.02	-58.85	-44.09	2.65	9.72	V
	7403	-32.70	-13	-19.70	-60.59	-41.85	2.46	11.61	V
	9251	-40.20	-13	-27.20	-69.69	-50.26	2.54	12.60	V
Middle	3763	-40.37	-13	-27.37	-58.03	-47	1.69	8.32	H
	5639	-35.86	-13	-22.86	-57.55	-42.91	2.71	9.76	H
	7522	-31.93	-13	-18.93	-60	-41.32	2.42	11.81	H
	9398	-37.53	-13	-24.53	-68.83	-47.5	2.57	12.54	H
	3763	-50.87	-13	-37.87	-68.3	-57.5	1.69	8.32	V
	5639	-37.75	-13	-24.75	-59.65	-44.8	2.71	9.76	V
	7522	-35.96	-13	-22.96	-63.79	-45.35	2.42	11.81	V
	9398	-43.83	-13	-30.83	-73.83	-53.8	2.57	12.54	V
Highest	3819	-37.14	-13	-24.14	-54.94	-43.82	1.70	8.38	H
	5730	-34.68	-13	-21.68	-59.51	-41.71	2.76	9.79	H
	7641	-35.85	-13	-22.85	-63.31	-45.35	2.38	11.88	H
	9552	-40.54	-13	-27.54	-72.11	-50.41	2.60	12.47	H
	3819	-43.27	-13	-30.27	-60.66	-49.95	1.70	8.38	V
	5730	-37.42	-13	-24.42	-60.1	-44.45	2.76	9.79	V
	7641	-40.23	-13	-27.23	-67.65	-49.73	2.38	11.88	V
	9549	-44.48	-13	-31.48	-74.64	-54.35	2.60	12.47	V

Remark: Spurious emissions within 30-1000MHz were found more than 20dB below limit line.



GSM1900 (EDGE class 8)									
Channel	Frequency (MHz)	EIRP (dBm)	Limit (dBm)	Over Limit (dB)	SPA Reading (dBm)	S.G. Power (dBm)	TX Cable loss (dB)	TX Antenna Gain (dBi)	Polarization (H/V)
Lowest	3700	-55.93	-13	-42.93	-73.32	-62.5	1.67	8.24	H
	5548	-48.44	-13	-35.44	-70.11	-55.51	2.65	9.72	H
	7403	-44.06	-13	-31.06	-72.32	-53.21	2.46	11.61	H
	3700	-50.80	-13	-37.80	-68.04	-57.37	1.67	8.24	V
	5548	-45.53	-13	-32.53	-67.34	-52.6	2.65	9.72	V
	7403	-40.55	-13	-27.55	-68.44	-49.7	2.46	11.61	V
Middle	3756	-47.79	-13	-34.79	-65.41	-54.41	1.68	8.31	H
	5639	-46.39	-13	-33.39	-68.08	-53.44	2.71	9.76	H
	7522	-46.40	-13	-33.40	-65.41	-55.79	2.42	11.81	H
	3756	-43.37	-13	-30.37	-60.75	-49.99	1.68	8.31	V
	5639	-46.24	-13	-33.24	-68.44	-53.29	2.71	9.76	V
	7522	-44.61	-13	-31.61	-72.4	-54	2.42	11.81	V
Highest	3819	-46.50	-13	-33.50	-64.29	-53.18	1.70	8.38	H
	5730	-47.75	-13	-34.75	-69.55	-54.78	2.76	9.79	H
	7641	-47.96	-13	-34.96	-75.4	-57.46	2.38	11.88	H
	3819	-40.60	-13	-27.60	-58	-47.28	1.70	8.38	V
	5730	-45.80	-13	-32.80	-68.43	-52.83	2.76	9.79	V
	7641	-43.75	-13	-30.75	-71.17	-53.25	2.38	11.88	V

Remark: Spurious emissions within 30-1000MHz were found more than 20dB below limit line.



WCDMA Band V(RMC 12.2Kbps)									
Channel	Frequency (MHz)	ERP (dBm)	Limit (dBm)	Over Limit (dB)	SPA Reading (dBm)	S.G. Power (dBm)	TX Cable loss (dB)	TX Antenna Gain (dBi)	Polarization (H/V)
Lowest	1656	-61.95	-13	-48.95	-71.63	-63.68	0.98	4.86	H
	2480	-58.74	-13	-45.74	-72.25	-60.65	1.28	5.34	H
	3304	-56.88	-13	-43.88	-72.84	-60.32	1.54	7.14	H
	1656	-62.47	-13	-49.47	-71.56	-64.2	0.98	4.86	V
	2480	-59.13	-13	-46.13	-72.44	-61.04	1.28	5.34	V
	3304	-57.14	-13	-44.14	-72.94	-60.58	1.54	7.14	V
Middle	1672	-61.24	-13	-48.24	-70.97	-62.92	0.99	4.82	H
	2512	-58.32	-13	-45.32	-71.83	-60.29	1.29	5.41	H
	3344	-57.21	-13	-44.21	-72.88	-60.82	1.56	7.31	H
	1672	-61.97	-13	-48.97	-71.08	-63.65	0.99	4.82	V
	2512	-59.08	-13	-46.08	-72.44	-61.05	1.29	5.41	V
	3344	-57.59	-13	-44.59	-72.98	-61.2	1.56	7.31	V
Highest	1696	-61.76	-13	-48.76	-71.65	-63.36	1.00	4.75	H
	2536	-58.68	-13	-45.68	-72.22	-60.66	1.30	5.43	H
	3384	-57.44	-13	-44.44	-73.1	-61.21	1.57	7.49	H
	1696	-62.40	-13	-49.40	-71.73	-64	1.00	4.75	V
	2536	-58.84	-13	-45.84	-72.27	-60.82	1.30	5.43	V
	3384	-57.58	-13	-44.58	-73.06	-61.35	1.57	7.49	V

Remark: Spurious emissions within 30-1000MHz were found more than 20dB below limit line.



WCDMA Band II(RMC 12.2Kbps)									
Channel	Frequency (MHz)	EIRP (dBm)	Limit (dBm)	Over Limit (dB)	SPA Reading (dBm)	S.G. Power (dBm)	TX Cable loss (dB)	TX Antenna Gain (dBi)	Polarization (H/V)
Lowest	3707	-47.43	-13	-34.43	-64.86	-54.01	1.67	8.25	H
	5555	-47.59	-13	-34.59	-69.26	-54.66	2.66	9.72	H
	7410	-46.02	-13	-33.02	-74.34	-55.18	2.46	11.62	H
	3707	-53.64	-13	-40.64	-70.97	-60.22	1.67	8.25	V
	5555	-49.96	-13	-36.96	-71.76	-57.03	2.66	9.72	V
	7410	-46.76	-13	-33.76	-74.66	-55.92	2.46	11.62	V
Middle	3756	-50.03	-13	-37.03	-67.68	-56.65	1.68	8.31	H
	5639	-50.23	-13	-37.23	-71.9	-57.28	2.71	9.76	H
	7522	-46.13	-13	-33.13	-74.22	-55.52	2.42	11.81	H
	3756	-52.38	-13	-39.38	-69.8	-59	1.68	8.31	V
	5639	-50.85	-13	-37.85	-72.74	-57.9	2.71	9.76	V
	7522	-46.76	-13	-33.76	-74.57	-56.15	2.42	11.81	V
Highest	3812	-45.25	-13	-32.25	-63.03	-51.92	1.70	8.37	H
	5723	-48.70	-13	-35.70	-70.53	-55.74	2.75	9.79	H
	7627	-46.42	-13	-33.42	-73.86	-55.91	2.39	11.88	H
	3812	-49.50	-13	-36.50	-66.94	-56.17	1.70	8.37	V
	5723	-48.57	-13	-35.57	-71.22	-55.61	2.75	9.79	V
	7627	-47.11	-13	-34.11	-74.54	-56.6	2.39	11.88	V

Remark: Spurious emissions within 30-1000MHz were found more than 20dB below limit line.