



FCC/IC RF Test Report

APPLICANT : Sony Mobile Communications AB
EQUIPMENT : Smart phone
BRAND NAME : SONY
TYPE NAME : PM-0771-BV
FCC ID : PY7PM-0771
IC : 4170B-PM0771
STANDARD : FCC Part 15 Subpart C §15.225
IC RSS-210 issue 8

CLASSIFICATION : (DXX) Low Power Communication Device Transmitter

The product was received on Apr. 02, 2014 and testing was completed on Apr. 19, 2014. We, SPORTON INTERNATIONAL INC., would like to declare that the tested sample has been evaluated in accordance with the procedures and shown the compliance with the applicable technical standards.

The test results in this report apply exclusively to the tested model / sample. Without written approval of SPORTON INTERNATIONAL INC., the test report shall not be reproduced except in full.

Reviewed by: Joseph Lin / Supervisor

Approved by: Jones Tsai / Manager



SPORTON INTERNATIONAL INC.

No. 52, Hwa Ya 1st Rd., Hwa Ya Technology Park, Kwei-Shan Hsiang, Tao Yuan Hsien, Taiwan, R.O.C.

SPORTON INTERNATIONAL INC.

TEL : 886-3-327-3456

FAX : 886-3-328-4978

FCC ID : PY7PM-0771

IC : 4170B-PM0771

Page Number : 1 of 32

Report Issued Date : Jun. 09, 2014

Report Version : Rev. 01



Table of Contents

1. GENERAL INFORMATION.....5
1.1 Applicant.....5
1.2 Manufacturer.....5
1.3 Product Details5
1.4 Accessories List.....6
1.5 Table for Test Modes6
1.6 Table for Testing Locations6
1.7 Applied Standards.....7
1.8 Table for Supporting Units7
1.9 Test Configurations.....8
2. TEST RESULT9
2.1 AC Power Line Conducted Emissions Measurement9
2.2 Field Strength of Fundamental Emissions and Mask Measurement13
2.3 20dB Spectrum Bandwidth Measurement18
2.4 Radiated Emissions Measurement.....20
2.5 Frequency Stability Measurement27
2.6 Antenna Requirements30
3. LIST OF MEASURING EQUIPMENT31
4. TEST LOCATION.....32



REVISION HISTORY

REPORT NO.	VERSION	DESCRIPTION	ISSUED DATE
FR440284D	Rev. 01	Initial issue of report	Jun. 09, 2014



SUMMARY OF THE TEST RESULT

Applied Standard: 47 CFR FCC Part 15 Subpart C					
Part	FCC Rule	IC Rule	Description of Test	Result	Under Limit
3.1	15.207	Gen 7.2.2	AC Power Line Conducted Emissions	Complies	10.80 dB at 13.558MHz
3.2	15.225(a)(b)(c)	A2.6	Field Strength of Fundamental Emissions	Complies	63.53 dB at 13.560 MHz
3.3	2.1049	-	20dB Spectrum Bandwidth	Complies	-
3.4	15.225(d) 15.209	A2.6	Radiated Emissions	Complies	20.11 dB at 1.480 MHz for Quasi-Peak
3.5	15.225(e)	A2.6	Frequency Stability	Complies	-
3.6	15.203	-	Antenna Requirements	Complies	-

Test Items	Uncertainty	Remark
AC Power Line Conducted Emissions	± 2.26 dB	Confidence levels of 95%
Radiated Emissions (30MHz~1000MHz)	± 4.70 dB	Confidence levels of 95%



1. GENERAL INFORMATION

1.1 Applicant

Sony Mobile Communications AB

Nya Vattentornet, 22188 Lund, Sweden

1.2 Manufacturer

Compal Communications, INC.

No. 385, Yangguang Street, Neihu, Taipei 11491, Taiwan

1.3 Product Details

For more detailed features description, please refer to the manufacturer's specifications or user's manual.

Items	Description
Power Type	5Vdc from Adapter 4.2Vdc from Li-ion Battery
Modulation	ASK
Channel Number	1
Channel Bandwidth (99%)	2.240 kHz
Max. Field Strength	60.47 dBμV/m
Test Freq. Range	13.553 ~ 13.567MHz
Carrier Frequencies	13.56 MHz (Ch. 1)
Antenna	Loop antenna (Without any antenna connector)
EUT Stage	Production Unit

EUT Information List				
IMEI	HW Version	SW Version	S/N	Performed Test Item
IMEI : 004402452474269	A	18.3.C.0.8	ZH8002JUPJ	RF conducted measurement
IMEI : 004402452477643			ZH80038NS9	Radiated Spurious Emission
IMEI : 004402452477734			ZH8002JVQW	Conducted Emission

1.4 Accessories List

Accessories List	
AC Adapter	Model No. : EP800
	Type No. : CAA-0002016-US B
	SN : 1112W28321732 (for Radiated Spurious Emission) 3113W23610674 (for AC power line Conducted Emission)
Battery	Model No. : LIS1551ERPC
	Type No. : F-4993-128-0
Earphone	Model No. : MH410c
	Type No. : AG-1100
	SN : 12522047001ADD8 (for Radiated Spurious Emission) 12481A10036502 (for AC power line Conducted Emission)
USB Cable	Model No. : AHAB EC450
	Type No. : AI-0700
	SN : 132512DA0631054 (for Radiated Spurious Emission) 132212DF3297482 (for AC power line Conducted Emission)

1.5 Table for Test Modes

Investigation has been done on all the possible configurations for searching the worst cases. The following table is a list of the test modes shown in this test report.

Test Items	
AC Power Line Conducted Emissions	Field Strength of Fundamental Emissions
20dB Spectrum Bandwidth	Frequency Stability
Radiated Emissions 9kHz~30MHz	Radiated Emissions 30MHz~1GHz
Note:	
1. The EUT was programmed to be in continuously transmitting mode.	
2. The ancillary equipment, NFC card, is used to make the EUT (NFC) continuously transmit at 13.56MHz and is placed around 3 cm gap to the EUT.	

1.6 Table for Testing Locations

Test Site No.	Site Category	Location
CO05-HY	Conduction	Hwa Ya
TH02-HY	OVEN Room	Hwa Ya
03CH07-HY	SAC	Hwa Ya

Note : Semi Anechoic Chamber (SAC).



1.7 Applied Standards

According to the specifications of the manufacturer, the EUT must comply with the requirements of the following standards:

- ♦ FCC Part 15 Subpart C §15.225
- ♦ ANSI C63.4-2003
- ♦ IC RSS-210 issue 8

1.8 Table for Supporting Units

Support Unit	Manufacturer	Model	FCC ID
Base Station	R&S	CMU200	N/A
WLAN AP	D-Link	DIR-628	KA2DIR628A2
Bluetooth Earphone	Sony Ericsson	SBH20	PY7-RD0010
Notebook	DELL	Latitude E6320	FCC DoC/ Contains FCC ID: QDS-BRCM1054
SD Card	SanDisk	MicroSD HC	N/A
NFC Card	Metro Taipei	Easy Card	N/A

♦

1.9 Test Configurations

<AC Conducted Emissions>

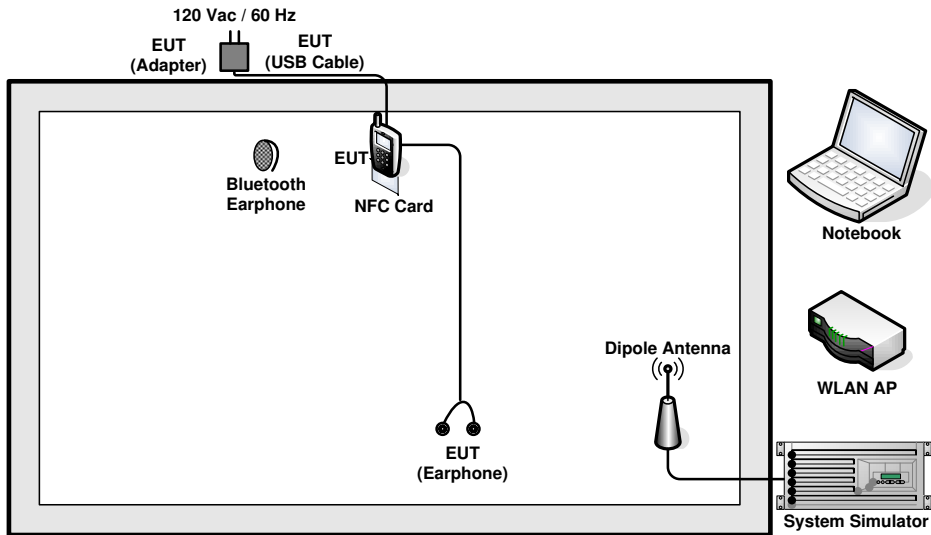

Fundamental Emissions and Mask Measurement

For radiated emissions on frequency range 9kHz~30MHz and 30MHz~1GHz

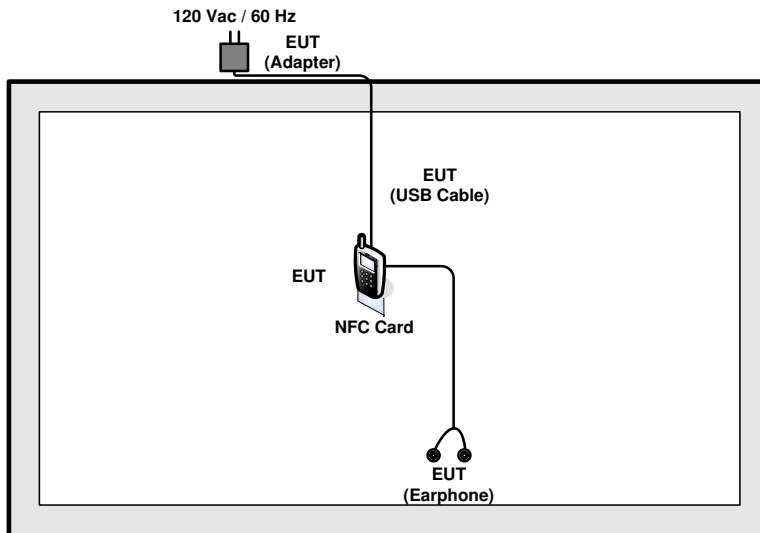

2. TEST RESULT

2.1 AC Power Line Conducted Emissions Measurement

2.1.1 Limit

For a Low-power Radio-frequency device which is designed to be connected to the AC power line, the radio frequency voltage that is conducted back onto the AC power line on any frequency or frequencies within the band 150 kHz to 30 MHz shall not exceed below limits table.

Frequency (MHz)	QP Limit (dB μ V)	AV Limit (dB μ V)
0.15~0.5	66~56	56~46
0.5~5	56	46
5~30	60	50

2.1.2 Measuring Instruments and Setting

Please refer to section 4 of equipments list in this report. The following table is the setting of the receiver.

Receiver Parameters	Setting
Attenuation	10 dB
Start Frequency	0.15 MHz
Stop Frequency	30 MHz
IF Bandwidth	9 kHz

2.1.3 Test Procedures

1. Configure the EUT according to ANSI C63.4. The EUT or host of EUT has to be placed 0.4 meter far from the conducting wall of the shielding room and at least 80 centimeters from any other grounded conducting surface.
2. Connect EUT or host of EUT to the power mains through a line impedance stabilization network (LISN).
3. All the support units are connected to the other LISNs. The LISN should provide 50uH/50ohms coupling impedance.
4. The frequency range from 150 kHz to 30 MHz was searched.
5. Set the test-receiver system to Peak Detect Function and Specified Bandwidth with Maximum Hold Mode.
6. The measurement has to be done between each power line and ground at the power terminal.

2.1.4 Test Setup Layout

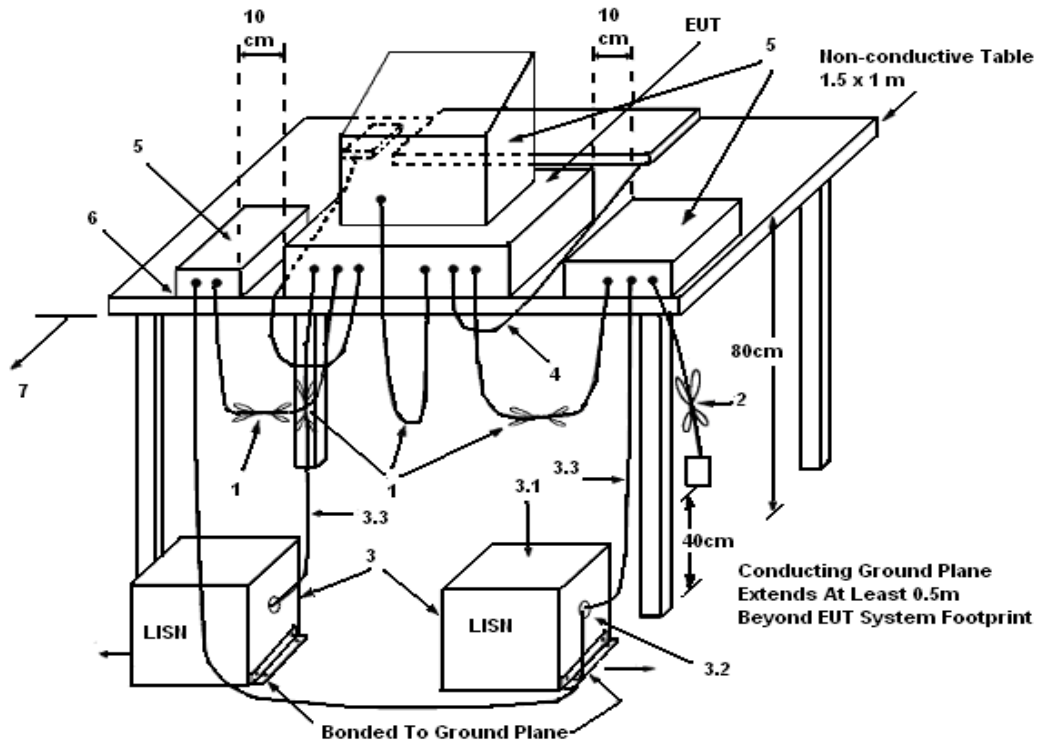

LEGEND:

- (1) Interconnecting cables that hang closer than 40 cm to the ground plane shall be folded back and forth in the center forming a bundle 30 to 40 cm long.
- (2) I/O cables that are not connected to a peripheral shall be bundled in the center. The end of the cable may be terminated, if required, using the correct terminating impedance. The overall length shall not exceed 1 m.
- (3) EUT connected to one LISN. Unused LISN measuring port connectors shall be terminated in 50 Ω. LISN can be placed on top of, or immediately beneath, reference ground plane.
 - (3.1) All other equipment powered from additional LISN(s).
 - (3.2) Multiple outlet strip can be used for multiple power cords of non-EUT equipment.
 - (3.3) LISN at least 80 cm from nearest part of EUT chassis.
- (4) Cables of hand-operated devices, such as keyboards, mice, etc., shall be placed as for normal use.
- (5) Non-EUT components of EUT system being tested.
- (6) Rear of EUT, including peripherals, shall all be aligned and flush with rear of tabletop.
- (7) Rear of tabletop shall be 40 cm removed from a vertical conducting plane that is bonded to the ground plane.

2.1.5 Test Deviation

There is no deviation with the original standard.

2.1.6 Results of AC Power Line Conducted Emissions Measurement

Final Test Date	Apr. 12, 2014	Test Site No.	CO05-HY
Temperature	20~22°C	Humidity	46~48%
Test Engineer	Cosmo Xu	Configuration	Transmitting Mode (13.56MHz)
		Phase	Line
Mode	GSM850 Idle + Bluetooth Link + WLAN Link + Earphone + NFC Tx + USB Cable (Charging from Adapter)		

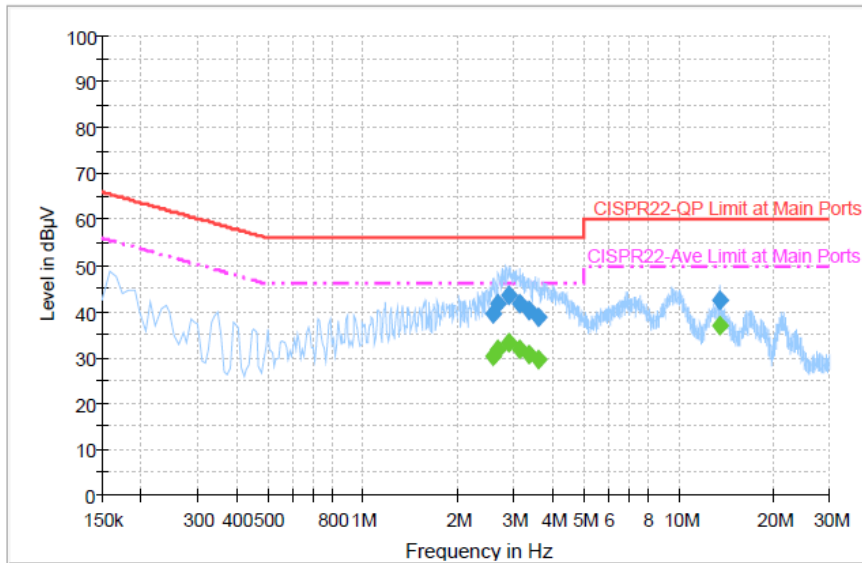

Final Result : Quasi-Peak

Frequency (MHz)	Quasi-Peak (dBµV)	Filter	Line	Corr. (dB)	Margin (dB)	Limit (dBµV)
2.582000	39.5	Off	L1	19.6	16.5	56.0
2.686000	41.5	Off	L1	19.5	14.5	56.0
2.910000	43.4	Off	L1	19.6	12.6	56.0
3.142000	41.7	Off	L1	19.6	14.3	56.0
3.358000	40.3	Off	L1	19.6	15.7	56.0
3.606000	38.7	Off	L1	19.6	17.3	56.0
13.558000	42.6	Off	L1	19.8	17.4	60.0

Final Result : Average

Frequency (MHz)	Average (dBµV)	Filter	Line	Corr. (dB)	Margin (dB)	Limit (dBµV)
2.582000	30.3	Off	L1	19.6	15.7	46.0
2.686000	31.6	Off	L1	19.5	14.4	46.0
2.910000	33.3	Off	L1	19.6	12.7	46.0
3.142000	31.9	Off	L1	19.6	14.1	46.0
3.358000	30.8	Off	L1	19.6	15.2	46.0
3.606000	29.4	Off	L1	19.6	16.6	46.0
13.558000	37.0	Off	L1	19.8	13.0	50.0



Final Test Date	Apr. 12, 2014	Test Site No.	CO05-HY
Temperature	20~22°C	Humidity	46~48%
Test Engineer	Cosmo Xu	Configuration	Transmitting Mode (13.56MHz)
		Phase	Neutral
Mode	GSM850 Idle + Bluetooth Link + WLAN Link + Earphone + NFC Tx + USB Cable (Charging from Adapter)		

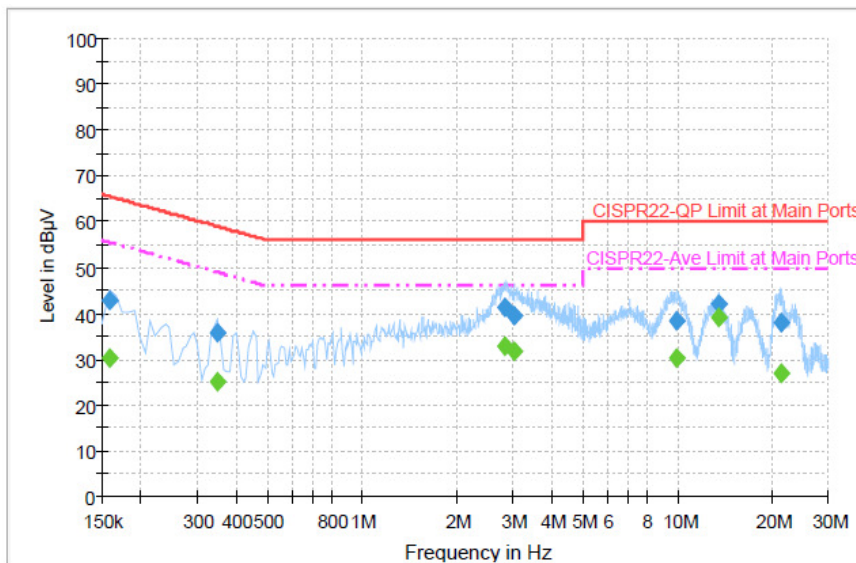

Final Result : Quasi-Peak

Frequency (MHz)	Quasi-Peak (dBµV)	Filter	Line	Corr. (dB)	Margin (dB)	Limit (dBµV)
0.158000	42.7	Off	N	19.3	22.9	65.6
0.350000	35.9	Off	N	19.4	23.1	59.0
2.822000	41.3	Off	N	19.6	14.7	56.0
3.038000	39.6	Off	N	19.6	16.4	56.0
9.950000	38.5	Off	N	19.7	21.5	60.0
13.558000	42.2	Off	N	19.9	17.8	60.0
21.286000	38.1	Off	N	20.0	21.9	60.0

Final Result : Average

Frequency (MHz)	Average (dBµV)	Filter	Line	Corr. (dB)	Margin (dB)	Limit (dBµV)
0.158000	30.2	Off	N	19.3	25.4	55.6
0.350000	25.2	Off	N	19.4	23.8	49.0
2.822000	32.8	Off	N	19.6	13.2	46.0
3.038000	31.8	Off	N	19.6	14.2	46.0
9.950000	30.3	Off	N	19.7	19.7	50.0
13.558000	39.2	Off	N	19.9	10.8	50.0
21.286000	27.0	Off	N	20.0	23.0	50.0



2.2 Field Strength of Fundamental Emissions and Mask Measurement

2.2.1 Limit

Field strength of fundamental emissions limit:

The field strength of fundamental emissions shall not exceed 15848 microvolts/meter at 30 meters.

The emissions limit in this paragraph is based on measurement instrumentation employing a QP detector.

Frequencies (MHz)	Field Strength (microvolts/meter)	Field Strength (dBµV/m) at 10m	Field Strength (dBµV/m) at 3m
13.553 ~ 13.567MHz	15848 at 30m	103.08 (QP)	124 (QP)

Mask limit:

Rules and specifications	CFR 47 Part 15 section 15.225(a)-(d)				
Description	Compliance with the spectrum mask is tested using a spectrum analyzer with RBW set to a 9kHz for the band 13.553~13.567MHz				
Limit	Freq. of Emission (MHz)	Field Strength (µV/m) at 30m	Field Strength (dBµV/m) at 30m	Field Strength (dBµV/m) at 10m	Field Strength (dBµV/m) at 3m
	1.705~13.110	30	29.5	48.58	69.5
	13.110~13.410	106	40.5	59.58	80.5
	13.410~13.553	334	50.5	69.58	90.5
	13.553~13.567	15848	84.0	103.08	124.0
	13.567~13.710	334	50.5	69.58	90.5
	13.710~14.010	106	40.5	59.58	80.5
	14.010~30.000	30	29.5	48.58	69.5



2.2.2 Measuring Instruments and Setting

Please refer to section 4 of equipments list in this report. The following table is the setting of the receiver.

Receiver Parameter	Setting
Attenuation	Auto
Center Frequency	Fundamental Frequency
RBW	9 kHz
Detector	QP

2.2.3 Test Procedures

1. Configure the EUT according to ANSI C63.4. The EUT was placed on the top of the turntable 0.8 meter above ground. The phase center of the loop receiving antenna mounted antenna tower was placed 3 meters far away from the turntable.
2. Power on the EUT and all the supporting units. The turntable was rotated by 360 degrees to determine the position of the highest radiation.
3. The height of the receiving antenna was fixed at one meter above ground to find the maximum emissions field strength.
4. For Fundamental emissions, use the receiver to measure QP reading.
5. When the radiated emissions limits are expressed in terms of the average value of the emissions, and pulsed operation is employed, the measurement field strength shall be determined by averaging over one complete pulse train, including blanking intervals, as long as the pulse train does not exceed 0.1 seconds. As an alternative (provided the transmitter operates for longer than 0.1 seconds) or in cases where the pulse train exceeds 0.1 seconds, the measured field strength shall be determined from the average absolute voltage during a 0.1 second interval during which the field strength is at its maximum value.
6. Compliance with the spectrum mask is tested using a spectrum analyzer with RBW set to a 9kHz for the band 13.553~13.567MHz.

2.2.4 Test Setup Layout

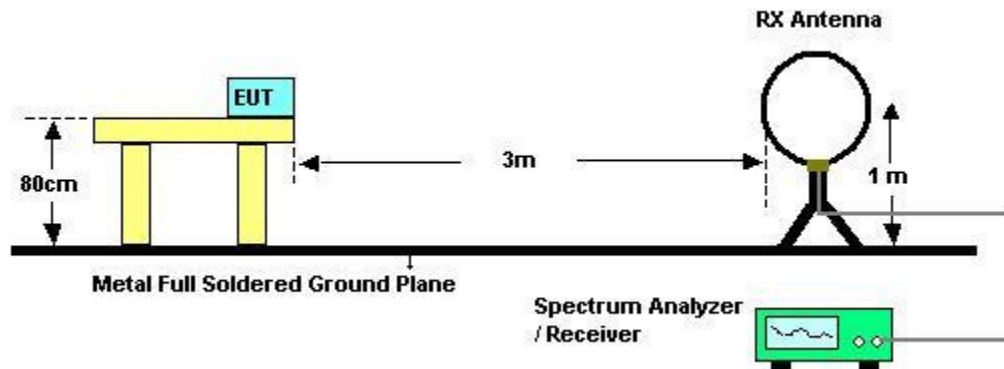

2.2.5 Test Deviation

There is no deviation with the original standard.



2.2.6 Test Result of Field Strength of Fundamental Emissions

Final Test Date	Apr. 19, 2014	Test Site No.	03CH07-HY
Temperature	19~21°C	Humidity	44~46%
Test Engineer	Eric Shih	Configurations	Ch. 1
		Polarization	Horizontal

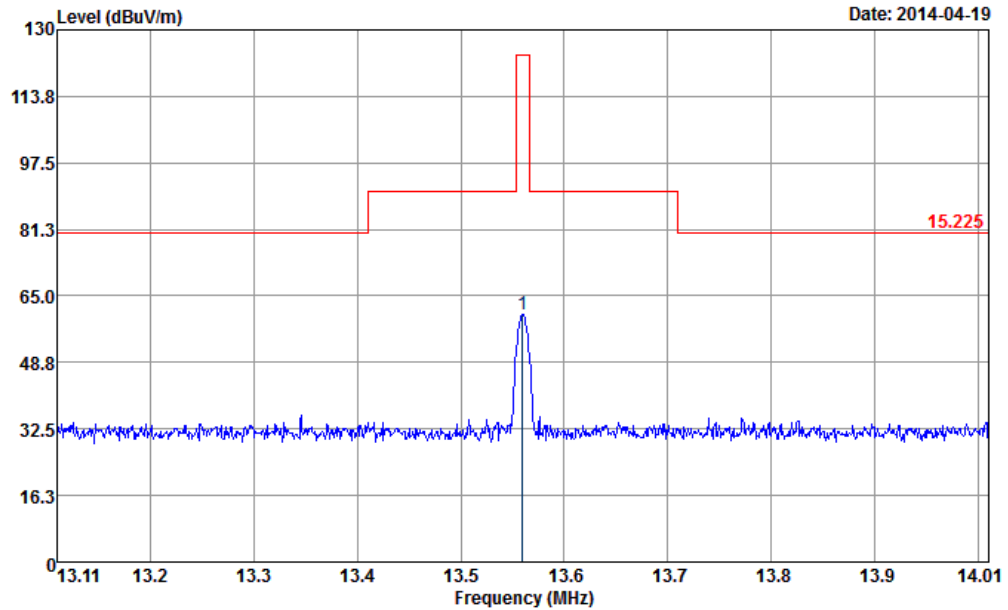

Site : 03CH07-HY
 Condition : 15.225 3m NFC FACTOR(120912)-H HORIZONTAL

	Freq	Level	Over Limit	Limit Line	ReadAntenna Level	Cable Factor	A/Pos	T/Pos	Remark
	MHz	dBuV/m	dB	dBuV/m	dBuV	dB/m	dB	cm	deg
1	13.56	60.47	-63.53	124.00	40.32	19.75	0.40	100	2 QP



Final Test Date	Apr. 19, 2014	Test Site No.	03CH07-HY
Temperature	19~21°C	Humidity	44~46%
Test Engineer	Eric Shih	Configurations	Ch. 1
		Polarization	Vertical

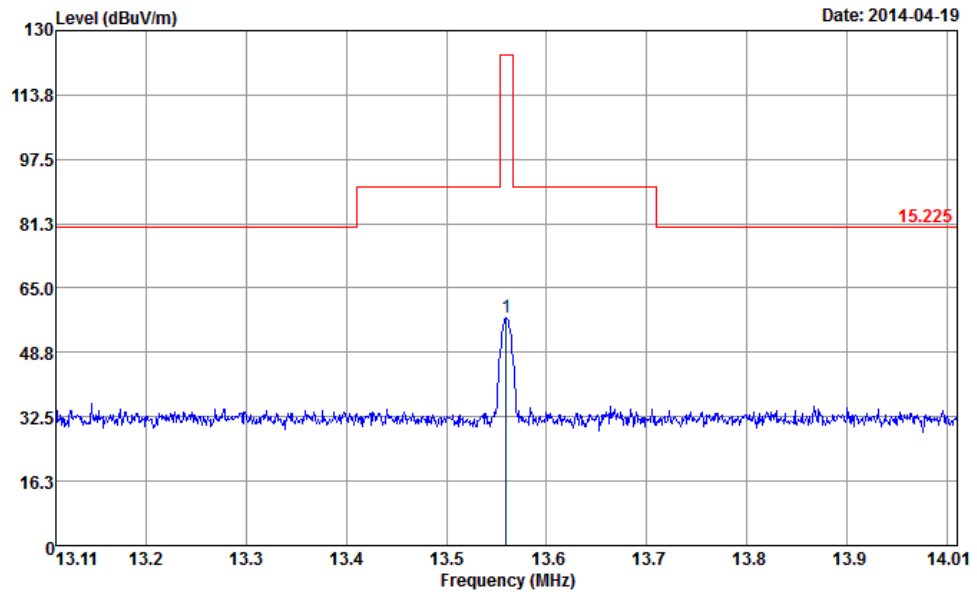

Site : 03CH07-HY
 Condition : 15.225 3m NFC FACTOR(120912)-V VERTICAL

Freq	Level	Over Limit	Limit Line	Read Level	Antenna Factor	Cable Loss	A/Pos	T/Pos	Remark
MHz	dBuV/m	dB	dBuV/m	dBuV	dB/m	dB	cm	deg	
1	13.56	57.68	-66.32	124.00	37.53	19.75	0.40	100	92 QP

Note:

1. Emission level (dBµV/m) = 20 log Emission level (µV/m).
2. Measured distance is 3m.

2.3 20dB Spectrum Bandwidth Measurement

2.3.1 Limit

Intentional radiators must be designed to ensure that the 20 dB bandwidth of the emissions in the specific band (13.553 ~ 13.567MHz).

2.3.2 Measuring Instruments and Setting

Please refer to section 4 of equipments list in this report. The following table is the setting of the spectrum analyzer.

Spectrum Parameters	Setting
Attenuation	Auto
Span Frequency	> 20dB Bandwidth
RBW	1 kHz
VBW	3 kHz
Detector	Peak
Trace	Max Hold
Sweep Time	Auto

2.3.3 Test Procedures

1. The transmitter output (antenna port) was connected to the spectrum analyzer in peak hold mode.
2. The resolution bandwidth of 1 kHz and the video bandwidth of 3 kHz were used.
3. Measured the spectrum width with power higher than 20dB below carrier.

2.3.4 Test Setup Layout

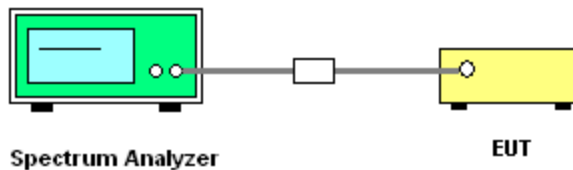

2.3.5 Test Deviation

There is no deviation with the original standard.



2.3.6 Test Result of 20dB Spectrum Bandwidth

Final Test Date	Apr. 19, 2014	Test Site No.	TH02-HY
Temperature	22~24°C	Humidity	53~55%
Test Engineer	Tommy Lee	Configurations	Ch. 1

Frequency	20dB BW (kHz)	99% OBW (kHz)	Frequency range (MHz) $f_L > 13.553\text{MHz}$	Frequency range (MHz) $f_H < 13.567\text{MHz}$	Test Result
13.56 MHz	2.640	2.240	13.55898	13.56162	Complies

20 dB / 99% Bandwidth Plot on 13.56 MHz

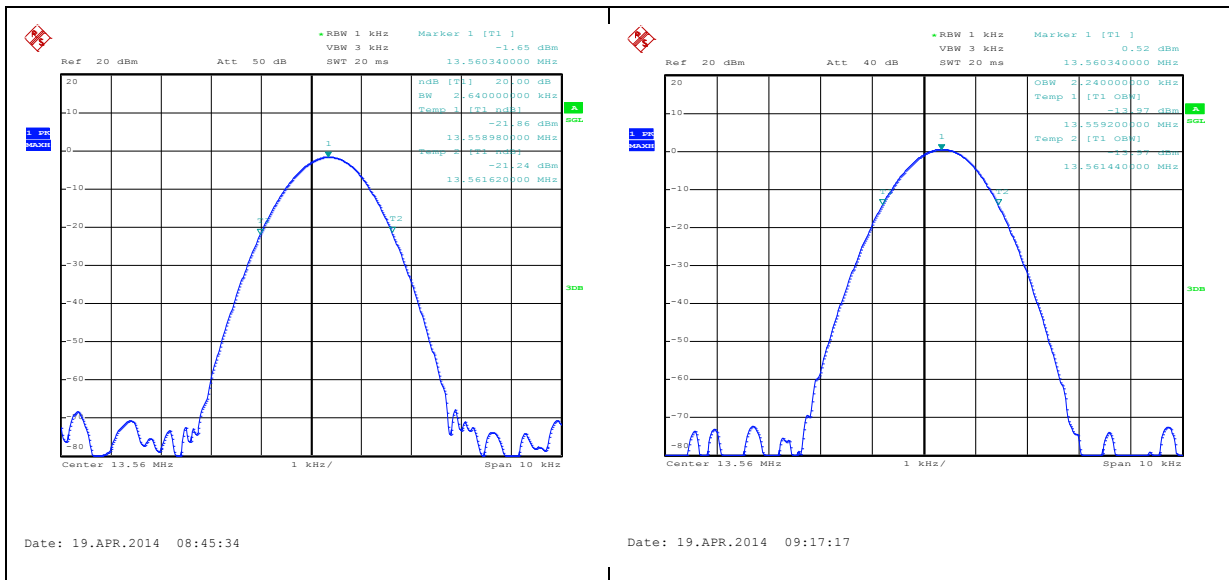

2.4 Radiated Emissions Measurement

2.4.1 Limit

The field strength of any emissions which appear outside of 13.553 ~ 13.567MHz band shall not exceed the general radiated emissions limits.

Frequencies (MHz)	Field Strength (μV/m)	Measurement Distance (meters)
0.009~0.490	2400/F(kHz)	300
0.490~1.705	24000/F(kHz)	30
1.705~30.0	30	30
30~88	100	3
88~216	150	3
216~960	200	3
Above 960	500	3

2.4.2 Measuring Instruments and Setting

Please refer to section 4 of equipment list in this report. The following table is the setting of receiver.

Receiver Parameter	Setting
Attenuation	Auto
Start ~ Stop Frequency	9kHz~150kHz / RBW 200Hz for QP
Start ~ Stop Frequency	150kHz~30MHz / RBW 9kHz for QP
Start ~ Stop Frequency	30MHz~1000MHz / RBW 120kHz for Peak

Note: The emission limits shown in the above table are based on measurements employing a CISPR quasi-peak detector except for the frequency bands 9-90 kHz, 110-490 kHz. Radiated emission limits in these two bands are based on measurements employing an average detector.



2.4.3 Test Procedures

1. Configure the EUT according to ANSI C63.4. The EUT was placed on the top of the turntable 0.8 meter above ground. The phase center of the receiving antenna mounted on the top of a height-variable antenna tower was placed 3 meters far away from the turntable.
2. Power on the EUT and all the supporting units. The turntable was rotated by 360 degrees to determine the position of the highest radiation.
3. The height of the broadband receiving antenna was varied between one meter and four meters above ground to find the maximum emissions field strength of both horizontal and vertical polarization.
4. For each suspected emissions, the antenna tower was scan (from 1 M to 4 M) and then the turntable was rotated (from 0 degree to 360 degrees) to find the maximum reading.
5. Set the test-receiver system to Peak or CISPR quasi-peak Detect Function with specified bandwidth under Maximum Hold Mode.
6. When the radiated emissions limits are expressed in terms of the average value of the emissions, and pulsed operation is employed, the measurement field strength shall be determined by averaging over one complete pulse train, including blanking intervals, as long as the pulse train does not exceed 0.1 seconds. As an alternative (provided the transmitter operates for longer than 0.1 seconds) or in cases where the pulse train exceeds 0.1 seconds, the measured field strength shall be determined from the average absolute voltage during a 0.1 second interval during which the field strength is at its maximum value.
7. In case the emission is lower than 30MHz, loop antenna has to be used for measurement and the recorded data should be QP measured by receiver. High – Low scan is not required in this case.

2.4.4 Test Setup Layout

For radiated emissions below 30MHz

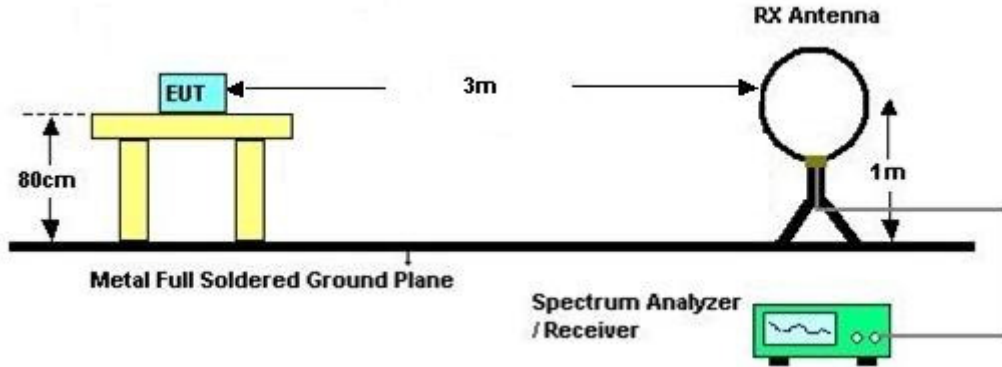

For radiated emissions above 30MHz

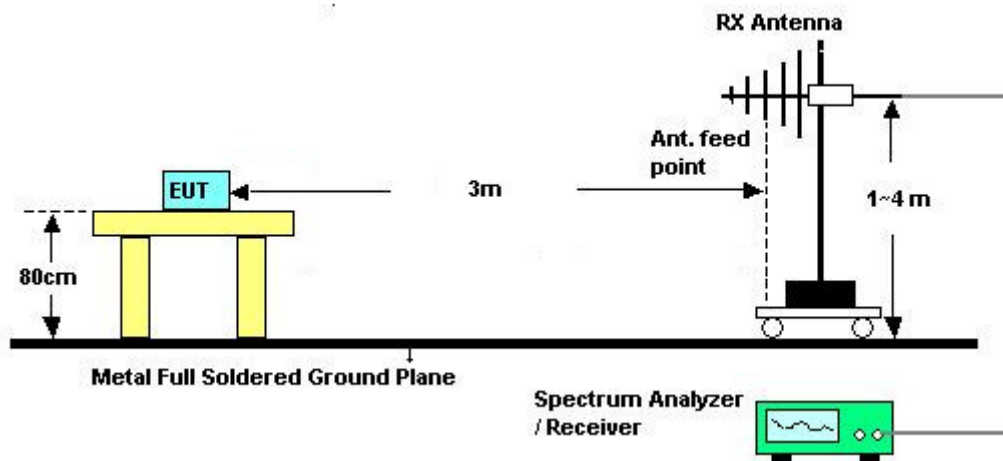

2.4.5 Test Deviation

There is no deviation with the original standard.



2.4.6 Results of Radiated Emissions (9 kHz~30MHz)

Final Test Date	Apr. 19, 2014	Test Site No.	03CH07-HY
Temperature	19~21°C	Humidity	44~46%
Test Engineer	Eric Shih	Configurations	Ch. 1
		Polarization	Horizontal

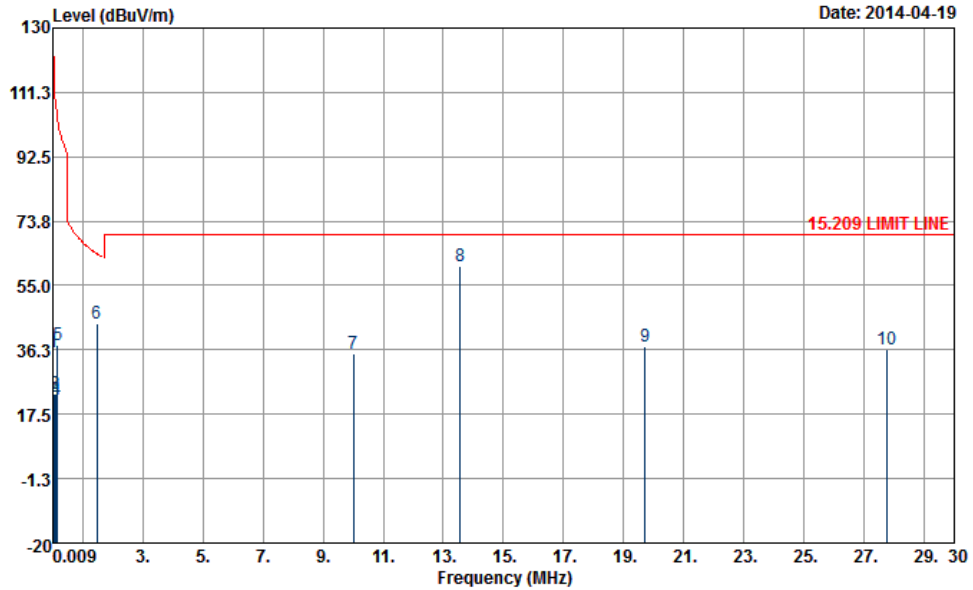

Site : 03CH07-HY
 Condition : 15.209 LIMIT LINE 3m NFC FACTOR(120912)-H HORIZONTAL

	Freq	Level	Over Limit	Limit Line	ReadAntenna	Cable	A/Pos	T/Pos	Remark
	MHz	dBuV/m	dB	dBuV/m	dBuV	dB/m	dB	cm	deg
1	0.02	35.46	-87.03	122.49	14.91	20.26	0.29	---	---
2	0.07	23.39	-87.66	111.05	2.99	20.11	0.29	---	Average
3	0.10	23.39	-84.55	107.94	3.03	20.07	0.29	---	QP
4	0.14	21.83	-82.65	104.48	1.48	20.06	0.29	---	Average
5	0.16	37.84	-65.47	103.31	17.51	20.04	0.29	---	Average
6	1.48	44.08	-20.11	64.19	23.76	20.01	0.31	100	13 QP
7	10.01	35.02	-34.98	70.00	14.88	19.75	0.39	---	QP
8	13.56	60.53			40.38	19.75	0.40	---	QP
9	19.71	37.42	-32.58	70.00	16.88	20.11	0.43	---	QP
10	27.76	36.33	-33.67	70.00	15.48	20.35	0.50	---	QP

Note:

1. Remark 8 is transmitter's fundamental signal which is higher than any other spurious emissions.
2. The amplitude of spurious emissions which are attenuated by more than 20dB below the permissible value has no need to be reported.

Distance extrapolation factor = 40 log (specific distance / test distance) (dB);

Limit line = specific limits (dBuV) + distance extrapolation factor.



Final Test Date	Apr. 19, 2014	Test Site No.	03CH07-HY
Temperature	19~21°C	Humidity	44~46%
Test Engineer	Eric Shih	Configurations	Ch. 1
		Polarization	Vertical

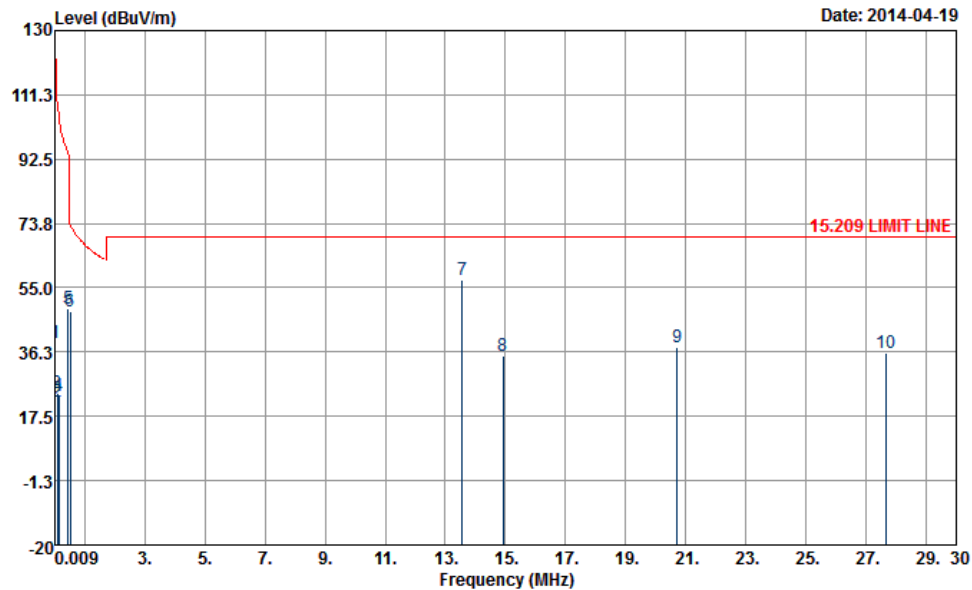

Site : 03CH07-HY
 Condition : 15.209 LIMIT LINE 3m NFC FACTOR(120912)-V VERTICAL

	Freq	Level	Over	Limit	ReadAntenna	Cable	A/Pos	T/Pos	Remark	
	MHz	dBuV/m	dB	dBuV/m	dBuV	dB/m	dB	cm	deg	
1	0.01	39.06	-86.21	125.27	18.51	20.26	0.29	---	---	Average
2	0.08	21.65	-87.81	109.46	1.25	20.11	0.29	---	---	Average
3	0.10	24.34	-83.31	107.65	3.98	20.07	0.29	---	---	QP
4	0.13	23.26	-82.15	105.41	2.91	20.06	0.29	---	---	Average
5	0.45	49.13	-45.49	94.62	28.84	20.00	0.29	---	---	Average
6	0.51	48.06	-25.35	73.41	27.75	20.00	0.31	100	---	309 QP
7	13.56	57.31			37.16	19.75	0.40	---	---	QP
8	14.92	35.24	-34.76	70.00	15.07	19.76	0.41	---	---	QP
9	20.73	37.53	-32.47	70.00	16.89	20.21	0.43	---	---	QP
10	27.67	35.86	-34.14	70.00	15.00	20.36	0.50	---	---	QP

Note:

1. Remark 7 is transmitter's fundamental signal which is higher than any other spurious emissions.
2. The amplitude of spurious emissions which are attenuated by more than 20dB below the permissible value has no need to be reported.
 1. Distance extrapolation factor = 40 log (specific distance / test distance) (dB);
 2. Limit line = specific limits (dBμV) + distance extrapolation factor.



2.4.7 Results for Radiated Emissions (30MHz~1GHz)

Final Test Date	Apr. 19, 2014	Test Site No.	03CH07-HY
Temperature	19~21°C	Humidity	44~46%
Test Engineer	Eric Shih	Configurations	Ch. 1
		Polarization	Horizontal

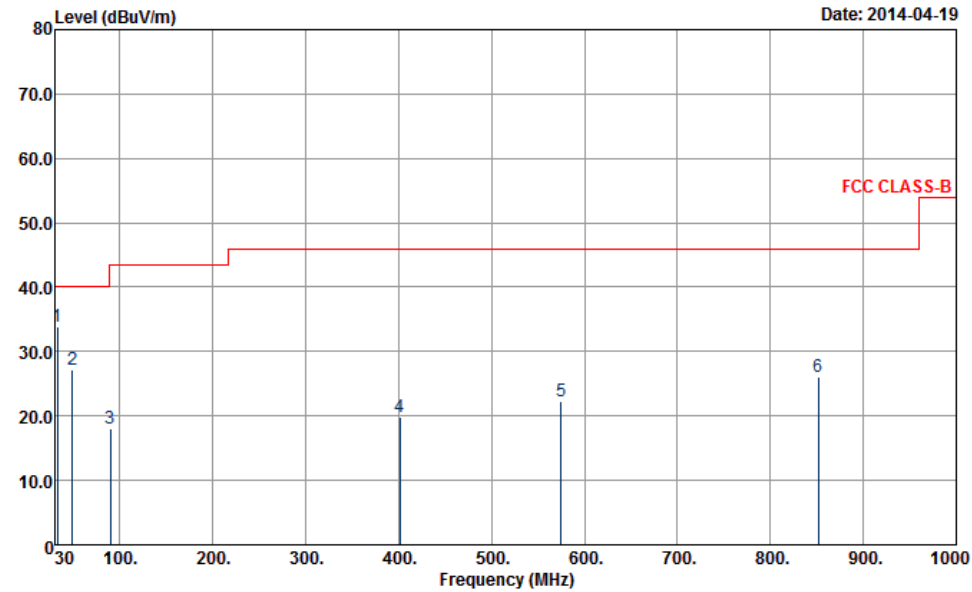

Site : 03CH07-HY
 Condition : FCC CLASS-B 3m LF-ANT(131102) HORIZONTAL

	Freq	Level	Over	Limit	ReadAntenna	Cable	Preamp	A/Pos	T/Pos	Remark
	MHz	dBuV/m	Limit	Line	Level	Factor	Loss	Factor	cm	deg
			dB	dBuV/m	dBuV	dB/m	dB	dB		
1	32.43	33.98	-6.02	40.00	47.56	17.24	0.56	31.38	138	37 Peak
2	48.63	27.13	-12.87	40.00	48.55	9.10	0.68	31.20	---	---
3	89.94	17.97	-25.53	43.50	39.43	8.70	0.94	31.10	---	---
4	401.50	19.94	-26.06	46.00	32.74	15.95	2.15	30.90	---	---
5	575.10	22.38	-23.62	46.00	30.81	19.65	2.62	30.70	---	---
6	851.60	26.17	-19.83	46.00	30.02	23.28	3.27	30.40	---	---



Final Test Date	Apr. 19, 2014	Test Site No.	03CH07-HY
Temperature	19~21°C	Humidity	44~46%
Test Engineer	Eric Shih	Configurations	Ch. 1
		Polarization	Vertical

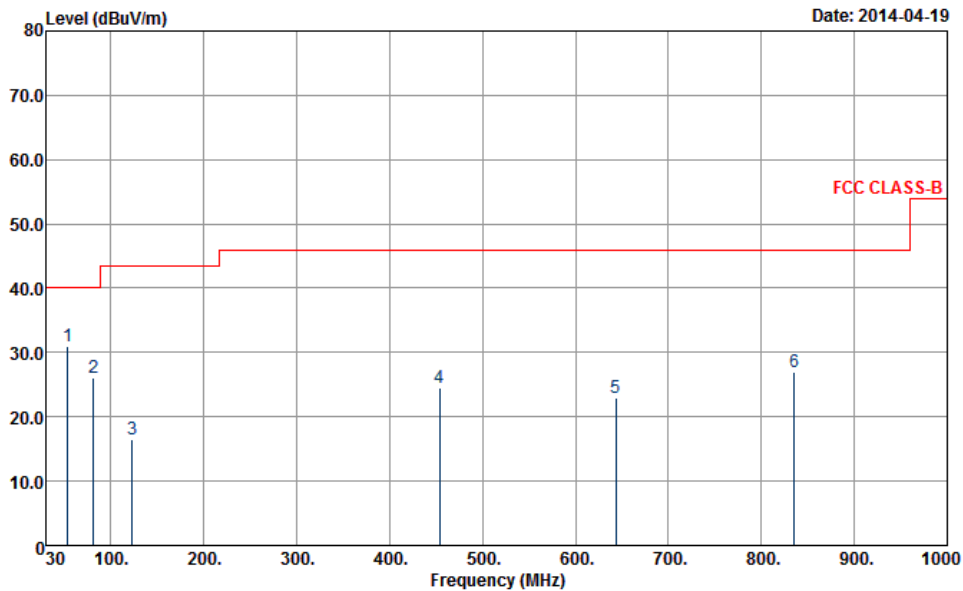

Site : 03CH07-HY
 Condition : FCC CLASS-B 3m LF-ANT(131102) VERTICAL

	Freq	Level	Over	Limit	Read	Antenna	Cable	Preamp	A/Pos	T/Pos	Remark
	MHz	dBuV/m	dB	dBuV/m	dBuV	dB/m	dB	dB	cm	deg	
1	53.49	31.04	-8.96	40.00	54.32	7.20	0.72	31.20	105	143	Peak
2	81.30	26.12	-13.88	40.00	49.18	7.22	0.89	31.17	---	---	Peak
3	122.88	16.55	-26.95	43.50	35.01	11.52	1.12	31.10	---	---	Peak
4	454.00	24.41	-21.59	46.00	35.53	17.34	2.31	30.77	---	---	Peak
5	643.70	23.06	-22.94	46.00	30.35	20.40	2.82	30.51	---	---	Peak
6	835.50	27.03	-18.97	46.00	31.17	23.00	3.23	30.37	---	---	Peak

Note:

1. The amplitude of spurious emissions which are attenuated by more than 20dB below the permissible value has no need to be reported.
2. Emission level (dBμV/m) = 20 log Emission level (μV/m).
3. Corrected Reading: Antenna Factor + Cable Loss + Read Level - Preamp Factor= Level.



2.5 Frequency Stability Measurement

2.5.1 Limit

The frequency tolerance of the carrier signal shall be maintained within +/- 0.01% (100ppm) of the operating frequency over a temperature variation of -20 degrees to +50 degrees C at normal supply voltage, and for a variation in the primary supply voltage from 85% to 115% of the rated supply voltage at a temperature of 20 degrees C. For battery operated equipment, the equipment tests shall be performed using a new battery.

2.5.2 Measuring Instruments and Setting

Please refer to section 4 of equipment list in this report. The following table is the setting of the spectrum analyzer.

Spectrum Parameter	Setting
Attenuation	Auto
RBW	1 kHz
VBW	3 kHz
Sweep Time	Auto

2.5.3 Test Procedures

1. The transmitter output (antenna port) was connected to the spectrum analyzer.
2. EUT have transmitted signal and fixed channelize
3. Set the spectrum analyzer span to view the entire emissions bandwidth.
4. Set RBW = 1 kHz, VBW = 3 kHz with peak detector and maxhold settings.
5. The f_c is declaring of channel frequency. Then the frequency error formula is $(f_c-f)/f_c \times 10^6$ ppm and the limit is less than ± 100 ppm.
6. Extreme temperature rule is -20°C~50°C.

2.5.4 Test Setup Layout

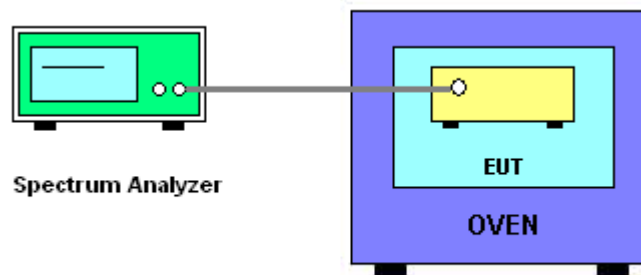

2.5.5 Test Deviation

There is no deviation with the original standard.



2.5.6 Test Result of Frequency Stability

Final Test Date	Apr. 19, 2014	Test Site No.	TH02-HY
Temperature	22~24°C	Humidity	53~55%
Test Engineer	Tommy Lee	Configurations	Ch. 1

Voltage vs. Frequency Stability

Voltage(V)	Measurement Frequency (MHz)
120	13.560310
102	13.560320
138	13.560300
Max. Deviation (MHz)	0.000320
Max. Deviation (ppm)	23.5988

Temperature vs. Frequency Stability

Temperature (°C)	Measurement Frequency (MHz)
-20	13.560380
-10	13.560360
0	13.560350
10	13.560360
20	13.560330
30	13.560300
40	13.560280
50	13.560290
Max. Deviation (MHz)	0.000380
Max. Deviation (ppm)	28.0236



2.6 Antenna Requirements

2.6.1 Limit

Except for special regulations, the Low-power Radio-frequency Devices must not be equipped with any jacket for installing an antenna with extension cable. An intentional radiator shall be designed to ensure that no antenna other than that furnished by the responsible party shall be used with the device. The use of a permanently attached antenna or of an antenna that uses a unique coupling to the intentional radiator shall be considered sufficient to comply with the provisions of this Section. The manufacturer may design the unit so that the user can replace a broken antenna, but the use of a standard antenna jack or electrical connector is prohibited.

2.6.2 Antenna Connector Construction

Embedded in Antenna.



3. LIST OF MEASURING EQUIPMENT

Instrument	Manufacturer	Model No.	Serial No.	Characteristics	Calibration Date	Test Date	Due Date	Remark
Spectrum Analyzer	Rohde & Schwarz	FSP40	100055	9kHz~40GHz	Jun. 07, 2013	Apr. 19, 2014	Jun. 06, 2014	Conducted (TH02-HY)
Thermal Chamber	Ten Billion	TTH-D3SP	TBN-930701	N/A	Jul. 19, 2013	Apr. 19, 2014	Jul. 18, 2014	Conducted (TH02-HY)
Hygrometer	Testo	608-H1	34897199	N/A	May 07, 2013	Apr. 19, 2014	May 06, 2014	Conducted (TH02-HY)
RF cable	WOKEN	SMA(M)-SM A(M) for SS405	S05-130703-32	N/A	Jul. 09, 2013	Apr. 19, 2014	Jul. 08, 2014	Conducted (TH02-HY)
EMI Test Receiver	Rohde & Schwarz	ESCS 30	100356	9kHz ~ 2.75GHz	Nov. 15, 2013	Apr. 12, 2014	Nov. 14, 2014	Conduction (CO05-HY)
LISN (for auxiliary equipment)	Rohde & Schwarz	ENV216	100081	9kHz ~ 30MHz	Dec. 12, 2013	Apr. 12, 2014	Dec. 11, 2014	Conduction (CO05-HY)
LISN	Rohde & Schwarz	ENV216	100080	9kHz ~ 30MHz	Dec. 04, 2013	Apr. 12, 2014	Dec. 03, 2014	Conduction (CO05-HY)
AC Power Source	ChainTek	APC-1000W	N/A	N/A	N/A	Apr. 12, 2014	N/A	Conduction (CO05-HY)
Thermometer	Testo	608-H1	34913912	N/A	Apr. 26, 2013	Apr. 12, 2014	Apr. 25, 2014	Conduction (CO05-HY)
Test Software	N/A	EMC32	8.40.0	N/A	N/A	Apr. 12, 2014	N/A	Conduction (CO05-HY)
LF Cable	Shuner	RG-402	N/A	N/A	Oct. 17, 2013	Apr. 12, 2014	Oct. 16, 2014	Conduction (CO05-HY)
EMI Test Receiver	Rohde & Schwarz	ESCI 7	100724	9kHz~7GHz	Sep. 06, 2013	Apr. 19, 2014	Sep. 05, 2014	Radiation (03CH07-HY)
Spectrum Analyzer	Rohde & Schwarz	FSV30	101749	10Hz ~ 30GHz	Feb. 10, 2014	Apr. 19, 2014	Feb. 09, 2015	Radiation (03CH07-HY)
Loop Antenna	Rohde & Schwarz	HFH2-Z2	860004/0001	9 kHz~30 MHz	Jul. 03, 2012	Apr. 19, 2014	Jul. 02, 2014	Radiation (03CH07-HY)
Bilog Antenna	Schaffner	CBL6111C	2726	30MHz ~ 1GHz	Oct. 10, 2013	Apr. 19, 2014	Oct. 09, 2014	Radiation (03CH07-HY)
Preamplifier	COM-POWER	PA-103A	161241	10 MHz ~ 1000MHz	Mar. 17, 2014	Apr. 19, 2014	Mar. 16, 2015	Radiation (03CH07-HY)
Turn Table	ChainTek	ChainTek 3000	N/A	0 ~ 360 degree	N/A	Apr. 19, 2014	N/A	Radiation (03CH07-HY)
Antenna Mast	ChainTek	ChainTek 3000	N/A	N/A	N/A	Apr. 19, 2014	N/A	Radiation (03CH07-HY)
LF RF Cable	Warison+HUB ER SUHNER	WCBA-WC0 4NM.NM2	N/A	30MHz ~ 1GHz	Nov. 28, 2013	Apr. 19, 2014	Nov. 27, 2014	Radiation (03CH07-HY)
Test Software	Audix	E3	Version 6.2009-08-24	N/A	N/A	Apr. 19, 2014	N/A	Radiation (03CH07-HY)
Hygrometer	Testo	608-H1	34897197	N/A	May 07, 2013	Apr. 19, 2014	May 06, 2014	Radiation (03CH07-HY)

Note: Test equipment calibration is traceable to the procedure of ISO17025.



4. TEST LOCATION

HWA YA	ADD : No. 52, Hwa Ya 1st Rd., Kwei-Shan Hsiang, Tao Yuan Hsien, Taiwan, R.O.C.
	TEL : 886-3-327-3456
	FAX : 886-3-318-0055