



FCC/IC RF Test Report

APPLICANT : Sony Mobile Communications AB
EQUIPMENT : Smart phone
BRAND NAME : SONY
MODEL NAME : D2104
TYPE NAME : PM-0673-BV
FCC ID : PY7PM-0673
IC : 4170B-PM0673
STANDARD : FCC 47 CFR Part 2, 22(H), 24(E)
IC RSS-132 issue 3 and RSS-133 issue 6
IC RSS-GEN issue 3
CLASSIFICATION : PCS Licensed Transmitter Held to Ear (PCE)

The product was received on Oct. 29, 2013 and testing was completed on Dec. 03, 2013. We, SPORTON INTERNATIONAL INC., would like to declare that the tested sample has been evaluated in accordance with the procedures given in ANSI / TIA / EIA-603-C-2004 and shown to be compliant with the applicable technical standards.

The test results in this report apply exclusively to the tested model / sample. Without written approval of SPORTON INTERNATIONAL INC., the test report shall not be reproduced except in full.

Reviewed by: Joseph Lin / Supervisor

Approved by: Jones Tsai / Manager



SPORTON INTERNATIONAL INC.

No. 52, Hwa Ya 1st Rd., Hwa Ya Technology Park, Kwei-Shan Hsiang, Tao Yuan Hsien, Taiwan, R.O.C.

SPORTON INTERNATIONAL INC.

TEL : 886-3-327-3456

FAX : 886-3-328-4978

FCC ID : PY7PM-0673

IC : 4170B-PM0673

Page Number : 1 of 168

Report Issued Date : Jan. 08, 2014

Report Version : Rev. 03



TABLE OF CONTENTS

REVISION HISTORY..... 3

SUMMARY OF TEST RESULT 4

1 GENERAL DESCRIPTION 5

 1.1 Applicant..... 5

 1.2 Manufacturer 5

 1.3 Feature of Equipment Under Test..... 5

 1.4 Product Specification of Equipment Under Test 6

 1.5 Modification of EUT 6

 1.6 Maximum ERP/EIRP Power, Frequency Tolerance, and Emission Designator 7

 1.7 Testing Site..... 7

 1.8 Applied Standards 8

2 TEST CONFIGURATION OF EQUIPMENT UNDER TEST 9

 2.1 Test Mode..... 9

 2.2 Connection Diagram of Test System 12

 2.3 Support Unit used in test configuration and system..... 12

 2.4 Measurement Results Explanation Example 12

3 TEST RESULT..... 13

 3.1 Conducted Output Power Measurement..... 13

 3.2 Peak-to-Average Ratio 15

 3.3 Effective Radiated Power and Effective Isotropic Radiated Power Measurement 29

 3.4 99% Occupied Bandwidth and 26dB Bandwidth Measurement..... 35

 3.5 Band Edge Measurement..... 55

 3.6 Conducted Spurious Emission Measurement 68

 3.7 Field Strength of Spurious Radiation Measurement 123

 3.8 Frequency Stability Measurement..... 161

4 LIST OF MEASURING EQUIPMENT 166

5 UNCERTAINTY OF EVALUATION 168



SUMMARY OF TEST RESULT

Report Section	FCC Rule	IC Rule	Description	Limit	Result	Remark
3.1	§2.1046	RSS-132 (5.4) RSS-133 (6.4)	Conducted Output Power	N/A	PASS	-
3.2	§24.232(d)	RSS-132 (5.4) RSS-133(6.4)	Peak-to-Average Ratio	< 13 dB	PASS	-
3.3	§22.913(a)(2)	RSS-132(5.4) SRSP-503(5.1.3)	Effective Radiated Power	< 7 Watts	PASS	-
3.3	§24.232(c)	RSS-133 (6.4) SRSP-510(5.1.2)	Equivalent Isotropic Radiated Power	< 2 Watts	PASS	-
3.4	§2.1049 §22.917(a) §24.238(b)	RSS-GEN(4.6.1) RSS-133(2.3)	99% and 26dB Occupied Bandwidth	N/A	PASS	-
3.5	§2.1051 §22.917(a) §24.238(a)	RSS-132 (5.5) RSS-133 (6.5)	Band Edge Measurement	< 43+10log ₁₀ (P[Watts])	PASS	-
3.6	§2.1051 §22.917(a) §24.238(a)	RSS-132 (5.5) RSS-133 (6.5)	Conducted Spurious Emission	< 43+10log ₁₀ (P[Watts])	PASS	-
3.7	§2.1053 §22.917(a) §24.238(a)	RSS-132 (5.5) RSS-133 (6.5)	Field Strength of Spurious Radiation	< 43+10log ₁₀ (P[Watts])	PASS	Under limit 13.23 dB at 2545.000 MHz
3.8	§2.1055 §22.355 §24.235	RSS-132(5.3) RSS-133(6.3)	Frequency Stability for Temperature & Voltage	< 2.5 ppm	PASS	-



1 General Description

1.1 Applicant

Sony Mobile Communications AB
Nya Vattentorget, 22188 Lund, Sweden

1.2 Manufacturer

Arima Communication Corp.
6F, No. 866, Jhongjheng Rd., Jhonghe Dist., New Taipei City 23586, Taiwan

1.3 Feature of Equipment Under Test

Product Feature	
Equipment	Smart phone
Brand Name	SONY
Model Name	D2104
Type Name	PM-0673-BV
FCC ID	PY7PM-0673
IC	4170B-PM0673
GSM Operating Band(s)	GSM 850/900/1800/1900MHz
WCDMA Operating Band(s)	FDD Band I / II / V
WCDMA Rel. Version	Rel. 7
GPRS / EGPRS Multi Slot Class	GPRS Class 33, EGPRS Class 33
Wi-Fi Specification	802.11b/g/n (HT20)
Bluetooth Version	v3.0+EDR / v4.0-LE
Power Supply	Battery / AC Adapter / Car Charger

Remark: The above EUT's information was declared by manufacturer. Please refer to the specifications or user's manual for more detailed description.

1.4 Product Specification of Equipment Under Test

Product Specification subjective to this standard	
Tx Frequency	GSM850: 824.2 MHz ~ 848.8 MHz GSM1900: 1850.2 MHz ~ 1909.8MHz WCDMA Band V: 826.4 MHz ~ 846.6 MHz WCDMA Band II: 1852.4 MHz ~ 1907.6 MHz
Rx Frequency	GSM850: 869.2 MHz ~ 893.8 MHz GSM1900: 1930.2 MHz ~ 1989.8 MHz WCDMA Band V: 871.4 MHz ~ 891.6 MHz WCDMA Band II: 1932.4 MHz ~ 1987.6 MHz
Maximum Output Power to Antenna	GSM850 : 32.92 dBm GSM1900 : 30.42 dBm WCDMA Band V : 23.10 dBm WCDMA Band II : 22.83 dBm
Antenna Type	PIFA Antenna
Type of Modulation	GSM: GMSK GPRS: GMSK EDGE: GMSK / 8PSK WCDMA: QPSK (Uplink) HSDPA: QPSK (Uplink) HSUPA: QPSK (Uplink)
EUT Serial Number	IMEI 1: 00440214-707851-7 IMEI 2: 00440214-707852-5 S/N : WUJ016LPBL
HW Version	A
SW Version	20.0.B.0.26
EUT Stage	Production Unit

Accessory List	
AC Adapter	Model No. : EP800
	Type No. : CAA-0002016-US B
Battery	Model No. : BA900
	Type No. : AB-0500
Earphone	Model No. : MH410c
	Type No. : AG-1100
USB Cable	Model No. : EC450
	Part No. : 1242.6715.3 12W46

1.5 Modification of EUT

No modifications are made to the EUT during all test items.



1.6 Maximum ERP/EIRP Power, Frequency Tolerance, and Emission Designator

FCC Rule	System	Type of Modulation	Maximum ERP/EIRP (W)	Frequency Tolerance (ppm)	Emission Designator
Part 22	GSM850 GSM	GMSK	0.64	0.027 ppm	248KGXW
Part 22	GSM850 EDGE class 8	8PSK	0.29	0.022 ppm	246KG7W
Part 22	WCDMA Band V RMC 12.2Kbps	QPSK	0.08	0.015 ppm	4M20F9W
Part 24	GSM1900 GPRS class 8	GMSK	1.43	0.023 ppm	248KGXW
Part 24	GSM1900 EDGE class 8	8PSK	0.45	0.018 ppm	246KG7W
Part 24	WCDMA Band II RMC 12.2Kbps	QPSK	0.18	0.009 ppm	4M18F9W

1.7 Testing Site

Test Site	SPORTON INTERNATIONAL INC.		
Test Site Location	No. 52, Hwa Ya 1 st Rd., Hwa Ya Technology Park, Kwei-Shan Hsiang, Tao Yuan Hsien, Taiwan, R.O.C. TEL: +886-3-327-3456 FAX: +886-3-328-4978		
Test Site No.	Sporton Site No.		FCC/IC Registration No.
	TH02-HY	03CH07-HY	722060/4086B-1



1.8 Applied Standards

According to the specifications of the manufacturer, the EUT must comply with the requirements of the following standards:

- ♦ FCC 47 CFR Part 2, 22(H), 24(E)
- ♦ ANSI / TIA / EIA-603-C-2004
- ♦ FCC KDB 971168 D01 Power Meas. License Digital Systems v02r01
- ♦ IC RSS-132 Issue 3
- ♦ IC RSS-133 Issue 6
- ♦ IC RSS-Gen Issue 3
- ♦ NOTICE 2012-DRS0126

Remark:

1. All test items were verified and recorded according to the standards and without any deviation during the test.
2. Per the section 2.2.3 of Notice of 2012-DRS0126, " Receivers Excluded from Industry Canada Requirements", only radiocommunication receivers operating in stand-alone mode within the band 30-960 MHz and scanner receivers are subject to Industry Canada requirements.



2 Test Configuration of Equipment Under Test

2.1 Test Mode

- a. Preliminary tests were performed in different radio applications and recorded the RF output power in the following table:

Conducted Power		Burst Average Power (dBm)					
Band		GSM850			GSM1900		
Channel		128	189	251	512	661	810
Frequency (MHz)		824.2	836.4	848.8	1850.2	1880.0	1909.8
GSM		32.59	32.66	32.92	30.31	30.17	30.29
GPRS Class 8		32.48	32.60	32.76	30.42	30.26	30.39
GPRS Class 10		29.69	29.75	29.90	27.64	27.51	27.60
GPRS Class 11		27.78	27.97	28.06	26.00	25.85	25.94
GPRS Class 33		26.56	26.67	26.89	24.61	24.48	24.58
EGPRS Class 8		26.61	26.64	26.65	26.33	26.20	26.08
EGPRS Class 10		23.96	24.05	24.08	23.62	23.55	23.31
EGPRS Class 11		22.18	22.23	22.29	22.01	21.91	21.89
EGPRS Class 33		20.87	20.95	21.01	21.13	21.02	20.95
DTM 5	GSM (GMSK, 1 Tx slot)	29.67	29.74	29.86	27.61	27.48	27.59
	GPRS (GMSK, 1 Tx slot)	29.60	29.67	29.76	27.58	27.45	27.55
DTM 9	GSM (GMSK, 1 Tx slot)	29.66	29.70	29.80	27.56	27.44	27.53
	GPRS (GMSK, 1 Tx slot)	29.57	29.63	29.71	27.54	27.42	27.51
DTM 11	GSM (GMSK, 1 Tx slot)	27.75	27.86	27.97	25.98	25.81	25.91
	GPRS (GMSK, 2 Tx slots)	27.71	27.77	24.87	25.95	25.74	25.84
DTM 5	GSM (GMSK, 1 Tx slot)	29.65	29.68	29.75	27.50	27.40	27.48
	EDGE (8PSK, 1 Tx slot)	23.85	23.98	24.01	23.55	23.48	23.28
DTM 9	GSM (GMSK, 1 Tx slot)	29.60	29.63	29.70	27.48	27.39	27.45
	EDGE (8PSK, 1 Tx slot)	23.81	24.87	23.93	23.51	23.43	23.25
DTM 11	GSM (GMSK, 1 Tx slot)	27.75	27.81	27.93	25.98	25.81	25.91
	EDGE (8PSK, 2 Tx slots)	22.14	22.15	22.21	21.96	21.88	21.85



Conducted Power	Burst Average Power (dBm)					
	WCDMA Band V			WCDMA Band II		
Band						
Channel	4132	4182	4233	9262	9400	9538
Frequency (MHz)	826.4	836.4	846.6	1852.4	1880.0	1907.6
RMC 12.2K	23.04	23.08	23.10	22.52	22.83	22.64
HSDPA Subtest-1	22.15	22.18	22.23	21.80	22.11	21.93
HSDPA Subtest-2	22.12	22.16	22.20	21.75	22.06	21.89
HSDPA Subtest-3	21.64	21.68	21.73	21.24	21.53	21.45
HSDPA Subtest-4	21.62	21.66	21.70	21.20	21.50	21.42
HSUPA Subtest-1	21.98	22.00	22.05	21.64	21.82	21.60
HSUPA Subtest-2	20.70	20.73	20.78	20.61	20.89	20.74
HSUPA Subtest-3	21.14	21.20	21.24	20.92	21.19	21.05
HSUPA Subtest-4	20.61	20.79	20.88	20.64	20.93	20.76
HSUPA Subtest-5	22.03	22.05	22.10	21.82	22.00	21.79

- b. During all testing, EUT is in link mode with base station emulator at maximum power level. The spurious emission measurements were carried out in semi-anechoic chamber with 3-meter test range, and EUT was rotated on three test planes to find out the worst emission.



Frequency range investigated for radiated emission is as follows:

- 1. 30 MHz to 9000 MHz for GSM850 and WCDMA Band V.
- 2. 30 MHz to 19000 MHz for GSM1900 and WCDMA Band II.

Test Modes		
Band	Radiated TCs	Conducted TCs
GSM 850	<ul style="list-style-type: none">■ GSM Link■ EDGE class 8 Link	<ul style="list-style-type: none">■ GSM Link■ EDGE class 8 Link
GSM 1900	<ul style="list-style-type: none">■ GPRS class 8 Link■ EDGE class 8 Link	<ul style="list-style-type: none">■ GPRS class 8 Link■ EDGE class 8 Link
WCDMA Band V	<ul style="list-style-type: none">■ RMC 12.2Kbps Link	<ul style="list-style-type: none">■ RMC 12.2Kbps Link
WCDMA Band II	<ul style="list-style-type: none">■ RMC 12.2Kbps Link	<ul style="list-style-type: none">■ RMC 12.2Kbps Link

Note:

- 1. The maximum power levels are GSM or GPRS multi-slot class 8 mode for GMSK link, EDGE multi-slot class 8 mode for 8PSK link, RMC 12.2Kbps mode for WCDMA band V, and RMC 12.2Kbps mode for WCDMA band II, only these modes were used for all tests.
- 2. Because there are individual antennas for each WWAN, WLAN, and Bluetooth, the co-location test modes are not required.

2.2 Connection Diagram of Test System

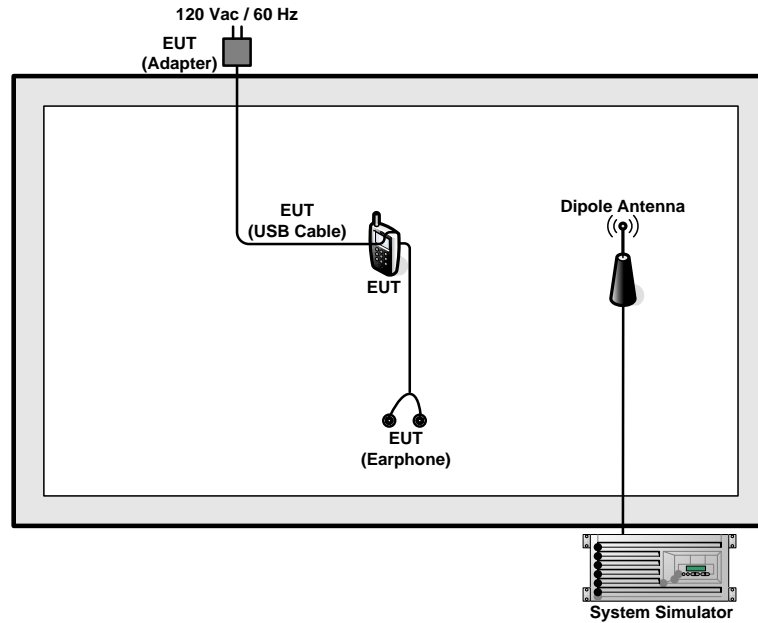

2.3 Support Unit used in test configuration and system

Equipment	Trade Name	Model No.	FCC ID	Data Cable	Power Cord
System Simulator	R&S	CMU 200	N/A	N/A	Unshielded, 1.8 m

2.4 Measurement Results Explanation Example

For all conducted test items:

The offset level is set in the spectrum analyzer to compensate the RF cable loss and attenuator factor between EUT conducted output port and spectrum analyzer. With the offset compensation, the spectrum analyzer reading level is exactly the EUT RF output level.

The spectrum analyzer offset is derived from RF cable loss and attenuator factor.

Offset = RF cable loss + attenuator factor.

Following shows an offset computation example with cable loss 4.2 dB and 10dB attenuator.

Example :

$$\begin{aligned} \text{Offset(dB)} &= \text{RF cable loss(dB)} + \text{attenuator factor(dB)} \\ &= 4.2 + 10 = 14.2 \text{ (dB)} \end{aligned}$$

3 Test Result

3.1 Conducted Output Power Measurement

3.1.1 Description of the Conducted Output Power Measurement

A base station simulator was used to establish communication with the EUT. Its parameters were set to transmit the maximum power on the EUT. The measured power in the radio frequency on the transmitter output terminals shall be reported.

3.1.2 Measuring Instruments

The measuring equipment is listed in the section 4 of this test report.

3.1.3 Test Procedures

1. The transmitter output port was connected to base station.
2. Set EUT at maximum power through base station.
3. Select lowest, middle, and highest channels for each band and different modulation.
4. Measure the maximum burst average power for GSM and maximum average power for other modulation signal.

3.1.4 Test Setup

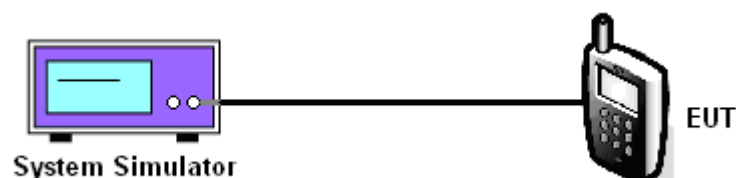

3.1.5 Test Result of Conducted Output Power

Cellular Band									
Modes	GSM850 (GSM)			GSM850 (EDGE class 8)			WCDMA Band V (RMC 12.2Kbps)		
Channel	128 (Low)	189 (Mid)	251 (High)	128 (Low)	189 (Mid)	251 (High)	4132 (Low)	4182 (Mid)	4233 (High)
Frequency (MHz)	824.2	836.4	848.8	824.2	836.4	848.8	826.4	836.4	846.6
Conducted Power (dBm)	32.59	32.66	32.92	26.61	26.64	26.65	23.04	23.08	23.10
Conducted Power (Watts)	1.82	1.85	1.96	0.46	0.46	0.46	0.20	0.20	0.20

PCS Band									
Modes	GSM1900 (GPRS class 8)			GSM1900 (EDGE class 8)			WCDMA Band II (RMC 12.2Kbps)		
Channel	512 (Low)	661 (Mid)	810 (High)	512 (Low)	661 (Mid)	810 (High)	9262 (Low)	9400 (Mid)	9538 (High)
Frequency (MHz)	1850.2	1880	1909.8	1850.2	1880	1909.8	1852.4	1880	1907.6
Conducted Power (dBm)	30.42	30.26	30.39	26.33	26.20	26.08	22.52	22.83	22.64
Conducted Power (Watts)	1.10	1.06	1.09	0.43	0.42	0.41	0.18	0.19	0.18

Note: maximum burst average power for GSM, and maximum average power for WCDMA.

3.2 Peak-to-Average Ratio

3.2.1 Description of the PAR Measurement

The peak-to-average ratio (PAR) of the transmission may not exceed 13 dB.

3.2.2 Measuring Instruments

The measuring equipment is listed in the section 4 of this test report.

3.2.3 Test Procedures

1. The EUT was connected to Spectrum Analyzer and System Simulator via power divider.
2. For GSM/EGPRS operating modes:
 - a. Set EUT in maximum power output.
 - b. Set the RBW = 1MHz, VBW = 3MHz, Peak detector in spectrum analyzer for first trace.
 - c. Set the RBW = 1MHz, VBW = 3MHz, RMS detector in spectrum analyzer for second trace.
 - d. The wanted burst signal is triggered by spectrum analyzer, and measured respectively the peak level and Mean level without burst-off time, after system simulator synchronized with the spectrum analyzer.
3. For UMTS operating modes:
 - a. Set the CCDF (Complementary Cumulative Distribution Function) option in spectrum analyzer.
 - b. The highest RF powers were measured and recorded the maximum PAPR level associated with a probability of 0.1 %.
4. Record the deviation as Peak to Average Ratio.

3.2.4 Test Setup

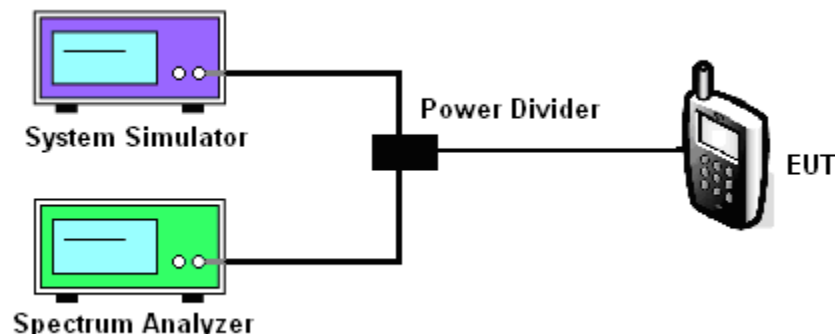

3.2.5 Test Result of Peak-to-Average Ratio

Cellular Band									
Modes	GSM850 (GSM)			GSM850 (EDGE class 8)			WCDMA Band V (RMC 12.2Kbps)		
Channel	128 (Low)	189 (Mid)	251 (High)	128 (Low)	189 (Mid)	251 (High)	4132 (Low)	4182 (Mid)	4233 (High)
Frequency (MHz)	824.2	836.4	848.8	824.2	836.4	848.8	826.4	836.4	846.6
Peak-to-Average Ratio (dB)	0.31	0.34	0.35	2.72	2.85	2.95	2.96	3.16	2.96

PCS Band									
Modes	GSM1900 (GPRS class 8)			GSM1900 (EDGE class 8)			WCDMA Band II (RMC 12.2Kbps)		
Channel	512 (Low)	661 (Mid)	810 (High)	512 (Low)	661 (Mid)	810 (High)	9262 (Low)	9400 (Mid)	9538 (High)
Frequency (MHz)	1850.2	1880	1909.8	1850.2	1880	1909.8	1852.4	1880	1907.6
Peak-to-Average Ratio (dB)	0.30	0.34	0.32	2.66	2.69	2.71	3.28	3.24	3.24



3.2.6 Test Result (Plots) of Peak-to-Average Ratio

Band :	GSM 850	Test Mode :	GSM Link (GMSK)
--------	---------	-------------	-----------------

Peak-to-Average Ratio on Channel 128 (824.2 MHz)

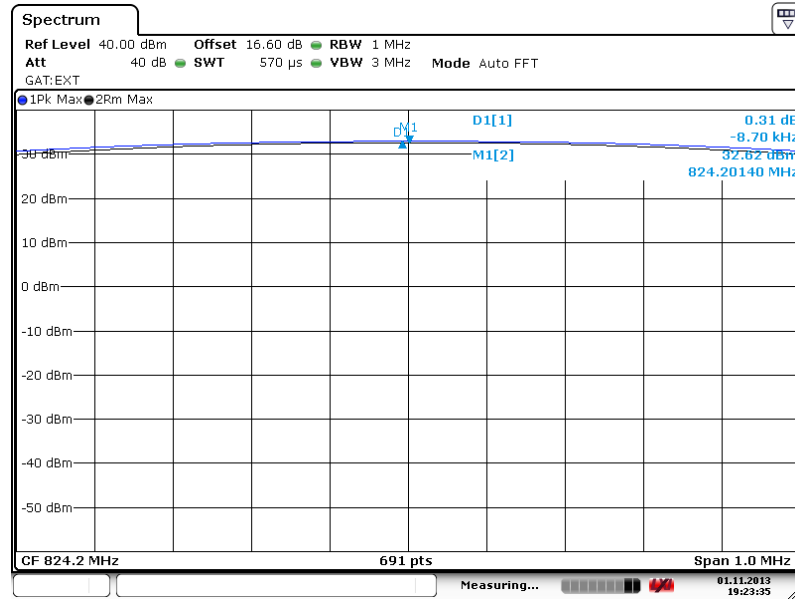

Date: 1.NOV.2013 19:23:36

Peak-to-Average Ratio on Channel 189 (836.4 MHz)

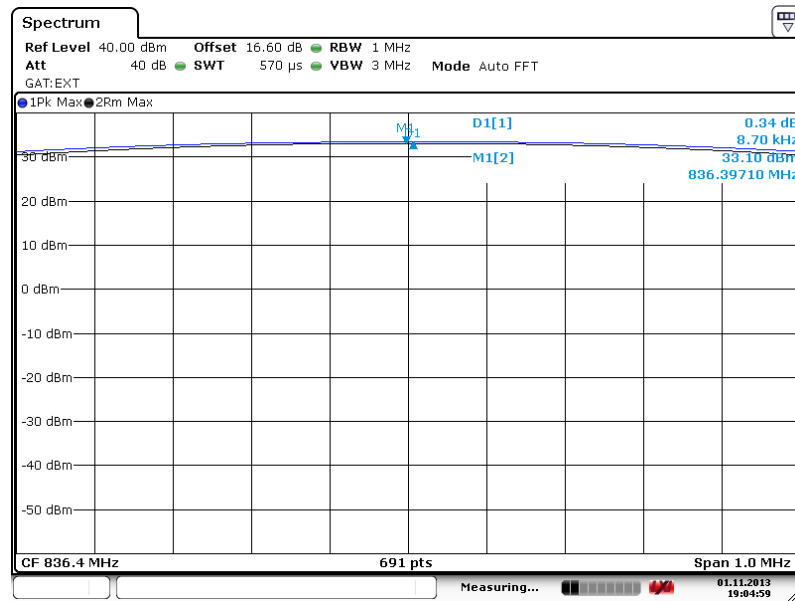

Date: 1.NOV.2013 19:04:59



Peak-to-Average Ratio on Channel 251 (848.8 MHz)

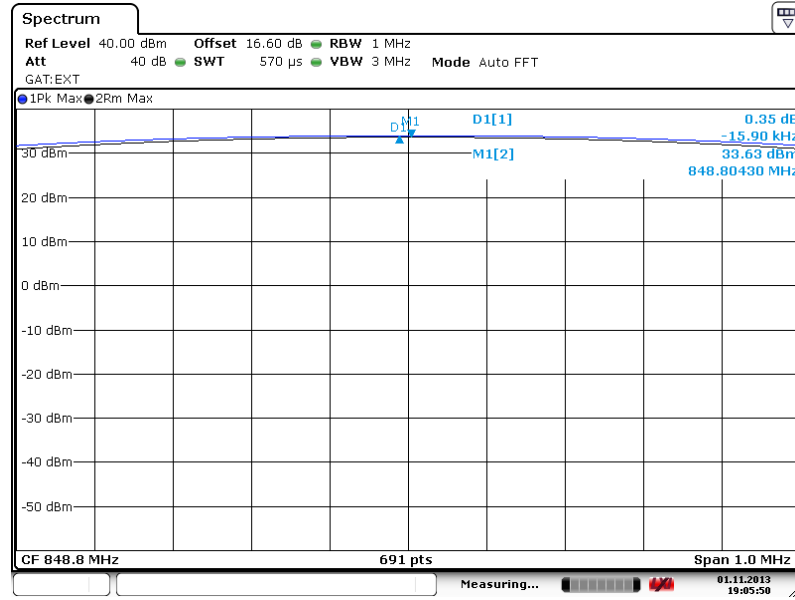

Date: 1.NOV.2013 19:05:50

Note: The total loss is 16.60 dB of the RF cable and attenuator, and has been compensated to the spectrum analyzer offset.



Band :	GSM 850	Test Mode :	EDGE class 8 Link (8PSK)
---------------	---------	--------------------	--------------------------

Peak-to-Average Ratio on Channel 128 (824.2 MHz)

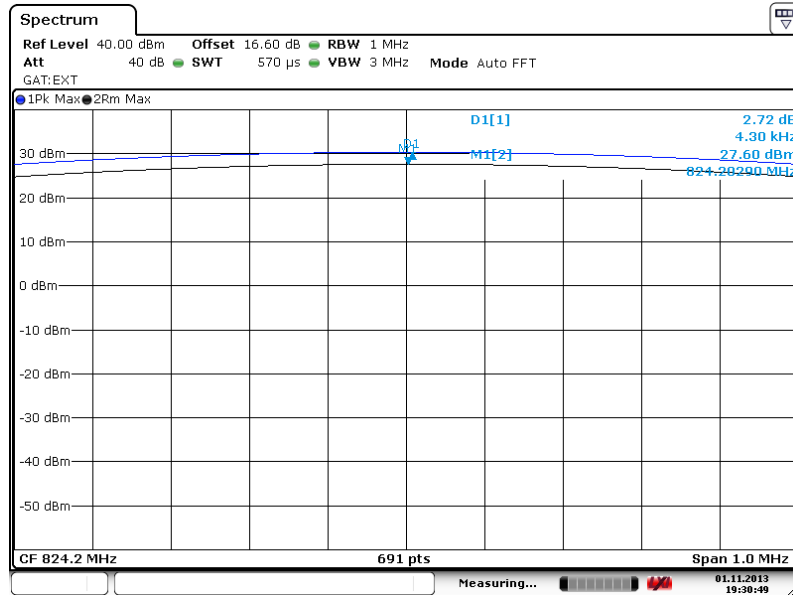

Date: 1.NOV.2013 19:30:49

Peak-to-Average Ratio on Channel 189 (836.4 MHz)

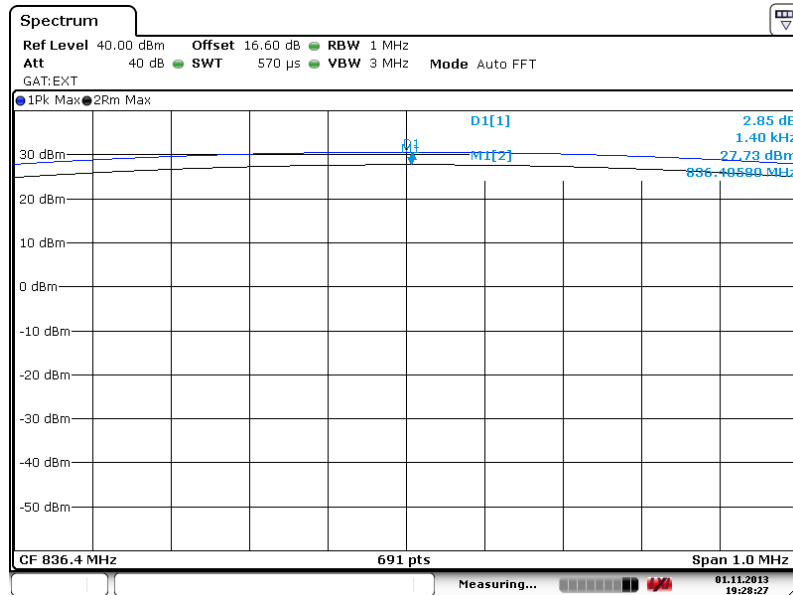

Date: 1.NOV.2013 19:28:27



Peak-to-Average Ratio on Channel 251 (848.8 MHz)

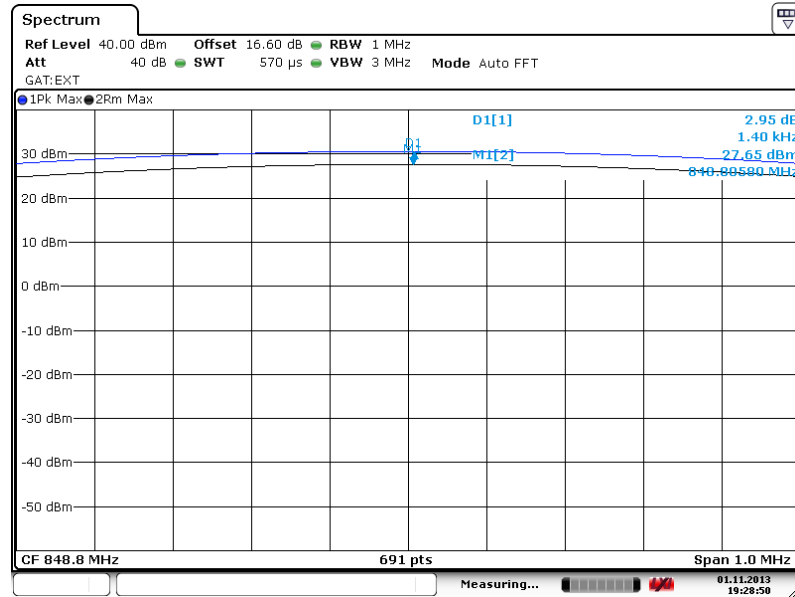

Date: 1.NOV.2013 19:28:50

Note: The total loss is 16.60 dB of the RF cable and attenuator, and has been compensated to the spectrum analyzer offset.



Band :	GSM 1900	Test Mode :	GPRS class 8 Link (GMSK)
--------	----------	-------------	--------------------------

Peak-to-Average Ratio on Channel 512 (1850.2 MHz)

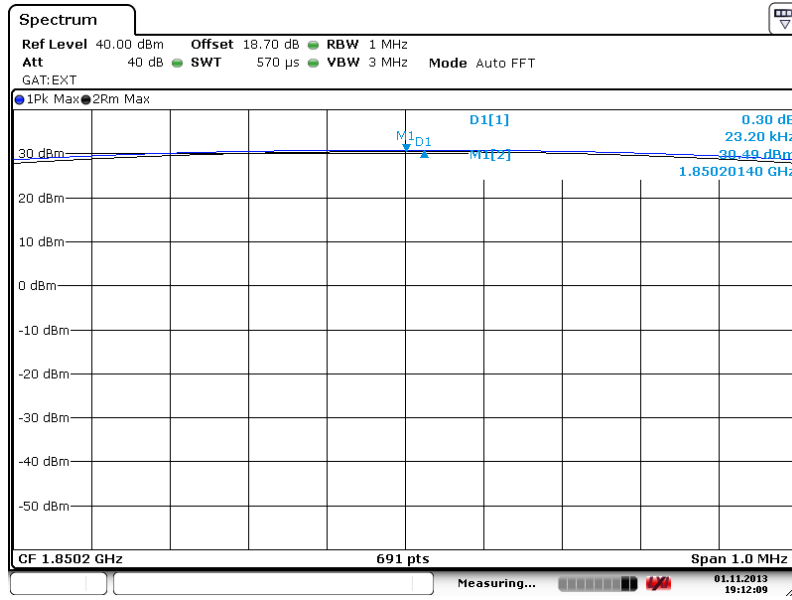

Peak-to-Average Ratio on Channel 661 (1880.0 MHz)

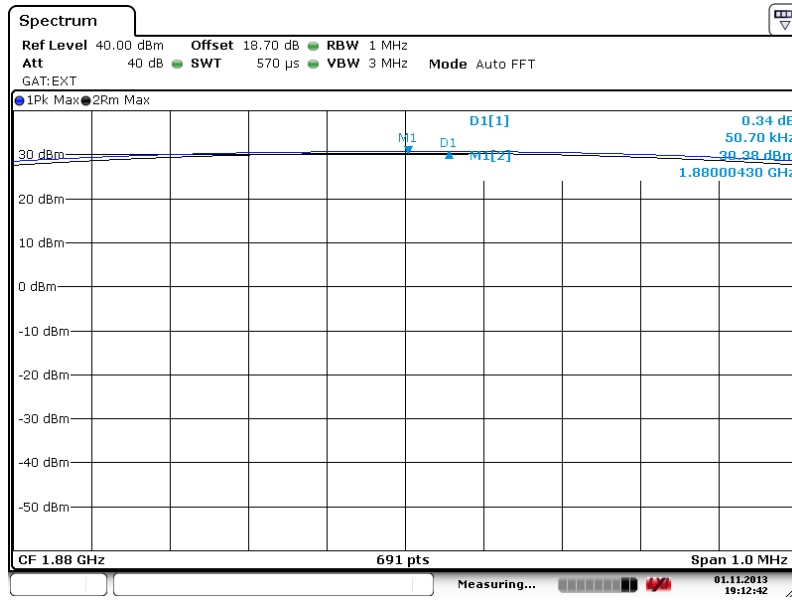



Peak-to-Average Ratio on Channel 810 (1909.8 MHz)

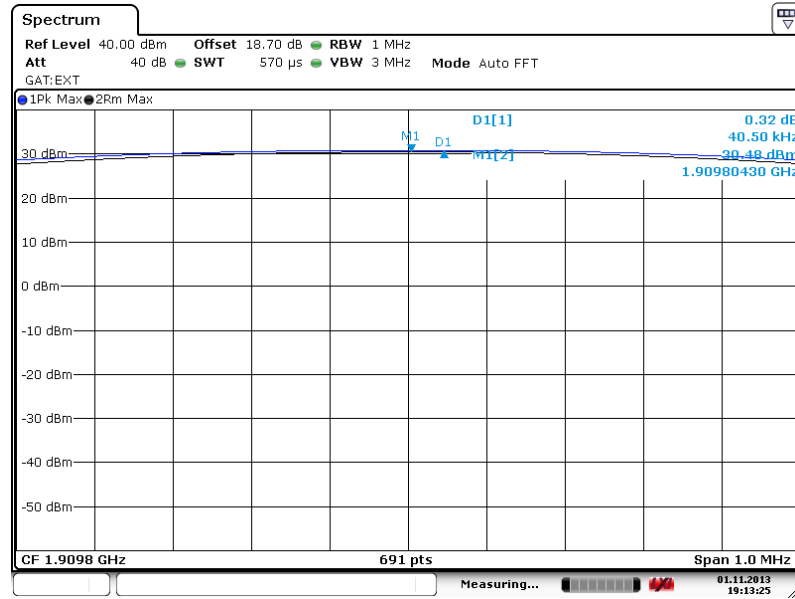

Date: 1.NOV.2013 19:13:25

Note: The total loss is 18.70 dB of the RF cable and attenuator, and has been compensated to the spectrum analyzer offset.



Band :	GSM 1900	Test Mode :	EDGE class 8 Link (8PSK)
---------------	----------	--------------------	--------------------------

Peak-to-Average Ratio on Channel 512 (1850.2 MHz)

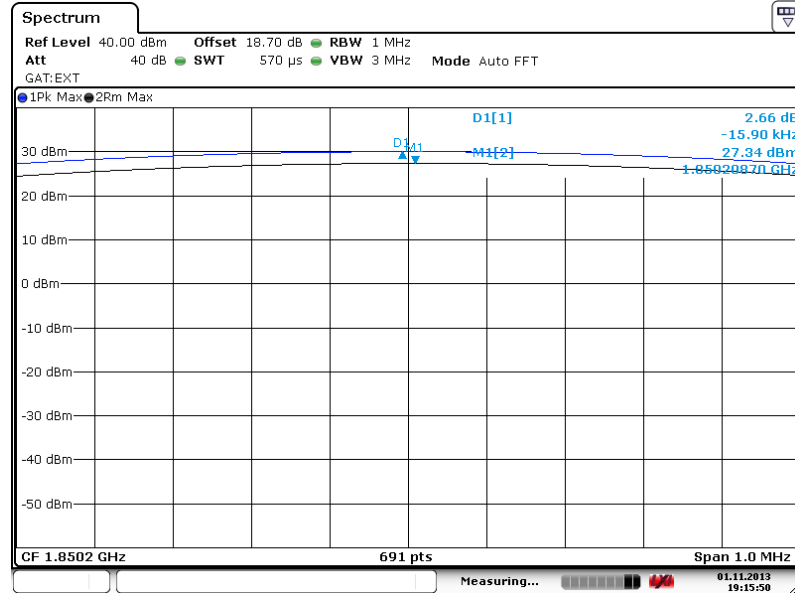

Date: 1.NOV.2013 19:15:50

Peak-to-Average Ratio on Channel 661 (1880.0 MHz)

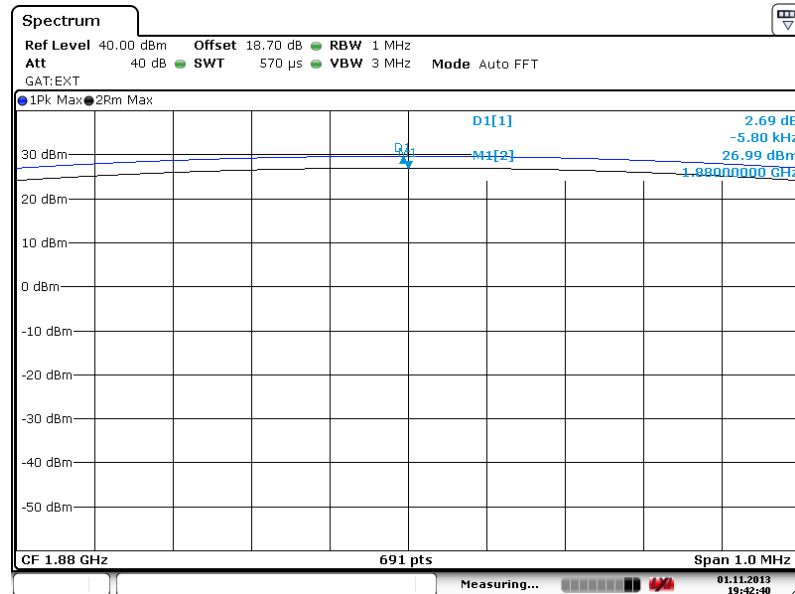

Date: 1.NOV.2013 19:42:40



Peak-to-Average Ratio on Channel 810 (1909.8 MHz)

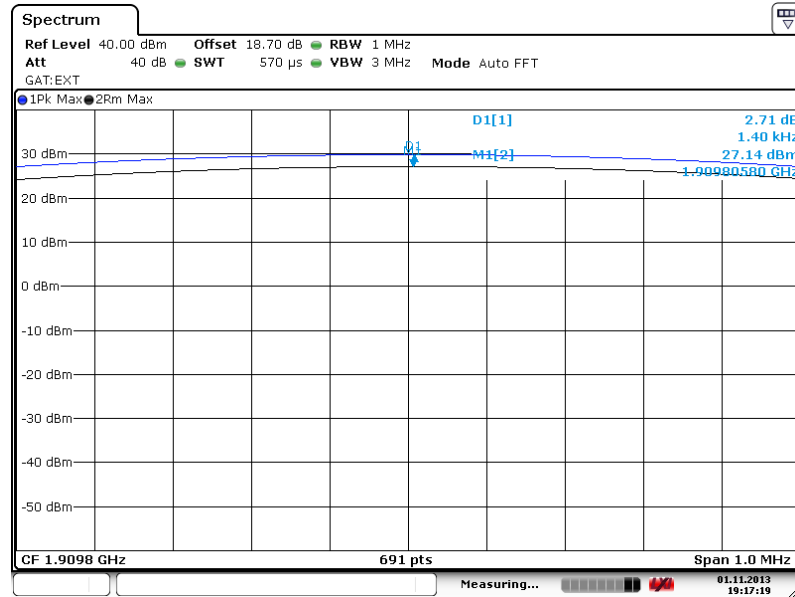

Date: 1.NOV.2013 19:17:20

Note: The total loss is 18.70 dB of the RF cable and attenuator, and has been compensated to the spectrum analyzer offset.



Band :	WCDMA Band V	Test Mode :	RMC 12.2Kbps Link (QPSK)
---------------	--------------	--------------------	--------------------------

Peak-to-Average Ratio on Channel 4132 (826.4 MHz)

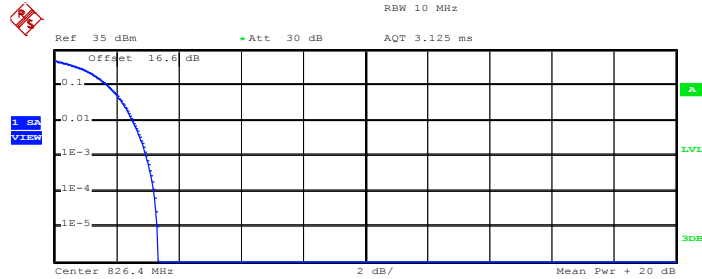

Complementary Cumulative Distribution Function (100000 samples)

Trace 1

Mean	18.65 dBm
Peak	21.98 dBm
Crest	3.34 dB
10 %	1.72 dB
1 %	2.52 dB
.1 %	2.96 dB
.01 %	3.20 dB

Date: 1.NOV.2013 22:18:17

Peak-to-Average Ratio on Channel 4182 (836.4 MHz)

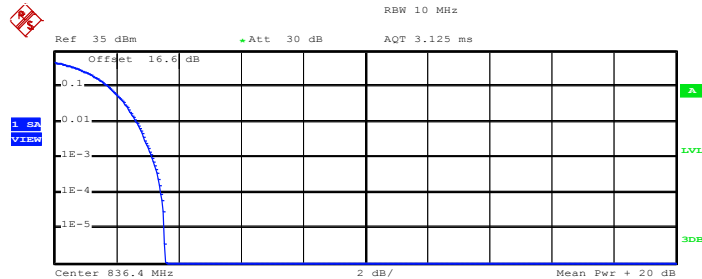

Complementary Cumulative Distribution Function (100000 samples)

Trace 1

Mean	19.91 dBm
Peak	23.47 dBm
Crest	3.56 dB
10 %	1.76 dB
1 %	2.64 dB
.1 %	3.16 dB
.01 %	3.44 dB

Date: 1.NOV.2013 22:18:34



Peak-to-Average Ratio on Channel 4233 (846.6 MHz)

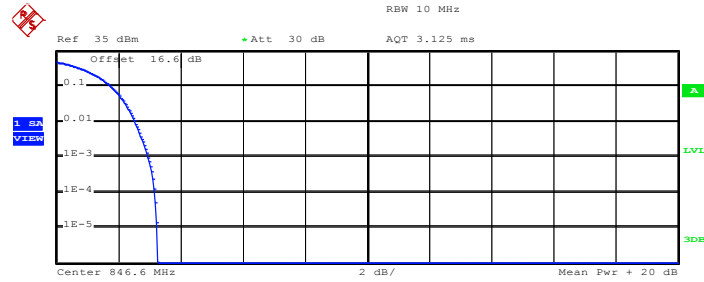

Complementary Cumulative Distribution Function (100000 samples)

Trace 1

Mean	19.65 dBm
Peak	22.90 dBm
Crest	3.25 dB
10 %	1.76 dB
1 %	2.56 dB
.1 %	2.96 dB
.01 %	3.16 dB

Date: 1.NOV.2013 22:18:52

Note: The total loss is 16.60 dB of the RF cable and attenuator, and has been compensated to the spectrum analyzer offset.



Band :	WCDMA Band II	Test Mode :	RMC 12.2Kbps Link (QPSK)
---------------	---------------	--------------------	--------------------------

Peak-to-Average Ratio on Channel 9262 (1852.4 MHz)

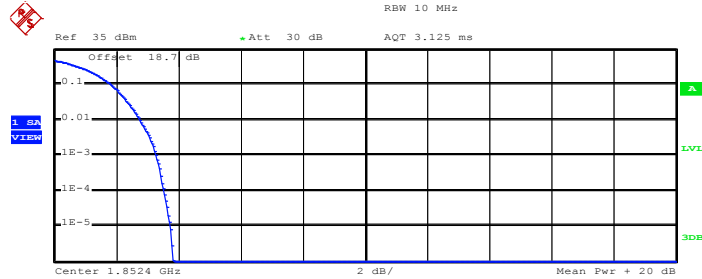

Complementary Cumulative Distribution Function (100000 samples)

Trace 1
Mean 20.64 dBm
Peak 24.45 dBm
Crest 3.81 dB

10 %	1.84 dB
1 %	2.76 dB
.1 %	3.28 dB
.01 %	3.56 dB

Date: 1.NOV.2013 22:10:34

Peak-to-Average Ratio on Channel 9400 (1880.0 MHz)

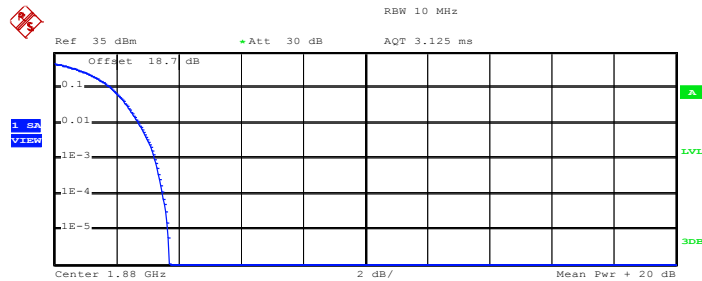

Complementary Cumulative Distribution Function (100000 samples)

Trace 1
Mean 20.81 dBm
Peak 24.52 dBm
Crest 3.72 dB

10 %	1.84 dB
1 %	2.72 dB
.1 %	3.24 dB
.01 %	3.52 dB

Date: 1.NOV.2013 22:10:50



Peak-to-Average Ratio on Channel 9538 (1907.6 MHz)

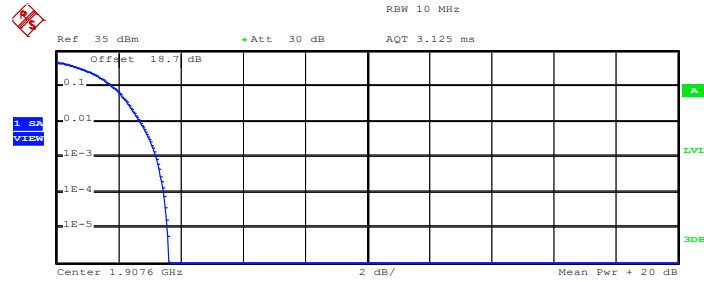

Complementary Cumulative Distribution Function (100000 samples)

Trace 1	
Mean	19.90 dBm
Peak	23.54 dBm
Crest	3.64 dB
10 %	1.84 dB
1 %	2.72 dB
.1 %	3.24 dB
.01 %	3.48 dB

Date: 1.NOV.2013 22:11:08

Note: The total loss is 18.70 dB of the RF cable and attenuator, and has been compensated to the spectrum analyzer offset.



3.3 Effective Radiated Power and Effective Isotropic Radiated Power Measurement

3.3.1 Description of the ERP/EIRP Measurement

The substitution method, in ANSI / TIA / EIA-603-C-2004, was used for ERP/EIRP measurement, and the spectrum analyzer configuration follows KDB 971168 D01 Power Meas. License Digital Systems v02r01. The ERP of mobile transmitters must not exceed 7 Watts and the EIRP of mobile transmitters are limited to 2 Watts.

3.3.2 Measuring Instruments

The measuring equipment is listed in the section 4 of this test report.

3.3.3 Test Procedures

1. The EUT was placed on a non-conductive rotating platform with 0.8 meter height in a semi-anechoic chamber. The radiated emission at the fundamental frequency was measured at 3 m with a test antenna and a spectrum analyzer with RBW= 1MHz, VBW= 3MHz for GSM, RBW= 100 kHz, VBW= 300 kHz, used channel power option with bandwidth=5MHz for WCDMA, and RMS detector settings per KDB 971168 D01.
2. During the measurement, the EUT was enforced in maximum power and linked with a base station. The highest emission was recorded from analyzer power level (LVL) from the 360 degrees rotation of the turntable and the test antenna raised and lowered over a range from 1 to 4 meters in both horizontally and vertically polarized orientations.
3. Effective Isotropic Radiated Power (EIRP) was measured by substitution method according to TIA/EIA-603-C. The EUT was replaced by dipole antenna (substitution antenna) at same location, and then a known power from S.G. was applied into the dipole antenna through a Tx cable, and then recorded the maximum Analyzer reading through raised and lowered the test antenna. The correction factor (in dB) = S.G. - Tx Cable loss + Substitution antenna gain - Analyzer reading. Then the EUT's EIRP was calculated with the correction factor, $EIRP = LVL + \text{Correction factor}$ and $ERP = EIRP - 2.15$.

3.3.4 Test Setup

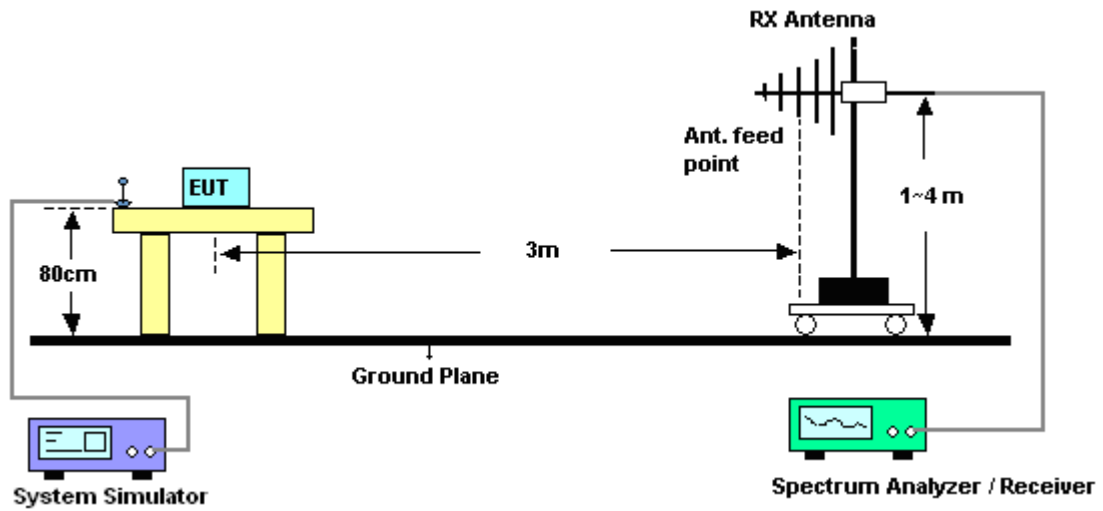



3.3.5 Test Result of ERP

GSM850 (GSM) Radiated Power ERP				
Horizontal Polarization				
Frequency (MHz)	LVL (dBm)	Correction Factor (dB)	ERP (dBm)	ERP (W)
824.2	-3.21	31.54	26.18	0.41
836.4	-2.72	32.04	27.17	0.52
848.8	-2.41	32.59	28.03	0.64
Vertical Polarization				
Frequency (MHz)	LVL (dBm)	Correction Factor (dB)	ERP (dBm)	ERP (W)
824.2	-11.77	32.93	19.01	0.08
836.4	-10.81	32.82	19.86	0.10
848.8	-10.65	33.62	20.82	0.12

* ERP = LVL (dBm) + Correction Factor (dB) – 2.15

GSM850 (EDGE class 8) Radiated Power ERP				
Horizontal Polarization				
Frequency (MHz)	LVL (dBm)	Correction Factor (dB)	ERP (dBm)	ERP (W)
824.2	-5.66	31.54	23.73	0.24
836.4	-5.77	32.04	24.12	0.26
848.8	-5.80	32.59	24.64	0.29
Vertical Polarization				
Frequency (MHz)	LVL (dBm)	Correction Factor (dB)	ERP (dBm)	ERP (W)
824.2	-18.90	32.93	11.88	0.02
836.4	-17.85	32.82	12.82	0.02
848.8	-18.67	33.62	12.80	0.02

* ERP = LVL (dBm) + Correction Factor (dB) – 2.15



WCDMA Band V (RMC 12.2Kbps) Radiated Power ERP				
Horizontal Polarization				
Frequency (MHz)	LVL (dBm)	Correction Factor (dB)	ERP (dBm)	ERP (W)
826.40	-11.60	31.44	17.69	0.06
836.40	-12.03	32.04	17.86	0.06
846.60	-11.56	32.63	18.92	0.08
Vertical Polarization				
Frequency (MHz)	LVL (dBm)	Correction Factor (dB)	ERP (dBm)	ERP (W)
826.40	-20.96	32.78	9.67	0.01
836.40	-20.45	32.82	10.22	0.01
846.60	-21.04	33.4	10.21	0.01

* ERP = LVL (dBm) + Correction Factor (dB) – 2.15

3.3.6 Test Result of EIRP

GSM1900 (GPRS class 8) Radiated Power EIRP				
Horizontal Polarization				
Frequency (MHz)	LVL (dBm)	Correction Factor (dB)	EIRP (dBm)	EIRP (W)
1850.2	-13.42	43.69	30.27	1.06
1880.0	-13.25	44.79	31.54	1.43
1909.8	-13.92	43.59	29.67	0.93
Vertical Polarization				
Frequency (MHz)	LVL (dBm)	Correction Factor (dB)	EIRP (dBm)	EIRP (W)
1850.2	-27.66	45.72	18.06	0.06
1880.0	-25.42	46.78	21.36	0.14
1909.8	-24.89	46.77	21.88	0.15

* EIRP = LVL (dBm) + Correction Factor (dB)

GSM1900 (EDGE class 8) Radiated Power EIRP				
Horizontal Polarization				
Frequency (MHz)	LVL (dBm)	Correction Factor (dB)	EIRP (dBm)	EIRP (W)
1850.2	-18.14	43.69	25.55	0.36
1880.0	-18.24	44.79	26.55	0.45
1909.8	-19.32	43.59	24.27	0.27
Vertical Polarization				
Frequency (MHz)	LVL (dBm)	Correction Factor (dB)	EIRP (dBm)	EIRP (W)
1850.2	-25.32	45.72	20.40	0.11
1880.0	-25.16	46.78	21.62	0.15
1909.8	-24.14	46.77	22.63	0.18

* EIRP = LVL (dBm) + Correction Factor (dB)



WCDMA Band II (RMC 12.2Kbps) Radiated Power EIRP				
Horizontal Polarization				
Frequency (MHz)	LVL (dBm)	Correction Factor (dB)	EIRP (dBm)	EIRP (W)
1852.40	-22.41	43.69	21.28	0.13
1880.00	-22.19	44.79	22.60	0.18
1907.60	-22.00	43.59	21.59	0.14
Vertical Polarization				
Frequency (MHz)	LVL (dBm)	Correction Factor (dB)	EIRP (dBm)	EIRP (W)
1852.40	-28.86	45.72	16.86	0.05
1880.00	-30.19	46.78	16.59	0.05
1907.60	-28.94	46.77	17.83	0.06

* EIRP = LVL (dBm) + Correction Factor (dB)

3.4 99% Occupied Bandwidth and 26dB Bandwidth Measurement

3.4.1 Description of 99% Occupied Bandwidth and 26dB Bandwidth Measurement

The 99% occupied bandwidth is the width of a frequency band such that, below the lower and above the upper frequency limits, the mean powers emitted are each equal to a specified percentage 0.5% of the total mean transmitted power.

The emission bandwidth is defined as the width of the signal between two points, located at the 2 sides of the carrier frequency, outside of which all emissions are attenuated at least 26 dB below the transmitter power.

3.4.2 Measuring Instruments

The measuring equipment is listed in the section 4 of this test report.

3.4.3 Test Procedures

1. The EUT was connected to Spectrum Analyzer and Base Station via power divider.
2. The RF output of EUT was connected to the spectrum analyzer by RF cable and attenuator. The path loss was compensated to the results for each measurement.
3. The 99% occupied bandwidth were measured, set RBW= 1% of span, VBW= 3*RBW, sample detector, trace maximum hold.
4. The 26dB bandwidth were measured, set RBW= 1% of EBW, VBW= 3*RBW, peak detector, trace maximum hold.

3.4.4 Test Setup

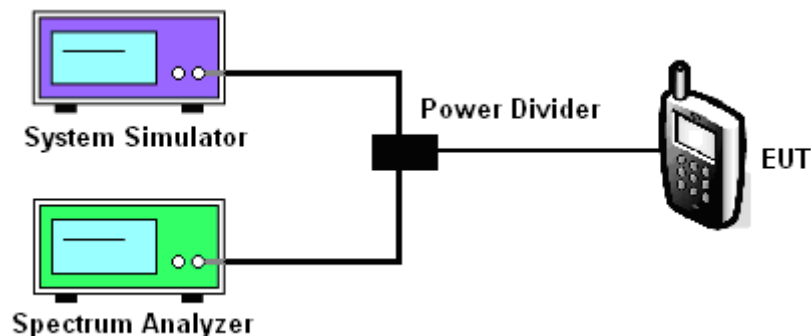



3.4.5 Test Result of Occupied Bandwidth and 26dB Bandwidth

Cellular Band						
Modes	GSM850 (GSM)			GSM850 (EDGE class 8)		
Channel	128 (Low)	189 (Mid)	251 (High)	128 (Low)	189 (Mid)	251 (High)
Frequency (MHz)	824.2	836.4	848.8	824.2	836.4	848.8
99% OBW (kHz)	248.00	242.00	244.00	244.00	246.00	244.00
26dB BW (kHz)	310.00	316.00	310.00	304.00	304.00	308.00

PCS Band						
Modes	GSM1900 (GPRS class 8)			GSM1900 (EDGE class 8)		
Channel	512 (Low)	661 (Mid)	810 (High)	512 (Low)	661 (Mid)	810 (High)
Frequency (MHz)	1850.2	1880	1909.8	1850.2	1880	1909.8
99% OBW (kHz)	246.00	244.00	248.00	246.00	244.00	246.00
26dB BW (kHz)	312.00	312.00	314.00	306.00	306.00	312.00

Cellular Band			
Modes	WCDMA Band V (RMC 12.2Kbps)		
Channel	4132 (Low)	4182 (Mid)	4233 (High)
Frequency (MHz)	826.4	836.4	846.6
99% OBW (MHz)	4.20	4.16	4.18
26dB BW (MHz)	4.74	4.74	4.78

PCS Band			
Modes	WCDMA Band II (RMC 12.2Kbps)		
Channel	9262 (Low)	9400 (Mid)	9538 (High)
Frequency (MHz)	1852.4	1880	1907.6
99% OBW (MHz)	4.16	4.18	4.18
26dB BW (MHz)	4.74	4.74	4.76



3.4.6 Test Result (Plots) of Occupied Bandwidth and 26dB Bandwidth

Band :	GSM 850	Test Mode :	GSM Link (GMSK)
--------	---------	-------------	-----------------

99% Occupied Bandwidth Plot on Channel 128 (824.2 MHz)

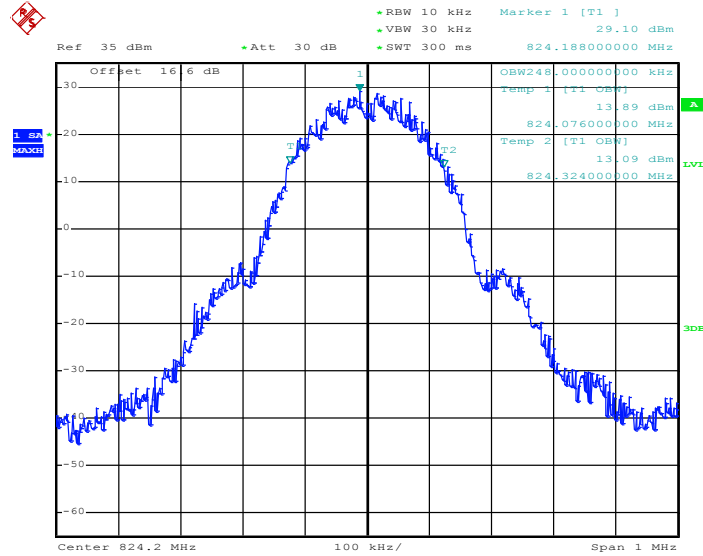

Date: 1.NOV.2013 21:59:41

26dB Bandwidth Plot on Channel 128 (824.2 MHz)

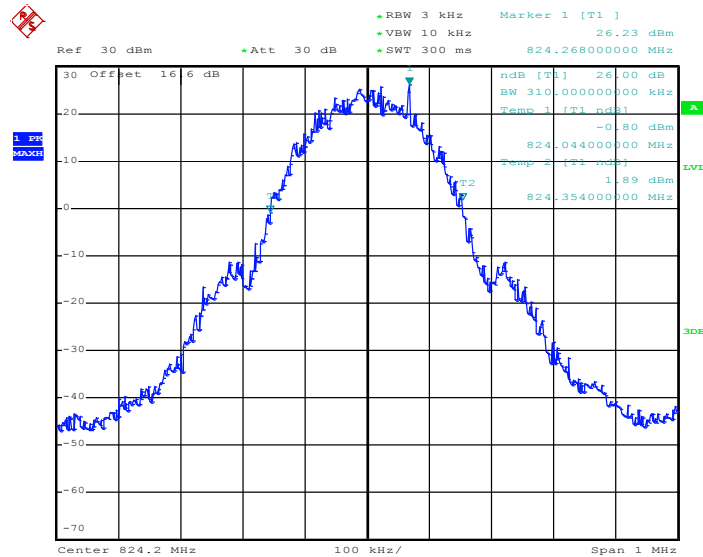

Date: 1.NOV.2013 21:52:02



99% Occupied Bandwidth Plot on Channel 189 (836.4 MHz)

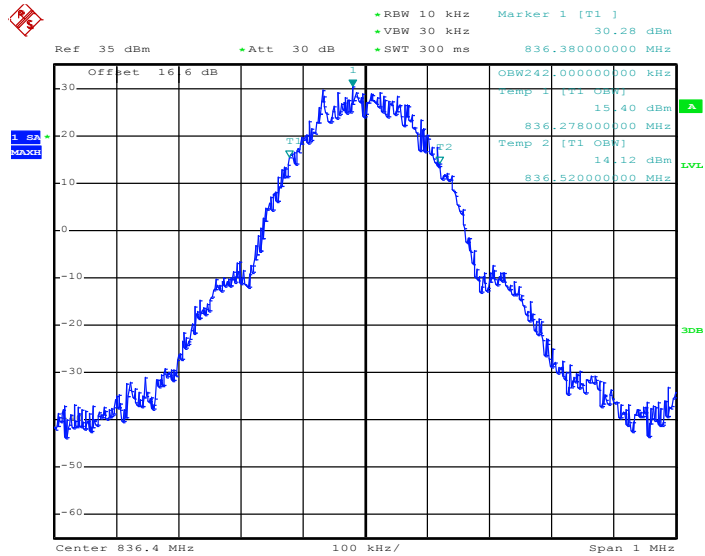

Date: 1.NOV.2013 21:58:56

26dB Bandwidth Plot on Channel 189 (836.4 MHz)

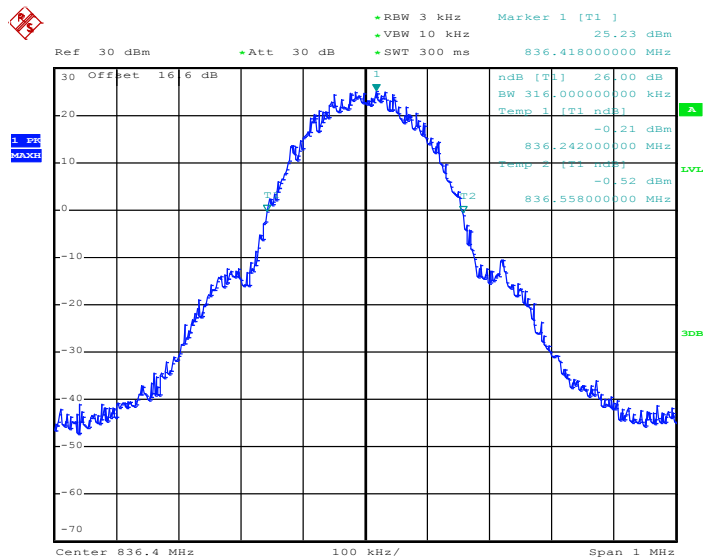

Date: 1.NOV.2013 21:52:28



99% Occupied Bandwidth Plot on Channel 251 (848.8 MHz)

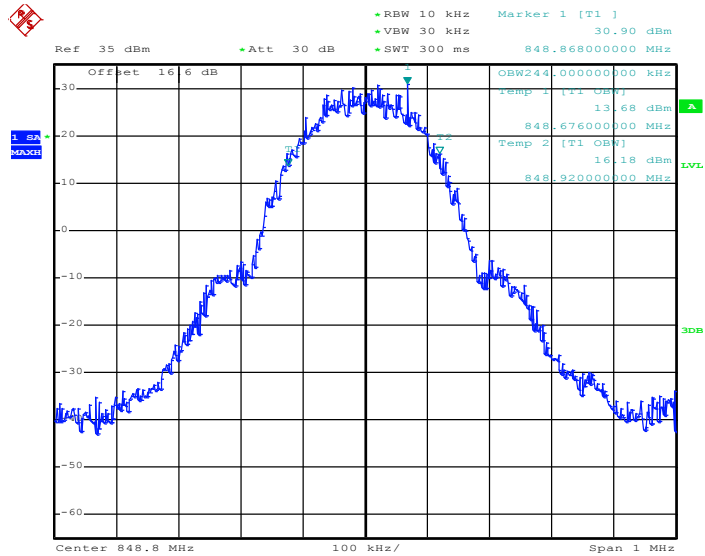

Date: 1.NOV.2013 21:58:09

26dB Bandwidth Plot on Channel 251 (848.8 MHz)

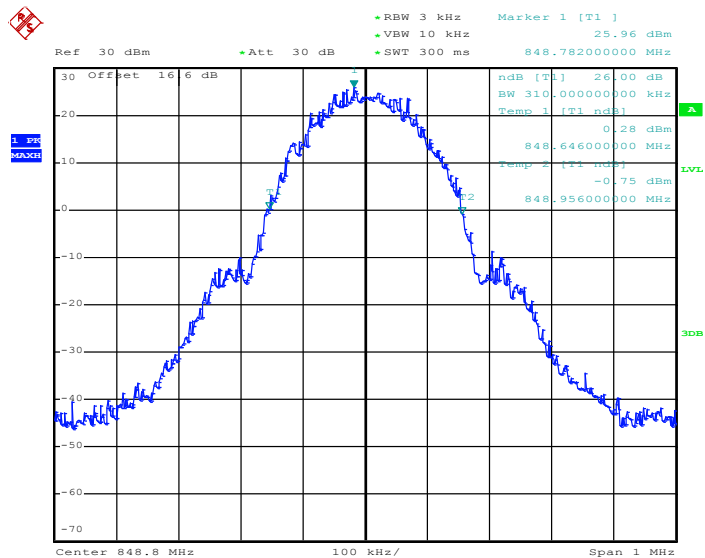

Date: 1.NOV.2013 21:52:54

Note: The total loss is 16.60 dB of the RF cable and attenuator, and has been compensated to the spectrum analyzer offset.



Band :	GSM 850	Test Mode :	EDGE class 8 Link (8PSK)
---------------	---------	--------------------	--------------------------

99% Occupied Bandwidth Plot on Channel 128 (824.2 MHz)

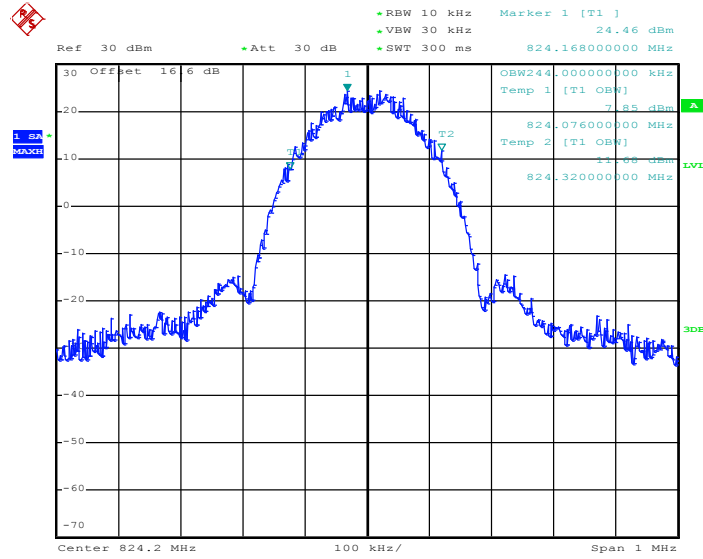

Date: 1.NOV.2013 21:46:28

26dB Bandwidth Plot on Channel 128 (824.2 MHz)

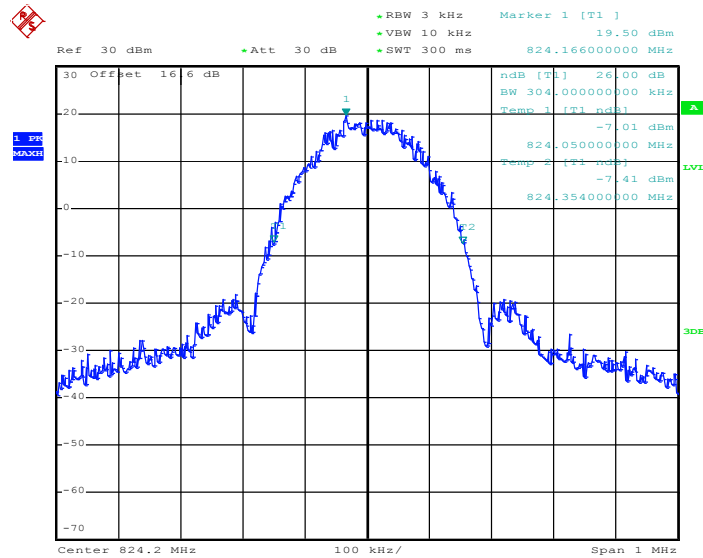

Date: 1.NOV.2013 21:40:04



99% Occupied Bandwidth Plot on Channel 189 (836.4 MHz)

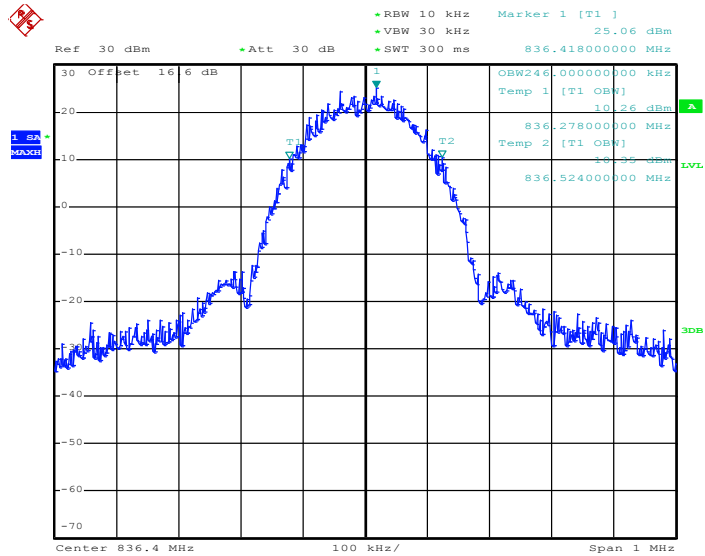

Date: 1.NOV.2013 21:47:46

26dB Bandwidth Plot on Channel 189 (836.4 MHz)

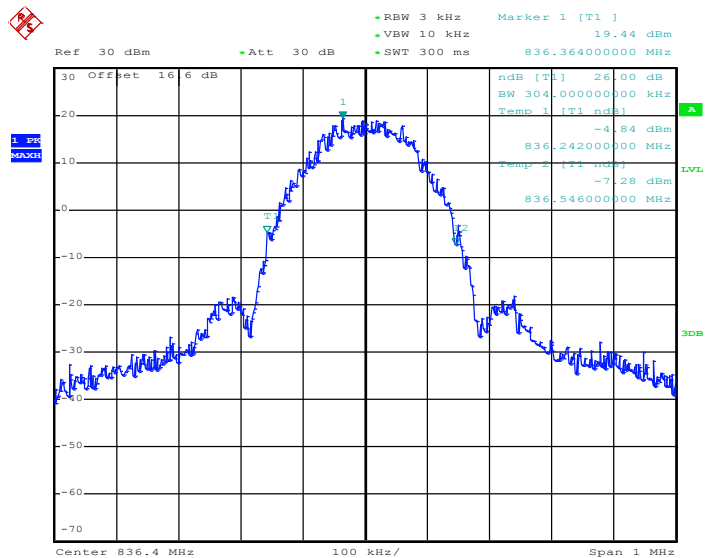

Date: 1.NOV.2013 21:40:30



99% Occupied Bandwidth Plot on Channel 251 (848.8 MHz)

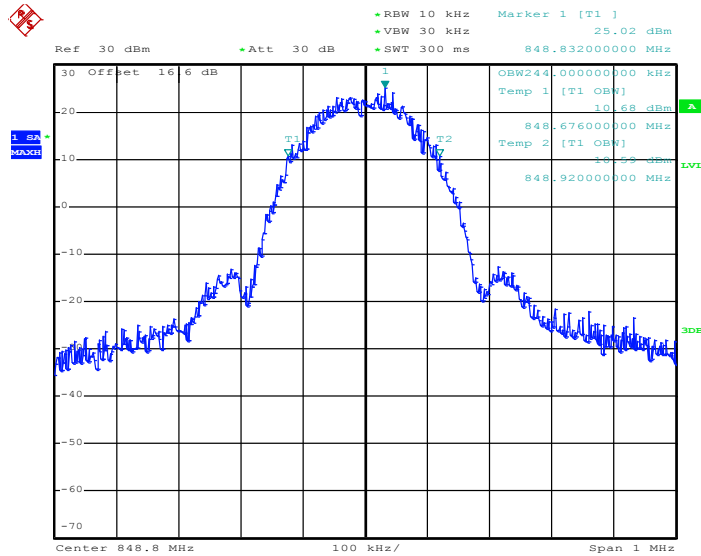

Date: 1.NOV.2013 21:49:21

26dB Bandwidth Plot on Channel 251 (848.8 MHz)

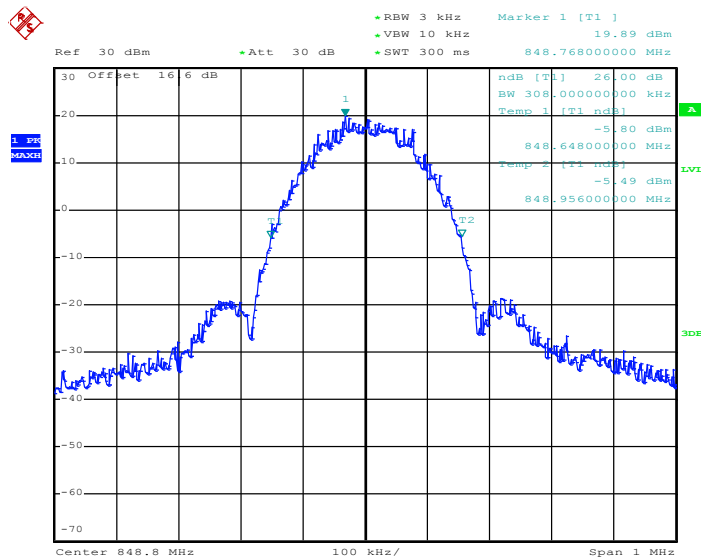

Date: 1.NOV.2013 21:40:56

Note: The total loss is 16.60 dB of the RF cable and attenuator, and has been compensated to the spectrum analyzer offset.



Band :	GSM 1900	Test Mode :	GPRS class 8 Link (GMSK)
---------------	----------	--------------------	--------------------------

99% Occupied Bandwidth Plot on Channel 512 (1850.2 MHz)

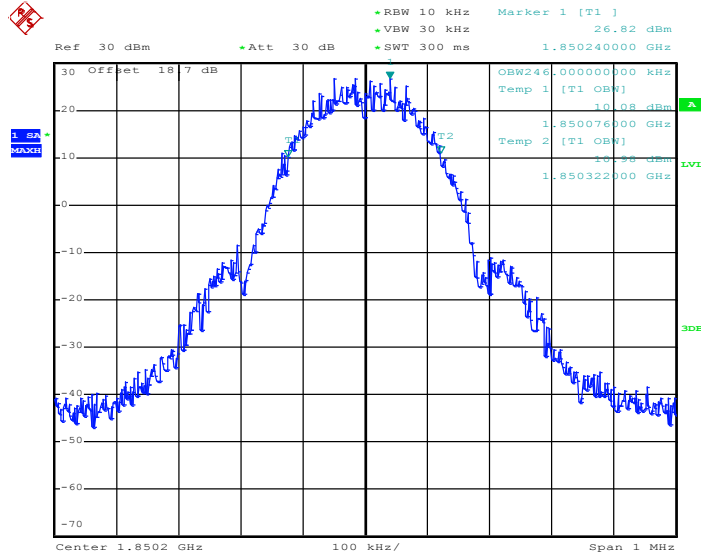

Date: 1.NOV.2013 21:16:18

26dB Bandwidth Plot on Channel 512 (1850.2 MHz)

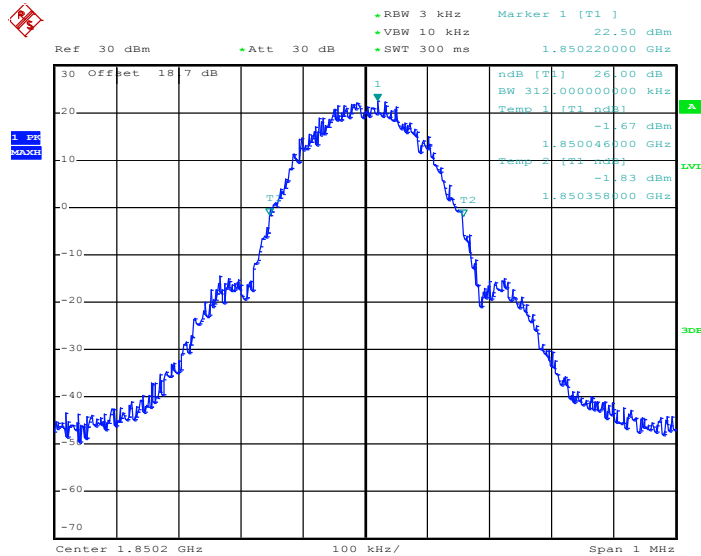

Date: 1.NOV.2013 21:14:59



99% Occupied Bandwidth Plot on Channel 661 (1880.0 MHz)

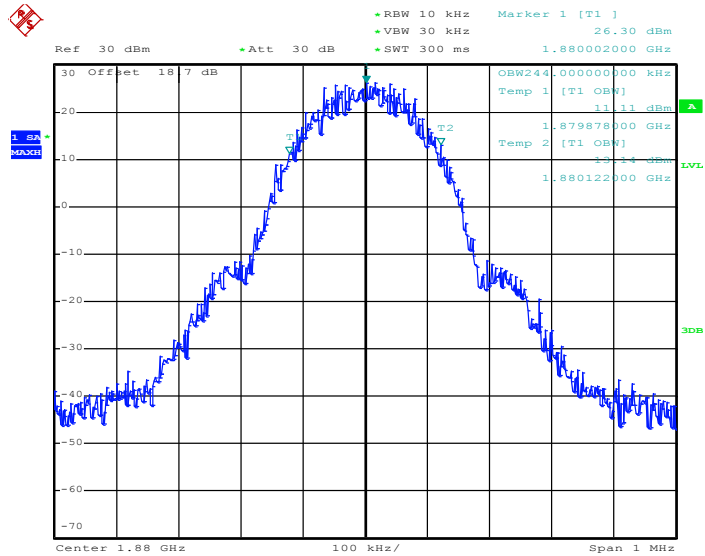

Date: 1.NOV.2013 21:16:44

26dB Bandwidth Plot on Channel 661 (1880.0 MHz)

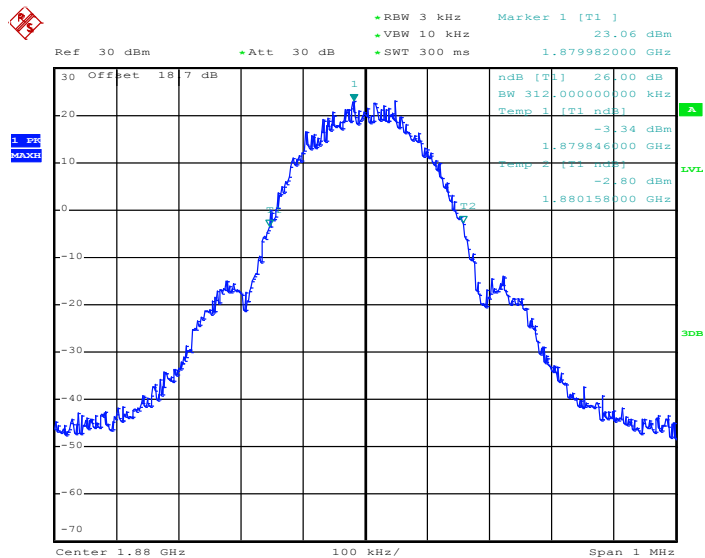

Date: 1.NOV.2013 21:15:25



99% Occupied Bandwidth Plot on Channel 810 (1909.8 MHz)

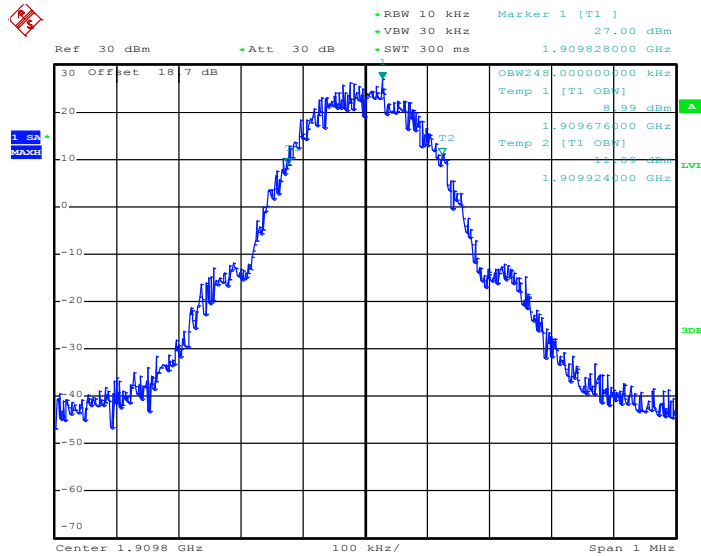

Date: 1.NOV.2013 21:17:10

26dB Bandwidth Plot on Channel 810 (1909.8 MHz)

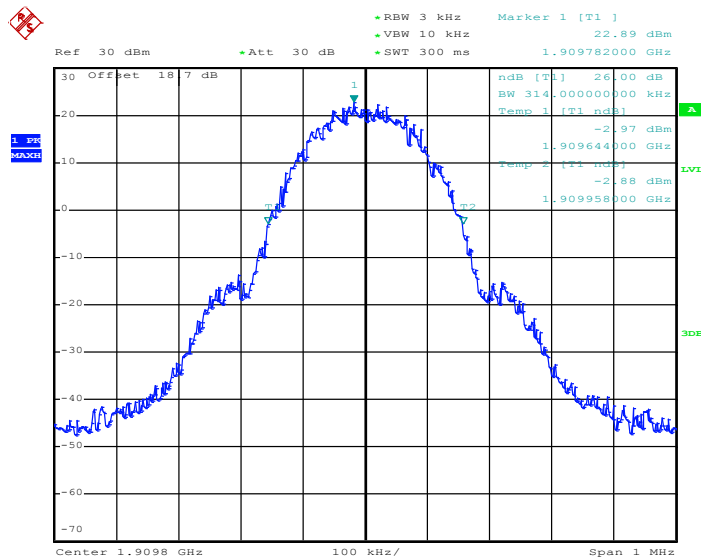

Date: 1.NOV.2013 21:15:51

Note: The total loss is 18.70 dB of the RF cable and attenuator, and has been compensated to the spectrum analyzer offset.



Band :	GSM 1900	Test Mode :	EDGE class 8 Link (8PSK)
---------------	----------	--------------------	--------------------------

99% Occupied Bandwidth Plot on Channel 512 (1850.2 MHz)

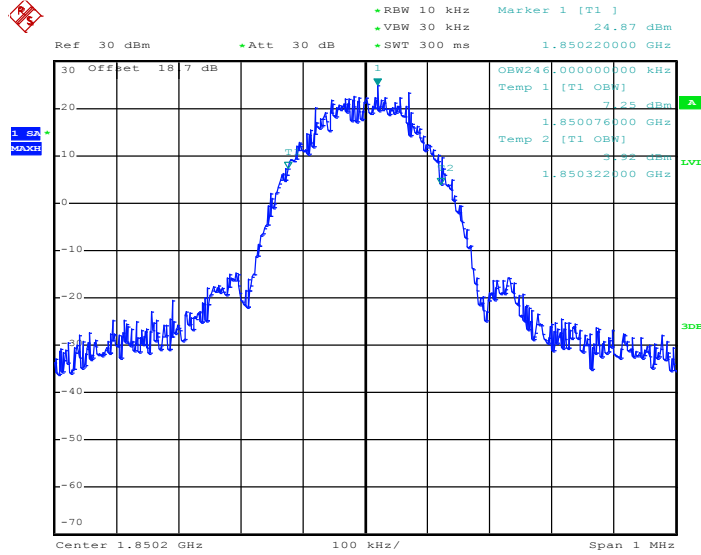

Date: 1.NOV.2013 21:09:31

26dB Bandwidth Plot on Channel 512 (1850.2 MHz)

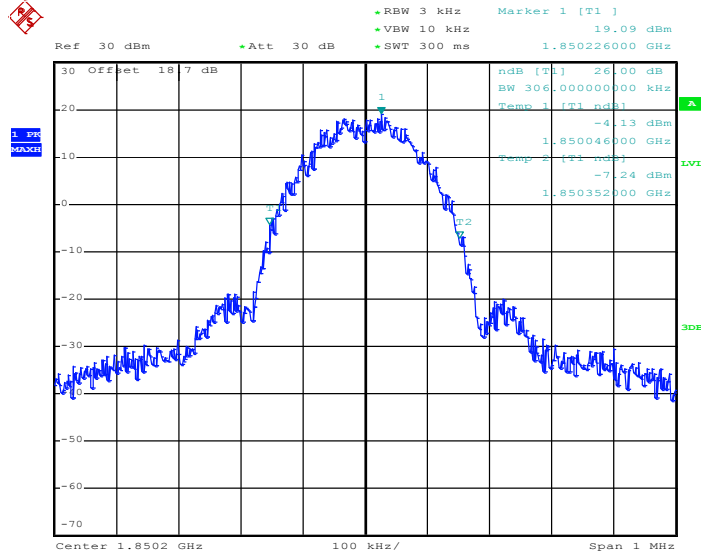

Date: 1.NOV.2013 21:03:07



99% Occupied Bandwidth Plot on Channel 661 (1880.0 MHz)

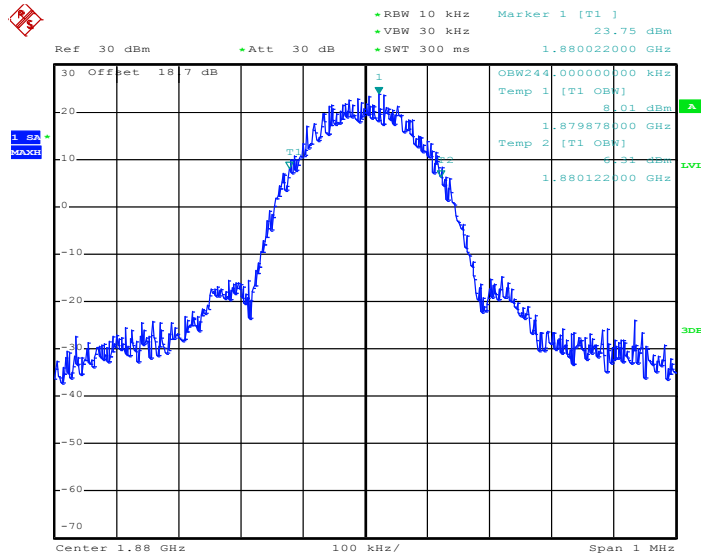

Date: 1.NOV.2013 21:10:23

26dB Bandwidth Plot on Channel 661 (1880.0 MHz)

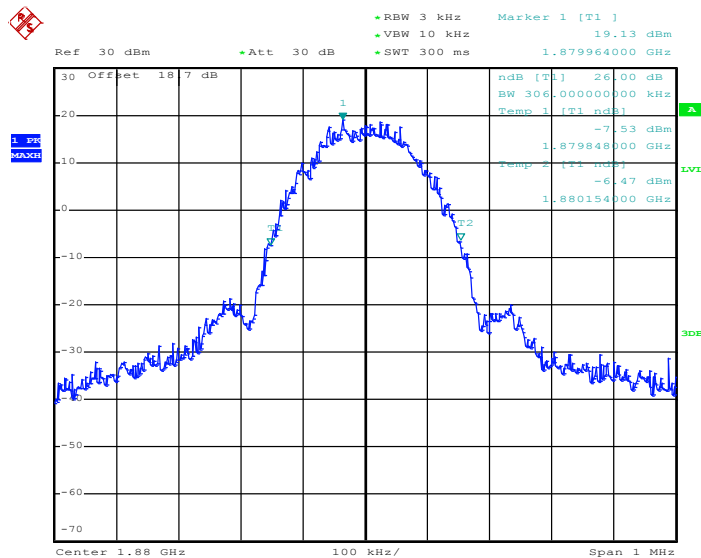

Date: 1.NOV.2013 21:03:33



99% Occupied Bandwidth Plot on Channel 810 (1909.8 MHz)

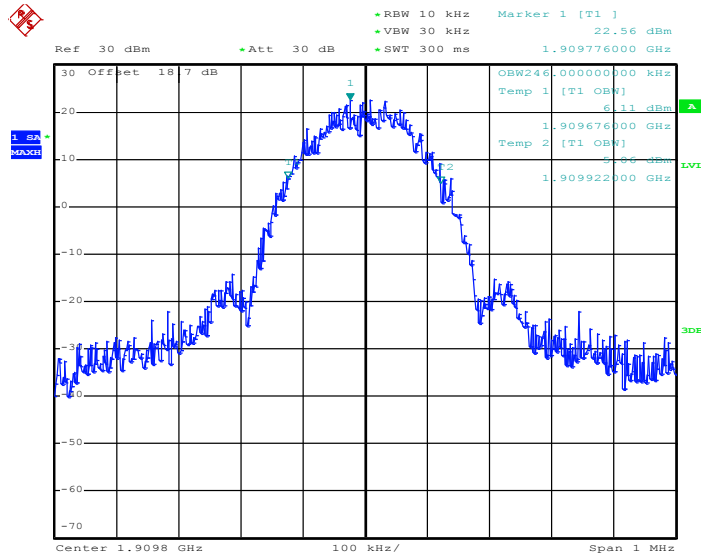

Date: 1.NOV.2013 21:05:17

26dB Bandwidth Plot on Channel 810 (1909.8 MHz)

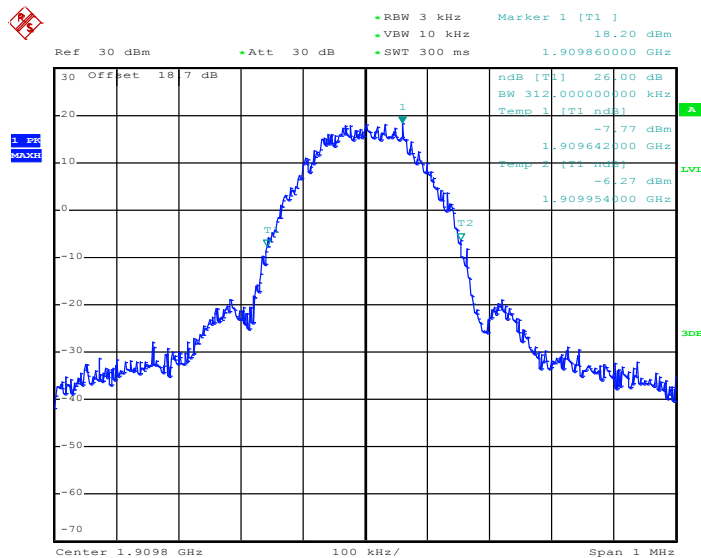

Date: 1.NOV.2013 21:03:59

Note: The total loss is 18.70 dB of the RF cable and attenuator, and has been compensated to the spectrum analyzer offset.



Band :	WCDMA Band V	Test Mode :	RMC 12.2Kbps Link (QPSK)
---------------	--------------	--------------------	--------------------------

99% Occupied Bandwidth Plot on Channel 4132 (826.4 MHz)

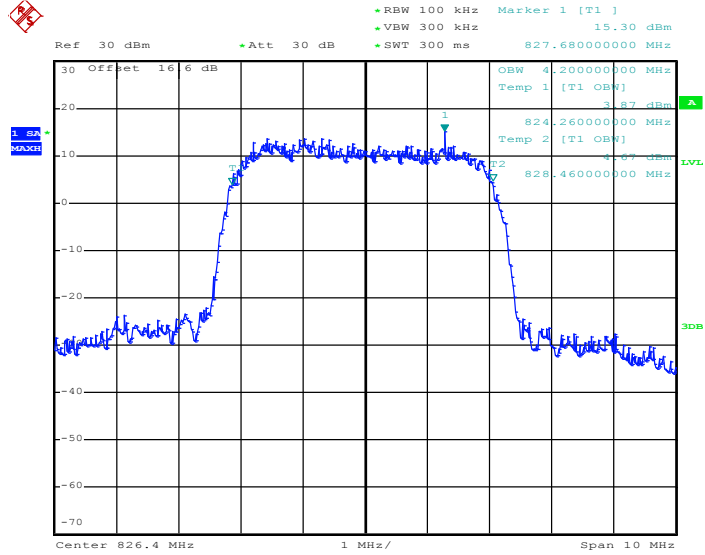

Date: 1.NOV.2013 22:22:24

26dB Bandwidth Plot on Channel 4132 (826.4 MHz)

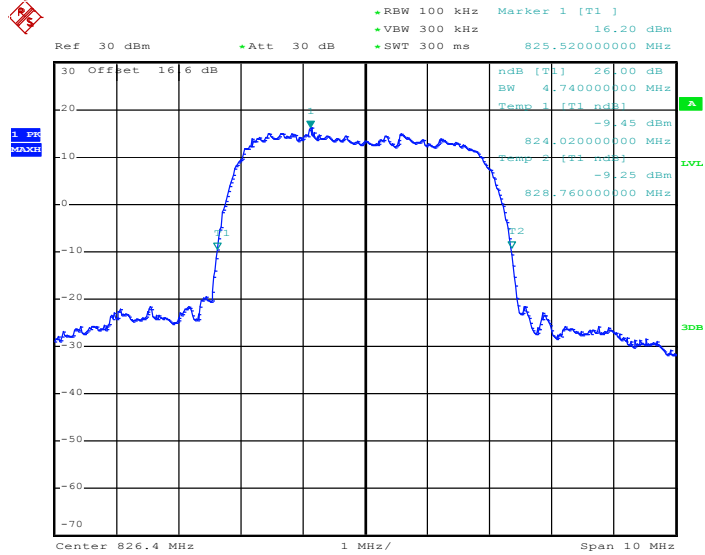

Date: 1.NOV.2013 22:21:05



99% Occupied Bandwidth Plot on Channel 4182 (836.4 MHz)

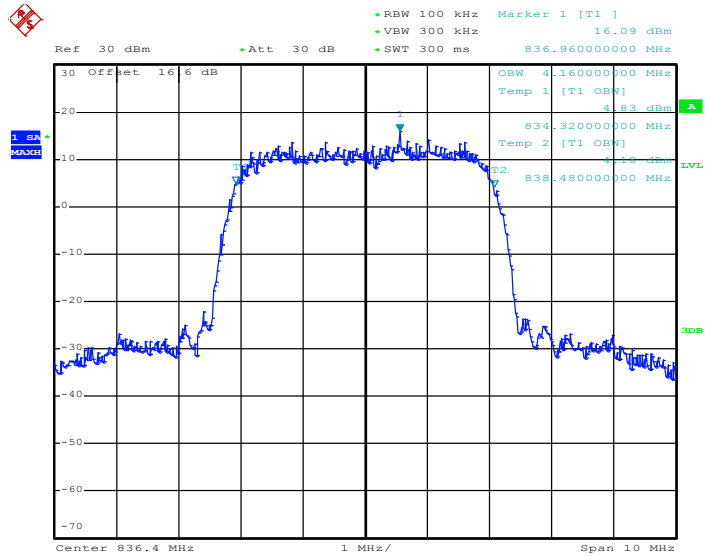

Date: 1.NOV.2013 22:22:49

26dB Bandwidth Plot on Channel 4182 (836.4 MHz)

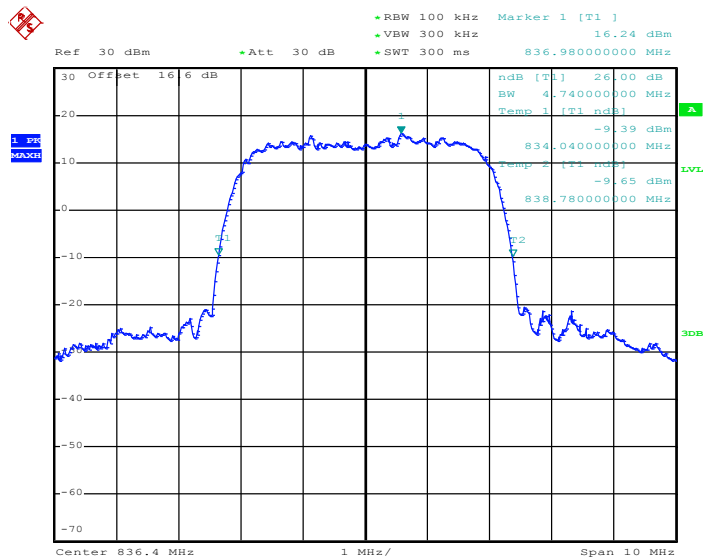

Date: 1.NOV.2013 22:21:31



99% Occupied Bandwidth Plot on Channel 4233 (846.6 MHz)

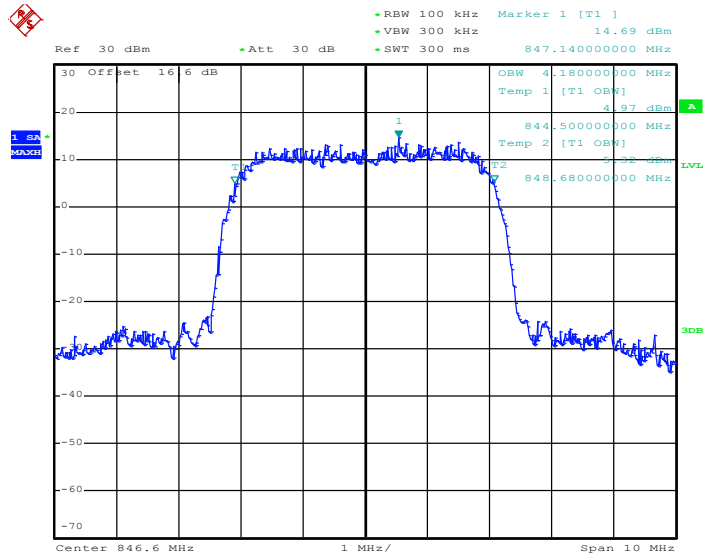

Date: 1.NOV.2013 22:23:15

26dB Bandwidth Plot on Channel 4233 (846.6 MHz)

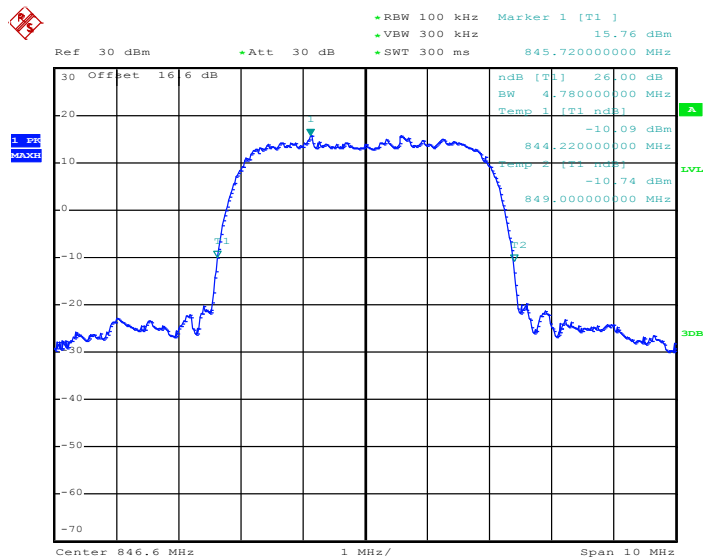

Date: 1.NOV.2013 22:21:57

Note: The total loss is 16.60 dB of the RF cable and attenuator, and has been compensated to the spectrum analyzer offset.



Band :	WCDMA Band II	Test Mode :	RMC 12.2Kbps Link (QPSK)
---------------	---------------	--------------------	--------------------------

99% Occupied Bandwidth Plot on Channel 9262 (1852.4 MHz)

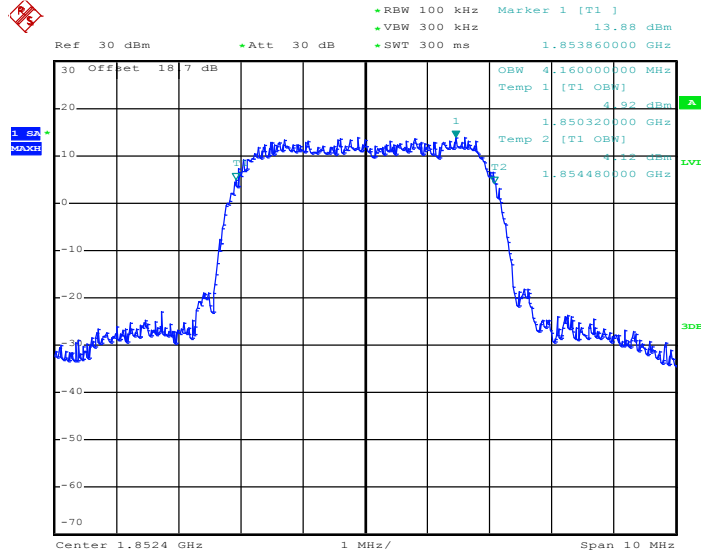

Date: 1.NOV.2013 22:14:36

26dB Bandwidth Plot on Channel 9262 (1852.4 MHz)

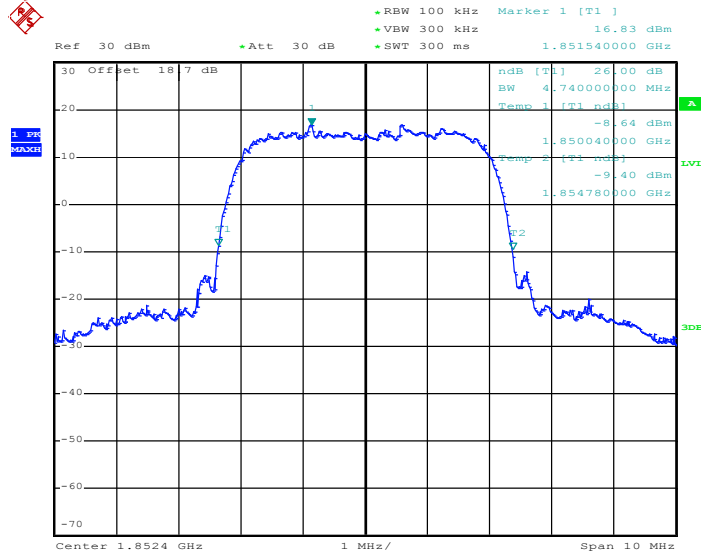

Date: 1.NOV.2013 22:13:17



99% Occupied Bandwidth Plot on Channel 9400 (1880.0 MHz)

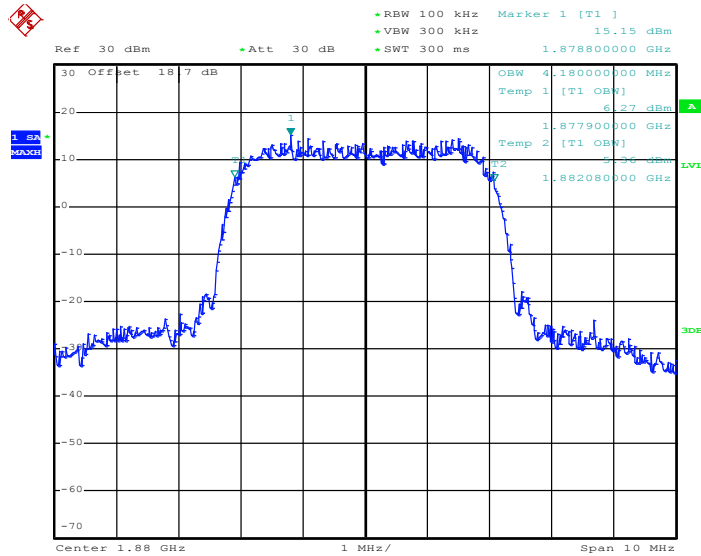

Date: 1.NOV.2013 22:15:02

26dB Bandwidth Plot on Channel 9400 (1880.0 MHz)

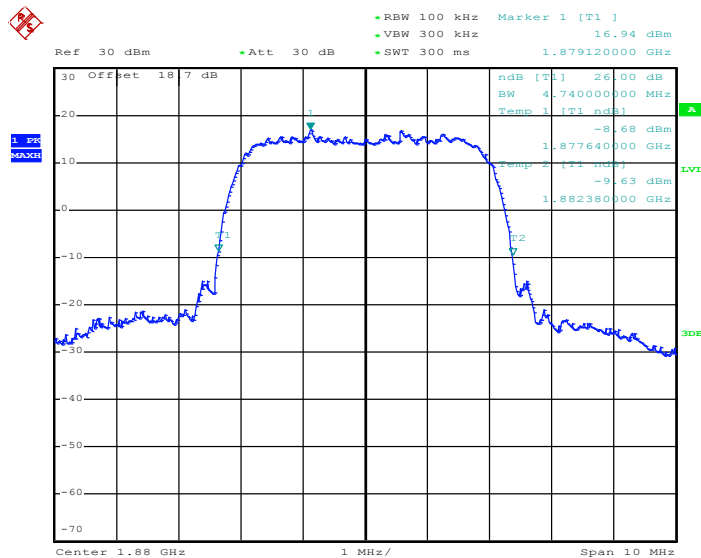

Date: 1.NOV.2013 22:13:44



99% Occupied Bandwidth Plot on Channel 9538 (1907.6 MHz)

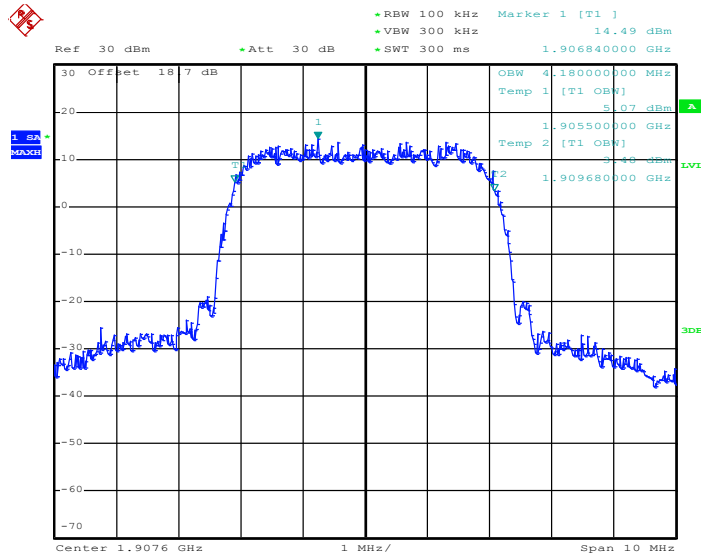

Date: 1.NOV.2013 22:15:28

26dB Bandwidth Plot on Channel 9538 (1907.6 MHz)

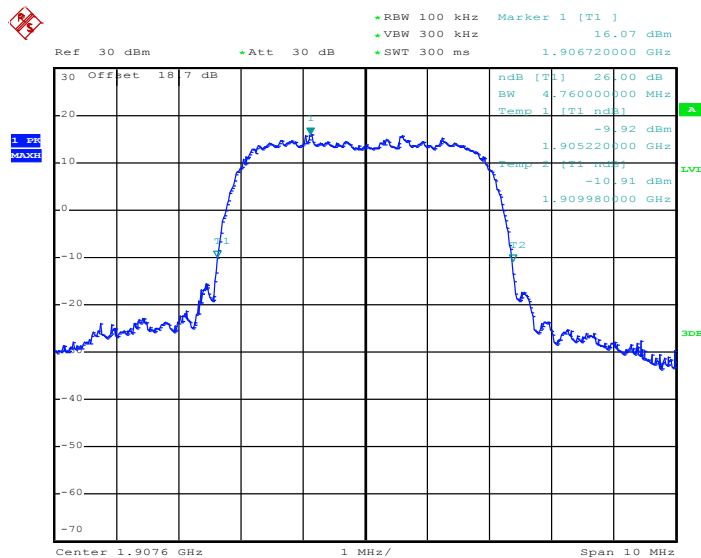

Date: 1.NOV.2013 22:14:10

Note: The total loss is 18.70 dB of the RF cable and attenuator, and has been compensated to the spectrum analyzer offset.

3.5 Band Edge Measurement

3.5.1 Description of Band Edge Measurement

The power of any emission outside of the authorized operating frequency ranges must be lower than the transmitter power (P) by a factor of at least $43 + 10 \log (P)$ dB.

3.5.2 Measuring Instruments

The measuring equipment is listed in the section 4 of this test report.

3.5.3 Test Procedures

1. The EUT was connected to Spectrum Analyzer and Base Station via power divider.
2. The RF output of EUT was connected to the spectrum analyzer by RF cable and attenuator. The path loss was compensated to the results for each measurement.
3. The band edges of low and high channels for the highest RF powers were measured. Setting RBW as roughly BW/100.
4. The RF fundamental frequency should be excluded against the limit line in the operating frequency band.
5. The limit line is derived from $43 + 10\log(P)$ dB below the transmitter power P(Watts)

$$= P(W) - [43 + 10\log(P)] \text{ (dB)}$$

$$= [30 + 10\log(P)] \text{ (dBm)} - [43 + 10\log(P)] \text{ (dB)}$$

$$= -13\text{dBm}.$$

3.5.4 Test Setup

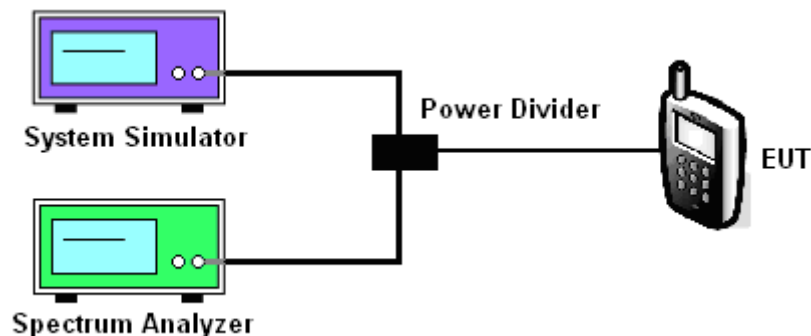



3.5.5 Test Result (Plots) of Conducted Band Edge

Band :	GSM850	Test Mode :	GSM Link (GMSK)
Correction Factor :	0.23dB	Maximum 26dB Bandwidth :	0.316MHz
Band Edge :	-17.28dBm	Measurement Value :	-17.51dBm

Lower Band Edge Plot on Channel 128 (824.2 MHz)

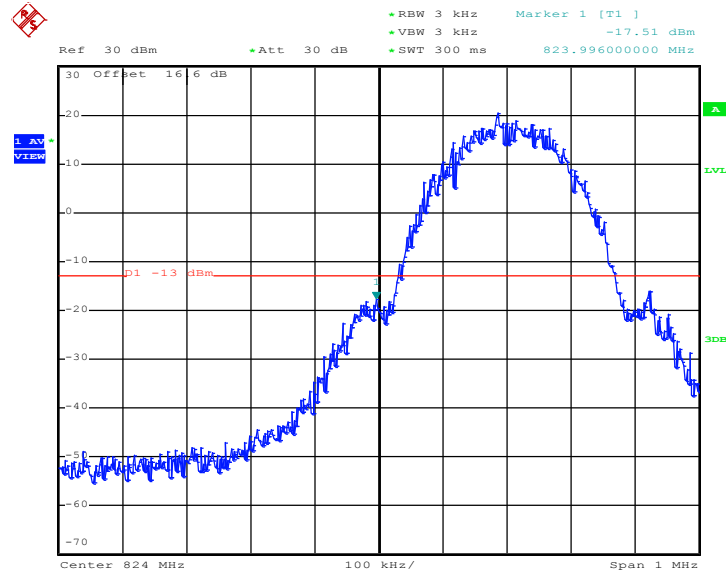

Date: 1.NOV.2013 21:54:39

1. Correction Factor(dB)= $10\log(1\% \text{ Emission BW/RBW})$
2. Band Edge= Measurement Value + Correction Factor(dB)
For example, $-17.51\text{dBm} + 0.23\text{dB} = -17.28\text{dBm}$
3. The total loss is 16.60 dB of the RF cable and attenuator, and has been compensated to the spectrum analyzer offset.



Band :	GSM850	Test Mode :	GSM Link (GMSK)
Correction Factor :	0.23dB	Maximum 26dB Bandwidth :	0.316MHz
Band Edge :	-14.80dBm	Measurement Value :	-15.03dBm

Higher Band Edge Plot on Channel 251 (848.8 MHz)

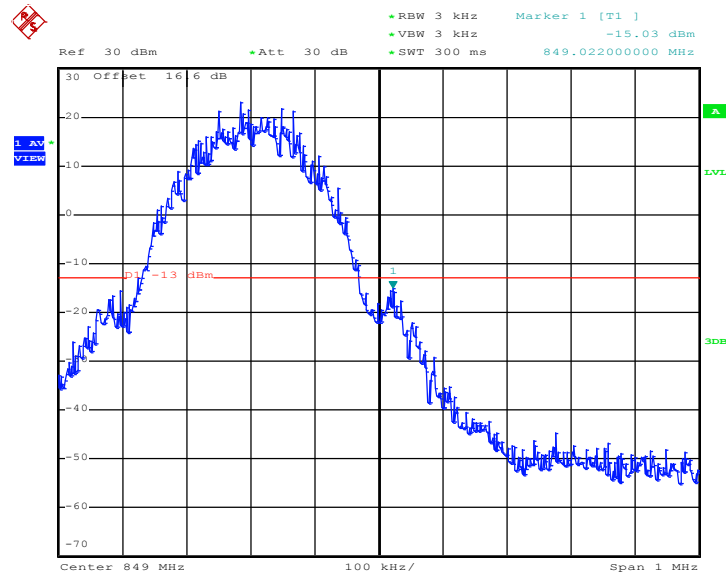

Date: 1.NOV.2013 21:55:06

1. Correction Factor(dB)= 10log(1% Emission BW/RBW)
2. Band Edge= Measurement Value + Correction Factor(dB)
3. The total loss is 16.60 dB of the RF cable and attenuator, and has been compensated to the spectrum analyzer offset.



Band :	GSM850	Test Mode :	EDGE class 8 Link (8PSK)
Correction Factor :	0.11dB	Maximum 26dB Bandwidth :	0.308MHz
Band Edge :	-23.74dBm	Measurement Value :	-23.85dBm

Lower Band Edge Plot on Channel 128 (824.2 MHz)

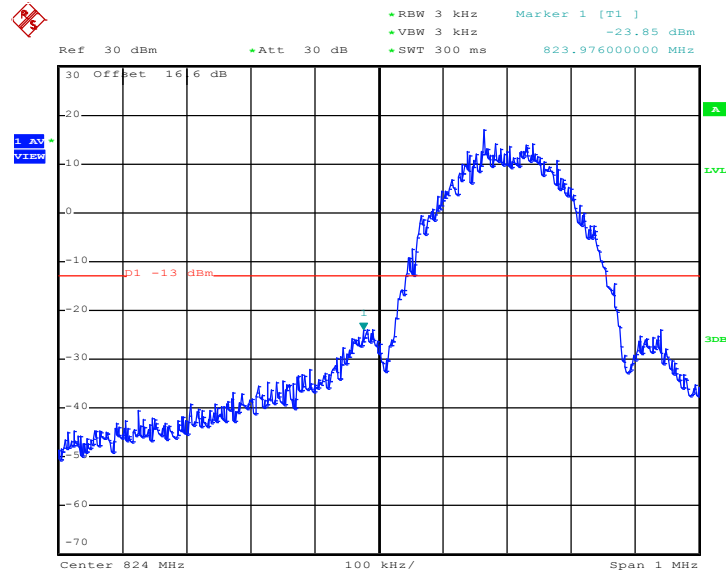

Date: 1.NOV.2013 21:44:33

1. Correction Factor(dB)= $10\log(1\% \text{ Emission BW/RBW})$
2. Band Edge= Measurement Value + Correction Factor(dB)
3. The total loss is 16.60 dB of the RF cable and attenuator, and has been compensated to the spectrum analyzer offset.



Band :	GSM850	Test Mode :	EDGE class 8 Link (8PSK)
Correction Factor :	0.11dB	Maximum 26dB Bandwidth :	0.308MHz
Band Edge :	-23.16dBm	Measurement Value :	-23.27dBm

Higher Band Edge Plot on Channel 251 (848.8 MHz)

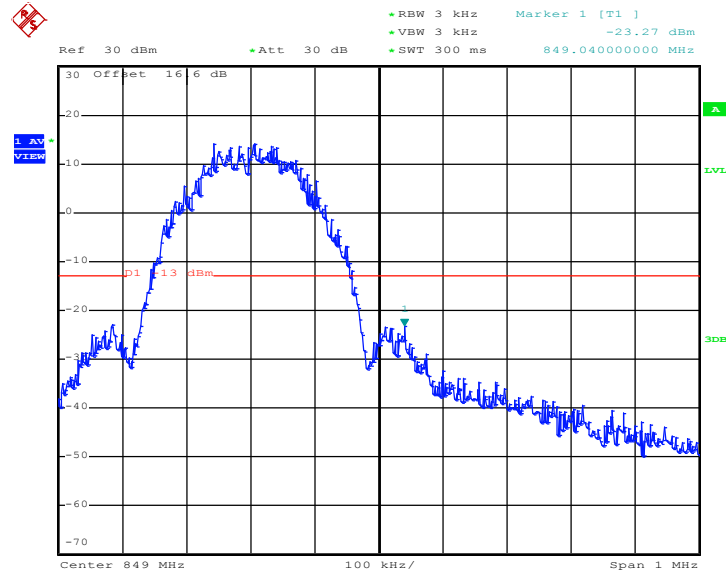

Date: 1.NOV.2013 21:43:07

1. Correction Factor(dB)= 10log(1% Emission BW/RBW)
2. Band Edge= Measurement Value + Correction Factor(dB)
3. The total loss is 16.60 dB of the RF cable and attenuator, and has been compensated to the spectrum analyzer offset.



Band :	GSM1900	Test Mode :	GPRS class 8 Link (GMSK)
Correction Factor :	0.20dB	Maximum 26dB Bandwidth :	0.314MHz
Band Edge :	-17.74dBm	Measurement Value :	-17.94dBm

Lower Band Edge Plot on Channel 512 (1850.2 MHz)

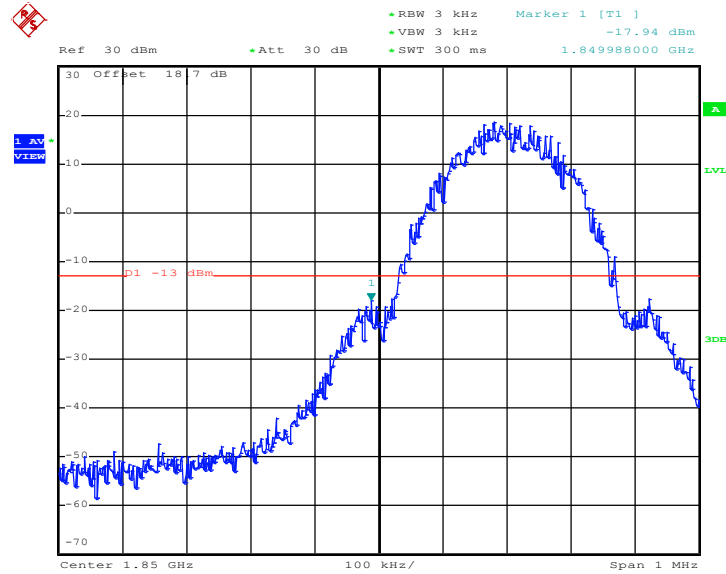

Date: 1.NOV.2013 21:20:51

1. Correction Factor(dB)= 10log(1% Emission BW/RBW)
2. Band Edge= Measurement Value + Correction Factor(dB)
3. The total loss is 18.70 dB of the RF cable and attenuator, and has been compensated to the spectrum analyzer offset.



Band :	GSM1900	Test Mode :	GPRS class 8 Link (GMSK)
Correction Factor :	0.20dB	Maximum 26dB Bandwidth :	0.314MHz
Band Edge :	-18.95dBm	Measurement Value :	-19.15dBm

Higher Band Edge Plot on Channel 810 (1909.8 MHz)

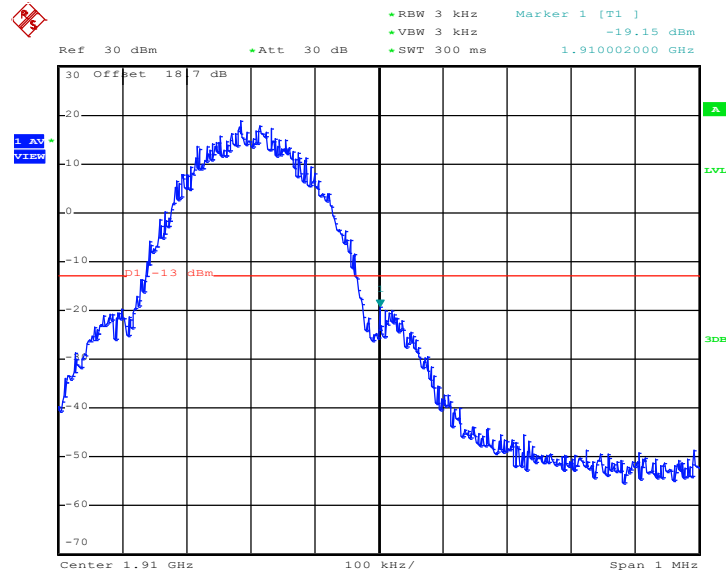

Date: 1.NOV.2013 21:18:02

1. Correction Factor(dB)= $10\log(1\% \text{ Emission BW/RBW})$
2. Band Edge= Measurement Value + Correction Factor(dB)
3. The total loss is 18.70 dB of the RF cable and attenuator, and has been compensated to the spectrum analyzer offset.



Band :	GSM1900	Test Mode :	EDGE class 8 Link (8PSK)
Correction Factor :	0.17dB	Maximum 26dB Bandwidth :	0.312MHz
Band Edge :	-22.75dBm	Measurement Value :	-22.92dBm

Lower Band Edge Plot on Channel 512 (1850.2 MHz)

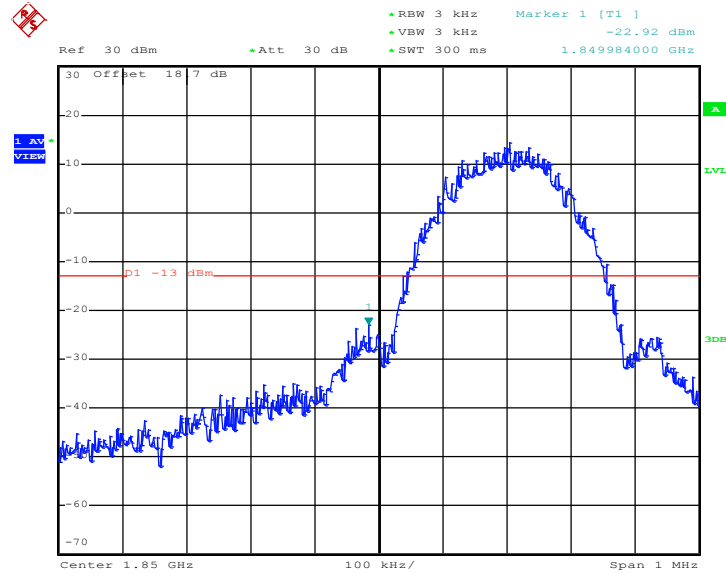

Date: 1.NOV.2013 21:08:05

1. Correction Factor(dB)= 10log(1% Emission BW/RBW)
2. Band Edge= Measurement Value + Correction Factor(dB)
3. The total loss is 18.70 dB of the RF cable and attenuator, and has been compensated to the spectrum analyzer offset.



Band :	GSM1900	Test Mode :	EDGE class 8 Link (8PSK)
Correction Factor :	0.17dB	Maximum 26dB Bandwidth :	0.312MHz
Band Edge :	-23.62dBm	Measurement Value :	-23.79dBm

Higher Band Edge Plot on Channel 810 (1909.8 MHz)

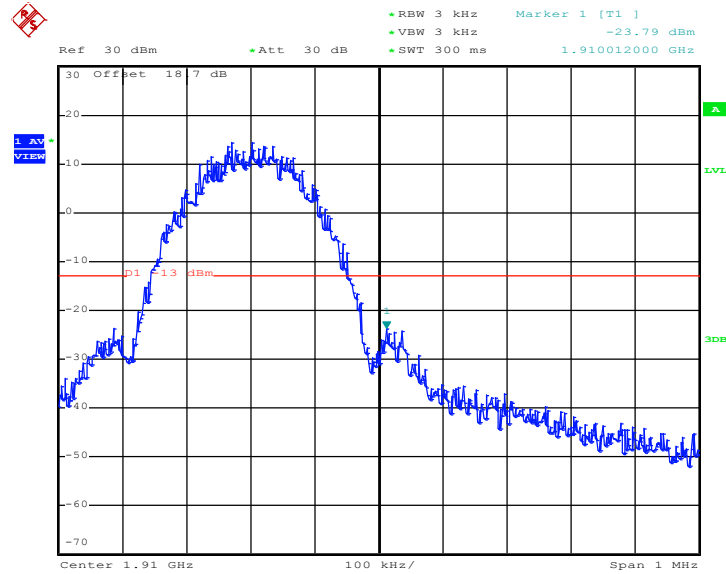

Date: 1.NOV.2013 21:06:10

1. Correction Factor(dB)= $10\log(1\% \text{ Emission BW/RBW})$
2. Band Edge= Measurement Value + Correction Factor(dB)
3. The total loss is 18.70 dB of the RF cable and attenuator, and has been compensated to the spectrum analyzer offset.



Band :	WCDMA Band V	Test Mode :	RMC 12.2Kbps Link (QPSK)
Correction Factor :	-3.21dB	Maximum 26dB Bandwidth :	4.78MHz
Band Edge :	-24.56dBm	Measurement Value :	-21.35dBm

Lower Band Edge Plot on Channel 4132 (826.4 MHz)

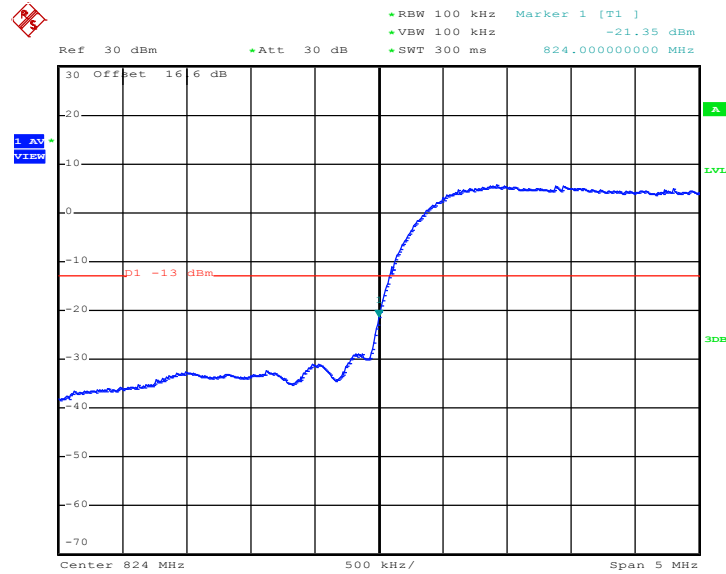

Date: 1.NOV.2013 22:23:43

1. Correction Factor(dB)= $10\log(1\% \text{ Emission BW/RBW})$
2. Band Edge= Measurement Value + Correction Factor(dB)
3. The total loss is 16.60 dB of the RF cable and attenuator, and has been compensated to the spectrum analyzer offset.



Band :	WCDMA Band V	Test Mode :	RMC 12.2Kbps Link (QPSK)
Correction Factor :	-3.21dB	Maximum 26dB Bandwidth :	4.78MHz
Band Edge :	-24.84dBm	Measurement Value :	-21.63dBm

Higher Band Edge Plot on Channel 4233 (846.6 MHz)

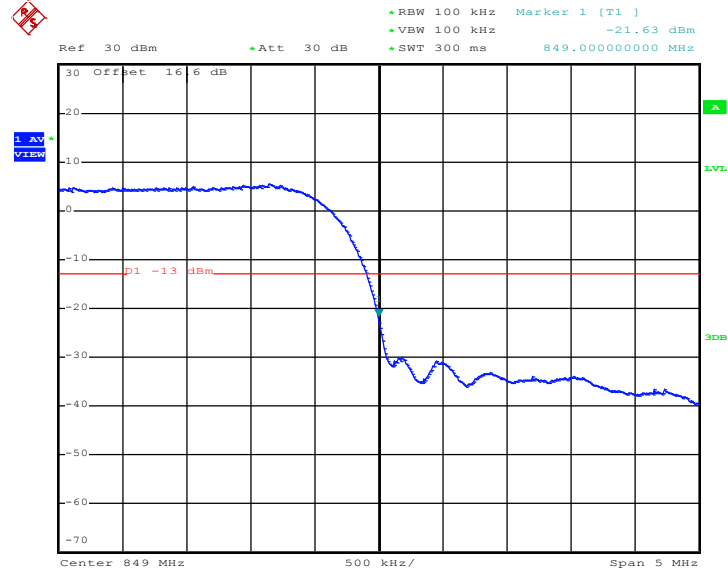

Date: 1.NOV.2013 22:24:10

1. Correction Factor(dB)= $10\log(1\% \text{ Emission BW/RBW})$
2. Band Edge= Measurement Value + Correction Factor(dB)
3. The total loss is 16.60 dB of the RF cable and attenuator, and has been compensated to the spectrum analyzer offset.



Band :	WCDMA Band II	Test Mode :	RMC 12.2Kbps Link (QPSK)
Correction Factor :	-3.22dB	Maximum 26dB Bandwidth :	4.76MHz
Band Edge :	-26.92dBm	Measurement Value :	-23.70dBm

Lower Band Edge Plot on Channel 9262 (1852.4 MHz)

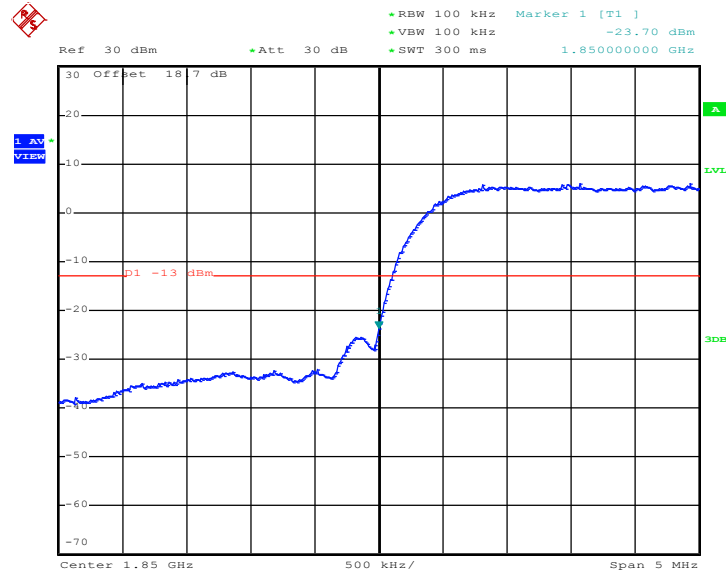

Date: 1.NOV.2013 22:15:56

1. Correction Factor(dB)= $10\log(1\% \text{ Emission BW/RBW})$
2. Band Edge= Measurement Value + Correction Factor(dB)
3. The total loss is 18.70 dB of the RF cable and attenuator, and has been compensated to the spectrum analyzer offset.



Band :	WCDMA Band II	Test Mode :	RMC 12.2Kbps Link (QPSK)
Correction Factor :	-3.22dB	Maximum 26dB Bandwidth :	4.76MHz
Band Edge :	-26.33dBm	Measurement Value :	-23.11dBm

Higher Band Edge Plot on Channel 9538 (1907.6 MHz)

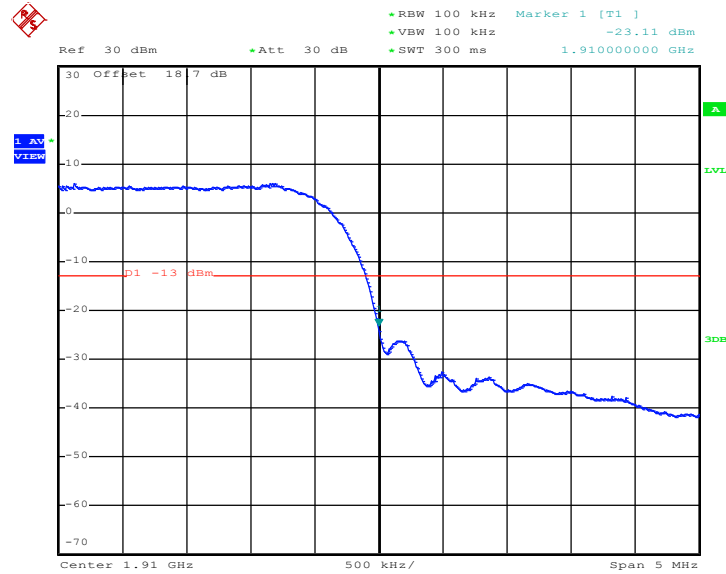

Date: 1.NOV.2013 22:16:23

1. Correction Factor(dB)= 10log(1% Emission BW/RBW)
2. Band Edge= Measurement Value + Correction Factor(dB)
3. The total loss is 18.70 dB of the RF cable and attenuator, and has been compensated to the spectrum analyzer offset.

3.6 Conducted Spurious Emission Measurement

3.6.1 Description of Conducted Spurious Emission Measurement

The power of any emission outside of the authorized operating frequency ranges must be lower than the transmitter power (P) by a factor of at least $43 + 10 \log (P)$ dB.

It is measured by means of a calibrated spectrum analyzer and scanned from 30 MHz up to a frequency including its 10th harmonic.

3.6.2 Measuring Instruments

The measuring equipment is listed in the section 4 of this test report.

3.6.3 Test Procedures

1. The EUT was connected to spectrum analyzer and base station via power divider.
2. The RF output of EUT was connected to the spectrum analyzer by RF cable and attenuator. The path loss was compensated to the results for each measurement.
3. The middle channel for the highest RF power within the transmitting frequency was measured.
4. The conducted spurious emission for the whole frequency range was taken.
5. The RF fundamental frequency should be excluded against the limit line in the operating frequency band.
6. The limit line is derived from $43 + 10\log(P)$ dB below the transmitter power P(Watts)

$$= P(W) - [43 + 10\log(P)] \text{ (dB)}$$

$$= [30 + 10\log(P)] \text{ (dBm)} - [43 + 10\log(P)] \text{ (dB)}$$

$$= -13\text{dBm}$$

3.6.4 Test Setup

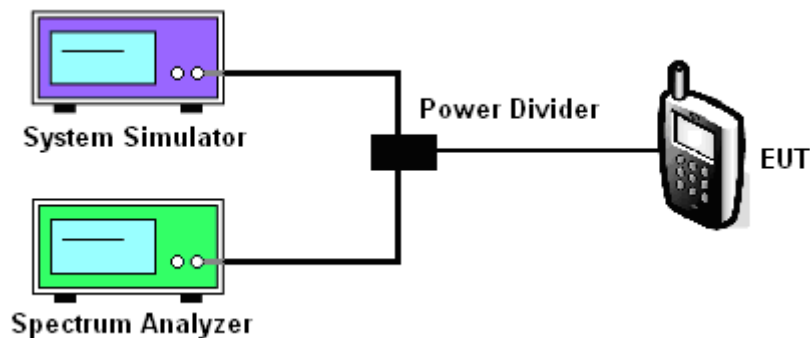



3.6.5 Test Result (Plots) of Conducted Spurious Emission

Band :	GSM850	Channel :	CH128
Test Mode :	GSM Link (GMSK)	Frequency :	824.2 MHz

Conducted Spurious Emission Plot between 30MHz ~ 1GHz

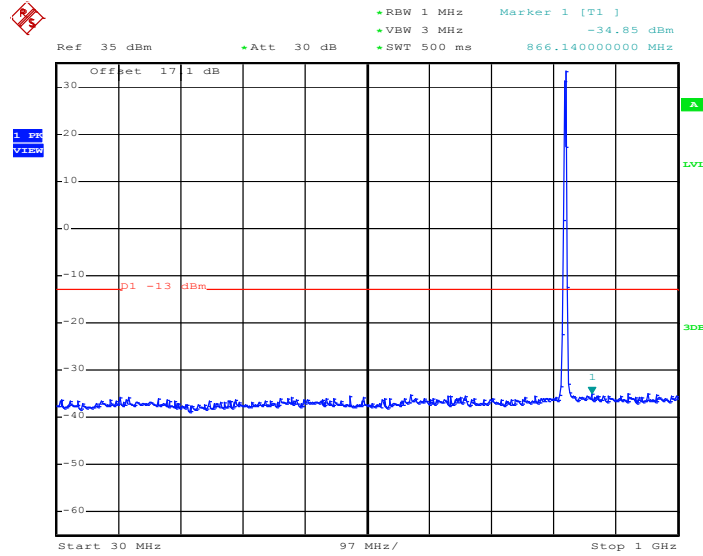

Date: 3.DEC.2013 21:03:21

Note: The RF fundamental frequency should be excluded against the limit line in the operating frequency band.



Conducted Spurious Emission Plot between 1GHz ~ 3GHz

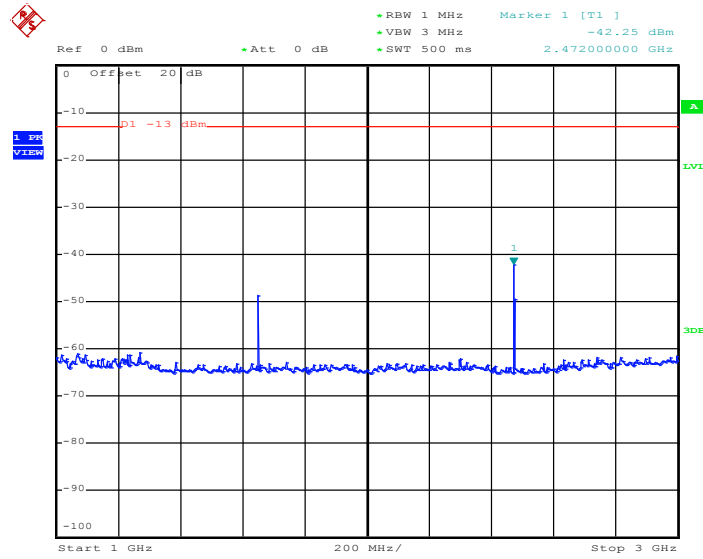

Date: 3.DEC.2013 21:03:35

Conducted Spurious Emission Plot between 3GHz ~ 7GHz

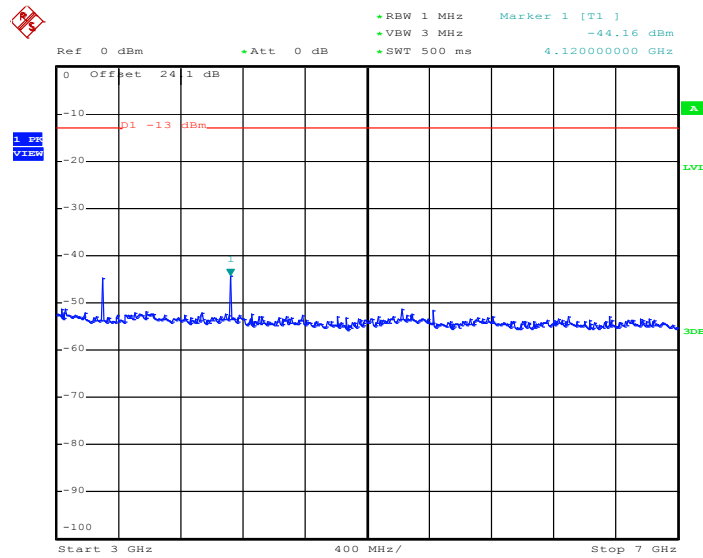

Date: 3.DEC.2013 21:03:44



Conducted Spurious Emission Plot between 7GHz ~ 9GHz

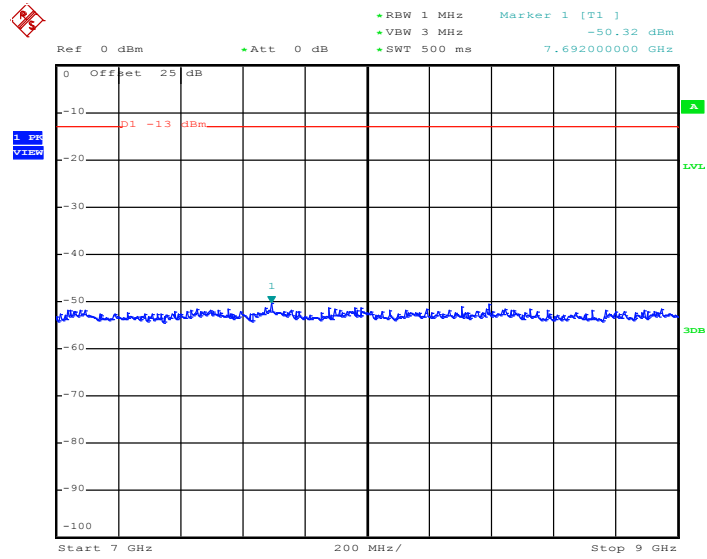

Date: 3.DEC.2013 21:03:54



Band :	GSM850	Channel :	CH189
Test Mode :	GSM Link (GMSK)	Frequency :	836.4 MHz

Conducted Spurious Emission Plot between 30MHz ~ 1GHz

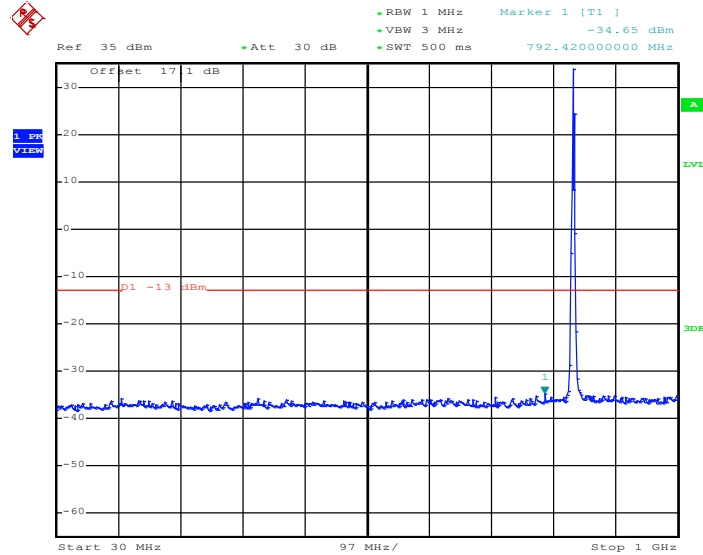

Date: 1.NOV.2013 22:00:22

Note: The RF fundamental frequency should be excluded against the limit line in the operating frequency band.



Conducted Spurious Emission Plot between 1GHz ~ 3GHz

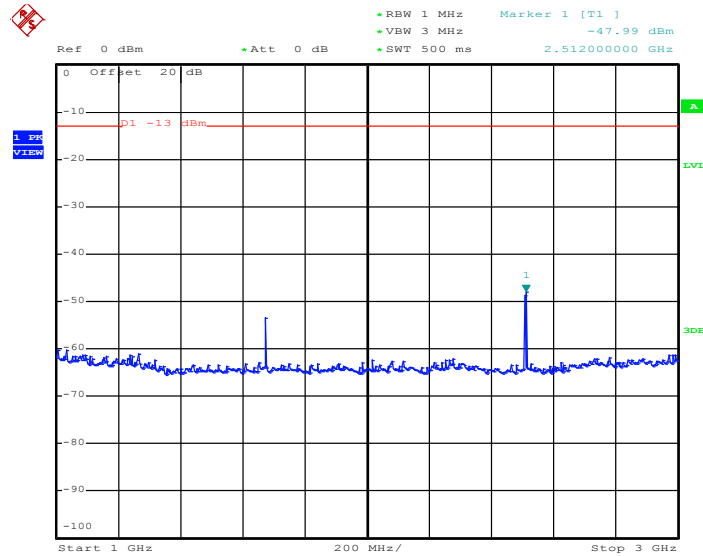

Date: 1.NOV.2013 22:00:37

Conducted Spurious Emission Plot between 3GHz ~ 7GHz

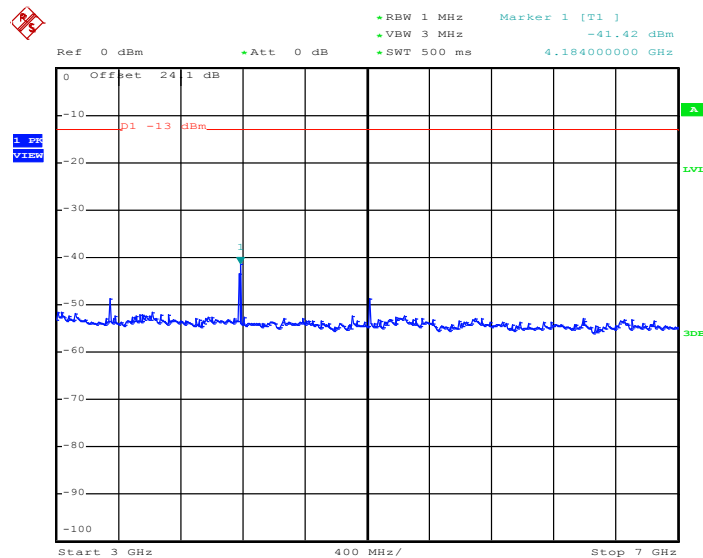

Date: 1.NOV.2013 22:00:50



Conducted Spurious Emission Plot between 7GHz ~ 9GHz

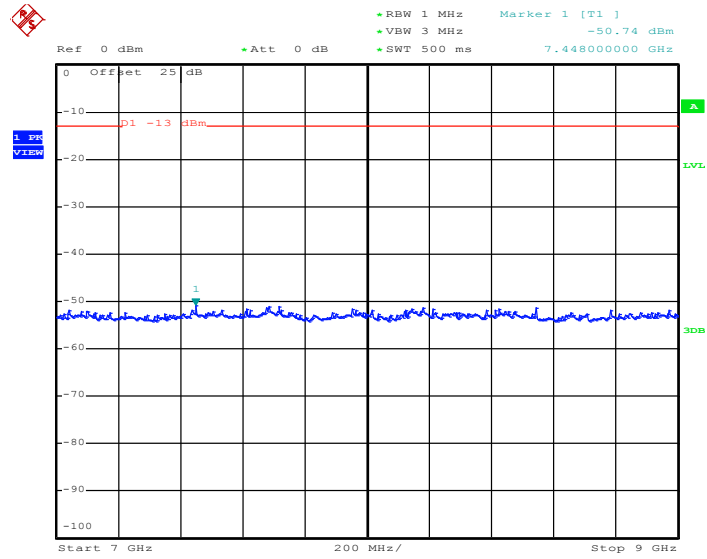

Date: 1.NOV.2013 22:01:02



Band :	GSM850	Channel :	CH251
Test Mode :	GSM Link (GMSK)	Frequency :	848.8 MHz

Conducted Spurious Emission Plot between 30MHz ~ 1GHz

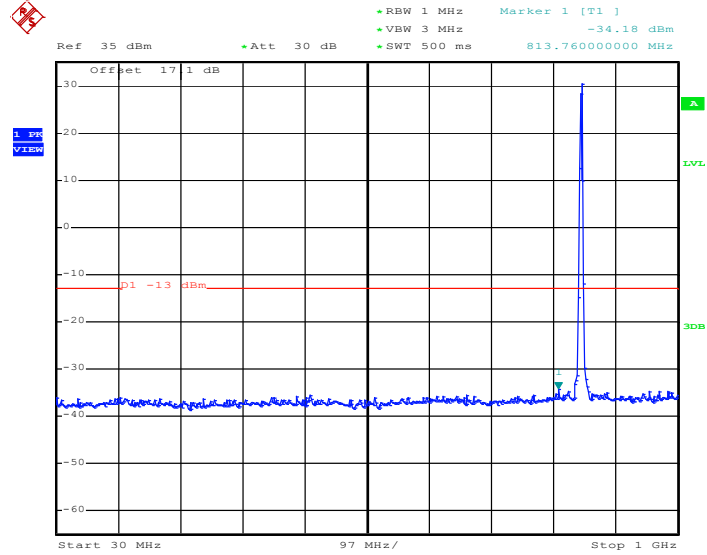

Date: 3.DEC.2013 21:08:04

Note: The RF fundamental frequency should be excluded against the limit line in the operating frequency band.



Conducted Spurious Emission Plot between 1GHz ~ 3GHz

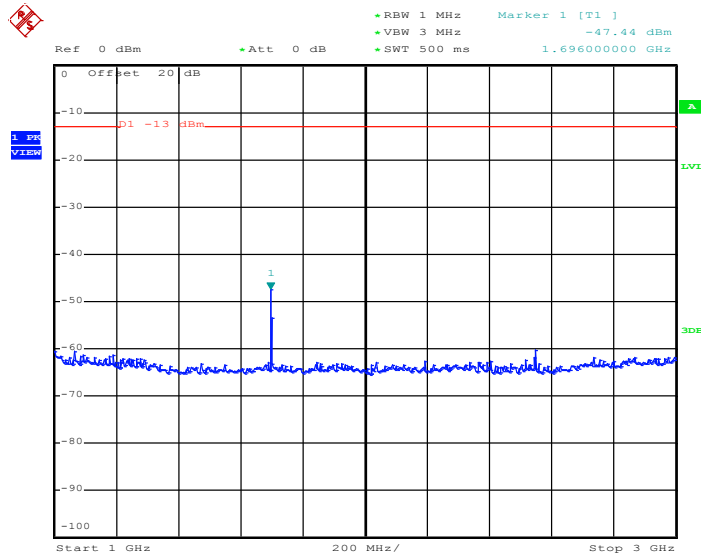

Date: 3.DEC.2013 21:08:23

Conducted Spurious Emission Plot between 3GHz ~ 7GHz

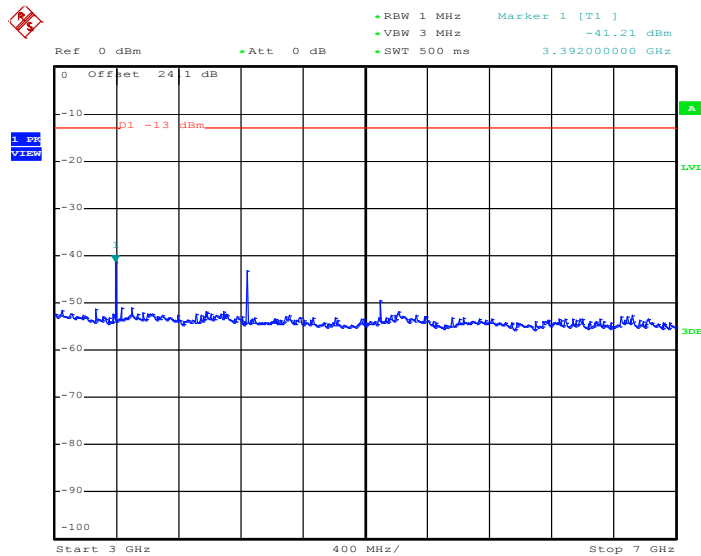

Date: 3.DEC.2013 21:08:33



Conducted Spurious Emission Plot between 7GHz ~ 9GHz

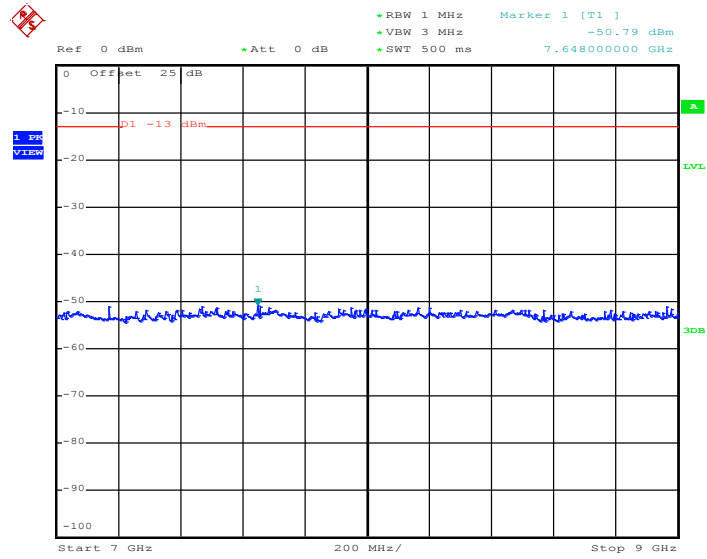

Date: 3.DEC.2013 21:08:43



Band :	GSM850	Channel :	CH128
Test Mode :	EDGE class 8 Link (8PSK)	Frequency :	824.2 MHz

Conducted Spurious Emission Plot between 30MHz ~ 1GHz

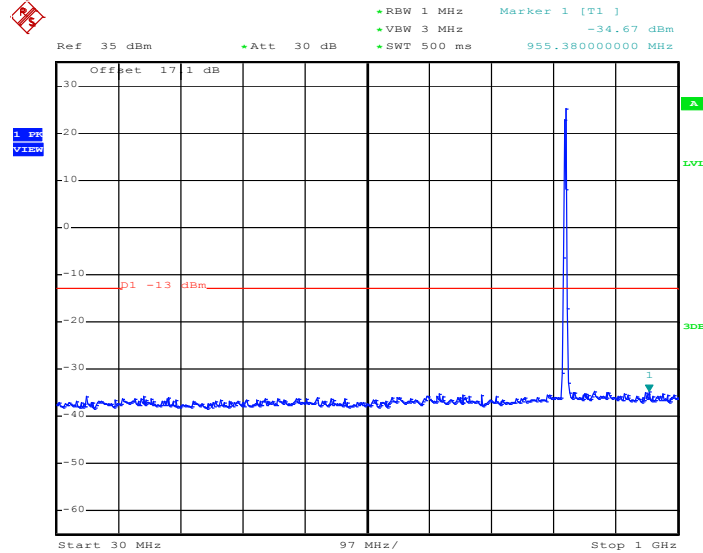

Date: 3.DEC.2013 21:13:17

Note: The RF fundamental frequency should be excluded against the limit line in the operating frequency band.



Conducted Spurious Emission Plot between 1GHz ~ 3GHz

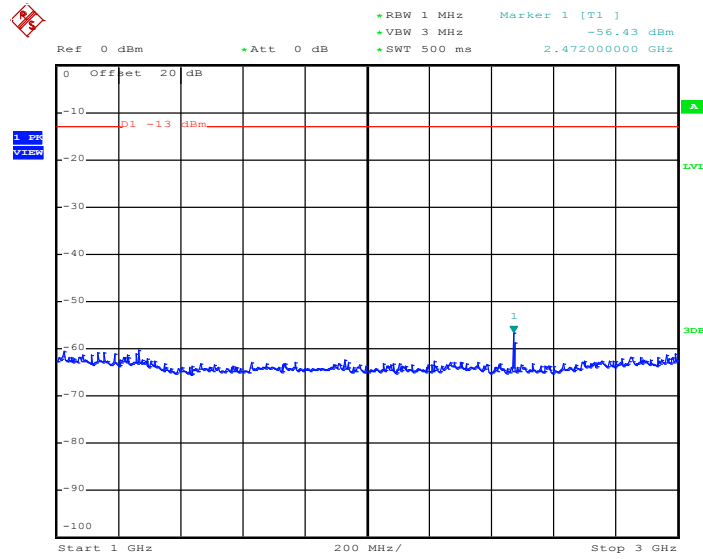

Date: 3.DEC.2013 21:13:30

Conducted Spurious Emission Plot between 3GHz ~ 7GHz

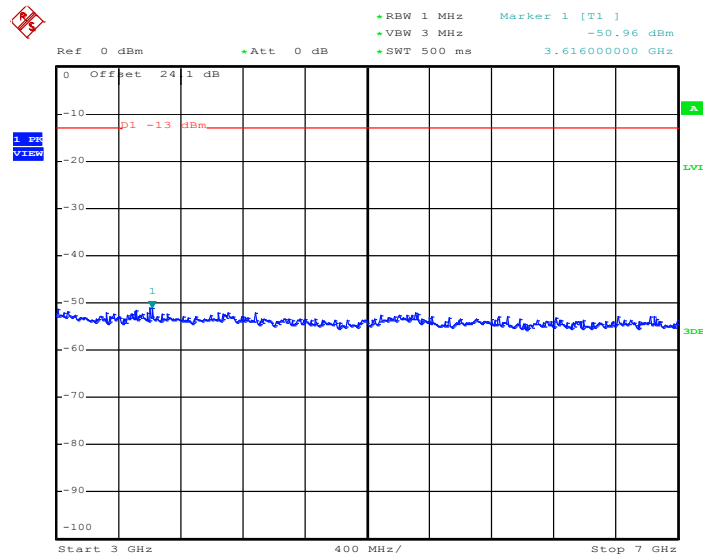

Date: 3.DEC.2013 21:13:40



Conducted Spurious Emission Plot between 7GHz ~ 9GHz

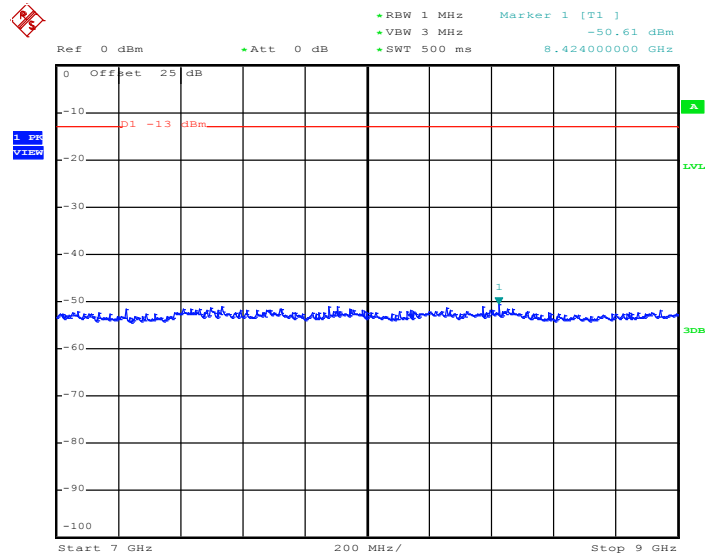

Date: 3.DEC.2013 21:13:50



Band :	GSM850	Channel :	CH189
Test Mode :	EDGE class 8 Link (8PSK)	Frequency :	836.4 MHz

Conducted Spurious Emission Plot between 30MHz ~ 1GHz

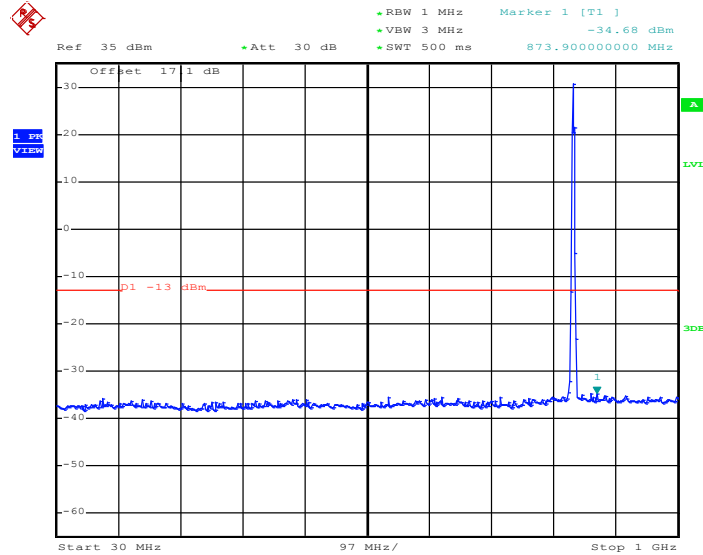

Date: 1.NOV.2013 21:37:43

Note: The RF fundamental frequency should be excluded against the limit line in the operating frequency band.



Conducted Spurious Emission Plot between 1GHz ~ 3GHz

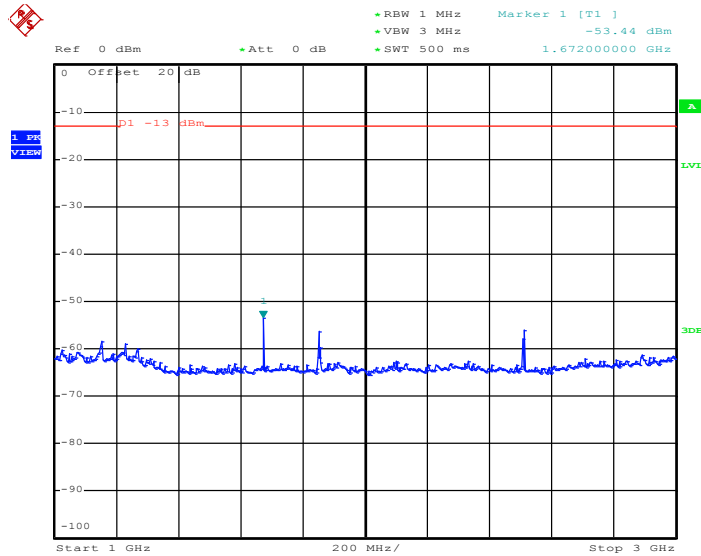

Date: 1.NOV.2013 21:37:58

Conducted Spurious Emission Plot between 3GHz ~ 7GHz

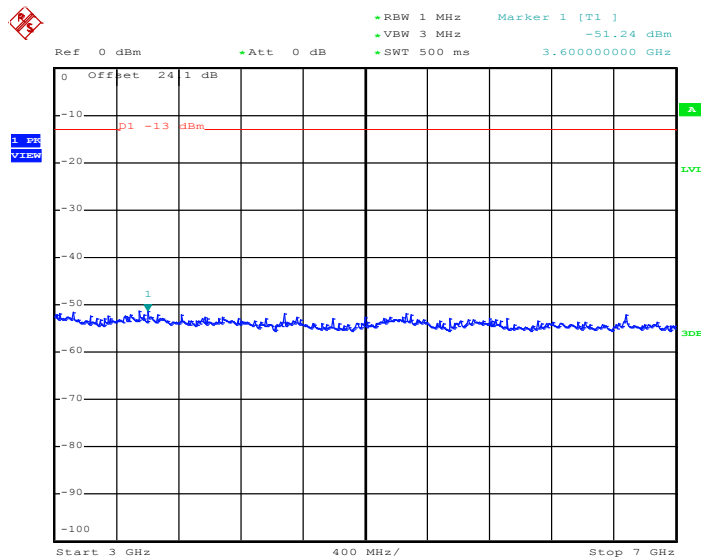

Date: 1.NOV.2013 21:38:11



Conducted Spurious Emission Plot between 7GHz ~ 9GHz

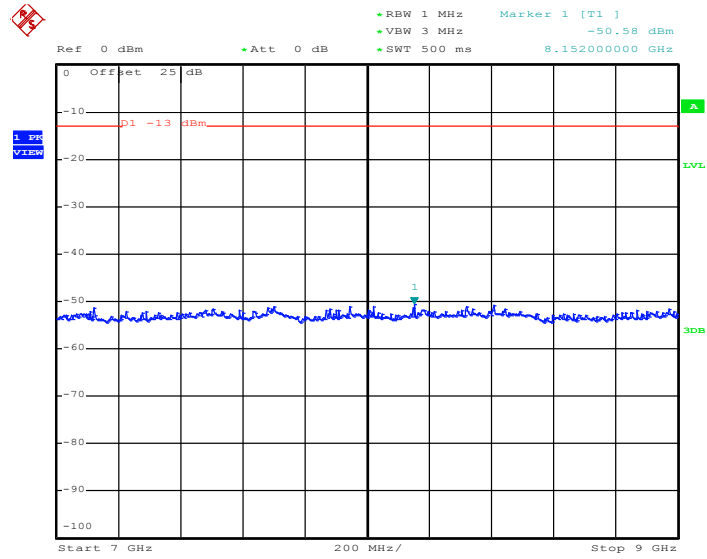

Date: 1.NOV.2013 21:38:23



Band :	GSM850	Channel :	CH251
Test Mode :	EDGE class 8 Link (8PSK)	Frequency :	848.8 MHz

Conducted Spurious Emission Plot between 30MHz ~ 1GHz

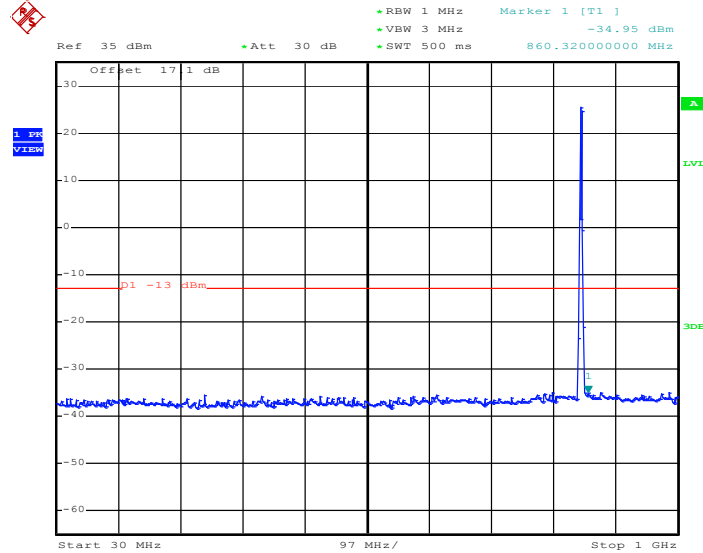

Date: 3.DEC.2013 21:14:42

Note: The RF fundamental frequency should be excluded against the limit line in the operating frequency band.



Conducted Spurious Emission Plot between 1GHz ~ 3GHz

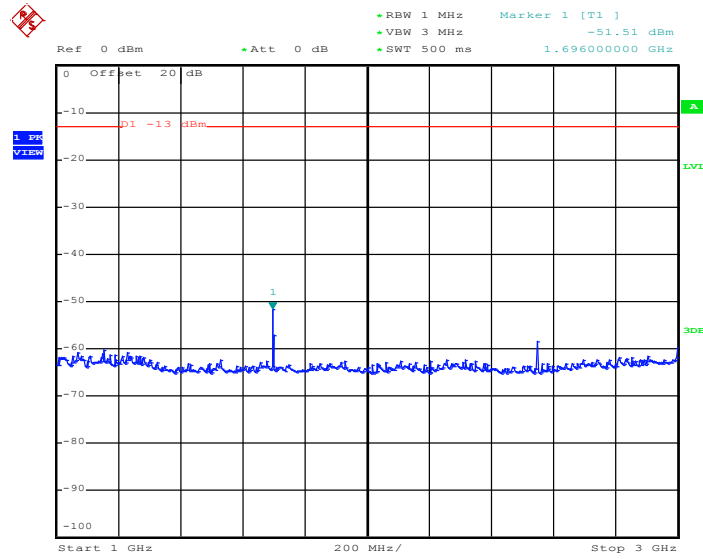

Date: 3.DEC.2013 21:14:56

Conducted Spurious Emission Plot between 3GHz ~ 7GHz

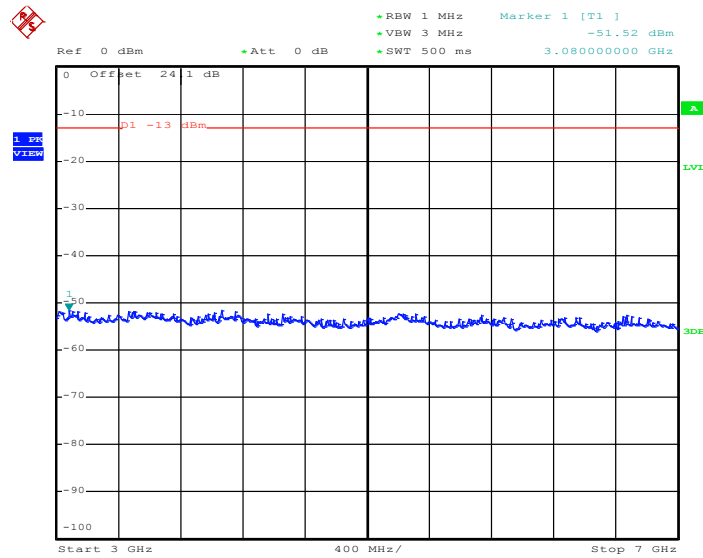

Date: 3.DEC.2013 21:15:05



Conducted Spurious Emission Plot between 7GHz ~ 9GHz

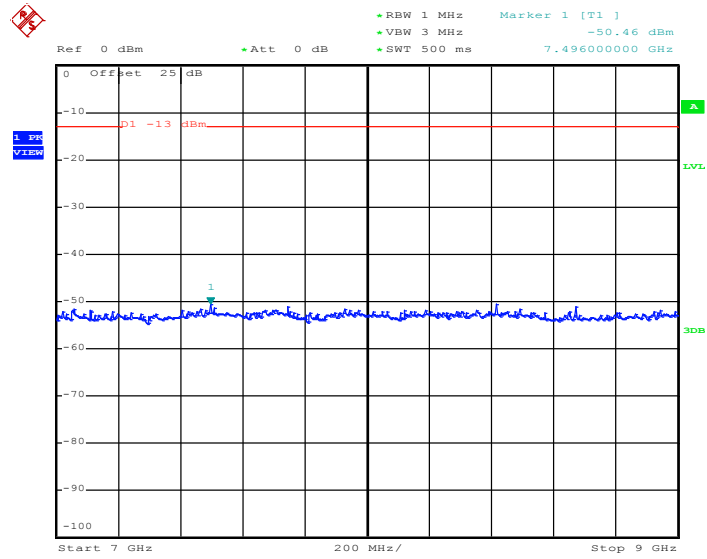

Date: 3.DEC.2013 21:15:15



Band :	GSM1900	Channel :	CH512
Test Mode :	GPRS class 8 Link (GMSK)	Frequency :	1850.2 MHz

Conducted Spurious Emission Plot between 30MHz ~ 1GHz

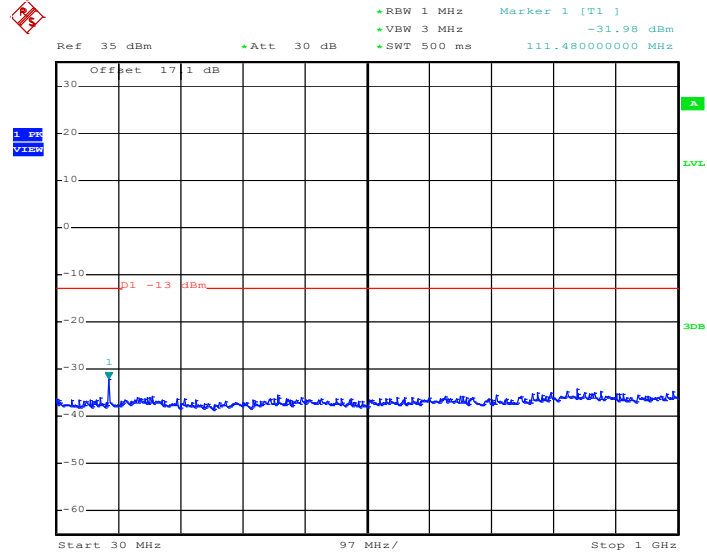

Date: 3.DEC.2013 21:20:36



Conducted Spurious Emission Plot between 1GHz ~ 3GHz

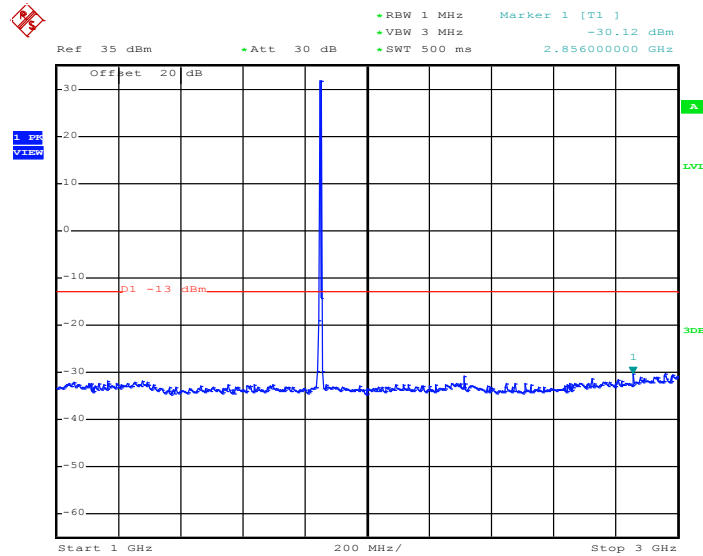

Date: 3.DEC.2013 21:20:45

Note: The RF fundamental frequency should be excluded against the limit line in the operating frequency band.

Conducted Spurious Emission Plot between 3GHz ~ 7GHz

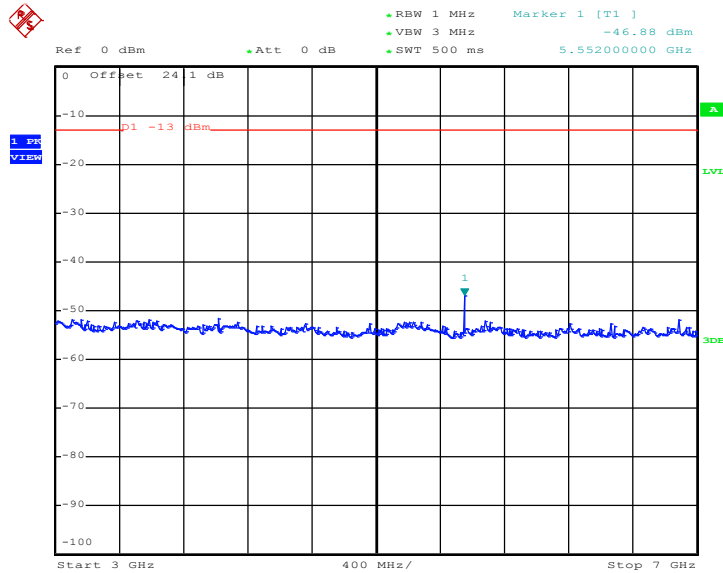

Date: 3.DEC.2013 21:20:58



Conducted Emission Plot between 7GHz ~ 13.6GHz

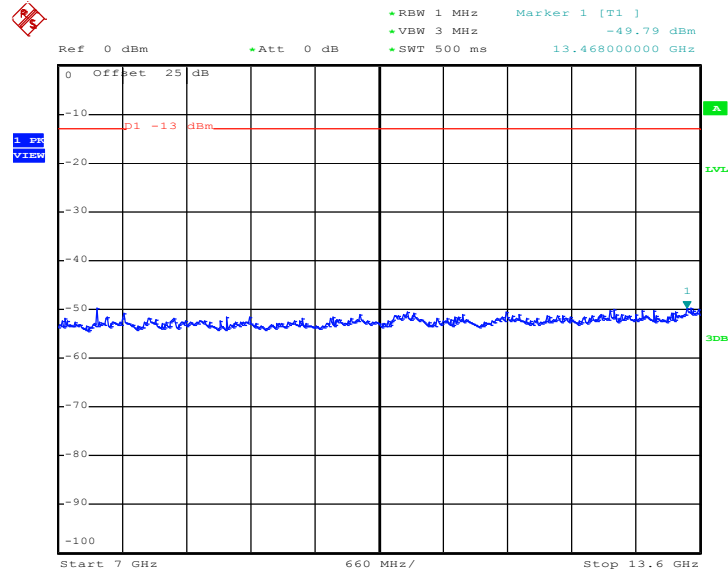

Date: 3.DEC.2013 21:21:08

Conducted Spurious Emission Plot between 13.6GHz ~ 19.1GHz

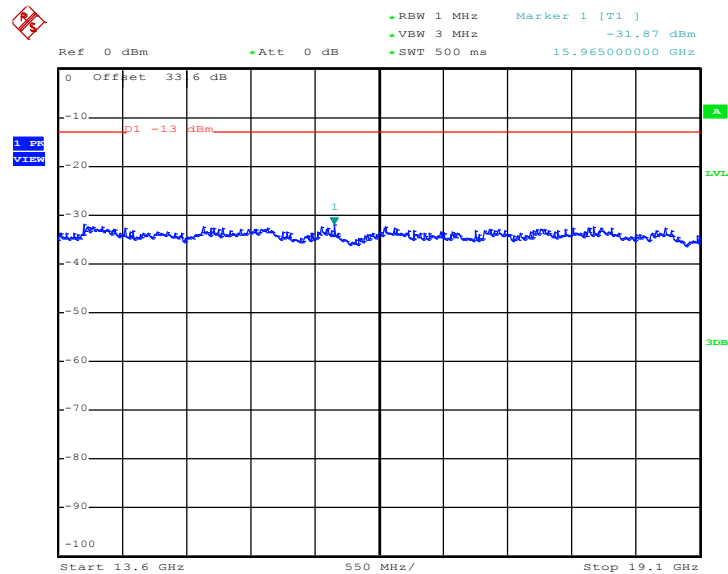

Date: 3.DEC.2013 21:21:18



Band :	GSM1900	Channel :	CH661
Test Mode :	GPRS class 8 Link (GMSK)	Frequency :	1880.0 MHz

Conducted Spurious Emission Plot between 30MHz ~ 1GHz

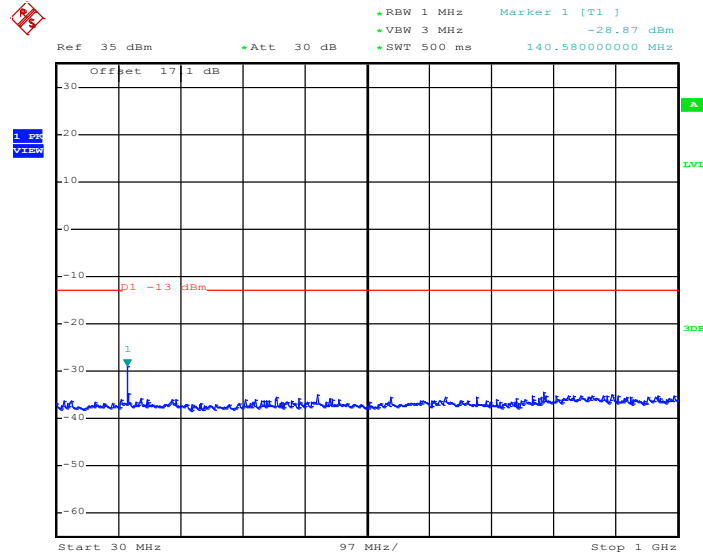

Date: 1.NOV.2013 21:13:21



Conducted Spurious Emission Plot between 1GHz ~ 3GHz

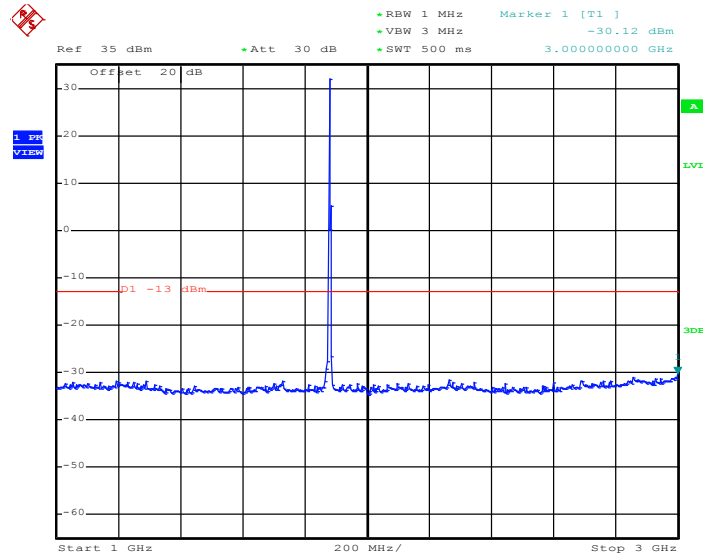

Date: 1.NOV.2013 21:13:34

Note: The RF fundamental frequency should be excluded against the limit line in the operating frequency band.

Conducted Spurious Emission Plot between 3GHz ~ 7GHz

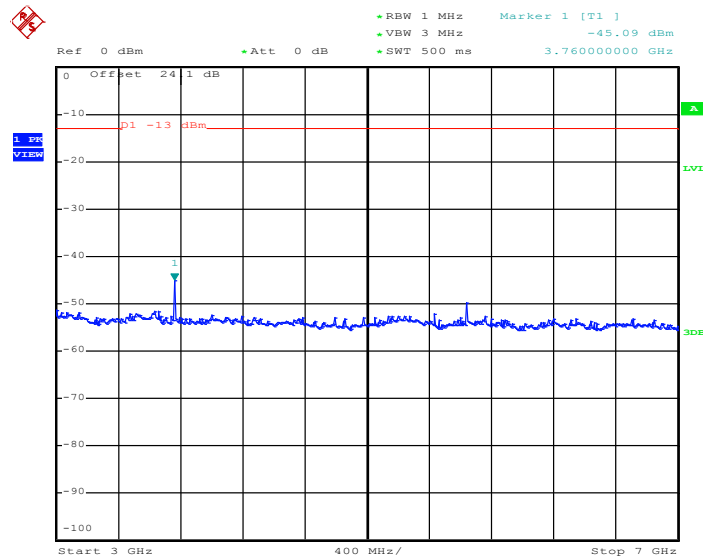

Date: 1.NOV.2013 21:13:51



Conducted Emission Plot between 7GHz ~ 13.6GHz

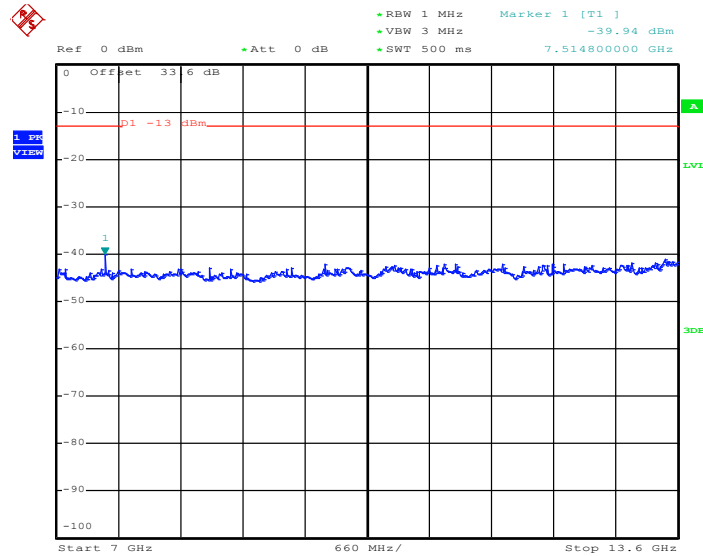

Date: 1.NOV.2013 21:14:03

Conducted Spurious Emission Plot between 13.6GHz ~ 19.1GHz

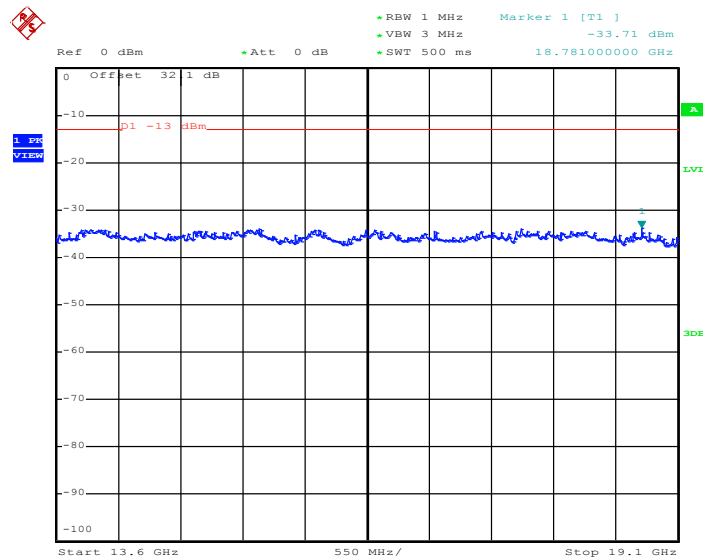

Date: 1.NOV.2013 21:14:16



Band :	GSM1900	Channel :	CH810
Test Mode :	GPRS class 8 Link (GMSK)	Frequency :	1909.8 MHz

Conducted Spurious Emission Plot between 30MHz ~ 1GHz

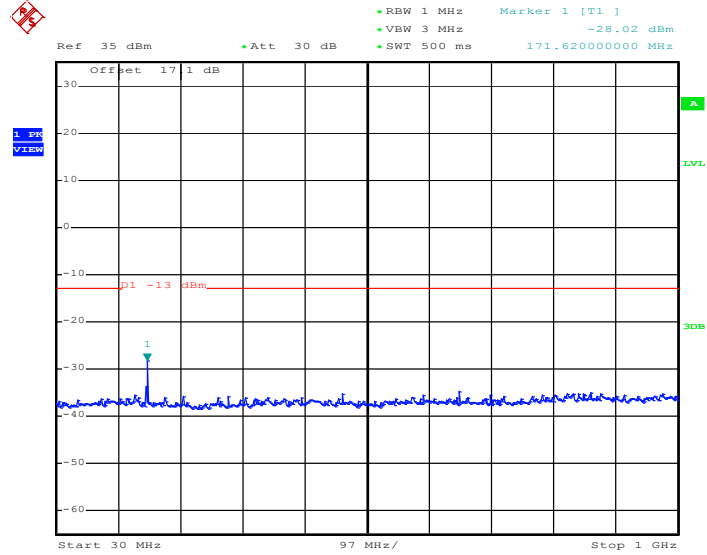

Date: 3.DEC.2013 21:22:14



Conducted Spurious Emission Plot between 1GHz ~ 3GHz

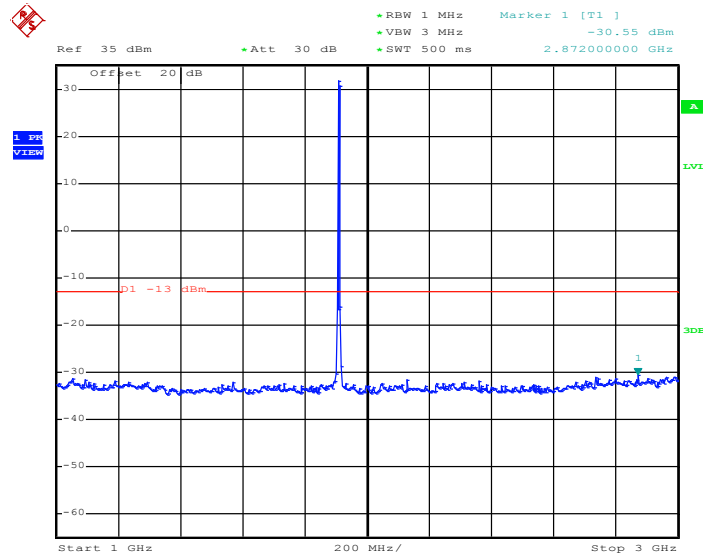

Date: 3.DEC.2013 21:22:24

Note: The RF fundamental frequency should be excluded against the limit line in the operating frequency band.

Conducted Spurious Emission Plot between 3GHz ~ 7GHz

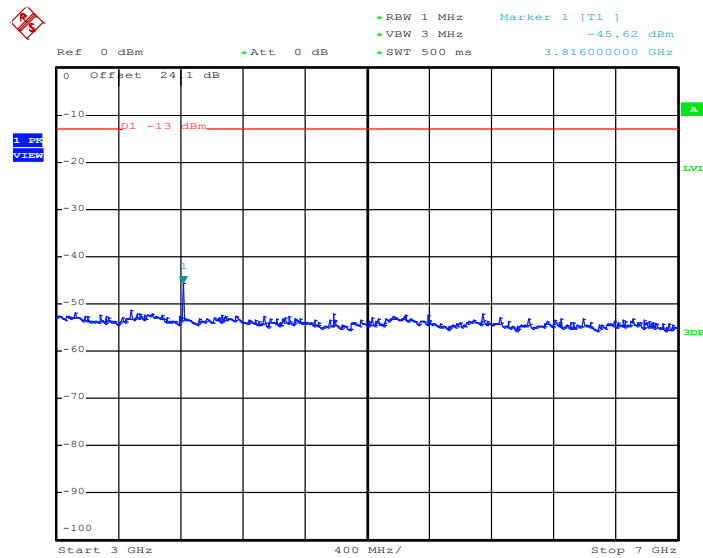

Date: 3.DEC.2013 21:22:37



Conducted Emission Plot between 7GHz ~ 13.6GHz

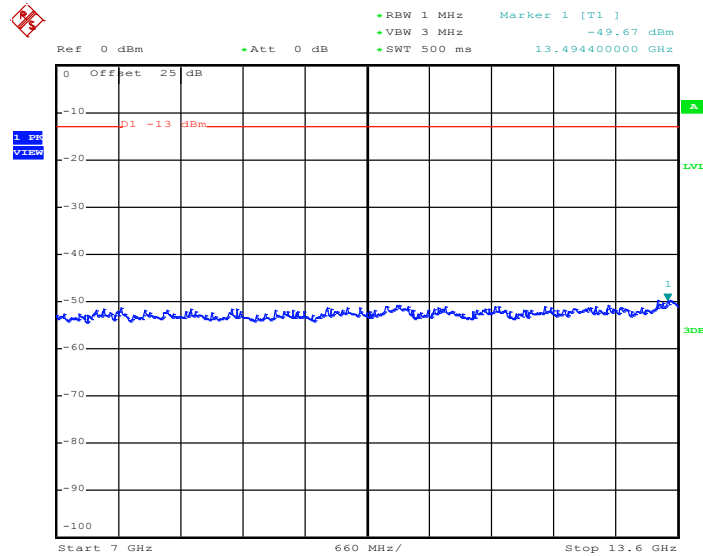

Date: 3.DEC.2013 21:22:47

Conducted Spurious Emission Plot between 13.6GHz ~ 19.1GHz

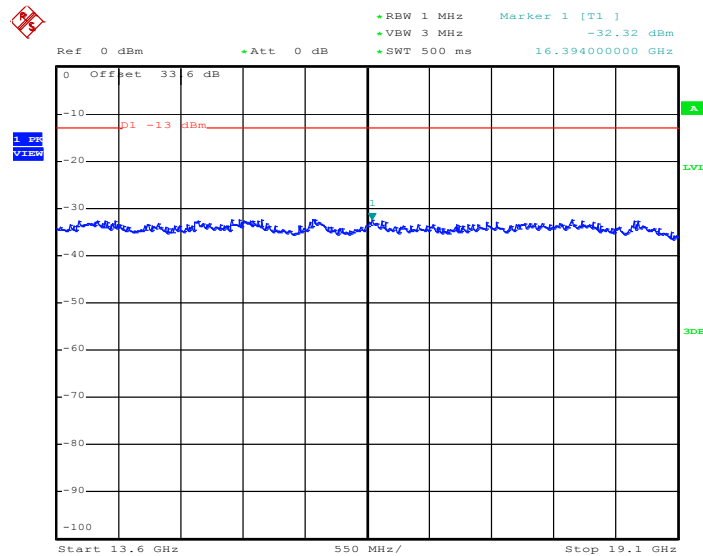

Date: 3.DEC.2013 21:22:56



Band :	GSM1900	Channel :	CH512
Test Mode :	EDGE class 8 Link (8PSK)	Frequency :	1850.2 MHz

Conducted Spurious Emission Plot between 30MHz ~ 1GHz

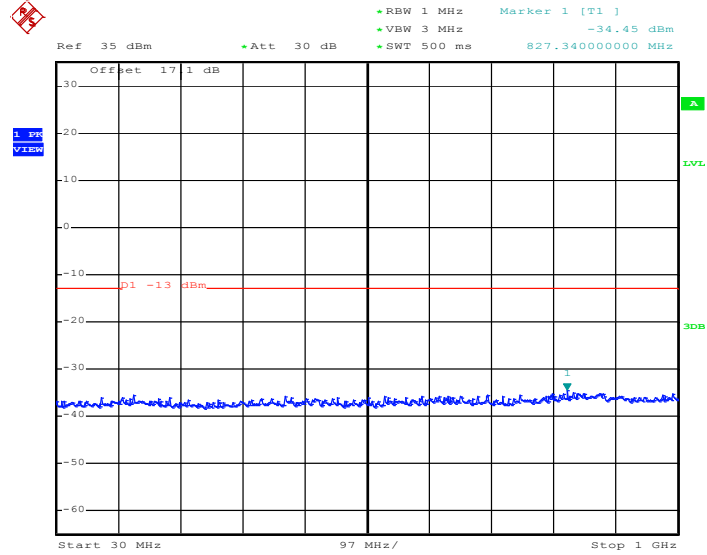

Date: 3.DEC.2013 21:26:30



Conducted Spurious Emission Plot between 1GHz ~ 3GHz

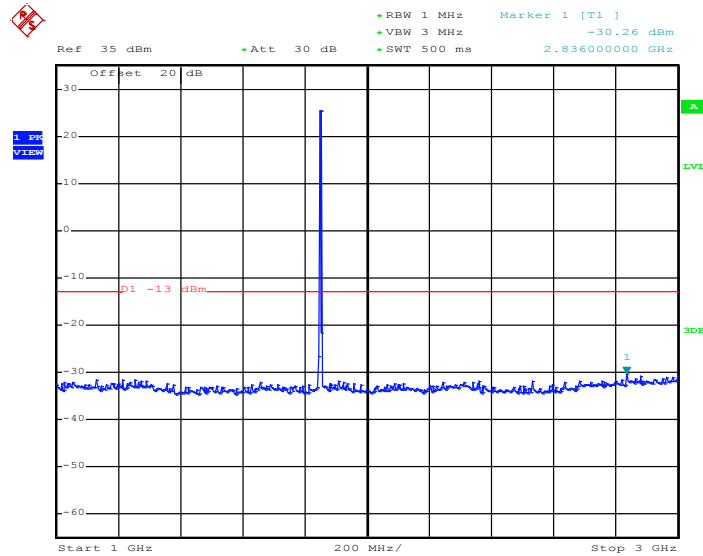

Date: 3.DEC.2013 21:26:40

Note: The RF fundamental frequency should be excluded against the limit line in the operating frequency band.

Conducted Spurious Emission Plot between 3GHz ~ 7GHz

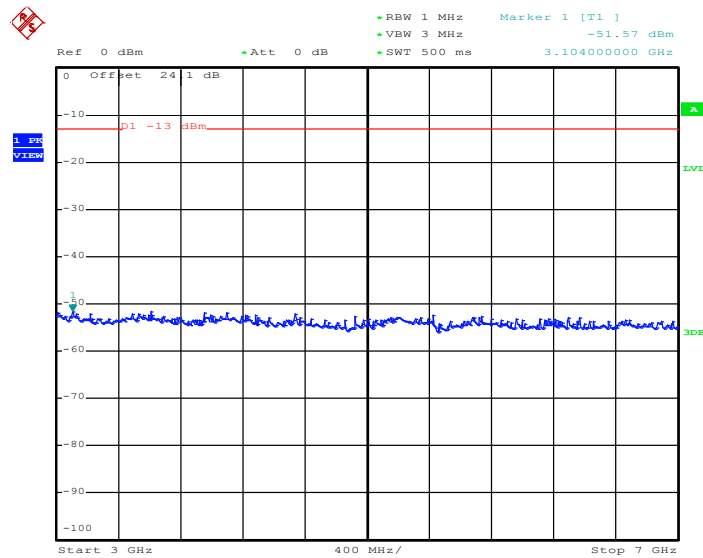

Date: 3.DEC.2013 21:26:54



Conducted Spurious Emission Plot between 7GHz ~ 13.6GHz

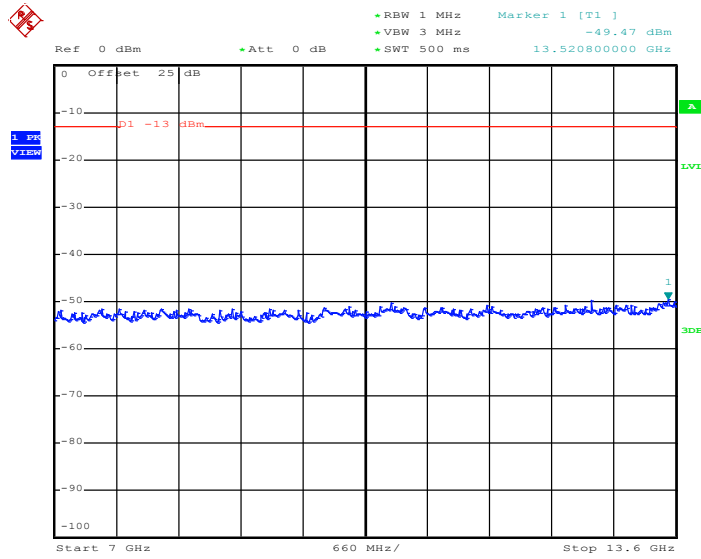

Date: 3.DEC.2013 21:27:04

Conducted Spurious Emission Plot between 13.6GHz ~ 19.1GHz

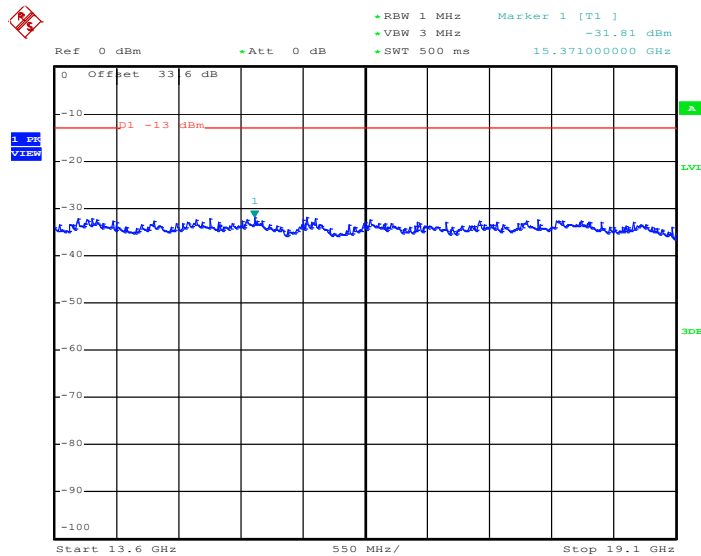

Date: 3.DEC.2013 21:27:14



Band :	GSM1900	Channel :	CH661
Test Mode :	EDGE class 8 Link (8PSK)	Frequency :	1880.0 MHz

Conducted Spurious Emission Plot between 30MHz ~ 1GHz

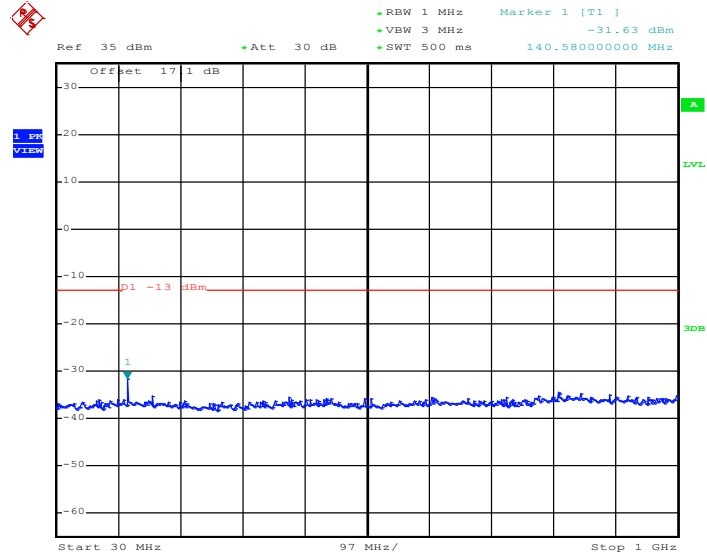

Date: 1.NOV.2013 20:59:58



Conducted Spurious Emission Plot between 1GHz ~ 3GHz

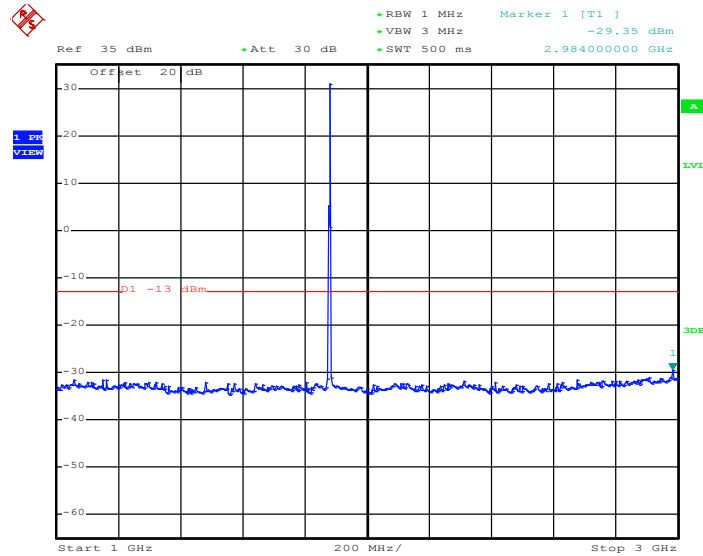

Date: 1.NOV.2013 21:00:10

Note: The RF fundamental frequency should be excluded against the limit line in the operating frequency band.

Conducted Spurious Emission Plot between 3GHz ~ 7GHz

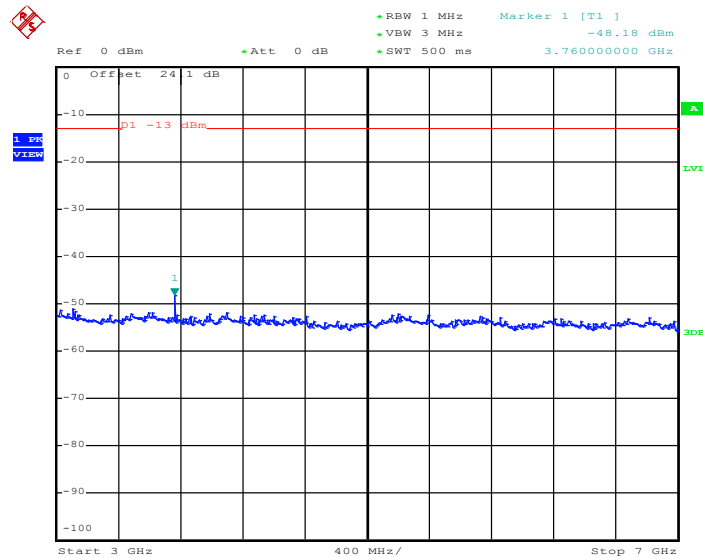

Date: 1.NOV.2013 21:00:27



Conducted Spurious Emission Plot between 7GHz ~ 13.6GHz

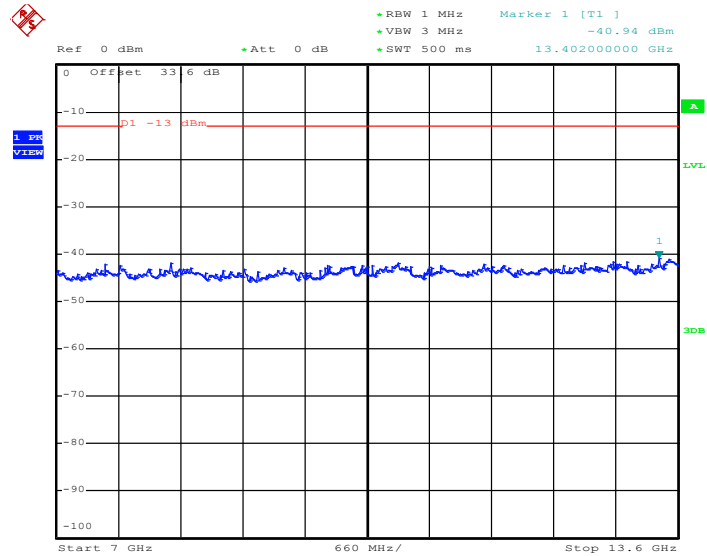

Date: 1.NOV.2013 21:00:40

Conducted Spurious Emission Plot between 13.6GHz ~ 19.1GHz

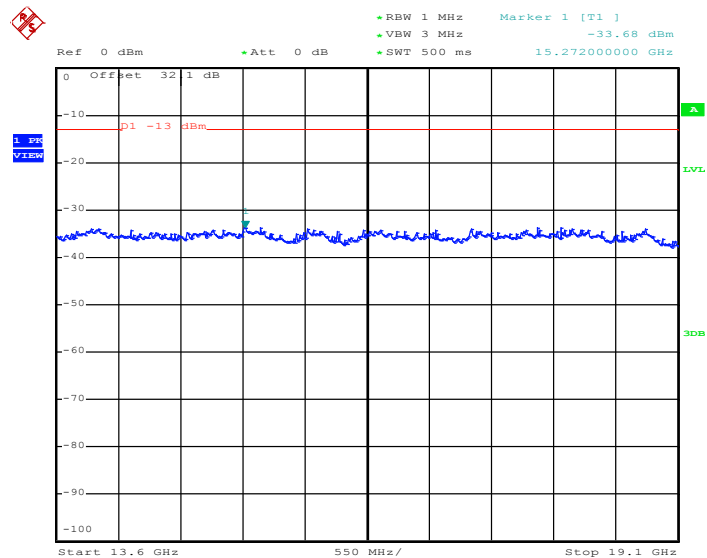

Date: 1.NOV.2013 21:00:52



Band :	GSM1900	Channel :	CH810
Test Mode :	EDGE class 8 Link (8PSK)	Frequency :	1909.8 MHz

Conducted Spurious Emission Plot between 30MHz ~ 1GHz

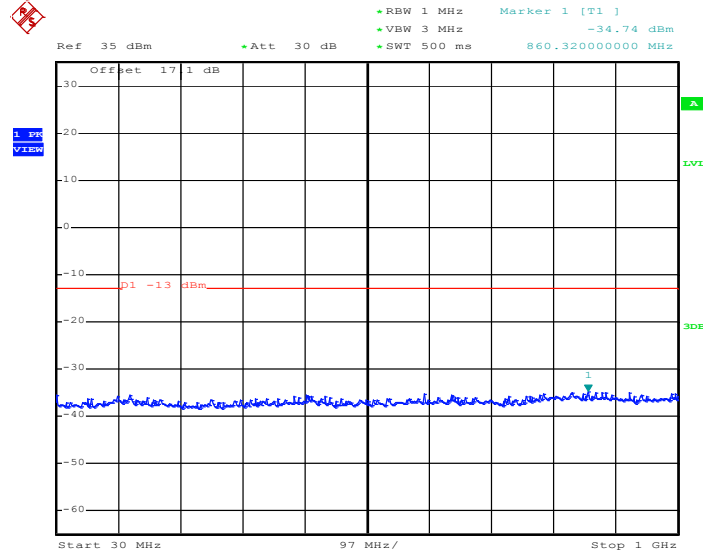

Date: 3.DEC.2013 21:28:02



Conducted Spurious Emission Plot between 1GHz ~ 3GHz

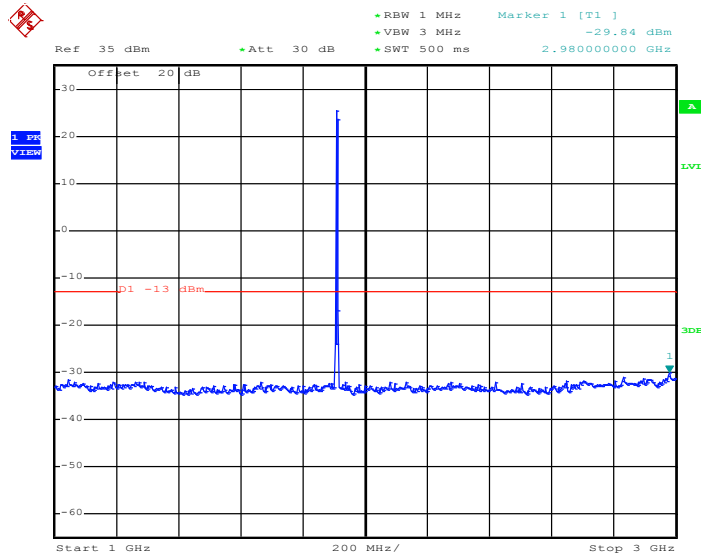

Date: 3.DEC.2013 21:28:12

Note: The RF fundamental frequency should be excluded against the limit line in the operating frequency band.

Conducted Spurious Emission Plot between 3GHz ~ 7GHz

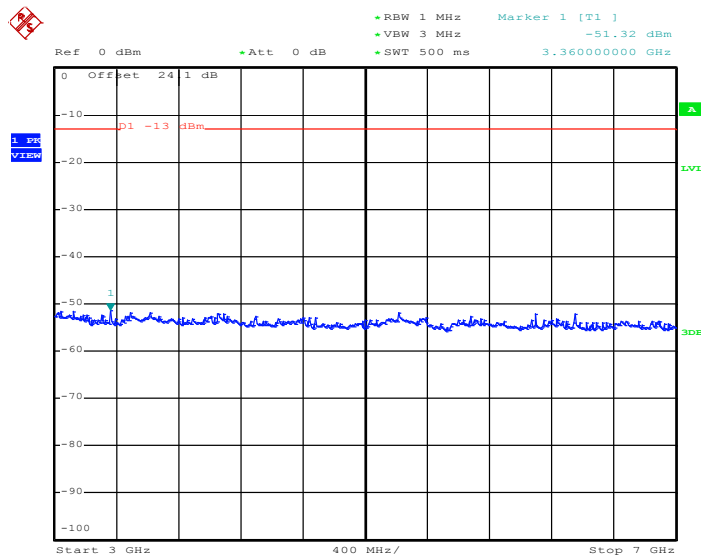

Date: 3.DEC.2013 21:28:24



Conducted Spurious Emission Plot between 7GHz ~ 13.6GHz

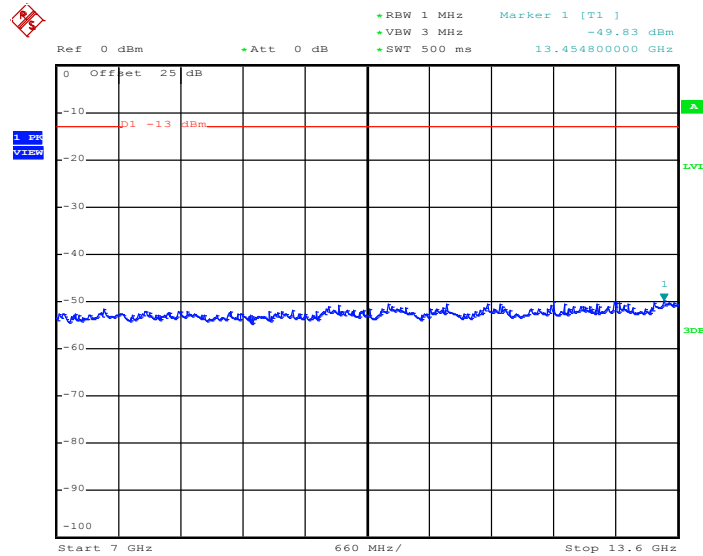

Date: 3.DEC.2013 21:28:34

Conducted Spurious Emission Plot between 13.6GHz ~ 19.1GHz

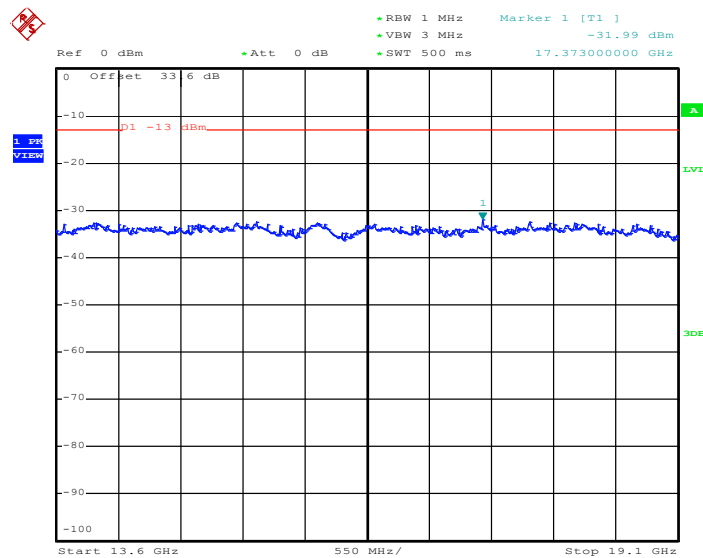

Date: 3.DEC.2013 21:28:44



Band :	WCDMA Band V	Channel :	CH4132
Test Mode :	RMC 12.2Kbps Link (QPSK)	Frequency :	826.4 MHz

Conducted Spurious Emission Plot between 30MHz ~ 1GHz

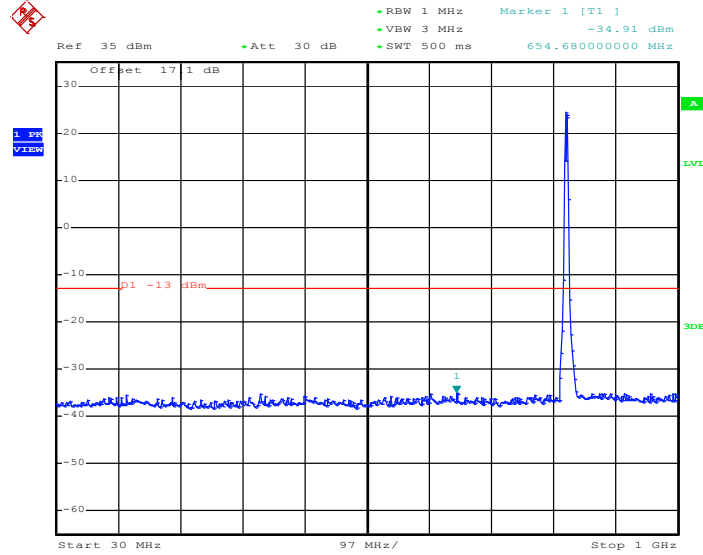

Date: 3.DEC.2013 21:40:22

Note: The RF fundamental frequency should be excluded against the limit line in the operating frequency band.



Conducted Spurious Emission Plot between 1GHz ~ 3GHz

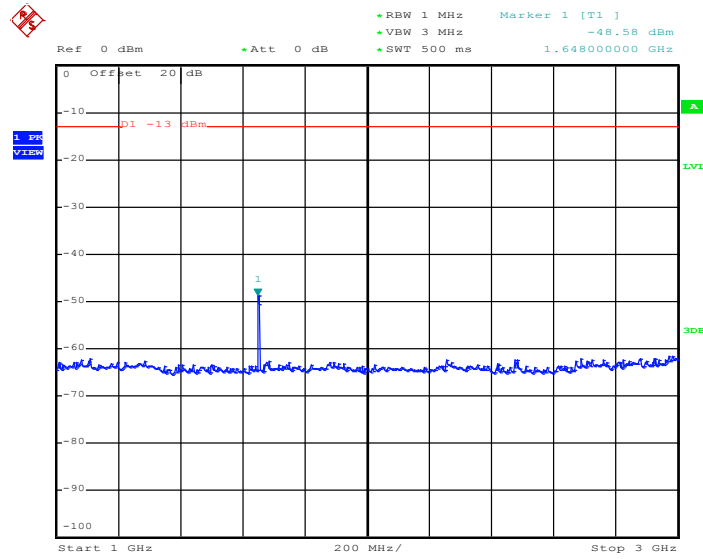

Date: 3.DEC.2013 21:40:36

Conducted Spurious Emission Plot between 3GHz ~ 7GHz

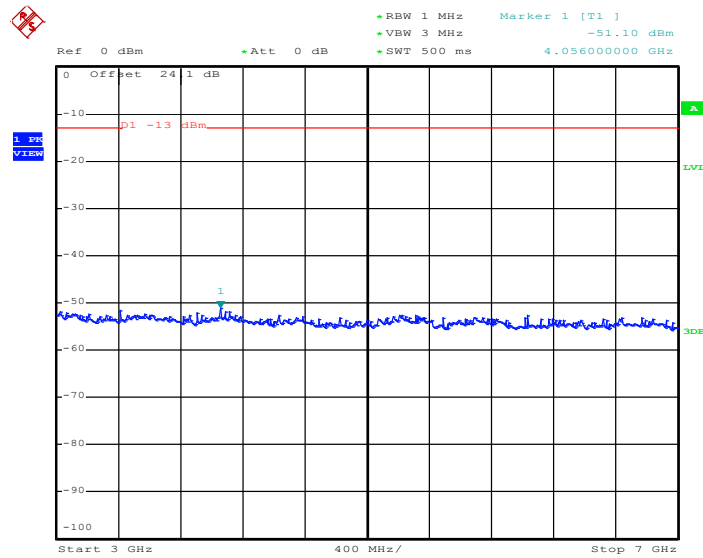

Date: 3.DEC.2013 21:40:45



Conducted Spurious Emission Plot between 7GHz ~ 9GHz

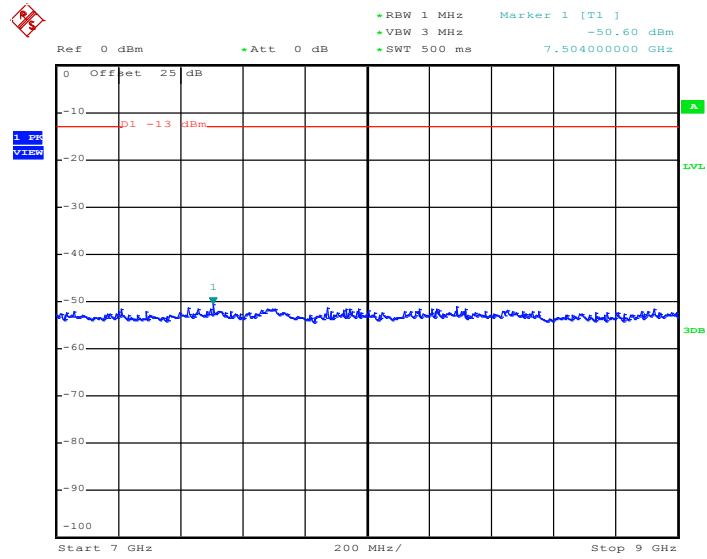

Date: 3.DEC.2013 21:40:55



Band :	WCDMA Band V	Channel :	CH4182
Test Mode :	RMC 12.2Kbps Link (QPSK)	Frequency :	836.4 MHz

Conducted Spurious Emission Plot between 30MHz ~ 1GHz

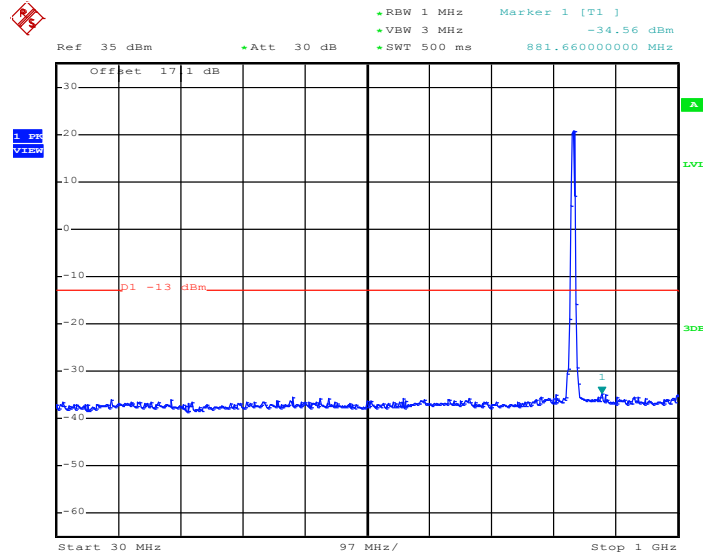

Date: 1.NOV.2013 22:19:44

Note: The RF fundamental frequency should be excluded against the limit line in the operating frequency band.



Conducted Spurious Emission Plot between 1GHz ~ 3GHz

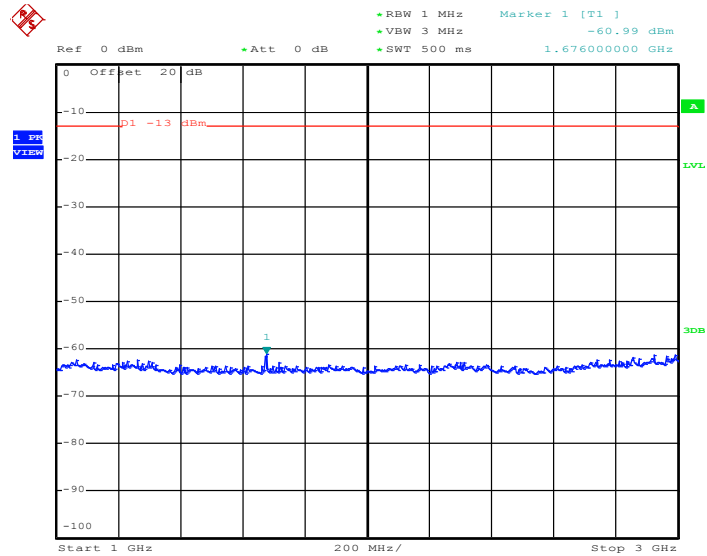

Date: 1.NOV.2013 22:19:59

Conducted Spurious Emission Plot between 3GHz ~ 7GHz

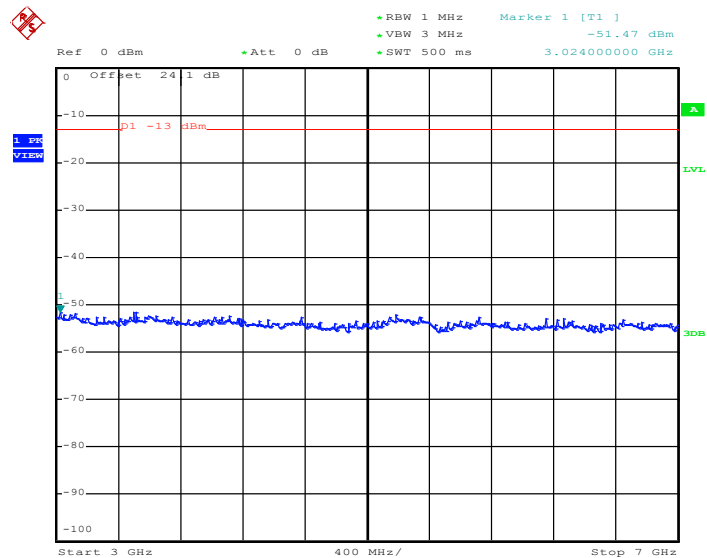

Date: 1.NOV.2013 22:20:11



Conducted Spurious Emission Plot between 7GHz ~ 9GHz

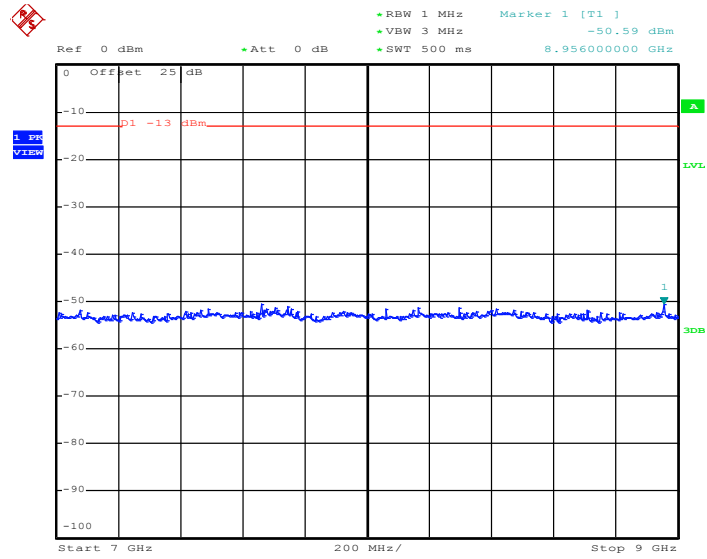

Date: 1.NOV.2013 22:20:24



Band :	WCDMA Band V	Channel :	CH4233
Test Mode :	RMC 12.2Kbps Link (QPSK)	Frequency :	846.6 MHz

Conducted Spurious Emission Plot between 30MHz ~ 1GHz

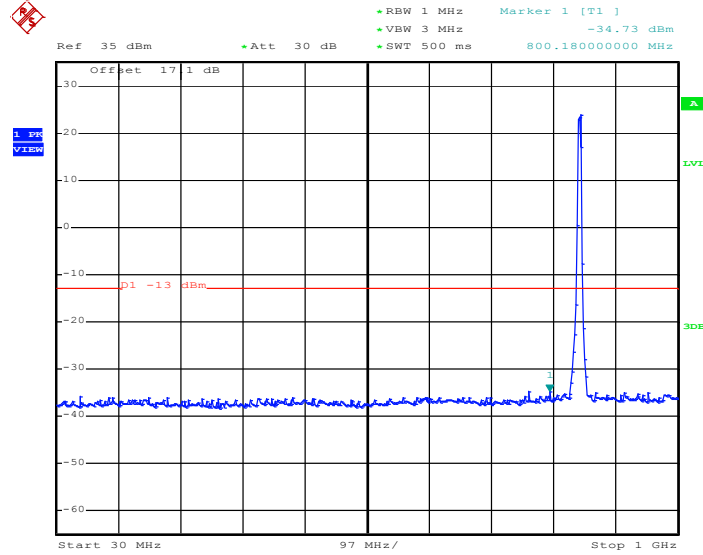

Date: 3.DEC.2013 21:42:06

Note: The RF fundamental frequency should be excluded against the limit line in the operating frequency band.



Conducted Spurious Emission Plot between 1GHz ~ 3GHz

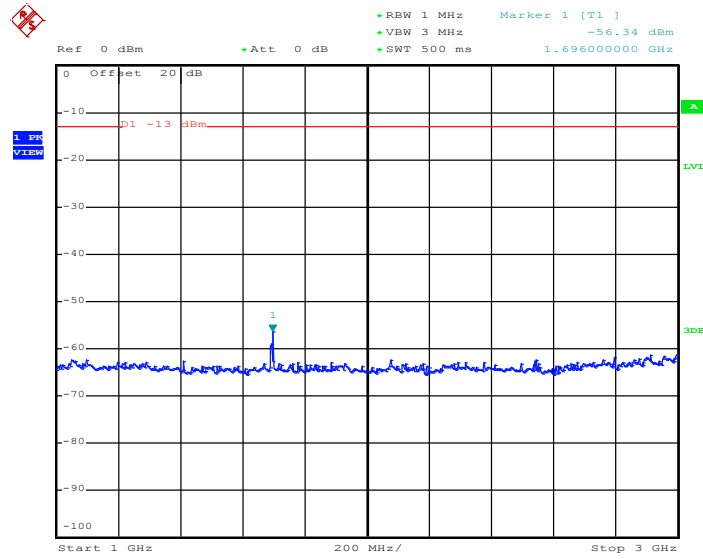

Date: 3.DEC.2013 21:42:19

Conducted Spurious Emission Plot between 3GHz ~ 7GHz

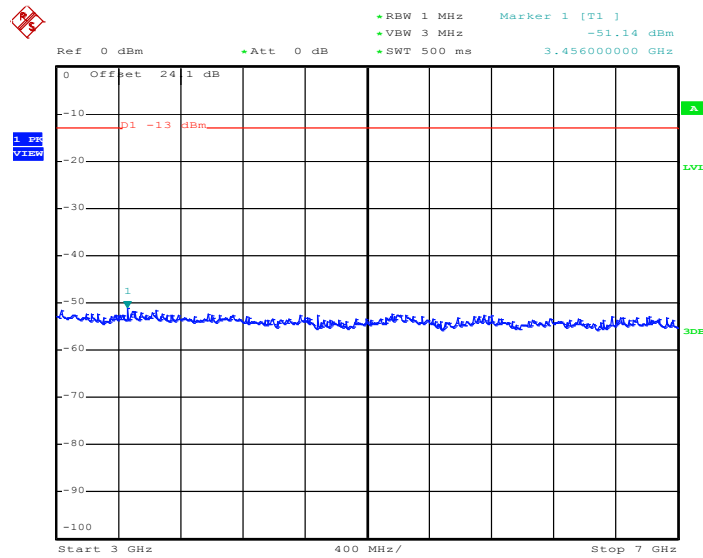

Date: 3.DEC.2013 21:42:29



Conducted Spurious Emission Plot between 7GHz ~ 9GHz

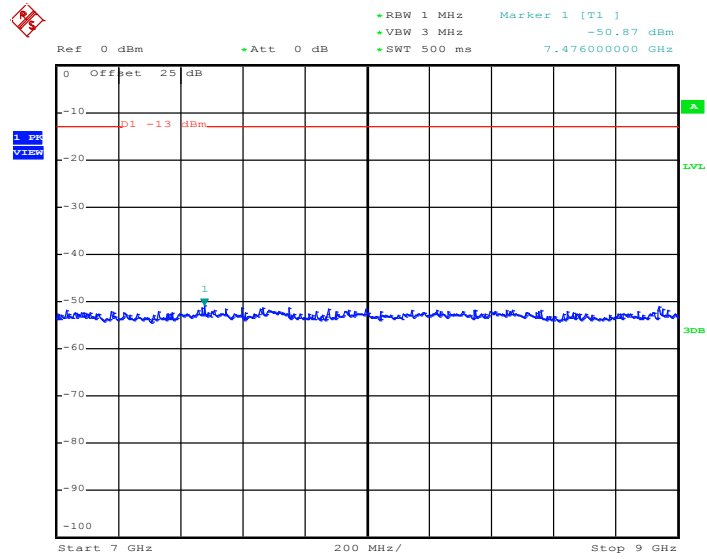

Date: 3.DEC.2013 21:42:39



Band :	WCDMA Band II	Channel :	CH9262
Test Mode :	RMC 12.2Kbps Link (QPSK)	Frequency :	1852.4 MHz

Conducted Spurious Emission Plot between 30MHz ~ 1GHz

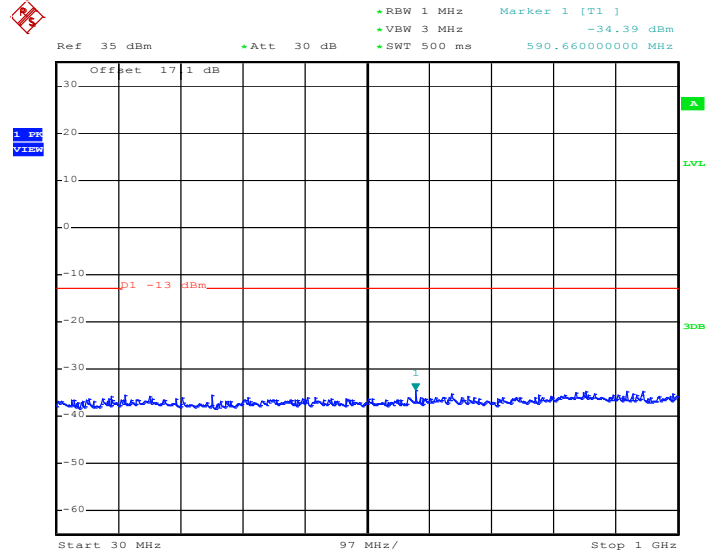

Date: 3.DEC.2013 21:33:22



Conducted Spurious Emission Plot between 1GHz ~ 3GHz

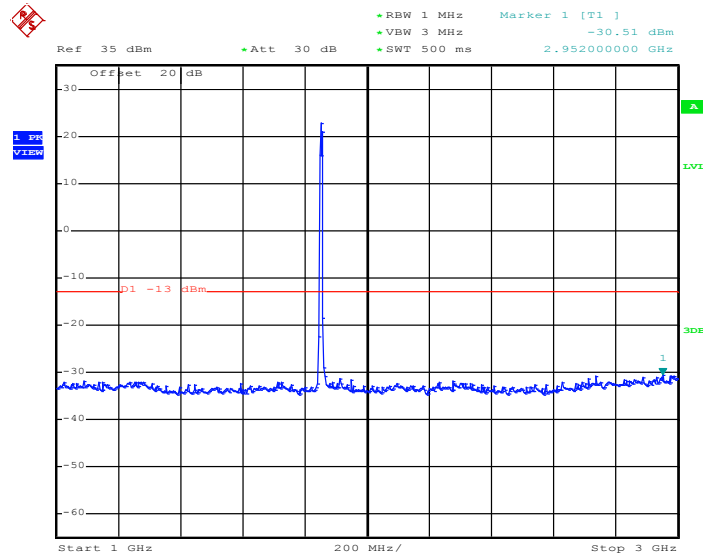

Date: 3.DEC.2013 21:33:31

Note: The RF fundamental frequency should be excluded against the limit line in the operating frequency band.

Conducted Spurious Emission Plot between 3GHz ~ 7GHz

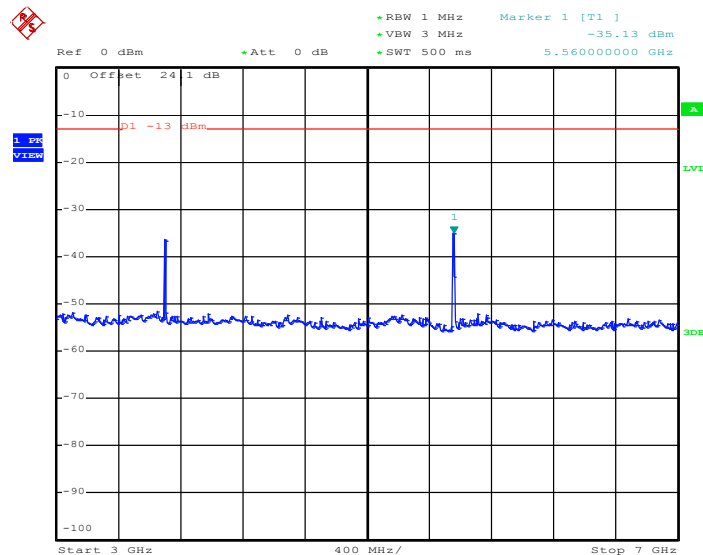

Date: 3.DEC.2013 21:33:45



Conducted Spurious Emission Plot between 7GHz ~ 13.6GHz

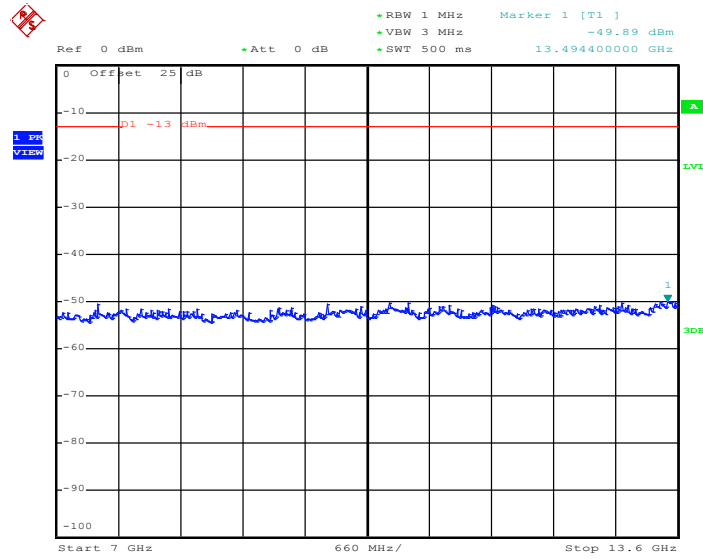

Date: 3.DEC.2013 21:33:54

Conducted Spurious Emission Plot between 13.6GHz ~ 19.1GHz

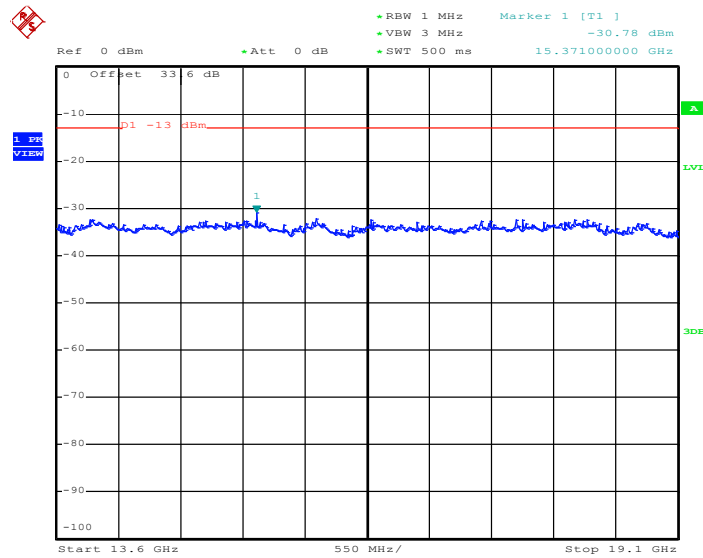

Date: 3.DEC.2013 21:34:04



Band :	WCDMA Band II	Channel :	CH9400
Test Mode :	RMC 12.2Kbps Link (QPSK)	Frequency :	1880.0 MHz

Conducted Spurious Emission Plot between 30MHz ~ 1GHz

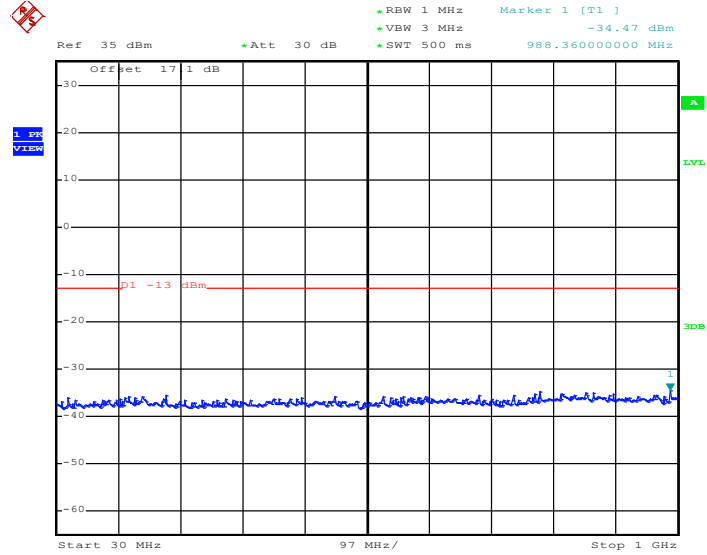

Date: 1.NOV.2013 22:11:37



Conducted Spurious Emission Plot between 1GHz ~ 3GHz

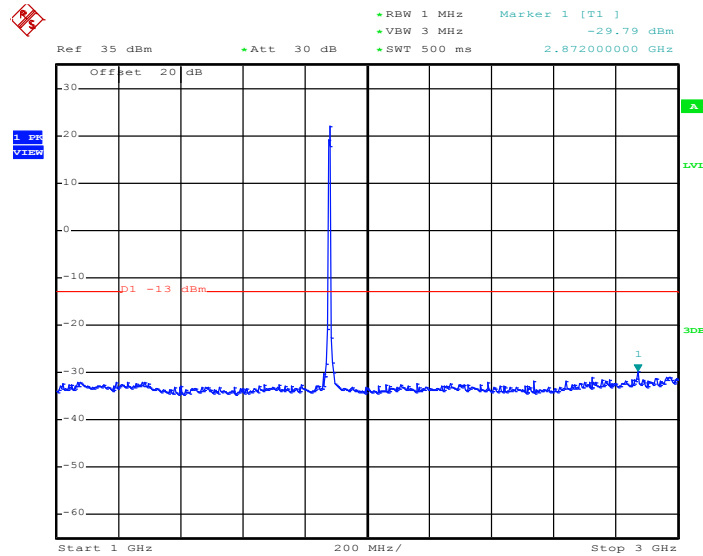

Date: 1.NOV.2013 22:11:49

Note: The RF fundamental frequency should be excluded against the limit line in the operating frequency band.

Conducted Spurious Emission Plot between 3GHz ~ 7GHz

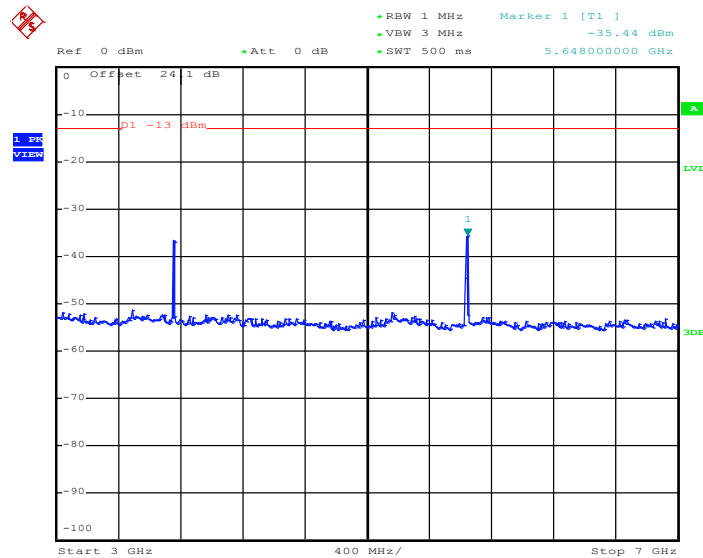

Date: 1.NOV.2013 22:12:07



Conducted Spurious Emission Plot between 7GHz ~ 13.6GHz

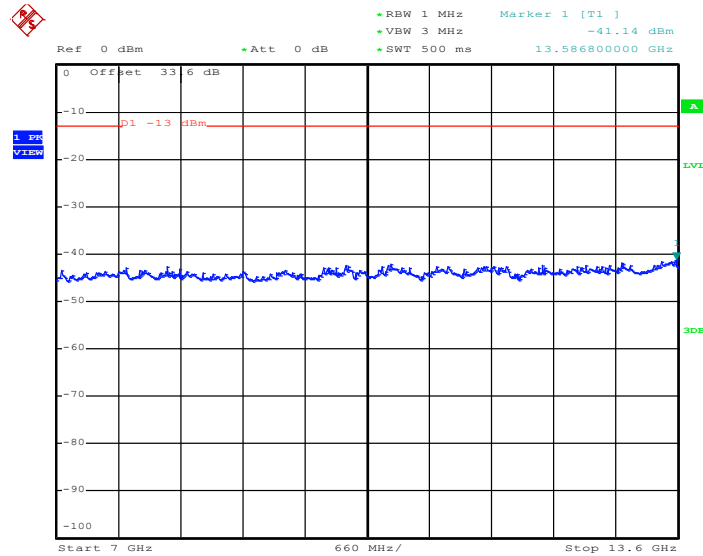

Date: 1.NOV.2013 22:12:20

Conducted Spurious Emission Plot between 13.6GHz ~ 19.1GHz

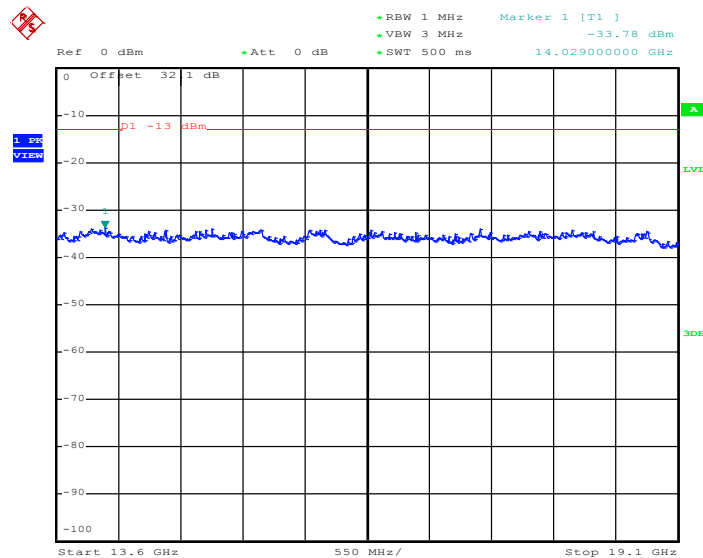

Date: 1.NOV.2013 22:12:32



Band :	WCDMA Band II	Channel :	CH9538
Test Mode :	RMC 12.2Kbps Link (QPSK)	Frequency :	1907.6 MHz

Conducted Spurious Emission Plot between 30MHz ~ 1GHz

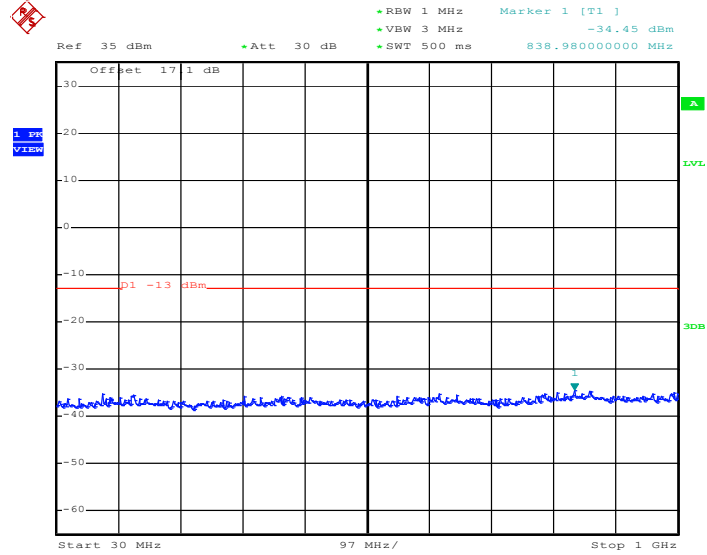

Date: 3.DEC.2013 21:36:57



Conducted Spurious Emission Plot between 1GHz ~ 3GHz

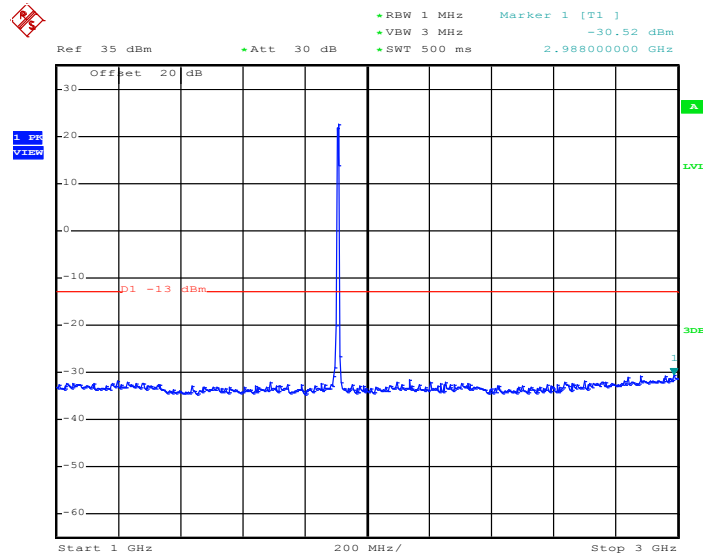

Date: 3.DEC.2013 21:37:07

Note: The RF fundamental frequency should be excluded against the limit line in the operating frequency band.

Conducted Spurious Emission Plot between 3GHz ~ 7GHz

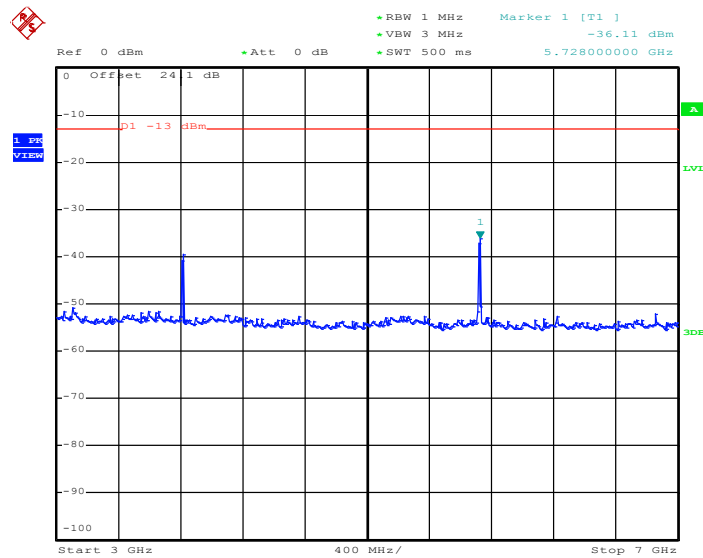

Date: 3.DEC.2013 21:37:20



Conducted Spurious Emission Plot between 7GHz ~ 13.6GHz

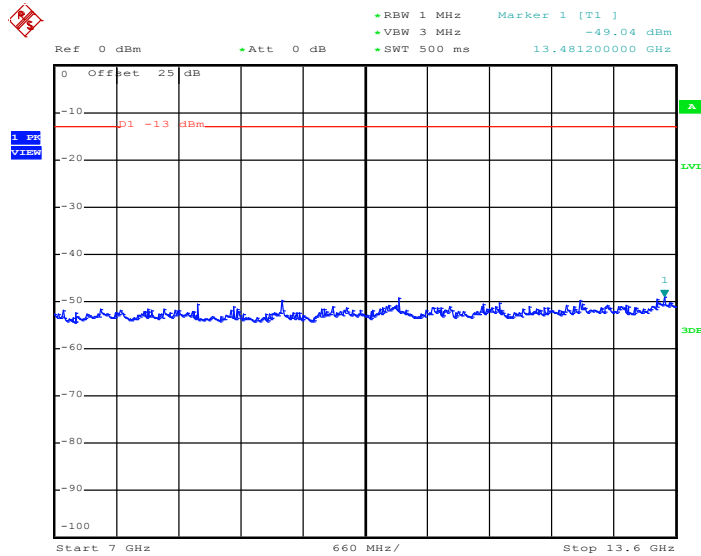

Date: 3.DEC.2013 21:37:29

Conducted Spurious Emission Plot between 13.6GHz ~ 19.1GHz

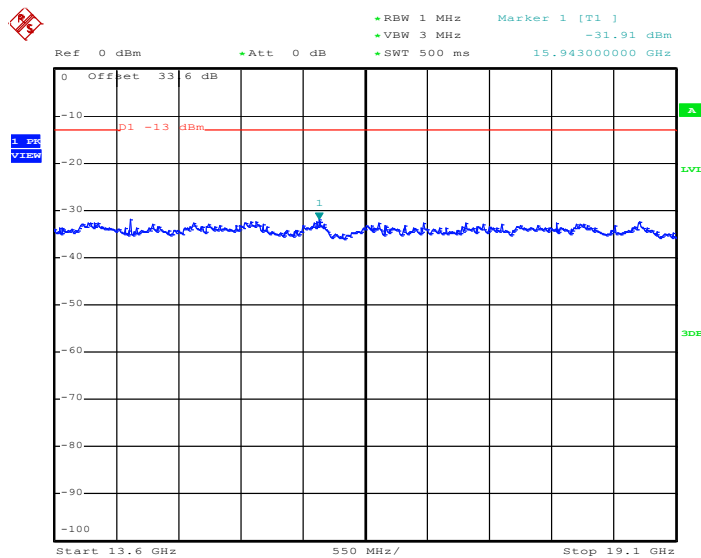

Date: 3.DEC.2013 21:37:39



3.7 Field Strength of Spurious Radiation Measurement

3.7.1 Description of Field Strength of Spurious Radiated Measurement

The power of any emission outside of the authorized operating frequency ranges must be attenuated below the transmitter power (P) by a factor of at least $43 + 10 \log (P)$ dB. The spectrum is scanned from 30 MHz up to a frequency including its 10th harmonic.

3.7.2 Measuring Instruments

The measuring equipment is listed in the section 4 of this test report.

3.7.3 Test Procedures

1. The EUT was placed on a rotatable wooden table with 0.8 meter above ground.
2. The EUT was set 3 meters from the receiving antenna, which was mounted on the antenna tower.
3. The table was rotated 360 degrees to determine the position of the highest spurious emission.
4. The height of the receiving antenna is varied between one meter and four meters to search the maximum spurious emission for both horizontal and vertical polarizations.
5. Make the measurement with the spectrum analyzer's RBW = 1MHz, VBW = 3MHz, taking the record of maximum spurious emission.
6. A horn antenna was substituted in place of the EUT and was driven by a signal generator.
7. Tune the output power of signal generator to the same emission level with EUT maximum spurious emission.
8. Taking the record of output power at antenna port.
9. Repeat step 7 to step 8 for another polarization.
10. The RF fundamental frequency should be excluded against the limit line in the operating frequency band.
11. The limit line is derived from $43 + 10\log(P)$ dB below the transmitter power P(Watts)
 $= P(W) - [43 + 10\log(P)]$ (dB)
 $= [30 + 10\log(P)]$ (dBm) - $[43 + 10\log(P)]$ (dB)
 $= -13\text{dBm}$.
12. EIRP (dBm) = S.G. Power – Tx Cable Loss + Tx Antenna Gain
13. ERP (dBm) = EIRP - 2.15

3.7.4 Test Setup

For radiated emissions from 30MHz to 1GHz

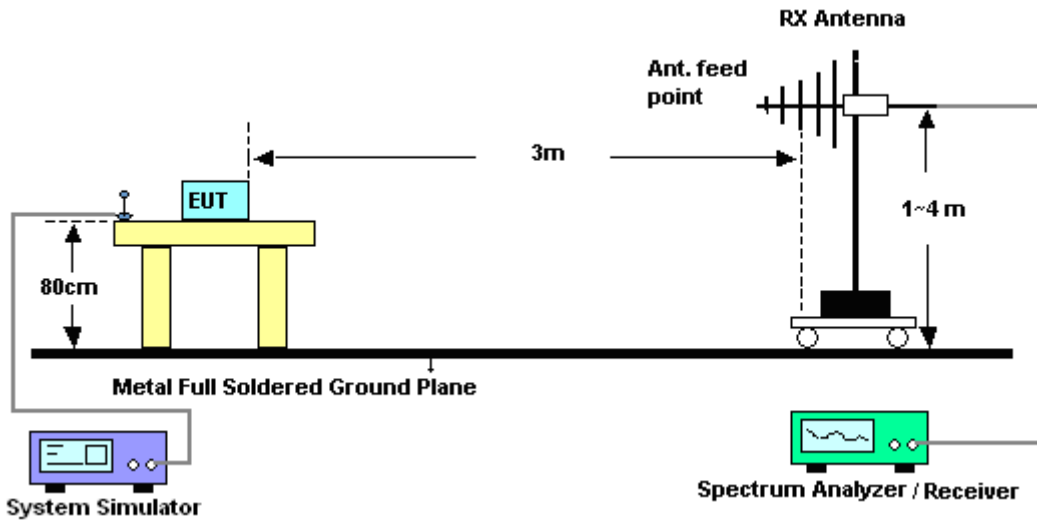

For radiated emissions above 1GHz

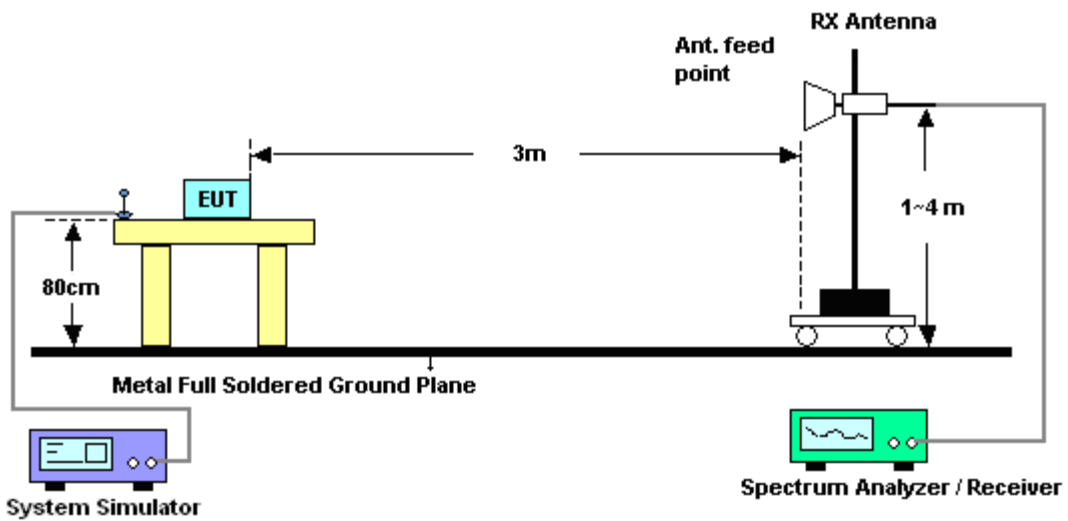



3.7.5 Test Result of Field Strength of Spurious Radiated

<Low Channel>

Band :	GSM850	Temperature :	22~24°C
Test Mode :	GSM Link (GMSK)	Relative Humidity :	45~52%
Channel :	128	Polarization :	Horizontal
Test Engineer :	Eric Shih		

Remark :

- Spurious emissions within 30-1000MHz were found more than 20dB below limit line.
- The harmonic (6th, 7th, 8th,...etc.) and other spurious are not reported, because those levels are lower than average limit line and background noise.

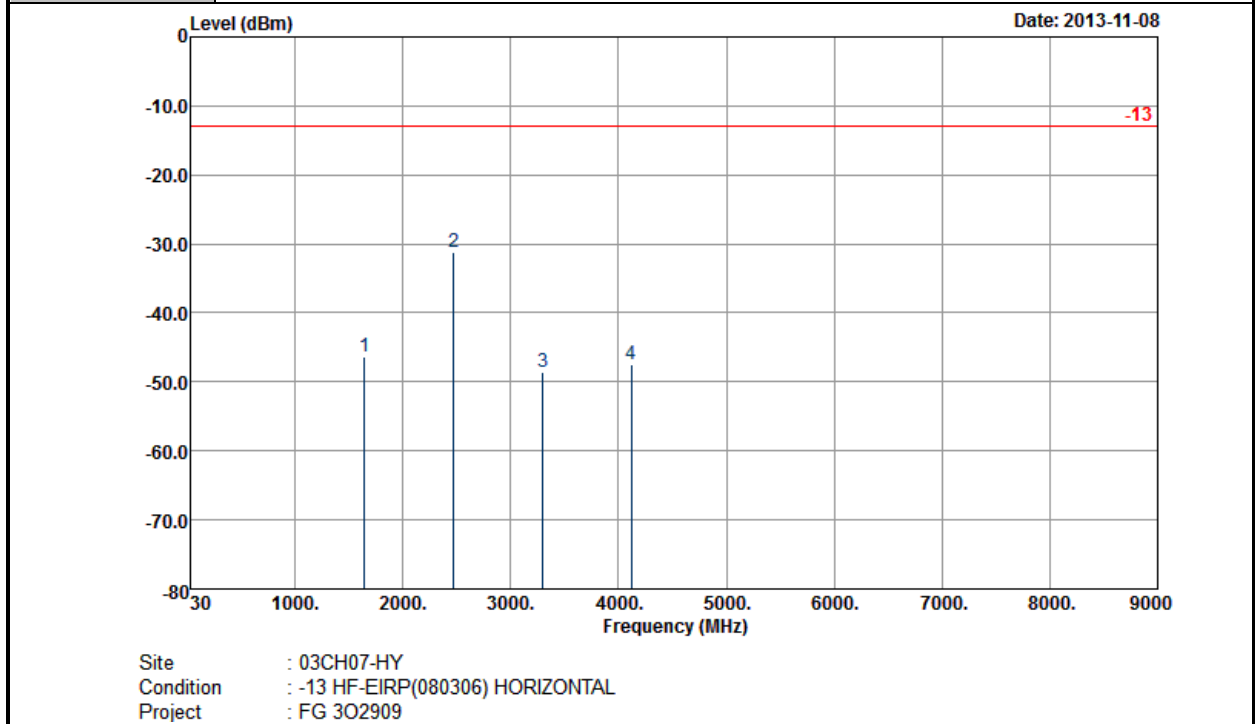

Site : 03CH07-HY
 Condition : -13 HF-EIRP(080306) HORIZONTAL
 Project : FG 3O2909

Frequency (MHz)	ERP (dBm)	Limit (dBm)	Over Limit (dB)	SPA Reading (dBm)	S.G. Power (dBm)	TX Cable loss (dB)	TX Antenna Gain (dBi)	Polarization (H/V)	Result
1648	-46.28	-13	-33.28	-55.13	-50.28	1.53	5.53	H	Pass
2473	-31.30	-13	-18.30	-44.77	-35.39	2.06	6.15	H	Pass
3298	-48.56	-13	-35.56	-62.57	-54.01	2.48	7.93	H	Pass
4120	-47.51	-13	-34.51	-63.66	-54.14	2.54	9.17	H	Pass

Other harmonics are lower than background noise



Band :	GSM850	Temperature :	22~24°C
Test Mode :	GSM Link (GMSK)	Relative Humidity :	45~52%
Channel :	128	Polarization :	Vertical
Test Engineer :	Eric Shih		
Remark :	1. Spurious emissions within 30-1000MHz were found more than 20dB below limit line. 2. The harmonic (6 th , 7 th , 8 th ,...etc.) and other spurious are not reported, because those levels are lower than average limit line and background noise.		

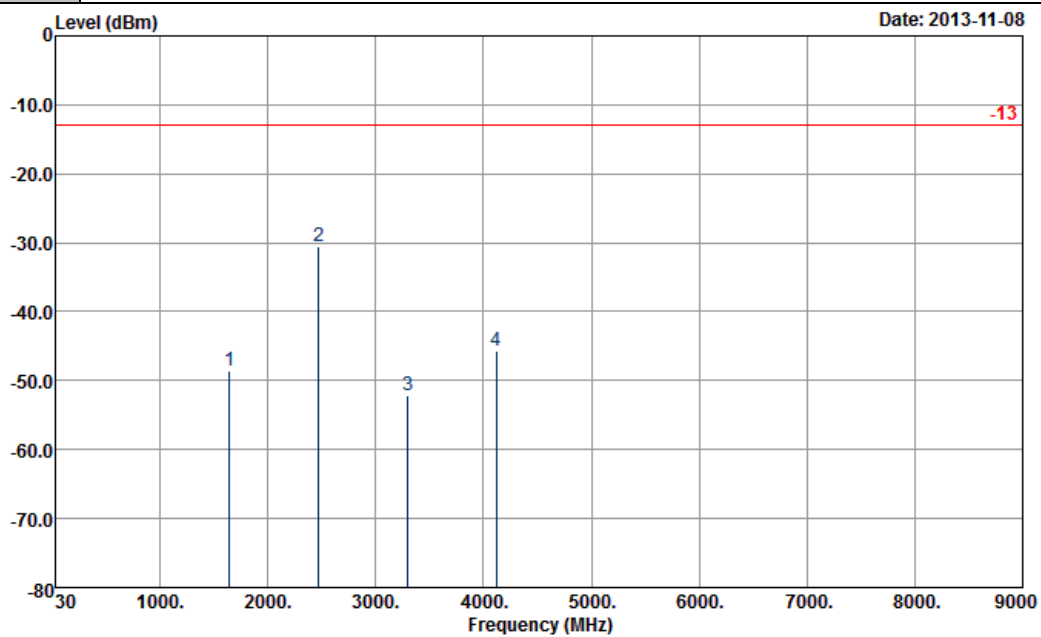

Site : 03CH07-HY
 Condition : -13 HF-EIRP(080306) VERTICAL
 Project : FG 302909

Frequency (MHz)	ERP (dBm)	Limit (dBm)	Over Limit (dB)	SPA Reading (dBm)	S.G. Power (dBm)	TX Cable loss (dB)	TX Antenna Gain (dBi)	Polarization (H/V)	Result
1648	-48.48	-13	-35.48	-59.55	-52.48	1.53	5.53	V	Pass
2473	-30.57	-13	-17.57	-44.08	-34.66	2.06	6.15	V	Pass
3296	-52.04	-13	-39.04	-67.63	-57.49	2.48	7.93	V	Pass
4120	-45.58	-13	-32.58	-62.66	-52.21	2.54	9.17	V	Pass

Other harmonics are lower than background noise



<Middle Channel>

Band :	GSM850	Temperature :	22~24°C
Test Mode :	GSM Link (GMSK)	Relative Humidity :	45~52%
Channel :	189	Polarization :	Horizontal
Test Engineer :	Eric Shih		

Remark :

- Spurious emissions within 30-1000MHz were found more than 20dB below limit line.
- The harmonic (6th, 7th, 8th,...etc.) and other spurious are not reported, because those levels are lower than average limit line and background noise.

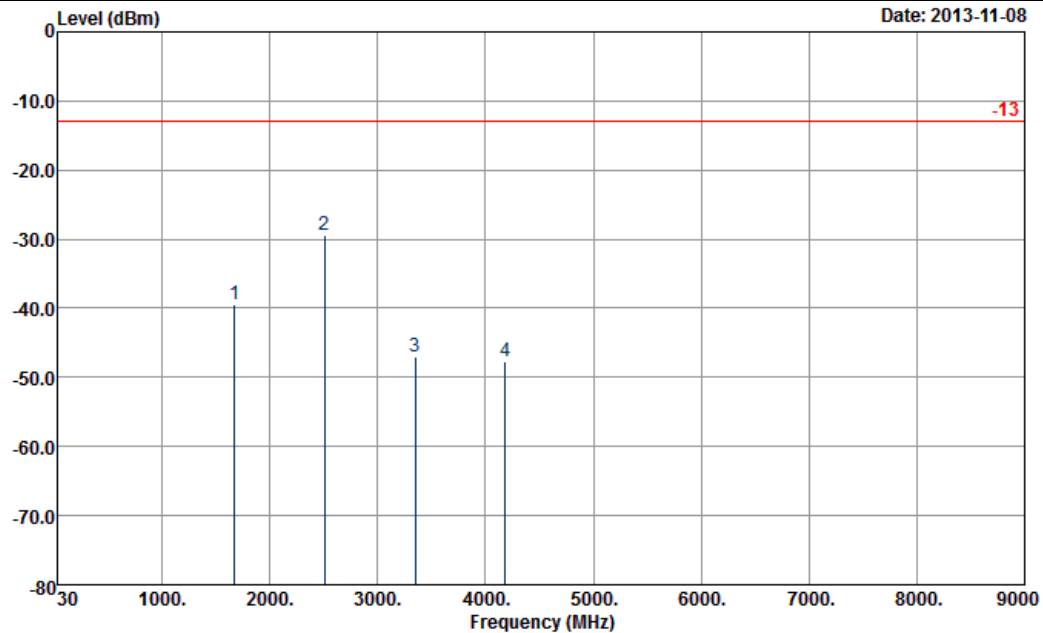

Site : 03CH07-HY
 Condition : -13 HF-EIRP(080306) HORIZONTAL
 Project : FG 3O2909

Frequency (MHz)	ERP (dBm)	Limit (dBm)	Over Limit (dB)	SPA Reading (dBm)	S.G. Power (dBm)	TX Cable loss (dB)	TX Antenna Gain (dBi)	Polarization (H/V)	Result
1672	-39.40	-13	-26.40	-48.58	-43.27	1.62	5.49	H	Pass
2509	-29.46	-13	-16.46	-42.69	-33.58	2.1	6.22	H	Pass
3346	-46.93	-13	-33.93	-61.2	-51.97	3.03	8.07	H	Pass
4180	-47.66	-13	-34.66	-64.16	-54.35	2.52	9.21	H	Pass

Other harmonics are lower than background noise



Band :	GSM850	Temperature :	22~24°C
Test Mode :	GSM Link (GMSK)	Relative Humidity :	45~52%
Channel :	189	Polarization :	Vertical
Test Engineer :	Eric Shih		
Remark :	1. Spurious emissions within 30-1000MHz were found more than 20dB below limit line. 2. The harmonic (6 th , 7 th , 8 th ,...etc.) and other spurious are not reported, because those levels are lower than average limit line and background noise.		

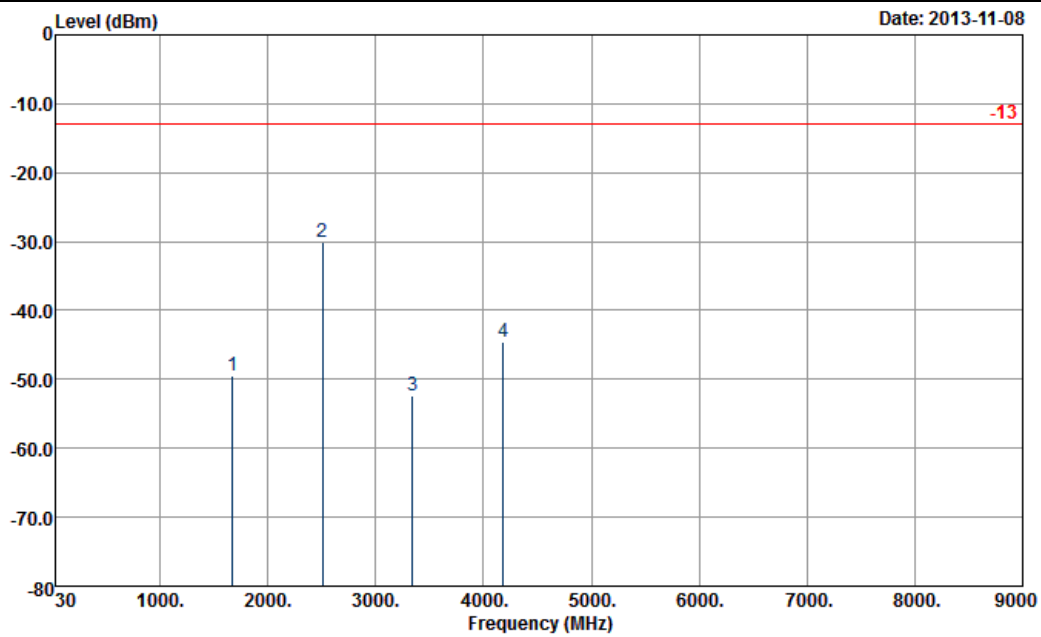

Site : 03CH07-HY
 Condition : -13 HF-EIRP(080306) VERTICAL
 Project : FG 302909

Frequency (MHz)	ERP (dBm)	Limit (dBm)	Over Limit (dB)	SPA Reading (dBm)	S.G. Power (dBm)	TX Cable loss (dB)	TX Antenna Gain (dBi)	Polarization (H/V)	Result
1672	-49.58	-13	-36.58	-60.83	-53.45	1.62	5.49	V	Pass
2509	-30.11	-13	-17.11	-43.84	-34.23	2.1	6.22	V	Pass
3345	-52.29	-13	-39.29	-67.99	-57.33	3.03	8.07	V	Pass
4180	-44.48	-13	-31.48	-61.77	-51.17	2.52	9.21	V	Pass

Other harmonics are lower than background noise



<High Channel>

Band :	GSM850	Temperature :	22~24°C
Test Mode :	GSM Link (GMSK)	Relative Humidity :	45~52%
Channel :	251	Polarization :	Horizontal
Test Engineer :	Eric Shih		

Remark :

- Spurious emissions within 30-1000MHz were found more than 20dB below limit line.
- The harmonic (6th, 7th, 8th,...etc.) and other spurious are not reported, because those levels are lower than average limit line and background noise.

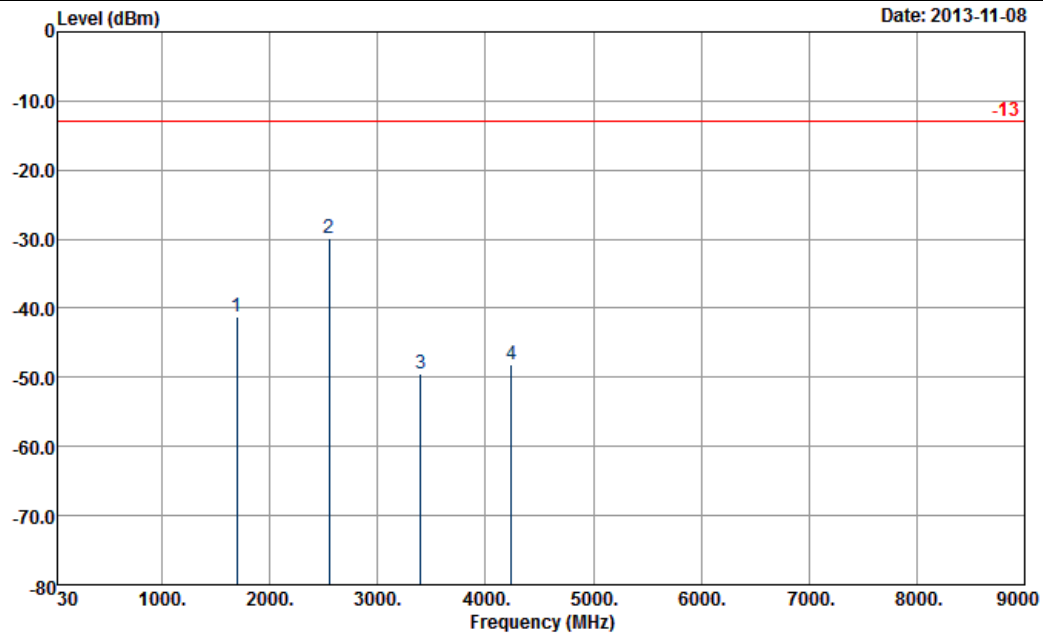

Site : 03CH07-HY
 Condition : -13 HF-EIRP(080306) HORIZONTAL
 Project : FG 3O2909

Frequency (MHz)	ERP (dBm)	Limit (dBm)	Over Limit (dB)	SPA Reading (dBm)	S.G. Power (dBm)	TX Cable loss (dB)	TX Antenna Gain (dBi)	Polarization (H/V)	Result
1696	-41.24	-13	-28.24	-50.42	-45.12	1.57	5.45	H	Pass
2548	-29.85	-13	-16.85	-42.83	-34.11	2.02	6.28	H	Pass
3397	-49.57	-13	-36.57	-63.59	-55.47	2.3	8.20	H	Pass
4240	-48.08	-13	-35.08	-63.34	-54.59	2.73	9.24	H	Pass

Other harmonics are lower than background noise



Band :	GSM850	Temperature :	22~24°C
Test Mode :	GSM Link (GMSK)	Relative Humidity :	45~52%
Channel :	251	Polarization :	Vertical
Test Engineer :	Eric Shih		

Remark :

- Spurious emissions within 30-1000MHz were found more than 20dB below limit line.
- The harmonic (6th, 7th, 8th,...etc.) and other spurious are not reported, because those levels are lower than average limit line and background noise.

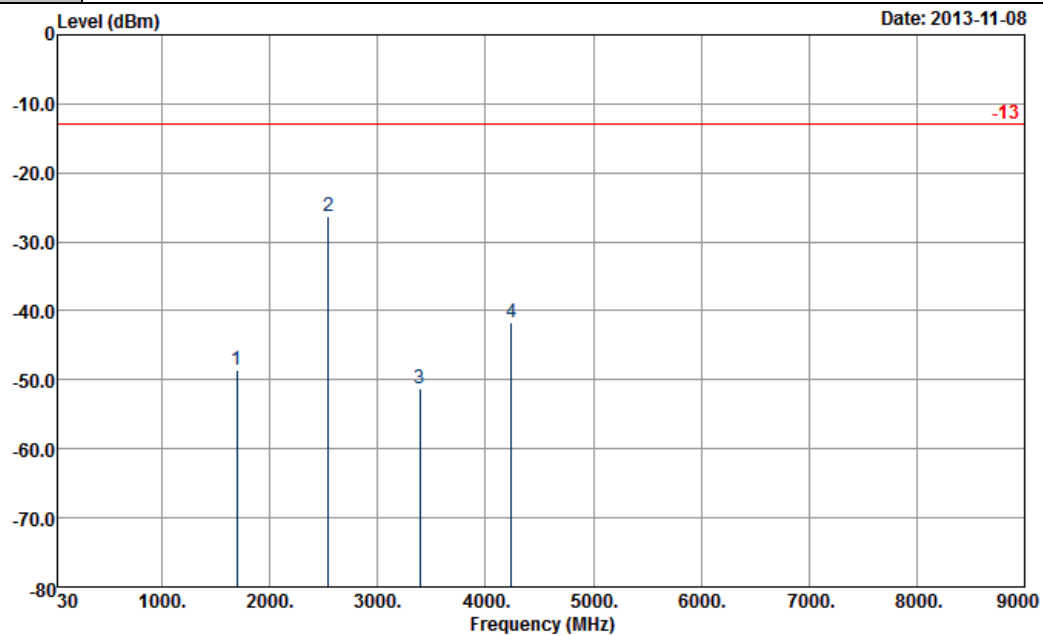

Site : 03CH07-HY
 Condition : -13 HF-EIRP(080306) VERTICAL
 Project : FG 302909

Frequency (MHz)	ERP (dBm)	Limit (dBm)	Over Limit (dB)	SPA Reading (dBm)	S.G. Power (dBm)	TX Cable loss (dB)	TX Antenna Gain (dBi)	Polarization (H/V)	Result
1696	-48.48	-13	-35.48	-59.84	-52.36	1.57	5.45	V	Pass
2545	-26.23	-13	-13.23	-40.15	-30.49	2.02	6.28	V	Pass
3392	-51.31	-13	-38.31	-66.93	-57.21	2.3	8.20	V	Pass
4240	-41.71	-13	-28.71	-58.79	-48.22	2.73	9.24	V	Pass

Other harmonics are lower than background noise



<Low Channel>

Band :	GSM850	Temperature :	22~24°C
Test Mode :	EDGE class 8 Link (8PSK)	Relative Humidity :	45~52%
Channel :	128	Polarization :	Horizontal
Test Engineer :	Eric Shih		

Remark :

- Spurious emissions within 30-1000MHz were found more than 20dB below limit line.
- The harmonic (5th, 6th, 7th,...etc.) and other spurious are not reported, because those levels are lower than average limit line and background noise.

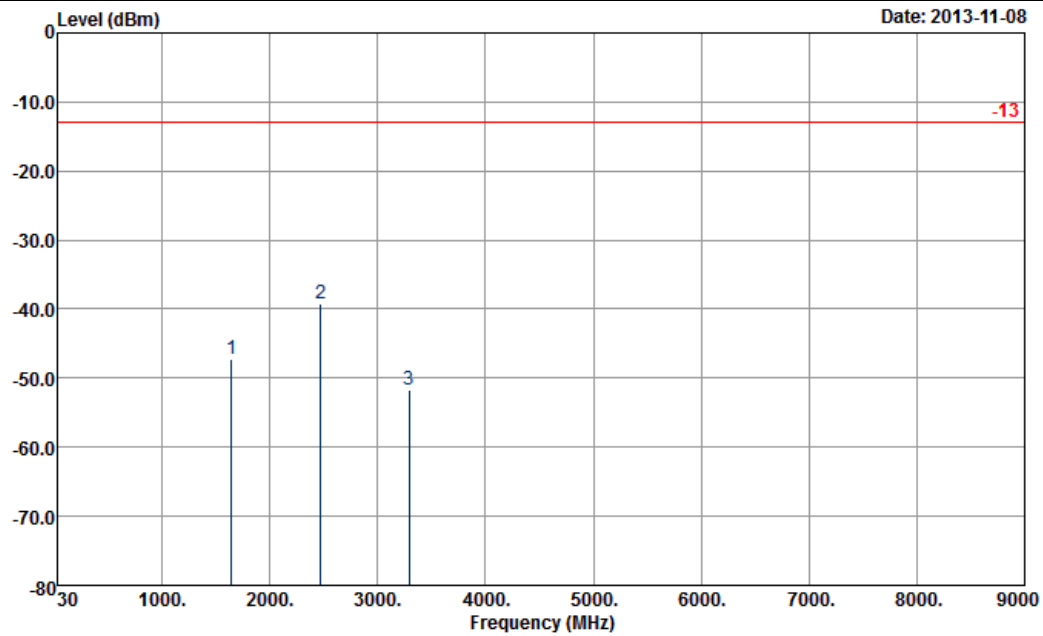

Site : 03CH07-HY
 Condition : -13 HF-EIRP(080306) HORIZONTAL
 Project : FG 302909

Frequency (MHz)	ERP (dBm)	Limit (dBm)	Over Limit (dB)	SPA Reading (dBm)	S.G. Power (dBm)	TX Cable loss (dB)	TX Antenna Gain (dBi)	Polarization (H/V)	Result
1648	-47.35	-13	-34.35	-56.16	-51.35	1.53	5.53	H	Pass
2473	-39.27	-13	-26.27	-52.79	-43.36	2.06	6.15	H	Pass
3295	-51.65	-13	-38.65	-65.7	-57.1	2.48	7.93	H	Pass

Other harmonics are lower than background noise



Band :	GSM850	Temperature :	22~24°C
Test Mode :	EDGE class 8 Link (8PSK)	Relative Humidity :	45~52%
Channel :	128	Polarization :	Vertical
Test Engineer :	Eric Shih		

Remark :

- Spurious emissions within 30-1000MHz were found more than 20dB below limit line.
- The harmonic (5th, 6th, 7th,...etc.) and other spurious are not reported, because those levels are lower than average limit line and background noise.

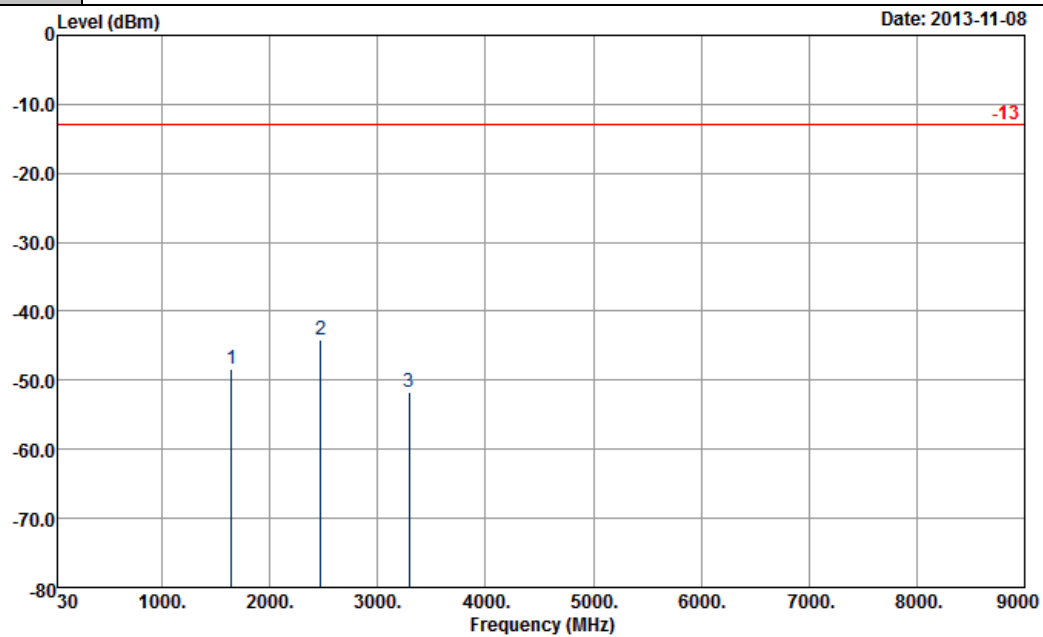

Site : 03CH07-HY
 Condition : -13 HF-EIRP(080306) VERTICAL
 Project : FG 3O2909

Frequency (MHz)	ERP (dBm)	Limit (dBm)	Over Limit (dB)	SPA Reading (dBm)	S.G. Power (dBm)	TX Cable loss (dB)	TX Antenna Gain (dBi)	Polarization (H/V)	Result
1648	-48.39	-13	-35.39	-59.68	-52.39	1.53	5.53	V	Pass
2473	-44.08	-13	-31.08	-57.83	-48.17	2.06	6.15	V	Pass
3295	-51.68	-13	-38.68	-67.42	-57.13	2.48	7.93	V	Pass

Other harmonics are lower than background noise



<Middle Channel>

Band :	GSM850	Temperature :	22~24°C
Test Mode :	EDGE class 8 Link (8PSK)	Relative Humidity :	45~52%
Channel :	189	Polarization :	Horizontal
Test Engineer :	Eric Shih		

Remark :

- Spurious emissions within 30-1000MHz were found more than 20dB below limit line.
- The harmonic (5th, 6th, 7th,...etc.) and other spurious are not reported, because those levels are lower than average limit line and background noise.

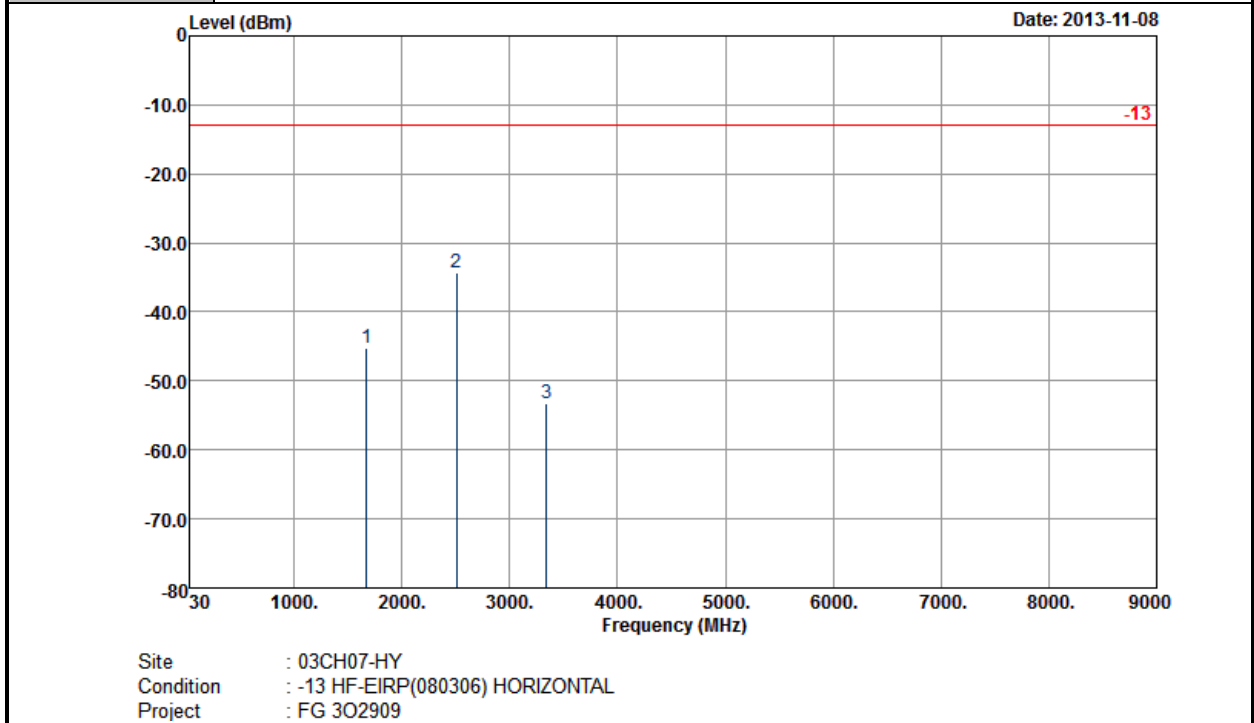

Site : 03CH07-HY
 Condition : -13 HF-EIRP(080306) HORIZONTAL
 Project : FG 3O2909

Frequency (MHz)	ERP (dBm)	Limit (dBm)	Over Limit (dB)	SPA Reading (dBm)	S.G. Power (dBm)	TX Cable loss (dB)	TX Antenna Gain (dBi)	Polarization (H/V)	Result
1672	-45.14	-13	-32.14	-54.08	-49.01	1.62	5.49	H	Pass
2509	-34.36	-13	-21.36	-47.72	-38.48	2.1	6.22	H	Pass
3344	-53.35	-13	-40.35	-67.67	-58.39	3.03	8.07	H	Pass

Other harmonics are lower than background noise



Band :	GSM850	Temperature :	22~24°C
Test Mode :	EDGE class 8 Link (8PSK)	Relative Humidity :	45~52%
Channel :	189	Polarization :	Vertical
Test Engineer :	Eric Shih		

Remark :

- Spurious emissions within 30-1000MHz were found more than 20dB below limit line.
- The harmonic (5th, 6th, 7th,...etc.) and other spurious are not reported, because those levels are lower than average limit line and background noise.

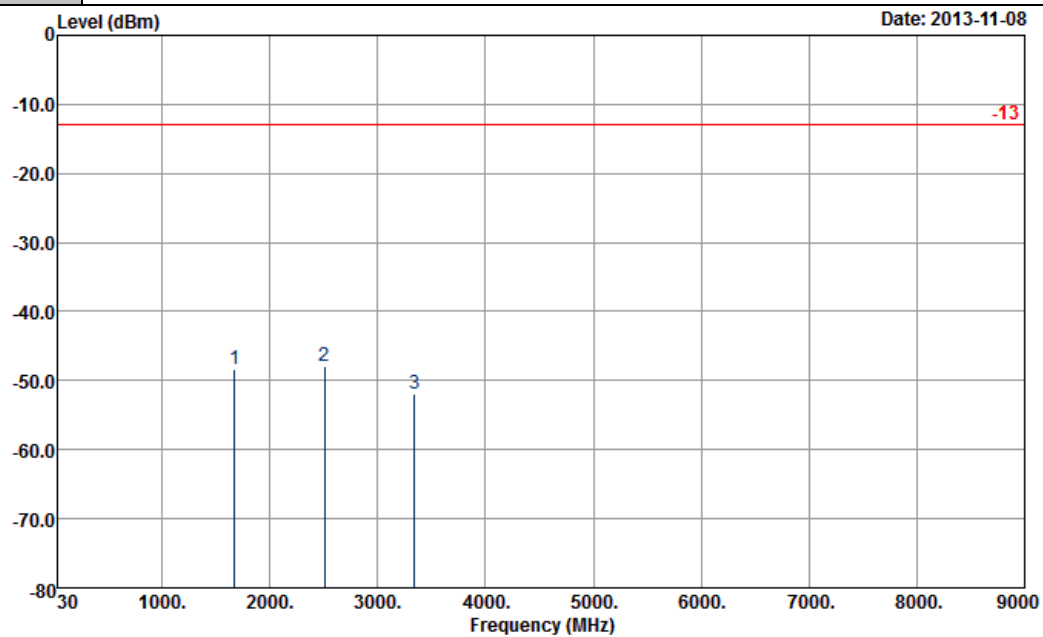

Site : 03CH07-HY
 Condition : -13 HF-EIRP(080306) VERTICAL
 Project : FG 302909

Frequency (MHz)	ERP (dBm)	Limit (dBm)	Over Limit (dB)	SPA Reading (dBm)	S.G. Power (dBm)	TX Cable loss (dB)	TX Antenna Gain (dBi)	Polarization (H/V)	Result
1672	-48.25	-13	-35.25	-59.4	-52.12	1.62	5.49	V	Pass
2509	-47.98	-13	-34.98	-61.76	-52.1	2.1	6.22	V	Pass
3344	-51.96	-13	-38.96	-67.95	-57	3.03	8.07	V	Pass

Other harmonics are lower than background noise



<High Channel>

Band :	GSM850	Temperature :	22~24°C
Test Mode :	EDGE class 8 Link (8PSK)	Relative Humidity :	45~52%
Channel :	251	Polarization :	Horizontal
Test Engineer :	Eric Shih		

Remark :

- Spurious emissions within 30-1000MHz were found more than 20dB below limit line.
- The harmonic (5th, 6th, 7th,...etc.) and other spurious are not reported, because those levels are lower than average limit line and background noise.

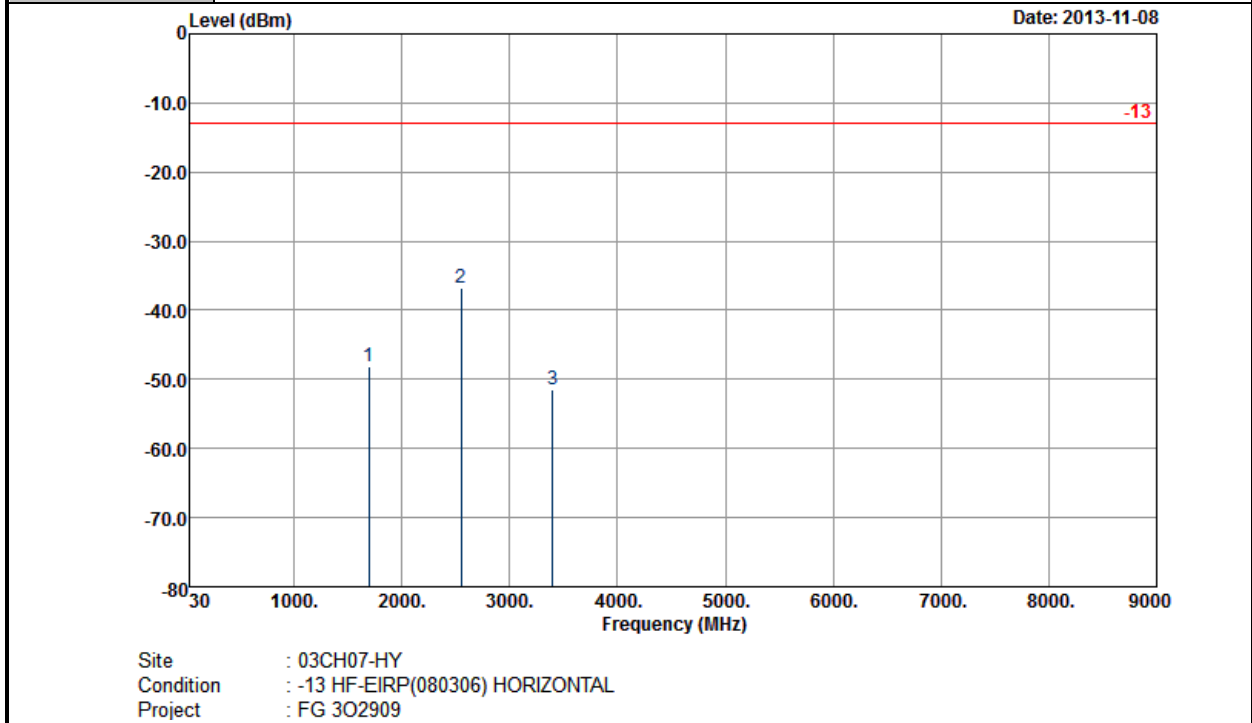

Site : 03CH07-HY
 Condition : -13 HF-EIRP(080306) HORIZONTAL
 Project : FG 302909

Frequency (MHz)	ERP (dBm)	Limit (dBm)	Over Limit (dB)	SPA Reading (dBm)	S.G. Power (dBm)	TX Cable loss (dB)	TX Antenna Gain (dBi)	Polarization (H/V)	Result
1696	-48.13	-13	-35.13	-57.18	-52.01	1.57	5.45	H	Pass
2548	-36.85	-13	-23.85	-50.09	-41.11	2.02	6.28	H	Pass
3397	-51.58	-13	-38.58	-65.75	-57.48	2.3	8.20	H	Pass

Other harmonics are lower than background noise



Band :	GSM850	Temperature :	22~24°C
Test Mode :	EDGE class 8 Link (8PSK)	Relative Humidity :	45~52%
Channel :	251	Polarization :	Vertical
Test Engineer :	Eric Shih		

Remark :

- Spurious emissions within 30-1000MHz were found more than 20dB below limit line.
- The harmonic (5th, 6th, 7th,...etc.) and other spurious are not reported, because those levels are lower than average limit line and background noise.

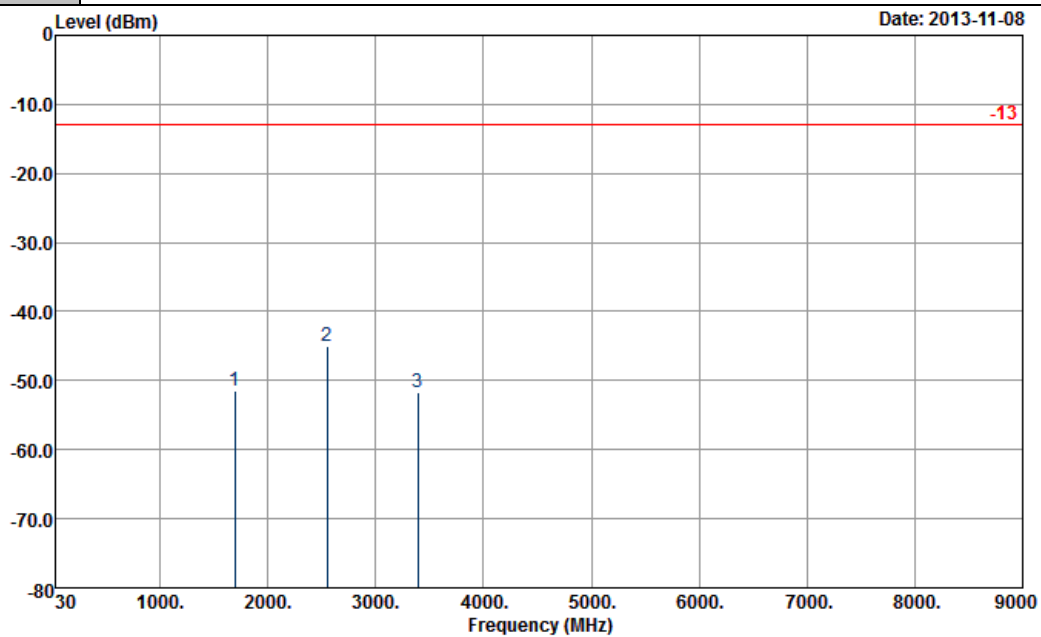

Site : 03CH07-HY
 Condition : -13 HF-EIRP(080306) VERTICAL
 Project : FG 3O2909

Frequency (MHz)	ERP (dBm)	Limit (dBm)	Over Limit (dB)	SPA Reading (dBm)	S.G. Power (dBm)	TX Cable loss (dB)	TX Antenna Gain (dBi)	Polarization (H/V)	Result
1696	-51.47	-13	-38.47	-63.01	-55.35	1.57	5.45	V	Pass
2548	-45.12	-13	-32.12	-59.09	-49.38	2.02	6.28	V	Pass
3392	-51.65	-13	-38.65	-67.35	-57.55	2.3	8.20	V	Pass

Other harmonics are lower than background noise



<Low Channel>

Band :	GSM1900	Temperature :	22~24°C
Test Mode :	GPRS class 8 Link (GMSK)	Relative Humidity :	45~52%
Channel :	512	Polarization :	Horizontal
Test Engineer :	Eric Shih		

Remark :

- Spurious emissions within 30-1000MHz were found more than 20dB below limit line.
- The harmonic (5th, 6th, 7th,...etc.) and other spurious are not reported, because those levels are lower than average limit line and background noise.

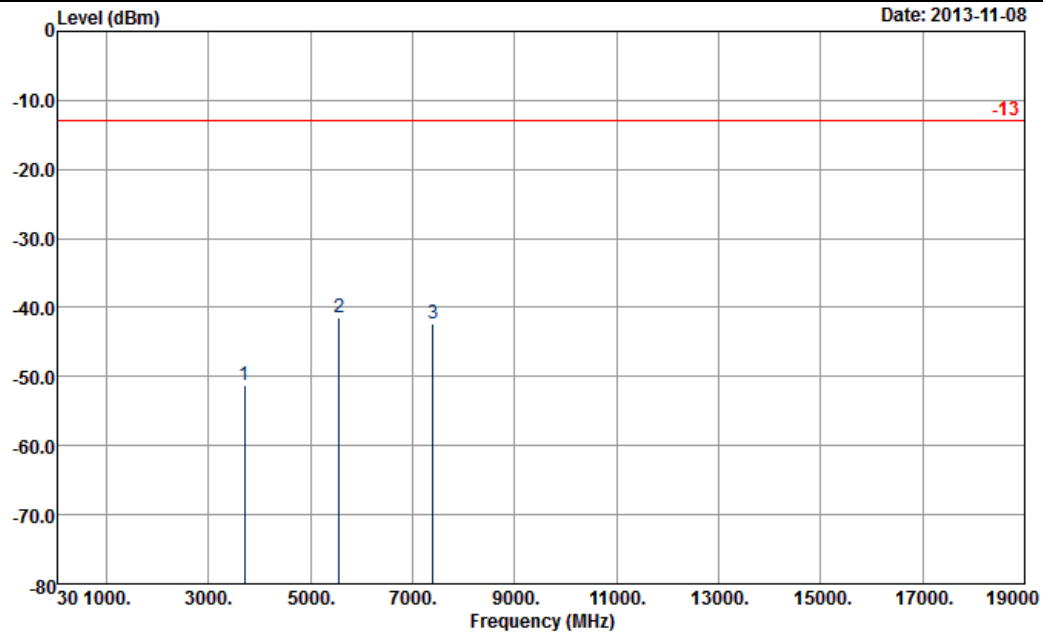

Site : 03CH07-HY
 Condition : -13 HF-EIRP(080306) HORIZONTAL
 Project : FG 3O2909

Frequency (MHz)	EIRP (dBm)	Limit (dBm)	Over Limit (dB)	SPA Reading (dBm)	S.G. Power (dBm)	TX Cable loss (dB)	TX Antenna Gain (dBi)	Polarization (H/V)	Result
3700	-51.34	-13	-38.34	-66.71	-57.49	2.59	8.74	H	Pass
5552	-41.46	-13	-28.46	-61.87	-49.12	3.04	10.70	H	Pass
7400	-42.27	-13	-29.27	-69.64	-51.01	3.28	12.02	H	Pass

Other harmonics are lower than background noise



Band :	GSM1900	Temperature :	22~24°C
Test Mode :	GPRS class 8 Link (GMSK)	Relative Humidity :	45~52%
Channel :	512	Polarization :	Vertical
Test Engineer :	Eric Shih		

Remark :

- Spurious emissions within 30-1000MHz were found more than 20dB below limit line.
- The harmonic (5th, 6th, 7th,...etc.) and other spurious are not reported, because those levels are lower than average limit line and background noise.

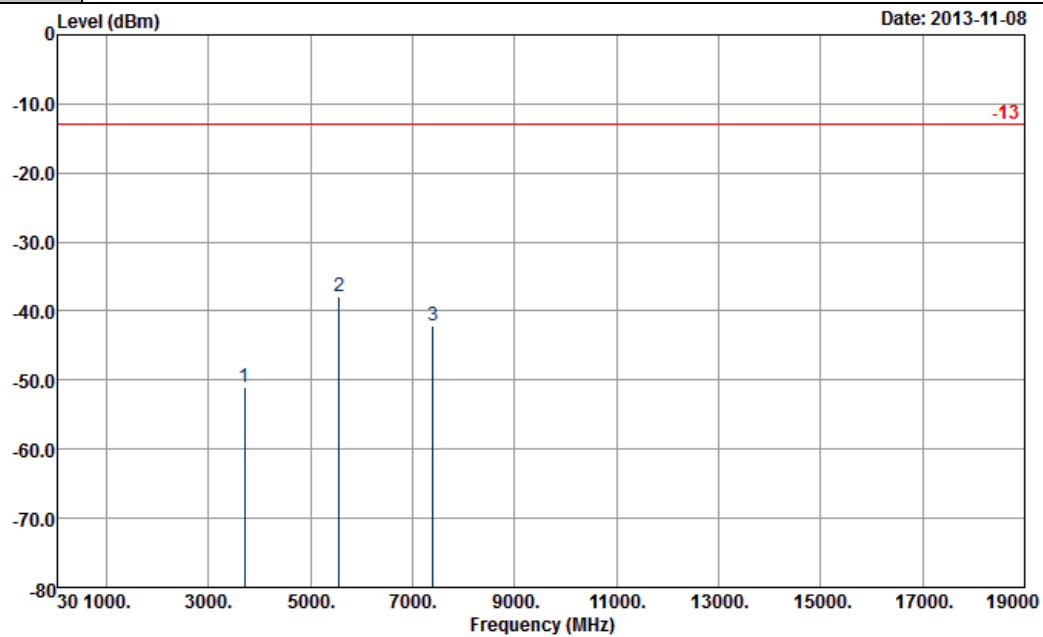

Site : 03CH07-HY
 Condition : -13 HF-EIRP(080306) VERTICAL
 Project : FG 302909

Frequency (MHz)	EIRP (dBm)	Limit (dBm)	Over Limit (dB)	SPA Reading (dBm)	S.G. Power (dBm)	TX Cable loss (dB)	TX Antenna Gain (dBi)	Polarization (H/V)	Result
3700	-51.14	-13	-38.14	-67.2	-57.29	2.59	8.74	V	Pass
5552	-37.83	-13	-24.83	-58.11	-45.49	3.04	10.70	V	Pass
7400	-42.15	-13	-29.15	-69.16	-50.89	3.28	12.02	V	Pass

Other harmonics are lower than background noise



<Middle Channel>

Band :	GSM1900	Temperature :	22~24°C
Test Mode :	GPRS class 8 Link (GMSK)	Relative Humidity :	45~52%
Channel :	661	Polarization :	Horizontal
Test Engineer :	Eric Shih		

Remark :

- Spurious emissions within 30-1000MHz were found more than 20dB below limit line.
- The harmonic (5th, 7th, 8th,...etc.) and other spurious are not reported, because those levels are lower than average limit line and background noise.

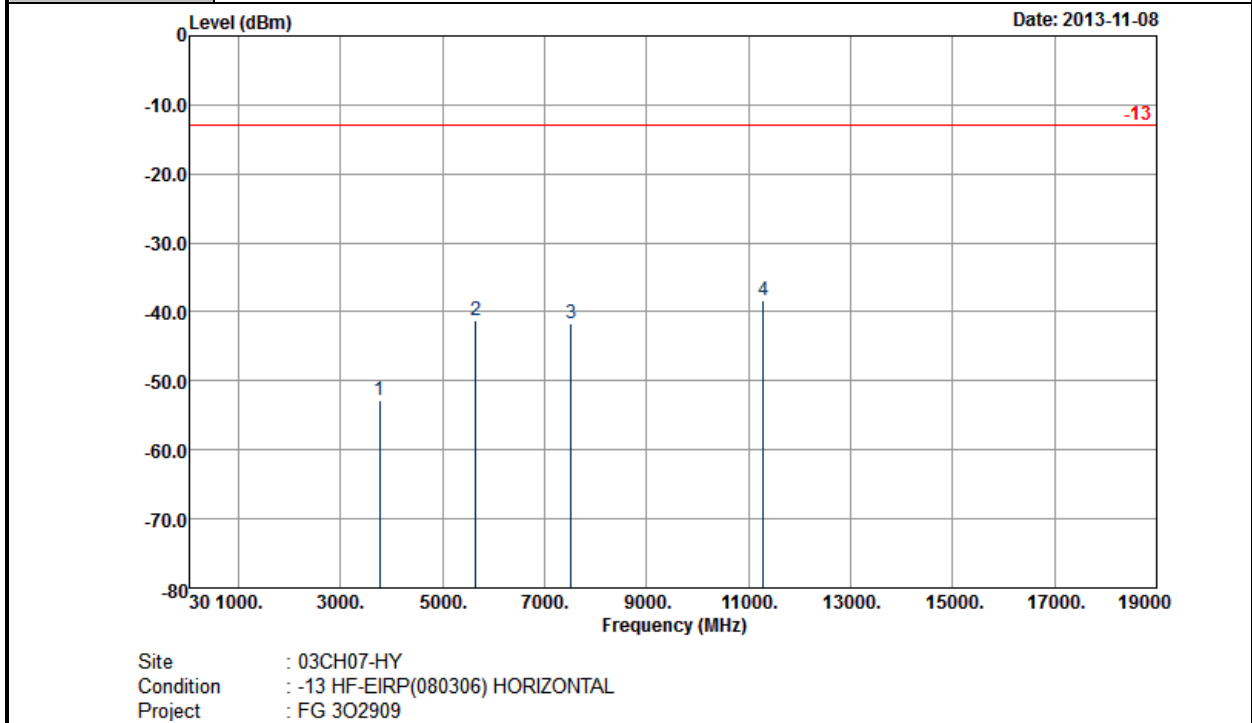

Site : 03CH07-HY
 Condition : -13 HF-EIRP(080306) HORIZONTAL
 Project : FG 302909

Frequency (MHz)	EIRP (dBm)	Limit (dBm)	Over Limit (dB)	SPA Reading (dBm)	S.G. Power (dBm)	TX Cable loss (dB)	TX Antenna Gain (dBi)	Polarization (H/V)	Result
3760	-52.81	-13	-39.81	-67.95	-59.11	2.51	8.81	H	Pass
5640	-41.31	-13	-28.31	-62.03	-49.02	2.99	10.70	H	Pass
7520	-41.70	-13	-28.70	-68.9	-50.23	3.59	12.12	H	Pass
11280	-38.41	-13	-25.41	-67.96	-47.45	4.27	13.31	H	Pass

Other harmonics are lower than background noise



Band :	GSM1900	Temperature :	22~24°C
Test Mode :	GPRS class 8 Link (GMSK)	Relative Humidity :	45~52%
Channel :	661	Polarization :	Vertical
Test Engineer :	Eric Shih		

Remark :

- Spurious emissions within 30-1000MHz were found more than 20dB below limit line.
- The harmonic (5th, 7th, 8th,...etc.) and other spurious are not reported, because those levels are lower than average limit line and background noise.

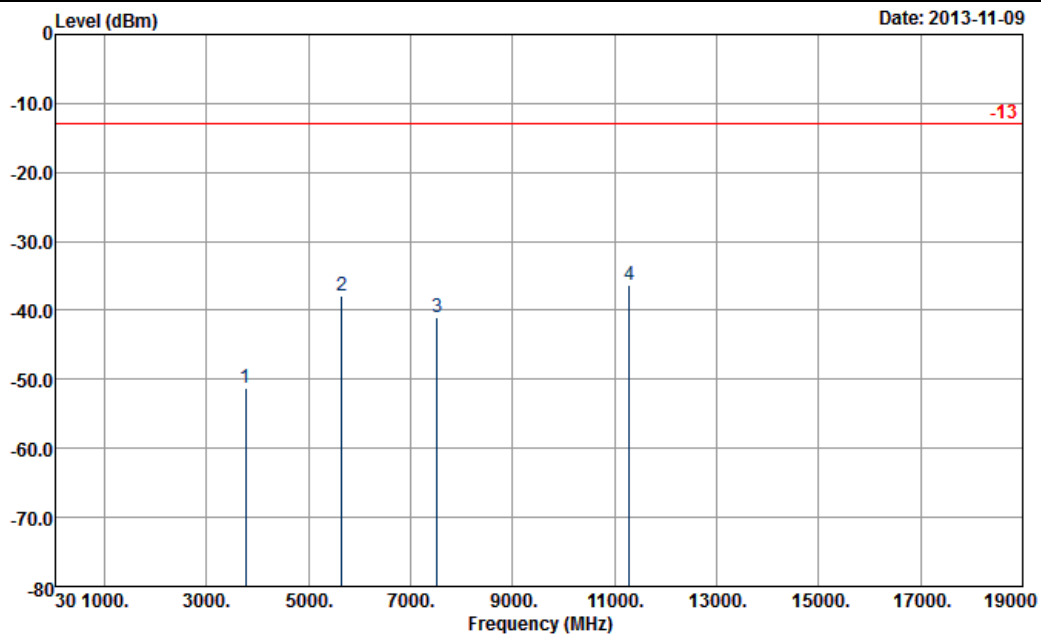

Site : 03CH07-HY
 Condition : -13 HF-EIRP(080306) VERTICAL
 Project : FG 3O2909

Frequency (MHz)	EIRP (dBm)	Limit (dBm)	Over Limit (dB)	SPA Reading (dBm)	S.G. Power (dBm)	TX Cable loss (dB)	TX Antenna Gain (dBi)	Polarization (H/V)	Result
3760	-51.36	-13	-38.36	-67.85	-57.66	2.51	8.81	V	Pass
5640	-37.87	-13	-24.87	-58.37	-45.58	2.99	10.70	V	Pass
7520	-40.94	-13	-27.94	-68.12	-49.47	3.59	12.12	V	Pass
11280	-36.29	-13	-23.29	-64.84	-45.33	4.27	13.31	V	Pass

Other harmonics are lower than background noise



<High Channel>

Band :	GSM1900	Temperature :	22~24°C
Test Mode :	GPRS class 8 Link (GMSK)	Relative Humidity :	45~52%
Channel :	810	Polarization :	Horizontal
Test Engineer :	Eric Shih		

Remark :

- Spurious emissions within 30-1000MHz were found more than 20dB below limit line.
- The harmonic (5th, 6th, 7th,...etc.) and other spurious are not reported, because those levels are lower than average limit line and background noise.

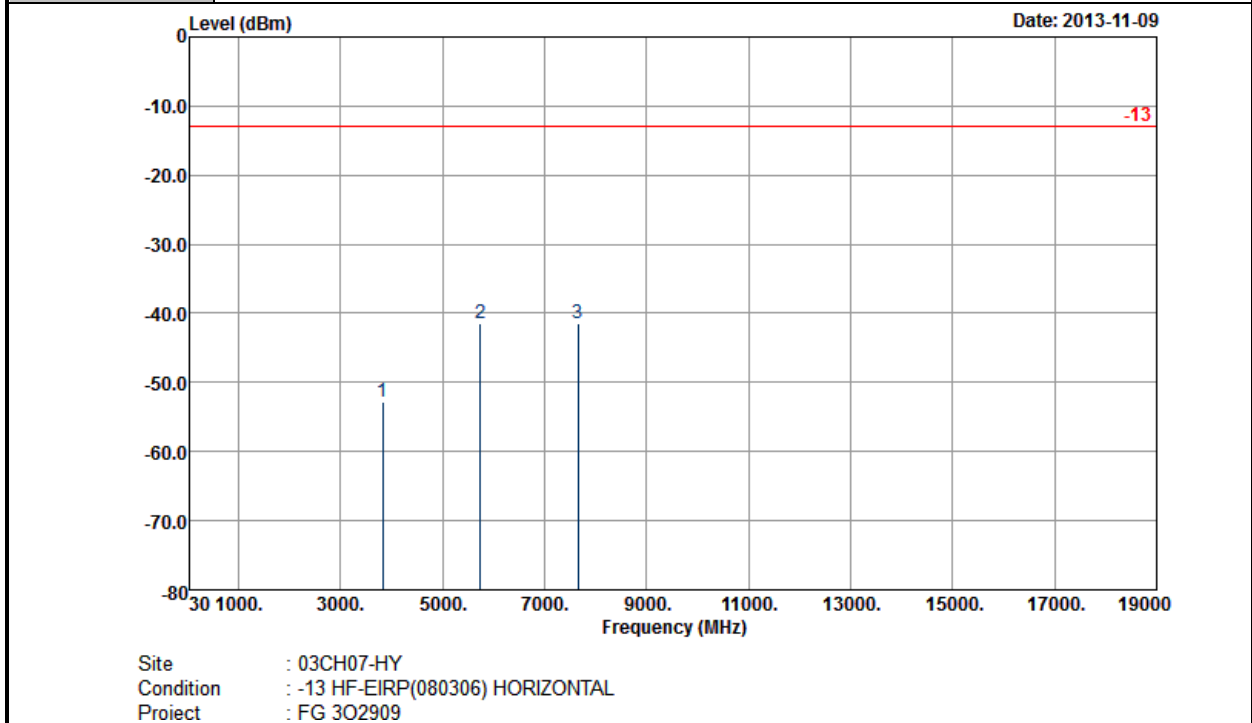

Site : 03CH07-HY
 Condition : -13 HF-EIRP(080306) HORIZONTAL
 Project : FG 3O2909

Frequency (MHz)	EIRP (dBm)	Limit (dBm)	Over Limit (dB)	SPA Reading (dBm)	S.G. Power (dBm)	TX Cable loss (dB)	TX Antenna Gain (dBi)	Polarization (H/V)	Result
3820	-52.87	-13	-39.87	-68.44	-59.28	2.47	8.88	H	Pass
5732	-41.43	-13	-28.43	-62.59	-49.13	3	10.70	H	Pass
7648	-41.39	-13	-28.39	-67.81	-50.17	3.43	12.21	H	Pass

Other harmonics are lower than background noise



Band :	GSM1900	Temperature :	22~24°C
Test Mode :	GPRS class 8 Link (GMSK)	Relative Humidity :	45~52%
Channel :	810	Polarization :	Vertical
Test Engineer :	Eric Shih		

Remark :

- Spurious emissions within 30-1000MHz were found more than 20dB below limit line.
- The harmonic (5th, 6th, 7th,...etc.) and other spurious are not reported, because those levels are lower than average limit line and background noise.

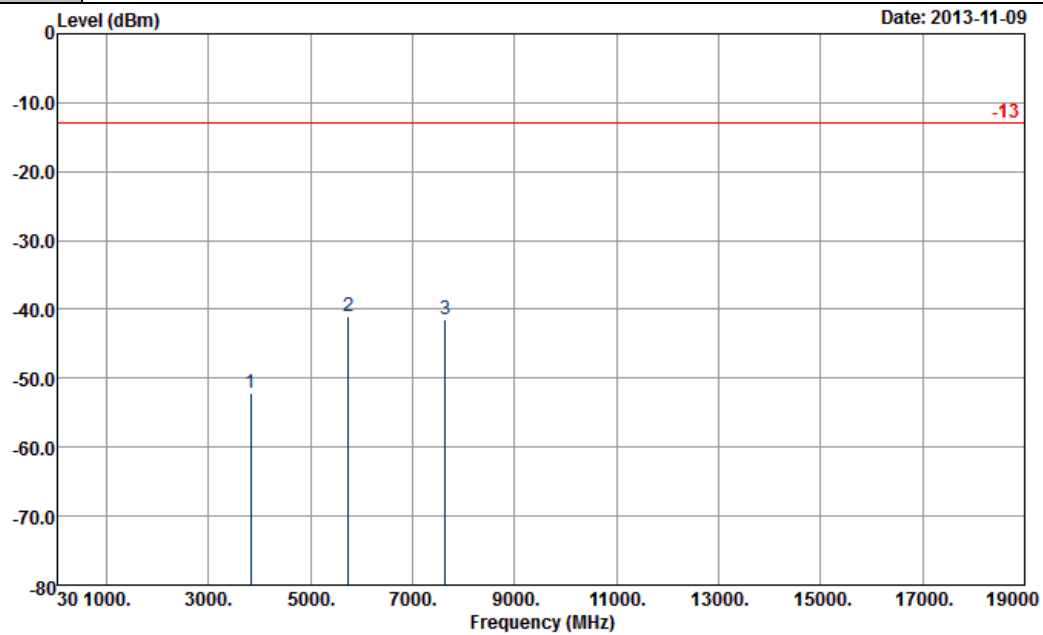

Site : 03CH07-HY
 Condition : -13 HF-EIRP(080306) VERTICAL
 Project : FG 3O2909

Frequency (MHz)	EIRP (dBm)	Limit (dBm)	Over Limit (dB)	SPA Reading (dBm)	S.G. Power (dBm)	TX Cable loss (dB)	TX Antenna Gain (dBi)	Polarization (H/V)	Result
3820	-52.07	-13	-39.07	-68.47	-58.48	2.47	8.88	V	Pass
5732	-41.09	-13	-28.09	-61.95	-48.79	3	10.70	V	Pass
7636	-41.54	-13	-28.54	-67.94	-50.32	3.43	12.21	V	Pass

Other harmonics are lower than background noise



<Low Channel>

Band :	GSM1900	Temperature :	22~24°C
Test Mode :	EDGE class 8 Link (8PSK)	Relative Humidity :	45~52%
Channel :	512	Polarization :	Horizontal
Test Engineer :	Eric Shih		

Remark :

- Spurious emissions within 30-1000MHz were found more than 20dB below limit line.
- The harmonic (5th, 6th, 7th,...etc.) and other spurious are not reported, because those levels are lower than average limit line and background noise.

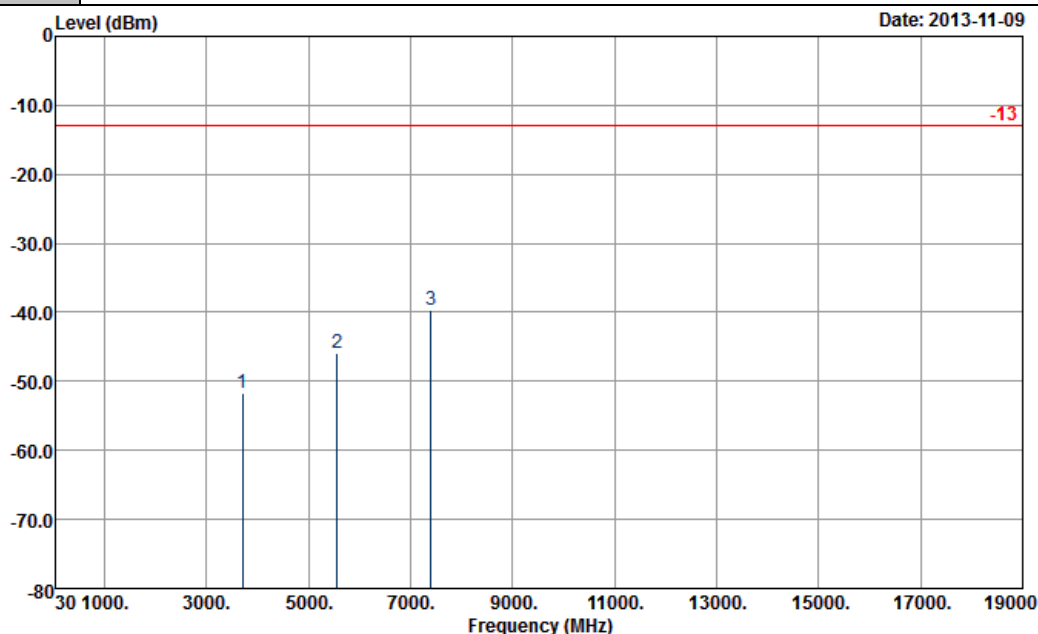

Site : 03CH07-HY
 Condition : -13 HF-EIRP(080306) HORIZONTAL
 Project : FG 3O2909

Frequency (MHz)	EIRP (dBm)	Limit (dBm)	Over Limit (dB)	SPA Reading (dBm)	S.G. Power (dBm)	TX Cable loss (dB)	TX Antenna Gain (dBi)	Polarization (H/V)	Result
3700	-51.78	-13	-38.78	-66.93	-57.93	2.59	8.74	H	Pass
5552	-46.01	-13	-33.01	-66.57	-53.67	3.04	10.70	H	Pass
7400	-39.67	-13	-26.67	-67.27	-48.41	3.28	12.02	H	Pass

Other harmonics are lower than background noise



Band :	GSM1900	Temperature :	22~24°C
Test Mode :	EDGE class 8 Link (8PSK)	Relative Humidity :	45~52%
Channel :	512	Polarization :	Vertical
Test Engineer :	Eric Shih		

Remark :

- Spurious emissions within 30-1000MHz were found more than 20dB below limit line.
- The harmonic (5th, 6th, 7th,...etc.) and other spurious are not reported, because those levels are lower than average limit line and background noise.

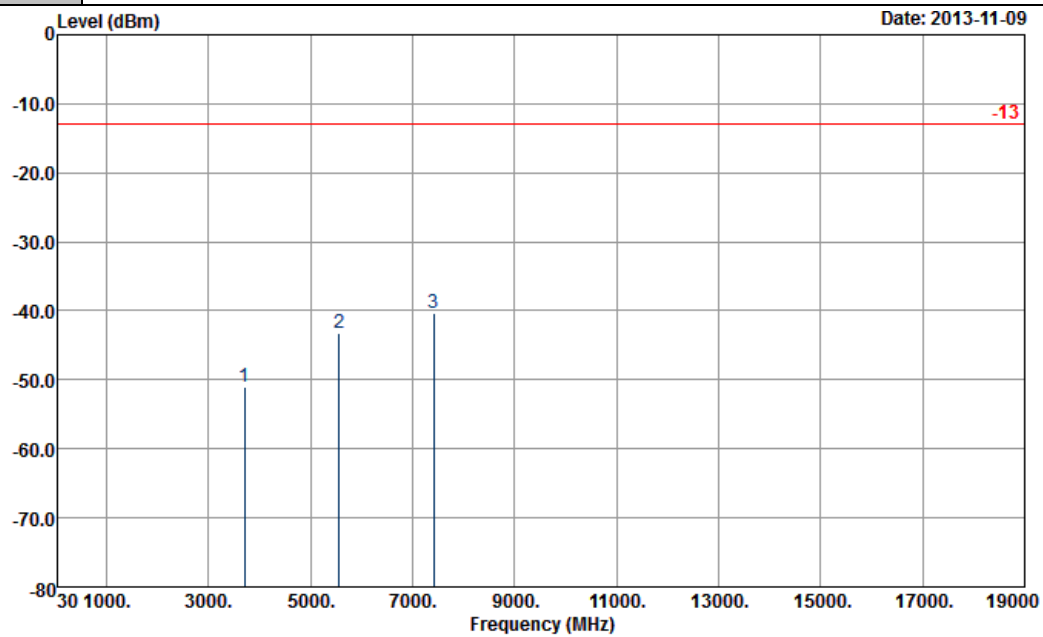

Site : 03CH07-HY
 Condition : -13 HF-EIRP(080306) VERTICAL
 Project : FG 3O2909

Frequency (MHz)	EIRP (dBm)	Limit (dBm)	Over Limit (dB)	SPA Reading (dBm)	S.G. Power (dBm)	TX Cable loss (dB)	TX Antenna Gain (dBi)	Polarization (H/V)	Result
3700	-51.11	-13	-38.11	-67.45	-57.26	2.59	8.74	V	Pass
5552	-43.26	-13	-30.26	-63.71	-50.92	3.04	10.70	V	Pass
7408	-40.44	-13	-27.44	-67.48	-49.18	3.28	12.02	V	Pass

Other harmonics are lower than background noise



<Middle Channel>

Band :	GSM1900	Temperature :	22~24°C
Test Mode :	EDGE class 8 Link (8PSK)	Relative Humidity :	45~52%
Channel :	661	Polarization :	Horizontal
Test Engineer :	Eric Shih		

Remark :

- Spurious emissions within 30-1000MHz were found more than 20dB below limit line.
- The harmonic (5th, 6th, 7th,...etc.) and other spurious are not reported, because those levels are lower than average limit line and background noise.

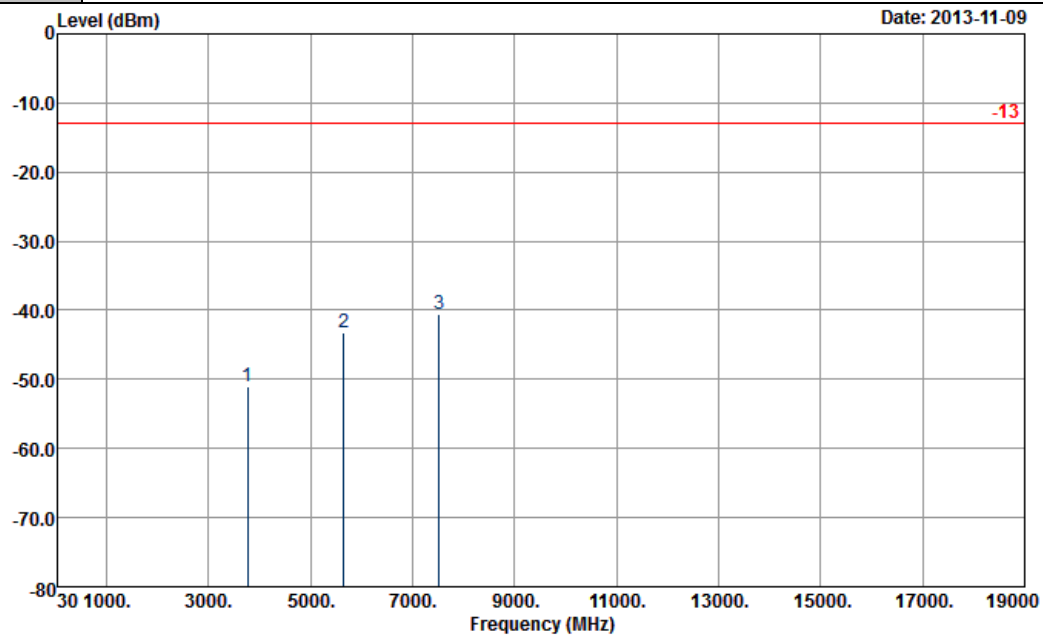

Site : 03CH07-HY
 Condition : -13 HF-EIRP(080306) HORIZONTAL
 Project : FG 302909

Frequency (MHz)	EIRP (dBm)	Limit (dBm)	Over Limit (dB)	SPA Reading (dBm)	S.G. Power (dBm)	TX Cable loss (dB)	TX Antenna Gain (dBi)	Polarization (H/V)	Result
3760	-51.06	-13	-38.06	-66.38	-57.36	2.51	8.81	H	Pass
5640	-43.18	-13	-30.18	-63.86	-50.89	2.99	10.70	H	Pass
7520	-40.59	-13	-27.59	-68.1	-49.12	3.59	12.12	H	Pass

Other harmonics are lower than background noise



Band :	GSM1900	Temperature :	22~24°C
Test Mode :	EDGE class 8 Link (8PSK)	Relative Humidity :	45~52%
Channel :	661	Polarization :	Vertical
Test Engineer :	Eric Shih		

Remark :

- Spurious emissions within 30-1000MHz were found more than 20dB below limit line.
- The harmonic (5th, 6th, 7th,...etc.) and other spurious are not reported, because those levels are lower than average limit line and background noise.

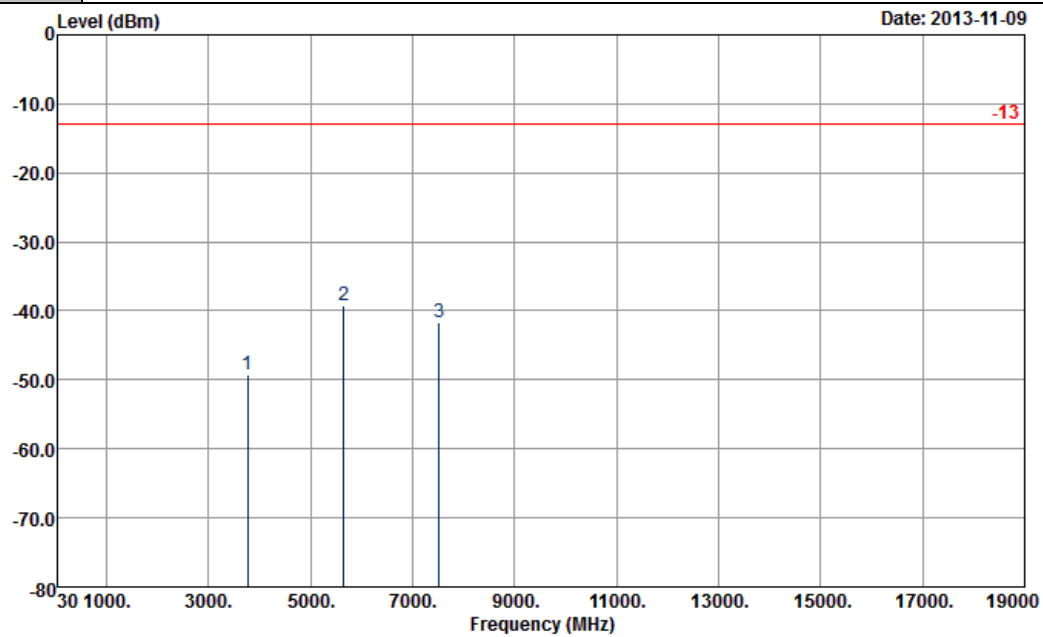

Site : 03CH07-HY
 Condition : -13 HF-EIRP(080306) VERTICAL
 Project : FG 302909

Frequency (MHz)	EIRP (dBm)	Limit (dBm)	Over Limit (dB)	SPA Reading (dBm)	S.G. Power (dBm)	TX Cable loss (dB)	TX Antenna Gain (dBi)	Polarization (H/V)	Result
3760	-49.28	-13	-36.28	-65.29	-55.58	2.51	8.81	V	Pass
5640	-39.30	-13	-26.30	-59.81	-47.01	2.99	10.70	V	Pass
7520	-41.70	-13	-28.70	-68.68	-50.23	3.59	12.12	V	Pass

Other harmonics are lower than background noise



<High Channel>

Band :	GSM1900	Temperature :	22~24°C
Test Mode :	EDGE class 8 Link (8PSK)	Relative Humidity :	45~52%
Channel :	810	Polarization :	Horizontal
Test Engineer :	Eric Shih		

Remark :

- Spurious emissions within 30-1000MHz were found more than 20dB below limit line.
- The harmonic (5th, 6th, 7th,...etc.) and other spurious are not reported, because those levels are lower than average limit line and background noise.

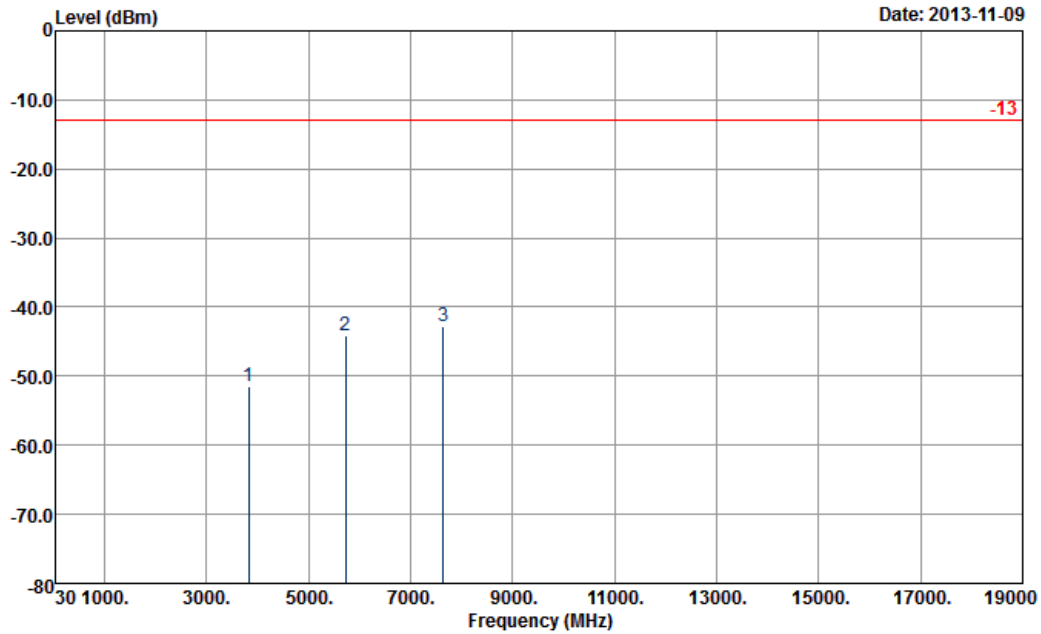

Site : 03CH07-HY
 Condition : -13 HF-EIRP(080306) HORIZONTAL
 Project : FG 3O2909

Frequency (MHz)	EIRP (dBm)	Limit (dBm)	Over Limit (dB)	SPA Reading (dBm)	S.G. Power (dBm)	TX Cable loss (dB)	TX Antenna Gain (dBi)	Polarization (H/V)	Result
3817	-51.49	-13	-38.49	-67.1	-57.9	2.47	8.88	H	Pass
5726	-44.10	-13	-31.10	-65.3	-51.8	3	10.70	H	Pass
7635	-42.72	-13	-29.72	-69.11	-51.5	3.43	12.21	H	Pass

Other harmonics are lower than background noise



Band :	GSM1900	Temperature :	22~24°C
Test Mode :	EDGE class 8 Link (8PSK)	Relative Humidity :	45~52%
Channel :	810	Polarization :	Vertical
Test Engineer :	Eric Shih		

Remark :

- Spurious emissions within 30-1000MHz were found more than 20dB below limit line.
- The harmonic (5th, 6th, 7th,...etc.) and other spurious are not reported, because those levels are lower than average limit line and background noise.

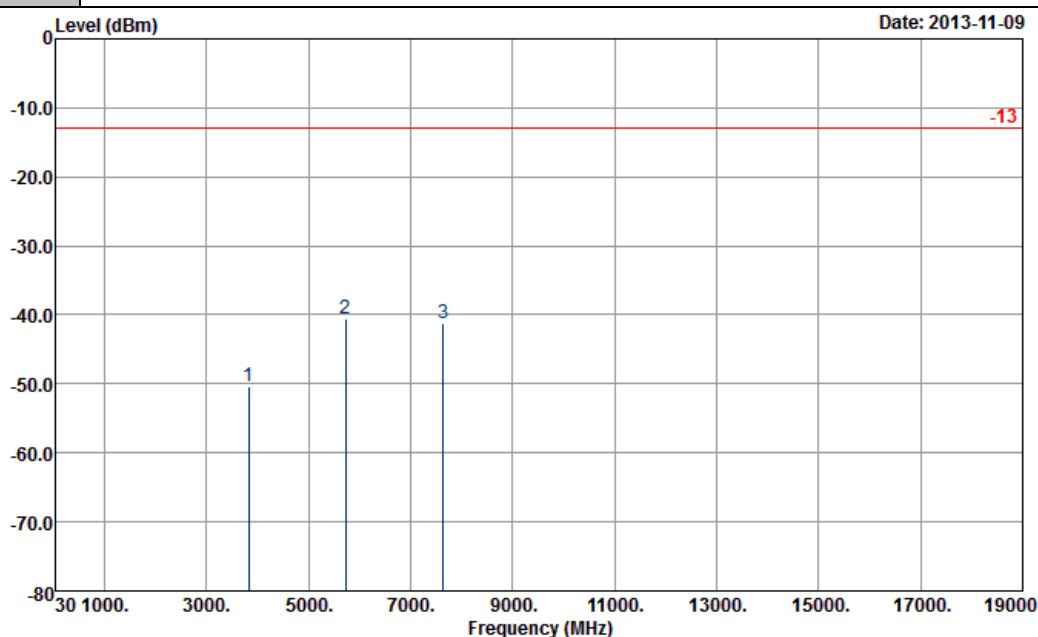

Site : 03CH07-HY
 Condition : -13 HF-EIRP(080306) VERTICAL
 Project : FG 302909

Frequency (MHz)	EIRP (dBm)	Limit (dBm)	Over Limit (dB)	SPA Reading (dBm)	S.G. Power (dBm)	TX Cable loss (dB)	TX Antenna Gain (dBi)	Polarization (H/V)	Result
3817	-50.39	-13	-37.39	-67.22	-56.8	2.47	8.88	V	Pass
5726	-40.60	-13	-27.60	-61.66	-48.3	3	10.70	V	Pass
7635	-41.32	-13	-28.32	-67.93	-50.1	3.43	12.21	V	Pass

Other harmonics are lower than background noise



<Low Channel>

Band :	WCDMA Band V	Temperature :	22~24°C
Test Mode :	RMC 12.2Kbps Link (QPSK)	Relative Humidity :	45~52%
Channel :	4132	Polarization :	Horizontal
Test Engineer :	Eric Shih		

Remark :

- Spurious emissions within 30-1000MHz were found more than 20dB below limit line.
- The harmonic (5th, 6th, 7th,...etc.) and other spurious are not reported, because those levels are lower than average limit line and background noise.

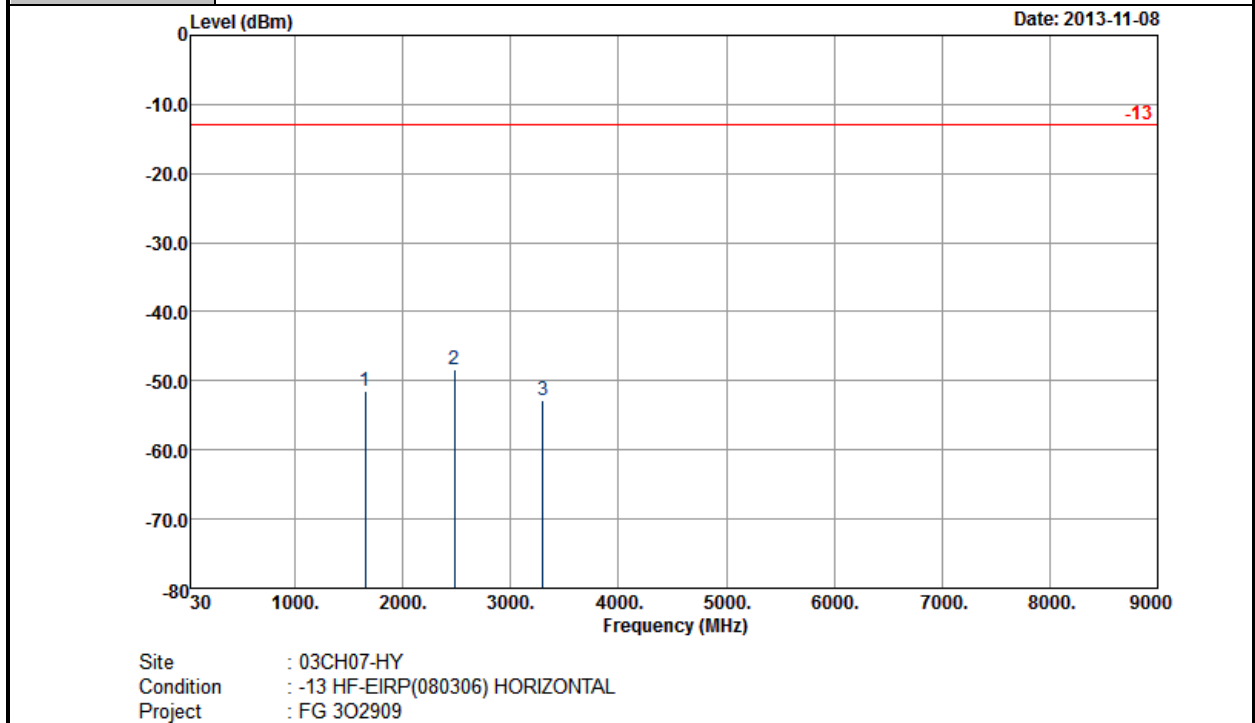

Frequency (MHz)	ERP (dBm)	Limit (dBm)	Over Limit (dB)	SPA Reading (dBm)	S.G. Power (dBm)	TX Cable loss (dB)	TX Antenna Gain (dBi)	Polarization (H/V)	Result
1651	-51.47	-13	-38.47	-60.2	-55.47	1.53	5.53	H	Pass
2476	-48.27	-13	-35.27	-61.65	-52.36	2.06	6.15	H	Pass
3301	-52.77	-13	-39.77	-66.82	-58.22	2.48	7.93	H	Pass

Other harmonics are lower than background noise



Band :	WCDMA Band V	Temperature :	22~24°C
Test Mode :	RMC 12.2Kbps Link (QPSK)	Relative Humidity :	45~52%
Channel :	4132	Polarization :	Vertical
Test Engineer :	Eric Shih		

Remark :

- Spurious emissions within 30-1000MHz were found more than 20dB below limit line.
- The harmonic (5th, 6th, 7th,...etc.) and other spurious are not reported, because those levels are lower than average limit line and background noise.

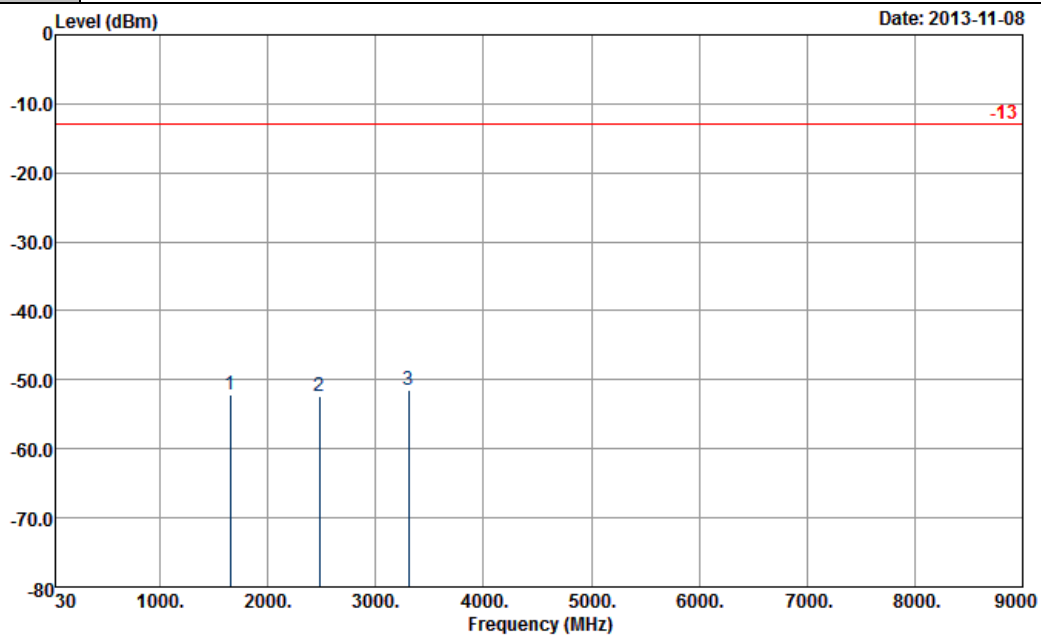

Site : 03CH07-HY
 Condition : -13 HF-EIRP(080306) VERTICAL
 Project : FG 302909

Frequency (MHz)	ERP (dBm)	Limit (dBm)	Over Limit (dB)	SPA Reading (dBm)	S.G. Power (dBm)	TX Cable loss (dB)	TX Antenna Gain (dBi)	Polarization (H/V)	Result
1651	-52.05	-13	-39.05	-63.06	-56.05	1.53	5.53	V	Pass
2479	-52.40	-13	-39.40	-65.86	-56.49	2.06	6.15	V	Pass
3303	-51.42	-13	-38.42	-66.92	-56.87	2.48	7.93	V	Pass

Other harmonics are lower than background noise



<Middle Channel>

Band :	WCDMA Band V	Temperature :	22~24°C
Test Mode :	RMC 12.2Kbps Link (QPSK)	Relative Humidity :	45~52%
Channel :	4182	Polarization :	Horizontal
Test Engineer :	Eric Shih		
Remark :	1. Spurious emissions within 30-1000MHz were found more than 20dB below limit line. 2. The harmonic (5 th , 6 th , 7 th ,...etc.) and other spurious are not reported, because those levels are lower than average limit line and background noise.		

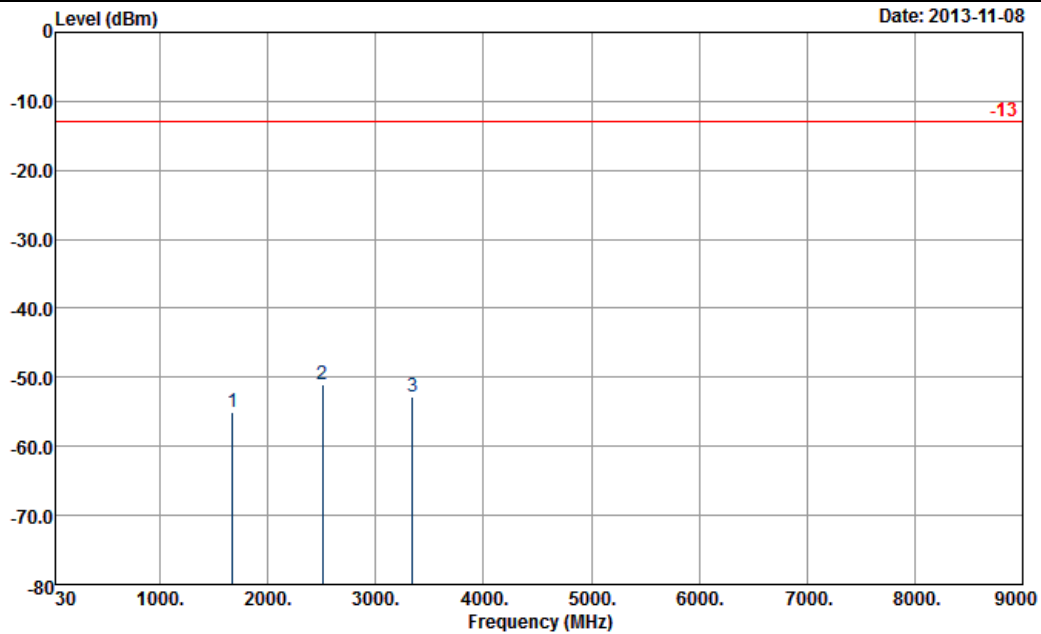

Site : 03CH07-HY
 Condition : -13 HF-EIRP(080306) HORIZONTAL
 Project : FG 3O2909

Frequency (MHz)	ERP (dBm)	Limit (dBm)	Over Limit (dB)	SPA Reading (dBm)	S.G. Power (dBm)	TX Cable loss (dB)	TX Antenna Gain (dBi)	Polarization (H/V)	Result
1675	-55.11	-13	-42.11	-64.01	-58.98	1.62	5.49	H	Pass
2506	-51.02	-13	-38.02	-64.23	-55.14	2.1	6.22	H	Pass
3343	-52.71	-13	-39.71	-66.81	-57.75	3.03	8.07	H	Pass

Other harmonics are lower than background noise



Band :	WCDMA Band V	Temperature :	22~24°C
Test Mode :	RMC 12.2Kbps Link (QPSK)	Relative Humidity :	45~52%
Channel :	4182	Polarization :	Vertical
Test Engineer :	Eric Shih		

Remark :

- Spurious emissions within 30-1000MHz were found more than 20dB below limit line.
- The harmonic (5th, 6th, 7th,...etc.) and other spurious are not reported, because those levels are lower than average limit line and background noise.

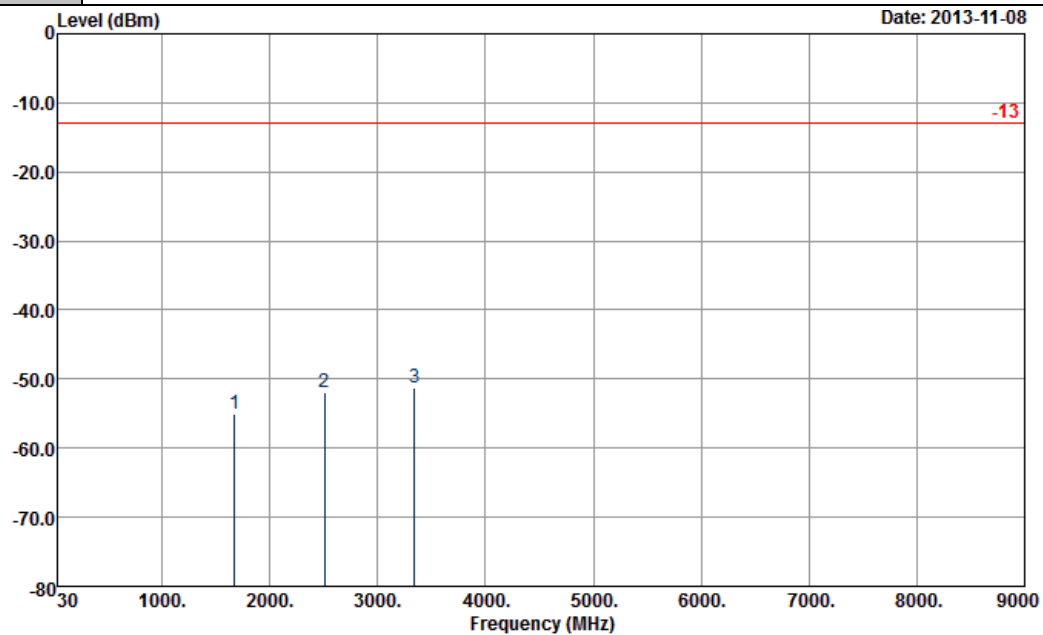

Site : 03CH07-HY
 Condition : -13 HF-EIRP(080306) VERTICAL
 Project : FG 3O2909

Frequency (MHz)	ERP (dBm)	Limit (dBm)	Over Limit (dB)	SPA Reading (dBm)	S.G. Power (dBm)	TX Cable loss (dB)	TX Antenna Gain (dBi)	Polarization (H/V)	Result
1675	-55.14	-13	-42.14	-66.31	-59.01	1.62	5.49	V	Pass
2509	-52.01	-13	-39.01	-65.65	-56.13	2.1	6.22	V	Pass
3343	-51.32	-13	-38.32	-67.07	-56.36	3.03	8.07	V	Pass

Other harmonics are lower than background noise



<High Channel>

Band :	WCDMA Band V	Temperature :	22~24°C
Test Mode :	RMC 12.2Kbps Link (QPSK)	Relative Humidity :	45~52%
Channel :	4233	Polarization :	Horizontal
Test Engineer :	Eric Shih		

Remark :

- Spurious emissions within 30-1000MHz were found more than 20dB below limit line.
- The harmonic (5th, 6th, 7th,...etc.) and other spurious are not reported, because those levels are lower than average limit line and background noise.

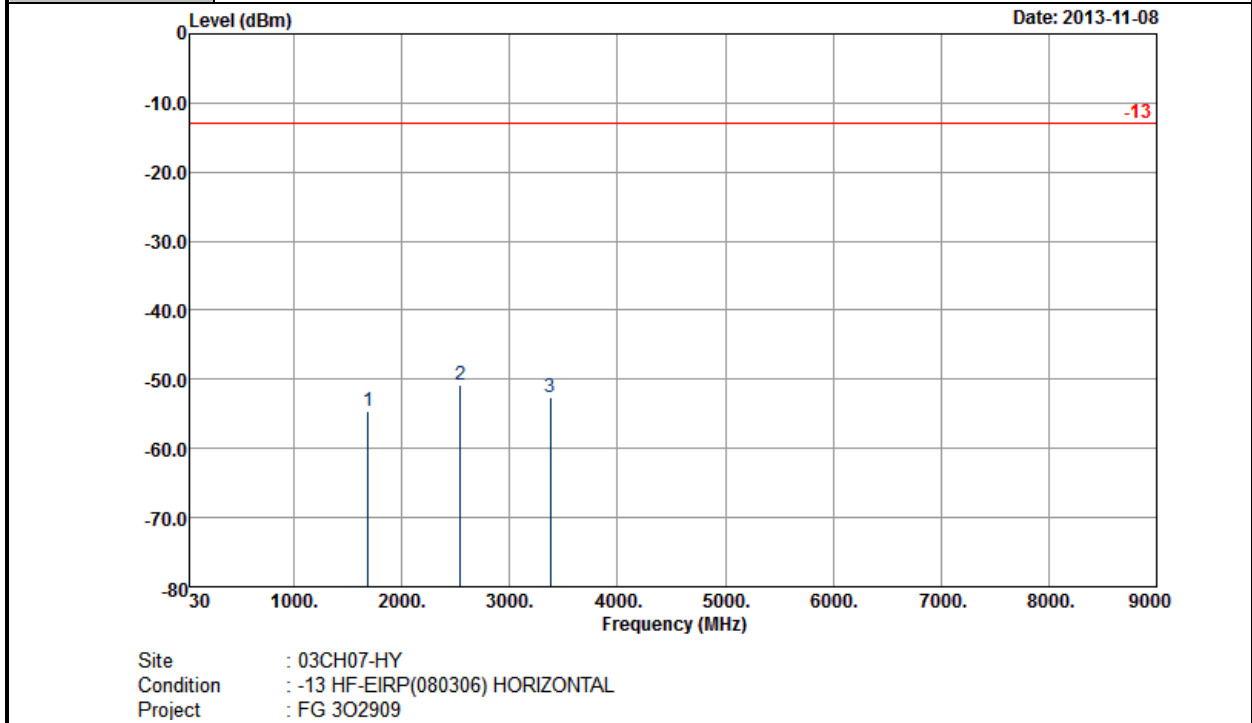

Frequency (MHz)	ERP (dBm)	Limit (dBm)	Over Limit (dB)	SPA Reading (dBm)	S.G. Power (dBm)	TX Cable loss (dB)	TX Antenna Gain (dBi)	Polarization (H/V)	Result
1690	-54.64	-13	-41.64	-63.72	-58.52	1.57	5.45	H	Pass
2542	-50.75	-13	-37.75	-63.94	-55.01	2.02	6.28	H	Pass
3380	-52.55	-13	-39.55	-66.7	-58.45	2.3	8.20	H	Pass

Other harmonics are lower than background noise



Band :	WCDMA Band V	Temperature :	22~24°C
Test Mode :	RMC 12.2Kbps Link (QPSK)	Relative Humidity :	45~52%
Channel :	4233	Polarization :	Vertical
Test Engineer :	Eric Shih		

Remark :

- Spurious emissions within 30-1000MHz were found more than 20dB below limit line.
- The harmonic (5th, 6th, 7th,...etc.) and other spurious are not reported, because those levels are lower than average limit line and background noise.

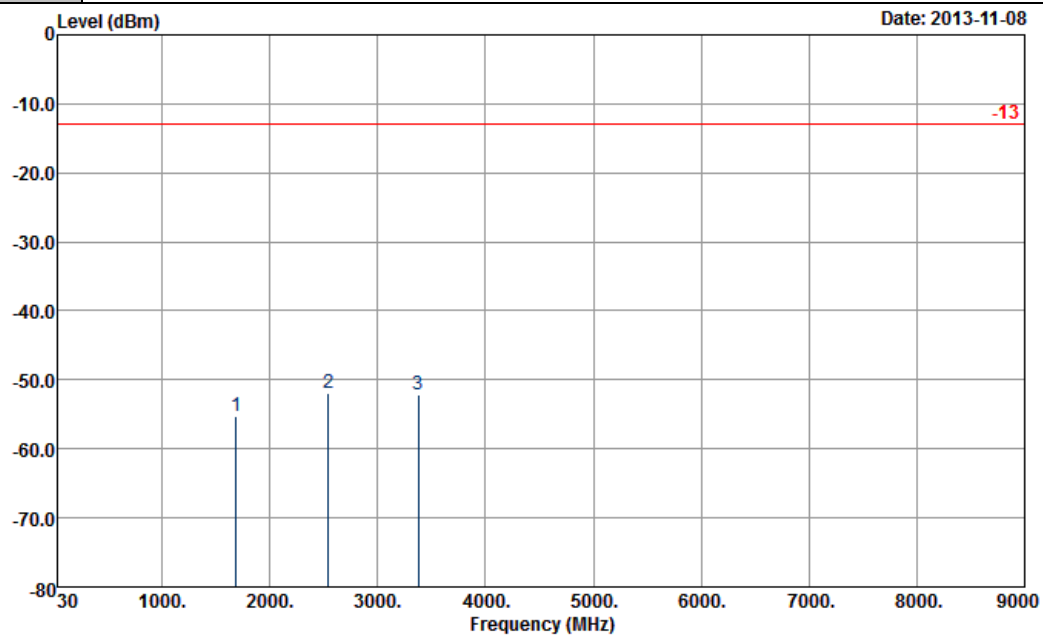

Site : 03CH07-HY
 Condition : -13 HF-EIRP(080306) VERTICAL
 Project : FG 302909

Frequency (MHz)	ERP (dBm)	Limit (dBm)	Over Limit (dB)	SPA Reading (dBm)	S.G. Power (dBm)	TX Cable loss (dB)	TX Antenna Gain (dBi)	Polarization (H/V)	Result
1690	-55.32	-13	-42.32	-66.42	-59.2	1.57	5.45	V	Pass
2542	-51.97	-13	-38.97	-65.81	-56.23	2.02	6.28	V	Pass
3379	-52.12	-13	-39.12	-67.66	-58.02	2.3	8.20	V	Pass

Other harmonics are lower than background noise



<Low Channel>

Band :	WCDMA Band II	Temperature :	22~24°C
Test Mode :	RMC 12.2Kbps Link (QPSK)	Relative Humidity :	45~52%
Channel :	9262	Polarization :	Horizontal
Test Engineer :	Eric Shih		

Remark :

- Spurious emissions within 30-1000MHz were found more than 20dB below limit line.
- The harmonic (5th, 6th, 7th,...etc.) and other spurious are not reported, because those levels are lower than average limit line and background noise.

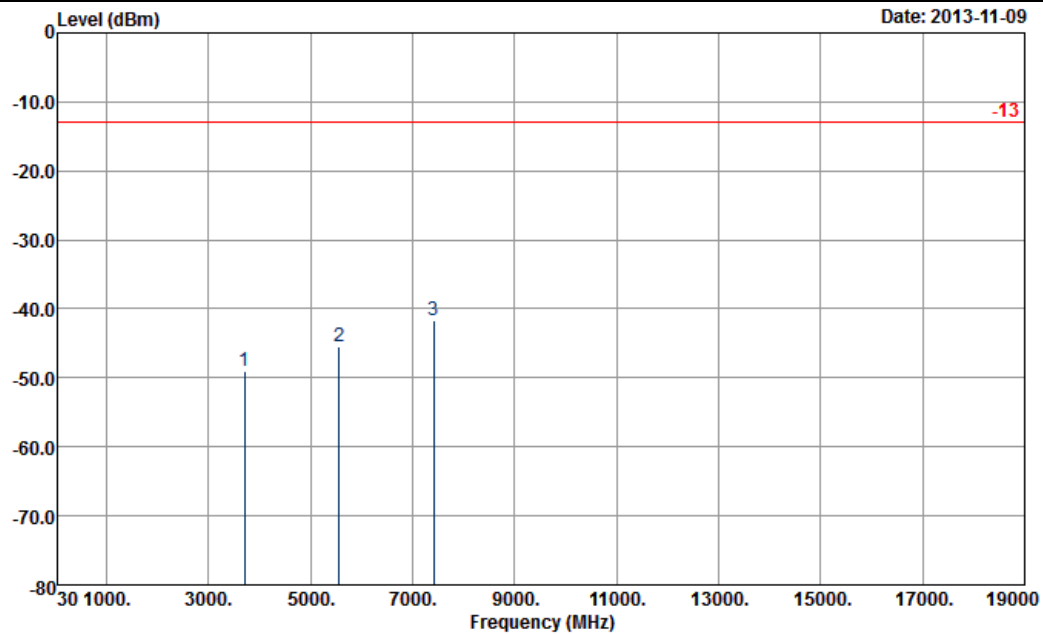

Site : 03CH07-HY
 Condition : -13 HF-EIRP(080306) HORIZONTAL
 Project : FG 3O2909

Frequency (MHz)	EIRP (dBm)	Limit (dBm)	Over Limit (dB)	SPA Reading (dBm)	S.G. Power (dBm)	TX Cable loss (dB)	TX Antenna Gain (dBi)	Polarization (H/V)	Result
3702	-49.05	-13	-36.05	-64.32	-55.2	2.59	8.74	H	Pass
5553	-45.54	-13	-32.54	-66.2	-53.2	3.04	10.70	H	Pass
7405	-41.66	-13	-28.66	-69.06	-50.4	3.28	12.02	H	Pass

Other harmonics are lower than background noise



Band :	WCDMA Band II	Temperature :	22~24°C
Test Mode :	RMC 12.2Kbps Link (QPSK)	Relative Humidity :	45~52%
Channel :	9262	Polarization :	Vertical
Test Engineer :	Eric Shih		

Remark :

- Spurious emissions within 30-1000MHz were found more than 20dB below limit line.
- The harmonic (5th, 6th, 7th,...etc.) and other spurious are not reported, because those levels are lower than average limit line and background noise.

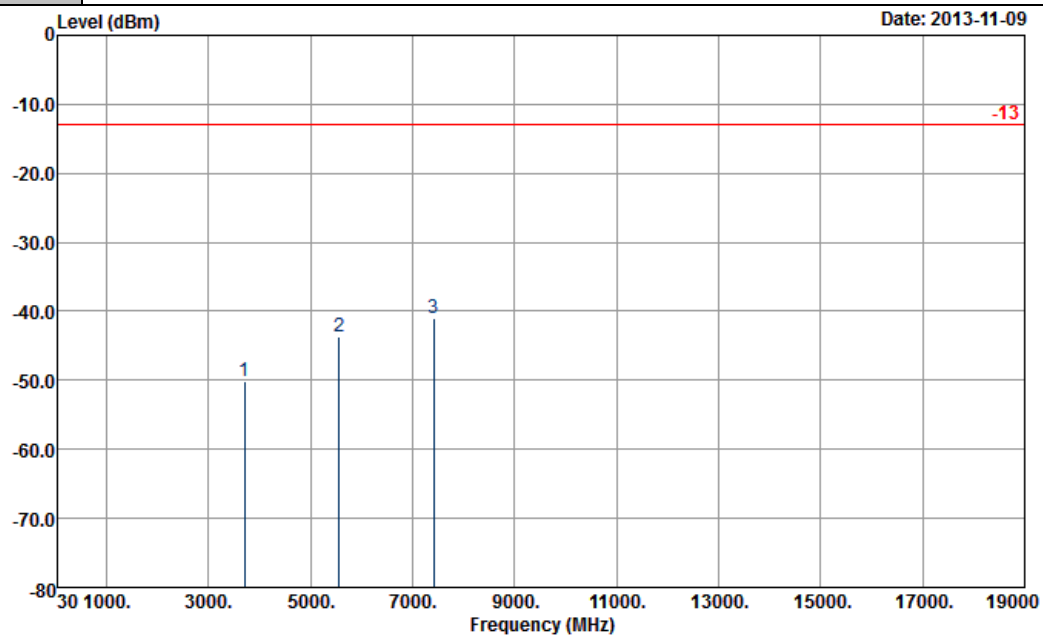

Site : 03CH07-HY
 Condition : -13 HF-EIRP(080306) VERTICAL
 Project : FG 3O2909

Frequency (MHz)	EIRP (dBm)	Limit (dBm)	Over Limit (dB)	SPA Reading (dBm)	S.G. Power (dBm)	TX Cable loss (dB)	TX Antenna Gain (dBi)	Polarization (H/V)	Result
3702	-50.15	-13	-37.15	-66.33	-56.3	2.59	8.74	V	Pass
5553	-43.74	-13	-30.74	-64.26	-51.4	3.04	10.70	V	Pass
7405	-41.06	-13	-28.06	-68.2	-49.8	3.28	12.02	V	Pass

Other harmonics are lower than background noise



<Middle Channel>

Band :	WCDMA Band II	Temperature :	22~24°C
Test Mode :	RMC 12.2Kbps Link (QPSK)	Relative Humidity :	45~52%
Channel :	9400	Polarization :	Horizontal
Test Engineer :	Eric Shih		

Remark :

- Spurious emissions within 30-1000MHz were found more than 20dB below limit line.
- The harmonic (5th, 6th, 7th,...etc.) and other spurious are not reported, because those levels are lower than average limit line and background noise.

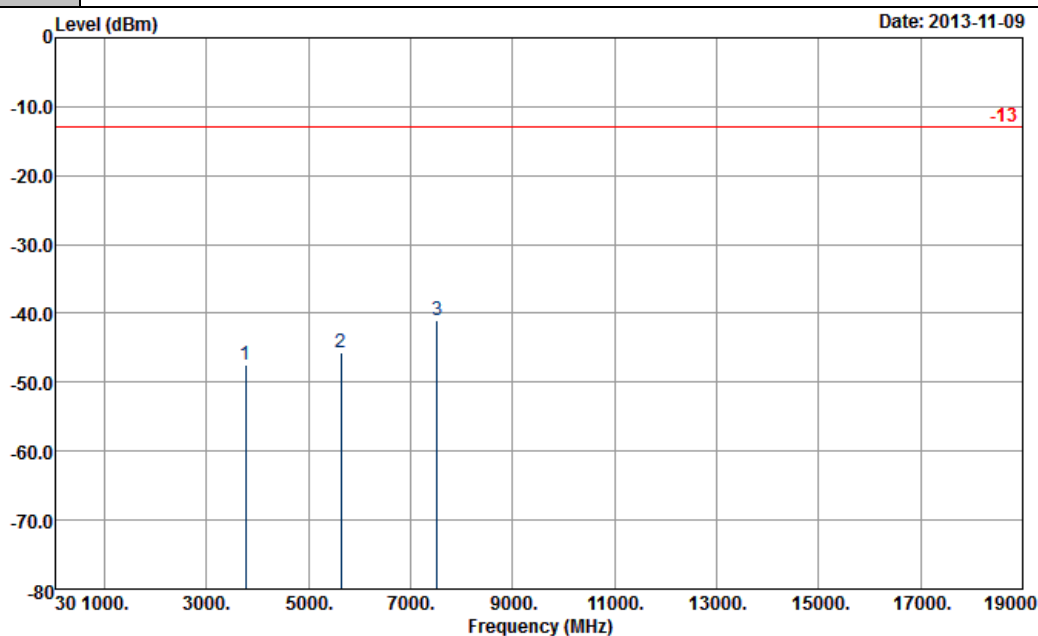

Site : 03CH07-HY
 Condition : -13 HF-EIRP(080306) HORIZONTAL
 Project : FG 3O2909

Frequency (MHz)	EIRP (dBm)	Limit (dBm)	Over Limit (dB)	SPA Reading (dBm)	S.G. Power (dBm)	TX Cable loss (dB)	TX Antenna Gain (dBi)	Polarization (H/V)	Result
3760	-47.50	-13	-34.50	-63.01	-53.8	2.51	8.81	H	Pass
5636	-45.79	-13	-32.79	-66.94	-53.5	2.99	10.70	H	Pass
7520	-40.97	-13	-27.97	-68.4	-49.5	3.59	12.12	H	Pass

Other harmonics are lower than background noise



Band :	WCDMA Band II	Temperature :	22~24°C
Test Mode :	RMC 12.2Kbps Link (QPSK)	Relative Humidity :	45~52%
Channel :	9400	Polarization :	Vertical
Test Engineer :	Eric Shih		

Remark :

- Spurious emissions within 30-1000MHz were found more than 20dB below limit line.
- The harmonic (5th, 6th, 7th,...etc.) and other spurious are not reported, because those levels are lower than average limit line and background noise.

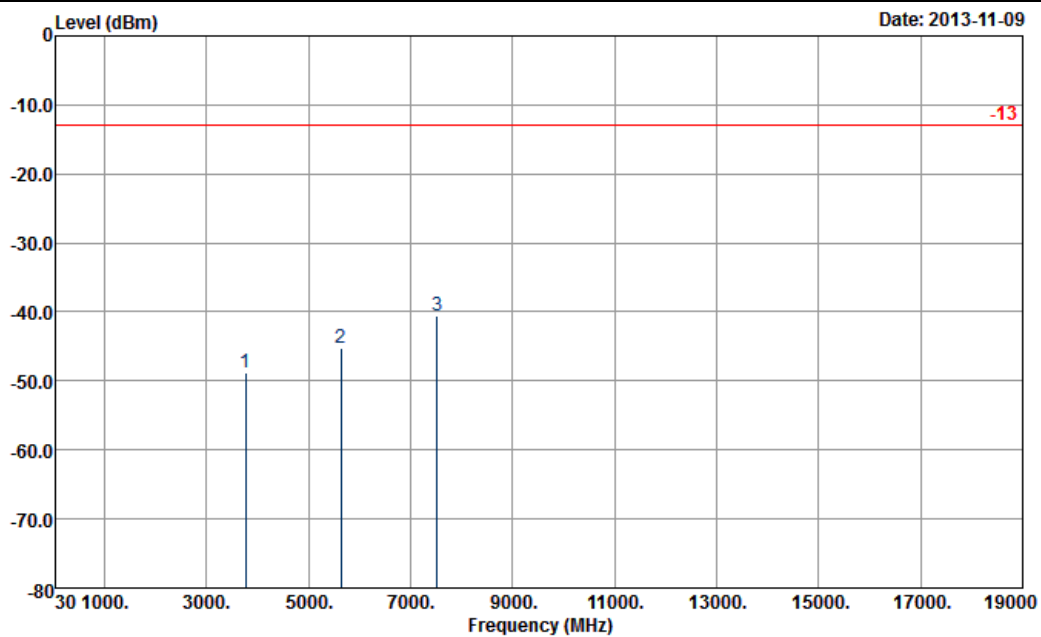

Site : 03CH07-HY
 Condition : -13 HF-EIRP(080306) VERTICAL
 Project : FG 302909

Frequency (MHz)	EIRP (dBm)	Limit (dBm)	Over Limit (dB)	SPA Reading (dBm)	S.G. Power (dBm)	TX Cable loss (dB)	TX Antenna Gain (dBi)	Polarization (H/V)	Result
3760	-48.80	-13	-35.80	-65.34	-55.1	2.51	8.81	V	Pass
5636	-45.19	-13	-32.19	-66	-52.9	2.99	10.70	V	Pass
7520	-40.57	-13	-27.57	-67.96	-49.1	3.59	12.12	V	Pass

Other harmonics are lower than background noise



<High Channel>

Band :	WCDMA Band II	Temperature :	22~24°C
Test Mode :	RMC 12.2Kbps Link (QPSK)	Relative Humidity :	45~52%
Channel :	9538	Polarization :	Horizontal
Test Engineer :	Eric Shih		

Remark :

- Spurious emissions within 30-1000MHz were found more than 20dB below limit line.
- The harmonic (5th, 6th, 7th,...etc.) and other spurious are not reported, because those levels are lower than average limit line and background noise.

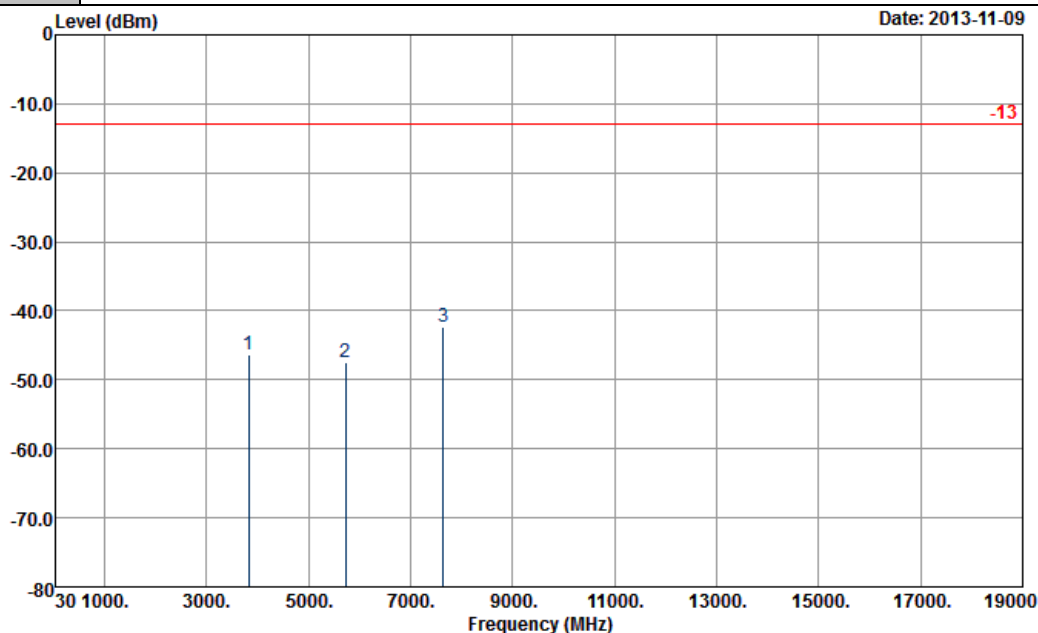

Site : 03CH07-HY
 Condition : -13 HF-EIRP(080306) HORIZONTAL
 Project : FG 3O2909

Frequency (MHz)	EIRP (dBm)	Limit (dBm)	Over Limit (dB)	SPA Reading (dBm)	S.G. Power (dBm)	TX Cable loss (dB)	TX Antenna Gain (dBi)	Polarization (H/V)	Result
3817	-46.29	-13	-33.29	-62.08	-52.7	2.47	8.88	H	Pass
5726	-47.40	-13	-34.40	-68.56	-55.1	3	10.70	H	Pass
7635	-42.32	-13	-29.32	-68.92	-51.1	3.43	12.21	H	Pass

Other harmonics are lower than background noise



Band :	WCDMA Band II	Temperature :	22~24°C
Test Mode :	RMC 12.2Kbps Link (QPSK)	Relative Humidity :	45~52%
Channel :	9538	Polarization :	Vertical
Test Engineer :	Eric Shih		

Remark :

- Spurious emissions within 30-1000MHz were found more than 20dB below limit line.
- The harmonic (5th, 6th, 7th,...etc.) and other spurious are not reported, because those levels are lower than average limit line and background noise.

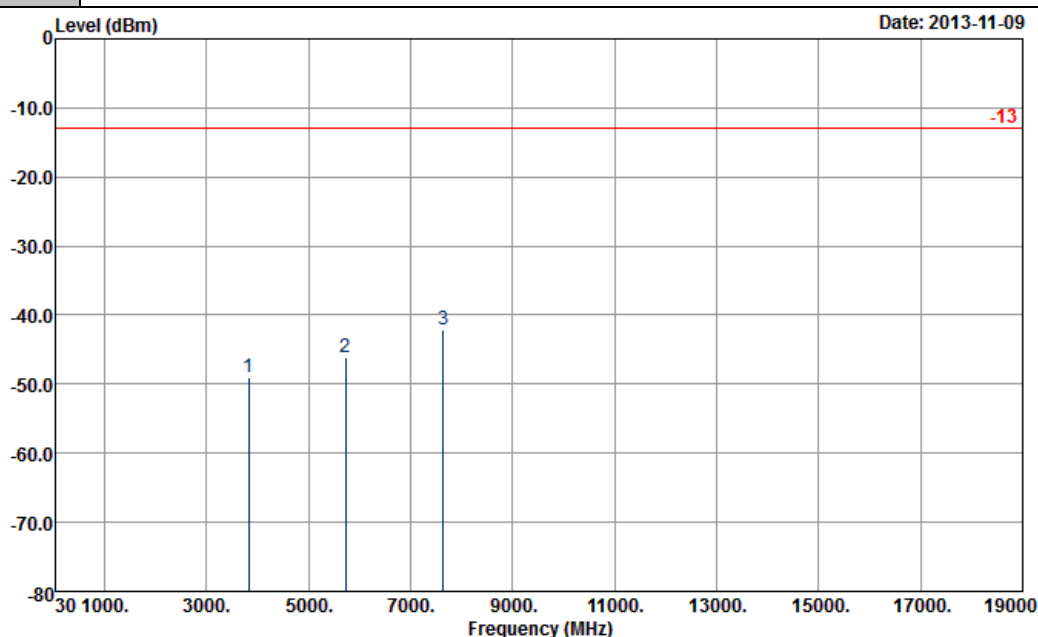

Site : 03CH07-HY
 Condition : -13 HF-EIRP(080306) VERTICAL
 Project : FG 302909

Frequency (MHz)	EIRP (dBm)	Limit (dBm)	Over Limit (dB)	SPA Reading (dBm)	S.G. Power (dBm)	TX Cable loss (dB)	TX Antenna Gain (dBi)	Polarization (H/V)	Result
3817	-48.99	-13	-35.99	-65.69	-55.4	2.47	8.88	V	Pass
5726	-46.20	-13	-33.20	-67.31	-53.9	3	10.70	V	Pass
7635	-42.12	-13	-29.12	-68.59	-50.9	3.43	12.21	V	Pass

Other harmonics are lower than background noise



3.8 Frequency Stability Measurement

3.8.1 Description of Frequency Stability Measurement

The frequency stability shall be measured by variation of ambient temperature and variation of primary supply voltage to ensure that the fundamental emission stays within the authorized frequency block. The frequency stability of the transmitter shall be maintained within $\pm 0.00025\%$ ($\pm 2.5\text{ppm}$) of the center frequency.

3.8.2 Measuring Instruments

The measuring equipment is listed in the section 4 of this test report.

3.8.3 Test Procedures for Temperature Variation

1. The EUT was set up in the thermal chamber and connected with the base station.
2. With power OFF, the temperature was decreased to -30°C and the EUT was stabilized before testing. Power was applied and the maximum change in frequency was recorded within one minute.
3. With power OFF, the temperature was raised in 10°C step up to 50°C . The EUT was stabilized at each step for at least half an hour. Power was applied and the maximum frequency change was recorded within one minute.

3.8.4 Test Procedures for Voltage Variation

1. The EUT was placed in a temperature chamber at $25\pm 5^{\circ}\text{C}$ and connected with the base station.
2. The power supply voltage to the EUT was varied from BEP to 115% of the nominal value measured at the input to the EUT.
3. The variation in frequency was measured for the worst case.

3.8.5 Test Setup

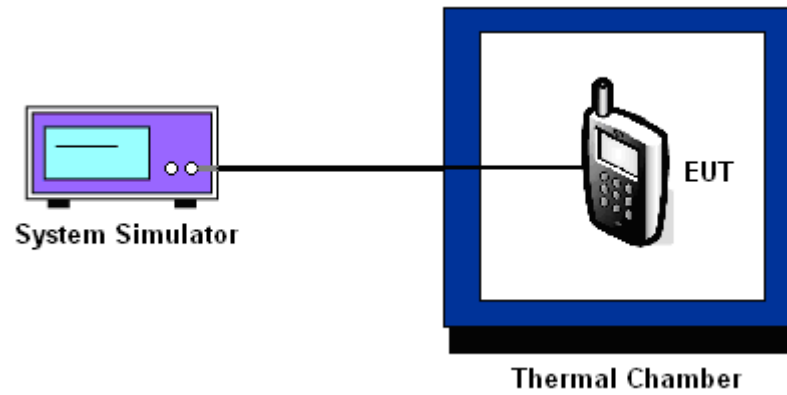



3.8.6 Test Result of Temperature Variation

Band :	GSM 850	Channel :	189
Limit (ppm) :	2.5	Frequency :	836.4 MHz

Temperature (°C)	GSM		EDGE class 8		Result
	Freq. Dev. (Hz)	Deviation (ppm)	Freq. Dev. (Hz)	Deviation (ppm)	
-30	-19	-0.022	-9	-0.011	PASS
-20	-15	-0.018	-11	-0.013	
-10	-11	-0.013	-15	-0.018	
0	-16	-0.019	-19	-0.022	
10	-21	-0.025	-13	-0.015	
20	-23	-0.027	-10	-0.012	
30	-9	-0.011	-7	-0.008	
40	-14	-0.016	-13	-0.015	
50	-13	-0.015	-15	-0.018	

Band :	GSM 1900	Channel :	661
Limit (ppm) :	2.5	Frequency :	1880.0 MHz

Temperature (°C)	GPRS class 8		EDGE class 8		Result
	Freq. Dev. (Hz)	Deviation (ppm)	Freq. Dev. (Hz)	Deviation (ppm)	
-30	39	0.021	26	0.014	PASS
-20	35	0.018	21	0.011	
-10	31	0.016	32	0.017	
0	25	0.013	25	0.013	
10	27	0.014	23	0.012	
20	29	0.015	21	0.011	
30	25	0.013	15	0.008	
40	21	0.011	17	0.009	
50	23	0.012	19	0.010	



Band :	WCDMA Band V	Channel :	4182
Limit (ppm) :	2.5	Frequency :	836.4 MHz

Temperature (°C)	RMC 12.2Kbps		Result
	Freq. Dev. (Hz)	Deviation (ppm)	
-30	3	0.004	PASS
-20	5	0.006	
-10	9	0.011	
0	11	0.013	
10	4	0.005	
20	13	0.015	
30	6	0.007	
40	7	0.008	
50	11	0.013	

Band :	WCDMA Band II	Channel :	9400
Limit (ppm) :	2.5	Frequency :	1880.0 MHz

Temperature (°C)	RMC 12.2Kbps		Result
	Freq. Dev. (Hz)	Deviation (ppm)	
-30	-10	-0.005	PASS
-20	-5	-0.003	
-10	-7	-0.004	
0	-13	-0.007	
10	-12	-0.006	
20	-11	-0.006	
30	-15	-0.008	
40	-16	-0.008	
50	-17	-0.009	



3.8.7 Test Result of Voltage Variation

Band & Channel	Mode	Voltage (Volt)	Freq. Dev. (Hz)	Deviation (ppm)	Limit (ppm)	Result
GSM 850 CH189	GSM	3.7	-19	-0.022	2.5	PASS
		BEP	-18	-0.021		
		4.2	-17	-0.020		
	EDGE class 8	3.7	-10	-0.012		
		BEP	-12	-0.014		
		4.2	-11	-0.013		
GSM 1900 CH661	GPRS class 8	3.7	41	0.022		
		BEP	44	0.023		
		4.2	36	0.019		
	EDGE class 8	3.7	30	0.016		
		BEP	34	0.018		
		4.2	27	0.014		
WCDMA Band V CH4182	RMC 12.2Kbps	3.7	6	0.007		
		BEP	7	0.008		
		4.2	5	0.006		
WCDMA Band II CH9400	RMC 12.2Kbps	3.7	-10	-0.005		
		BEP	-12	-0.006		
		4.2	-11	-0.006		

Note:

1. Normal Voltage = 3.7V.
2. Battery End Point (BEP) = 3.5 V.



4 List of Measuring Equipment

Instrument	Manufacturer	Model No.	Serial No.	Characteristics	Calibration Date	Test Date	Due Date	Remark
System Simulator	Rohde & Schwarz	CMU200	117995	N/A	Aug. 01, 2013	Nov. 01, 2013~ Dec. 03, 2013	Jul. 31, 2014	Conducted (TH02-HY)
Hygrometer	Testo	608-H1	34897199	N/A	May 07, 2013	Nov. 01, 2013~ Dec. 03, 2013	May 06, 2014	Conducted (TH02-HY)
Spectrum Analyzer	Rohde & Schwarz	FSP40	100055	9kHz~40GHz	Jun. 07, 2013	Nov. 01, 2013~ Dec. 03, 2013	Jun. 06, 2014	Conducted (TH02-HY)
Thermal Chamber	Ten Billion	TTH-D3SP	TBN-9307 01	N/A	Jul. 19, 2013	Nov. 01, 2013~ Dec. 03, 2013	Jul. 18, 2014	Conducted (TH02-HY)
Filter	WAINWRIGHT	whkx2..0/1 8g	N/A	2GHighPass Filter	Nov. 26, 2012	Nov. 01, 2013~ Nov. 24, 2013	Nov. 25, 2013	Conducted (TH02-HY)
Filter	WAINWRIGHT	whkx2..0/1 8g	N/A	2GHighPass Filter	Nov. 28, 2013	Nov. 28, 2013~ Dec. 03, 2013	Nov. 27, 2014	Conducted (TH02-HY)
RF cable	WOKEN	SMA(M)-S MA(M) for SS405	S05-13070 3-32	N/A	Jul. 09, 2013	Nov. 01, 2013~ Dec. 03, 2013	Jul. 08, 2014	Conducted (TH02-HY)
Spectrum Analyzer	Rohde & Schwarz	FSP30	101067	9kHz~30GHz	Nov. 30, 2012	Nov. 08, 2013~ Nov. 09, 2013	Nov. 29, 2013	Radiation (03CH07-HY)
Bilog Antenna	Schaffner	CBL6111C	2726	30MHz ~ 1GHz	Oct. 10, 2013	Nov. 08, 2013~ Nov. 09, 2013	Oct. 09, 2014	Radiation (03CH07-HY)
Double Ridge Horn Antenna	ESCO	3117	75962	1GHz~18GHz	Aug. 22, 2013	Nov. 08, 2013~ Nov. 09, 2013	Aug. 21, 2014	Radiation (03CH07-HY)
SHF-EHF Horn Antenna	SCHWARZBECK	BBHA 9170	BBHA9170 251	15GHz- 40GHz	Oct. 03, 2013	Nov. 08, 2013~ Nov. 09, 2013	Oct. 02, 2014	Radiation (03CH07-HY)
Preamplifier	COM-POWER	PA-103A	161241	30MHz~1GHz	Feb. 26, 2013	Nov. 08, 2013~ Nov. 09, 2013	Feb. 25, 2014	Radiation (03CH07-HY)
Preamplifier	Agilent	8449B	3008A023 62	1GHz~26.5GHz	Dec. 01, 2012	Nov. 08, 2013~ Nov. 09, 2013	Nov. 30, 2013	Radiation (03CH07-HY)
Turn Table	ChainTek	ChainTek 3000	N/A	0 ~ 360 degree	N/A	Nov. 08, 2013~ Nov. 09, 2013	N/A	Radiation (03CH07-HY)
Antenna Mast	ChainTek	ChainTek 3000	N/A	N/A	N/A	Nov. 08, 2013~ Nov. 09, 2013	N/A	Radiation (03CH07-HY)
High Pass Filter	Woken	1000-1275 0MHz	0100V1H0 10001G	1GHz HPF	Nov. 26, 2012	Nov. 08, 2013~ Nov. 09, 2013	Nov. 25, 2013	Radiation (03CH07-HY)
High Pass Filter	Microwave	H03G18G 3	N/A	3GHz HPF	Nov. 26, 2012	Nov. 08, 2013~ Nov. 09, 2013	Nov. 25, 2013	Radiation (03CH07-HY)
Notch Filter	Wainwright	WRCT 1800/2000 -20/40-10s sk	SN1	GSM 1900 / WCDMA Band 1,2 / LTE Band 2.25.33.35.36.37	Nov. 26, 2012	Nov. 08, 2013~ Nov. 09, 2013	Nov. 25, 2013	Radiation (03CH07-HY)
Notch Filter	Wainwright	WRCG 824/849/8	SN35	WCDMA 850	Nov. 26, 2012	Nov. 08, 2013~ Nov. 09, 2013	Nov. 25, 2013	Radiation (03CH07-HY)



Instrument	Manufacturer	Model No.	Serial No.	Characteristics	Calibration Date	Test Date	Due Date	Remark
HF RF Cable	HUBER SUHNER	SUCOFLEX 104	38411/6	1GHz ~ 18GHz	Dec.04 , 2012	Nov. 08, 2013~ Nov. 09, 2013	Dec. 03, 2013	Radiation (03CH07-HY)
LF RF Cable	Warison+HUBER SUHNER	WCBA-WC 04NM.NM2	N/A	30MHz ~ 1GHz	Dec.04 , 2012	Nov. 08, 2013~ Nov. 09, 2013	Dec. 03, 2013	Radiation (03CH07-HY)
Test Software	Audix	E3	Version 6.2009-08	N/A	N/A	Nov. 08, 2013~ Nov. 09, 2013	N/A	Radiation (03CH07-HY)
Hygrometer	Testo	608-H1	34897197	N/A	Nov. 20, 2012	Nov. 08, 2013~ Nov. 09, 2013	Nov. 19, 2013	Radiation (03CH07-HY)



5 Uncertainty of Evaluation

Uncertainty of Radiated Emission Measurement (30 MHz ~ 1000 MHz)

Measuring Uncertainty for a Level of Confidence of 95% ($U = 2Uc(y)$)	4.50
---	------