



SAR TEST REPORT

No. 2013SAR00048

For

Sony Mobile Communications (China) Co. Ltd

GSM/UMTS/LTE mobile phone

Type number: PM-0390-BV

Marketing name: C5306

With

Hardware Version: A

Software Version: 12.0.A.1.69 / s_atp_huashan_0_0_18_c (WLAN)

FCC ID: PY7PM-0390

IC: 4170B-PM0390

Issued Date: 2013-06-03



Note:

The test results in this test report relate only to the devices specified in this report. This report shall not be reproduced except in full without the written approval of TMC Beijing.

Test Laboratory:

TMC Beijing, Telecommunication Metrology Center of MIIT

No. 52, Huayuan Bei Road, Haidian District, Beijing, P. R. China 100191.

Tel:+86(0)10-62304633-2079, Fax:+86(0)10-62304633 Email:welcme@emcite.com. www.emcite.com

Revision Version

Report Number	Revision	Date	Memo
2013SAR00048	00	2013-04-02	Initial creation of test report
2013SAR00048	01	2013-05-08	<ol style="list-style-type: none"> 1. Add the standard of KDB941225 D01 and D02 in section 5.2 on page 10 2. Add the note for release version in section 4.1 on page 9 3. Add the information for DC-HSDPA in section 9.3 on page 24 4. Add the power tolerance for HSDPA in table 11.6 on page 30 5. Add the conducted power for HSDPA and DC-HSDPA in table 11.12 on page 33 6. Add the information of KDB inquiry for DC-HSDPA in section 11.3 on page 33 7. Add start RB and MPR in table 11.13 on page 34-42 and table 11.16 on page 45-51
2013SAR00048	02	2013-05-13	<ol style="list-style-type: none"> 1. Update the power tolerance of WCDMA1900 for HSUPA in table 11.6 on page 30 2. Retest some conducted power in section 11 3. Add the note of LTE MPR on page 28 and update the LTE MPR in table 11.16 on page 45 to 51
2013SAR00048	03	2013-05-22	<ol style="list-style-type: none"> 1. Update the table 2.1 on page 6 2. Update the evaluation of simultaneous in table 2.2 on page 7 and table 13.1 on page 54
2013SAR00048	04	2013-05-23	<ol style="list-style-type: none"> 1. Add the notes on page 6 2. Update the SAR value of DTS and UNII for WiFi in table 2.1 on page 6, table 2.2 on page 7 and table 13.1 on page 54
2013SAR00048	05	2013-06-03	<ol style="list-style-type: none"> 1. Add the measurements of WiFi 5G 2. Update the SAR value of DTS and UNII for WiFi in table 2.1 on page 6, table 2.2 on page 7 and table 13.1 on page 55 3. Add the note for test channels of 802.11a on page 65 4. Add the note for different software version on page 10 5. Add the statement for PBA of hotspot power back off on page 7

TABLE OF CONTENT

1 TEST LABORATORY	5
1.1 TESTING LOCATION	5
1.2 TESTING ENVIRONMENT.....	5
1.3 PROJECT DATA	5
1.4 SIGNATURE.....	5
2 STATEMENT OF COMPLIANCE	6
3 CLIENT INFORMATION.....	8
3.1 APPLICANT INFORMATION	8
3.2 MANUFACTURER INFORMATION	8
4 EQUIPMENT UNDER TEST (EUT) AND ANCILLARY EQUIPMENT (AE)	9
4.1 ABOUT EUT	9
4.2 INTERNAL IDENTIFICATION OF EUT USED DURING THE TEST	9
4.3 INTERNAL IDENTIFICATION OF AE USED DURING THE TEST.....	10
5 TEST METHODOLOGY	10
5.1 APPLICABLE LIMIT REGULATIONS	10
5.2 APPLICABLE MEASUREMENT STANDARDS.....	10
6 SPECIFIC ABSORPTION RATE (SAR).....	11
6.1 INTRODUCTION.....	11
6.2 SAR DEFINITION.....	11
7 TISSUE SIMULATING LIQUIDS.....	12
7.1 TARGETS FOR TISSUE SIMULATING LIQUID	12
7.2 DIELECTRIC PERFORMANCE	12
8 SYSTEM VERIFICATION.....	20
8.1 SYSTEM SETUP.....	20
8.2 SYSTEM VERIFICATION.....	21
9 MEASUREMENT PROCEDURES	22
9.1 TESTS TO BE PERFORMED	22
9.2 GENERAL MEASUREMENT PROCEDURE.....	24
9.3 WCDMA MEASUREMENT PROCEDURES FOR SAR	25
9.4 SAR MEASUREMENT FOR LTE.....	26
9.5 BLUETOOTH & WI-FI MEASUREMENT PROCEDURES FOR SAR	26
9.6 POWER DRIFT.....	26
10 AREA SCAN BASED 1-G SAR	27
10.1 REQUIREMENT OF KDB.....	27
10.2 FAST SAR ALGORITHMS	27
11 CONDUCTED OUTPUT POWER.....	28

11.1 MANUFACTURING TOLERANCE	28
11.2 GSM MEASUREMENT RESULT	32
11.3 WCDMA MEASUREMENT RESULT.....	34
11.4 LTE MEASUREMENT RESULT	35
11.5 WI-FI AND BT MEASUREMENT RESULT	43
11.6 HOTSPOT	45
12 SIMULTANEOUS TX SAR CONSIDERATIONS	53
12.1 INTRODUCTION.....	53
12.2 TRANSMIT ANTENNA SEPARATION DISTANCES	53
12.3 SAR MEASUREMENT POSITIONS	53
12.4 STANDALONE SAR TEST EXCLUSION CONSIDERATIONS	54
13 EVALUATION OF SIMULTANEOUS.....	55
14 SAR TEST RESULT.....	56
14.1 SAR RESULTS FOR FAST SAR.....	56
14.2 SAR RESULTS FOR STANDARD PROCEDURE.....	66
15 SAR MEASUREMENT VARIABILITY.....	71
16 MEASUREMENT UNCERTAINTY	73
17 MAIN TEST INSTRUMENTS	77
ANNEX A GRAPH RESULTS.....	78
ANNEX B SYSTEM VERIFICATION RESULTS.....	127
ANNEX C SAR MEASUREMENT SETUP	142
ANNEX D POSITION OF THE WIRELESS DEVICE IN RELATION TO THE PHANTOM	148
ANNEX E EQUIVALENT MEDIA RECIPES	151
ANNEX F SYSTEM VALIDATION	152
ANNEX G PROBE CALIBRATION CERTIFICATE	153
ANNEX H DIPOLE CALIBRATION CERTIFICATE.....	175

1 Test Laboratory

1.1 Testing Location

Company Name: TMC Beijing, Telecommunication Metrology Center of MIIT
Address: No 52, Huayuan beilu, Haidian District, Beijing, P.R.China
Postal Code: 100191
Telephone: +86-10-62304633
Fax: +86-10-62304793

1.2 Testing Environment

Temperature: 18°C~25 °C,
Relative humidity: 30%~ 70%
Ground system resistance: < 0.5 Ω
Ambient noise & Reflection: < 0.012 W/kg

1.3 Project Data

Project Leader: Qi Dianyuan
Test Engineer: Lin Xiaojun
Testing Start Date: March 16, 2013
Testing End Date: May 26, 2013

1.4 Signature



Lin Xiaojun
(Prepared this test report)

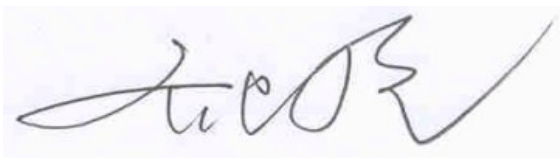

Qi Dianyuan
(Reviewed this test report)



Xiao Li
Deputy Director of the laboratory
(Approved this test report)

2 Statement of Compliance

The maximum results of SAR found during testing for Sony Mobile Communications (China) Co. Ltd GSM/UMTS/LTE mobile phone PM-0390-BV / C5306 are as follows:

Table 2.1: Highest Reported SAR (1g)

Exposure Configuration	Technology Band	Highest Reported SAR 1g (W/Kg)	Equipment Class
Head (Separation Distance 0mm)	GSM 850	0.61	PCE
	PCS 1900	0.30	
	UMTS FDD 2	0.52	
	UMTS FDD 5	0.52	
	LTE Band 2	0.49	
	LTE Band 4	0.67	
	LTE Band 5	0.52	
	WLAN 2.4&5.8 GHz	0.23	DTS
	WLAN 5 GHz	0.05	UNII
Hotspot (Separation Distance 10mm)	GSM 850	0.83	PCE
	PCS 1900	1.05	
	UMTS FDD 2	1.06	
	UMTS FDD 5	0.69	
	LTE Band 2	1.15	
	LTE Band 4	1.15	
	LTE Band 5	0.54	
	WLAN 2.4&5.8 GHz	0.13	DTS
	WLAN 5 GHz	0.07	UNII
Body-worn (Data) (Separation Distance 15mm)	GSM 850	/	PCE
	PCS 1900	0.77	
	UMTS FDD 2	1.33	
	UMTS FDD 5	/	
	LTE Band 2	1.24	
	LTE Band 4	1.14	
	LTE Band 5	/	
	WLAN 2.4&5.8 GHz	/	DTS
	WLAN 5 GHz	/	UNII
Body-worn (Speech) (Separation Distance 15mm)	GSM 850	0.60	PCE
	PCS 1900	0.74	
	UMTS FDD 2	1.31	
	UMTS FDD 5	0.49	
	LTE Band 2	/	
	LTE Band 4	/	
	LTE Band 5	/	
	WLAN 2.4&5.8 GHz	/	DTS
	WLAN 5 GHz	/	UNII

Note1: For the bands without power reduction, the SAR values with 10mm are more conservative than the values with 15mm. So these bands are only tested with 10mm for data and 15mm for speech.

Note2: it can't use with speech in the body position for the mode of LTE and WLAN.

The SAR values found for the Mobile Phone are below the maximum recommended levels of 1.6 W/Kg as averaged over any 1g tissue according to the ANSI C95.1-1999.

For body worn operation, this device has been tested and meets FCC RF exposure guidelines when used with any accessory that contains no metal and which provides a minimum separation distance of 10 mm for data and 15mm for speech between this device and the body of the user. Use of other accessories may not ensure compliance with FCC RF exposure guidelines.

The EUT battery must be fully charged and checked periodically during the test to ascertain uniform power output.

The measurement together with the test system set-up is described in annex C of this test report. A detailed description of the equipment under test can be found in chapter 4 of this test report.

The highest reported SAR value is obtained at the case of (**Table 2.1**), and the values are: **1.33 W/kg (1g)**.

Table 2.2: The sum of reported SAR values for main antenna and WiFi

	Position	GSM/WCDMA	WiFi (DTS)	Sum1	WiFi (UNII)	Sum2
Maximum reported SAR value for Head	Right hand, Touch cheek	0.67	0.23	0.90	0.05	0.72
Maximum reported SAR value for Body	Front	1.33	0.03	1.36	/	/
	Rear	0.76	0.13	0.89	0.07	0.83

Note1: Sum1 is GSM/WCDMA + WiFi (DTS). Sum2 is GSM/WCDMA + WiFi (UNII).

Table 2.3: The sum of reported SAR values for main antenna and Bluetooth

	Position	Main antenna	BT*	Sum
Maximum reported SAR value for Head	Right hand, Touch cheek	0.67	0.26	0.93
Maximum reported SAR value for Body	Front	1.33	0.26	1.59

BT* - Estimated SAR for Bluetooth (see the table 13.3)

According to the above tables, the highest sum of reported SAR values is **1.59 W/kg (1g)**. The detail for simultaneous transmission consideration is described in chapter 13.

PBA of hotspot power back off is not required as FCC's response of KDB inquiry, and there is one Main antenna working for the transmission of 2G/3G/4G, and neither voice nor data of 2G/3G/4G can transmit simultaneously with each other. Another specific BT/WLAN antenna is working for all transmission modes of BT/WLAN and any transmission mode of BT/WLAN cannot work simultaneously with each other. Main antenna and BT/WLAN antenna can work at the same time.

3 Client Information

3.1 Applicant Information

Company Name: Sony Mobile Communications (China) Co. Ltd
Address /Post: Sony Mobile R&D Center, No. 16, Guangshun South Street,
Chaoyang District
City: Beijing
Postal Code: 100102
Country: China
Contact Person: Ma, Gang
Telephone: +86-10-58656312
Fax: +86-10-58659049

3.2 Manufacturer Information

Company Name: Sony Mobile Communications (China) Co. Ltd
Address /Post: Sony Mobile R&D Center, No. 16, Guangshun South Street,
Chaoyang District
City: Beijing
Postal Code: 100102
Country: China
Contact Person: Ma, Gang
Telephone: +86-10-58656312
Fax: +86-10-58659049

4 Equipment Under Test (EUT) and Ancillary Equipment (AE)

4.1 About EUT

Description:	GSM/UMTS/LTE mobile phone
Type name:	PM-0390-BV
Marketing name:	C5306
Operating mode(s):	GSM 850/900/1800/1900, WCDMA 850/900/1900/2100 BT, Wi-Fi (2.4G&5G), LTE Band 1/2/4/5
Tested Tx Frequency:	825 – 848.8 MHz (GSM 850)
	1850.2 – 1910 MHz (GSM 1900)
	826.4–846.6 MHz (WCDMA850 Band V)
	1852.4–1907.6 MHz (WCDMA1900 Band II)
	1860 – 1900 MHz (LTE Band 2)
	1720 – 1745 MHz (LTE Band 4)
	829 – 844 MHz (LTE Band 5)
	2412 – 2462 MHz (Wi-Fi 2.4G) 5180 – 5825 MHz (Wi-Fi 5G)
GPRS/EGPRS Multislot Class:	33
GPRS capability Class:	B
WCDMA UE Category:	6
Release Version:	GSM: R8
	GPRS: R8
	UMTS: R8 (HSPA+ and DC-HSDPA only support downlink)
	LTE: R9
Test device Production information:	Production unit
Device type:	Portable device
Antenna type:	Integrated antenna
Accessories/Body-worn configurations:	Headset
Hotspot mode:	Support simultaneous transmission of hotspot and voice(or data)
Form factor:	13.1cm × 6.7 cm
Antenna dimension:	Max length: 53 mm
	Max width: 8 mm

4.2 Internal Identification of EUT used during the test

EUT ID*	IMEI	SN	HW Version	SW Version
EUT1	004402450782994	CB5123JXXR	A	12.0.A.1.69
EUT2	004402450782911	CB5123JXYY	A	12.0.A.1.69
EUT3	004402450782465	CB5123JXYT	A	12.0.A.1.69
EUT4	004402450783331	CB5123JXWV	A	s_atp_huashan_0_0_18_c
EUT5	004402450783315	CB5123JY0U	A	s_atp_huashan_0_0_18_c

*EUT ID: is used to identify the test sample in the lab internally.

Note1: It is performed to test SAR with the EUT1, 2 and 4, conducted power of main antenna with the EUT3 and conducted power of WLAN antenna with the EUT5.

Note2: There are different software version between the SAR sample and the WLAN sample. Because the SAR sample is controlled to work by Digital Radio Communication tester, the WLAN sample is controlled to work by the terminal software installed on the PC.

4.3 Internal Identification of AE used during the test

AE ID*	Description	Model	SN	Manufacturer
AE1	Headset	MH410c	/	Foster

*AE ID: is used to identify the test sample in the lab internally.

5 TEST METHODOLOGY

5.1 Applicable Limit Regulations

ANSI C95.1–1999: IEEE Standard for Safety Levels with Respect to Human Exposure to Radio Frequency Electromagnetic Fields, 3 kHz to 300 GHz.

It specifies the maximum exposure limit of **1.6 W/kg** as averaged over any 1 gram of tissue for portable devices being used within 20 cm of the user in the uncontrolled environment.

5.2 Applicable Measurement Standards

IC RSS-102: Radio Frequency (RF) Exposure Compliance of Radio communication Apparatus (All Frequency Bands)

IEEE 1528–2003: Recommended Practice for Determining the Peak Spatial-Average Specific Absorption Rate (SAR) in the Human Body Due to Wireless Communications Devices: Experimental Techniques.

OET Bulletin 65 (Edition 97-01) and Supplement C(Edition 01-01): Additional Information for Evaluating Compliance of Mobile and Portable Devices with FCC Limits.

KDB447498 D01: General RF Exposure Guidance v05: Mobile and Portable Devices RF Exposure Procedures and Equipment Authorization Policies.

KDB648474 D04 SAR Handsets Multi Xmitter and Ant v01: SAR Evaluation Considerations for Wireless Handsets.

KDB941225 D01 SAR test for 3G devices v02: SAR Measurement Procedures for 3G Devices

KDB941225 D02 Guidance for 3GPP R6 and R7 HSPA v02v01: 3GPP R6 HSPA and R7 HSPA+ SAR Guidance

KDB941225 D05 SAR for LTE Devices v02: SAR Evaluation Considerations for LTE Devices

KDB941225 D06 Hot Spot SAR v01: SAR Evaluation Procedures for Portable Devices with Wireless Router Capabilities

KDB248227: SAR measurement procedures for 802.112abg transmitters

KDB865664 D01 SAR measurement 100 MHz to 6 GHz v01: SAR Measurement Requirements for 100 MHz to 6 GHz

KDB865664 D02 SAR Reporting v01: RF Exposure Compliance Reporting and Documentation Considerations

6 Specific Absorption Rate (SAR)

6.1 Introduction

SAR is related to the rate at which energy is absorbed per unit mass in an object exposed to a radio field. The SAR distribution in a biological body is complicated and is usually carried out by experimental techniques or numerical modeling. The standard recommends limits for two tiers of groups, occupational/controlled and general population/uncontrolled, based on a person's awareness and ability to exercise control over his or her exposure. In general, occupational/controlled exposure limits are higher than the limits for general population/uncontrolled.

6.2 SAR Definition

The SAR definition is the time derivative (rate) of the incremental energy (dW) absorbed by (dissipated in) an incremental mass (dm) contained in a volume element (dv) of a given density (ρ). The equation description is as below:

$$SAR = \frac{d}{dt} \left(\frac{dW}{dm} \right) = \frac{d}{dt} \left(\frac{dW}{\rho dv} \right)$$

SAR is expressed in units of Watts per kilogram (W/kg)

SAR measurement can be either related to the temperature elevation in tissue by

$$SAR = c \left(\frac{\delta T}{\delta t} \right)$$

Where: C is the specific heat capacity, δT is the temperature rise and δt is the exposure duration, or related to the electrical field in the tissue by

$$SAR = \frac{\sigma |E|^2}{\rho}$$

Where: σ is the conductivity of the tissue, ρ is the mass density of tissue and E is the RMS electrical field strength.

However for evaluating SAR of low power transmitter, electrical field measurement is typically applied.

7 Tissue Simulating Liquids

7.1 Targets for tissue simulating liquid

Table 7.1: Targets for tissue simulating liquid

Frequency (MHz)	Liquid Type	Conductivity (σ)	$\pm 5\%$ Range	Permittivity (ϵ)	$\pm 5\%$ Range
835	Head	0.90	0.86~0.95	41.5	39.4~43.6
835	Body	0.97	0.92~1.02	55.2	52.4~58.0
1750	Head	1.37	1.30~1.44	40.08	38.1~42.1
1750	Body	1.49	1.42~1.56	53.4	50.7~56.1
1900	Head	1.40	1.33~1.47	40.0	38.0~42.0
1900	Body	1.52	1.44~1.60	53.3	50.6~56.0
2450	Head	1.80	1.71~1.89	39.2	37.2~41.2
2450	Body	1.95	1.85~2.05	52.7	50.1~55.3
5200	Head	4.66	4.43~4.89	35.99	34.19~37.79
5200	Body	5.30	5.04~5.56	49.0	46.6~51.4
5500	Head	4.96	4.71~5.21	35.64	33.86~37.42
5500	Body	5.65	5.37~5.93	48.6	46.2~51.0
5800	Head	5.27	5.01~5.53	35.3	33.5~37.1
5800	Body	6.00	5.70~6.30	48.2	45.8~50.6

7.2 Dielectric Performance

Table 7.2: Dielectric Performance of Tissue Simulating Liquid

Measurement Date (yyyy-mm-dd)	Type	Frequency	Permittivity ϵ	Drift (%)	Conductivity σ (S/m)	Drift (%)
2013-03-16	Head	835 MHz	40.73	-1.86	0.887	-1.44
	Body	835 MHz	56.42	2.21	0.983	1.34
2013-03-19	Head	1750 MHz	39.35	-1.82	1.382	0.88
	Body	1750 MHz	54.59	2.23	1.527	2.48
2013-03-17	Head	1900 MHz	39.63	-0.92	1.426	1.86
	Body	1900 MHz	52.64	-1.24	1.531	0.72
2013-03-26	Head	2450 MHz	39.78	1.48	1.813	0.72
	Body	2450 MHz	51.86	-1.59	1.962	0.62
2013-03-27	Head	5800 MHz	34.67	-1.78	5.335	1.23
	Body	5800 MHz	46.91	-2.68	6.138	2.30
2013-05-25	Head	5200 MHz	35.57	-1.17	4.558	-2.19
	Body	5200 MHz	48.24	-1.55	5.167	-2.51
2013-05-25	Head	5500 MHz	34.93	-1.99	4.956	-0.08
	Body	5500 MHz	47.59	-2.08	5.639	-0.19

Note: The liquid temperature is 22.0°C

Table 7.3: Dielectric Performance of Tissue Simulating Liquid for IC standard

Measurement Date (yyyy-mm-dd)	Type	Frequency	Permittivity ϵ	Drift (%)	Conductivity σ (S/m)	Drift (%)
2013-03-16	GSM850 Head	848.8 MHz	0.899	-0.11	40.568	-2.25
		836.6 MHz	0.886	-1.56	40.735	-1.84
		825 MHz	0.876	-2.67	40.897	-1.45
	WCDMA850 Head	846.6 MHz	0.897	-0.33	40.593	-2.19
		836.4 MHz	0.886	-1.56	40.735	-1.84
		826.4 MHz	0.878	-2.44	40.875	-1.51
	LTE Band5 Head	836.5 MHz	0.886	-1.56	40.735	-1.84
	GSM850 Body	848.8 MHz	0.998	2.89	56.25	1.90
		836.6 MHz	0.987	1.75	56.403	2.18
		825 MHz	0.975	0.52	56.535	2.42
	WCDMA850 Body	846.6 MHz	0.995	2.58	56.277	1.95
		836.4 MHz	0.987	1.75	56.403	2.18
826.4 MHz		0.975	0.52	56.517	2.39	
LTE Band5 Body	836.5 MHz	0.987	1.75	56.403	2.18	
2013-03-19	LTE Band4 Head	1732.5 MHz	1.365	-0.36	39.398	-1.70
	LTE Band4 Body	1745 MHz	1.523	2.21	54.601	2.25
		1732.5 MHz	1.513	1.54	54.644	2.33
		1720 MHz	1.503	0.87	54.675	2.39
2013-03-17	GSM1900 Head	1910 MHz	1.429	2.07	39.586	-1.04
		1880 MHz	1.41	0.71	39.638	-0.91
		1850.2 MHz	1.378	-1.57	39.757	-0.61
	WCDMA1900 Head	1907.6 MHz	1.428	2.00	39.597	-1.01
		1880 MHz	1.41	0.71	39.638	-0.91
		1852.4 MHz	1.379	-1.50	39.745	-0.64
	LTE Band2 Head	1880 MHz	1.41	0.71	39.638	-0.91
		1860 MHz	1.384	-1.14	39.703	-0.74
	GSM1900 Body	1910 MHz	1.544	1.58	52.627	-1.26
		1880 MHz	1.506	-0.92	52.683	-1.16
		1850.2 MHz	1.483	-2.43	52.851	-0.84
	WCDMA1900 Body	1907.6 MHz	1.541	1.38	52.632	-1.25
		1880 MHz	1.506	-0.92	52.683	-1.16
		1852.4 MHz	1.484	-2.37	52.841	-0.86
	LTE Band2 Body	1900 MHz	1.531	0.72	52.64	-1.24
1880 MHz		1.506	-0.92	52.683	-1.16	
1860 MHz		1.489	-2.04	52.797	-0.94	

2013-03-26	WiFi-2.4G Head	2462 MHz	1.826	1.44	39.728	1.35
		2437 MHz	1.8	0.00	39.842	1.64
		2412 MHz	1.773	-1.50	39.928	1.86
	WiFi-2.4G Body	2462 MHz	1.976	1.33	51.814	-1.68
		2437 MHz	1.948	-0.10	51.907	-1.50
		2412 MHz	1.92	-1.54	51.96	-1.40
2013-03-27	WiFi-5G Head	5745 MHz	5.262	-0.15	34.78	-1.47
		5765 MHz	5.289	0.36	34.754	-1.55
	WiFi-5G Body	5745 MHz	6.04	0.67	47.014	-2.46
		5765 MHz	6.076	1.27	46.984	-2.52
2013-05-25	WiFi-5G Head	5180 MHz	4.535	-2.68	35.62	-1.03
		5200 MHz	4.558	-2.19	35.57	-1.17
		5260 MHz	4.638	-0.47	35.44	-1.53
		5540 MHz	5.007	0.95	34.84	-2.24
		5580 MHz	5.059	2.00	34.76	-2.47
	WiFi-5G Body	5180 MHz	5.142	-2.98	48.30	-1.43
		5200 MHz	5.167	-2.51	48.24	-1.55
		5260 MHz	5.261	-0.74	48.11	-1.82
		5540 MHz	5.699	0.87	47.50	-2.26
		5580 MHz	5.762	1.98	47.41	-2.45

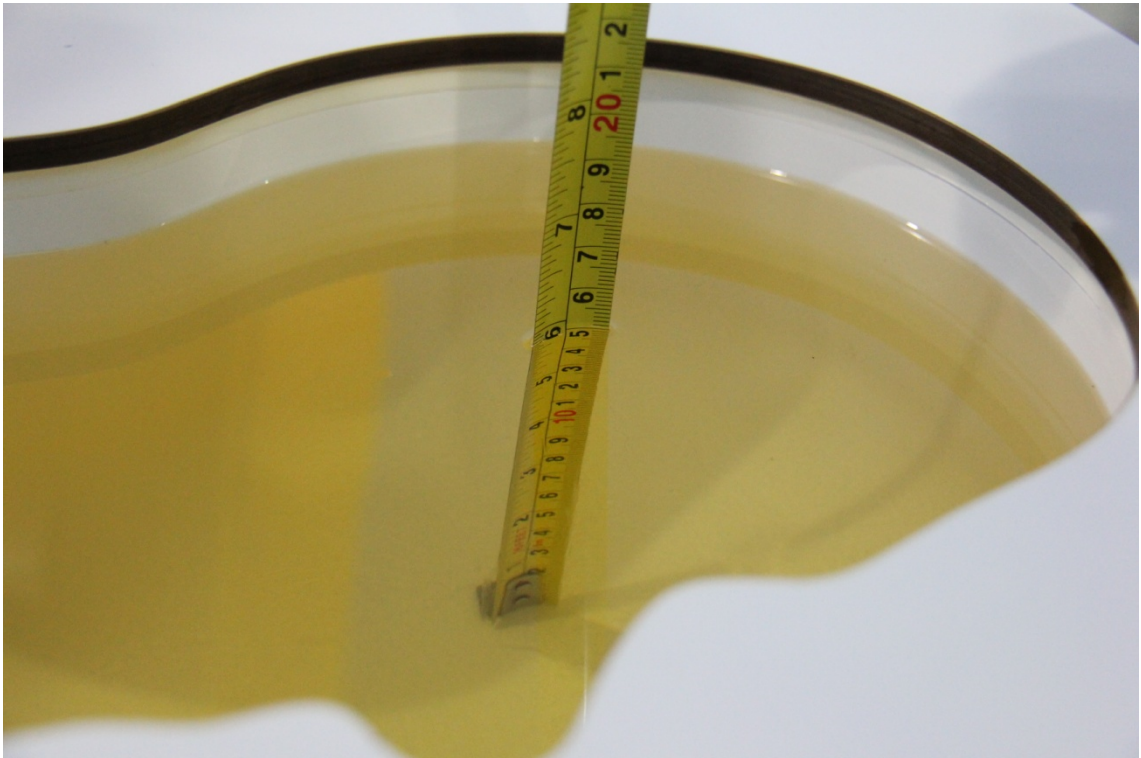

Picture 7-1: Liquid depth in the Head Phantom (835 MHz)

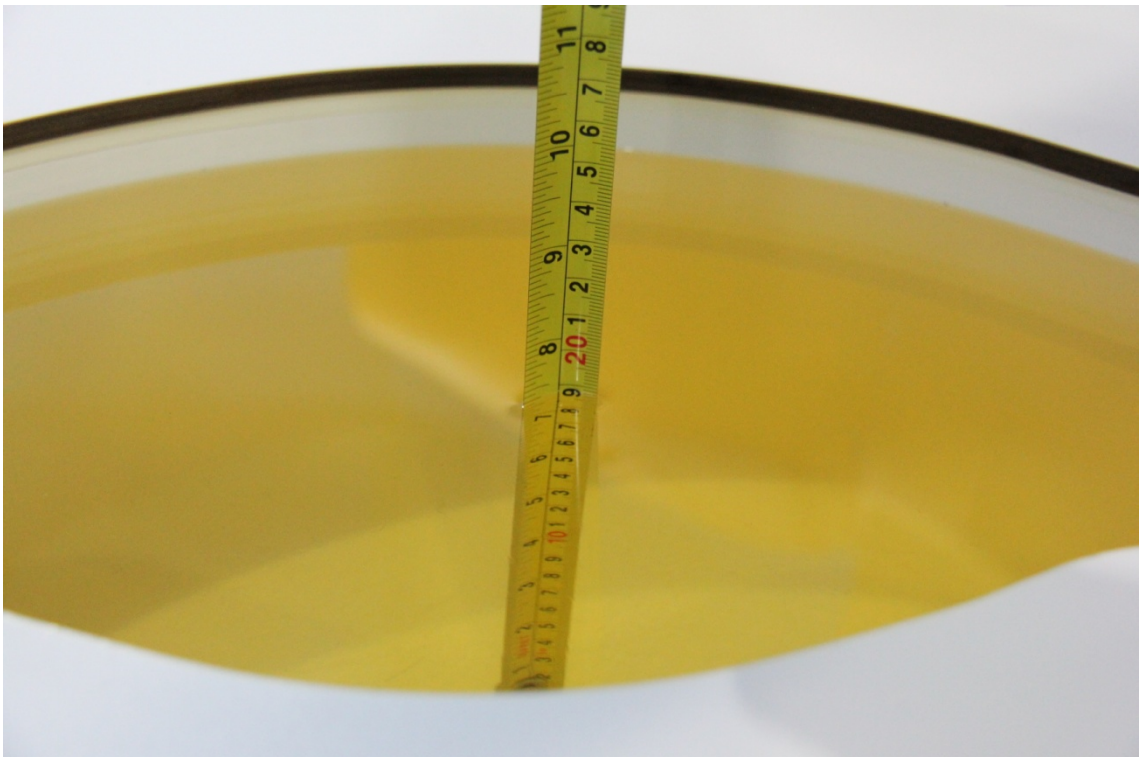

Picture 7-2: Liquid depth in the Flat Phantom (835 MHz)

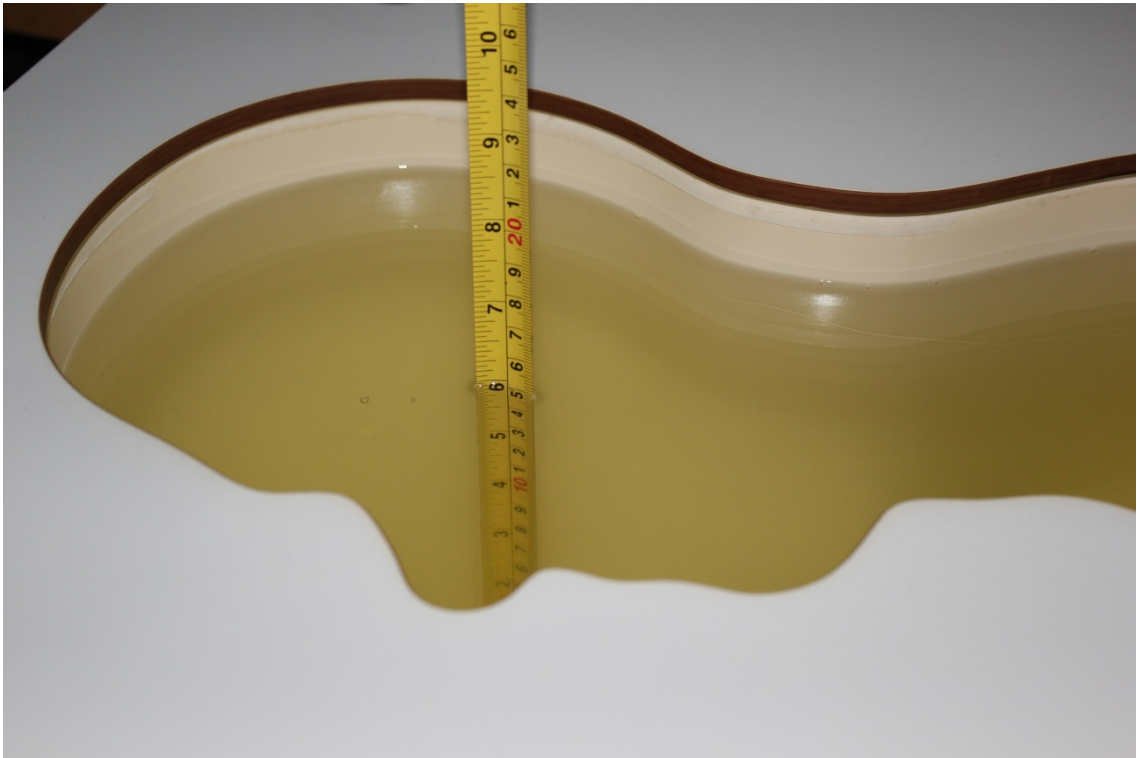

Picture 7-3: Liquid depth in the Head Phantom (1750 MHz)

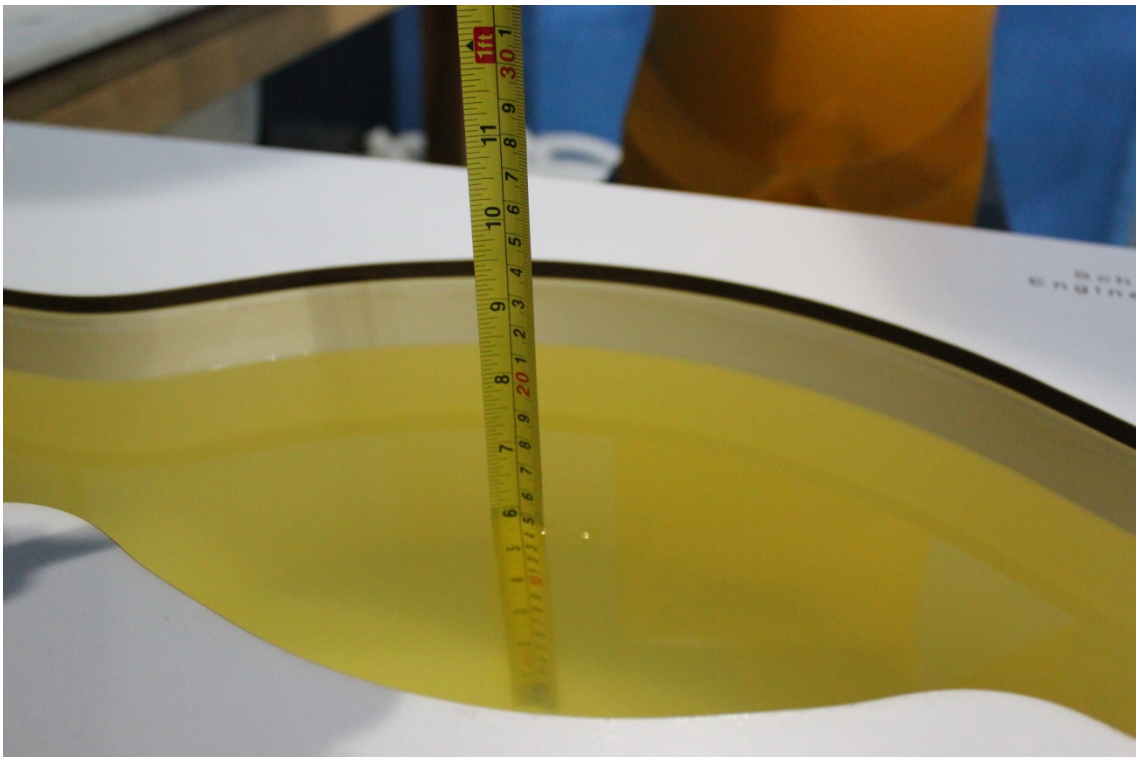

Picture 7-4 Liquid depth in the Flat Phantom (1750MHz)

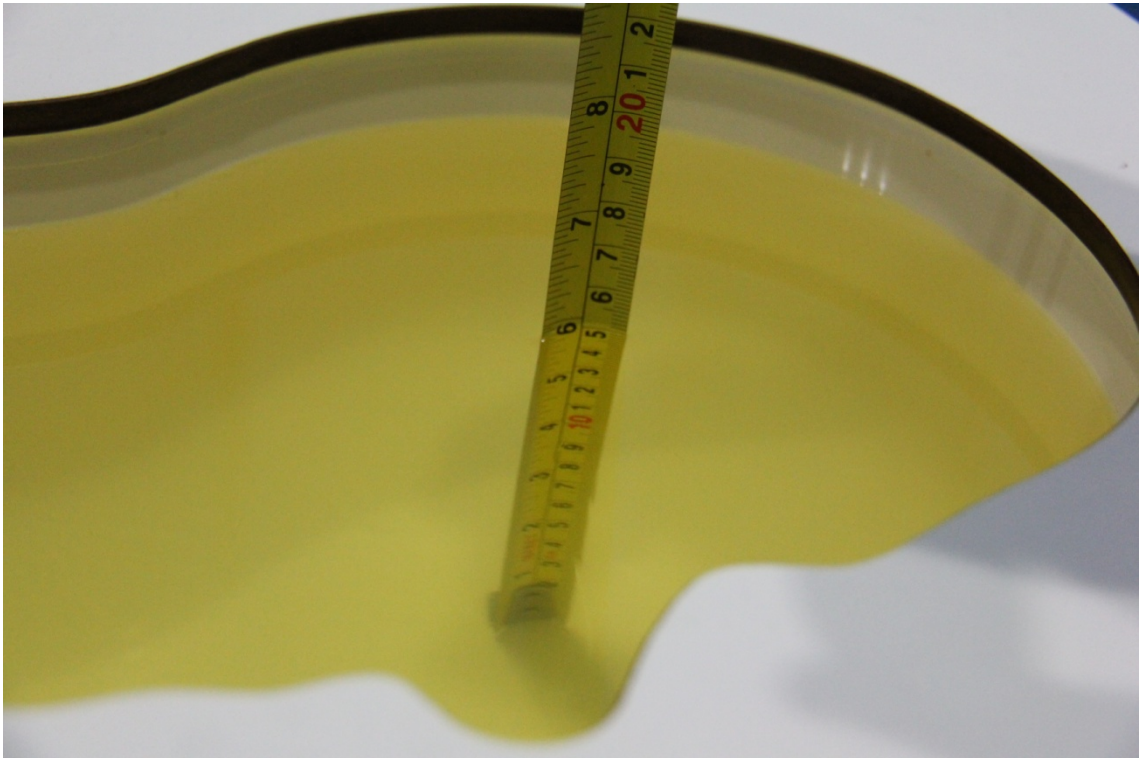

Picture 7-5: Liquid depth in the Head Phantom (1900 MHz)

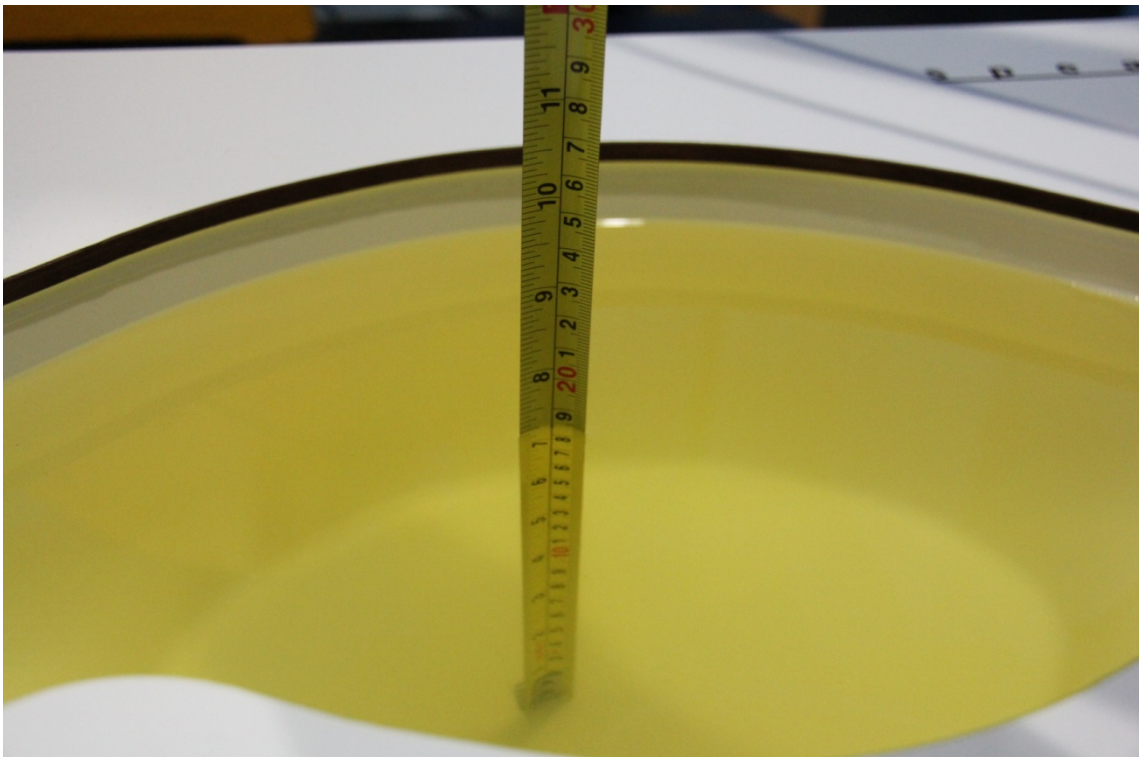

Picture 7-6 Liquid depth in the Flat Phantom (1900MHz)

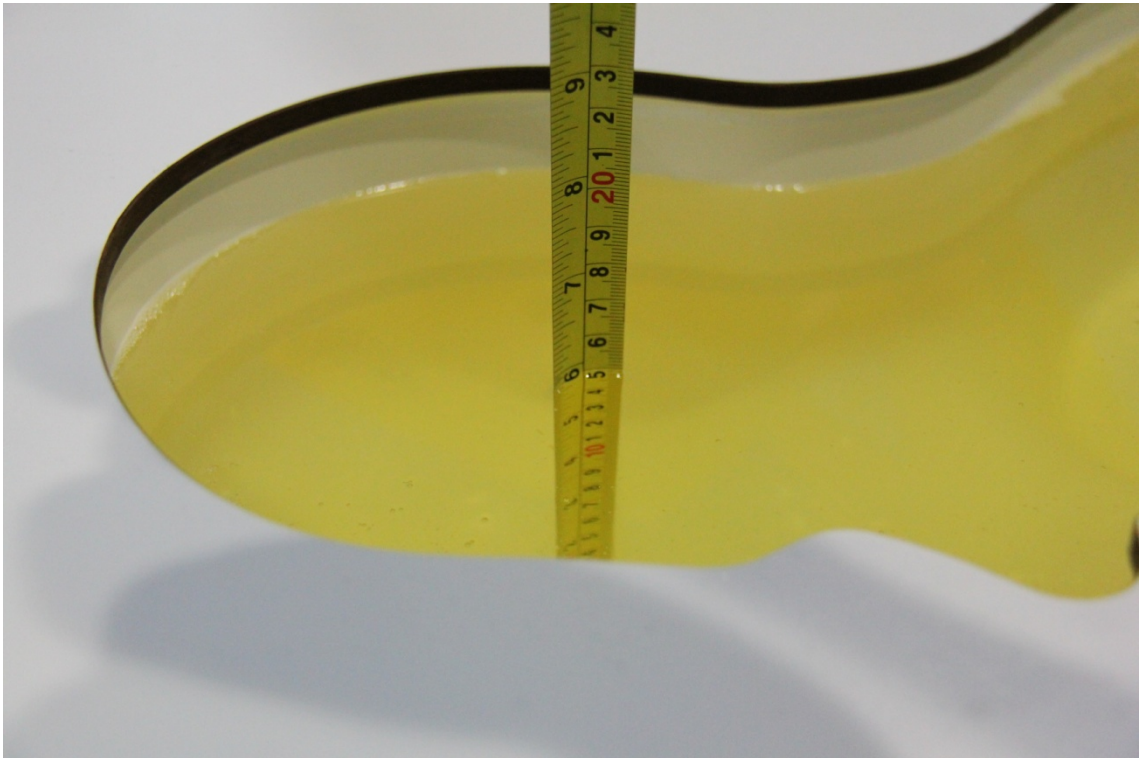

Picture 7-7 Liquid depth in the Head Phantom (2450MHz)

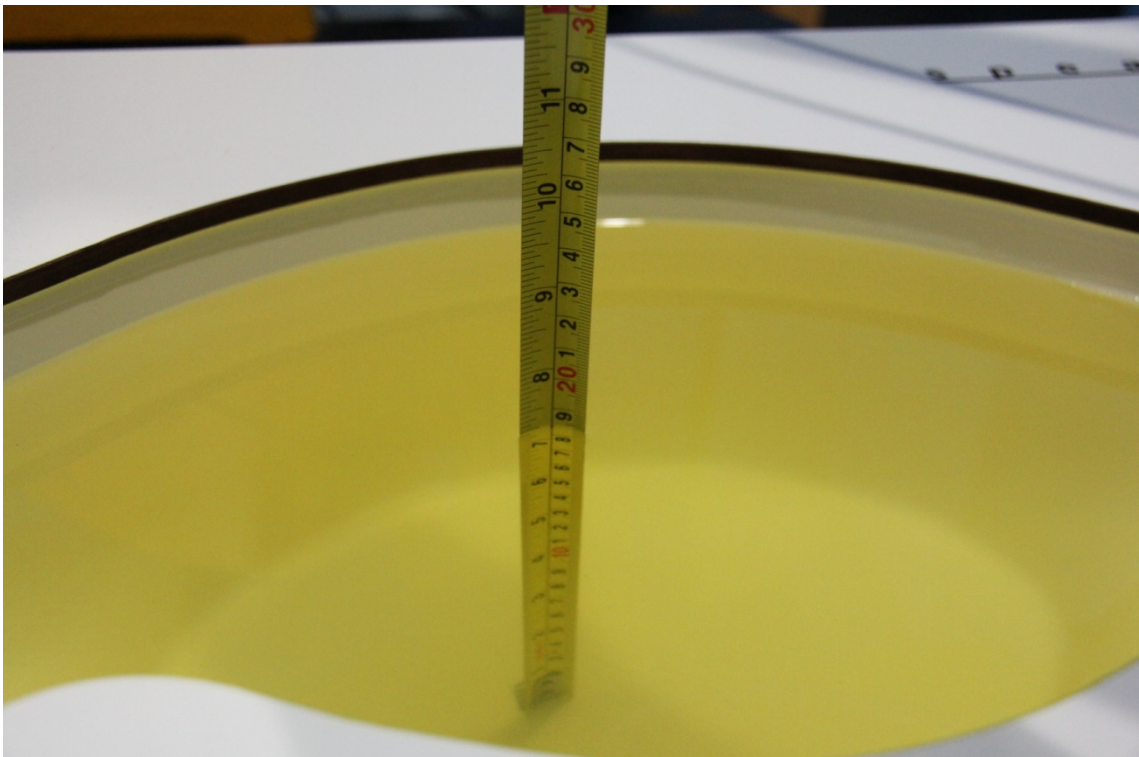

Picture 7-8 Liquid depth in the Flat Phantom (2450MHz)

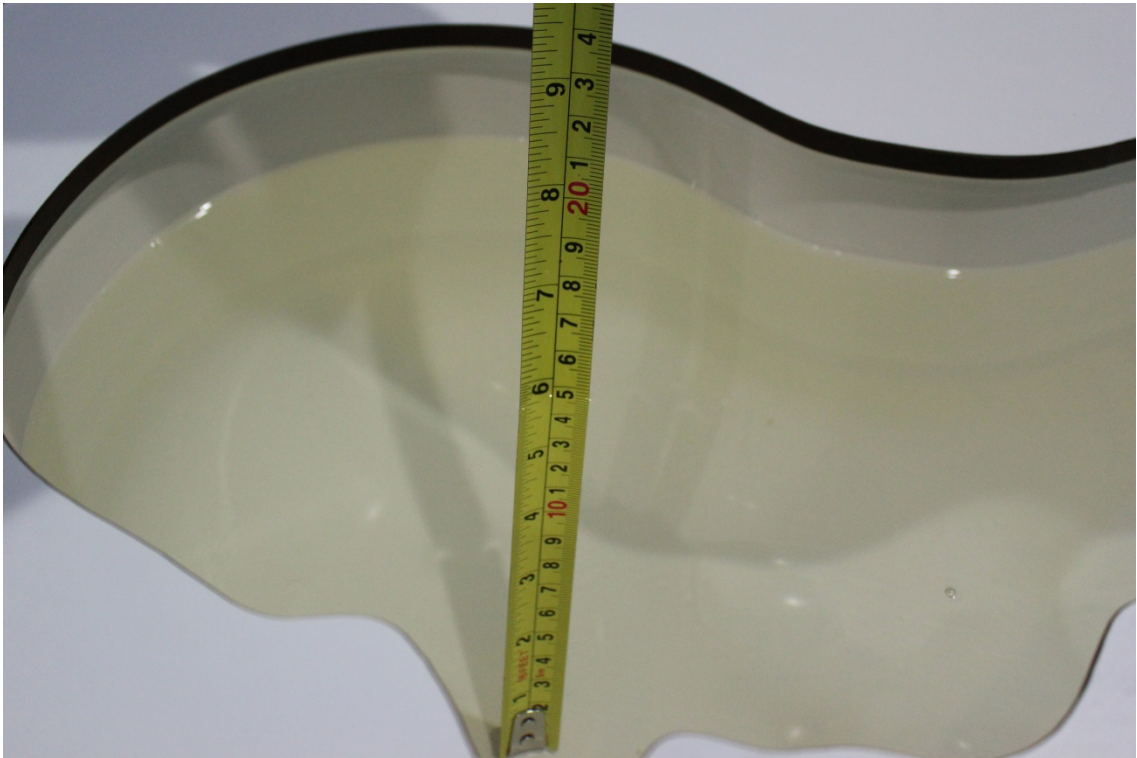

Picture 7-9 Liquid depth in the Head Phantom (5800MHz)

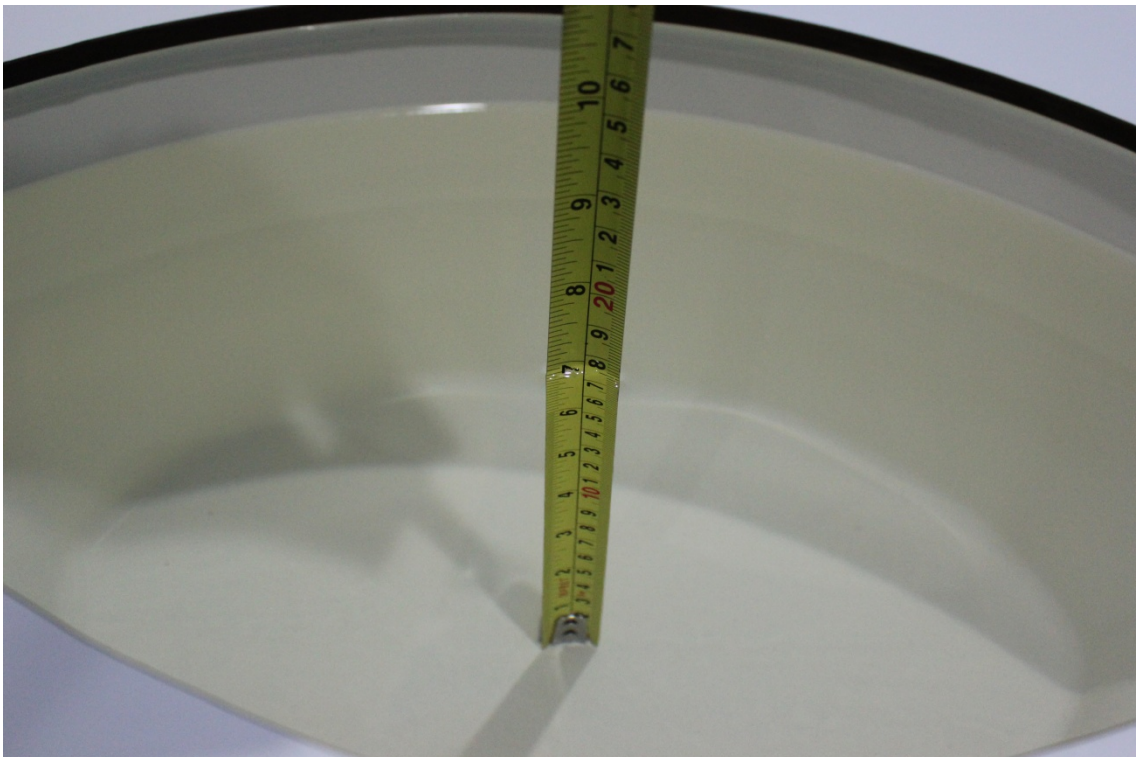

Picture 7-10 Liquid depth in the Flat Phantom (5800MHz)

8 System verification

8.1 System Setup

In the simplified setup for system evaluation, the DUT is replaced by a calibrated dipole and the power source is replaced by a continuous wave that comes from a signal generator. The calibrated dipole must be placed beneath the flat phantom section of the SAM twin phantom with the correct distance holder. The distance holder should touch the phantom surface with a light pressure at the reference marking and be oriented parallel to the long side of the phantom. The equipment setup is shown below:

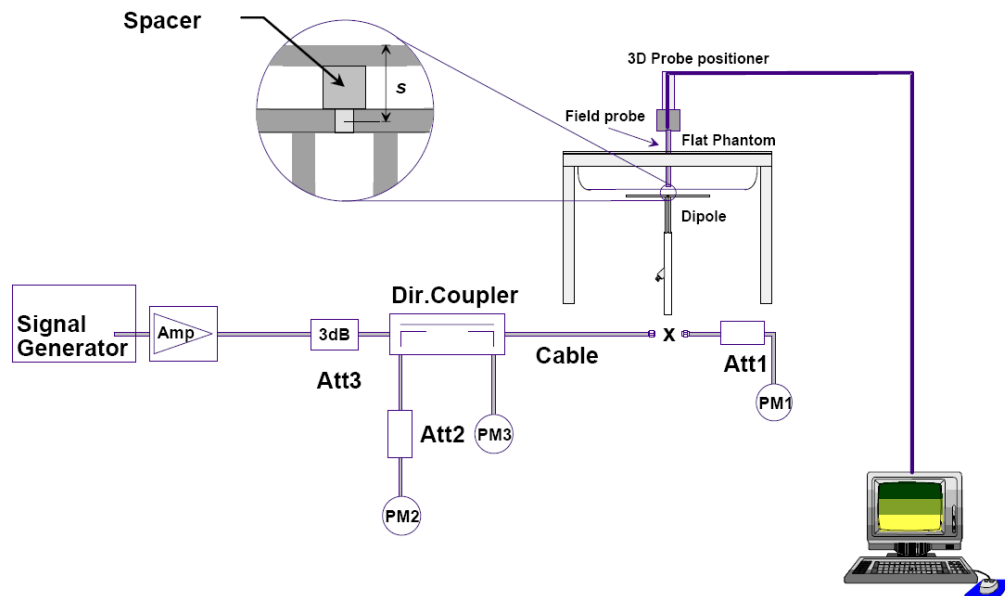

Picture 8.1 System Setup for System Evaluation

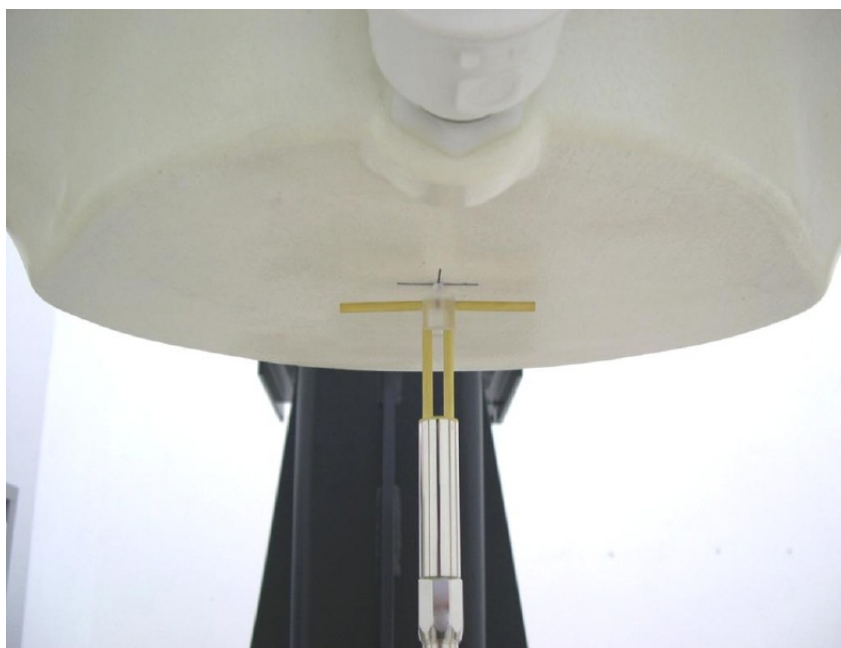

Picture 8.2 Photo of Dipole Setup

8.2 System Verification

SAR system verification is required to confirm measurement accuracy, according to the tissue dielectric media, probe calibration points and other system operating parameters required for measuring the SAR of a test device. The system verification must be performed for each frequency band and within the valid range of each probe calibration point required for testing the device.

The system verification results are required that the area scan estimated 1-g SAR is within 3% of the zoom scan 1-g SAR. The details are presented in annex B.

Table 8.1: System Verification of Head

Measurement Date (yyyy-mm-dd)	Frequency	Target value (W/kg)		Measured value (W/kg)		Deviation	
		10 g Average	1 g Average	10 g Average	1 g Average	10 g Average	1 g Average
2013-03-16	835 MHz	6.07	9.30	6.16	9.48	1.48%	1.94%
2013-03-19	1750 MHz	19.3	36.2	19.84	37.00	2.80%	2.21%
2013-03-17	1900 MHz	20.6	39.1	20.16	38.40	-2.14%	-1.79%
2013-03-26	2450 MHz	24.4	52.4	23.84	51.20	-2.30%	-2.29%
2013-03-27	5800 MHz	23.3	81.6	23.10	80.90	-0.86%	-0.86%
2013-05-25	5200 MHz	23.4	81.5	24.00	82.70	2.56%	1.47%
2013-05-26	5500 MHz	25.0	87.5	24.80	87.50	-0.80%	0.00%

Table 8.2: System Verification of Body

Measurement Date (yyyy-mm-dd)	Frequency	Target value (W/kg)		Measured value (W/kg)		Deviation	
		10 g Average	1 g Average	10 g Average	1 g Average	10 g Average	1 g Average
2013-03-16	835 MHz	6.20	9.36	6.44	9.68	3.87%	3.42%
2013-03-19	1750 MHz	20.1	37.4	19.72	36.36	-1.89%	-2.78%
2013-03-17	1900 MHz	21.3	39.9	21.80	40.80	2.35%	2.26%
2013-03-26	2450 MHz	23.6	50.4	24.28	51.60	2.88%	2.38%
2013-03-27	5800 MHz	20.4	73.8	20.40	73.20	0.00%	-0.81%
2013-05-25	5200 MHz	20.5	73.1	20.10	73.20	-1.95%	0.14%
2013-05-26	5500 MHz	21.7	78.1	21.50	77.60	-0.92%	-0.64%

9 Measurement Procedures

9.1 Tests to be performed

In order to determine the highest value of the peak spatial-average SAR of a handset, all device positions, configurations and operational modes shall be tested for each frequency band according to steps 1 to 3 below. A flowchart of the test process is shown in picture 9.1.

Step 1: The tests described in 9.2 shall be performed at the channel that is closest to the centre of the transmit frequency band (f_c) for:

- a) all device positions (cheek and tilt, for both left and right sides of the SAM phantom, as described in annex D),
- b) all configurations for each device position in a), e.g., antenna extended and retracted, and
- c) all operational modes, e.g., analogue and digital, for each device position in a) and configuration in b) in each frequency band.

If more than three frequencies need to be tested according to 11.1 (i.e., $N_c > 3$), then all frequencies, configurations and modes shall be tested for all of the above test conditions.

Step 2: For the condition providing highest peak spatial-average SAR determined in Step 1, perform all tests described in 9.2 at all other test frequencies, i.e., lowest and highest frequencies. In addition, for all other conditions (device position, configuration and operational mode) where the peak spatial-average SAR value determined in Step 1 is within 3 dB of the applicable SAR limit, it is recommended that all other test frequencies shall be tested as well.

Step 3: Examine all data to determine the highest value of the peak spatial-average SAR found in Steps 1 to 2.

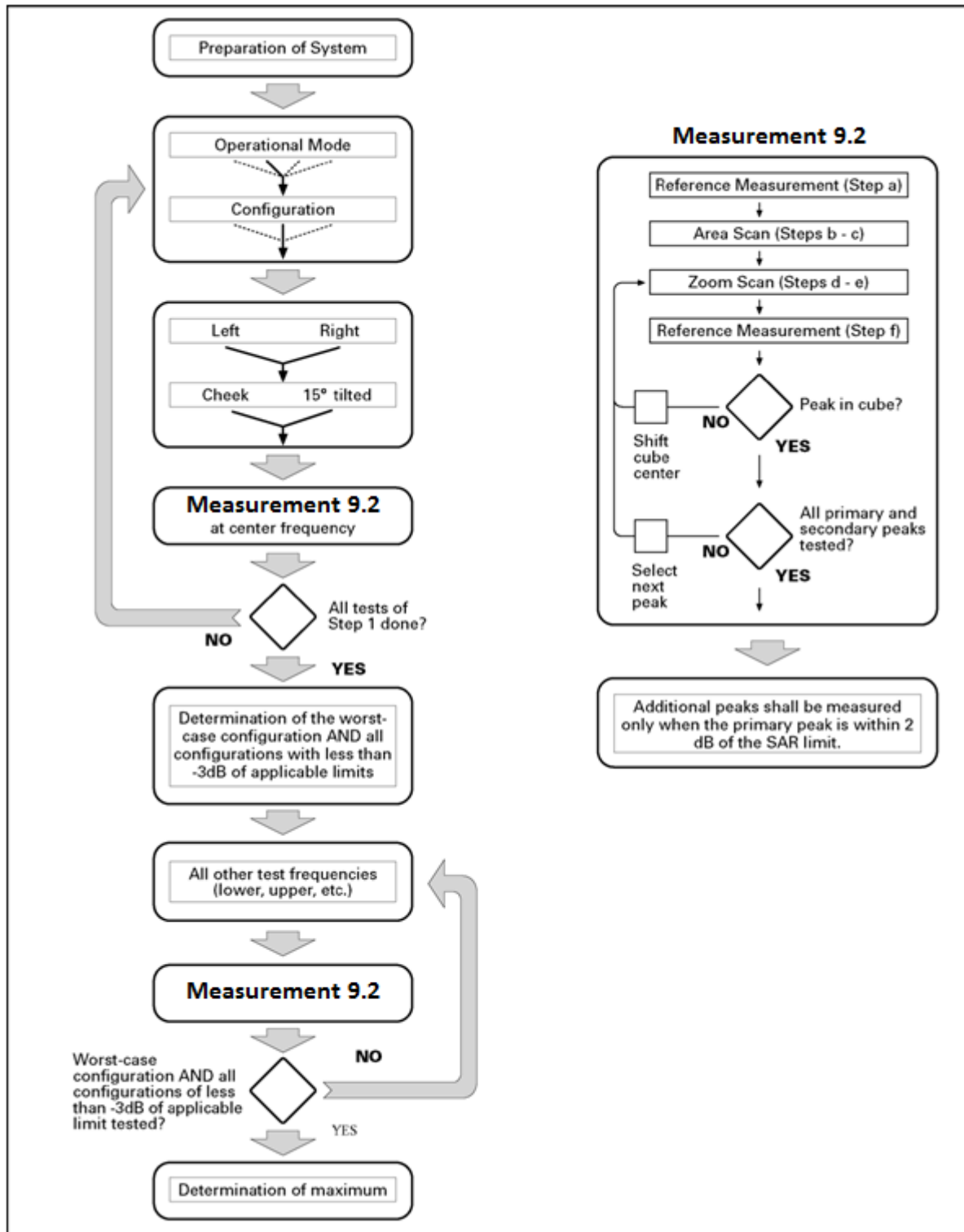

Picture 9.1 Block diagram of the tests to be performed

9.2 General Measurement Procedure

The area and zoom scan resolutions specified in the table below must be applied to the SAR measurements and fully documented in SAR reports to qualify for TCB approval. Probe boundary effect error compensation is required for measurements with the probe tip closer than half a probe tip diameter to the phantom surface. Both the probe tip diameter and sensor offset distance must satisfy measurement protocols; to ensure probe boundary effect errors are minimized and the higher fields closest to the phantom surface can be correctly measured and extrapolated to the phantom surface for computing 1-g SAR. Tolerances of the post-processing algorithms must be verified by the test laboratory for the scan resolutions used in the SAR measurements, according to the reference distribution functions specified in IEEE Std 1528-2003. The results should be documented as part of the system validation records and may be requested to support test results when all the measurement parameters in the following table are not satisfied.

		≤ 3 GHz	> 3 GHz	
Maximum distance from closest measurement point (geometric center of probe sensors) to phantom surface		5 ± 1 mm	$\frac{1}{2} \cdot \delta \cdot \ln(2) \pm 0.5$ mm	
Maximum probe angle from probe axis to phantom surface normal at the measurement location		$30^\circ \pm 1^\circ$	$20^\circ \pm 1^\circ$	
Maximum area scan spatial resolution: $\Delta x_{Area}, \Delta y_{Area}$		≤ 2 GHz: ≤ 15 mm 2 – 3 GHz: ≤ 12 mm	3 – 4 GHz: ≤ 12 mm 4 – 6 GHz: ≤ 10 mm	
		When the x or y dimension of the test device, in the measurement plane orientation, is smaller than the above, the measurement resolution must be \leq the corresponding x or y dimension of the test device with at least one measurement point on the test device.		
Maximum zoom scan spatial resolution: $\Delta x_{Zoom}, \Delta y_{Zoom}$		≤ 2 GHz: ≤ 8 mm 2 – 3 GHz: ≤ 5 mm*	3 – 4 GHz: ≤ 5 mm* 4 – 6 GHz: ≤ 4 mm*	
Maximum zoom scan spatial resolution, normal to phantom surface	uniform grid: $\Delta z_{Zoom}(n)$	≤ 5 mm	3 – 4 GHz: ≤ 4 mm 4 – 5 GHz: ≤ 3 mm 5 – 6 GHz: ≤ 2 mm	
	graded grid	$\Delta z_{Zoom}(1)$: between 1 st two points closest to phantom surface	≤ 4 mm	3 – 4 GHz: ≤ 3 mm 4 – 5 GHz: ≤ 2.5 mm 5 – 6 GHz: ≤ 2 mm
		$\Delta z_{Zoom}(n>1)$: between subsequent points	$\leq 1.5 \cdot \Delta z_{Zoom}(n-1)$	
Minimum zoom scan volume	x, y, z	≥ 30 mm	3 – 4 GHz: ≥ 28 mm 4 – 5 GHz: ≥ 25 mm 5 – 6 GHz: ≥ 22 mm	
<p>Note: δ is the penetration depth of a plane-wave at normal incidence to the tissue medium; see draft standard IEEE P1528-2011 for details.</p> <p>* When zoom scan is required and the <i>reported</i> SAR from the area scan based 1-g SAR estimation procedures of KDB 447498 is ≤ 1.4 W/kg, ≤ 8 mm, ≤ 7 mm and ≤ 5 mm zoom scan resolution may be applied, respectively, for 2 GHz to 3 GHz, 3 GHz to 4 GHz and 4 GHz to 6 GHz.</p>				

9.3 WCDMA Measurement Procedures for SAR

The following procedures are applicable to WCDMA handsets operating under 3GPP Release99, Release 5 and Release 6. The default test configuration is to measure SAR with an established radio link between the DUT and a communication test set using a 12.2kbps RMC (reference measurement channel) configured in Test Loop Mode 1. SAR is selectively confirmed for other physical channel configurations (DPCCH & DPDCH_n), HSDPA and HSPA (HSUPA/HSDPA) modes according to output power, exposure conditions and device operating capabilities. Both uplink and downlink should be configured with the same RMC or AMR, when required. SAR for Release 5 HSDPA and Release 6 HSPA are measured using the applicable FRC (fixed reference channel) and E-DCH reference channel configurations. Maximum output power is verified according to applicable versions of 3GPP TS 34.121 and SAR must be measured according to these maximum output conditions. When Maximum Power Reduction (MPR) is not implemented according to Cubic Metric (CM) requirements for Release 6 HSPA, the following procedures do not apply.

For Release 5 HSDPA Data Devices:

Sub-test	β_c	β_d	β_d (SF)	β_c / β_d	β_{hs}	CM/dB
1	2/15	15/15	64	2/15	4/15	0.0
2	12/15	15/15	64	12/15	24/25	1.0
3	15/15	8/15	64	15/8	30/15	1.5
4	15/15	4/15	64	15/4	30/15	1.5

For Release 6 HSPA Data Devices

Sub-test	β_c	β_d	β_d (SF)	β_c / β_d	β_{hs}	β_{ec}	β_{ed}	β_{ed} (SF)	β_{ed} (codes)	CM (dB)	MPR (dB)	AG Index	E-TFCI
1	11/15	15/15	64	11/15	22/15	209/225	1039/225	4	1	1.0	0.0	20	75
2	6/15	15/15	64	6/15	12/15	12/15	12/15	4	1	3.0	2.0	12	67
3	15/15	9/15	64	15/9	30/15	30/15	$\beta_{ed1}:47/15$ $\beta_{ed2}:47/15$	4	2	2.0	1.0	15	92
4	2/15	15/15	64	2/15	4/15	4/15	56/75	4	1	3.0	2.0	17	71
5	15/15	15/15	64	15/15	24/15	30/15	134/15	4	1	1.0	0.0	21	81

Rel.8 DC-HSDPA (Cat 24)

SAR test exclusion for Rel.8 DC-HSDPA must satisfy the SAR test exclusion requirements of Rel.5 HSDPA. SAR test exclusion for DC-HSDPA devices is determined by power measurements according to the H-Set 12, Fixed Reference Channel (FRC) configuration in Table C.8.1.12 of 3GPP TS 34.121-1. A primary and a secondary serving HS-DSCH Cell are required to perform the power measurement and for the results to qualify for SAR test exclusion.

9.4 SAR Measurement for LTE

SAR tests for LTE are performed with a base station simulator, Rohde & Schwarz CMW500. Closed loop power control was used so the UE transmits with maximum output power during SAR testing. All powers were measured with the CMW 500.

It is performed for conducted power and SAR based on the KDB941225 D05.

9.5 Bluetooth & Wi-Fi Measurement Procedures for SAR

Normal network operating configurations are not suitable for measuring the SAR of 802.11 transmitters in general. Unpredictable fluctuations in network traffic and antenna diversity conditions can introduce undesirable variations in SAR results. The SAR for these devices should be measured using chipset based test mode software to ensure that the results are consistent and reliable.

Chipset based test mode software is hardware dependent and generally varies among manufacturers. The device operating parameters established in a test mode for SAR measurements must be identical to those programmed in production units, including output power levels, amplifier gain settings and other RF performance tuning parameters. The test frequencies should correspond to actual channel frequencies defined for domestic use. SAR for devices with switched diversity should be measured with only one antenna transmitting at a time during each SAR measurement, according to a fixed modulation and data rate. The same data pattern should be used for all measurements.

In order to testing the conducted power of WLAN, the DUT is controlled to transmit WLAN TX as maximum power by the terminal software installed on the PC. The procedure how to control is presented as below:

1. Connect DUT and PC via the USB cable and check the port is opened.
2. Input the command "WLPU" to power on WLAN.
3. Input the command "WTFD" to firmware download.
4. Input the WBTX command to start transmit (i.e., WBTX=1,0,1,1500,25,0,12).
5. Input the command "WIDL" to stop transmit.
6. Input the command "WLPD" to power off WLAN.

9.6 Power Drift

To control the output power stability during the SAR test, DASY4 system calculates the power drift by measuring the E-field at the same location at the beginning and at the end of the measurement for each test position. These drift values can be found in Table 14.2 to Table 14.49 labeled as: (Power Drift [dB]). This ensures that the power drift during one measurement is within 5%.

10 Area Scan Based 1-g SAR

10.1 Requirement of KDB

According to the KDB447498 D01 v05, when the implementation is based the specific polynomial fit algorithm as presented at the 29th Bioelectromagnetics Society meeting (2007) and the estimated 1-g SAR is ≤ 1.2 W/kg, a zoom scan measurement is not required provided it is also not needed for any other purpose; for example, if the peak SAR location required for simultaneous transmission SAR test exclusion can be determined accurately by the SAR system or manually to discriminate between distinctive peaks and scattered noisy SAR distributions from area scans.

There must not be any warning or alert messages due to various measurement concerns identified by the SAR system; for example, noise in measurements, peaks too close to scan boundary, peaks are too sharp, spatial resolution and uncertainty issues etc. The SAR system verification must also demonstrate that the area scan estimated 1-g SAR is within 3% of the zoom scan 1-g SAR (See Annex B). When all the SAR results for each exposure condition in a frequency band and wireless mode are based on estimated 1-g SAR, the 1-g SAR for the highest SAR configuration must be determined by a zoom scan.

10.2 Fast SAR Algorithms

The approach is based on the area scan measurement applying a frequency dependent attenuation parameter. This attenuation parameter was empirically determined by analyzing a large number of phones. The MOTOROLA FAST SAR was developed and validated by the MOTOROLA Research Group in Ft. Lauderdale.

In the initial study, an approximation algorithm based on Linear fit was developed. The accuracy of the algorithm has been demonstrated across a broad frequency range (136-2450 MHz) and for both 1- and 10-g averaged SAR using a sample of 264 SAR measurements from 55 wireless handsets. For the sample size studied, the root-mean-squared errors of the algorithm are 1.2% and 5.8% for 1- and 10-g averaged SAR, respectively. The paper describing the algorithm in detail is expected to be published in August 2004 within the Special Issue of Transactions on MTT.

In the second step, the same research group optimized the fitting algorithm to an Polynomial fit whereby the frequency validity was extended to cover the range 30-6000MHz. Details of this study can be found in the BEMS 2007 Proceedings.

Both algorithms are implemented in DASY software.

11 Conducted Output Power

When WiFi Hotspot mode is activated (AP ON), in all operating modes, the conducted output power will be reduced for GSM1900, WCDMA1900 and LTE Bnd2&4. When WiFi Hotspot mode is deactivated (AP OFF), the RF output power level return to their normal RF power level.

11.1 Manufacturing tolerance

When the hotspot mode is ON:

Table 11.1: GPRS and EGPRS

GSM 1900 GPRS (GMSK)				
Channel		810	661	512
1 Txslot	Target (dBm)	28	28	28
	Tolerance \pm (dB)	-1.0 ~ +1.0	-1.0 ~ +1.0	-1.0 ~ +1.0
2 Txslots	Target (dBm)	25	25	25
	Tolerance \pm (dB)	-1.0 ~ +1.0	-1.0 ~ +1.0	-1.0 ~ +1.0
3Txslots	Target (dBm)	23	23	23
	Tolerance \pm (dB)	-1.0 ~ +1.0	-1.0 ~ +1.0	-1.0 ~ +1.0
4 Txslots	Target (dBm)	22	22	22
	Tolerance \pm (dB)	-1.0 ~ +1.0	-1.0 ~ +1.0	-1.0 ~ +1.0
GSM 1900 EGPRS (GMSK)				
Channel		810	661	512
1 Txslot	Target (dBm)	28	28	28
	Tolerance \pm (dB)	-1.0 ~ +1.0	-1.0 ~ +1.0	-1.0 ~ +1.0
2 Txslots	Target (dBm)	25	25	25
	Tolerance \pm (dB)	-1.0 ~ +1.0	-1.0 ~ +1.0	-1.0 ~ +1.0
3Txslots	Target (dBm)	23	23	23
	Tolerance \pm (dB)	-1.0 ~ +1.0	-1.0 ~ +1.0	-1.0 ~ +1.0
4 Txslots	Target (dBm)	22	22	22
	Tolerance \pm (dB)	-1.0 ~ +1.0	-1.0 ~ +1.0	-1.0 ~ +1.0
GSM 1900 EGPRS (8PSK)				
Channel		810	661	512
1 Txslot	Target (dBm)	25	25	25
	Tolerance \pm (dB)	-2.0 ~ +1.0	-2.0 ~ +1.0	-2.0 ~ +1.0
2 Txslots	Target (dBm)	23	23	23
	Tolerance \pm (dB)	-2.0 ~ +1.0	-2.0 ~ +1.0	-2.0 ~ +1.0
3Txslots	Target (dBm)	22	22	22
	Tolerance \pm (dB)	-2.0 ~ +1.0	-2.0 ~ +1.0	-2.0 ~ +1.0
4 Txslots	Target (dBm)	21	21	21
	Tolerance \pm (dB)	-2.0 ~ +1.0	-2.0 ~ +1.0	-2.0 ~ +1.0

Table 11.2: WCDMA

WCDMA 1900 CS			
Channel	Channel 9538	Channel 9400	Channel 9262
Target (dBm)	18.8	18.8	18.8
Tolerance ±(dB)	-1.0 ~ +0.7	-1.0 ~ +0.7	-1.0 ~ +0.7

Table 11.3: LTE

Mode	Target (dBm)	Tolerance ±(dB)
LTE Band 2	18.8	-1.0 ~ +0.7
LTE Band 4	19	-1.0 ~ +1.0

LTE MPR will follow up 3GPP setting as below:

Modulation	Channel bandwidth / Transmission bandwidth (NRB)						MPR (dB)
	1.4MHz	3.0MHz	5MHz	10MHz	15MHz	20MHz	
QPSK	≤ 5	≤ 4	≤ 8	≤ 12	≤ 16	≤ 18	0
QPSK	> 5	> 4	> 8	> 12	> 16	> 18	0
16 QAM	≤ 5	≤ 4	≤ 8	≤ 12	≤ 16	≤ 18	0
16 QAM	> 5	> 4	> 8	> 12	> 16	> 18	0

Note: When the hotspot mode is ON, MPR settings doesn't work.

When the hotspot mode is OFF:

Table 11.4: GSM Speech

GSM 850			
Channel	Channel 251	Channel 190	Channel 128
Target (dBm)	33	33	33
Tolerance ±(dB)	-1.5 ~ +1.0	-1.5 ~ +1.0	-1.5 ~ +1.0
GSM 1900			
Channel	Channel 810	Channel 661	Channel 512
Target (dBm)	30	30	30
Tolerance ±(dB)	-1.5 ~ +1.0	-1.5 ~ +1.0	-1.5 ~ +1.0

Table 11.5: GPRS and EGPRS

GSM 850 GPRS (GMSK)				
Channel		251	190	128
1 Txslot	Target (dBm)	33	33	33
	Tolerance ±(dB)	-1.0 ~ +1.0	-1.0 ~ +1.0	-1.0 ~ +1.0
2 Txslots	Target (dBm)	30	30	30
	Tolerance ±(dB)	-1.0 ~ +1.0	-1.0 ~ +1.0	-1.0 ~ +1.0
3Txslots	Target (dBm)	28.5	28.5	28.5
	Tolerance ±(dB)	-1.0 ~ +1.0	-1.0 ~ +1.0	-1.0 ~ +1.0
4 Txslots	Target (dBm)	27.5	27.5	27.5
	Tolerance ±(dB)	-1.0 ~ +1.0	-1.0 ~ +1.0	-1.0 ~ +1.0

GSM 850 EGPRS (GMSK)				
Channel		251	190	128
1 Txslot	Target (dBm)	33	33	33
	Tolerance \pm (dB)	-1.0 ~ +1.0	-1.0 ~ +1.0	-1.0 ~ +1.0
2 Txslots	Target (dBm)	30	30	30
	Tolerance \pm (dB)	-1.0 ~ +1.0	-1.0 ~ +1.0	-1.0 ~ +1.0
3Txslots	Target (dBm)	28.5	28.5	28.5
	Tolerance \pm (dB)	-1.0 ~ +1.0	-1.0 ~ +1.0	-1.0 ~ +1.0
4 Txslots	Target (dBm)	27.5	27.5	27.5
	Tolerance \pm (dB)	-1.0 ~ +1.0	-1.0 ~ +1.0	-1.0 ~ +1.0
GSM 850 EGPRS (8PSK)				
Channel		251	190	128
1 Txslot	Target (dBm)	26.5	26.5	26.5
	Tolerance \pm (dB)	-2.0 ~ +1.0	-2.0 ~ +1.0	-2.0 ~ +1.0
2 Txslots	Target (dBm)	25.5	25.5	25.5
	Tolerance \pm (dB)	-2.0 ~ +1.0	-2.0 ~ +1.0	-2.0 ~ +1.0
3Txslots	Target (dBm)	24.5	24.5	24.5
	Tolerance \pm (dB)	-2.0 ~ +1.0	-2.0 ~ +1.0	-2.0 ~ +1.0
4 Txslots	Target (dBm)	23.5	23.5	23.5
	Tolerance \pm (dB)	-2.0 ~ +1.0	-2.0 ~ +1.0	-2.0 ~ +1.0
GSM 1900 GPRS (GMSK)				
Channel		810	661	512
1 Txslot	Target (dBm)	30	30	30
	Tolerance \pm (dB)	-1.0 ~ +1.0	-1.0 ~ +1.0	-1.0 ~ +1.0
2 Txslots	Target (dBm)	27	27	27
	Tolerance \pm (dB)	-1.0 ~ +1.0	-1.0 ~ +1.0	-1.0 ~ +1.0
3Txslots	Target (dBm)	25	25	25
	Tolerance \pm (dB)	-1.0 ~ +1.0	-1.0 ~ +1.0	-1.0 ~ +1.0
4 Txslots	Target (dBm)	23.8	23.8	23.8
	Tolerance \pm (dB)	-1.0 ~ +1.0	-1.0 ~ +1.0	-1.0 ~ +1.0
GSM 1900 EGPRS (GMSK)				
Channel		810	661	512
1 Txslot	Target (dBm)	30	30	30
	Tolerance \pm (dB)	-1.0 ~ +1.0	-1.0 ~ +1.0	-1.0 ~ +1.0
2 Txslots	Target (dBm)	27	27	27
	Tolerance \pm (dB)	-1.0 ~ +1.0	-1.0 ~ +1.0	-1.0 ~ +1.0
3Txslots	Target (dBm)	25	25	25
	Tolerance \pm (dB)	-1.0 ~ +1.0	-1.0 ~ +1.0	-1.0 ~ +1.0
4 Txslots	Target (dBm)	23.8	23.8	23.8
	Tolerance \pm (dB)	-1.0 ~ +1.0	-1.0 ~ +1.0	-1.0 ~ +1.0

GSM 1900 EGPRS (8PSK)				
Channel		810	661	512
1 Txslot	Target (dBm)	25.5	25.5	25.5
	Tolerance \pm (dB)	-2.0 ~ +1.0	-2.0 ~ +1.0	-2.0 ~ +1.0
2 Txslots	Target (dBm)	24.5	24.5	24.5
	Tolerance \pm (dB)	-2.0 ~ +1.0	-2.0 ~ +1.0	-2.0 ~ +1.0
3Txslots	Target (dBm)	23.5	23.5	23.5
	Tolerance \pm (dB)	-2.0 ~ +1.0	-2.0 ~ +1.0	-2.0 ~ +1.0
4 Txslots	Target (dBm)	22.5	22.5	22.5
	Tolerance \pm (dB)	-2.0 ~ +1.0	-2.0 ~ +1.0	-2.0 ~ +1.0

Table 11.6: WCDMA

WCDMA 850 CS				
Channel	Channel 4233	Channel 4182	Channel 4132	
Target (dBm)	24	24	24	
Tolerance \pm (dB)	-1.0 ~ +0.7	-1.0 ~ +0.7	-1.0 ~ +0.7	
HSDPA (sub-test 1/2/3/4)				
Channel	Channel 4233	Channel 4182	Channel 4132	
Target (dBm)	22	22	22	
Tolerance \pm (dB)	-1.0 ~ +1.0	-1.0 ~ +1.0	-1.0 ~ +1.0	
HSUPA (sub-test 1/5)				
Channel	Channel 4233	Channel 4182	Channel 4132	
Target (dBm)	23	23	23	
Tolerance \pm (dB)	-1.0 ~ +1.0	-1.0 ~ +1.0	-1.0 ~ +1.0	
HSUPA (sub-test 2/3/4)				
Channel	Channel 4233	Channel 4182	Channel 4132	
Target (dBm)	22	22	22	
Tolerance \pm (dB)	-1.0 ~ +1.0	-1.0 ~ +1.0	-1.0 ~ +1.0	
WCDMA 1900 CS				
Channel	Channel 9538	Channel 9400	Channel 9262	
Target (dBm)	23	23	23	
Tolerance \pm (dB)	-1.0 ~ +0.7	-1.0 ~ +0.7	-1.0 ~ +0.7	
HSDPA (sub-test 1/2/3/4)				
Channel	Channel 9538	Channel 9400	Channel 9262	
Target (dBm)	22	22	22	
Tolerance \pm (dB)	-1.0 ~ +1.0	-1.0 ~ +1.0	-1.0 ~ +1.0	
HSUPA (sub-test 1/5)				
Channel	Channel 9538	Channel 9400	Channel 9262	
Target (dBm)	22	22	22	
Tolerance \pm (dB)	-1.0 ~ +1.0	-1.0 ~ +1.0	-1.0 ~ +1.0	
HSUPA (sub-test 2/3/4)				
Channel	Channel 9538	Channel 9400	Channel 9262	
Target (dBm)	21	21	21	
Tolerance \pm (dB)	-1.0 ~ +1.0	-1.0 ~ +1.0	-1.0 ~ +1.0	

Table 11.7: LTE

Mode	Target (dBm)	Tolerance \pm (dB)
LTE Band 2	22.5	-1.0 ~ +0.7
LTE Band 4	23	-1.0 ~ +1.0
LTE Band 5	23	-1.0 ~ +1.0

LTE MPR will follow up 3GPP setting as below:

Modulation	Channel bandwidth / Transmission bandwidth (NRB)						MPR (dB)
	1.4MHz	3.0MHz	5MHz	10MHz	15MHz	20MHz	
QPSK	≤ 5	≤ 4	≤ 8	≤ 12	≤ 16	≤ 18	0
QPSK	> 5	> 4	> 8	> 12	> 16	> 18	1
16 QAM	≤ 5	≤ 4	≤ 8	≤ 12	≤ 16	≤ 18	1
16 QAM	> 5	> 4	> 8	> 12	> 16	> 18	2

Table 11.8: Bluetooth

Bluetooth			
Channel	Channel 0	Channel 39	Channel 78
Target (dBm)	4	4	4
Tolerance \pm (dB)	-7.0 ~ +7.0	-7.0 ~ +7.0	-7.0 ~ +7.0

Table 11.9: WiFi

Mode	Target (dBm)	Tolerance \pm (dB)
802.11 b	13	-3.0 ~ +3.0
802.11 g	12	-5.0 ~ +3.0
802.11 n (2.4GHz HT20)	11	-3.0 ~ +3.0
802.11 a	11	-3.0 ~ +2.0
802.11 n (5GHz HT20)	10	-3.0 ~ +3.0
802.11 n (5GHz HT40)	9	-3.0 ~ +3.0

11.2 GSM Measurement result

During the process of testing, the EUT was controlled via Agilent Digital Radio Communication tester (E5515C) to ensure the maximum power transmission and proper modulation. This result contains conducted output power for the EUT. In all cases, the measured peak output power should be greater and within 5% than EMI measurement.

Table 11.10: The conducted power measurement results for GSM850/1900

GSM 850MHz	Conducted Power (dBm)		
	Channel 251(848.8MHz)	Channel 190(836.6MHz)	Channel 128(824.2MHz)
	33.70	33.65	33.58
GSM 1900MHz	Conducted Power (dBm)		
	Channel 810(1909.8MHz)	Channel 661(1880MHz)	Channel 512(1850.2MHz)
	30.61	30.62	30.73

Table 11.11: The conducted power measurement results for GPRS and EGPRS

GSM 850 GPRS (GMSK)	Measured Power (dBm)			calculation	Averaged Power (dBm)		
	251	190	128		251	190	128
1 Txslot	33.70	33.68	33.57	-9.03dB	24.67	24.65	24.54

2 Txslots	30.11	29.81	30.07	-6.02dB	24.09	23.79	24.05
3Txslots	28.47	28.30	28.33	-4.26dB	24.21	24.04	24.07
4 Txslots	27.44	27.39	27.43	-3.01dB	24.43	24.38	24.42
GSM 850 EGPRS (GMSK)	Measured Power (dBm)			calculation	Averaged Power (dBm)		
	251	190	128		251	190	128
1 Txslot	33.74	33.66	33.60	-9.03dB	24.71	24.63	24.57
2 Txslots	30.13	29.92	30.05	-6.02dB	24.11	23.90	24.03
3Txslots	28.52	28.28	28.35	-4.26dB	24.26	24.02	24.09
4 Txslots	27.46	27.38	27.40	-3.01dB	24.45	24.37	24.39
GSM 850 EGPRS (8PSK)	Measured Power (dBm)			calculation	Averaged Power (dBm)		
	251	190	128		251	190	128
1 Txslot	26.75	26.66	26.70	-9.03dB	17.72	17.63	17.67
2 Txslots	25.13	25.04	25.09	-6.02dB	19.11	19.02	19.07
3Txslots	24.09	23.97	24.04	-4.26dB	19.83	19.71	19.78
4 Txslots	23.05	22.94	23.00	-3.01dB	20.04	19.93	19.99
PCS1900 GPRS (GMSK)	Measured Power (dBm)			calculation	Averaged Power (dBm)		
	810	661	512		810	661	512
1 Txslot	30.59	30.61	30.72	-9.03dB	21.56	21.58	21.69
2 Txslots	27.04	27.12	27.25	-6.02dB	21.02	21.10	21.23
3Txslots	25.01	25.19	25.30	-4.26dB	20.75	20.93	21.04
4 Txslots	23.78	23.84	24.05	-3.01dB	20.77	20.83	21.04
PCS1900 EGPRS (GMSK)	Measured Power (dBm)			calculation	Averaged Power (dBm)		
	810	661	512		810	661	512
1 Txslot	30.53	30.54	30.68	-9.03dB	21.50	21.51	21.65
2 Txslots	26.97	27.03	27.17	-6.02dB	20.95	21.01	21.15
3Txslots	24.93	25.11	25.25	-4.26dB	20.67	20.85	20.99
4 Txslots	23.70	23.75	23.98	-3.01dB	20.69	20.74	20.97
PCS1900 EGPRS (8PSK)	Measured Power (dBm)			calculation	Averaged Power (dBm)		
	810	661	512		810	661	512
1 Txslot	25.69	25.82	25.97	-9.03dB	16.66	16.79	16.94
2 Txslots	23.69	23.84	23.93	-6.02dB	17.67	17.82	17.91
3Txslots	22.65	22.81	22.92	-4.26dB	18.39	18.55	18.66
4 Txslots	21.60	21.73	21.86	-3.01dB	18.59	18.72	18.85

NOTES:

To average the power, the division factor is as follows:

1TX-slot = 1 transmit time slot out of 8 time slots=> conducted power divided by (8/1) => -9.03dB

2TX-slots = 2 transmit time slots out of 8 time slots=> conducted power divided by (8/2) => -6.02dB

3TX-slots = 3 transmit time slots out of 8 time slots=> conducted power divided by (8/3) => -4.26dB

4TX-slots = 4 transmit time slots out of 8 time slots=> conducted power divided by (8/4) => -3.01dB

According to the conducted power as above, the body measurements are performed with 1Txslots for GPRS and EGPRS.

Note: According to the KDB941225 D03, “when SAR tests for EDGE or EGPRS mode is necessary, GMSK modulation should be used”.

11.3 WCDMA Measurement result

Table 11.12: The conducted Power for WCDMA850/1900

Item	band	FDDV result		
	ARFCN	4233 (846.6MHz)	4182 (836.4MHz)	4132 (826.4MHz)
WCDMA	\	24.54	24.62	24.66
HSDPA	1	22.4	22.5	22.7
	2	22.4	22.5	22.6
	3	21.9	22.0	21.8
	4	21.9	22.1	22.1
HSUPA	1	22.35	22.02	22.07
	2	21.03	21.48	21.44
	3	21.40	21.67	21.64
	4	22.09	21.73	21.73
	5	22.60	22.78	22.81
DC-HSDPA (Cat 24)	1	22.66	22.70	22.73
	2	22.70	22.72	22.75
	3	22.69	22.72	22.73
	4	22.67	22.71	22.74
Item	band	FDDII result		
	ARFCN	9538 (1907.6MHz)	9400 (1880MHz)	9262 (1852.4MHz)
WCDMA	\	23.68	23.62	23.68
HSDPA	1	21.9	21.7	21.7
	2	22.1	21.8	21.8
	3	21.7	21.4	21.4
	4	21.5	21.4	21.5
HSUPA	1	21.79	21.60	21.85
	2	20.87	21.18	20.67
	3	21.29	20.83	20.26
	4	21.31	21.39	21.09
	5	22.30	22.15	22.02
DC-HSDPA (Cat 24)	1	21.81	21.88	21.78
	2	21.83	21.86	21.74
	3	21.80	21.84	21.77
	4	21.78	21.78	21.78

Note1: DC-HSDPA power measurements have been performed in accordance with methods agreed with the FCC via KDB inquiry.

Note2: HSDPA&HSUPA&DC-HSDPA body SAR for WCDMA850&1900 are not required, because maximum average output power of each RF channel with HSDPA&HSUPA&DC-HSDPA active is not 1/4 dB higher than that measured without HSDPA&HSUPA&DC-HSDPA.

11.4 LTE Measurement result

Table 11.13: The conducted Power for LTE

Band 2							
Bandwidth (MHz)	RB allocation	Frequency (MHz)	Max. Target Power (dBm)	QPSK		16QAM	
	RB offset (Start RB)			Actual output power (dBm)	MPR	Actual output power (dBm)	MPR
1.4 MHz	1RB High (5)	1909.3	23.2	22.61	0	21.84	1
		1880	23.2	22.84	0	21.90	1
		1850.7	23.2	22.81	0	22.20	1
	1RB Middle (3)	1909.3	23.2	22.65	0	21.71	1
		1880	23.2	22.72	0	21.99	1
		1850.7	23.2	22.77	0	21.81	1
	1RB Low (0)	1909.3	23.2	22.68	0	21.69	1
		1880	23.2	22.83	0	22.04	1
		1850.7	23.2	22.79	0	21.86	1
	3RB High (3)	1909.3	23.2	22.55	0	21.51	1
		1880	23.2	22.70	0	21.79	1
		1850.7	23.2	22.77	0	21.65	1
	3RB Middle (1)	1909.3	23.2	22.66	0	21.46	1
		1880	23.2	22.73	0	21.65	1
		1850.7	23.2	22.72	0	21.59	1
	3RB Low (0)	1909.3	23.2	22.63	0	21.66	1
		1880	23.2	22.70	0	21.82	1
		1850.7	23.2	22.65	0	21.63	1
	6RB (0)	1909.3	23.2	21.63	1	20.45	2
		1880	23.2	21.92	1	20.75	2
		1850.7	23.2	21.68	1	20.62	2
3 MHz	1RB High (14)	1908.5	23.2	22.75	0	22.04	1
		1880	23.2	22.66	0	21.85	1
		1851.5	23.2	22.68	0	22.00	1
	1RB Middle (7)	1908.5	23.2	22.70	0	21.95	1
		1880	23.2	22.91	0	21.91	1
		1851.5	23.2	22.85	0	22.10	1
	1RB Low (0)	1908.5	23.2	22.65	0	21.79	1
		1880	23.2	22.64	0	21.95	1
		1851.5	23.2	22.78	0	21.80	1
	8RB High (7)	1908.5	23.2	21.49	1	20.74	2
		1880	23.2	21.80	1	20.85	2
		1851.5	23.2	21.74	1	20.91	2
	8RB Middle (4)	1908.5	23.2	21.63	1	20.77	2
		1880	23.2	21.90	1	20.83	2
		1851.5	23.2	21.71	1	20.92	2

	8RB Low (0)	1908.5	23.2	21.52	1	20.78	2	
		1880	23.2	21.70	1	20.84	2	
		1851.5	23.2	21.79	1	20.93	2	
	15RB (0)	1908.5	23.2	21.55	1	20.74	2	
		1880	23.2	21.79	1	20.93	2	
		1851.5	23.2	21.74	1	21.00	2	
5 MHz	1RB High (24)	1907.5	23.2	22.61	0	21.64	1	
		1880	23.2	22.64	0	21.68	1	
		1852.5	23.2	23.04	0	21.83	1	
	1RB Middle (12)	1907.5	23.2	22.71	0	21.63	1	
		1880	23.2	22.75	0	21.84	1	
		1852.5	23.2	22.80	0	21.69	1	
	1RB Low (0)	1907.5	23.2	22.55	0	21.69	1	
		1880	23.2	22.89	0	21.76	1	
		1852.5	23.2	22.59	0	21.62	1	
	12RB High (13)	1907.5	23.2	21.59	1	20.71	2	
		1880	23.2	21.69	1	20.85	2	
		1852.5	23.2	21.79	1	20.83	2	
	12RB Middle (6)	1907.5	23.2	21.72	1	20.78	2	
		1880	23.2	21.70	1	20.74	2	
		1852.5	23.2	21.74	1	20.94	2	
	12RB Low (0)	1907.5	23.2	21.69	1	20.71	2	
		1880	23.2	21.84	1	20.85	2	
		1852.5	23.2	21.72	1	20.94	2	
	25RB (0)	1907.5	23.2	21.66	1	20.69	2	
		1880	23.2	21.74	1	20.70	2	
		1852.5	23.2	21.77	1	20.95	2	
	10 MHz	1RB High (49)	1905	23.2	22.77	0	21.86	1
			1880	23.2	22.80	0	21.95	1
			1855	23.2	22.72	0	21.94	1
1RB Middle (24)		1905	23.2	22.79	0	21.78	1	
		1880	23.2	22.79	0	21.88	1	
		1855	23.2	22.82	0	22.06	1	
1RB Low (0)		1905	23.2	22.71	0	21.76	1	
		1880	23.2	22.84	0	21.87	1	
		1855	23.2	22.79	0	21.95	1	
25RB High (25)		1905	23.2	21.65	1	20.74	2	
		1880	23.2	21.84	1	20.84	2	
		1855	23.2	21.94	1	20.88	2	
25RB Middle (12)		1905	23.2	21.65	1	20.76	2	
		1880	23.2	21.83	1	20.70	2	
		1855	23.2	21.82	1	20.81	2	

	25RB Low (0)	1905	23.2	21.62	1	20.79	2	
		1880	23.2	21.85	1	20.83	2	
		1855	23.2	21.78	1	20.85	2	
	50RB (0)	1905	23.2	21.61	1	20.69	2	
		1880	23.2	21.76	1	20.70	2	
		1855	23.2	21.82	1	20.66	2	
15 MHz	1RB High (74)	1902.5	23.2	22.75	0	21.86	1	
		1880	23.2	22.83	0	22.04	1	
		1857.5	23.2	22.93	0	22.08	1	
	1RB Middle (37)	1902.5	23.2	22.69	0	21.68	1	
		1880	23.2	22.78	0	21.99	1	
		1857.5	23.2	22.93	0	22.11	1	
	1RB Low (0)	1902.5	23.2	22.88	0	21.89	1	
		1880	23.2	22.75	0	21.76	1	
		1857.5	23.2	22.77	0	21.97	1	
	36RB High (38)	1902.5	23.2	21.66	1	20.77	2	
		1880	23.2	21.84	1	20.87	2	
		1857.5	23.2	21.77	1	20.79	2	
	36RB Middle (19)	1902.5	23.2	21.78	1	20.85	2	
		1880	23.2	21.86	1	20.79	2	
		1857.5	23.2	21.83	1	20.86	2	
	36RB Low (0)	1902.5	23.2	21.69	1	20.57	2	
		1880	23.2	21.59	1	20.75	2	
		1857.5	23.2	21.77	1	20.82	2	
	75RB (0)	1902.5	23.2	21.67	1	20.79	2	
		1880	23.2	21.85	1	20.86	2	
		1857.5	23.2	21.79	1	21.00	2	
	20 MHz	1RB High (99)	1900	23.2	22.87	0	21.87	1
			1880	23.2	22.84	0	21.92	1
			1860	23.2	22.80	0	21.97	1
		1RB Middle (50)	1900	23.2	22.68	0	21.77	1
			1880	23.2	22.88	0	21.99	1
			1860	23.2	22.77	0	21.93	1
1RB Low (0)		1900	23.2	22.82	0	22.04	1	
		1880	23.2	22.85	0	21.92	1	
		1860	23.2	22.79	0	21.87	1	
50RB High (50)		1900	23.2	21.67	1	20.68	2	
		1880	23.2	21.79	1	20.74	2	
		1860	23.2	21.92	1	20.84	2	
50RB Middle (25)		1900	23.2	21.71	1	20.67	2	
		1880	23.2	21.82	1	20.77	2	
		1860	23.2	21.79	1	20.74	2	

	50RB Low (0)	1900	23.2	21.60	1	20.57	2
		1880	23.2	21.77	1	20.79	2
		1860	23.2	21.69	1	20.71	2
	100RB (0)	1900	23.2	21.70	1	20.71	2
		1880	23.2	21.77	1	20.76	2
		1860	23.2	21.81	1	20.79	2
Band 4							
Bandwidth (MHz)	RB allocation	Frequency (MHz)	Max. Target Power (dBm)	QPSK		16QAM	
	RB offset (Start RB)			Actual output power (dBm)	MPR	Actual output power (dBm)	MPR
1.4 MHz	1RB High (5)	1754.3	24	23.70	0	22.97	1
		1732.5	24	23.97	0	22.99	1
		1710.7	24	23.52	0	22.85	1
	1RB Middle (3)	1754.3	24	23.90	0	22.98	1
		1732.5	24	24.00	0	23.00	1
		1710.7	24	23.67	0	22.65	1
	1RB Low (0)	1754.3	24	23.87	0	22.96	1
		1732.5	24	23.99	0	22.98	1
		1710.7	24	23.63	0	22.94	1
	3RB High (3)	1754.3	24	23.60	0	22.71	1
		1732.5	24	23.89	0	22.93	1
		1710.7	24	23.54	0	22.89	1
	3RB Middle (1)	1754.3	24	23.62	0	22.66	1
		1732.5	24	23.96	0	22.99	1
		1710.7	24	23.54	0	22.90	1
	3RB Low (0)	1754.3	24	23.59	0	22.73	1
		1732.5	24	23.98	0	22.93	1
		1710.7	24	23.51	0	22.96	1
	6RB (0)	1754.3	24	22.80	1	21.54	2
		1732.5	24	23.00	1	21.83	2
		1710.7	24	22.65	1	21.66	2
3 MHz	1RB High (14)	1753.5	24	23.74	0	22.98	1
		1732.5	24	23.95	0	23.00	1
		1711.5	24	23.56	0	22.76	1
	1RB Middle (7)	1753.5	24	23.86	0	22.91	1
		1732.5	24	23.98	0	23.00	1
		1711.5	24	23.64	0	22.92	1
	1RB Low (0)	1753.5	24	23.78	0	22.97	1
		1732.5	24	23.92	0	22.99	1
		1711.5	24	23.57	0	22.84	1
	8RB High (7)	1753.5	24	22.66	1	21.80	2
		1732.5	24	22.98	1	21.96	2
		1711.5	24	22.50	1	21.56	2

	8RB Middle (4)	1753.5	24	22.59	1	21.73	2
		1732.5	24	22.85	1	21.92	2
		1711.5	24	22.58	1	21.61	2
	8RB Low (0)	1753.5	24	22.66	1	21.73	2
		1732.5	24	22.88	1	21.99	2
		1711.5	24	22.60	1	21.54	2
	15RB (0)	1753.5	24	22.58	1	21.70	2
		1732.5	24	22.97	1	21.99	2
		1711.5	24	22.61	1	21.65	2
5 MHz	1RB High (24)	1752.5	24	23.75	0	22.67	1
		1732.5	24	23.91	0	22.81	1
		1712.5	24	23.94	0	22.56	1
	1RB Middle (12)	1752.5	24	23.64	0	22.57	1
		1732.5	24	23.93	0	22.79	1
		1712.5	24	23.65	0	22.62	1
	1RB Low (0)	1752.5	24	23.73	0	22.70	1
		1732.5	24	23.94	0	22.83	1
		1712.5	24	23.73	0	22.53	1
	12RB High (13)	1752.5	24	22.54	1	21.54	2
		1732.5	24	22.90	1	21.89	2
		1712.5	24	22.55	1	21.60	2
	12RB Middle (6)	1752.5	24	22.64	1	21.65	2
		1732.5	24	22.82	1	21.90	2
		1712.5	24	22.53	1	21.56	2
	12RB Low (0)	1752.5	24	22.66	1	21.77	2
		1732.5	24	22.79	1	21.91	2
		1712.5	24	22.46	1	21.50	2
	25RB (0)	1752.5	24	22.60	1	21.49	2
		1732.5	24	22.69	1	21.74	2
		1712.5	24	22.39	1	21.37	2
10 MHz	1RB High (49)	1750	24	23.79	0	22.89	1
		1732.5	24	23.74	0	22.85	1
		1715	24	23.61	0	22.93	1
	1RB Middle (24)	1750	24	23.83	0	22.94	1
		1732.5	24	23.91	0	22.95	1
		1715	24	23.65	0	22.76	1
	1RB Low (0)	1750	24	23.69	0	22.88	1
		1732.5	24	23.94	0	22.96	1
		1715	24	23.68	0	22.63	1
	25RB High (25)	1750	24	22.50	1	21.52	2
		1732.5	24	22.77	1	21.74	2
		1715	24	22.45	1	21.47	2

	25RB Middle (12)	1750	24	22.58	1	21.59	2	
		1732.5	24	22.70	1	21.78	2	
		1715	24	22.43	1	21.42	2	
	25RB Low (0)	1750	24	22.59	1	21.54	2	
		1732.5	24	22.74	1	21.71	2	
		1715	24	22.42	1	21.42	2	
	50RB (0)	1750	24	22.47	1	21.32	2	
		1732.5	24	22.63	1	21.58	2	
		1715	24	22.31	1	21.27	2	
15 MHz	1RB High (74)	1747.5	24	23.77	0	22.99	1	
		1732.5	24	23.73	0	22.88	1	
		1717.5	24	23.68	0	22.79	1	
	1RB Middle (37)	1747.5	24	23.82	0	22.95	1	
		1732.5	24	23.99	0	22.99	1	
		1717.5	24	23.76	0	22.91	1	
	1RB Low (0)	1747.5	24	23.67	0	22.79	1	
		1732.5	24	23.76	0	22.82	1	
		1717.5	24	23.63	0	22.76	1	
	36RB High (38)	1747.5	24	22.50	1	21.53	2	
		1732.5	24	22.53	1	21.64	2	
		1717.5	24	22.50	1	21.33	2	
	36RB Middle (19)	1747.5	24	22.43	1	21.47	2	
		1732.5	24	22.56	1	21.70	2	
		1717.5	24	22.36	1	21.31	2	
	36RB Low (0)	1747.5	24	22.39	1	21.45	2	
		1732.5	24	22.61	1	21.69	2	
		1717.5	24	22.23	1	21.37	2	
	75RB (0)	1747.5	24	22.43	1	21.36	2	
		1732.5	24	22.48	1	21.58	2	
		1717.5	24	22.33	1	21.25	2	
	20 MHz	1RB High (99)	1745	24	23.78	0	22.94	1
			1732.5	24	23.85	0	22.94	1
			1720	24	23.94	0	22.95	1
		1RB Middle (50)	1745	24	23.82	0	22.86	1
			1732.5	24	24.00	0	23.00	1
			1720	24	23.74	0	22.80	1
1RB Low (0)		1745	24	23.71	0	22.77	1	
		1732.5	24	23.56	0	22.67	1	
		1720	24	23.54	0	22.62	1	
50RB High (50)		1745	24	22.48	1	21.45	2	
		1732.5	24	22.50	1	21.46	2	
		1720	24	22.48	1	21.33	2	

	50RB Middle (25)	1745	24	22.41	1	21.39	2	
		1732.5	24	22.62	1	21.59	2	
		1720	24	22.36	1	21.23	2	
	50RB Low (0)	1745	24	22.30	1	21.28	2	
		1732.5	24	22.45	1	21.49	2	
		1720	24	22.26	1	21.13	2	
	100RB (0)	1745	24	22.45	1	21.36	2	
		1732.5	24	22.58	1	21.49	2	
		1720	24	22.35	1	21.26	2	
Band 5								
Bandwidth (MHz)	RB allocation	Frequency (MHz)	Max. Target Power (dBm)	QPSK		16QAM		
	RB offset (Start RB)			Actual output power (dBm)	MPR	Actual output power (dBm)	MPR	
1.4 MHz	1RB High (5)	848.3	24	23.48	0	22.61	1	
		836.5	24	23.67	0	22.88	1	
		824.7	24	23.33	0	22.46	1	
	1RB Middle (3)	848.3	24	23.62	0	22.67	1	
		836.5	24	23.70	0	22.75	1	
		824.7	24	23.29	0	22.36	1	
	1RB Low (0)	848.3	24	23.64	0	22.95	1	
		836.5	24	23.67	0	22.89	1	
		824.7	24	23.42	0	22.64	1	
	3RB High (3)	848.3	24	23.50	0	22.49	1	
		836.5	24	23.56	0	22.87	1	
		824.7	24	23.45	0	22.73	1	
	3RB Middle (1)	848.3	24	23.55	0	22.44	1	
		836.5	24	23.67	0	22.83	1	
		824.7	24	23.29	0	22.73	1	
	3RB Low (0)	848.3	24	23.54	0	22.45	1	
		836.5	24	23.63	0	22.93	1	
		824.7	24	23.41	0	22.52	1	
	6RB (0)	848.3	24	22.57	1	21.42	2	
		836.5	24	22.64	1	21.66	2	
		824.7	24	22.33	1	21.43	2	
	3 MHz	1RB High (14)	847.5	24	23.52	0	22.75	1
			836.5	24	23.33	0	22.72	1
			825.5	24	23.41	0	22.66	1
		1RB Middle (7)	847.5	24	23.34	0	22.04	1
			836.5	24	23.53	0	22.15	1
			825.5	24	23.60	0	22.54	1

	1RB Low (0)	847.5	24	23.34	0	22.36	1	
		836.5	24	23.50	0	22.22	1	
		825.5	24	23.45	0	22.51	1	
	8RB High (7)	847.5	24	22.52	1	21.56	2	
		836.5	24	22.54	1	21.54	2	
		825.5	24	22.38	1	21.41	2	
	8RB Middle (4)	847.5	24	22.57	1	21.61	2	
		836.5	24	22.55	1	21.53	2	
		825.5	24	22.38	1	21.51	2	
	8RB Low (0)	847.5	24	22.44	1	21.49	2	
		836.5	24	22.55	1	21.53	2	
		825.5	24	22.37	1	21.40	2	
	15RB (0)	847.5	24	22.48	1	21.42	2	
		836.5	24	22.57	1	21.60	2	
		825.5	24	22.28	1	21.66	2	
5 MHz	1RB High (24)	846.5	24	23.69	0	22.77	1	
		836.5	24	23.62	0	22.76	1	
		826.5	24	23.59	0	22.61	1	
	1RB Middle (12)	846.5	24	23.44	0	22.44	1	
		836.5	24	23.61	0	22.58	1	
		826.5	24	23.51	0	22.41	1	
	1RB Low (0)	846.5	24	23.39	0	22.65	1	
		836.5	24	23.65	0	22.49	1	
		826.5	24	23.44	0	22.52	1	
	12RB High (13)	846.5	24	22.66	1	21.69	2	
		836.5	24	22.62	1	21.68	2	
		826.5	24	22.42	1	21.38	2	
	12RB Middle (6)	846.5	24	22.37	1	21.53	2	
		836.5	24	22.55	1	21.72	2	
		826.5	24	22.40	1	21.41	2	
	12RB Low (0)	846.5	24	22.56	1	21.70	2	
		836.5	24	22.52	1	21.62	2	
		826.5	24	22.37	1	21.57	2	
	25RB (0)	846.5	24	22.48	1	21.45	2	
		836.5	24	22.54	1	21.59	2	
		826.5	24	22.35	1	21.50	2	
	10 MHz	1RB High (49)	844.0	24	23.55	0	22.99	1
			836.5	24	23.81	0	22.95	1
			829.0	24	23.57	0	22.89	1
1RB Middle (24)		844.0	24	23.66	0	22.74	1	
		836.5	24	23.72	0	22.85	1	
		829.0	24	23.36	0	22.35	1	

	1RB Low (0)	844.0	24	23.66	0	22.71	1
		836.5	24	23.61	0	22.76	1
		829.0	24	23.46	0	22.50	1
	25RB High (25)	844.0	24	22.40	1	21.43	2
		836.5	24	22.54	1	21.57	2
		829.0	24	22.42	1	21.32	2
	25RB Middle (12)	844.0	24	22.32	1	21.35	2
		836.5	24	22.50	1	21.53	2
		829.0	24	22.35	1	21.42	2
	25RB Low (0)	844.0	24	22.34	1	21.45	2
		836.5	24	22.43	1	21.56	2
		829.0	24	22.31	1	21.35	2
	50RB (0)	844.0	24	22.44	1	21.35	2
		836.5	24	22.47	1	21.34	2
		829.0	24	22.28	1	21.16	2

11.5 Wi-Fi and BT Measurement result

The output power of BT antenna is as following:

Mode	Peak Conducted Power (dBm)		
	Channel 0 (2402MHz)	Channel 39 (2441MHz)	Channel 78 (2480MHz)
GFSK	6.10	6.75	4.01
EDR2M-4_DQPSK	7.06	7.65	5.01
EDR3M-8DPSK	7.44	7.93	5.39

The average conducted power for Wi-Fi is as following:

802.11b (dBm)

Channel\data rate	1Mbps	2Mbps	5.5Mbps	11Mbps
1	15.26	15.24	15.35	15.30
6	14.95	14.91	14.98	14.95
11	15.08	15.10	15.14	15.11

802.11g (dBm)

Channel\data rate	6Mbps	9Mbps	12Mbps	18Mbps	24Mbps	36Mbps	48Mbps	54Mbps
1	13.76	13.75	13.75	13.71	13.66	13.65	13.58	13.51
6	13.58	13.54	13.53	13.48	13.45	13.42	13.35	13.22
11	13.80	13.77	13.74	13.72	13.68	13.64	13.58	13.46

802.11n (dBm) - HT20 (2.4G)

Channel\data rate	MCS0	MCS1	MCS2	MCS3	MCS4	MCS5	MCS6	MCS7
1	12.83	12.82	12.80	12.73	12.70	12.65	12.63	12.60
6	12.68	12.65	12.61	12.56	12.53	12.47	12.46	12.43
11	12.85	12.82	12.80	12.75	12.69	12.65	12.61	12.58

802.11a (dBm)

Channel\data rate	6Mbps	9Mbps	12Mbps	18Mbps	24Mbps	36Mbps	48Mbps	54Mbps
36(5180 MHz)	12.47	12.48	12.46	12.46	12.47	12.47	12.48	12.48
40(5200 MHz)	12.54	12.54	12.53	12.53	12.48	12.51	12.45	12.46
44(5220 MHz)	12.44	12.43	12.43	12.43	12.42	12.42	12.43	12.42
48(5240 MHz)	12.24	12.24	12.24	12.23	12.19	12.23	12.22	12.16
52(5260 MHz)	12.64	12.63	12.64	12.64	12.63	12.63	12.57	12.62
56(5280 MHz)	12.52	12.52	12.53	12.51	12.44	12.51	12.46	12.52
60(5300 MHz)	12.23	12.23	12.22	12.22	12.21	12.21	12.19	12.19
64(5320 MHz)	12.62	12.62	12.63	12.63	12.62	12.62	12.60	12.59
100(5500 MHz)	12.63	12.63	12.62	12.62	12.62	12.59	12.59	12.60
104(5520 MHz)	12.52	12.53	12.52	12.52	12.50	12.50	12.49	12.49
108(5540 MHz)	12.84	12.83	12.83	12.82	12.81	12.81	12.80	12.79
112(5560 MHz)	12.73	12.73	12.72	12.72	12.71	12.70	12.71	12.71
116(5580 MHz)	12.83	12.83	12.82	12.81	12.78	12.80	12.80	12.79
120(5600 MHz)	12.43	12.43	12.42	12.42	12.42	12.43	12.43	12.41
124(5620 MHz)	12.34	12.33	12.33	12.34	12.24	12.23	12.24	12.32
128(5640 MHz)	12.73	12.73	12.73	12.72	12.72	12.72	12.72	12.72
132(5660 MHz)	12.81	12.80	12.80	12.78	12.78	12.79	12.79	12.79
136(5680 MHz)	12.64	12.62	12.62	12.61	12.58	12.60	12.59	12.60
140(5700 MHz)	12.33	12.31	12.31	12.32	12.30	12.30	12.29	12.29
149(5745 MHz)	12.93	12.93	12.92	12.92	12.91	12.91	12.90	12.90
153(5765 MHz)	12.93	12.92	12.92	12.91	12.91	12.90	12.89	12.89
157(5785 MHz)	12.81	12.81	12.80	12.80	12.79	12.79	12.78	12.79
161(5805 MHz)	12.70	12.70	12.71	12.71	12.69	12.69	12.68	12.68
165(5825 MHz)	12.72	12.72	12.71	12.70	12.69	12.69	12.68	12.68

802.11n (dBm) - HT20 (5G)

Channel\data rate	6Mbps	9Mbps	12Mbps	18Mbps	24Mbps	36Mbps	48Mbps	54Mbps
36(5180 MHz)	12.82	12.84	12.84	12.86	12.86	12.87	12.88	12.88
40(5200 MHz)	12.73	12.78	12.76	12.78	12.78	12.79	12.79	12.80
44(5220 MHz)	12.61	12.65	12.63	12.68	12.68	12.70	12.71	12.73
48(5240 MHz)	12.33	12.36	12.38	12.36	12.37	12.37	12.38	12.38
52(5260 MHz)	12.84	12.86	12.86	12.87	12.87	12.87	12.88	12.89
56(5280 MHz)	12.63	12.66	12.69	12.69	12.70	12.71	12.71	12.72
60(5300 MHz)	12.44	12.45	12.45	12.47	12.47	12.46	12.46	12.46
64(5320 MHz)	12.81	12.84	12.85	12.88	12.88	12.90	12.90	12.90
100(5500 MHz)	12.47	12.49	12.49	12.50	12.50	12.52	12.53	12.55
104(5520 MHz)	12.38	12.41	12.46	12.42	12.45	12.45	12.47	12.48
108(5540 MHz)	12.72	12.75	12.74	12.76	12.78	12.79	12.79	12.80
112(5560 MHz)	12.66	12.68	12.67	12.67	12.68	12.69	12.70	12.70
116(5580 MHz)	12.78	12.76	12.78	12.77	12.79	12.80	12.81	12.81
120(5600 MHz)	12.39	12.37	12.40	12.39	12.40	12.41	12.41	12.42

124(5620 MHz)	12.68	12.70	12.70	12.71	12.72	12.72	12.74	12.73
128(5640 MHz)	12.69	12.70	12.68	12.70	12.72	12.71	12.73	12.73
132(5660 MHz)	12.74	12.76	12.78	12.78	12.80	12.79	12.79	12.80
136(5680 MHz)	12.75	12.78	12.78	12.80	12.80	12.82	12.83	12.83
140(5700 MHz)	12.71	12.74	12.73	12.75	12.75	12.76	12.80	12.80
149(5745 MHz)	12.93	12.95	12.96	12.96	12.97	12.97	12.98	12.99
153(5765 MHz)	13.00	12.99	12.98	12.98	12.96	12.97	12.98	12.99
157(5785 MHz)	12.85	12.85	12.86	12.87	12.87	13.89	12.89	12.90
161(5805 MHz)	12.66	12.67	12.67	12.68	12.68	12.80	12.80	12.80
165(5825 MHz)	12.76	12.78	12.78	12.80	12.80	12.82	12.82	12.83

802.11n (dBm) - HT40 (5G)

Channel\data rate	MCS0	MCS1	MCS2	MCS3	MCS4	MCS5	MCS6	MCS7
38(5190 MHz)	8.77	8.48	8.30	8.26	8.16	8.15	8.06	8.00
46(5230 MHz)	8.38	8.08	7.88	7.83	7.75	7.75	7.65	7.61
54(5270 MHz)	7.74	7.45	7.25	7.20	7.08	7.11	7.01	6.95
62(5310 MHz)	7.16	6.68	6.66	6.62	6.51	6.52	6.42	6.38
102(5510 MHz)	8.91	8.62	8.41	8.37	8.26	8.27	8.17	8.12
110(5550 MHz)	8.21	7.93	7.74	7.69	7.58	7.58	7.50	7.46
118(5590 MHz)	8.41	8.13	7.93	7.89	7.78	7.79	7.69	7.66
126(5630 MHz)	9.23	8.94	8.75	8.70	8.59	8.60	8.50	8.45
134(5670 MHz)	9.05	8.76	8.58	8.52	8.42	8.43	8.34	8.29
151(5755 MHz)	9.99	9.69	9.50	9.45	9.35	9.35	9.26	9.22
159(5795 MHz)	10.73	10.44	10.15	10.20	10.09	10.10	10.01	9.96

11.6 Hotspot

There is power reduction enabled for this model for GSM1900, WCDMA1900 and LTE Band 2&4. The power reduction is enabled when the user enables hotspot mode via the manufacturer software. The tables below show the measured powers with hotspot.

Table 11.14: The conducted power measurement results for GPRS and EGPRS

PCS1900 GPRS (GMSK)	Measured Power (dBm)			calculation	Averaged Power (dBm)		
	810	661	512		810	661	512
1 Txslot	27.50	27.78	27.90	-9.03dB	18.47	18.75	18.87
2 Txslots	24.75	24.93	25.05	-6.02dB	18.73	18.91	19.03
3Txslots	22.90	23.09	23.28	-4.26dB	18.64	18.83	19.02
4 Txslots	21.70	21.85	21.99	-3.01dB	18.69	18.84	18.98
PCS1900 EGPRS (GMSK)	Measured Power (dBm)			calculation	Averaged Power (dBm)		
	810	661	512		810	661	512
1 Txslot	27.44	27.48	27.74	-9.03dB	18.41	18.45	18.71
2 Txslots	24.74	24.85	24.94	-6.02dB	18.72	18.83	18.92
3Txslots	22.92	22.99	23.18	-4.26dB	18.66	18.73	18.92
4 Txslots	21.79	21.85	21.94	-3.01dB	18.78	18.84	18.93

PCS1900 EGPRS (8PSK)	Measured Power (dBm)			calculation	Averaged Power (dBm)		
	810	661	512		810	661	512
1 Txslot	23.77	23.83	24.01	-9.03dB	14.74	14.80	14.98
2 Txslots	21.65	21.76	21.94	-6.02dB	15.63	15.74	15.92
3Txslots	20.56	20.67	20.76	-4.26dB	16.30	16.41	16.50
4 Txslots	19.62	19.65	19.80	-3.01dB	16.61	16.64	16.79

NOTES:

1) Division Factors

To average the power, the division factor is as follows:

1TX-slot = 1 transmit time slot out of 8 time slots=> conducted power divided by (8/1) => -9.03dB

2TX-slots = 2 transmit time slots out of 8 time slots=> conducted power divided by (8/2) => -6.02dB

3TX-slots = 3 transmit time slots out of 8 time slots=> conducted power divided by (8/3) => -4.26dB

4TX-slots = 4 transmit time slots out of 8 time slots=> conducted power divided by (8/4) => -3.01dB

According to the conducted power as above, the body measurements are performed with 2Txslots for GPRS and 4Txslots for EGPRS.

Table 11.15: The conducted Power for WCDMA1900

Item	band	FDDII result		
	ARFCN	9538 (1907.6MHz)	9400 (1880MHz)	9262 (1852.4MHz)
WCDMA	\	19.39	19.43	19.50

Table 11.16: The conducted Power for LTE

Band 2							
Bandwidth (MHz)	RB allocation	Frequency (MHz)	Max. Target Power (dBm)	QPSK		16QAM	
	RB offset (Start RB)			Actual output power (dBm)	MPR	Actual output power (dBm)	MPR
1.4 MHz	1RB High (5)	1909.3	19.5	18.61	0	18.68	0
		1880	19.5	19.06	0	19.09	0
		1850.7	19.5	18.91	0	18.87	0
	1RB Middle (3)	1909.3	19.5	18.70	0	18.85	0
		1880	19.5	19.12	0	18.80	0
		1850.7	19.5	19.03	0	19.02	0
	1RB Low (0)	1909.3	19.5	18.82	0	18.78	0
		1880	19.5	18.94	0	19.07	0
		1850.7	19.5	18.97	0	19.09	0
	3RB High (3)	1909.3	19.5	18.54	0	18.60	0
		1880	19.5	18.92	0	18.90	0
		1850.7	19.5	19.01	0	18.89	0
	3RB Middle (1)	1909.3	19.5	18.50	0	18.38	0
		1880	19.5	18.82	0	18.71	0
		1850.7	19.5	18.77	0	18.71	0
	3RB Low (0)	1909.3	19.5	18.49	0	18.66	0
		1880	19.5	18.95	0	18.76	0
		1850.7	19.5	18.85	0	18.74	0

	6RB (0)	1909.3	19.5	18.69	0	18.46	0	
		1880	19.5	18.85	0	18.58	0	
		1850.7	19.5	18.87	0	18.62	0	
3 MHz	1RB High (14)	1908.5	19.5	18.62	0	18.99	0	
		1880	19.5	18.91	0	19.28	0	
		1851.5	19.5	19.03	0	19.06	0	
	1RB Middle (7)	1908.5	19.5	18.73	0	18.87	0	
		1880	19.5	18.93	0	18.89	0	
		1851.5	19.5	19.00	0	19.02	0	
	1RB Low (0)	1908.5	19.5	18.81	0	18.98	0	
		1880	19.5	18.83	0	19.07	0	
		1851.5	19.5	18.76	0	19.10	0	
	8RB High (7)	1908.5	19.5	18.47	0	18.78	0	
		1880	19.5	18.86	0	18.97	0	
		1851.5	19.5	19.16	0	18.91	0	
	8RB Middle (4)	1908.5	19.5	18.71	0	18.78	0	
		1880	19.5	18.82	0	18.94	0	
		1851.5	19.5	19.08	0	19.24	0	
	8RB Low (0)	1908.5	19.5	18.61	0	18.82	0	
		1880	19.5	18.70	0	19.02	0	
		1851.5	19.5	18.89	0	19.00	0	
	15RB (0)	1908.5	19.5	18.74	0	18.70	0	
		1880	19.5	18.93	0	18.92	0	
		1851.5	19.5	18.77	0	19.04	0	
	5 MHz	1RB High (24)	1907.5	19.5	18.74	0	18.61	0
			1880	19.5	18.85	0	18.47	0
			1852.5	19.5	19.22	0	18.95	0
1RB Middle (12)		1907.5	19.5	18.89	0	18.74	0	
		1880	19.5	18.95	0	18.78	0	
		1852.5	19.5	18.91	0	18.80	0	
1RB Low (0)		1907.5	19.5	18.68	0	18.45	0	
		1880	19.5	18.80	0	18.94	0	
		1852.5	19.5	18.82	0	18.71	0	
12RB High (13)		1907.5	19.5	18.65	0	18.80	0	
		1880	19.5	18.81	0	18.92	0	
		1852.5	19.5	19.04	0	18.96	0	
12RB Middle (6)		1907.5	19.5	18.67	0	18.73	0	
		1880	19.5	18.72	0	18.90	0	
		1852.5	19.5	18.93	0	18.78	0	
12RB Low (0)		1907.5	19.5	18.70	0	18.76	0	
		1880	19.5	18.82	0	18.80	0	
		1852.5	19.5	18.79	0	18.84	0	

	25RB (0)	1907.5	19.5	18.58	0	18.56	0	
		1880	19.5	18.85	0	18.97	0	
		1852.5	19.5	18.96	0	18.96	0	
10 MHz	1RB High (49)	1905	19.5	18.84	0	19.06	0	
		1880	19.5	18.84	0	18.97	0	
		1855	19.5	18.80	0	19.06	0	
	1RB Middle (24)	1905	19.5	18.70	0	18.96	0	
		1880	19.5	18.99	0	18.94	0	
		1855	19.5	19.16	0	19.08	0	
	1RB Low (0)	1905	19.5	18.49	0	18.80	0	
		1880	19.5	19.10	0	19.11	0	
		1855	19.5	18.89	0	19.09	0	
	25RB High (25)	1905	19.5	18.76	0	18.79	0	
		1880	19.5	18.95	0	18.79	0	
		1855	19.5	19.08	0	18.98	0	
	25RB Middle (12)	1905	19.5	18.74	0	18.66	0	
		1880	19.5	18.82	0	18.77	0	
		1855	19.5	19.03	0	19.07	0	
	25RB Low (0)	1905	19.5	18.79	0	18.91	0	
		1880	19.5	18.89	0	18.84	0	
		1855	19.5	18.85	0	18.84	0	
	50RB (0)	1905	19.5	18.62	0	18.58	0	
		1880	19.5	18.88	0	18.59	0	
		1855	19.5	18.91	0	18.80	0	
	15 MHz	1RB High (74)	1902.5	19.5	18.83	0	18.96	0
			1880	19.5	18.93	0	18.88	0
			1857.5	19.5	19.00	0	19.24	0
1RB Middle (37)		1902.5	19.5	18.77	0	18.90	0	
		1880	19.5	18.95	0	19.11	0	
		1857.5	19.5	19.11	0	19.25	0	
1RB Low (0)		1902.5	19.5	18.80	0	19.03	0	
		1880	19.5	18.88	0	19.01	0	
		1857.5	19.5	18.97	0	19.02	0	
36RB High (38)		1902.5	19.5	18.80	0	18.83	0	
		1880	19.5	18.82	0	18.98	0	
		1857.5	19.5	19.03	0	18.99	0	
36RB Middle (19)		1902.5	19.5	18.79	0	18.74	0	
		1880	19.5	18.94	0	19.04	0	
		1857.5	19.5	19.04	0	18.91	0	
36RB Low (0)		1902.5	19.5	18.86	0	18.72	0	
		1880	19.5	18.78	0	18.87	0	
		1857.5	19.5	18.97	0	18.94	0	

	75RB (0)	1902.5	19.5	18.75	0	18.79	0	
		1880	19.5	18.83	0	18.99	0	
		1857.5	19.5	18.88	0	18.90	0	
20 MHz	1RB High (99)	1900	19.5	18.61	0	18.13	0	
		1880	19.5	18.79	0	18.35	0	
		1860	19.5	18.90	0	19.05	0	
	1RB Middle (50)	1900	19.5	18.58	0	18.09	0	
		1880	19.5	18.86	0	18.36	0	
		1860	19.5	19.09	0	19.17	0	
	1RB Low (0)	1900	19.5	18.65	0	18.23	0	
		1880	19.5	18.79	0	18.30	0	
		1860	19.5	19.05	0	18.77	0	
	50RB High (50)	1900	19.5	18.74	0	18.54	0	
		1880	19.5	18.86	0	18.72	0	
		1860	19.5	18.99	0	18.95	0	
	50RB Middle (25)	1900	19.5	18.71	0	18.84	0	
		1880	19.5	18.86	0	18.77	0	
		1860	19.5	19.02	0	18.61	0	
	50RB Low (0)	1900	19.5	18.71	0	18.97	0	
		1880	19.5	19.11	0	18.92	0	
		1860	19.5	18.91	0	18.76	0	
	100RB (0)	1900	19.5	18.79	0	18.82	0	
		1880	19.5	18.94	0	18.85	0	
		1860	19.5	19.06	0	18.95	0	
	Band 4							
	Bandwidth (MHz)	RB allocation	Frequency (MHz)	Max. Target Power (dBm)	QPSK		16QAM	
		RB offset (Start RB)			Actual output power (dBm)	MPR	Actual output power (dBm)	MPR
	1.4 MHz	1RB High (5)	1754.3	20	19.70	0	19.82	0
			1732.5	20	20.00	0	20.00	0
			1710.7	20	19.44	0	18.86	0
1RB Middle (3)		1754.3	20	19.69	0	19.75	0	
		1732.5	20	19.93	0	19.89	0	
		1710.7	20	19.46	0	19.08	0	
1RB Low (0)		1754.3	20	19.65	0	19.76	0	
		1732.5	20	19.94	0	19.81	0	
		1710.7	20	19.35	0	18.86	0	
3RB High (3)		1754.3	20	19.65	0	19.44	0	
		1732.5	20	19.87	0	19.77	0	
		1710.7	20	19.46	0	19.37	0	

	3RB Middle (1)	1754.3	20	19.66	0	19.46	0
		1732.5	20	19.79	0	19.69	0
		1710.7	20	19.49	0	19.40	0
	3RB Low (0)	1754.3	20	19.64	0	19.61	0
		1732.5	20	19.78	0	19.69	0
		1710.7	20	19.47	0	19.50	0
	6RB (0)	1754.3	20	19.61	0	19.35	0
		1732.5	20	19.85	0	19.53	0
		1710.7	20	19.53	0	19.26	0
3 MHz	1RB High (14)	1753.5	20	19.72	0	19.74	0
		1732.5	20	19.87	0	19.98	0
		1711.5	20	19.49	0	19.68	0
	1RB Middle (7)	1753.5	20	19.65	0	19.61	0
		1732.5	20	19.87	0	19.92	0
		1711.5	20	19.60	0	19.66	0
	1RB Low (0)	1753.5	20	19.70	0	19.70	0
		1732.5	20	19.81	0	19.89	0
		1711.5	20	19.53	0	19.55	0
	8RB High (7)	1753.5	20	19.55	0	19.68	0
		1732.5	20	19.75	0	19.85	0
		1711.5	20	19.49	0	19.42	0
	8RB Middle (4)	1753.5	20	19.51	0	19.70	0
		1732.5	20	19.75	0	19.89	0
		1711.5	20	19.45	0	19.49	0
	8RB Low (0)	1753.5	20	19.56	0	19.46	0
		1732.5	20	19.67	0	19.80	0
		1711.5	20	19.49	0	19.53	0
	15RB (0)	1753.5	20	19.54	0	19.32	0
		1732.5	20	19.74	0	19.75	0
		1711.5	20	19.49	0	19.43	0
5 MHz	1RB High (24)	1752.5	20	19.78	0	19.60	0
		1732.5	20	19.78	0	19.70	0
		1712.5	20	19.59	0	19.47	0
	1RB Middle (12)	1752.5	20	19.68	0	19.57	0
		1732.5	20	19.83	0	19.70	0
		1712.5	20	19.46	0	19.43	0
	1RB Low (0)	1752.5	20	19.70	0	19.53	0
		1732.5	20	19.77	0	19.75	0
		1712.5	20	19.51	0	19.39	0
	12RB High (13)	1752.5	20	19.68	0	19.50	0
		1732.5	20	19.75	0	19.74	0
		1712.5	20	19.41	0	19.42	0

	12RB Middle (6)	1752.5	20	19.57	0	19.49	0	
		1732.5	20	19.79	0	19.77	0	
		1712.5	20	19.49	0	19.40	0	
	12RB Low (0)	1752.5	20	19.45	0	19.54	0	
		1732.5	20	19.72	0	19.69	0	
		1712.5	20	19.45	0	19.45	0	
	25RB (0)	1752.5	20	19.70	0	19.45	0	
		1732.5	20	19.73	0	19.65	0	
		1712.5	20	19.38	0	19.32	0	
10 MHz	1RB High (49)	1750	20	19.61	0	19.54	0	
		1732.5	20	19.64	0	19.59	0	
		1715	20	19.57	0	19.68	0	
	1RB Middle (24)	1750	20	19.72	0	19.73	0	
		1732.5	20	19.96	0	19.82	0	
		1715	20	19.60	0	19.60	0	
	1RB Low (0)	1750	20	19.54	0	19.81	0	
		1732.5	20	19.84	0	19.86	0	
		1715	20	19.50	0	19.59	0	
	25RB High (25)	1750	20	19.44	0	19.54	0	
		1732.5	20	19.59	0	19.66	0	
		1715	20	19.35	0	19.42	0	
	25RB Middle (12)	1750	20	19.55	0	19.46	0	
		1732.5	20	19.56	0	19.62	0	
		1715	20	19.41	0	19.38	0	
	25RB Low (0)	1750	20	19.56	0	19.55	0	
		1732.5	20	19.81	0	19.63	0	
		1715	20	19.44	0	19.40	0	
	50RB (0)	1750	20	19.44	0	19.15	0	
		1732.5	20	19.58	0	19.51	0	
		1715	20	19.34	0	19.15	0	
	15 MHz	1RB High (74)	1747.5	20	19.77	0	19.72	0
			1732.5	20	19.63	0	19.66	0
			1717.5	20	19.56	0	19.63	0
1RB Middle (37)		1747.5	20	19.72	0	19.82	0	
		1732.5	20	20.00	0	20.00	0	
		1717.5	20	19.67	0	19.72	0	
1RB Low (0)		1747.5	20	19.89	0	19.49	0	
		1732.5	20	19.54	0	19.48	0	
		1717.5	20	19.57	0	19.56	0	
36RB High (38)		1747.5	20	19.43	0	19.50	0	
		1732.5	20	19.53	0	19.29	0	
		1717.5	20	19.35	0	19.33	0	

	36RB Middle (19)	1747.5	20	19.46	0	19.48	0
		1732.5	20	19.59	0	19.55	0
		1717.5	20	19.34	0	19.30	0
	36RB Low (0)	1747.5	20	19.41	0	19.44	0
		1732.5	20	19.46	0	19.59	0
		1717.5	20	19.30	0	19.30	0
	75RB (0)	1747.5	20	19.38	0	19.44	0
		1732.5	20	19.49	0	19.60	0
		1717.5	20	19.33	0	19.20	0
20 MHz	1RB High (99)	1745	20	19.78	0	19.83	0
		1732.5	20	19.75	0	19.67	0
		1720	20	19.79	0	19.89	0
	1RB Middle (50)	1745	20	19.69	0	19.79	0
		1732.5	20	19.71	0	19.97	0
		1720	20	19.62	0	19.66	0
	1RB Low (0)	1745	20	19.81	0	19.40	0
		1732.5	20	19.51	0	19.44	0
		1720	20	19.51	0	19.60	0
	50RB High (50)	1745	20	19.57	0	19.41	0
		1732.5	20	19.55	0	19.41	0
		1720	20	19.50	0	19.28	0
	50RB Middle (25)	1745	20	19.50	0	19.36	0
		1732.5	20	19.65	0	19.53	0
		1720	20	19.38	0	19.19	0
	50RB Low (0)	1745	20	19.39	0	19.26	0
		1732.5	20	19.60	0	19.38	0
		1720	20	19.24	0	19.17	0
	100RB (0)	1745	20	19.44	0	19.33	0
		1732.5	20	19.51	0	19.43	0
		1720	20	19.33	0	19.28	0

12 Simultaneous TX SAR Considerations

12.1 Introduction

The following procedures adopted from “FCC SAR Considerations for Cell Phones with Multiple Transmitters” are applicable to handsets with built-in unlicensed transmitters such as 802.11 a/b/g and Bluetooth devices which may simultaneously transmit with the licensed transmitter. For this device, the BT and Wi-Fi can transmit simultaneous with other transmitters.

12.2 Transmit Antenna Separation Distances

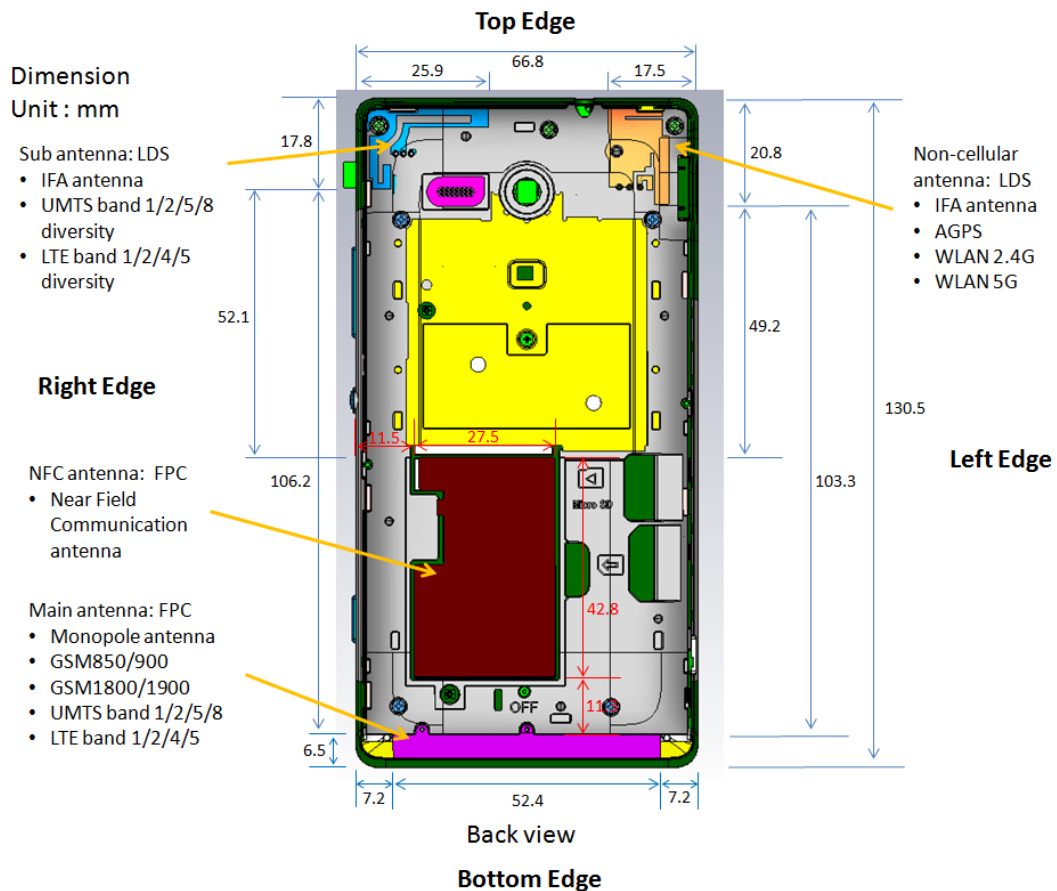

Picture 12.1 Antenna Locations

12.3 SAR Measurement Positions

According to the KDB941225 D06 Hot Spot SAR v01, the edges with less than 2.5 cm distance to the antennas need to be tested for SAR.

SAR measurement positions						
Mode	Front	Rear	Left edge	Right edge	Top edge	Bottom edge
Main antenna	Yes	Yes	Yes	Yes	No	Yes
WLAN	Yes	Yes	Yes	No	Yes	No

12.4 Standalone SAR Test Exclusion Considerations

Standalone 1-g head or body SAR evaluation by measurement or numerical simulation is not required when the corresponding SAR Exclusion Threshold condition, listed below, is satisfied. The 1-g SAR test exclusion threshold for 100 MHz to 6 GHz at test separation distances ≤ 50 mm are determined by:

$[(\text{max. power of channel, including tune-up tolerance, mW}) / (\text{min. test separation distance, mm})] \cdot [\sqrt{f(\text{GHz})}] \leq 3.0$ for 1-g SAR, where

- $f(\text{GHz})$ is the RF channel transmit frequency in GHz
- Power and distance are rounded to the nearest mW and mm before calculation
- The result is rounded to one decimal place for comparison

Appendix A

SAR Test Exclusion Thresholds for 100 MHz – 6 GHz and ≤ 50 mm

Approximate SAR Test Exclusion Power Thresholds at Selected Frequencies and Test Separation Distances are illustrated in the following Table.

MHz	5	10	15	20	25	mm
150	39	77	116	155	194	SAR Test Exclusion Threshold (mW)
300	27	55	82	110	137	
450	22	45	67	89	112	
835	16	33	49	66	82	
900	16	32	47	63	79	
1500	12	24	37	49	61	
1900	11	22	33	44	54	
2450	10	19	29	38	48	
3600	8	16	24	32	40	
5200	7	13	20	26	33	
5400	6	13	19	26	32	
5800	6	12	19	25	31	

Picture 12.2 Power Thresholds

Table 12.1: Standalone SAR test exclusion considerations

Band/Mode	F(GHz)	SAR test exclusion threshold (mW)	RF output power		SAR test exclusion
			dBm	mW	
Bluetooth	2.441	19	7.93	6.21	Yes
2.4GHz WLAN 802.11 b	2.45	19	15.35	34.28	No
5GHz WLAN 802.11 a	5.745	12	12.9	19.50	No
5GHz WLAN 802.11 n	5.745	12	13.0	19.95	No

13 Evaluation of Simultaneous

Table 13.1: The sum of reported SAR values for main antenna and WiFi

	Position	GSM/WCDMA	WiFi (DTS)	Sum1	WiFi (UNII)	Sum2
Maximum reported SAR value for Head	Right hand, Touch cheek	0.67	0.23	0.90	0.05	0.72
Maximum reported SAR value for Body	Front	1.33	0.03	1.36	/	/
	Rear	0.76	0.13	0.89	0.07	0.83

Note1: Sum1 is GSM/WCDMA + WiFi (DTS). Sum2 is GSM/WCDMA + WiFi (UNII).

Table 13.2: The sum of reported SAR values for main antenna and Bluetooth

	Position	Main antenna	BT*	Sum
Highest reported SAR value for Head	Right hand, Touch cheek	0.67	0.26	0.93
Highest reported SAR value for Body	Front	1.33	0.26	1.59

BT* - Estimated SAR for Bluetooth (see the table 13.3)

Table 13.3: Estimated SAR for Bluetooth

Mode/Band	F (GHz)	Distance (mm)	Upper limit of power *		Estimated _{1g} (W/kg)
			dBm	mW	
Bluetooth	2.441	10	11	12.59	0.26

* - Maximum possible output power declared by manufacturer

When standalone SAR test exclusion applies to an antenna that transmits simultaneously with other antennas, the standalone SAR must be estimated according to following to determine simultaneous transmission SAR test exclusion:

$(\text{max. power of channel, including tune-up tolerance, mW}) / (\text{min. test separation distance, mm}) \cdot [\sqrt{f(\text{GHz})} / x] \text{ W/kg}$ for test separation distances $\leq 50 \text{ mm}$;

where $x = 7.5$ for 1-g SAR.

When the minimum test separation distance is $< 5 \text{ mm}$, a distance of 5 mm is applied to determine SAR test exclusion

Conclusion:

According to the above tables, the sum of reported SAR values is $< 1.6 \text{ W/kg}$. So the simultaneous transmission SAR with volume scans is not required.

14 SAR Test Result

It is determined by user manual for the distance between the EUT and the phantom bottom.

The distance is 10mm for data and 15mm for speech in all bands except GSM1900, WCDMA1900 and LTE Band2&4 and just applied to the condition of body worn accessory. About GSM1900, WCDMA1900 and LTE Band2&4, the distance is 10mm for AP ON and 15mm for AP OFF.

It is performed for all SAR measurements with area scan based 1-g SAR estimation (Fast SAR). A zoom scan measurement is added when the estimated 1-g SAR is the highest measured SAR in each exposure configuration, wireless mode and frequency band combination or more than 1.2W/kg.

The calculated SAR is obtained by the following formula:

$$\text{Reported SAR} = \text{Measured SAR} \times 10^{(P_{\text{Target}} - P_{\text{Measured}})/10}$$

Where P_{Target} is the power of manufacturing upper limit;

P_{Measured} is the measured power in chapter 11.

Table 14.1: Duty Cycle

AP OFF	Duty Cycle
Speech for GSM850/1900	1:8.3
GPRS&EGPRS for GSM850/1900	1:8.3
WCDMA850/1900<E&WiFi	1:1
AP ON	Duty Cycle
GPRS for GSM1900	1:4
EGPRS for GSM1900	1:2
WCDMA1900<E	1:1

14.1 SAR results for Fast SAR

Table 14.2: SAR Values (GSM 850 MHz Band - Head) – AP OFF

Frequency		Side	Test Position	Figure No.	Ambient Temperature: 22.6°C		Liquid Temperature: 22.1°C			Power Drift (dB)
MHz	Ch.				Conducted Power (dBm)	Measured SAR(10g) (W/kg)	Reported SAR(10g) (W/kg)	Measured SAR(1g) (W/kg)	Reported SAR(1g) (W/kg)	
848.8	251	Left	Touch	/	33.70	0.440	0.47	0.554	0.59	0.09
836.6	190	Left	Touch	Fig.1	33.65	0.391	0.42	0.567	0.61	0.12
824.2	128	Left	Touch	/	33.58	0.328	0.36	0.478	0.53	-0.04
836.6	190	Left	Tilt	/	33.65	0.227	0.25	0.325	0.35	-0.02
848.8	251	Right	Touch	/	33.70	0.418	0.45	0.560	0.60	-0.12
836.6	190	Right	Touch	/	33.65	0.392	0.42	0.557	0.60	-0.10
824.2	128	Right	Touch	/	33.58	0.344	0.38	0.488	0.54	0.18
836.6	190	Right	Tilt	/	33.65	0.234	0.25	0.333	0.36	-0.01

Table 14.3: SAR Values (GSM 850 MHz Band - Body) – AP OFF

Frequency		Mode (number of timeslots)	Test Position	Figure No.	Ambient Temperature: 22.6 °C		Liquid Temperature: 22.1 °C			Power Drift (dB)
MHz	Ch.				Conducted Power (dBm)	Measured SAR(10g) (W/kg)	Reported SAR(10g) (W/kg)	Measured SAR(1g) (W/kg)	Reported SAR(1g) (W/kg)	
848.8	251	GPRS (1)	Front	/	33.70	0.523	0.56	0.679	0.73	-0.19
836.6	190	GPRS (1)	Front	Fig.2	33.68	0.594	0.64	0.770	0.83	0.01
824.2	128	GPRS (1)	Front	/	33.57	0.585	0.65	0.749	0.83	-0.09
836.6	190	GPRS (1)	Rear	/	33.68	0.463	0.50	0.609	0.66	-0.10
836.6	190	GPRS (1)	Left	/	33.68	0.377	0.41	0.535	0.58	-0.10
836.6	190	GPRS (1)	Right	/	33.68	0.344	0.37	0.498	0.54	0.13
836.6	190	GPRS (1)	Bottom	/	33.68	0.142	0.15	0.265	0.29	-0.19
836.6	190	EGPRS (1)	Front	/	33.66	0.587	0.63	0.759	0.82	-0.03
836.6	190	Speech	Front (Headset)	/	33.65	0.434	0.47	0.555	0.60	-0.04

Note1: The distance between the EUT and the phantom bottom is 10mm for data and 15mm for speech.

Note2: The type of Headset is MH410c

Table 14.4: SAR Values (GSM 1900 MHz Band - Head) – AP OFF

Frequency		Side	Test Position	Figure No.	Ambient Temperature: 22.7 °C		Liquid Temperature: 22.2 °C			Power Drift (dB)
MHz	Ch.				Conducted Power (dBm)	Measured SAR(10g) (W/kg)	Reported SAR(10g) (W/kg)	Measured SAR(1g) (W/kg)	Reported SAR(1g) (W/kg)	
1909.8	810	Left	Touch	/	30.61	0.135	0.15	0.229	0.25	0.02
1880	661	Left	Touch	/	30.62	0.139	0.15	0.234	0.26	-0.02
1850.2	512	Left	Touch	Fig.3	30.73	0.175	0.19	0.278	0.30	0.15
1880	661	Left	Tilt	/	30.62	0.054	0.06	0.093	0.10	0.07
1909.8	810	Right	Touch	/	30.61	0.145	0.16	0.242	0.26	-0.13
1880	661	Right	Touch	/	30.62	0.162	0.18	0.277	0.30	0.18
1850.2	512	Right	Touch	/	30.73	0.146	0.16	0.252	0.27	-0.14
1880	661	Right	Tilt	/	30.62	0.087	0.09	0.146	0.16	0.10

Table 14.5: SAR Values (GSM 1900 MHz Band - Body) – AP ON

Frequency		Mode (number of timeslots)	Test Position	Figure No.	Ambient Temperature: 22.7 °C		Liquid Temperature: 22.2 °C			Power Drift (dB)
MHz	Ch.				Conducted Power (dBm)	Measured SAR(10g) (W/kg)	Reported SAR(10g) (W/kg)	Measured SAR(1g) (W/kg)	Reported SAR(1g) (W/kg)	
1880	661	GPRS (2)	Front	/	24.93	0.354	0.45	0.654	0.84	0.06
1880	661	GPRS (2)	Rear	/	24.93	0.168	0.21	0.277	0.35	-0.09
1880	661	GPRS (2)	Left	/	24.93	0.036	0.05	0.060	0.08	-0.02
1880	661	GPRS (2)	Right	/	24.93	0.024	0.03	0.039	0.05	-0.08
1909.8	810	GPRS (2)	Bottom	/	24.75	0.395	0.53	0.754	1.01	0.01
1880	661	GPRS (2)	Bottom	/	24.93	0.425	0.54	0.805	1.03	-0.06

1850.2	512	GPRS (2)	Bottom	/	25.05	0.424	0.53	0.794	0.99	0.01
1909.8	810	EGPRS (4)	Bottom	/	21.79	0.367	0.48	0.705	0.93	0.11
1880	661	EGPRS (4)	Bottom	Fig.4	21.85	0.429	0.56	0.809	1.05	0.15
1850.2	512	EGPRS (4)	Bottom	/	21.94	0.397	0.51	0.749	0.96	0.00

Note1: The distance between the EUT and the phantom bottom is 10mm.

Table 14.6: SAR Values (GSM 1900 MHz Band - Body) – AP OFF

Ambient Temperature: 22.7 °C					Liquid Temperature: 22.2 °C					
Frequency		Mode (number of timeslots)	Test Position	Figure No.	Conducted Power (dBm)	Measured SAR(10g) (W/kg)	Reported SAR(10g) (W/kg)	Measured SAR(1g) (W/kg)	Reported SAR(1g) (W/kg)	Power Drift (dB)
MHz	Ch.									
1909.8	810	GPRS (1)	Front	Fig.5	30.59	0.411	0.45	0.704	0.77	0.10
1880	661	GPRS (1)	Front	/	30.61	0.383	0.42	0.656	0.72	0.01
1850.2	512	GPRS (1)	Front	/	30.72	0.390	0.42	0.680	0.73	0.04
1880	661	GPRS (1)	Rear	/	30.61	0.213	0.23	0.342	0.37	0.05
1909.8	810	EGPRS (1)	Front	/	30.53	0.382	0.43	0.686	0.76	0.09
1909.8	810	Speech	Front (Headset)	/	30.61	0.396	0.43	0.677	0.74	-0.02

Note1: The distance between the EUT and the phantom bottom is 15mm.

Note2: The type of Headset is MH410c

Table 14.7: SAR Values (WCDMA 850 MHz Band - Head) – AP OFF

Ambient Temperature: 22.6 °C					Liquid Temperature: 22.1 °C					
Frequency		Side	Test Position	Figure No.	Conducted Power (dBm)	Measured SAR(10g) (W/kg)	Reported SAR(10g) (W/kg)	Measured SAR(1g) (W/kg)	Reported SAR(1g) (W/kg)	Power Drift (dB)
MHz	Ch.									
846.6	4233	Left	Touch	Fig.6	24.54	0.392	0.41	0.500	0.52	0.17
836.4	4182	Left	Touch	/	24.62	0.324	0.33	0.468	0.48	-0.16
826.4	4132	Left	Touch	/	24.66	0.300	0.30	0.437	0.44	0.05
836.4	4182	Left	Tilt	/	24.62	0.171	0.17	0.245	0.25	0.01
846.6	4233	Right	Touch	/	24.54	0.345	0.36	0.463	0.48	0.07
836.4	4182	Right	Touch	/	24.62	0.308	0.31	0.440	0.45	-0.09
826.4	4132	Right	Touch	/	24.66	0.282	0.28	0.402	0.41	0.11
836.4	4182	Right	Tilt	/	24.62	0.194	0.20	0.274	0.28	-0.03

Table 14.8: SAR Values (WCDMA 850 MHz Band - Body) – AP OFF

Ambient Temperature: 22.6 °C					Liquid Temperature: 22.1 °C					
Frequency		Test Position	Figure No.	Conducted Power (dBm)	Measured SAR(10g) (W/kg)	Reported SAR(10g) (W/kg)	Measured SAR(1g) (W/kg)	Reported SAR(1g) (W/kg)	Power Drift (dB)	
MHz	Ch.									
846.6	4233	Front	/	24.54	0.515	0.53	0.666	0.69	0.02	
836.4	4182	Front	/	24.62	0.532	0.54	0.679	0.69	0.01	
826.4	4132	Front	Fig.7	24.66	0.541	0.55	0.685	0.69	0.03	

836.4	4182	Rear	/	24.62	0.421	0.43	0.549	0.56	-0.07
836.4	4182	Left	/	24.62	0.342	0.35	0.487	0.50	-0.03
836.4	4182	Right	/	24.62	0.369	0.38	0.536	0.55	0.02
836.4	4182	Bottom	/	24.62	0.123	0.13	0.225	0.23	-0.02
836.4	4182	Front (Headset)	/	24.66	0.376	0.38	0.483	0.49	0.02

Note1: The distance between the EUT and the phantom bottom is 10mm for data and 15mm for speech.

Note2: The type of Headset is MH410c

Table 14.9: SAR Values (WCDMA 1900 MHz Band - Head) – AP OFF

Frequency		Side	Test Position	Figure No.	Ambient Temperature: 22.7 °C		Liquid Temperature: 22.2 °C			Power Drift (dB)
MHz	Ch.				Conducted Power (dBm)	Measured SAR(10g) (W/kg)	Reported SAR(10g) (W/kg)	Measured SAR(1g) (W/kg)	Reported SAR(1g) (W/kg)	
1907.6	9538	Left	Touch	Fig.8	23.68	0.327	0.33	0.521	0.52	0.17
1880	9400	Left	Touch	/	23.62	0.223	0.23	0.374	0.38	-0.08
1852.4	9262	Left	Touch	/	23.68	0.236	0.24	0.393	0.39	0.10
1880	9400	Left	Tilt	/	23.62	0.084	0.09	0.144	0.15	-0.11
1907.6	9538	Right	Touch	/	23.68	0.277	0.28	0.470	0.47	-0.19
1880	9400	Right	Touch	/	23.62	0.200	0.20	0.341	0.35	0.16
1852.4	9262	Right	Touch	/	23.68	0.194	0.19	0.333	0.33	0.18
1880	9400	Right	Tilt	/	23.62	0.130	0.13	0.218	0.22	0.06

Table 14.10: SAR Values (WCDMA 1900 MHz Band - Body) – AP ON

Frequency		Test Position	Figure No.	Ambient Temperature: 22.7 °C		Liquid Temperature: 22.2 °C			Power Drift (dB)
MHz	Ch.			Conducted Power (dBm)	Measured SAR(10g) (W/kg)	Reported SAR(10g) (W/kg)	Measured SAR(1g) (W/kg)	Reported SAR(1g) (W/kg)	
1907.6	9538	Front	/	19.39	0.534	0.55	0.988	1.01	0.02
1880	9400	Front	/	19.43	0.445	0.45	0.826	0.84	0.06
1852.4	9262	Front	/	19.50	0.364	0.36	0.670	0.67	-0.10
1880	9400	Rear	/	19.43	0.217	0.22	0.362	0.37	0.15
1880	9400	Left	/	19.43	0.038	0.04	0.063	0.06	0.14
1880	9400	Right	/	19.43	0.027	0.03	0.044	0.05	-0.07
1907.6	9538	Bottom	Fig.9	19.39	0.541	0.55	1.03	1.06	-0.04
1880	9400	Bottom	/	19.43	0.471	0.48	0.890	0.90	0.02
1852.4	9262	Bottom	/	19.50	0.436	0.44	0.824	0.82	0.03

Note1: The distance between the EUT and the phantom bottom is 10mm.

Table 14.11: SAR Values (WCDMA 1900 MHz Band - Body) – AP OFF

Frequency		Test Position	Figure No.	Conducted Power (dBm)	Measured SAR(10g) (W/kg)	Reported SAR(10g) (W/kg)	Measured SAR(1g) (W/kg)	Reported SAR(1g) (W/kg)	Power Drift (dB)	
MHz	Ch.									
Ambient Temperature: 22.7°C		Liquid Temperature: 22.2°C								
1907.6	9538	Front	Fig.10	23.68	0.767	0.77	1.32	1.33	-0.09	
1880	9400	Front	/	23.62	0.636	0.65	1.09	1.11	-0.06	
1852.4	9262	Front	/	23.68	0.683	0.69	1.15	1.16	-0.01	
1880	9400	Rear	/	23.62	0.323	0.33	0.514	0.52	0.04	
1907.6	9538	Front (Headset)	Fig.11	23.68	0.766	0.77	1.3	1.31	-0.00	
1880	9400	Front (Headset)	/	23.62	0.644	0.66	1.09	1.11	-0.00	
1852.4	9262	Front (Headset)	/	23.68	0.661	0.66	1.1	1.11	0.04	

Note1: The distance between the EUT and the phantom bottom is 15mm.

Note2: The type of Headset1 is MH410c

Table 14.12: SAR Values (LTE Band2 - Head) – AP OFF

Frequency		Mode	Side	Test Position	Figure No.	Conducted Power (dBm)	Measured SAR(10g) (W/kg)	Reported SAR(10g) (W/kg)	Measured SAR(1g) (W/kg)	Reported SAR(1g) (W/kg)	Power Drift (dB)
MHz	Ch.										
Ambient Temperature: 22.7°C		Liquid Temperature: 22.2°C									
1880	18900	1RB_Middle	Left	Touch	/	22.88	0.211	0.23	0.340	0.37	-0.11
1880	18900	1RB_Middle	Left	Tilt	/	22.88	0.061	0.07	0.103	0.11	-0.16
1880	18900	1RB_Middle	Right	Touch	Fig.12	22.88	0.214	0.23	0.371	0.40	-0.12
1880	18900	1RB_Middle	Right	Tilt	/	22.88	0.092	0.10	0.156	0.17	-0.19
1860	18700	50RB_High	Left	Touch	/	21.92	0.229	0.31	0.368	0.49	0.17
1860	18700	50RB_High	Left	Tilt	/	21.92	0.058	0.08	0.098	0.13	-0.19
1860	18700	50RB_High	Right	Touch	/	21.92	0.201	0.27	0.350	0.47	-0.06
1860	18700	50RB_High	Right	Tilt	/	21.92	0.092	0.12	0.156	0.21	0.10

Note1: The LTE mode is QPSK_20MHz.

Table 14.13: SAR Values (LTE Band2 - Body) – AP ON

Frequency		Mode	Test Position	Figure No.	Conducted Power (dBm)	Measured SAR(10g) (W/kg)	Reported SAR(10g) (W/kg)	Measured SAR(1g) (W/kg)	Reported SAR(1g) (W/kg)	Power Drift (dB)
MHz	Ch.									
Ambient Temperature: 22.7°C		Liquid Temperature: 22.2°C								
1900	19100	1RB_Midle	Front	/	18.58	0.435	0.54	0.806	1.00	-0.04
1880	18900	1RB_Midle	Front	/	18.86	0.429	0.50	0.791	0.92	0.14
1860	18700	1RB_Midle	Front	/	19.09	0.474	0.52	0.867	0.95	-0.06
1860	18700	1RB_Midle	Rear	/	19.09	0.247	0.27	0.396	0.44	-0.10
1860	18700	1RB_Midle	Left	/	19.09	0.053	0.06	0.087	0.10	0.09

1860	18700	1RB_Midle	Right	/	19.09	0.024	0.03	0.040	0.04	-0.13
1900	19100	1RB_Midle	Bottom	/	18.58	0.418	0.52	0.795	0.98	0.03
1880	18900	1RB_Midle	Bottom	/	18.86	0.395	0.46	0.760	0.88	0.10
1860	18700	1RB_Midle	Bottom	/	19.09	0.446	0.49	0.847	0.93	0.19
1900	19100	50RB_Low	Front	/	18.71	0.333	0.40	0.613	0.74	-0.16
1880	18900	50RB_Low	Front	/	19.11	0.432	0.47	0.789	0.86	0.10
1860	18700	50RB_Low	Front	Fig.13	18.91	0.534	0.61	1	1.15	0.10
1880	18900	50RB_Low	Rear	/	19.11	0.221	0.24	0.364	0.40	-0.10
1880	18900	50RB_Low	Left	/	19.11	0.041	0.05	0.068	0.07	-0.14
1880	18900	50RB_Low	Right	/	19.11	0.021	0.02	0.035	0.04	0.00
1900	19100	50RB_Low	Bottom	/	18.71	0.452	0.54	0.853	1.02	-0.16
1880	18900	50RB_Low	Bottom	/	19.11	0.426	0.47	0.805	0.88	0.03
1860	18700	50RB_Low	Bottom	/	18.91	0.426	0.49	0.809	0.93	0.11
1860	18700	100RB	Front	/	19.06	0.432	0.48	0.817	0.90	-0.09

Note1: The distance between the EUT and the phantom bottom is 10mm.

Note2: The LTE mode is QPSK_20MHz.

Table 14.14: SAR Values (LTE Band2 - Body) – AP OFF

Frequency		Mode	Test Position	Figure No.	Ambient Temperature: 22.7°C		Liquid Temperature: 22.2°C			Power Drift (dB)
MHz	Ch.				Conducted Power (dBm)	Measured SAR(10g) (W/kg)	Reported SAR(10g) (W/kg)	Measured SAR(1g) (W/kg)	Reported SAR(1g) (W/kg)	
1900	19100	1RB_Midle	Front	/	22.68	0.526	0.59	0.906	1.02	0.04
1880	18900	1RB_Midle	Front	/	22.88	0.560	0.60	0.959	1.03	0.03
1860	18700	1RB_Midle	Front	Fig.14	22.77	0.669	0.74	1.12	1.24	-0.00
1880	18900	1RB_Midle	Rear	/	22.88	0.384	0.41	0.606	0.65	0.10
1900	19100	50RB_High	Front	/	21.67	0.445	0.63	0.770	1.10	0.11
1880	18900	50RB_High	Front	/	21.79	0.433	0.60	0.745	1.03	0.11
1860	18700	50RB_High	Front	/	21.92	0.524	0.70	0.889	1.19	-0.03
1860	18700	50RB_High	Rear	/	21.92	0.296	0.40	0.469	0.63	-0.09
1860	18700	100RB	Front	/	21.81	0.508	0.70	0.860	1.18	0.01

Note1: The distance between the EUT and the phantom bottom is 15mm.

Note2: The LTE mode is QPSK_20MHz.

Table 14.15: SAR Values (LTE Band4 - Head) – AP OFF

Frequency		Mode	Side	Test Position	Figure No.	Ambient Temperature: 22.8°C		Liquid Temperature: 22.3°C			Power Drift (dB)
MHz	Ch.					Conducte d Power (dBm)	Measured SAR(10g) (W/kg)	Reported SAR(10g) (W/kg)	Measured SAR(1g) (W/kg)	Reported SAR(1g) (W/kg)	
1732.5	20175	1RB_Middle	Left	Touch	/	24.00	0.415	0.42	0.641	0.64	0.16
1732.5	20175	1RB_Middle	Left	Tilt	/	24.00	0.107	0.11	0.179	0.18	-0.04
1732.5	20175	1RB_Middle	Right	Touch	Fig.15	24.00	0.384	0.38	0.656	0.66	-0.12
1732.5	20175	1RB_Middle	Right	Tilt	/	24.00	0.180	0.18	0.307	0.31	-0.00

1732.5	20175	50RB_Middle	Left	Touch	/	22.62	0.306	0.42	0.472	0.65	0.09
1732.5	20175	50RB_Middle	Left	Tilt	/	22.62	0.079	0.11	0.132	0.18	-0.18
1732.5	20175	50RB_Middle	Right	Touch	/	22.62	0.284	0.39	0.488	0.67	0.19
1732.5	20175	50RB_Middle	Right	Tilt	/	22.62	0.133	0.18	0.227	0.31	-0.10

Note1: The LTE mode is QPSK_20MHz.

Table 14.16: SAR Values (LTE Band4 - Body) – AP ON

Frequency		Mode	Test Position	Figure No.	Ambient Temperature: 22.8°C		Liquid Temperature: 22.3°C			Power Drift (dB)
MHz	Ch.				Conducted Power (dBm)	Measured SAR(10g) (W/kg)	Reported SAR(10g) (W/kg)	Measured SAR(1g) (W/kg)	Reported SAR(1g) (W/kg)	
1745	20300	1RB_Low	Front	Fig.16	19.81	0.588	0.61	1.1	1.15	0.01
1732.5	20175	1RB_Low	Front	/	19.51	0.469	0.53	0.864	0.97	-0.08
1720	20050	1RB_Low	Front	/	19.51	0.369	0.41	0.659	0.74	-0.04
1745	20300	1RB_Low	Rear	/	19.81	0.310	0.32	0.507	0.53	0.15
1745	20300	1RB_Low	Left	/	19.81	0.638	0.67	0.105	0.11	0.01
1745	20300	1RB_Low	Right	/	19.81	0.018	0.02	0.031	0.03	0.03
1745	20300	1RB_Low	Bottom	/	19.81	0.422	0.44	0.775	0.81	-0.06
1732.5	20175	1RB_Low	Bottom	/	19.51	0.336	0.38	0.645	0.72	0.01
1720	20050	1RB_Low	Bottom	/	19.51	0.296	0.33	0.570	0.64	-0.10
1745	20300	50RB_Middle	Front	/	19.50	0.502	0.56	0.944	1.06	-0.04
1732.5	20175	50RB_Middle	Front	/	19.65	0.535	0.58	1	1.08	0.04
1720	20050	50RB_Middle	Front	/	19.38	0.419	0.48	0.785	0.91	0.05
1732.5	20175	50RB_Middle	Rear	/	19.65	0.277	0.30	0.456	0.49	-0.00
1732.5	20175	50RB_Middle	Left	/	19.65	0.078	0.08	0.130	0.14	-0.11
1732.5	20175	50RB_Middle	Right	/	19.65	0.015	0.02	0.027	0.03	0.10
1732.5	20175	50RB_Middle	Bottom	/	19.65	0.377	0.41	0.690	0.75	-0.09
1732.5	20175	100RB	Front	/	19.51	0.336	0.38	0.566	0.63	0.07

Note1: The distance between the EUT and the phantom bottom is 10mm.

Note2: The LTE mode is QPSK_20MHz.

Table 14.17: SAR Values (LTE Band4 - Body) – AP OFF

Frequency		Mode	Test Position	Figure No.	Ambient Temperature: 22.8°C		Liquid Temperature: 22.3°C			Power Drift (dB)
MHz	Ch.				Conducted Power (dBm)	Measured SAR(10g) (W/kg)	Reported SAR(10g) (W/kg)	Measured SAR(1g) (W/kg)	Reported SAR(1g) (W/kg)	
1745	20300	1RB_Middle	Front	/	23.82	0.492	0.51	0.797	0.83	-0.11
1732.5	20175	1RB_Middle	Front	Fig.17	24.00	0.554	0.55	0.880	0.88	0.12
1720	20050	1RB_Middle	Front	/	23.74	0.404	0.43	0.646	0.69	0.02
1732.5	20175	1RB_Middle	Rear	/	24.00	0.482	0.48	0.751	0.75	0.01
1745	20300	50RB_Middle	Front	/	22.41	0.487	0.70	0.791	1.14	-0.10
1732.5	20175	50RB_Middle	Front	/	22.62	0.419	0.58	0.668	0.92	0.02
1720	20050	50RB_Middle	Front	/	22.36	0.377	0.55	0.623	0.91	0.12

1732.5	20175	50RB_Middle	Rear	/	22.62	0.357	0.49	0.556	0.76	0.13
1732.5	20175	100RB	Front	/	22.58	0.468	0.65	0.764	1.06	0.09

Note1: The distance between the EUT and the phantom bottom is 15mm.

Note2: The LTE mode is QPSK_20MHz.

Table 14.18: SAR Values (LTE Band5 - Head) – AP OFF

Frequency		Mode	Side	Test Position	Figure No.	Ambient Temperature: 22.6 °C		Liquid Temperature: 22.1 °C			Power Drift (dB)
MHz	Ch.					Conducted Power (dBm)	Measured SAR(10g) (W/kg)	Reported SAR(10g) (W/kg)	Measured SAR(1g) (W/kg)	Reported SAR(1g) (W/kg)	
836.5	20525	1RB_High	Left	Touch	Fig.18	23.81	0.364	0.38	0.460	0.48	-0.10
836.5	20525	1RB_High	Left	Tilt	/	23.81	0.149	0.16	0.214	0.22	-0.03
836.5	20525	1RB_High	Right	Touch	/	23.81	0.322	0.34	0.422	0.44	-0.18
836.5	20525	1RB_High	Right	Tilt	/	23.81	0.165	0.17	0.237	0.25	-0.03
836.5	20525	25RB_High	Left	Touch	/	22.54	0.256	0.36	0.369	0.52	0.09
836.5	20525	25RB_High	Left	Tilt	/	22.54	0.114	0.16	0.164	0.23	-0.06
836.5	20525	25RB_High	Right	Touch	/	22.54	0.211	0.30	0.308	0.43	0.12
836.5	20525	25RB_High	Right	Tilt	/	22.54	0.127	0.18	0.181	0.25	-0.03

Note1: The LTE mode is QPSK_10MHz.

Table 14.19: SAR Values (LTE Band5 - Body) – AP OFF

Frequency		Mode	Test Position	Figure No.	Ambient Temperature: 22.6 °C		Liquid Temperature: 22.1 °C			Power Drift (dB)
MHz	Ch.				Conducted Power (dBm)	Measured SAR(10g) (W/kg)	Reported SAR(10g) (W/kg)	Measured SAR(1g) (W/kg)	Reported SAR(1g) (W/kg)	
836.5	20525	1RB_High	Front	Fig.19	23.81	0.392	0.41	0.503	0.53	-0.04
836.5	20525	1RB_High	Rear	/	23.81	0.319	0.33	0.428	0.45	-0.03
836.5	20525	1RB_High	Left	/	23.81	0.278	0.29	0.398	0.42	0.01
836.5	20525	1RB_High	Right	/	23.81	0.190	0.20	0.276	0.29	-0.16
836.5	20525	1RB_High	Bottom	/	23.81	0.105	0.11	0.194	0.20	-0.04
836.5	20525	25RB_High	Front	/	22.54	0.303	0.42	0.387	0.54	0.01
836.5	20525	25RB_High	Rear	/	22.54	0.248	0.35	0.329	0.46	-0.02
836.5	20525	25RB_High	Left	/	22.54	0.215	0.30	0.309	0.43	0.11
836.5	20525	25RB_High	Right	/	22.54	0.193	0.27	0.280	0.39	0.02
836.5	20525	25RB_High	Bottom	/	22.54	0.090	0.13	0.148	0.21	0.13

Note1: The distance between the EUT and the phantom bottom is 10mm.

Note2: The LTE mode is QPSK_10MHz.

Table 14.20: SAR Values (Wi-Fi 802.11b - Head) – AP OFF

Frequency		Side	Test Position	Figure No.	Ambient Temperature: 22.5 °C		Liquid Temperature: 22.0 °C			Power Drift (dB)
MHz	Ch.				Conducted Power (dBm)	Measured SAR(10g) (W/kg)	Reported SAR(10g) (W/kg)	Measured SAR(1g) (W/kg)	Reported SAR(1g) (W/kg)	
2437	6	Left	Touch	/	14.95	0.027	0.03	0.054	0.07	0.09
2437	6	Left	Tilt	/	14.95	0.00679	0.01	0.026	0.03	-0.08
2462	11	Right	Touch	/	15.08	0.079	0.10	0.171	0.21	-0.05
2437	6	Right	Touch	Fig.20	14.95	0.088	0.11	0.177	0.23	-0.03
2412	1	Right	Touch	/	15.26	0.064	0.08	0.142	0.17	-0.04
2437	6	Right	Tilt	/	14.95	0.034	0.04	0.071	0.09	0.11

Table 14.21: SAR Values (Wi-Fi 802.11b - Body) – AP OFF

Frequency		Test Position	Figure No.	Ambient Temperature: 22.5 °C		Liquid Temperature: 22.0 °C			Power Drift (dB)
MHz	Ch.			Conducted Power (dBm)	Measured SAR(10g) (W/kg)	Reported SAR(10g) (W/kg)	Measured SAR(1g) (W/kg)	Reported SAR(1g) (W/kg)	
2437	6	Front	/	14.95	0.013	0.02	0.024	0.03	-0.10
2462	11	Rear	Fig.21	15.08	0.039	0.05	0.104	0.13	-0.18
2437	6	Rear	/	14.95	0.024	0.03	0.067	0.09	-0.15
2412	1	Rear	/	15.26	0.027	0.03	0.072	0.09	-0.07
2437	6	Left	/	14.95	0.020	0.03	0.041	0.05	-0.19
2437	6	Top	/	14.95	0.00795	0.01	0.017	0.02	0.01

Note1: The distance between the EUT and the phantom bottom is 10mm.

Table 14.22: SAR Values (Wi-Fi 802.11a - Head) – AP OFF

Frequency		Side	Test Position	Figure No.	Ambient Temperature: 22.5 °C		Liquid Temperature: 22.0 °C			Power Drift (dB)
MHz	Ch.				Conducted Power (dBm)	Measured SAR(10g) (W/kg)	Reported SAR(10g) (W/kg)	Measured SAR(1g) (W/kg)	Reported SAR(1g) (W/kg)	
5745	149	Left	Touch	/	12.93	0.00898	0.01	0.030	0.03	0.11
5765	153	Left	Touch	Fig.22	12.93	0.014	0.01	0.050	0.05	0.18
5745	149	Right	Touch	/	12.93	0.00623	0.01	0.031	0.03	-0.08
5765	153	Right	Touch	/	12.93	0.00493	0.01	0.032	0.03	0.19
5765	153	Left	Tilt	/	12.93	0.00685	0.01	0.010	0.01	-0.08
5200	40	Left	Touch	/	12.54	0.00847	0.01	0.036	0.04	0.18
5260	52	Left	Touch	/	12.64	0.00809	0.01	0.035	0.04	0.15
5540	108	Left	Touch	/	12.84	0.011	0.01	0.049	0.05	-0.16

Table 14.23: SAR Values (Wi-Fi 802.11a - Body) – AP OFF

Frequency		Test Position	Figure No.	Conducted Power (dBm)	Measured SAR(10g) (W/kg)	Reported SAR(10g) (W/kg)	Measured SAR(1g) (W/kg)	Reported SAR(1g) (W/kg)	Power Drift (dB)
MHz	Ch.								
Ambient Temperature: 22.5 °C		Liquid Temperature: 22.0 °C							
5745	149	Rear	/	12.93	0.026	0.03	0.092	0.09	-0.13
5765	153	Rear	Fig.23	12.93	0.027	0.03	0.097	0.10	0.06
5765	153	Front	/	12.93	0.00206	0.00	0.00388	0.00	0.05
5765	153	Left	/	12.93	0.000652	0.00	0.00122	0.00	0.18
5765	153	Top	/	12.93	0.0012	0.00	0.00226	0.00	0.19
5200	40	Rear	/	12.54	0.0292	0.03	0.0526	0.06	0.17
5260	52	Rear	/	12.64	0.03	0.03	0.064	0.07	-0.19
5540	108	Rear	/	12.84	0.0357	0.04	0.0553	0.06	0.17

Note1: The distance between the EUT and the phantom bottom is 10mm.

Note2: For the test channel 40&108 of 802.11a, the maximum average output channel in each frequency band did not occur in the “default test channels” (table KDB 248227), so the maximum required test channels were tested instead of an adjacent “default test channel”.

Table 14.24: SAR Values (Wi-Fi 802.11n - Head) – AP OFF

Frequency		Side	Test Position	Figure No.	Conducted Power (dBm)	Measured SAR(10g) (W/kg)	Reported SAR(10g) (W/kg)	Measured SAR(1g) (W/kg)	Reported SAR(1g) (W/kg)	Power Drift (dB)
MHz	Ch.									
Ambient Temperature: 22.5 °C		Liquid Temperature: 22.0 °C								
5765	153	Left	Touch	/	13.00	0.00813	0.01	0.032	0.03	0.12
5765	153	Left	Tilt	/	13.00	0.00214	0.00	0.00523	0.01	-0.01
5765	153	Right	Touch	/	13.00	0.00343	0.00	0.022	0.02	0.16
5765	153	Right	Tilt	/	13.00	0.00158	0.00	0.00221	0.00	0.14
5180	36	Left	Touch	/	12.82	0.010	0.01	0.033	0.03	0.16
5260	52	Left	Touch	/	12.84	0.012	0.01	0.036	0.04	0.18
5580	116	Left	Touch	Fig.24	12.78	0.014	0.01	0.038	0.04	0.18

Table 14.25: SAR Values (Wi-Fi 802.11n - Body) – AP OFF

Frequency		Test Position	Figure No.	Conducted Power (dBm)	Measured SAR(10g) (W/kg)	Reported SAR(10g) (W/kg)	Measured SAR(1g) (W/kg)	Reported SAR(1g) (W/kg)	Power Drift (dB)
MHz	Ch.								
Ambient Temperature: 22.5 °C		Liquid Temperature: 22.0 °C							
5765	153	Front	/	13.00	0.000902	0.00	0.0017	0.00	-0.19
5765	153	Rear	/	13.00	0.00941	0.01	0.054	0.05	-0.17
5765	153	Left	/	13.00	0.00438	0.00	0.00637	0.01	0.18
5765	153	Top	/	13.00	0.0034	0.00	0.00542	0.01	0.19
5180	36	Rear	/	12.82	0.015	0.02	0.056	0.06	-0.15
5260	52	Rear	/	12.84	0.028	0.03	0.066	0.07	0.16
5580	116	Rear	Fig.25	12.78	0.029	0.03	0.07	0.07	0.18

Note1: The distance between the EUT and the phantom bottom is 10mm.

14.2 SAR results for Standard procedure

There is zoom scan measurement to be added for the highest measured SAR in each exposure configuration/band and the SAR values that are > 1.2 W/kg.

Table 14.26: SAR Values (GSM 850 MHz Band - Head) – AP OFF

Frequency		Side	Test Position	Figure No.	Ambient Temperature: 22.6 °C		Liquid Temperature: 22.1 °C			Power Drift (dB)
MHz	Ch.				Conducted Power (dBm)	Measured SAR(10g) (W/kg)	Reported SAR(10g) (W/kg)	Measured SAR(1g) (W/kg)	Reported SAR(1g) (W/kg)	
836.6	190	Left	Touch	Fig.1	33.65	0.391	0.42	0.567	0.61	0.12

Table 14.27: SAR Values (GSM 850 MHz Band - Body) – AP OFF

Frequency		Mode (number of timeslots)	Test Position	Figure No.	Ambient Temperature: 22.6 °C		Liquid Temperature: 22.1 °C			Power Drift (dB)
MHz	Ch.				Conducted Power (dBm)	Measured SAR(10g) (W/kg)	Reported SAR(10g) (W/kg)	Measured SAR(1g) (W/kg)	Reported SAR(1g) (W/kg)	
836.6	190	GPRS (1)	Front	Fig.2	33.68	0.594	0.64	0.770	0.83	0.01

Note1: The distance between the EUT and the phantom bottom is 10mm.

Table 14.28: SAR Values (GSM 1900 MHz Band - Head) – AP OFF

Frequency		Side	Test Position	Figure No.	Ambient Temperature: 22.7 °C		Liquid Temperature: 22.2 °C			Power Drift (dB)
MHz	Ch.				Conducted Power (dBm)	Measured SAR(10g) (W/kg)	Reported SAR(10g) (W/kg)	Measured SAR(1g) (W/kg)	Reported SAR(1g) (W/kg)	
1850.2	512	Left	Touch	Fig.3	30.73	0.175	0.19	0.278	0.30	0.15

Table 14.29: SAR Values (GSM 1900 MHz Band - Body) – AP ON

Frequency		Mode (number of timeslots)	Test Position	Figure No.	Ambient Temperature: 22.7 °C		Liquid Temperature: 22.2 °C			Power Drift (dB)
MHz	Ch.				Conducted Power (dBm)	Measured SAR(10g) (W/kg)	Reported SAR(10g) (W/kg)	Measured SAR(1g) (W/kg)	Reported SAR(1g) (W/kg)	
1880	661	EGPRS (4)	Bottom	Fig.4	21.85	0.429	0.56	0.809	1.05	0.15

Note1: The distance between the EUT and the phantom bottom is 10mm.

Table 14.30: SAR Values (GSM 1900 MHz Band - Body) – AP OFF

Frequency		Mode (number of timeslots)	Test Position	Figure No.	Ambient Temperature: 22.7 °C		Liquid Temperature: 22.2 °C			Power Drift (dB)
MHz	Ch.				Conducted Power (dBm)	Measured SAR(10g) (W/kg)	Reported SAR(10g) (W/kg)	Measured SAR(1g) (W/kg)	Reported SAR(1g) (W/kg)	
1909.8	810	GPRS (1)	Front	Fig.5	30.59	0.411	0.45	0.704	0.77	0.10

Note1: The distance between the EUT and the phantom bottom is 15mm.