



TEST REPORT

No. 130124IOT01FCC

for

Sony Mobile Communications (China) Co. Ltd

GSM/UMTS/LTE mobile phone

Type: PM-0350-BV

with

FCCID: PY7PM-0350

Hardware Version: A

Software Version: 12.0.A.1.18

Issued Date: April 26th, 2013



Note:

The test results in this test report relate only to the devices specified in this report. This report shall not be reproduced except in full without the written approval of TMC Beijing.

Test Laboratory:

CNAS accreditation (ISO/IEC 17025(CNAS-CL01)): No. CNAS L0442

FCC 2.948 Listed: No.733176

IC O.A.T.S listed: No.6629A-1

TMC Beijing, Telecommunication Metrology Center of Ministry of Industry and Information Technology

No. 52, Huayuanbei Road, Haidian District, Beijing, P. R. China 100191

Tel:+86-10-62304633; Fax:+86-10-62304633; Email:welcome@emcite.com; Http://www.emcite.com/

CONTENTS

1. TEST LABORATORY	3
1.1. TESTING LOCATION	3
1.2. TESTING ENVIRONMENT	3
1.3. PROJECT DATA	3
1.4. SIGNATURE	3
2. CLIENT INFORMATION	4
2.1. APPLICANT INFORMATION	4
2.2. MANUFACTURER INFORMATION	4
3. EQUIPMENT UNDER TEST (EUT) AND ANCILLARY EQUIPMENT (AE)	5
3.1. ABOUT EUT	5
3.2. INTERNAL IDENTIFICATION OF EUT USED DURING THE TEST	5
3.3. INTERNAL IDENTIFICATION OF AE USED DURING THE TEST	5
3.4. GENERAL DESCRIPTION	6
3.5. EUT SET-UPS	6
4. REFERENCE DOCUMENTS	7
4.1. DOCUMENTS SUPPLIED BY THE APPLICANT	7
4.2. REGULATIONS AND STANDARDS	7
5. LABORATORY ENVIRONMENT	8
6. SUMMARY OF TEST RESULTS	9
6.1. SUMMARY OF TEST RESULTS	9
6.2. TERMS USED IN THE SUMMARY OF TEST RESULTS	9
6.3. STATEMENTS	10
7. TEST EQUIPMENTS UTILIZED	11
ANNEX A: MEASUREMENT RESULTS	12
A.1. ELECTRIC FIELD STRENGTH OF FUNDAMENTAL AND OUTSIDE THE ALLOCATED BANDS	12
A.2. ELECTRIC FIELD RADIATED EMISSIONS (< 30MHz)	14
A.3. ELECTRIC FIELD RADIATED EMISSIONS (≥ 30 MHz)	16
A.4. FREQUENCY TOLERANCE	18
A.5. 20DB BANDWIDTH	19
A.6. CONDUCTED EMISSION	21

1. Test Laboratory

1.1. Testing Location

Company Name: TMC Beijing, Telecommunication Metrology Center of MIT
Address: No 52, Huayuanbei Road, Haidian District, Beijing, P.R.China
Postal Code: 100191
Telephone: +86-10-62304633-2678
Fax: +86-10-62304633-2504

1.2. Testing Environment

Ambient Temperature: 15 ~ 25 °C
Relative Humidity: 30 ~ 60 %
Air pressure 860 ~ 1060 mbar

1.3. Project Data

Receipt of Sample: Jan 24th, 2013
Testing Start Date: Jan 31st, 2013
Testing End Date: Feb 21st, 2013

1.4. Signature



Sun Qian

(Prepared this test report)

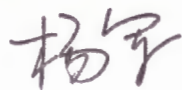

Yang Jun

(Reviewed this test report)

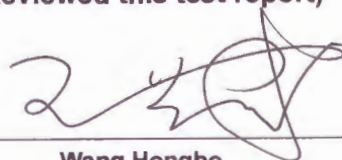

Wang Hongbo

Deputy Director of the laboratory

(Approved this test report)

2. Client Information

2.1. Applicant Information

Company Name: Sony Mobile Communications (China) Co. Ltd
Address /Post: Sony Mobile R&D Center, No. 16, Guangshun South Street,
Chaoyang District
City: Beijing
Postal Code: 100102
Country: China
Telephone: +86-10-58656312
Fax: +86-10-58659049

2.2. Manufacturer Information

Company Name: Sony Mobile Communications (China) Co. Ltd
Address /Post: Sony Mobile R&D Center, No. 16, Guangshun South Street,
Chaoyang District
City: Beijing
Postal Code: 100102
Country: China
Telephone: +86-10-58656312
Fax: +86-10-58659049

3. Equipment Under Test (EUT) and Ancillary Equipment (AE)

3.1. About EUT

Description:	GSM/UMTS/LTE mobile phone
Model Name:	PM-0350-BV
Marketing Name:	C5303
FCC ID:	PY7PM-0350
IC ID:	/
With NFC Function:	Yes
Frequency:	13.56 MHz
Antenna:	Integral Antenna
Operation Voltage:	DC 3.6 ~ 4.2 V
Operation Temperature:	-20 ~ 55 °C

Note1: Photographs of EUT are shown in ANNEX A of this test report. For component list, please refer to documents of the manufacturer.

Note2: High and low voltage values of extreme conditions are given by the manufacturer.

3.2. Internal Identification of EUT Used during the Test

Mobile phone identification

EUT ID*	SN / IMEI	HW Version	SW Version
#23572	004402450616465	A	12.0.A.1.18

*EUT ID: It is used to identify the test sample in the lab internally.

3.3. Internal Identification of AE Used during the Test

AE ID*	Description	SN	Revision
#23302	Travel Charger	8512W41509972	1
#22312	USB Cable	121607DA0001C72	SP1
AE3	Type A CARD	/	/

#23302

Type	EP880
Manufacturer	SALCOMP
Length of cable	/

#23312

Commercial name	EC801
Type	AI-0401
Manufacturer	Sony Mobile
Length of cable	96.5cm

AE3

Type	/
Manufacturer	Gemalto
Length of cable	/

*AE ID: is used to identify the test sample in the lab internally.

3.4. General Description

The Equipment Under Test (EUT) is a model of GSM/UMTS/LTE mobile phone with integrated antenna and inbuilt Li-Polymer battery.

The EUT supports GSM 850/900/1800/1900MHz bands, WCDMA FDD bands 1/5/8 and LTE FDD bands 1/3/5/7/8/20. It also supports GPRS service with multi-slots class 33 and EGPRS service with multi-slots class 33 too. The HSDPA and HSUPA features are also supported.

It has NFC, MP3, camera, FM radio, USB memory, GPS receiver, Mobile High-Definition Link (MHL), Bluetooth (EDR and Bluetooth 4.0), WLAN (802.11 a/b/g/n) and Wi-Fi hotspot function

Manuals and specifications of the EUT were provided to fulfil the test.

Samples undergoing test were selected by the client.

Manufacturer's declaration: NFC work does not depend on other access methods, such as WLAN, GPRS, etc.

3.5. EUT Set-ups

EUT Set-up No.	Combination of EUT and AE	Remarks
Set. NFC01	#23572+ #23302+ #22312+AE3(PICC)	--
Set. NFC02	#23572	--
Set. NFC03	#23572+AE3(PICC)	--

The Transmit State of NFC: the NFC function is on. The EUT will transmit the NFC data and command continuously during the test.

The Transmit State of without modulation: The EUT will transmit the CW signal at the operating frequency.

4. Reference Documents

4.1. Documents Supplied by the Applicant

EUT feature information is supplied by the applicant or manufacturer, which is the basis of testing.

4.2. Regulations and Standards

The following documents listed in this section are referred for testing.

Reference	Title	Version
CFR 47 Part 2	Part 2 — Frequency Allocations and Radio Treaty Matters; General Rules and Regulations.	2012
CFR 47 Part 15	Part 15 — Radio Frequency Devices. Subpart C — Intentional Radiators. § 15.207 Conducted limits. § 15.209 Radiated emission limits, general requirements. § 15.215 Additional provisions to the general radiated emission limitations. § 15.225 Operation within the band 13.110–14.010 MHz.	2012
ANSI C63.4	American National Standard for Methods of Measurement of Radio-Noise Emissions from Low-Voltage Electrical and Electronic Equipment in the Range of 9 kHz to 40 GHz.	2009

5. LABORATORY ENVIRONMENT

Semi-Anechoic Chamber SAC-2 (10m×6.7m×6.15m) did not exceed following limits along the testing:

Temperature	Min. = 15 °C, Max. = 25 °C
Relative humidity	Min. = 30 %, Max. = 60 %
Shielding effectiveness	> 110 dB
Electrical insulation	> 2 MΩ
Ground system resistance	< 1 Ω
Normalised site attenuation (NSA)	< ±3.5 dB, 3 m distance, from 30 to 1000 MHz
Site voltage standing-wave ratio (S_{VSWR})	Between 0 and 6 dB, from 1 to 18 GHz
Uniformity of field strength	Between 0 and 6 dB, from 80 to 3000 MHz

Fully-Anechoic Chamber FAC-3 (8.6m×6.1m×3.85m) did not exceed following limits along the testing:

Temperature	Min. = 15 °C, Max. = 25 °C
Relative humidity	Min. = 30 %, Max. = 60 %
Shielding effectiveness	> 110 dB
Electrical insulation	> 2 MΩ
Ground system resistance	< 1 Ω
Site voltage standing-wave ratio (S_{VSWR})	Between 0 and 6 dB, from 1 to 18GHz
Uniformity of field strength	Between 0 and 6 dB, from 80 to 4000 MHz

Conducted Chamber did not exceed following limits along the testing:

Temperature	Min. = 15 °C, Max. = 25 °C
Relative humidity	Min. = 30 %, Max. = 60 %
Shielding effectiveness	> 110 dB
Electrical insulation	> 2 MΩ
Ground system resistance	< 0.5 Ω

Control Room did not exceed following limits along the testing:

Temperature	Min. = 15 °C, Max. = 25 °C
Relative humidity	Min. =30 %, Max. = 60 %
Shielding effectiveness	> 110 dB
Electrical insulation	> 2 MΩ
Ground system resistance	< 0.5 Ω

6. SUMMARY OF TEST RESULTS

6.1. Summary of Test Results

No	Test Cases	Clause in Regulation	Section in This Report	Verdict
1	Electric Field Strength of Fundamental Emissions	CFR 47 § 15.225(a)	A.1	P(Set. NFC03)
2	Electric Field Strength of Outside the Allocated Bands	CFR 47 § 15.225(b) CFR 47 § 15.225(c)		P(Set. NFC03)
3	Electric Field Radiated Emissions	CFR 47 § 15.209	A.2	P(Set. NFC01)
		CFR 47 § 15.225(d)	A.3	P(Set. NFC01)
4	Frequency Tolerance	CFR 47 § 15.225(e)	A.4	P(Set. NFC02)
5	20dB Bandwidth	CFR 47 § 15.215(c)	A.5	P(Set. NFC02, 03)
6	Conducted Emissions	CFR 47 § 15.207	A.6	P(Set. NFC01)

The measurement is carried out according to ANSI C63.4. See **ANNEX A** for details.

Test Conditions:

For this report, all the test cases listed above were tested under normal Temperature, Voltage, Humidity, and Air Pressure. The specific conditions are as following:

Temperature	T min	-20 °C
	T nom	20 °C
	T max	50 °C
Voltage	V min	3.6 V
	V nom	3.7 V
	V max	4.2 V
Humidity	H nom	44%
Air Pressure	A nom	1010 mbar

6.2. Terms Used in the Summary of Test Results

Terms Used in Condition Column:

T nom	Normal Temperature
T min	Low Temperature
T max	High Temperature
V nom	Normal Voltage
V min	Low Voltage
V max	High voltage
H nom	Norm Humidity

A nom	Norm Air Pressure
-------	-------------------

Terms Used in Verdict Column:

P	Pass, The EUT complies with the essential requirements in the standard.
NP	Not Perform, The test was not performed by TMC
NA	Not Applicable, The test was not applicable
F	Fail, The EUT does not comply with the essential requirements in the standard

Abbreviations:

AC	Alternating Current
AFH	Adaptive Frequency Hopping
BW	Band Width
E.I.R.P.	equivalent isotropical radiated power
ISM	Industrial, Scientific and Medical
RF	Radio Frequency
Tx	Transmitter

6.3. Statements

The test cases listed in Section 6.1 of this report for the EUT specified in Section 3 were performed by TMC according to the reference documents in Section 4.

The EUT meets all applicable requirements of the regulations and standards in Section 4.2.

This report only deals with the NFC function among the features described in section 3.

7. Test Equipments Utilized

NO.	NAME	TYPE	SERIES NUMBER	PRODUCER	CAL. DUE DATE (YY-MM-DD)
1.	NFC Tester	E1141	000019	AT4 Wireless	/
2.	RFID Tester	NI PXIe-1062Q	16929DF	VI	2013-12-06
3.	H-field Antenna	HFH2-Z2	829324/0007	R&S	2013-07-02
4.	Spectrum Analyzer	RSA3408A	B 010277	Tektronix	2013-06-05
5.	Thermal Chamber	PL-2G	343074	ESPEC	2013-05-12
6.	Test Receiver	ESU26	100376	R&S	2013-11-07
7.	Spectrum Analyzer	E4440A	MY48250642	Agilent	2014-03-04
8.	EMI Antenna	VULB 9163	514	Schwarzbeck	2014-11-10
9.	EMI Antenna	VULB 9163	482	Schwarzbeck	2014-02-17
10.	EMI Antenna	3117	00119024	ETS-Lindgren	2014-02-02
11.	LISN	ESH2-Z5	829991/012	R&S	2013-04-16
12.	Signal Generator	SMF100A	101295	R&S	2013-11-08
13.	Universal Radio Communication Tester	CMU200	102228	R&S	2013-07-07
14.	Universal Radio Communication Tester	CMU200	114724	R&S	2013-12-10
15.	Universal Radio Communication Tester	CMU200	116455	R&S	2013-05-20
16.	Universal Radio Communication Tester	E5515C	MY48363198	Agilent	2013-07-09
17.	Universal Radio Communication Tester	E5515C	MY48361083	Agilent	2013-03-16

ANNEX A: MEASUREMENT RESULTS

A.1. Electric Field Strength of Fundamental and Outside the Allocated bands

A.1.1. Reference

See Clause 13.5, Clause 13.4, Clause 8, and Annex E of ANSI C63.4-2009 specifically.
See Clause 4, Clause 5, and Clause 6 of ANSI C63.4-2009 generally.

A.1.2. Measurement Methods

The transmitter carrier output levels (E-Field) from the EUT are measured in a semi-anechoic chamber. The EUT is placed on a non-conductive stand of 80cm high, and at a measurement distance of 3m from the receiving antenna. The center of the receiving loop antenna is 1.0 meter above the ground. The E-field is measured with a shielded loop antenna connected to a measurement receiver. Detected E-field was maximized by rotating the EUT through 360° and adjusting the receiving antenna polarizations. The maximization processes were repeated with the EUT positioned respectively in its three orthogonal axes. The measurements were performed with the peak detector and if required, the quasi-peak detector.

The measurement bandwidth is:

Frequency of Emission (MHz)	RBW/VBW
12.56-14.56	10/30 kHz

The E-field measured at 3m is calculated as:

$$\text{E-field (dB}\mu\text{V/m)} = \text{Rx (dB}\mu\text{V)} + \text{Cable Loss (dB)} + \text{AF@3m (dB/m)}$$

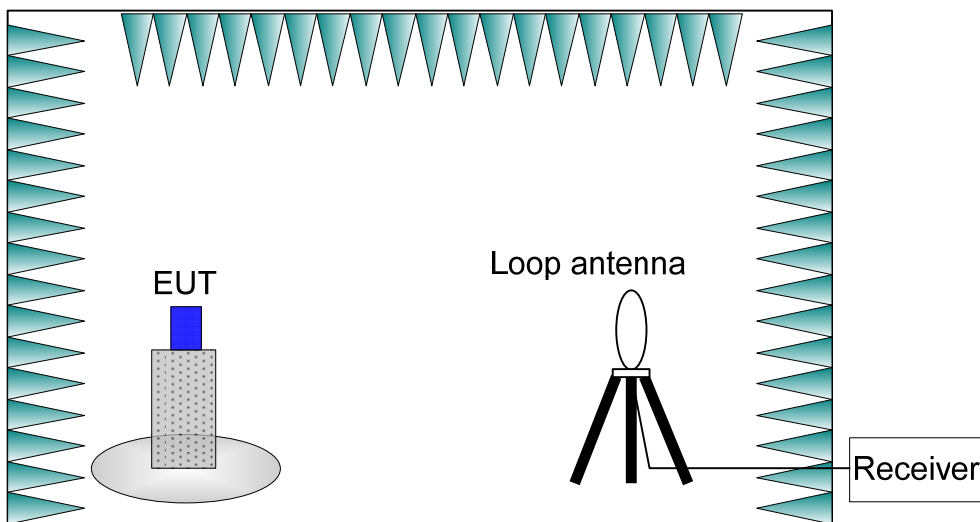

A.1.3. EUT Operating Mode and Test Conditions

The measurement of EUT is carried out under the transmit state of NFC (See 3.5).

The EUT is powered by a travel adapter.

During the measurements, the ambient temperature of the electromagnetic anechoic chamber is in the range of 15 ~ 25 °C.

A.1.4. Limits

Frequency Range (MHz)	E-field Strength Limit @ 30 m (μV/m)	E-field Strength Limit @ 3 m (dBμV/m)
13.560 ± 0.007	+15,848	124
13.410 to 13.553 13.567 to 13.710	+334	90
13.110 to 13.410 13.710 to 14.010	+106	81

Note: Where the limits have been defined at one distance, and a signal level measured at another, the limits have been extrapolated using the following formula:

$$\text{Extrapolation(dB)} = 40\log_{10}(\text{Measurement Distance}/\text{Specification Distance})$$

A.1.5. Measurement Results

Measurement results of normal conditions see Figure A-1 for different set-ups of EUT. The result displayed take into account applicable antenna factors and cable losses.

Conclusions: Set. NFC03, **PASS**.

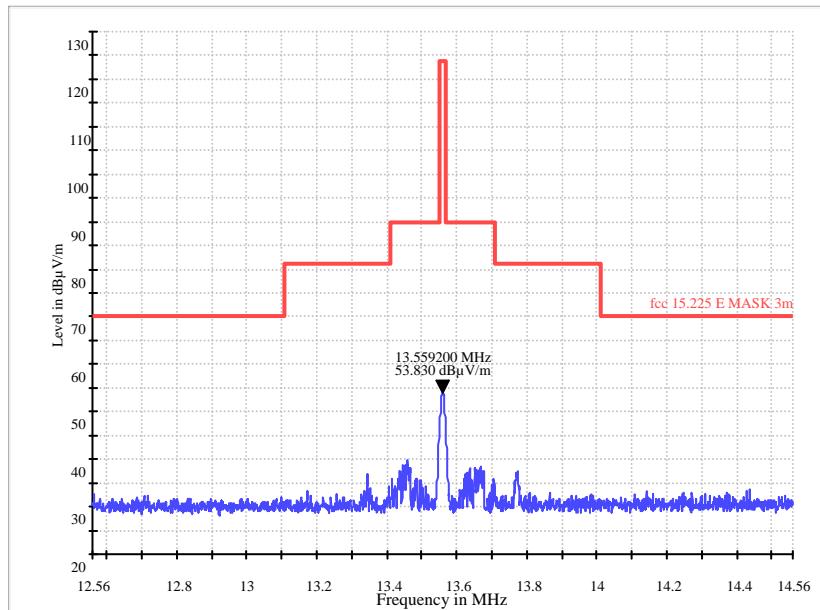

Figure A-1: Set. NFC03

A.1.6. Measurement Uncertainty

Measurement uncertainty: $U = 4.0$ dB, $k=2$.

A.2. Electric Field Radiated Emissions (< 30MHz)

A.2.1. Reference

See Clause 13.4, Clause 8 and Annex E of ANSI C63.4-2009 specifically.

See Clause 4, Clause 5, and Clause 6 of ANSI C63.4-2009 generally.

A.2.2. Measurement Methods

The transmitter carrier output levels (E-Field) from the EUT are measured in a semi-anechoic chamber. The EUT is placed on a non-conductive stand of 80cm high, and at a measurement distance of 3m from the receiving antenna. The center of the receiving loop antenna is 1.0 meter above the ground. The E-field is measured with a shielded loop antenna connected to a measurement receiver. Detected E-field was maximized by rotating the EUT through 360° and adjusting the receiving antenna polarizations. The maximization processes were repeated with the EUT positioned respectively in its three orthogonal axes. The measurements were performed with the peak detector and if required, the quasi-peak detector.

The measurement bandwidth is:

Frequency of Emission (MHz)	RBW/VBW
0.009-0.15	100/300 Hz
0.15-30	10/30 kHz

The E-field measured at 3m is calculated as:

$$\text{E-field (dB}\mu\text{V/m)} = \text{Rx (dB}\mu\text{V)} + \text{Cable Loss (dB)} + \text{AF@3m (dB/m)}$$

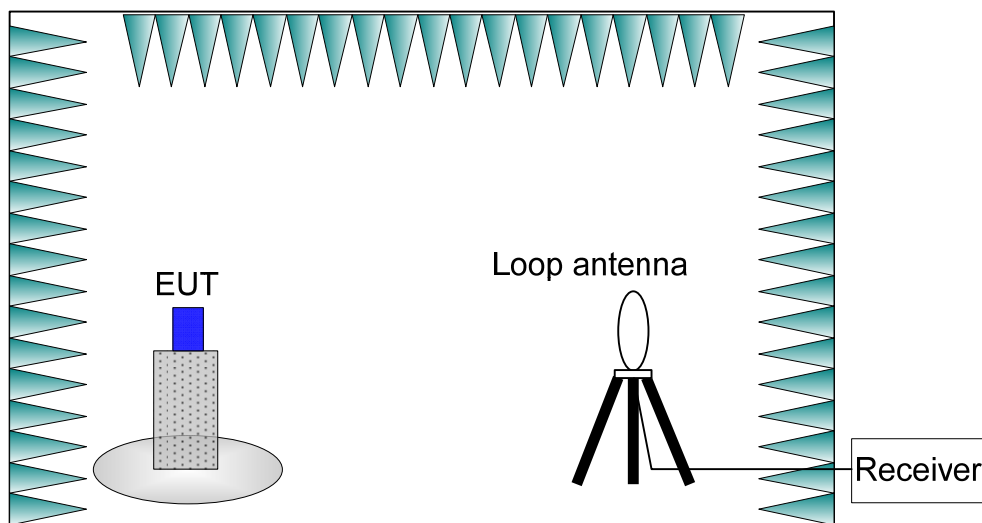

A.2.3. EUT Operating Mode and Test Conditions

The measurement of EUT is carried out under the transmit state of NFC (See 3.5).

The EUT is powered by a travel adapter.

During the measurements, the ambient temperature of the electromagnetic anechoic chamber is in the range of 15 ~ 25 °C.

A.2.4. Limits

Frequency Range (MHz)	E-field Strength Limit @ 30m (mV/m)	E-field Strength Limit @ 3m (dBµV/m)
0.009-0.490	2400/F(kHz)	129-94
0.490-1.705	24000/F(kHz)	74-63
1.705-30	30	70

Note: Where the limits have been defined at one distance, and a signal level measured at another, the limits have been extrapolated using the following formula:

$$\text{Extrapolation(dB)} = 40\log_{10}(\text{Measurement Distance}/\text{Specification Distance})$$

A.2.5. Measurement Results

Measurement results of normal conditions see Figure A-2 for different set-ups of EUT. The result displayed take into account applicable antenna factors and cable losses.

Conclusions: Set. NFC01, **PASS**.

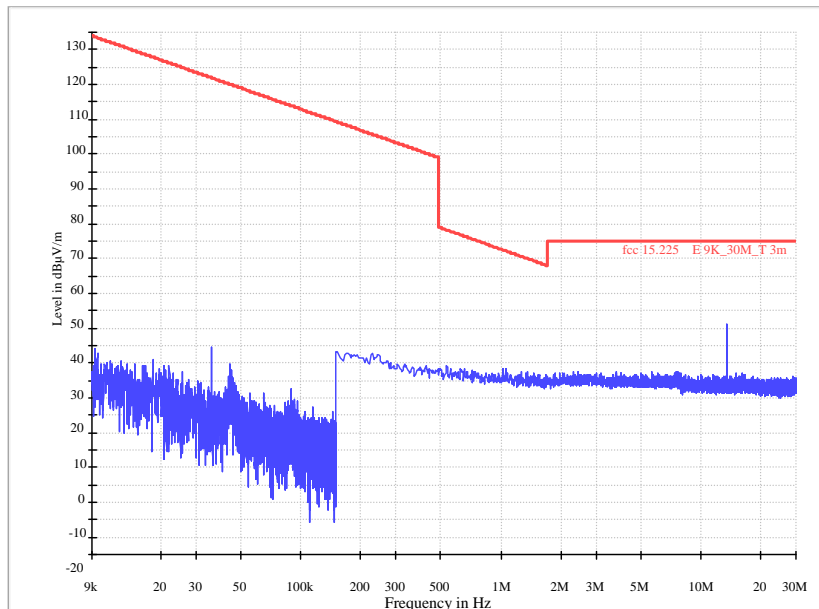

Figure A-2: Set. NFC01

A.2.6. Measurement Uncertainty

Measurement uncertainty: $U = 4.0$ dB, $k=2$.

A.3. Electric Field Radiated Emissions (≥30MHz)

A.3.1. Reference

See Clause 13.4, Clause 8, and Annex E of ANSI C63.4-2009 specifically.

See Clause 4, Clause 5, and Clause 6 of ANSI C63.4-2009 generally.

A.3.2. Measurement Methods

The electric field radiated emissions from the EUT are measured in a semi-anechoic chamber. The EUT is placed on a non-conductive stand of 80cm high, and at a measurement distance of 3m from the receiving antenna. The receiving antennas connected to a measurement receiver comply with Clause 15 of ANSI C63.2-1996 and Clause 4.1.5 of ANSI C63.4-2009. In order to search for maximum field strength emitted from the EUT, the receiving antenna can be moved between the height of 1.0 m to 4.0 m. Detected E-field was maximized at each frequency by rotating the EUT through 360° and adjusting the receiving antenna positions for both vertical and horizontal antenna polarizations. The maximization processes were repeated with the EUT positioned respectively in its three orthogonal axes. The measurements were performed with the peak detector and if required, the quasi-peak detector.

The measurement bandwidth is:

Frequency of Emission (MHz)	RBW/VBW
30-1000	120kHz

The E-field measured at 3m is calculated as:

$$E\text{-field (dB}\mu\text{V/m)} = Rx \text{ (dB}\mu\text{V)} + \text{Cable Loss (dB)} + AF@3m \text{ (dB/m)}$$

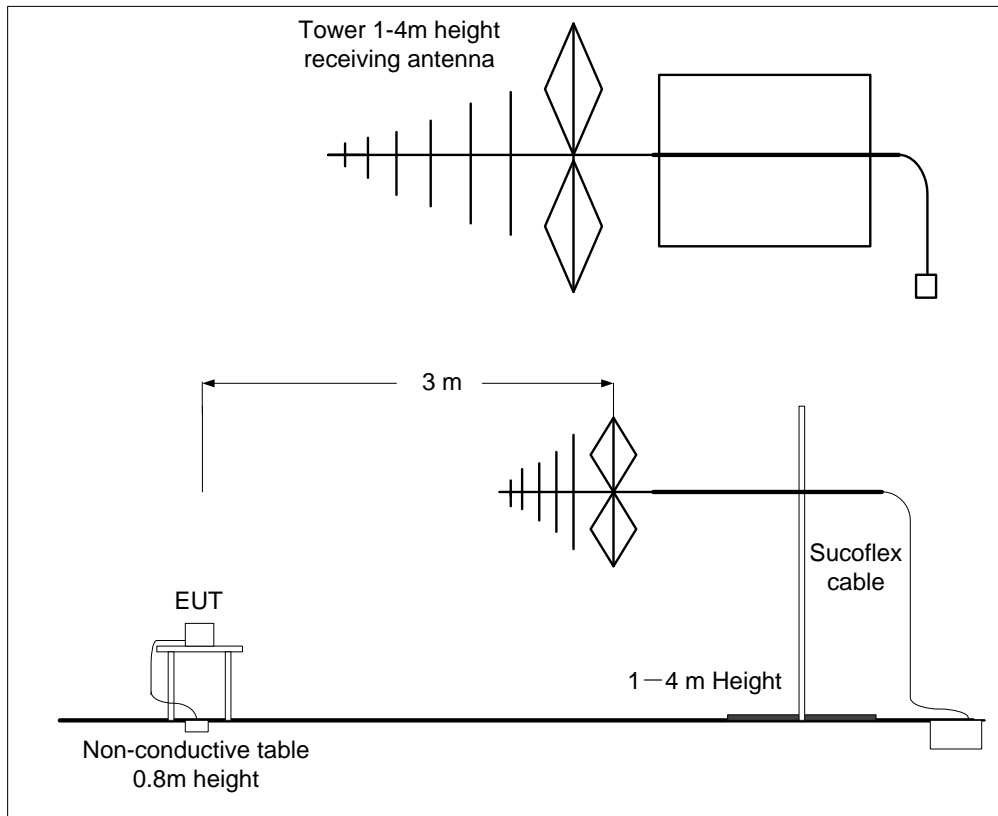

A.3.3. EUT Operating Mode and Test Conditions

The measurement of EUT is carried out under the transmit state of NFC (See 3.5).

EUT1 had been connected to a travel adapter.

During the measurements, the ambient temperature of the electromagnetic anechoic chamber is in the range of 15 ~ 25 °C.

A.3.4. Limits

Frequency Range (MHz)	E-field Strength Limit @ 3m (mV/m)	E-field Strength Limit @ 3m (dB μ V/m)
30-88	100	40
88-216	150	43.5
216-960	200	46

A.3.5. Measurement Results

Measurement results of normal conditions see Figure A-3 for different set-ups of EUT. The result displayed take into account applicable antenna factors and cable losses.

Conclusions: Set. NFC01, **PASS**.

A.3.6. Measurement Uncertainty

Measurement uncertainty: $U = 3.9$ dB, $k=2$

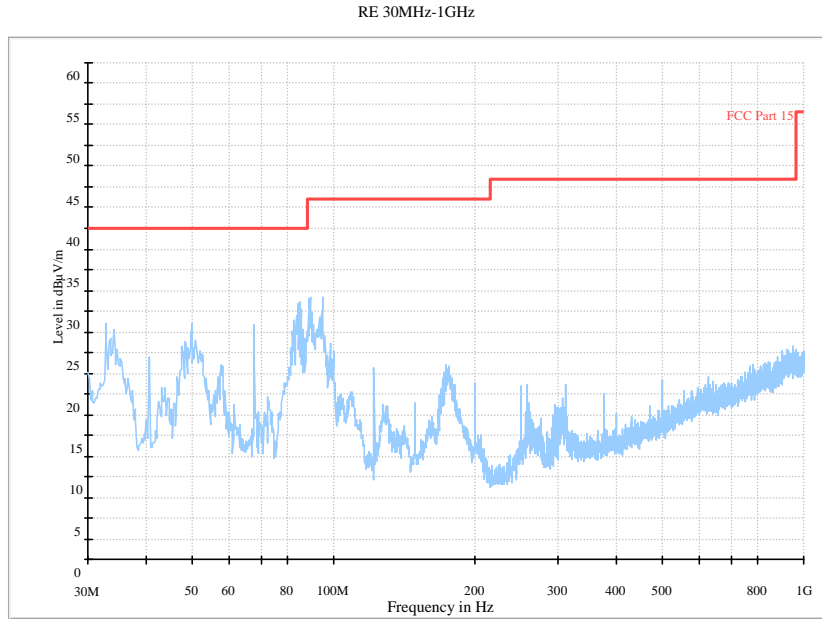

Figure A-3: Set. NFC01

A.4. Frequency Tolerance

A.4.1. Reference

See Clause 13.6 of ANSI C63.4-2009 specifically.

See Clause 4, Clause 5, and Clause 6 of ANSI C63.4-2009 generally.

A.4.2. Measurement Methods

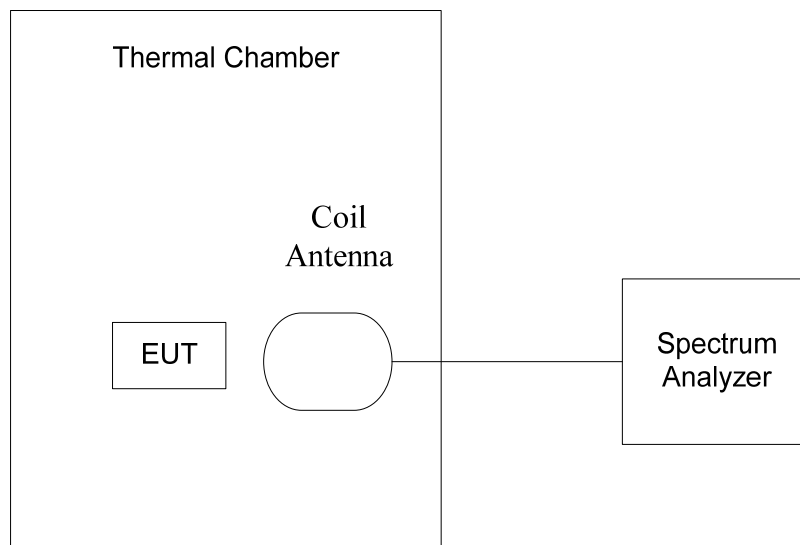

The transmitter output signal was picked up by coil antenna connected to the spectrum analyzer.

The center frequency was measured with 30Hz RBW and 1kHz span.

During the test, the EUT was placed in a thermal chamber until thermal balance and lasting appropriate time.

A.4.3. EUT Operating Mode and Test Conditions

The measurement of EUT is carried out under the transmit state of without modulation (See 3.5).

EUT1 had been not connected to a travel adapter.

Operation Temperature: T min, T nom, and T max with V nom.

Operation Voltage: V min and V max with T nom.

A.4.4. Test Layouts

See A.4.2.

A.4.5. Limits

The frequency tolerance of the carrier signal shall be maintained within +/- 0.01% of the operating frequency.

A.4.6. Measurement Results

Measurement results see Table A-1 for different test conditions.

Conclusions: Set. NFC02, **PASS**.

Table A-1: Frequency Stability VS Temperature and Voltage

Temperature	Voltage	Frequency Error (MHz)			
		Startup	2 Min Later	5 Min Later	10 Min Later
T min	V nom	13.5600849	13.5600561	13.5600401	13.5600080
T max	V nom	13.5600940	13.5600721	13.5600657	13.5600561
T nom	V nom	13.5601202	13.5601152	13.5601139	13.5601102
T nom	V min	13.5601113	13.5601790	13.5601080	13.5601233
T nom	V max	13.5601176	13.5601021	13.5601231	13.5601172

Temperature	Voltage	Frequency Error (%)			
		Startup	2 Min Later	5 Min Later	10 Min Later
T min	V nom	0.001	0.000	0.000	0.000
T max	V nom	0.001	0.001	0.000	0.000
T nom	V nom	0.001	0.001	0.001	0.001
T nom	V min	0.001	0.001	0.001	0.001
T nom	V max	0.001	0.001	0.001	0.001

A.4.7. Measurement Uncertainty

Measurement uncertainty: $U = 77$ Hz, $k=2$

A.5. 20dB Bandwidth

A.5.1. Reference

See Clause 13.7 of ANSI C63.4-2009 specifically.

See Clause 4, Clause 5, and Clause 6 of ANSI C63.4-2009 generally.

A.5.2. Measurement Methods

The transmitter output signal was picked up by coil antenna to the spectrum analyzer.

The transmitter output signal was picked up by coil antenna connected to the spectrum analyzer.

The bandwidth of the center frequency was measured with 100Hz RBW, 300Hz VBW and 5kHz span.

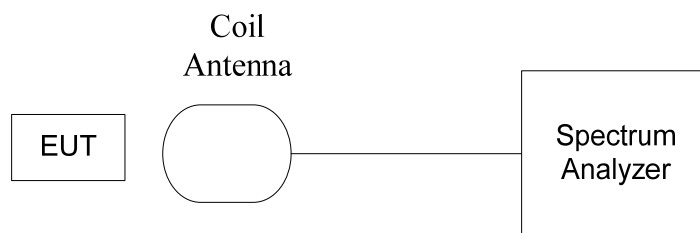

A.5.3. EUT Operating Mode and Test Conditions

The measurement of EUT is carried out under the transmit state of NFC and without modulation (See 3.5).

EUT1 had been not connected to a travel adapter..

During the measurements, the ambient temperature is in the range of 15 ~ 25 °C.

A.5.4. Test Layouts

See A.5.2.

A.5.5. Limits

The 20dB bandwidth shall be less than 80% of the permitted frequency band. For 13.56 MHz NFC, the permitted frequency band is 14kHz, so the limit is 11.2 kHz.

A.5.6. Measurement Results

Measurement results see Figure A-4 and Figure B-5.

Conclusions: Set. NFC02 and NFC03, **PASS**.

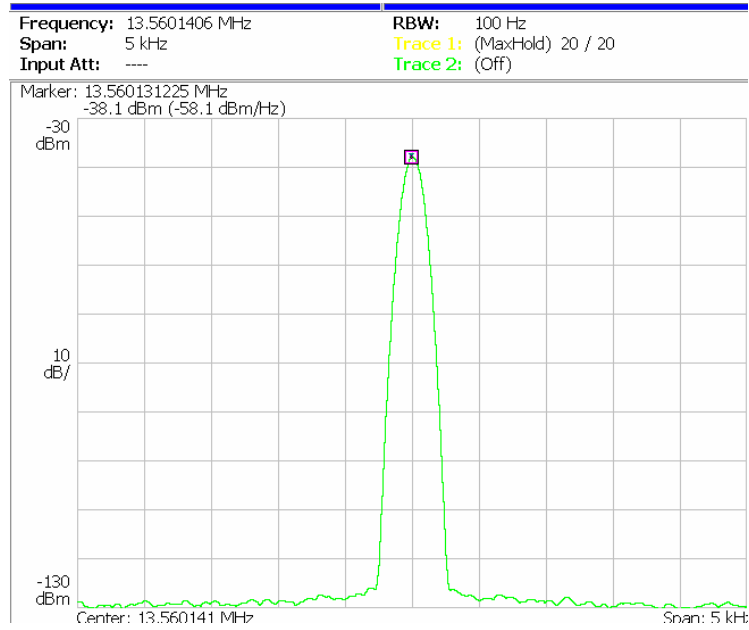

Figure A-4: Test result of EUT1 at test set. NFC02

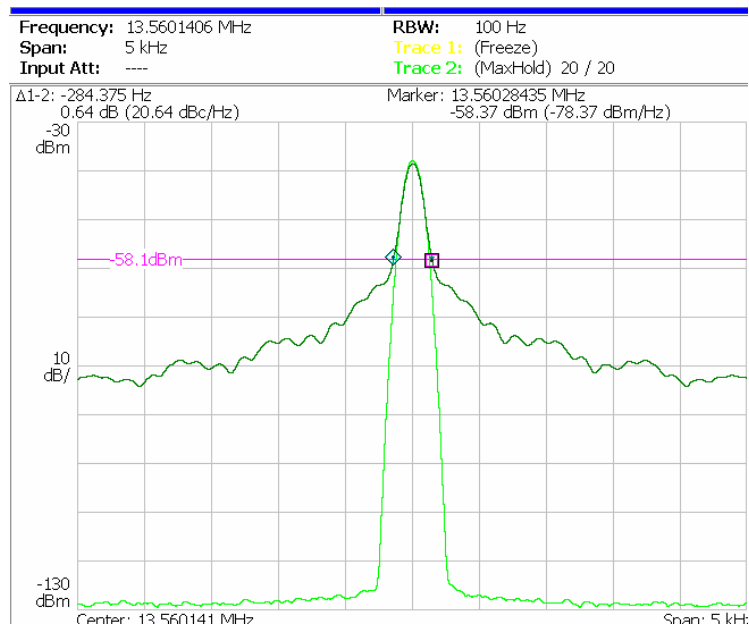

Figure A-5: Test result of EUT1 at test set. NFC03

A.5.7. Measurement Uncertainty

Measurement uncertainty: $U = 77 \text{ Hz}$, $k=2$

A.6 Conducted emission

A.6.1. Reference

See Clause 13.3 and Clause 7 of ANSI C63.4-2009 specifically.
See Clause 4, Clause 5, and Clause 6 of ANSI C63.4-2009 generally.

A.6.2. Measurement Methods

The conducted emissions from the AC port of the EUT are measured in a shielding room. The EUT is connected to a Line Impedance Stabilization Network (LISN). An overview sweep with peak detection was performed. The measurements were performed with a quasi-peak detector and if required, an average detector.

The conducted emission measurements were made with the following detector of the test receiver: Quasi-Peak / Average Detector.

The measurement bandwidth is:

Frequency of Emission (MHz)	RBW/VBW
0.15-30	9kHz

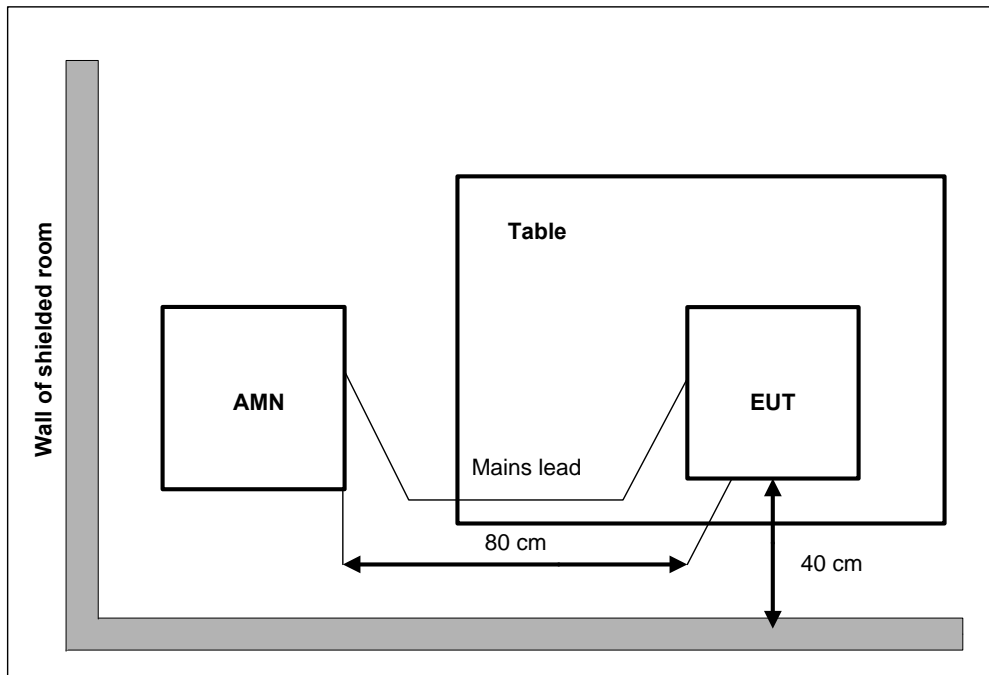

A.6.3. EUT Operating Mode and Test Conditions

The measurement of EUT is carried out under the transmit state of NFC (See 3.5).

The EUT is powered by a travel adapter.

During the measurements, the ambient temperature is in the range of 15 ~ 25 °C.

A.6.4. Limits

Frequency range (MHz)	Quasi-peak Limit (dB μ V)	Average Limit (dB μ V)
0.15 to 0.5	66 to 56	56 to 46
0.5 to 5	56	46
5 to 30	60	50

A.6.5. Measurement Results

Measurement results see Figure A-6.

Conclusions: Set. NFC01, **PASS**.

Note: The measurement result at 13.56MHz is the fundamental emission of NFC signal.

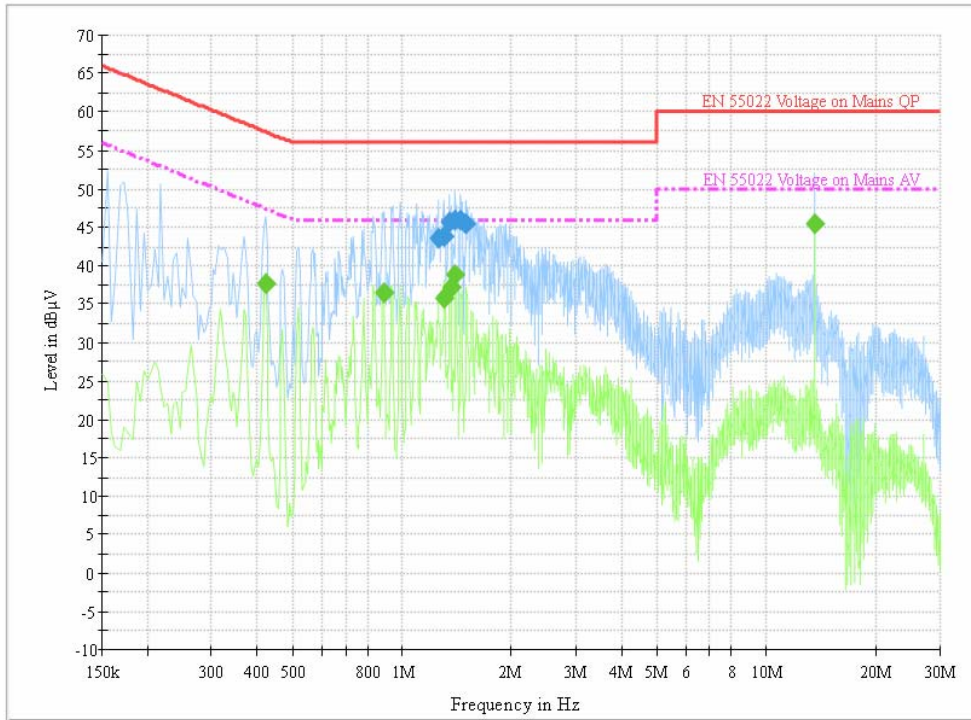

Final Result 1

Frequency (MHz)	QuasiPeak (dBµV)	PE	Line	Corr. (dB)	Margin (dB)	Limit (dBµV)
1.257000	43.5	GND	L1	10.0	12.5	56.0
1.297500	43.7	GND	L1	10.0	12.3	56.0
1.347000	45.7	GND	L1	10.0	10.3	56.0
1.396500	46.0	GND	L1	10.0	10.0	56.0
1.450500	46.0	GND	L1	10.0	10.0	56.0
1.500000	45.4	GND	L1	10.0	10.6	56.0

Final Result 2

Frequency (MHz)	Average (dBµV)	PE	Line	Corr. (dB)	Margin (dB)	Limit (dBµV)
0.420000	37.8	GND	L1	10.0	9.7	47.4
0.888000	36.4	GND	L1	10.0	9.6	46.0
1.306500	35.9	GND	L1	10.0	10.1	46.0
1.356000	37.3	GND	L1	10.0	8.7	46.0
1.401000	38.8	GND	L1	10.0	7.2	46.0
13.560000	45.4	GND	L1	9.7	4.6	50.0

Figure A-6: Test result of EUT1 at test set. NFC01

A.6.6. Measurement Uncertainty

Measurement uncertainty: $U = 3.2$ dB, $k=2$

END OF REPORT