

4 TOP LABEL,  
SVF 930 2395

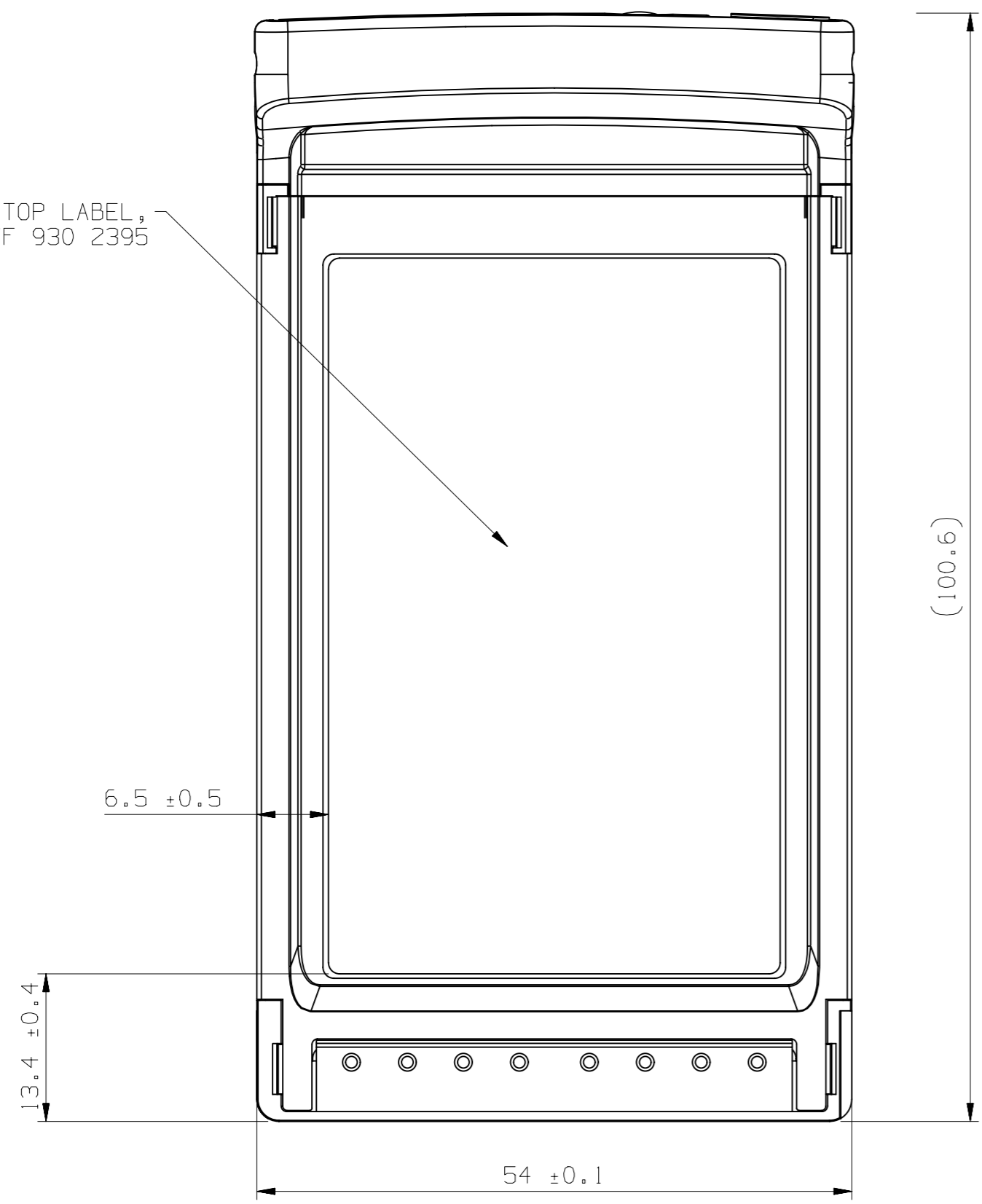

TOP VIEW

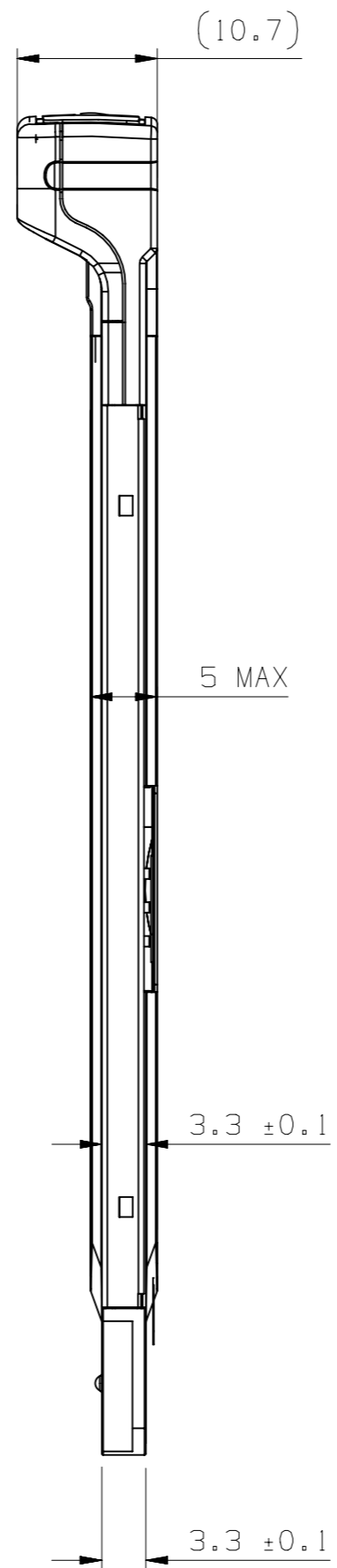

SIDE VIEW

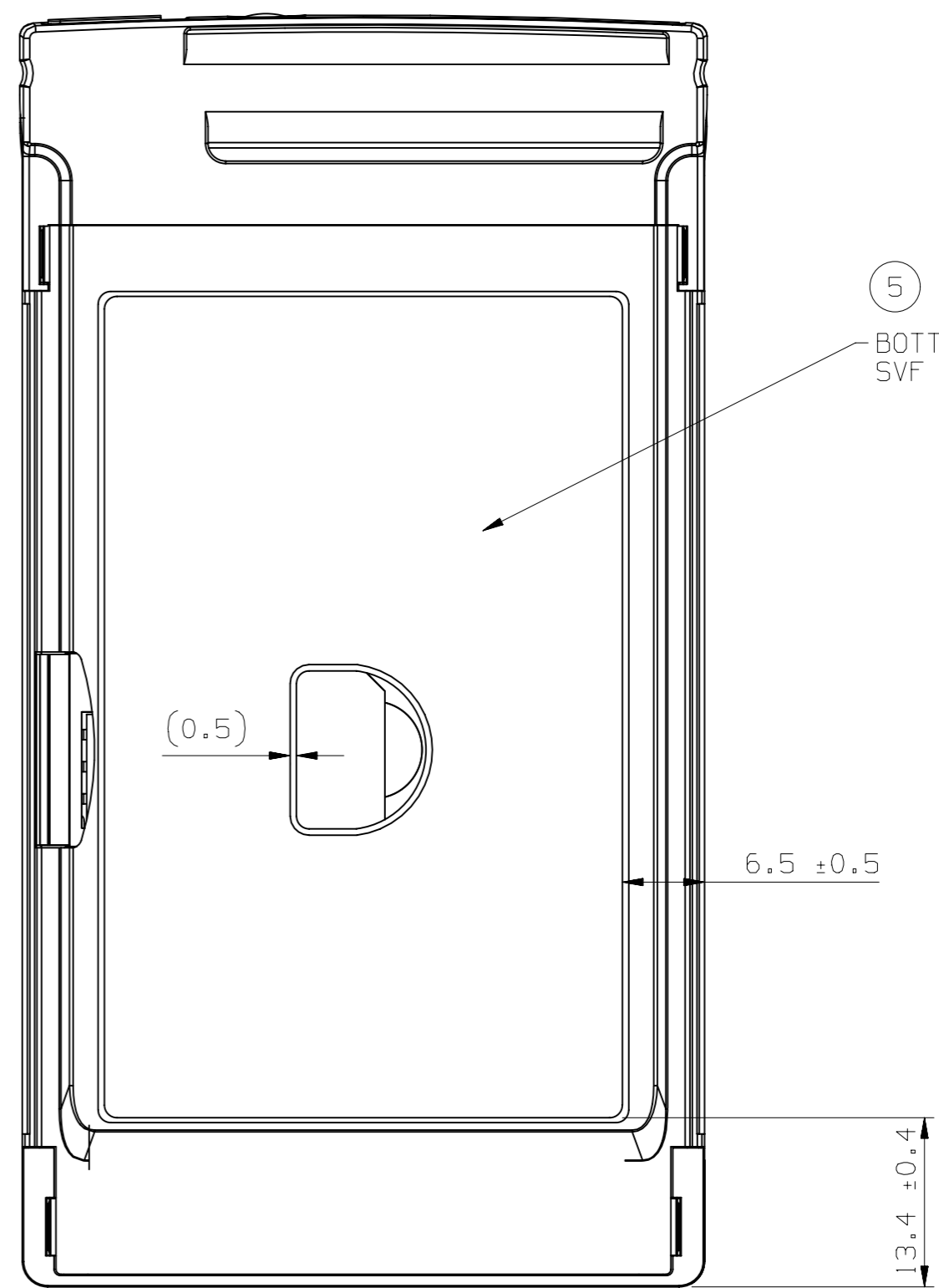

BOTTOM VIEW

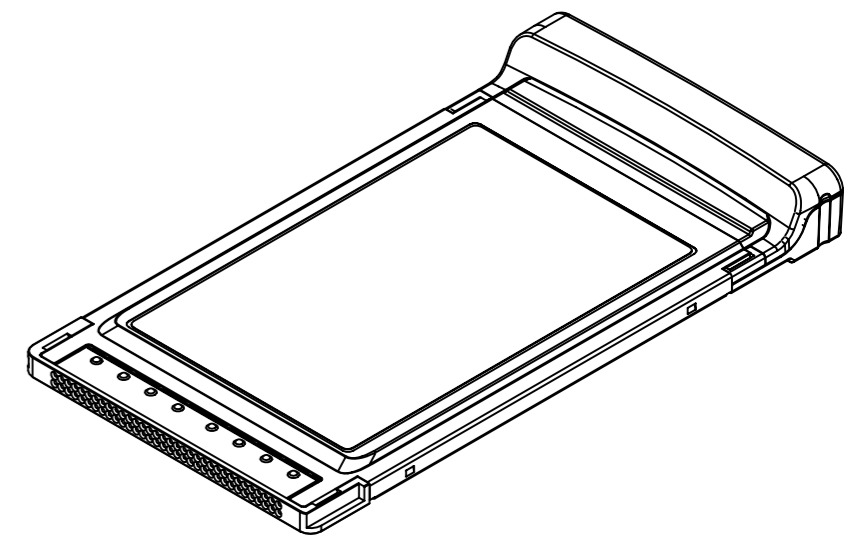

5 BOTTOM LABEL,  
SVF 930 2396

reference document 13132-KRD 104 1024 for position/placement ID numbers.

<b>Sony Ericsson</b>		Prepared (Also Subject Responsible in Other)	
Drawing Rules ASME Y14.5M-1994		/SEM/BMD/H/M B.Meilage	
Tolerance		Doc Responsible/Approved	Date
		/SEM/BMD/H/M (B.Meilage)	2005-04-01 B
Reference 13042-krd1041024_a		Product Name	
Scale 1:1 Units mm Size A2		GC89 PC-CARD MODEM	
Document No.			Sheet
15188-KRD 104 1024 Uen			1 (1)

CONFIDENTIAL

Copyright (c) Sony Ericsson All Rights Reserved

SONY ERICSSON

CE06820

FCC ID: PY7FH-051011



IMEI: 35613200 - 000495 - 3



SN:BL3000495



UPC:095673 17956 6



DSW 14

KRD 104 1024 R1A  
IC: 41708 - FF051011  
DPY1011455/34 R1A  
TYPE FAF - 1051011 - BV  
Made in Mexico GC89

Company Internal  
 SPECIFICATION

Prepared (also subject responsible if other)

GBFA/SEM/BMD/TP Pete Saunders

Approved

GBFA/SEM/BMD/TP (Pam Wood)

Checked

No.

151 86-KRD 104 1024 Uen

Date

2005-02-21

Rev

C

Reference

Approved according to 1776-KRD 104 1024-1

## Marking Drawing GC89 Type FAF-1051011-BV

### Label

The label used for marking is defined in the Manufacturing Specification on the media used.

### Placing

The label shall be placed on the back of the PC card according to the Assembly Drawing (151 88) for the KRD.

### Print layout

Printing area 38 x 26 mm.

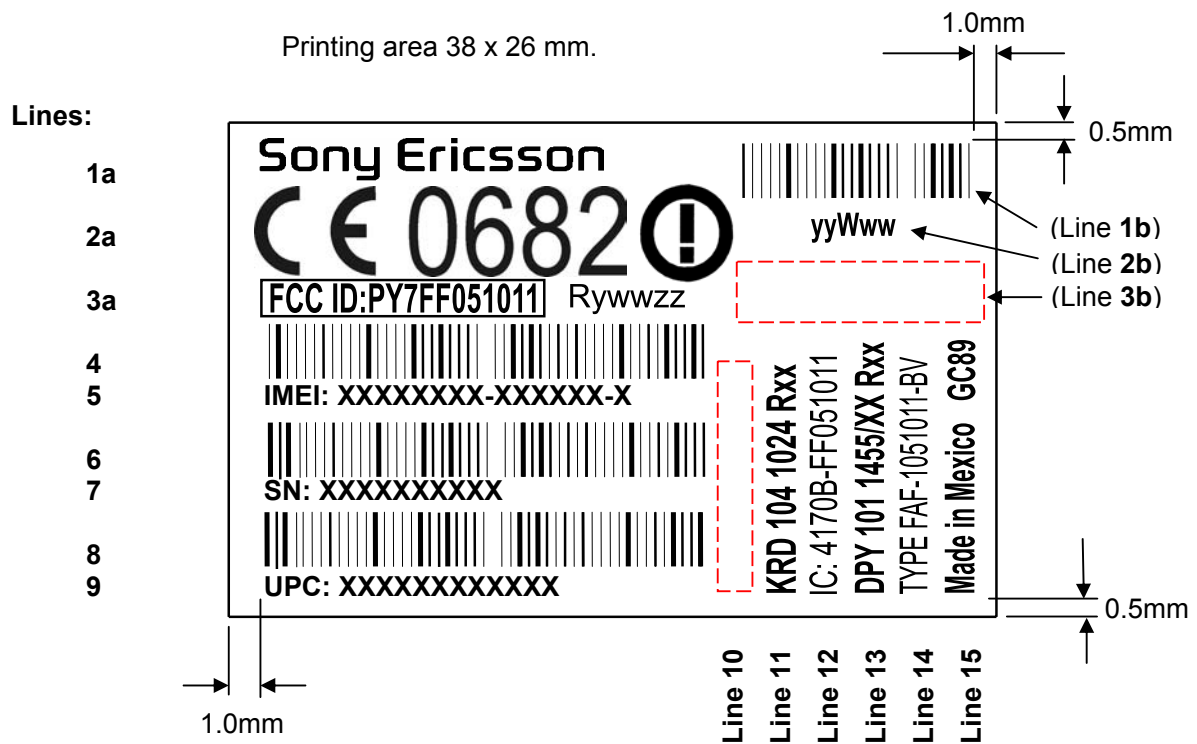

Prepared (also subject responsible if other)

GBFA/SEM/BMD/TP Pete Saunders

Approved

GBFA/SEM/BMD/TP (Pam Wood)

Company Internal  
SPECIFICATION

No.

151 86-KRD 104 1024 Uen

Date

Rev

Reference

2005-02-21

C

Checked

**Definitions**

Line	1a	Sony Ericsson trademark
	1b	Production Week as bar code
	2a	Approval marks (1,2 and 3)
	2b	Production Week as characters
	3a	FCC approval marking and Repair year/week/revision re-work code
	3b	Left blank – space for country approval mark
	4	IMEI number as bar code
	5	IMEI number as characters
	6	Serial number as bar-code
	7	Serial number as characters
	8	UPC number as bar code
	9	UPC number as characters
	10	Left blank – space for country approval mark
	11	KRD number, R-state
	12	Industry Canada marking
	13	Product (DPY) number, R-state
	14	Type number
	15a	Marking of origin
	15b	Product Name “GC89”

Prepared (also subject responsible if other)

GBFA/SEM/BMD/TP Pete Saunders

Approved

GBFA/SEM/BMD/TP (Pam Wood)

Checked

Company Internal  
SPECIFICATION

No.

151 86-KRD 104 1024 Uen

Date

Rev

Reference

2005-02-21

C

Sony Ericsson trademark	Sony Ericsson and the Sony Ericsson trademark shall be according to the corporate standard 190 89-EN/LZT 108 5347. Height min. 3 mm.
Production Week as bar code	According to Ericsson corporate standard 102 01 - 109. Height 3.5 mm
Production week	The production week shall be given as yyWww (yy = year, ww = week)
Approval marks	<ol style="list-style-type: none"> <li>1. CE Marking. According to 1424 - SVF 930 52.</li> <li>2. The Notified Body number. It shall be 0682. The print size (height) for the notified body number and the corresponding approval marks shall be minimum 5 mm. This is a regulatory requirement.</li> <li>3. Alert sign (at same height as CE mark)</li> </ol>
FCC approval marking	<p>FCC approval marking: consists of the text:</p> <p style="text-align: center;">FCC ID: PY7FF051011</p> <p style="text-align: center;"><b><i>Within a frame</i></b> with height &gt; 1.5 mm.</p>
Repair year/week/revision re-work code	<p><b>For service use only.</b></p> <p>The field format shall be Rywwzz, repair year/week/revision.</p> <p><b><u>When the unit leaves manufacturing this field shall be left blank</u></b> with space for the 6-digit repair code to be added during re-work at service center.</p>

Prepared (also subject responsible if other)

GBFA/SEM/BMD/TP Pete Saunders

Approved

GBFA/SEM/BMD/TP (Pam Wood)

Checked

Company Internal  
SPECIFICATION

No.

151 86-KRD 104 1024 Uen

Date

Rev

Reference

2005-02-21

C

Country approval mark 1      Left blank – space for country approval mark

(The Australian A-tick symbol and text will be placed here once approvals are gained)

IMEI number as bar code      See below for definition of IMEI-number. The bar code shall only contain the digits of the IMEI number (no -). Height 3.5 mm.  
IMEI number as characters      The IMEI number has format:  
TAC SNR - CD  
TAC = First eight digits of the Type Approval code after assignment from the Notified Body:

SNR = A serial number from 000 000 to 999 999.

CD = A check digit, from 0-9, calculated according to the Luhn formula (ISO/IEC 7812), GSM 02.16.

Serial number as bar code      According to Ericsson corporate standard 102 01 - 109. Height 3.5 mm.

Serial number as characters      According to Ericsson group standard 0012-101.  
Ericsson group factory number system according the Ericsson corporate standard 1120-101 Factory codes:

Celestica (Monterrey, Mexico) = BL3

UPC number as bar code      According to Ericsson group standard 0012-101. Code 128 Type B. Height 3.5mm.

UPC number as characters      According to AT&T PM-100-1-03.

Country approval mark 2      Left blank – space for country approval mark (Brazilian Anatel approval mark and text will be placed here once approvals are gained)

Prepared (also subject responsible if other)

GBFA/SEM/BMD/TP Pete Saunders

Approved

GBFA/SEM/BMD/TP (Pam Wood)

Checked

Company Internal  
SPECIFICATION

No.

151 86-KRD 104 1024 Uen

Date

Rev

Reference

2005-02-21

C

KRD number	The KRD number for the product.
R-state	The R-state for the KRD according to the 1095 for the KRD.
Industry Canada marking	Industry Canada approval marking: consists of text:  IC: 4170B-FF051011
Product (DPY) number	The DPY number for the product.
R-state	The R-state for the KRD according to the 1095 for the KRD.
Type number	The type number is FAF-1051011-BV and shall be printed "TYPE FAF-1051011-BV".
Marking of origin	Marking of origin and shall be printed "Made in Mexico".



Prepared (also subject responsible if other)

GBFA/SEM/BMD/TP Pete Saunders

Approved

GBFA/SEM/BMD/TP (Pam Wood)

Checked

Company Internal  
SPECIFICATION

No.

151 86-KRD 104 1024 Uen

Date

Rev

Reference

2005-02-21

C

**Printing regulations**

Fontface:	OCR-B
Type size:	min. 1.3 mm
Line spacing:	min. 0.3 mm
Trade mark height:	min. 3 mm
Approval marks height:	min. 5 mm
Colour:	Black
Margins:	1.0mm clear margin on Left & Right edges 0.5mm clear margin on Top & Bottom edges
Layout:	Lines 10 to 15 should be Justified to the Bottom & Right label margins.



Company Internal  
SPECIFICATION

Prepared (also subject responsible if other)

GBFA/SEM/BMD/TP Pete Saunders

Approved

GBFA/SEM/BMD/TP (Pam Wood)

Checked

No.

151 86-KRD 104 1024 Uen

Date

2005-02-21

Rev

C

Reference

Completed label;

NOTE – label shown as per factory configuration = repair re-work code not shown.

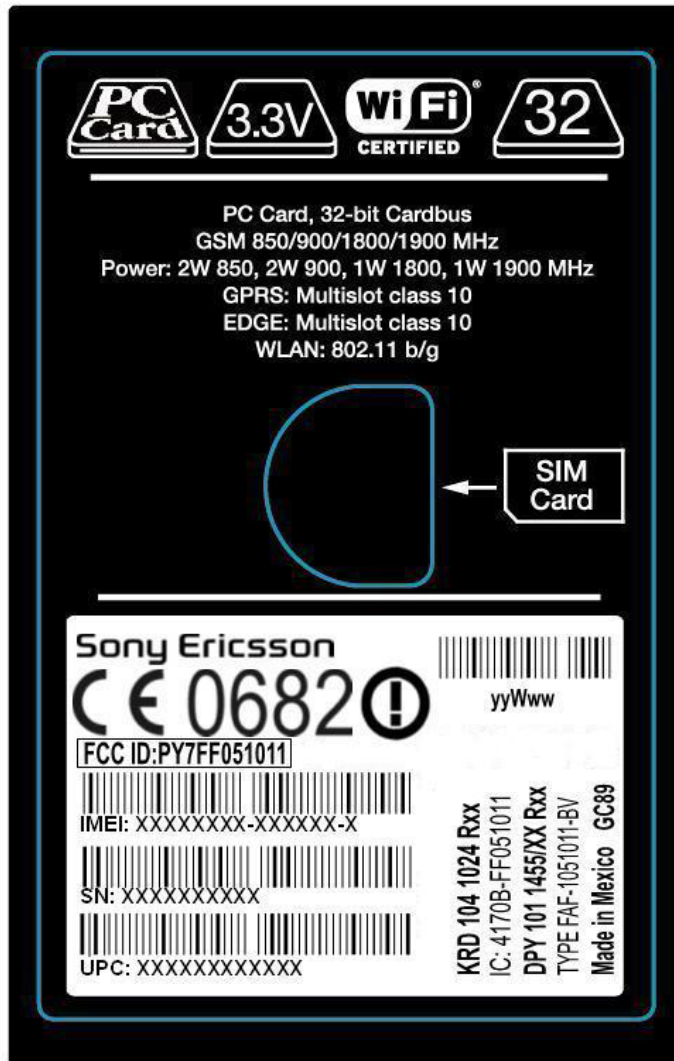

Prepared (also subject responsible if other)

GBFA/SEM/BMD/TP Pete Saunders

Approved

GBFA/SEM/BMD/TP (Pam Wood)

Checked

 Company Internal  
 SPECIFICATION

No.

151 86-KRD 104 1024 Uen

Date

2005-02-21

Rev

C

Reference

### Print layout for prototypes

Line 2 is replaced with text with alternative shown below. Type size min. 5 mm.

DEMO  
 PROTOTYPE 2A  
 PROTOTYPE 2B  
 PROTOTYPE 2C  
 etc.

Line 3 is left blank.

Lines 4 and 5 the field shall be filled with the **test** IMEI number.

The test IMEI number is: **XXXXXXXX**- and the SNR are between **XXXXXX** to **XXXXXX** (the CD number must be added)



Lines 6 and 7 the field shall be filled with the serial number.

Lines 8 and 9 are replaced with text "NOT TYPE APPROVED". Text height min. 2 mm. Under this text the following fields should be put:

- Production week, Product number, R-state. Text height min. 1.3 mm.
- Text "Made by Sony Ericsson". Text height min. 1.3 mm.

**LINES**

 1  
 2  
 3  
 4  
 5  
 6  
 7  
 8  
 9

<b>Sony Ericsson</b>	
<b>XXXXXXXXXX</b>	
	
<b>XXXXXX-XX-XXXXXX-X</b>	
	
<b>XXXXXXXXXX</b>	
<b>NOT TYPE APPROVED</b>	
<b>yyWww</b>	<b>KRD 104 1024 RXX</b>
<b>Made by Sony Ericsson</b>	

Prepared (also subject responsible if other)

GBFA/SEM/BMD/TP Pete Saunders

Approved

GBFA/SEM/BMD/TP (Pam Wood)

Checked

Company Internal  
SPECIFICATION

No.

151 86-KRD 104 1024 Uen

Date

2005-02-21

Rev

C

Reference

Completed label;

NOTE – “CERTIFIED” text over-printed with a black line to ensure it is NOT legible.

