

**Report issued by an Accredited Laboratory**
Rapport utförd av ett ackrediterat laboratorium

This laboratory is accredited to SS-EN ISO/IEC 17025
(SWEDAC accreditation no. 1761).

SAR Test Report, FCC ID: PY7F1022013



Document number:	EAB-07:022495 Uen Rev B	Date of report:	2007-05-07
Testing laboratory:	Ericsson EMF Research Laboratory Ericsson AB SE-164 80 Stockholm Sweden	Company/Client:	Lars Melin Sony Ericsson Mobile Communications AB Box 64 SE-164 94 Stockholm Sweden
Tests performed by:	Björn Hansson	Date of tests:	April 04-05 2007
Manufacturer and market name(s) of device:	Sony Ericsson Mobile Communications AB, P1c		
Testing has been performed in accordance with:	IEEE Std 1528, IEC 62209-1, FCC OET Bulletin 65 Supplement C		
Test results:	The tested device complies with the requirements in respect of all parameters subject to the test.		
Additional information:			
Signature:			
	Test engineer	Quality manager	
			
	Björn Hansson Research Engineer bjorn.hansson@ericsson.com Tel: +46 8 404 22 02	Christer Törnevik Director, EMF Health and Safety christer.tornevik@ericsson.com Tel: +46 8 7641235	

Table of Contents

Table of Contents	2
1 Summary of SAR Test Report	3
1.1 Equipment under test (EUT)	3
1.2 Results	3
2 General information	4
3 Equipment under test	4
4 Test equipment	5
4.1 Dosimetric system	5
4.2 Additional equipment	5
5 Electrical parameters of the tissue simulating liquids	6
6 SAR system performance check	7
7 Uncertainty evaluation of SAR measurement system DASY4 according to IEEE 1528	8
8 Test results	9
8.1 Results for the GSM1900 mode (head)	10
8.2 Results for the GSM1900 mode (body)	10
8.3 Results for the GPRS(2Tx)1900 mode (body)	11
8.4 Results for the GPRS(1Tx)1900 mode (body)	11
8.5 Multi-mode maximum SAR	11
Conclusion	12
9 References	12
10 Revision History	12
APPENDIX A: Photographs of the EUT	13
APPENDIX B: Photographs of the EUT when positioned for SAR measurements	14
APPENDIX C: SAR distribution plots for the system performance checks	16
APPENDIX D: SAR distribution plots	19
APPENDIX E: Probe calibration parameters for ES3DV3, S/N: 3113	25

1 Summary of SAR Test Report¹

1.1 Equipment under test (EUT)

Serial Number	CB5A0A6CGA
Type Number	FAB-1022013-BV
Device ID	FCC ID:PY7F1022013 IC: 4170B-F1022013
Accessories used in testing	Handsfree HPM-62, Bluetooth Handsfree HBH-DS970 Battery BST-40 (with Chinese text)
Hardware status	Pre-production EP4.2
Notes	-

Frequency Band [MHz]	850		900	1800	1900		2100	2450
Modes	GSM GPRS	WCDMA	GSM GPRS	GSM GPRS	GSM GPRS	WCDMA	WCDMA	WLAN
Supported	<input type="checkbox"/>	<input type="checkbox"/>	<input checked="" type="checkbox"/>	<input checked="" type="checkbox"/>	<input checked="" type="checkbox"/>	<input type="checkbox"/>	<input type="checkbox"/>	<input type="checkbox"/>
Covered by report	<input type="checkbox"/>	<input type="checkbox"/>	<input type="checkbox"/>	<input type="checkbox"/>	<input checked="" type="checkbox"/>	<input type="checkbox"/>	<input type="checkbox"/>	<input type="checkbox"/>
Data and connectivity	GPRS class 10, GPRS capability class B, Bluetooth class 2							
Exposure environment	General public							

1.2 Results

The maximum SAR values are given in the table below. The device conforms to the requirements of the relevant standards when the maximum SAR value is less than or equal to the limit.

Results applicable to the 1g SAR limit of 1.6 W/kg:

	Mode	Channel/Frequency (MHz)	Position	Max SAR _{1g} for single mode operation	Max SAR _{1g} for multi-mode operation ²	SAR _{1g} limit ³	Result
HEAD	GSM 1900	661 / 1880.0	Left, Cheek	1.02 W/kg	1.02 W/kg	1.6 W/kg	PASSED
BODY	GSM 1900	810 / 1909.8	Back, 15mm	1.14 W/kg	1.09 W/kg	1.6 W/kg	PASSED
BODY	GPRS 1900	810 / 1909.8	Back, 15mm	1.28 W/kg	1.16 W/kg	1.6 W/kg	PASSED

Extended Uncertainty (k=2) 95%	± 21.9 %
--------------------------------	----------

¹ This page contains a summary of the test results. The full report provides a complete description of all test details and results.

² Cellular and Bluetooth operating simultaneously

³ SAR limit applicable in USA and Canada

2 General information

The tests reported in this document have been performed in accordance with the SAR measurement standards IEC 62209-1 [1], IEEE Standard 1528 [2] and the FCC OET Bulletin 65 Supplement C [3]. The purpose of the tests was to verify that the EUT is in compliance with the appropriate RF exposure standards, recommendations and limits [3-4].

3 Equipment under test

The tables below summarize the technical data for the equipment under test. Photographs of the device are presented in Appendix A.

Device model	Type No: FAB-1022013-BV FCC ID: PY7F1022013 IC: 4170B-F1022013
Serial number of tested unit(s)	CB5A0A6CGA
Mode(s) covered by this report	GSM/GPRS1900
Antenna(s)	Internal
Maximum output power level⁴ (dBm)	GSM/GPRS(1Tx)1900: 30.5 GPRS(2Tx)1900: 27.5 Bluetooth: 4.0
GPRS Class, GPRS capability class	10, B
Duty cycle(s)	1:8 (GSM), 1:4 (GPRS)
Transmitter frequency range (MHz)	GSM1900: 1850.2-1909.8
Hardware status	Pre-production EP4.2
Software(s)	CXC162037 R9F010, CXC162143 R1C, CXC162157 R1A21, CDA162022/5 R1A19
Tested accessories	Stereo Handsfree HPM-62 Bluetooth Handsfree HBH-DS970
Tested batteries	BST-40 (with Chinese text)

GSM/GPRS 1900 MHz Output power					
Mode	Nominal output power (dBm)	Tolerance, upper limit (dB)	EUT power ⁵ (dBm)		
			Ch 512	Ch 661	Ch 810
GSM/GPRS(1Tx) 1900	30.0	+0.5	30.7	30.5	30.5
GPRS(2Tx) 1900	27.0	+0.5	27.6	27.4	27.5

⁴ Output power level of the phone at the antenna port for the maximum power setting. This equals the nominal output power level plus the tolerance in production.

⁵ The EUT was tuned to specified nominal output power plus production tolerance at mid channel, resulting in a higher output power than any production unit at low channel.

4 Test equipment

4.1 Dosimetric system

The SAR measurements were performed using the DASY4 professional near-field scanner by Schmid & Partner Engineering AG that was installed in December 2002. An uncertainty budget including total uncertainty (k=1) and expanded uncertainty (k=2) for 1g and 10g SAR is found in section 7. The equipment list is given below. In Appendix E calibration parameters for the SAR test probe(s) are listed.

Description	Serial number	Calibration due date	Calibration interval
Probe electronics, DAE3	S/N 422	2007-05-17	12 months
E-field probe, ES3DV3	S/N 3113	2007-06-30	12 months
Dipole validation kit, D1900V2	S/N 510	NA	NA
SAM Phantom (SAM1)	S/N TP-1390	NA	NA

4.2 Additional equipment

Description	Serial number	Calibration due date	Calibration interval
Dielectric probe kit, HP 85070C	S/N US99360060	NA	NA
Network analyzer, HP 8752C	S/N 3410A03732	2007-11-03	12 months
Power meter, R&S NRVS	S/N 848888/052	2008-06-06	24 months
Power sensor, R&S NRV-Z5	S/N 849895/030	2008-06-06	24 months
Universal radio communication tester, R&S CMU 200	S/N 107639	2007-04-26	12 months
Thermometer, EBRO TFX-392SKWT	S/N 10130918	2007-07-17	12 months

5 Electrical parameters of the tissue simulating liquids

The parameters of the tissue simulating liquids were measured using the network analyzer and the dielectric probe kit prior to the SAR measurement. The results are shown in the table below. Specified standard values for the permittivity and the conductivity are given in [1-3]. The measured values are within 5% of the standard values. The mass density of the liquid entered into the DASY4 program was 1000 kg/m³. The depth of the tissue simulating liquid was 15±0.5 cm as shown in the figures below.

F (MHz)	Liquid type	Measured/Specification	ϵ_r	σ (S/m)
1900	Head	Measured	38.7	1.39
		Specified value	40.0	1.40
		Difference (%)	-3.3	-0.7
	Body (muscle)	Measured ⁶	51.2 51.3	1.57 1.59
		Specified value	53.3	1.52
		Difference (%) ⁶	-3.9 -3.8	+3.3 +4.6



Measured level (151 mm, head section) of 1900 MHz head tissue simulating liquid in phantom.



Measured level (151 mm, flat section) of 1900 MHz muscle tissue simulating liquid in phantom

⁶ 1900 Body tissue simulating liquid was measured at two occasions. See SAR system performance check table in section 6.

6 SAR system performance check

System performance checks for the DASY4 were conducted before the SAR measurements with the D1900V2 dipole kit and the obtained results are displayed in the table below. The results are within 10% of the reference values [2],[5]. Evaluations prior to the SAR testing showed that the maximum SAR system noise was below 2 mW/kg, which is below the standard requirements. The temperature of the test facility during the system performance checks was in the range 20°C to 25°C.

f (MHz)	Liquid type	Measured/Reference	SAR 1g (W/kg)	SAR 10g (W/kg)	ϵ_r	σ (S/m)	Liquid temp (°C)	Date
1900	Head	Measured	39.7	20.8	38.7	1.39	22.5	070405
		Reference [2]	39.7	20.5	40.0	1.40	-	-
		Difference (%)	±0	+1.5	-3.3	-0.7	-	-
	Body (muscle)	Measured ⁷	41.7 43.0	21.4 22.2	51.2 51.3	1.57 1.59	22.2 22.5	070404 070405
		Reference [5]	40.4	21.1	53.3	1.52	-	-
		Difference (%)	+3.2 +6.4	+1.4 +5.2	-3.9 -3.8	+3.3 +4.6	-	-

⁷ System performance checks and measurements in 1900 MHz muscle tissue simulating liquid were performed at two different occasions.

7 Uncertainty evaluation of SAR measurement system DASY4 according to IEC 62209-1 [1] and IEEE 1528 [2]

Uncertainty Component	Section in IEEE 1528	Uncer. (%)	Prob Dist.	Div.	$C_{i,1g}$	$C_{i,10g}$	Std. Uncer. (1g) (%)	Std. Uncer. (10g) (%)
Measurement System								
Probe Calibration	E2.1	±5.9	N	1	1	1	±5.9	±5.9
Axial Isotropy	E2.2	±4.7	R	√3	0.7	0.7	±1.9	±1.9
Spherical Isotropy	E2.2	±9.6	R	√3	0.7	0.7	±3.9	±3.9
Boundary Effect	E2.3	±1.0	R	√3	1	1	±0.6	±0.6
Linearity	E2.4	±4.7	R	√3	1	1	±2.7	±2.7
System Detection Limits	E2.5	±1.0	R	√3	1	1	±0.6	±0.6
Readout electronics	E2.6	±0.3	N	1	1	1	±0.3	±0.3
Response time	E2.7	±0.8	R	√3	1	1	±0.5	±0.5
Integration time	E2.8	±2.6	R	√3	1	1	±1.5	±1.5
RF Ambient Noise	E6.1	±3.0	R	√3	1	1	±1.7	±1.7
RF Ambient Reflections	E6.1	±3.0	R	√3	1	1	±1.7	±1.7
Probe Positioner	E6.2	±0.4	R	√3	1	1	±0.2	±0.2
Probe Positioning	E6.3	±2.9	R	√3	1	1	±1.7	±1.7
Max. SAR Evaluation	E5	±1.0	R	√3	1	1	±0.6	±0.6
<i>Measurement System Uncertainty</i>							±8.6	±8.6
Test Sample Related								
Device positioning	E4.2	±2.9	N	1	1	1	±2.9	±2.9
Device holder uncertainty	E4.1	±3.6	N	1	1	1	±3.6	±3.6
Power drift	6.6.3	±5.0	R	√3	1	1	±2.9	±2.9
<i>Test Sample Related Uncertainty</i>							±5.5	±5.5
Phantom and Tissue Parameters								
Phantom uncertainty	E3.1	±4.0	R	√3	1	1	±2.3	±2.3
Liquid conductivity (meas uncertainty)	E3.3	±2.5	N	1	0.64	0.43	±1.6	±1.1
Liquid conductivity (target)	E3.2	±5.0	R	√3	0.64	0.43	±1.8	±1.2
Liquid Permittivity (meas uncertainty)	E3.3	±2.5	N	1	0.6	0.49	±1.5	±1.2
Liquid Permittivity (target)	E3.2	±5.0	R	√3	0.6	0.49	±1.7	±1.4
<i>Phantom and Tissue Parameters Uncertainty</i>							±4.9	±3.4
Combined standard uncertainty							±10.9	±10.7
Extended standard uncertainty (k=2)							±21.9	±21.4

Uncertainty budget is applicable for both head and body measurements.

8 Test results

The tables in this section show the measured 1g and 10g averaged SAR for the device and the corresponding values normalized to the maximum output power level. A universal radio communication tester was used to control the device during the SAR measurements on the cellular band. The phone was supplied with a fully charged battery for the tests. The temperature of the test facility during the tests was in the range 20 to 25°C. During the tests, the temperature of the tissue simulating liquid was within $\pm 2^\circ\text{C}$ from the liquid temperature at system performance check.

The device was tested on the right-hand phantom, corresponding to the right side of the head, and the left-hand phantom for the cheek and tilt phone positions in the middle of each transmit band, corresponding to the traffic channel 661 for GSM/GPRS 1900. In Appendix B, pictures of the device positioned on the head phantom are shown. For the phone position giving the highest SAR result, the device was then also tested at the lowest and the highest frequency of the transmit band corresponding to the traffic channels 512 and 810 for GSM/GPRS 1900. Finally, for the position and frequency giving the highest SAR result, tests were performed with the stylus pen removed and for the maximum configuration with the Bluetooth transmitter turned on. A picture showing the location of the stylus pen is found in Appendix A.

The device was also tested in body worn positions with the front and back side of the device facing the phantom on the middle channel. For the phone position giving the highest SAR result, the device was then tested at the lowest and the highest frequency. Finally, for the position and frequency giving the highest SAR result, tests were performed with the stylus pen removed and for the maximum configuration with the Bluetooth transmitter turned on. All tests in body worn positions were performed at 15 mm separation between the device and the flat phantom, with the stereo handsfree attached for speech and data modes (replaced by Bluetooth handsfree when Bluetooth enabled). In Appendix B, pictures of the device when positioned under the flat section of the phantom are shown.

8.1 Results for the GSM1900 mode (head)

Configuration	Phone position		f (MHz)	Measured output power (dBm)	Measured (W/kg)		Normalized to max power, 30.5 dBm (W/kg)	
					SAR _{1g}	SAR _{10g}	SAR _{1g}	SAR _{10g}
	Left	Cheek	1850.2	30.7	0.77	0.45	0.73	0.42
			1880.0	30.5	0.99	0.57	0.99	0.57
			1909.8	30.5	0.92	0.54	0.92	0.54
	Right	Tilt	1880.0	30.5	0.80	0.48	0.80	0.48
			1880.0	30.5	0.51	0.32	0.51	0.32
			1880.0	30.5	0.76	0.45	0.76	0.45
Pen removed	Left	Cheek	1880.0	30.5	1.02	0.59	1.02	0.59
Bluetooth Pen removed	Left	Cheek	1880.0	30.5	1.02	0.59	1.02	0.59

Appendix D, Figures a-d, show SAR distributions for Right Cheek, Right Tilt, Left Cheek and Left Tilt positions, including the configuration giving the maximum 1g SAR for GSM1900 Head measurements.

8.2 Results for the GSM1900 mode (body)

Separation	Configuration	Phone position	f (MHz)	Measured output power (dBm)	Measured (W/kg)		Normalized to max power, 30.5 dBm (W/kg)	
					SAR _{1g}	SAR _{10g}	SAR _{1g}	SAR _{10g}
15mm between device and flat phantom	Stereo handsfree	Front	1880.0	30.5	0.23	0.14	0.23	0.14
			1850.2	30.7	0.73	0.43	0.70	0.41
		Back	1880.0	30.5	0.91	0.52	0.91	0.52
			1909.8	30.5	0.96	0.55	0.96	0.55
	Stereo handsfree Pen removed	Back	1909.8	30.5	1.14	0.65	1.14	0.65
			Bluetooth Pen removed	Back	1909.8	30.5	1.09	0.62

Appendix D, Figure e, shows the SAR distribution for the configuration giving the maximum 1g SAR for GSM1900 Body measurements.

8.3 Results for the GPRS(2Tx)1900 mode (body)

Separation	Configuration	Phone position	f (MHz)	Measured output power (dBm)	Measured (W/kg)		Normalized to max power, 27.5 dBm (W/kg)	
					SAR _{1g}	SAR _{10g}	SAR _{1g}	SAR _{10g}
15mm between device and flat phantom	Stereo handsfree	Front	1880.0	27.4	-	-	-	-
		Back	1850.2	27.6	0.70	0.41	0.68	0.40
			1880.0	27.4	0.90	0.53	0.93	0.54
			1909.8	27.5	1.02	0.59	1.02	0.59
	Stereo handsfree Pen removed	Back	1909.8	27.5	1.28	0.73	1.28	0.73
	Bluetooth Pen removed	Back	1909.8	27.5	1.16	0.67	1.16	0.67

Appendix D, Figure f, shows the SAR distribution for the configuration giving the maximum 1g SAR for GPRS(2Tx)1900 Body measurements.

8.4 Results for the GPRS(1Tx)1900 mode (body)

Separation	Configuration	Phone position	f (MHz)	Measured output power (dBm)	Measured (W/kg)		Normalized to max power, 30.5 dBm (W/kg)	
					SAR _{1g}	SAR _{10g}	SAR _{1g}	SAR _{10g}
15mm between device and flat phantom	Bluetooth Pen removed	Back	1909.8	30.5	1.14	0.65	1.14	0.65

8.5 Multi-mode maximum SAR

The multi-mode maximum SAR values given in the table below are the maximum sum of SAR for modes that can be used simultaneously, i.e. in this case GSM 1900 combined with Bluetooth. Summation of maximum SAR for obtaining multi-mode SAR is according to the procedures in [6].

Usage position	Modes	Multi-mode SAR, normalized to max power (W/kg)	
		SAR _{1g}	SAR _{10g}
Head	GSM1900 & Bluetooth	1.02	0.59
Body	GSM1900 & Bluetooth	1.09	0.62
	GPRS1900 & Bluetooth	1.16	0.67

Conclusion

The results above show that the maximum SAR for the EUT is below the applicable SAR limits. Consequently, the EUT is in compliance with the appropriate RF exposure standards and recommendations.

9 References

- [1] IEC 62209-1, International Standard, "Human exposure to radio frequency fields from hand-held and body-mounted wireless communication devices – Humans models, instrumentation, and procedures – Part 1: Procedure to determine the Specific Absorption Rate (SAR) for hand-held mobile devices used in close proximity of the ear (frequency range of 300 MHz to 3 GHz)", IEC, February, 2005.
- [2] IEEE, Standard 1528, "Recommended Practice for Determining the Peak Spatial-Average Specific Absorption Rate (SAR) in the Human Head from Wireless Communications Devices: Measurement Techniques.", The Institute for Electrical and Electronics Engineers (IEEE) Inc., June 2003
- [3] FCC, "Evaluating Compliance with FCC Guidelines from Human Exposure To Radiofrequency Electromagnetic Fields", Supplement C Edition 01-01 to OET Bulletin 65 Edition 97-01, June 2001.
- [4] ANSI/IEEE Std C95.1-2005 (Revision of IEEE Std C95.1-1991), "Safety levels with respect to human exposure to radio frequency electromagnetic fields, 3 kHz to 300 GHz", The Institute of Electrical and Electronics Engineers Inc., New York, 2006.
- [5] EAB/TF-03:090, "Calculation of reference SAR values for system performance checks with muscle tissue simulating liquid", Ericsson technical report, December 2006.
- [6] IEC 62209-2, Draft, Human Exposure to Radio Frequency Fields from Handheld and Body-Mounted Wireless Communication Devices -Human models, Instrumentation, and Procedures -Part 2: Procedure to determine the specific absorption rate (SAR) for mobile wireless communication devices used in close proximity to the human body (frequency range of 30 MHz to 6 GHz), March 2007.

10 Revision History

Rev.	Date	Description
A	2007-05-03	First revision
B	2007-05-07	"Pen removed" added to first last row in table 8.1. Spelling error corrected.

APPENDIX A: Photographs of the EUT



(a) Front, right, back and left view of the EUT.



(b) Front of phone with stylus pen partly pulled out.



(c) Battery BST-40 (With Chinese text)

APPENDIX B: Photographs of the EUT when positioned for SAR measurements

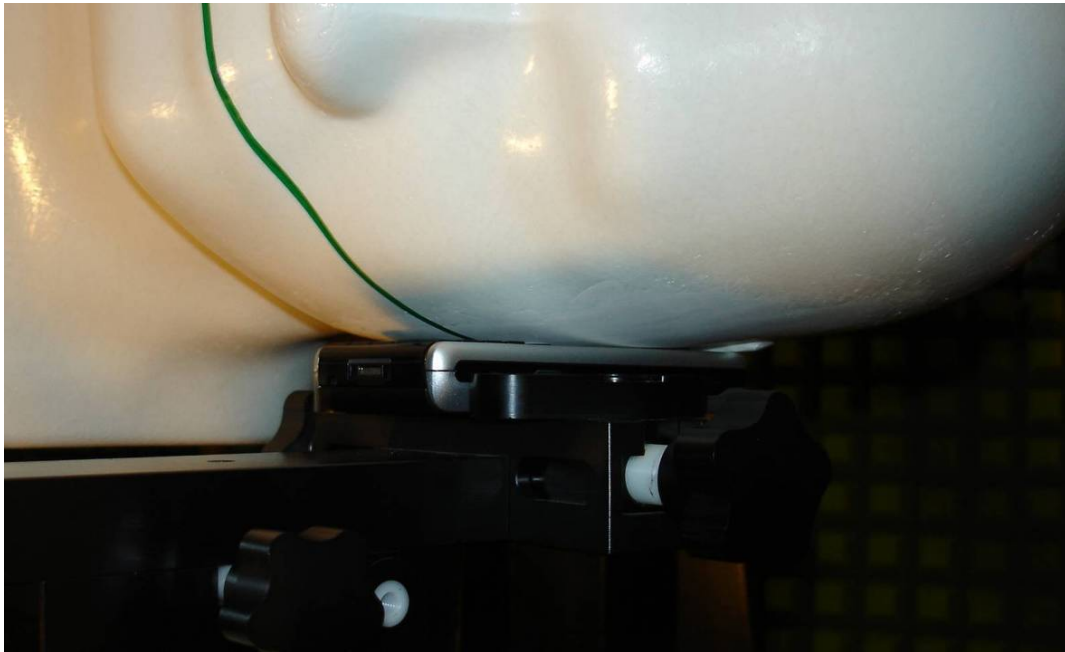

(a) Device on head phantom in the cheek position.



(b) Device on head phantom in the tilt position.



(c) Device on flat section of the phantom. The separation was 15 mm between the device and the flat phantom.

APPENDIX C: SAR distribution plots for the system performance checks**System performance check at 1900 MHz (Body) conducted April 4th**

Date/Time: 2007-04-04 10:40:55

-Communication System: CW; Frequency: 1900 MHz; Duty Cycle: 1:1
-Medium: Muscle 1900 MHz; $\sigma = 1.57$ mho/m; $\epsilon_r = 51.2$; $\rho = 1000$ kg/m³

DASY4 Configuration:

-Probe: ES3DV3 - SN3113; ConvF(4.7, 4.7, 4.7)

-Electronics: DAE3 Sn422

-Phantom: SAM 1; Serial: TP1390

-Measurement SW: DASY4, V4.7 Build 53; Postprocessing SW: SEMCAD, V1.8 Build 172

d=10mm, Pin= 249.5 mW/Area Scan (61x91x1): Measurement grid: dx=10mm, dy=10mm
Maximum value of SAR (interpolated) = 12.1 mW/g

d=10mm, Pin= 249.5 mW/Zoom Scan (5x5x7) (5x5x7)/Cube 0: Measurement grid: dx=8mm, dy=8mm,
dz=5mm

Reference Value = 81.9 V/m; Power Drift = 0.081 dB

Peak SAR (extrapolated) = 19.4 W/kg

SAR(1 g) = 10.4 mW/g; SAR(10 g) = 5.35 mW/g

Maximum value of SAR (measured) = 11.8 mW/g

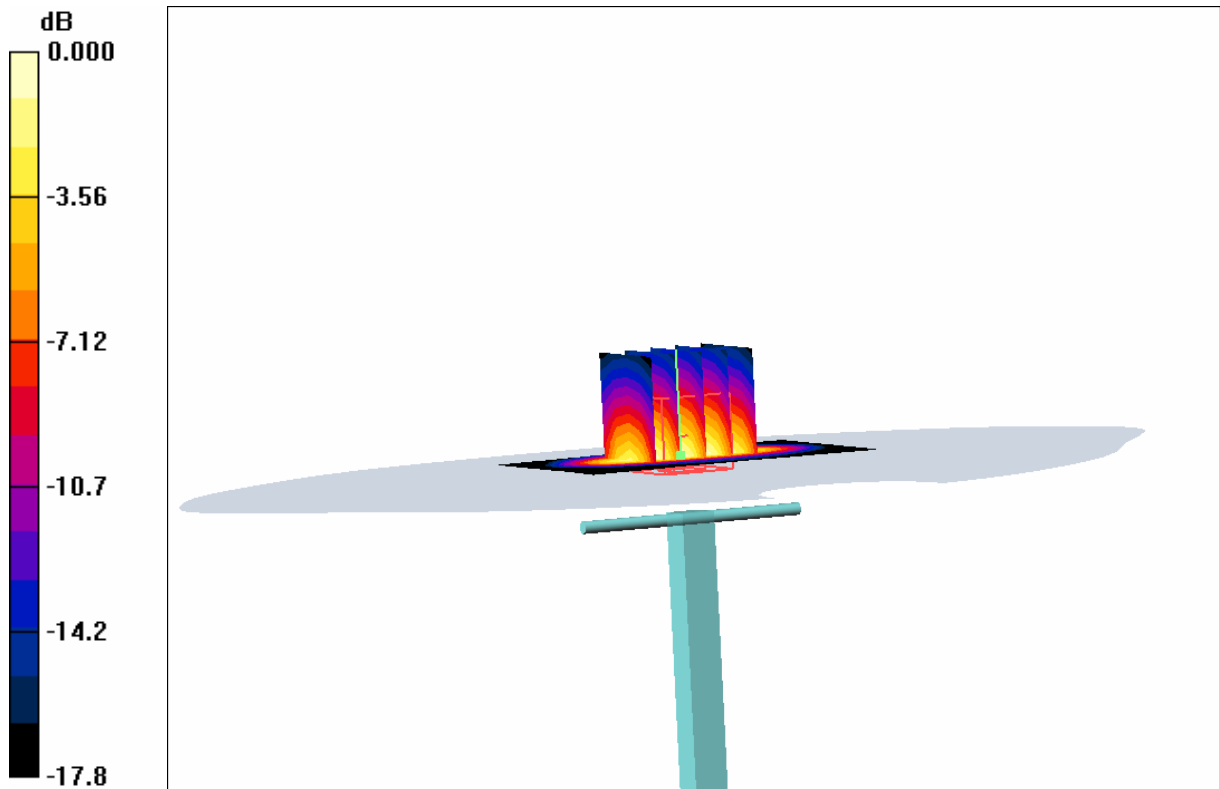

0 dB = 11.8mW/g

EAB-07:022495 Uen, Rev B, 2007-05-07

System performance check at 1900 MHz (Body) conducted April 5th

Date/Time: 2007-04-05 08:58:20

-Communication System: CW; Frequency: 1900 MHz; Duty Cycle: 1:1
-Medium: Muscle 1900 MHz; $\sigma = 1.59$ mho/m; $\epsilon_r = 51.3$; $\rho = 1000$ kg/m³

DASY4 Configuration:

-Probe: ES3DV3 - SN3113; ConvF(4.7, 4.7, 4.7)

-Electronics: DAE3 Sn422

-Phantom: SAM 1; Serial: TP1390

-Measurement SW: DASY4, V4.7 Build 53; Postprocessing SW: SEMCAD, V1.8 Build 172

d=10mm, Pin= 251.3 mW/Area Scan (61x91x1): Measurement grid: dx=10mm, dy=10mm
Maximum value of SAR (interpolated) = 12.4 mW/g

d=10mm, Pin= 251.3 mW/Zoom Scan (5x5x7) (5x5x7)/Cube 0: Measurement grid: dx=8mm, dy=8mm,
dz=5mm

Reference Value = 88.7 V/m; Power Drift = 0.025 dB

Peak SAR (extrapolated) = 19.8 W/kg

SAR(1 g) = 10.8 mW/g; SAR(10 g) = 5.57 mW/g

Maximum value of SAR (measured) = 12.1 mW/g

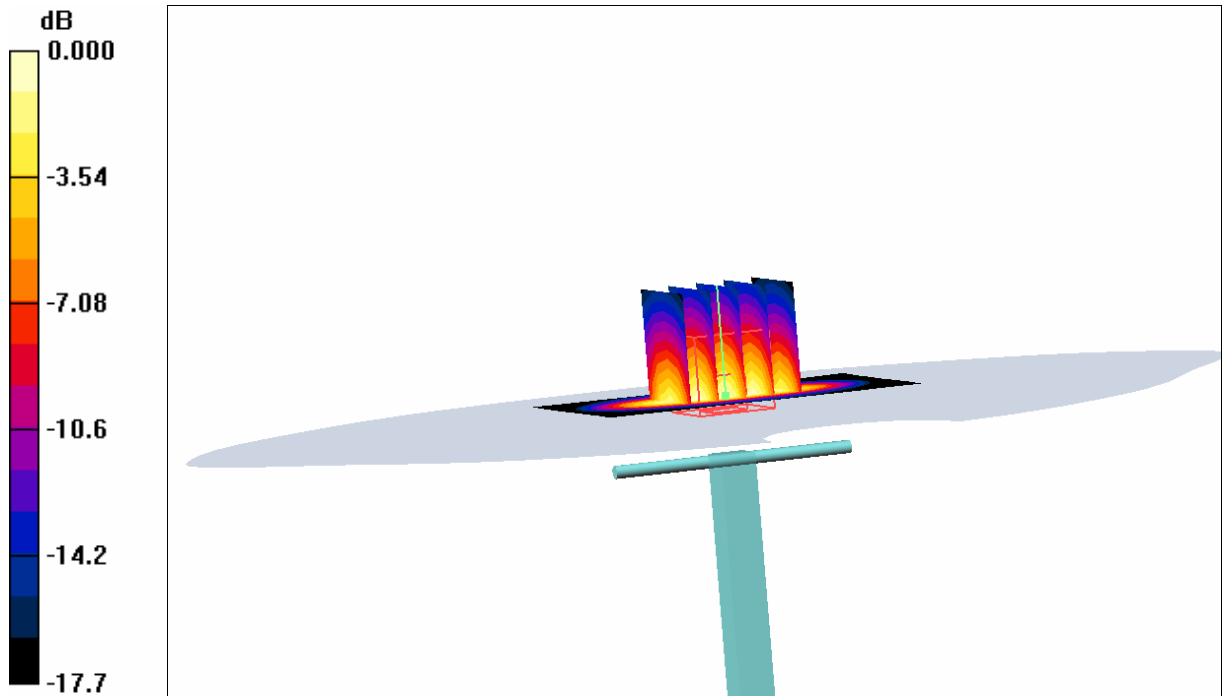

0 dB = 12.1mW/g

EAB-07:022495 Uen, Rev B, 2007-05-07

System performance check at 1900 MHz (Head) conducted April 5th

Date/Time: 2007-04-05 13:26:37

-Communication System: CW; Frequency: 1900 MHz; Duty Cycle: 1:1
-Medium: Head 1900 MHz; $\sigma = 1.39$ mho/m; $\epsilon_r = 38.7$; $\rho = 1000$ kg/m³

DASY4 Configuration:

-Probe: ES3DV3 - SN3113; ConvF(4.94, 4.94, 4.94)
-Electronics: DAE3 Sn422
-Phantom: SAM 1; Serial: TP1390
-Measurement SW: DASY4, V4.7 Build 53; Postprocessing SW: SEMCAD, V1.8 Build 172

d=10mm, Pin= 251.7 mW/Area Scan (61x91x1): Measurement grid: dx=10mm, dy=10mm
Maximum value of SAR (interpolated) = 11.4 mW/g

d=10mm, Pin= 251.7 mW/Zoom Scan (5x5x7) (5x5x7)/Cube 0: Measurement grid: dx=8mm, dy=8mm, dz=5mm

Reference Value = 89.6 V/m; Power Drift = -0.020 dB

Peak SAR (extrapolated) = 18.3 W/kg

SAR(1 g) = 9.98 mW/g; SAR(10 g) = 5.23 mW/g

Maximum value of SAR (measured) = 11.2 mW/g

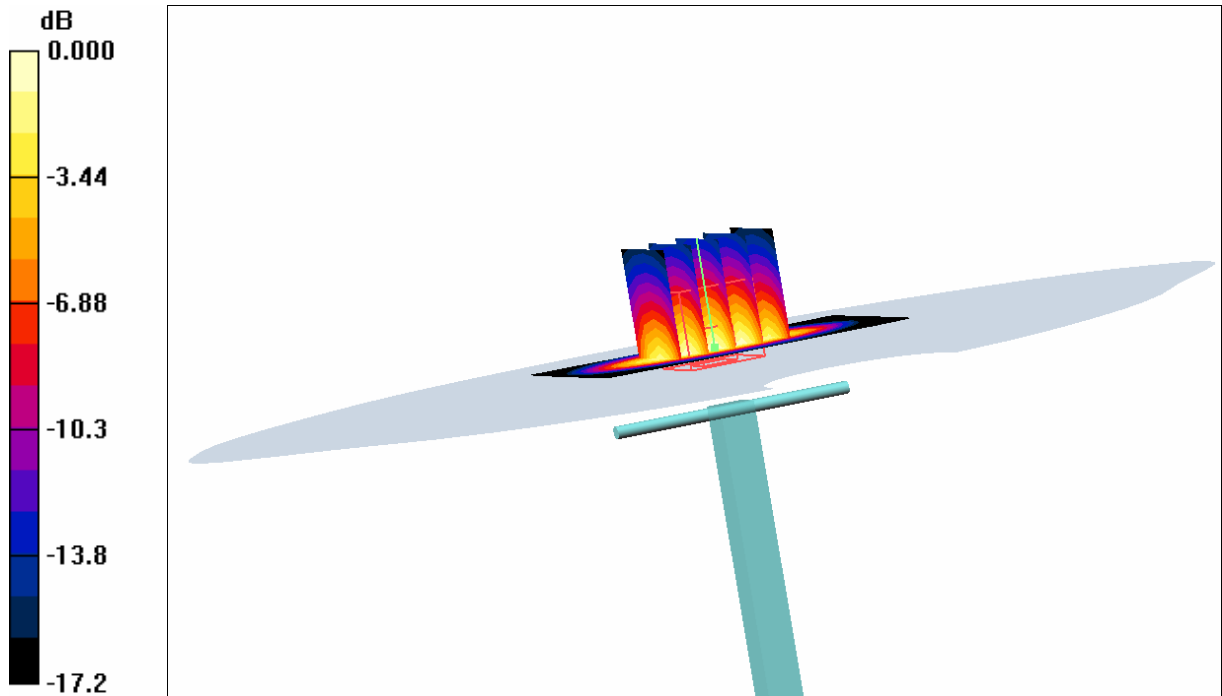

0 dB = 11.2mW/g

APPENDIX D: SAR distribution plots

Date/Time: 2007-04-05 14:24:50

-Communication System: GSM 1900; Frequency: 1880 MHz; Duty Cycle: 1:8.3
-Medium: Head 1900 MHz; $\sigma = 1.39$ mho/m; $\epsilon_r = 38.7$; $\rho = 1000$ kg/m³

DASY4 Configuration:

-Probe: ES3DV3 - SN3113; ConvF(4.94, 4.94, 4.94)
-Electronics: DAE3 Sn422
-Phantom: SAM I; Serial: TP1390
-Measurement SW: DASY4, V4.7 Build 53; Postprocessing SW: SEMCAD, V1.8 Build 172

Cheek Mid/Area Scan (81x51x1): Measurement grid: dx=15mm, dy=15mm

Maximum value of SAR (interpolated) = 0.568 mW/g

Cheek Mid/Zoom Scan 5x5x7 (5x5x7)/Cube 0: Measurement grid: dx=8mm, dy=8mm, dz=5mm

Reference Value = 18.5 V/m; Power Drift = -0.030 dB

Peak SAR (extrapolated) = 0.808 W/kg

SAR(1 g) = 0.51 mW/g; SAR(10 g) = 0.32 mW/g

Maximum value of SAR (measured) = 0.539 mW/g

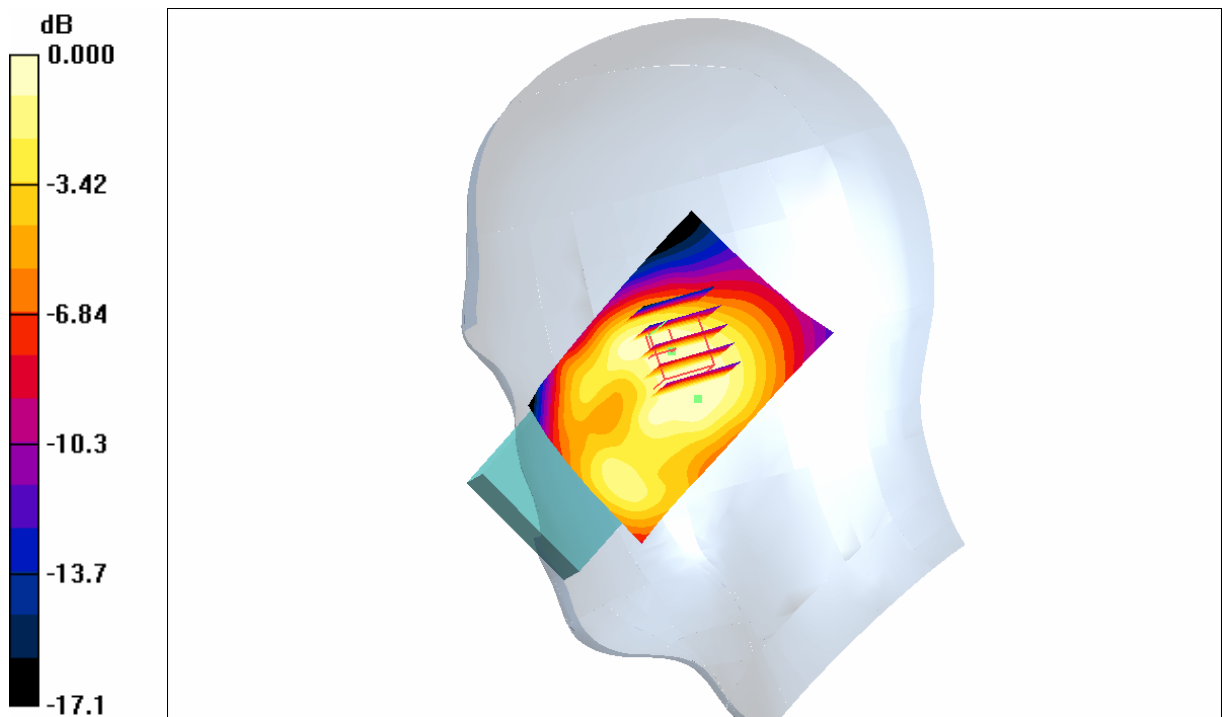

0 dB = 0.539mW/g

(a) SAR Distribution for EUT in GSM1900 mode measured against the right hand side phantom for the cheek phone position.

EAB-07:022495 Uen, Rev B, 2007-05-07

Date/Time: 2007-04-05 14:49:27

-Communication System: GSM 1900; Frequency: 1880 MHz; Duty Cycle: 1:8.3
-Medium: Head 1900 MHz; $\sigma = 1.39$ mho/m; $\epsilon_r = 38.7$; $\rho = 1000$ kg/m³

DASY4 Configuration:

-Probe: ES3DV3 - SN3113; ConvF(4.94, 4.94, 4.94)
-Electronics: DAE3 Sn422
-Phantom: SAM 1; Serial: TP1390
-Measurement SW: DASY4, V4.7 Build 53; Postprocessing SW: SEMCAD, V1.8 Build 172

Tilt Mid/Area Scan (81x51x1): Measurement grid: dx=15mm, dy=15mm

Maximum value of SAR (interpolated) = 0.852 mW/g

Tilt Mid/Zoom Scan 5x5x7 (5x5x7)/Cube 0: Measurement grid: dx=8mm, dy=8mm, dz=5mm

Reference Value = 24.8 V/m; Power Drift = -0.045 dB

Peak SAR (extrapolated) = 1.20 W/kg

SAR(1 g) = 0.76 mW/g; SAR(10 g) = 0.45 mW/g

Maximum value of SAR (measured) = 0.842 mW/g

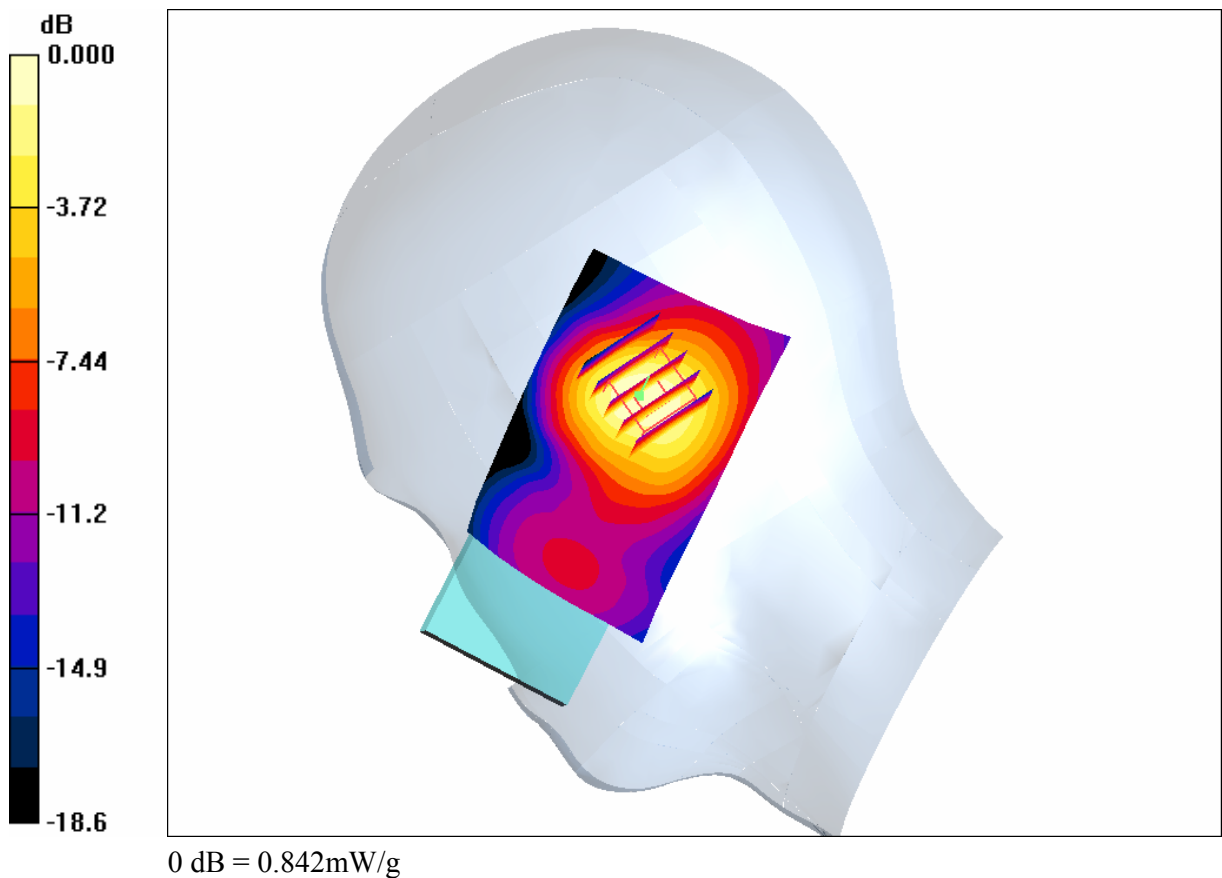

(b) SAR Distribution for EUT in GSM1900 mode measured against the right hand side phantom for the tilt phone position.

EAB-07:022495 Uen, Rev B, 2007-05-07

Date/Time: 2007-04-05 16:09:44

-Communication System: GSM 1900; Frequency: 1880 MHz; Duty Cycle: 1:8.3
-Medium: Head 1900 MHz; $\sigma = 1.39$ mho/m; $\epsilon_r = 38.7$; $\rho = 1000$ kg/m³

DASY4 Configuration:

-Probe: ES3DV3 - SN3113; ConvF(4.94, 4.94, 4.94)
-Electronics: DAE3 Sn422
-Phantom: SAM 1; Serial: TP1390
-Measurement SW: DASY4, V4.7 Build 53; Postprocessing SW: SEMCAD, V1.8 Build 172

Cheek Mid, no pen/Area Scan (81x51x1): Measurement grid: dx=15mm, dy=15mm

Maximum value of SAR (interpolated) = 1.09 mW/g

Cheek Mid, no pen/Zoom Scan 5x5x7 (5x5x7)/Cube 0: Measurement grid: dx=8mm, dy=8mm, dz=5mm

Reference Value = 21.5 V/m; Power Drift = -0.093 dB

Peak SAR (extrapolated) = 1.71 W/kg

SAR(1 g) = 1.02 mW/g; SAR(10 g) = 0.59 mW/g

Maximum value of SAR (measured) = 1.14 mW/g

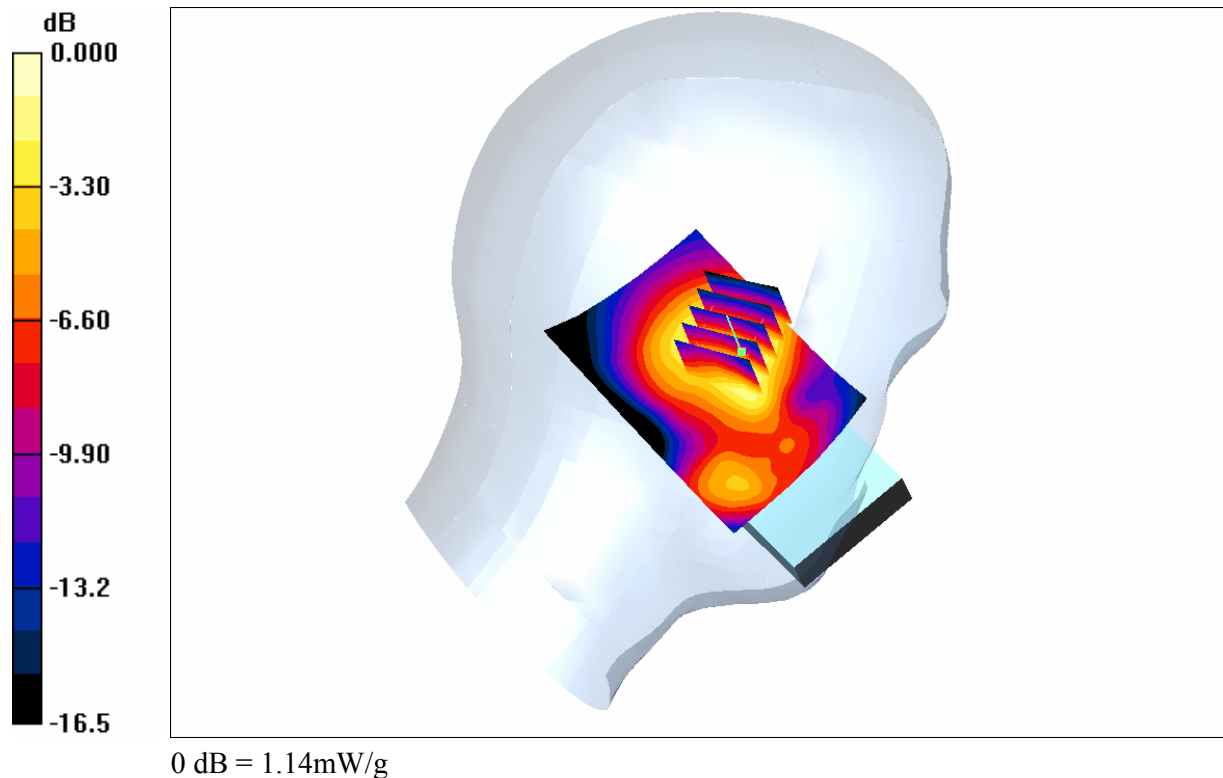

(c) Maximum SAR Distribution for EUT in GSM1900 mode measured against the left hand side phantom for the cheek phone position.

EAB-07:022495 Uen, Rev B, 2007-05-07

Date/Time: 2007-04-05 15:29:49

-Communication System: GSM 1900; Frequency: 1880 MHz; Duty Cycle: 1:8.3
-Medium: Head 1900 MHz; $\sigma = 1.39$ mho/m; $\epsilon_r = 38.7$; $\rho = 1000$ kg/m³

DASY4 Configuration:

-Probe: ES3DV3 - SN3113; ConvF(4.94, 4.94, 4.94)
-Electronics: DAE3 Sn422
-Phantom: SAM 1; Serial: TP1390
-Measurement SW: DASY4, V4.7 Build 53; Postprocessing SW: SEMCAD, V1.8 Build 172

Tilt Mid/Area Scan (81x51x1): Measurement grid: dx=15mm, dy=15mm

Maximum value of SAR (interpolated) = 0.858 mW/g

Tilt Mid/Zoom Scan 5x5x7 (5x5x7)/Cube 0: Measurement grid: dx=8mm, dy=8mm, dz=5mm

Reference Value = 25.0 V/m; Power Drift = -0.067 dB

Peak SAR (extrapolated) = 1.32 W/kg

SAR(1 g) = 0.80 mW/g; SAR(10 g) = 0.48 mW/g

Maximum value of SAR (measured) = 0.882 mW/g

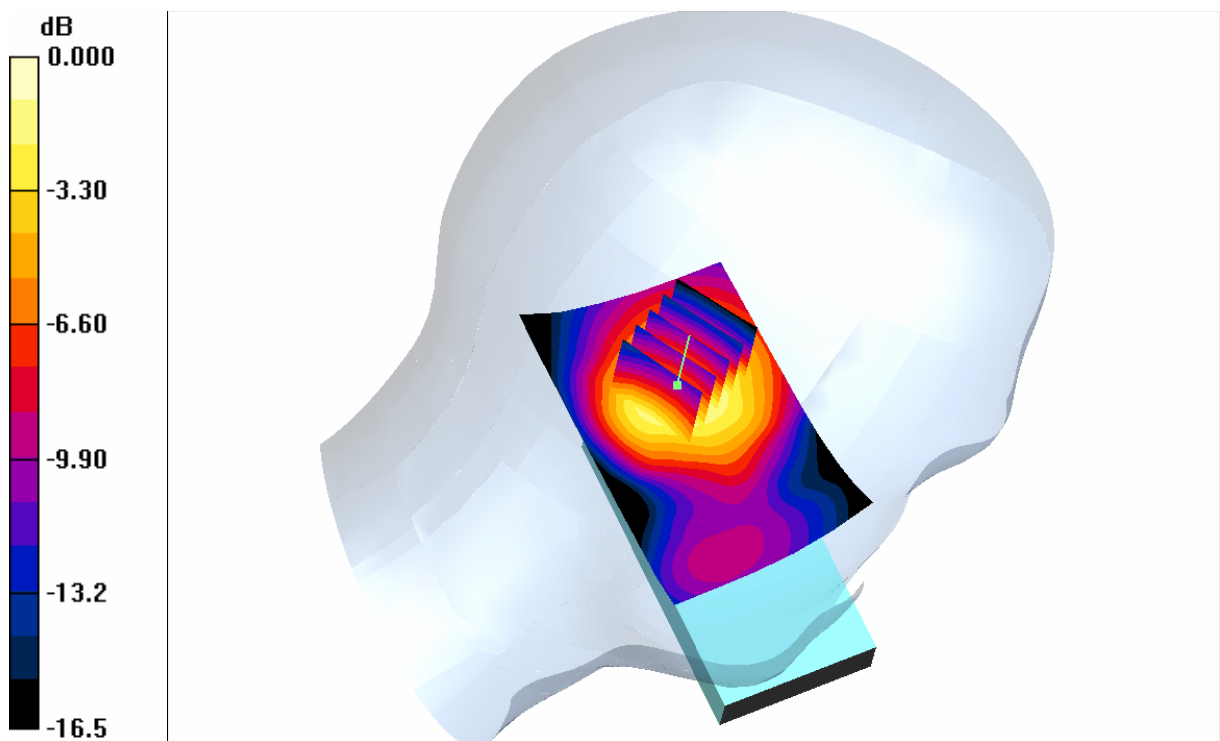

(d) SAR Distribution for EUT in GSM1900 mode measured against the left hand side phantom for the tilt phone position.

EAB-07:022495 Uen, Rev B, 2007-05-07

Date/Time: 2007-04-04 15:15:51

-Communication System: GSM 1900; Frequency: 1909.8 MHz; Duty Cycle: 1:8.3
-Medium: Muscle 1900 MHz; $\sigma = 1.57$ mho/m; $\epsilon_r = 51.2$; $\rho = 1000$ kg/m³

DASY4 Configuration:

-Probe: ES3DV3 - SN3113; ConvF(4.7, 4.7, 4.7)

-Electronics: DAE3 Sn422

-Phantom: SAM 1; Serial: TP1390

-Measurement SW: DASY4, V4.7 Build 53; Postprocessing SW: SEMCAD, V1.8 Build 172

Back to phantom, High, no pen/Area Scan (51x91x1): Measurement grid: dx=15mm, dy=15mm
Maximum value of SAR (interpolated) = 1.28 mW/g

Back to phantom, High, no pen/Zoom Scan (5x5x7)/Cube 0: Measurement grid: dx=8mm, dy=8mm,
dz=5mm

Reference Value = 12.1 V/m; Power Drift = -0.071 dB

Peak SAR (extrapolated) = 1.94 W/kg

SAR(1 g) = 1.14 mW/g; SAR(10 g) = 0.65 mW/g

Maximum value of SAR (measured) = 1.26 mW/g

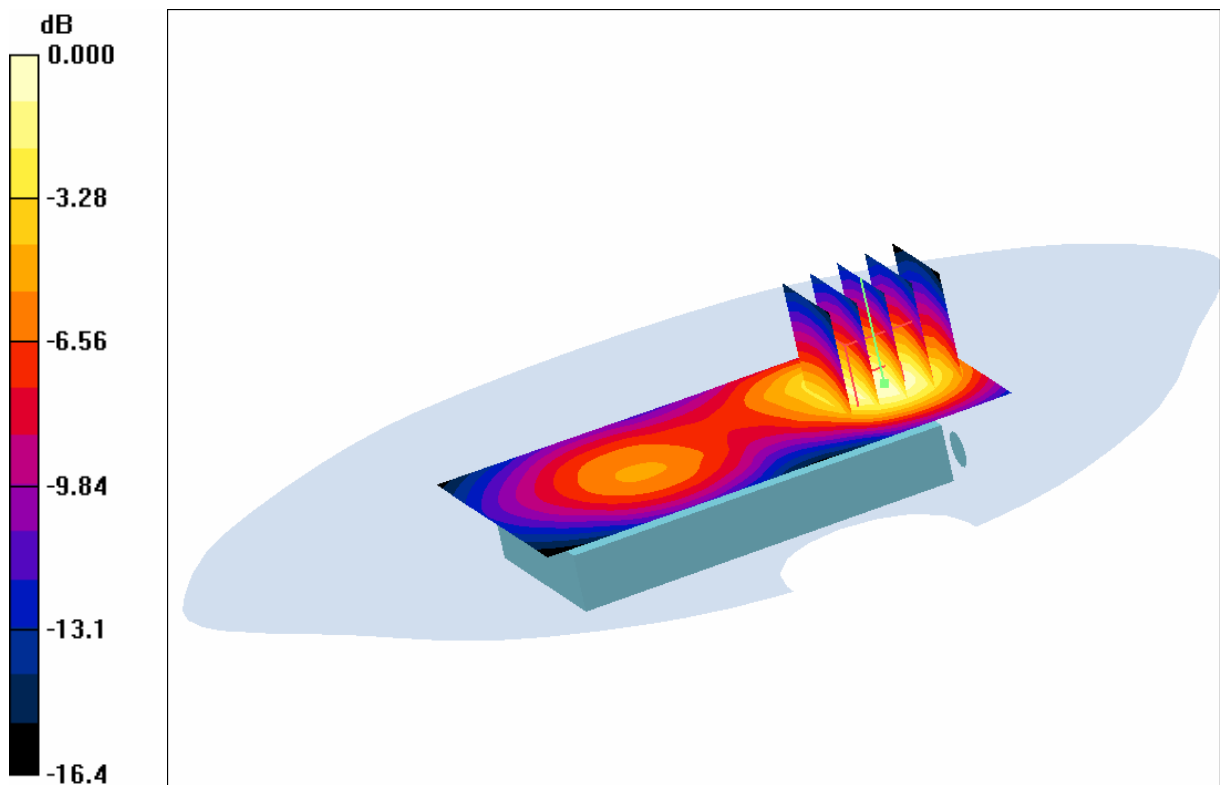

0 dB = 1.26mW/g

(e) Maximum SAR Distribution for EUT in GSM1900 mode measured with the back of the phone facing the flat section of phantom.

EAB-07:022495 Uen, Rev B, 2007-05-07

Date/Time: 2007-04-05 10:19:48

-Communication System: GSM 1900; Frequency: 1909.8 MHz; Duty Cycle: 1:4.15
-Medium: Muscle 1900 MHz; $\sigma = 1.59$ mho/m; $\epsilon_r = 51.3$; $\rho = 1000$ kg/m³

DASY4 Configuration:

-Probe: ES3DV3 - SN3113; ConvF(4.7, 4.7, 4.7)

-Electronics: DAE3 Sn422

-Phantom: SAM 1; Serial: TP1390

-Measurement SW: DASY4, V4.7 Build 53; Postprocessing SW: SEMCAD, V1.8 Build 172

Back to phantom, High, no pen/Area Scan (51x91x1): Measurement grid: dx=15mm, dy=15mm
Maximum value of SAR (interpolated) = 1.42 mW/g

Back to phantom, High, no pen/Zoom Scan (5x5x7)/Cube 0: Measurement grid: dx=8mm, dy=8mm,
dz=5mm

Reference Value = 13.2 V/m; Power Drift = -0.096 dB

Peak SAR (extrapolated) = 2.20 W/kg

SAR(1 g) = 1.28 mW/g; SAR(10 g) = 0.73 mW/g

Maximum value of SAR (measured) = 1.42 mW/g

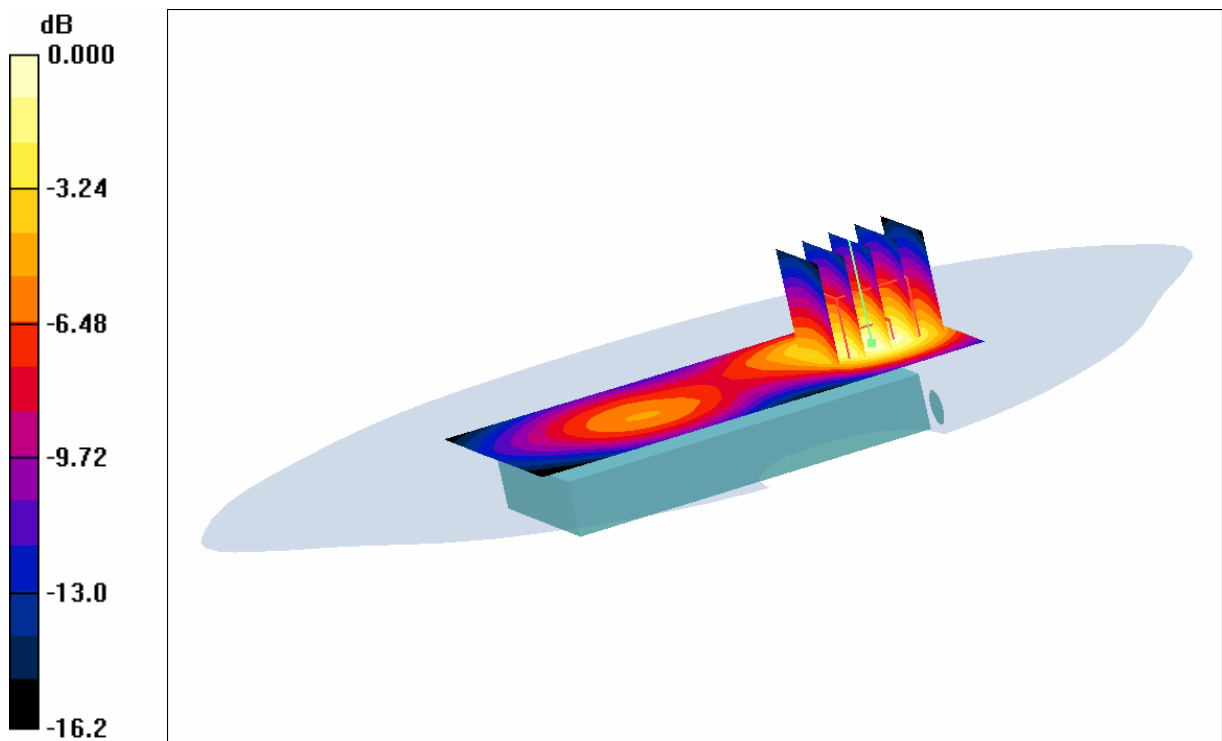

(f) Maximum SAR Distribution for EUT in GPRS(2Tx)1900 mode measured with the back of the phone facing the flat section of phantom.

APPENDIX E: Probe calibration parameters for ES3DV3, S/N: 3113
Diode compression:

Parameter	Value in mV
DCP X	95
DCP Y	95
DCP Z	95

Sensitivity in free space:

Parameter	Value in $\mu\text{V}/(\text{V/m})^2$
Norm X	1.20
Norm Y	1.10
Norm Z	1.28

Sensitivity in tissue simulating liquid

Head 1900 MHz; $\epsilon_r=40 \pm 5\%$, $\sigma=1.40 \pm 5\%$ S/m.

Parameter	Value
ConvF X	4.94
ConvF Y	4.94
ConvF Z	4.94

Muscle 1900 MHz; $\epsilon_r=53.3 \pm 5\%$, $\sigma=1.52 \pm 5\%$ S/m.

Parameter	Value
ConvF X	4.70
ConvF Y	4.70
ConvF Z	4.70

Probe tip to sensor center: 2.7 mm