

Prepared (also subject responsible if other)

GBFA/SEM/BMD/TP Pam Wood

Approved

GBFA/SEM/BMD/U (Michael Bower)

Checked

 Confidential
 MARKING DRAWING

No.

151 86 - KRD 104 1030 Uen

Date

2006-02-16

Rev

A

Reference

151 86-KRD 104 1030 Rev A.doc

Marking Drawing Type 1051022-BV series

Label

The label used for marking is defined in the Manufacturing Specification on the SVF 930 2460.

Placing

The label shall be placed on the back of the module according to the Assembly Drawing (151 88) for the KRD.

Print layout

Lines:

1

Sony Ericsson

2

IC: 4170B-BC051022

3

FCC ID: PY7BC051022

4



5

IMEI: 00000000-000000-0

6

TYPE BAC-1051022-BV

7a, b

KRD 104 1030/XXX Rxx

GS64

8a, b

Made in xxxxxx

yyWww

9

CE 0682

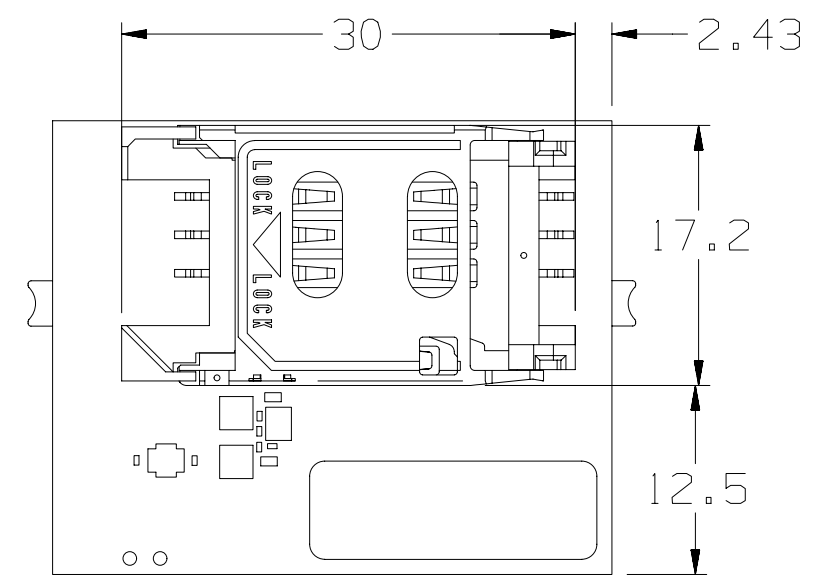
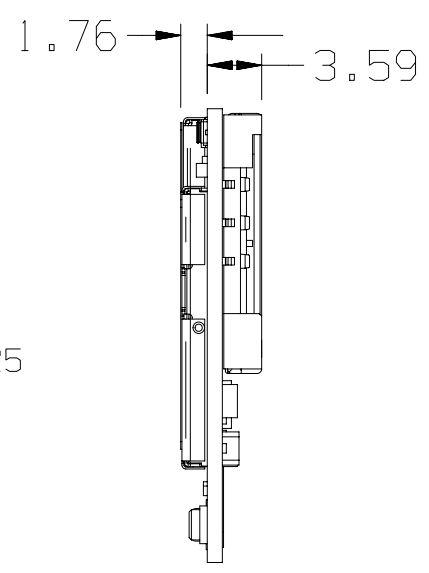
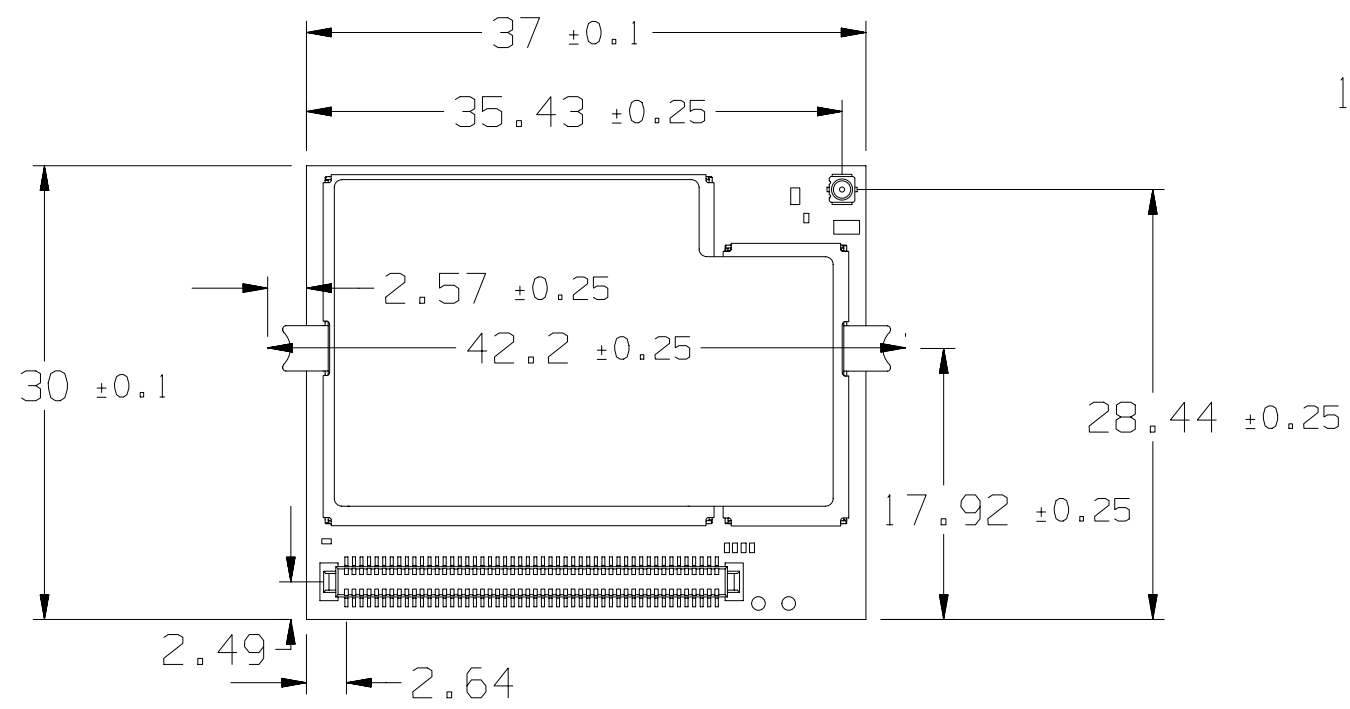

Sony Ericsson		Prepared (Also Subject Responsible If Other) JAMIE SHIFELTT SEM/B/M/D	
Drawing Rules ISO		Doc Responsible/Approved CURT THORNTON SEM/B/M/D	Date 04/04/06
Tolerance X.XX ± .20		Rev A	
Reference		Product Name QUAD BAND GPRS CORE, GS64	
Scale	Units mm	Size A3	Document No. 15188 - KRD 104 1030/50
			Sheet 1 (1)

CONFIDENTIAL

Confidential

Prepared (also subject responsible if other)

GBFA/SEM/BMD/TP Pam Wood

Approved

GBFA/SEM/BMD/U (Michael Bower)

Checked

No.

151 86 - KRD 104 1030 Uen

Date

2006-02-16

Rev

A

Reference

151 86-KRD 104 1030 Rev

Definitions

Line	1	Sony Ericsson trademark
	2	Industry Canada marking
	3	FCC approval marking
	4	IMEI number as bar code
	5	IMEI number as characters
	6	Type number
	7a	KRD number, R-state
	7b	Product Name "GS64"
	8a	Marking of origin
	8b	Production Week as bar code
	9	Approval Mark

Sony Ericsson trademark Sony Ericsson and the Sony Ericsson trademark shall be according to the corporate standard 190 89-EN/LZT 108 5347. Height min. 2 mm.

Industry Canada marking Industry Canada approval marking: consists of text:

IC: 4170B-BC051022

Approval marks FCC approval marking: consists of the text:

FCC ID: PY7BC051022

Within a frame with height > 1.5 mm.

IMEI number as bar code See below for definition of IMEI-number. The bar code shall only contain the digits of the IMEI number (no -).

IMEI number as characters

The IMEI number has format:
TAC - SNR - CD

TAC = First eight digits of the Type Approval code after assignment from the Notified Body. Refer to table 1 below.

SNR = A serial number from 000 000 to 999 999 according to factory allocation. Refer to table 1 below.

CD = A check digit, from 0-9, calculated according to the Luhn formula (ISO/IEC 7812), GSM 02.16.

Confidential

Prepared (also subject responsible if other)

GBFA/SEM/BMD/TP Pam Wood

Approved

GBFA/SEM/BMD/U (Michael Bower)

Checked

No.

151 86 - KRD 104 1030 Uen

Date

Rev

Reference

2006-02-16

A

151 86-KRD 104 1030 Rev

Type number	The type number is BAC-1051022-xx and shall be printed "Type BAC-1051022-xx". Refer to table 1 below.
KRD number	The KRD number for the product (including any variant number e.g. "/12"). Refer to table 1 below.
R-state	The R-state for the KRD according to the 1095 for the KRD.
Product Name	Text "GS64". Type Size 1.5mm (min).
Manufacturing country	Marking of origin shall be printed "Made in Mexico" for modules produced in Celestica. "Made in Taiwan" for modules produced in Tecom.
Production week	The production week shall be given as yyWww (yy = year, ww = week)

Table 1

<u>KRD variant</u>	<u>Type Number</u>	<u>IMEI TAC code</u>	<u>IMEI SNR</u>	<u>Allocated factory</u>
/ 10	BAC-1051022-AA	tbd	000000 to 099999	tbd
/ 20	BAC-1051022-AB	tbd	000000 to 099999	tbd
/ 40	BAC-1051022-CA	tbd	000000 to 099999	tbd
/ 50	BAC-1051022-CB	tbd	000000 to 099999	tbd



Confidential

Prepared (also subject responsible if other)

GBFA/SEM/BMD/TP Pam Wood

Approved

GBFA/SEM/BMD/U (Michael Bower)

Checked

No.

151 86 - KRD 104 1030 Uen

Date

2006-02-16

Rev

A

Reference

151 86-KRD 104 1030 Rev

Print regulations

The printing shall be legible and permanent.

Other texts, which are not defined above, have the following characteristics:

Typeface:	ZPL II standard font D
Type size:	min 1.1 mm
Line spacing:	min 1.5 mm
Trademark:	min 1.5 mm
Approval marks:	min 5.0 mm

Confidential

Prepared (also subject responsible if other)

GBFA/SEM/BMD/TP Pam Wood

Approved

GBFA/SEM/BMD/U (Michael Bower)

Checked

No.

151 86 - KRD 104 1030 Uen

Date

2006-02-16

Rev

A

Reference

151 86-KRD 104 1030 Rev

Print layout for prototypes

Line 2 is replaced with text with alternative shown below. Type size min. 5 mm.

PROTOTYPE EP1
 PROTOTYPE EP2
 PROTOTYPE FP1
 PROTOTYPE FP2 etc.

Note: Refer to build Exemption and/or the Build Entry Request (BER) for the proper naming convention for the prototype Build.

Line 3 is replaced with text "NOT FCC or TYPE APPROVED". Text height min 2 mm.

Line 4 and 5: IMEI-numbers as barcode and IMEI-numbers as characters shall be filled with the **test** IMEI number.

The test IMEI number is in the following ranges:

from 00460101-777000 to 00460101-778999

00460101-960000 to 00460101-961999

(the CD number must be added)

Line 9 is left blank

Lines:

1

Sony Ericsson

2

PROTOTYPE XXX

9

3

NOT FCC or TYPE APPROVED

4



5

IMEI:00000000-000000-0

6

TYPE BAC-1051022-BV

7a, b

KRD 104 1030/XXX Rxx

GS64

8a, b

Made in XXXXXX

yyWww