

TEST REPORT
No.: 2-0004-11-18-1a

According to:
FCC-Regulations
Part 22 & Part 24
IC-Regulations
RSS-132 Issue 2 & RSS-133 Issue 5
RSS-Gen, Issue 3

for

Sony Ericsson Mobile Communications AB

GSM/(E)GPRS/W-CDMA Mobile Phone AAD-3880121-BV

FCC-ID: PY7A3880121
IC: 4170B-A3880121







Laboratory Accreditation and Listings			
 DAkKS Deutsche Akkreditierungsstelle D-PL-12047-01-01	 FEDERAL COMMUNICATIONS COMMISSION USA Reg. No.: 736496 MRA US-EU 0003	 Industry Canada Reg. No.: 3462D-1 Reg. No.: 3462D-2 Reg. No.: 3462D-3	 Voluntary Controls for Electromagnetic Emissions Reg. No.: R-2665, R-2666 C-2914, T-1967, G-301
 WiFi ALLIANCE AUTHORIZED RF LABORATORY	 CTIA Authorized Test Lab LAB CODE 20011130-00		
accredited according to DIN EN ISO/IEC 17025			
<p>CETECOM GmbH Laboratory Radio Communications & Electromagnetic Compatibility Im Teelbruch 116 • 45219 Essen • Germany Registered in Essen, Germany, Reg. No.: HRB Essen 8984 Tel.: + 49 (0) 20 54 / 95 19-954 • Fax: + 49 (0) 20 54 / 95 19-964 E-mail: info@cetecom.com • Internet: www.cetecom.com</p>			

Table of contents

1. SUMMARY OF TEST RESULTS.....	3
1.1. TESTS OVERVIEW FCC Part 15/22/24 and Canada IC Standards (RSS)	3
2. ADMINISTRATIVE DATA	5
2.1. Identification of the testing laboratory	5
2.2. Test location	5
2.3. Organizational items	5
2.4. Applicant’s details	5
2.5. Manufacturer’s details	5
3. EQUIPMENT UNDER TEST (EUT).....	6
3.1. Additional declaration and description of main EUT	6
3.2. EUT: Type, S/N etc. and short descriptions used in this test report	7
3.3. Auxiliary Equipment (AE): Type, S/N etc. and short descriptions	7
3.4. EUT set-ups	7
3.5. EUT operating modes	8
3.6. Parameter Settings on mobile phone and base station CMU200	9
4. DESCRIPTION OF TEST SET-UP’S.....	10
4.1. Mode Test Set-up for conducted measurements	10
4.2. Test set-up for radiated measurements	11
5. MEASUREMENTS	12
5.1. RF power output (Conducted and Radiated)	12
5.2. Occupied and emission bandwidth	16
5.3. Emission limits (Spurious emission conducted and radiated).....	18
5.4. Radiated field strength emissions below 30 MHz	25
5.5. Frequency stability on temperature and voltage variations.....	27
6. MEASUREMENT UNCERTAINTIES.....	36
7. CORRECTION FACTORS DUE TO REDUCED MEAS. DISTANCE (F< 30 MHZ).....	37
8. INSTRUMENTS AND ANCILLARY	38
8.1. Used equipment “CTC”	38

Table of annex

	Total pages
SEPARATE DOCUMENT TR2-0004-11-18-1A_A1.PDF: DIAGRAMS OF TESTING	77
SEPARATE DOCUMENT TR2-0004-11-18-1A_A2.PDF: EXTERNAL PHOTOS OF EUT	8
SEPARATE DOCUMENT TR2-0004-11-18-1A_A3.PDF: TEST SET-UP PHOTOS	4
SEPARATE DOCUMENT TR2-0004-11-18-1A_A4.PDF: INTERNAL EUT PHOTOS	5

1. Summary of test results

The test results apply exclusively to the test samples as presented in chapter 3.1. The CETECOM GmbH does not assume responsibility for any conclusions and generalizations taken in conjunction with other specimens or samples of the type of the item presented to tests.

The presented mobile phone type AAD-3880121-BV includes GSM/(E)GPRS and W-CDMA Band I and VIII technology. This test report shows results for GSM and (E)GPRS technology only.

Following tests have been performed to show compliance with applicable FCC Part 2, Part 22, Subpart H and Part 24, Subpart E (Broadband PCS) of the FCC CFR 47 Rules, Edition 1st October 2010.

1.1. TESTS OVERVIEW FCC Part 15/22/24 and Canada IC Standards (RSS)

TEST CASES	PORT	REFERENCES & LIMITS			EUT set-up	EUT operating mode	Result
		FCC Standard	RSS Section	TEST LIMIT			
TX-Mode							
RF POWER (conducted)	Antenna terminal (conducted)	§2.1046	--	N/A	2	2+3+5+6	Passed
RF-POWER radiated (ERP/EIRP)	Cabinet	§2.1046 §22.913(a)(2) §24.232(c)	RSS-132: 4.4 SRSP-503: 5.1.3 RSS-133:4.1/6.4 SRSP-510: 5.1.2	< 7 Watt (ERP) < 2 Watt (EIRP)	1	2+3+5+6	Passed
SPURIOUS EMISSIONS (conducted)	Antenna terminal (conducted)	§2.1051 §2.1057 §22.917(a)(b) §24.238(a)(b)	RSS 132: 4.5.1 RSS 133: 6.5.1(a)(b)	43+10log(P) dBc	2	2+5	Passed
EMISSION BANDWIDTH & 99% OCCUPIED BANDWIDTH	Antenna terminal (conducted)	§2.202 §2.1049 §22.917(a) §24.238(a)	RSS Gen:4.6.1	99% Power	2	2+3+5+6	Passed
SPURIOUS EMISSIONS (radiated)	Cabinet + Interconnecting cables (radiated)	§15.209(a)	RSS-Gen: 4.11	2400/F(kHz) µV/m 24000/F(kHz) µV/m 30 µV/m	1	2+7	Passed
		§2.1053(a) §2.1057 §22.917(a)(b) §24.238(a)(b)	RSS-132: 4.5.1 & 4.5.2 RSS 133: 6.5.1(a)(b)	43+10log(P) dBc	1	2+5+7	Passed
FREQUENCY STABILITY	Antenna terminal (conducted)	§22.355, table C-1 §24.235 §2.1055(a)(2)	RSS-132: 4.3 RSS 133: 6.3	< ±2.5ppm <±0.1 ppm	2	2+3+5+6	Passed
AC-Power Lines Conducted Emissions	AC-Power lines	§15.207	RSS-Gen, Issue 3: Chapter 7.2.4	FCC §15.107 class B limits §15.207 limits IC: Table 4, Chapter 7.2.4	1	2+5+7	Passed Remark 1

RX Mode							
AC-Power Lines Conducted Emissions	AC-Power lines	§15.107 §15.207	RSS-Gen, Issue 3: Chapter 7.2.4	FCC §15.107 class B limits §15.207 limits IC: Table 4, Chapter 7.2.4	1	1+4+7	Passed Remark 1
RECEIVER Radiated emissions	Cabinet + Interconnecting cables (radiated)	§15.109 §15.33 §15.35	RSS-132, Issue 2: 4.6 RSS-Gen, Issue 3: 6.1 RSS 133, Issue 5: 6.6	FCC 15.109 class B limits IC-limits: Table 1, Chapter 6	1	1+4+7	Passed Remark 1
RECEIVER Conducted emissions	Antenna terminal (conducted)	§2.1051	RSS-Gen: 6.2 RSS132: 4.6 RSS133: 6.7(b)	43+10log(P) dBc IC: < 2 nW/4kHz (30<f<1000MHz) < 5nW/4kHz (f> 1GHz)	--	--	N/A

Remark: 1.) See separate test report TR2-0004-11-18-1g for measurements according Part 15, Subpart B.

ATTESTATION:

I declare that all measurements were performed by me or under my supervision and that all measurements have been performed and are correct to my best knowledge and belief to Industry Canada standards. All requirements as shown in above table are met in accordance with enumerated standards.

.....
Dipl.-Ing. W. Richter
Responsible for test section



GmbH
Im Teelbruch 116
45219 Essen
Tel.: + 49 (0) 20 54 / 95 19 - 0
Fax: + 49 (0) 20 54 / 95 19 - 997

.....
Dipl.-Ing. C. Lorenz
Responsible for test report

2. Administrative Data

2.1. Identification of the testing laboratory

Company name:	CETECOM GmbH
Address:	Im Teelbruch 116 45219 Essen - Kettwig Germany
Responsible for testing laboratory:	Dipl.-Ing. W. Richter
Deputy:	Dipl.-Ing. J. Schmitt
Laboratory accreditations/Listings:	DAkkS-Registration No. D-PL-12047-01-01 FCC-Registration No.: 736496, MRA US-EU 0003 IC-Registration No. 3462D-1, 3462D-2, 3462D-3 VCCI Reg. No. R-2665, R-2666, C-2914, T-1967, G-301

2.2. Test location

2.2.1. Test laboratory "CTC"

Company name:	see chapter 2.1. Identification of the testing laboratory
---------------	---

2.3. Organizational items

Order No.:	2-0004-11-18
Responsible for test report and project leader:	Dipl.-Ing. C. Lorenz
Receipt of EUT:	2011-07-31
Date(s) of test:	2011-07-31 to 2011-08-31
Date of report:	2011-09-07

Version of template:	11.05 _All.Dotm

2.4. Applicant's details

Applicant's name:	Sony Ericsson Mobile Communications AB
Address:	Nya Vattentornet 22-188 Lund Sweden
Contact person:	Mr. Anders Nordlöf

2.5. Manufacturer's details

Manufacturer's name:	please see Applicant's details
Address:	please see Applicant's details

3. Equipment under test (EUT)

3.1. Additional declaration and description of main EUT

Main function	GSM/(E)GPRS/W-CDMA mobile phone		
Type	AAD-3880121-BV		
GSM Frequency range (US/Canada -bands)	GSM 850: 824 – 849MHz (Uplink), 869-894MHz (Downlink) GSM1900: 1850-1910MHz (Uplink), 1930-1990MHz (Downlink)		
Type of modulation	GMSK/8-PSK		
Number of channels (USA/Canada -bands)	GSM 850: 128 – 251, 125 channels GSM1900: 512 – 810, 300 channels		
EMISSION DESIGNATOR(S)	246KGXW (GSM850) 248KGXW (EDGE850) 243KG7W (GSM1900) 246KG7W (EDGE 1900)		
Antenna Type	<input checked="" type="checkbox"/> Integrated <input type="checkbox"/> External, no RF- connector <input type="checkbox"/> External, separate RF-connector		
Antenna Gain	No information		
MAX PEAK Output Power: GSM 850 Conducted	34.15		
EDGE850	26.75		
MAX PEAK Output Power: GSM 850 Radiated	30.62		
EDGE850	23.75		
MAX PEAK Output Power: GSM 1900 Conducted	30.85		
EDGE1900	27.78		
MAX PEAK Output Power: GSM 1900 Radiated	32.63		
EDGE1900	28.40		
FCC-ID	PY7A3880121		
IC	4170B-A3880121		
Installed option	<input checked="" type="checkbox"/> GSM900 and GSM1800 Bands (not usable in USA/Canada) <input checked="" type="checkbox"/> W-CDMA Band I and Band VIII (not usable in USA/Canada) <input checked="" type="checkbox"/> W-LAN, Bluetooth®, ANT+ wireless technologies <input checked="" type="checkbox"/> battery charging option <input checked="" type="checkbox"/> GPS (not tested within this test report) <input checked="" type="checkbox"/> FM-Radio (Receiver only)		
Power supply			
Special EMI components	--		
EUT sample type	<input type="checkbox"/> Production	<input checked="" type="checkbox"/> Pre-Production	<input type="checkbox"/> Engineering

3.2. EUT: Type, S/N etc. and short descriptions used in this test report

Short description*)	EUT	Type	S/N serial number	HW hardware status	SW software status
EUT A	GSM/(E)GPRS/W-CDMA Mobile Phone	AAD-3880121-BV	IMEI: (004402142783 459) (CB5A1EYWHH)	AP1	4.0.1.A.0.57 ATP R1A034
EUT B	GSM/(E)GPRS/W-CDMA Mobile Phone	AAD-3880121-BV	IMEI: (004402142783 350) (CB5A1EYWH2)	AP1	4.0.1.A.0.57 ATP R1A034
EUT C	AC-Charger	CAA-0002016-BV	#1	EP800	--
EUT D	USB cable	EC700	#1	--	--
EUT E	Battery Li-Io 1200mAh	EP500	1057114SWOE NS	11W03	--
EUT F	Headset	CCA-0004013	CTC#1	--	--

*) EUT short description is used to simplify the identification of the EUT in this test report.

3.3. Auxiliary Equipment (AE): Type, S/N etc. and short descriptions

AE short description *)	Auxiliary Equipment	Type	S/N serial number	HW hardware status	SW software status
AE 1	Dummy battery	For EUT A	#1	--	--

*) AE short description is used to simplify the identification of the auxiliary equipment in this test report.

3.4. EUT set-ups

EUT set-up no. *)	Combination of EUT and AE	Remarks
Set. 1	EUT A + EUT C + EUT D + EUT E + EUT F	Used for radiated RF tests
Set. 2	EUT B + AE1	Used for conducted RF tests

*) EUT set-up no. is used to simplify the identification of the EUT set-up in this test report.

3.5. EUT operating modes

EUT operating mode no. *)	Description of operating modes	Additional information
op. 1	GSM 850 Idle mode BCCH 50	The mobile station is synchronized to the Broadcast Control Channel (BCCH) and listening to the Common Control Channel (CCCH). Periodic location update is disabled.
op. 2	GSM 850 TCH mode TCH=128/192/251	A communication link is established between the mobile station and the test simulator. The transmitter is operated at its maximum rated output power: 33 dBm (power class 4; power control level 5). The input signal to the receiver is modulated with normal test modulation. The wanted RF input signal level to the receiver of the mobile station is set to a level to provide a stable communication link.
op. 3	EGPRS 850 TCH Mode PCL=5 (max. power) TCH=128/192/251	A communication link is established between the mobile station and the test simulator. The transmitter is operated at its maximum rated output power: 33 dBm (power class 1; power control level 5). USF_Duty CYCLE set to 100%, coding scheme MCS-5 for 8-PSK modulation, slot 3 active, uplink gamma: 0 (33dBm). The input signal to the receiver is modulated with normal test modulation. The wanted RF input signal level to the receiver of the mobile station is set to a level to provide a stable communication link
op. 4	GSM 1900 Idle mode BCCH 651	The mobile station is synchronized to the Broadcast Control Channel (BCCH) and listening to the Common Control Channel (CCCH).
op. 5	GSM 1900 TCH mode TCH=512/661/810	A communication link is established between the mobile station and the test simulator. The transmitter is operated at its maximum rated output power: 30 dBm (power class 1; power control level 0). The input signal to the receiver is modulated with normal test modulation. The wanted RF input signal level to the receiver of the mobile station is set to a level to provide a stable communication link
op. 6	EGPRS 1900 TCH Mode PCL=0 (max. power) TCH=512/661/810	A communication link is established between the mobile station and the test simulator. The transmitter is operated at its maximum rated output power: 30 dBm (power class 1; power control level 0). USF_Duty CYCLE set to 100%, coding scheme MCS-5 for 8-PSK modulation, slot 3 active, uplink gamma: 3 (30dBm). The input signal to the receiver is modulated with normal test modulation. The wanted RF input signal level to the receiver of the mobile station is set to a level to provide a stable communication link
op. 7	Charging battery	Charging standard battery. This operating mode is combined with other op. modes.

*) EUT operating mode no. is used to simplify the test report.

3.6. Parameter Settings on mobile phone and base station CMU200

Following settings apply to the MS during the measurements in **GSM/(E)GPRS-Mode** only:

Parameter	Traffic Mode	Idle Mode
Traffic Channels mobile station (EUT)	GSM 850 TCH _{MS} = 128/ 192 /251 GSM 1900 TCH _{MS} = 512 / 681 / 810	--
maximum power level (PCL)	GSM 850: PCL = 5 (2 Watt) GSM 1900: PCL = 0 (1 Watt)	--
Modulation	GSM: GMSK-Modulation Scheme EDGE: 8-PSK Modulation Scheme	--
DTX	off	--
Bitstream	PRBS 2E9-1 (pseudo-random-sequence) – CCITT 0.153	
Timeslot	3	
Hopping	off	
Timeslot (slot mode)	GSM-Mode: single GPRS-Mode: maximum allowed uplink slots no. according MS class	
MS slot class	Class 10	
Maximum data transmission rate, single time slot	GSM: 17,6 kBit/s Slot EDGE: 59,2 kBit/s Slot	
Speech transcoding (Traffic Mode)	Full rate Version 1	
Mode	BCCH and TCH	
BCCH – base station (CMU,CMD)		GSM 850: 180 GSM 1900: 651
TCH – base station (CMD, CMU)	auto	
Power level TCH – base station (used timeslot level)	- 70 dBm	
Power level BCCH – base station (control channel level)	- 80 dBm	
External attenuation RF/AF-Input/Output	Accord. calibration prior to measurements	
Mobile Country Code	310	310
BS_AG_BLKS_RES	Not applicable	0
Paging reorganisation		Off (0)
Signalling channel		SDCCH
Location Update		Auto
Cell access		Disabled (barred)

Settings for CMU (general)

Repetition	Continuous	
Stop condition	None	
Display mode	Max./Min	
Statistic Count	1000 Bursts	
Decoder	Standard	

Additional settings on the base stations CMU200 for frequency stability measurements

4. DESCRIPTION OF TEST SET-UP's

4.1. Mode Test Set-up for conducted measurements

The EUT's RF-signal is coupled out by a suitable antenna coupling connector (1). The signal is first 10 dB attenuated (2) before it is 0° divided by a power divider (3). One of the signal path is connected to the communication base station (4), other branch is connected to the spectrum – analyzer (5). The specific attenuation losses for both signal paths/branches are determined prior to the measurement within a set-up calibration. These are then taken into account by correcting the measurement readings on the spectrum-analyzer.

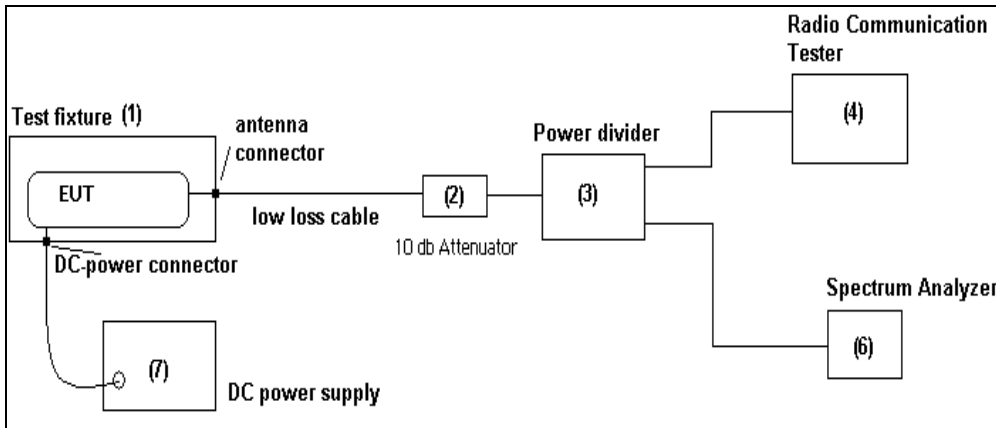

Schematic: Test set-up conducted

Following modified test set-up schematic apply for tests performed inside the climatic chamber: (Frequency stability)

In case an external connector is available (test fixture), following set-up is used for measurements.

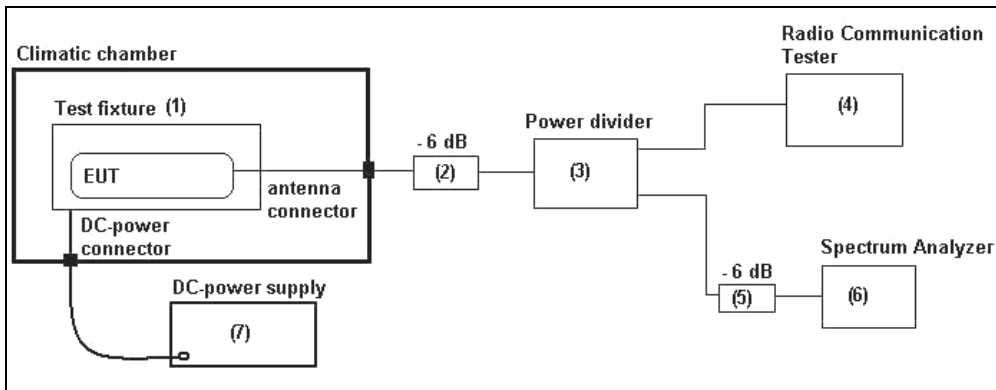

Schematic: Test set-up conducted within climatic chamber

4.2. Test set-up for radiated measurements

Pls. see above description and schematic for radiated measurements used set-up.

MEASUREMENT METHOD (1 GHz <math>f < 26.5 \text{ GHz}</math>):

The EUT and accessories are placed on a non-conducting tipping table of 0.8 meter height (semi-anechoic chamber) or 1.55m height (fully-anechoic chamber) which is situated in the middle of the turntable. The turntable can rotate the device under test 360 degree, the tipping table can rotate the device from laid to standing position. This way the device under test can be rotated in all three orthogonal planes in order to maximize the detected emissions. The turn- and tipping table are controlled by a controller unit. All positions manipulations are software controlled from a operator PC.

The measurements are performed for both receiving antenna polarisations: vertical and horizontal.

Up to 18 GHz a measurement distance of 3 meters is used, above 18 GHz the distance is 1 meter. A biconical-logarithmic antenna up to 1 GHz and a logarithmic-periodic antenna for frequencies above 1 GHz up to 26.5 GHz is used. For frequencies above 26.5 GHz a horn antenna is used, pls. compare the equipment list for more details.

The EUT is powered either by a external DC-supply with nominal voltage or a AC/DC power supply as accessory. The communication signalling (if necessary for operation) is performed from outside the chamber with a communication test simulator (CMU200 from Rohde&Schwarz) and a signalling antenna place near the EUT.

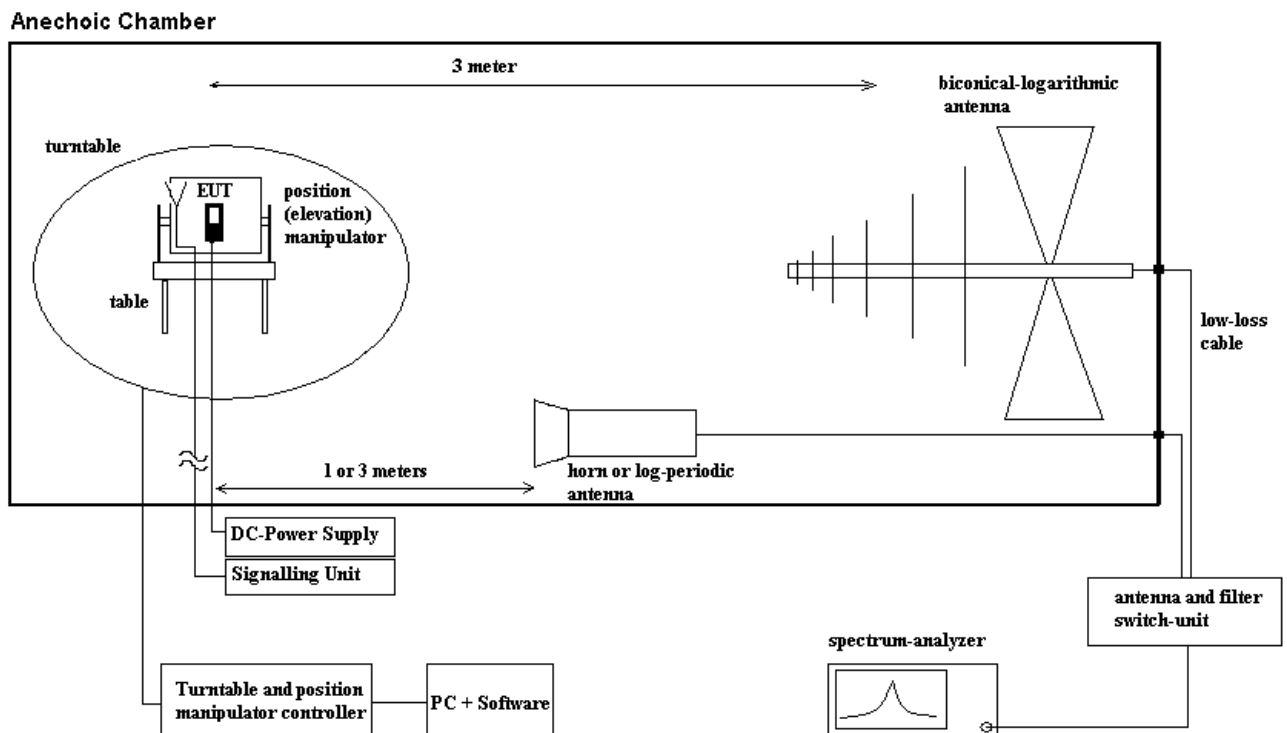

Schematic: radiated measurements test set-up

5. Measurements

5.1. RF power output (Conducted and Radiated)

REFERENCES

FCC: §2.1046 (conducted), §22.913(a)(2), § 24.232(c)

IC: RSS-132:4.4 + SRSP 503:5.1.3 for GSM 850; RSS-133:4.1/6.4 + SRSP-510:5.1.2 for GSM 1900

- Maximum Power Output of the mobile phone should be determined while measured conducted and radiated way.
- Regulatory Limit for GSM850 mobile equipment: 7 Watt
- Regulatory Limit for GSM1900 mobile equipment: 2 Watt

TEST SET-UP (CONDUCTED)

- see conducted measurement set-up, description in chapter 4.1.
- a suitable artificial antenna or RF-connector is provided by the applicant in order to perform the conducted measurements. Any data provided with the artificial antenna or connector, have been taken in account in order to correct the measurement data.

MOBILE PHONE SETTINGS

- according 3.6

BASE STATION SETTING

- according 3.6

5.1.1. Radiated RF-Power

TEST METHOD

1. The measurements were made at the upper, middle and lower carrier traffic frequencies of the operating band. Choosing three TX-carrier frequencies of the mobile phone within each operable GSM band, should be sufficient to demonstrate compliance.
2. The measurements were performed with the integrated power measurement function of the „radio communication tester *CMU* from *Rohde&Schwarz* company. In this way spectrum-analyzers instrument limitations can be avoided or minimized. Instead, *CMU* manufacturers declared measurement error can be considered for this measurement.
3. The attenuation (insertion loss) at the RF Inputs/Outputs of *CMU* were set according the path loss of the test set-up, determined in a step before starting the measurements.
4. PK and Average Values have been recorded for each channel and band.

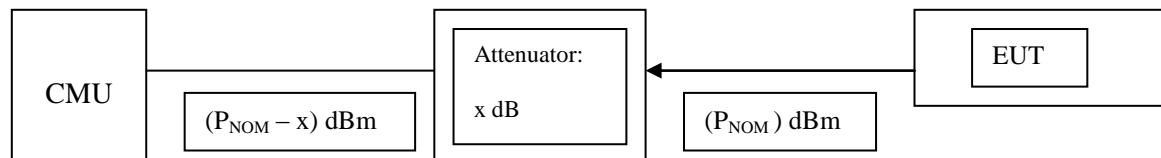

RESULTS (CONDUCTED)

Op. Mode 2, Set-up 2

Channel/ Frequency (MHz)		Peak Output Power (dBm)	Average Output Power (dBm)
GSM 850	Channel 128/ 824.2 MHz	34.08	33.08
	Channel 192/ 837 MHz	34.15	33.12
	Channel 251/ 848.8 MHz	34.09	33.13

Op. Mode 3, Set-up 2

Channel/ Frequency (MHz)		Peak Output Power (dBm)	Average Output Power (dBm)
E-GPRS 850	Channel 128/ 824.2 MHz	26.66	23.50
	Channel 192/ 837 MHz	26.75	23.52
	Channel 251/ 848.8 MHz	26.72	23.57

Op. Mode 5, Set-up 2

Channel/ Frequency (MHz)		Peak Output Power (dBm)	Average Output Power (dBm)
GSM 1900	Channel 512/ 1850.2 MHz	30.85	29.85
	Channel 661/ 1880.0 MHz	30.64	29.69
	Channel 810/ 1909.8 MHz	30.70	29.64

Op. Mode 6 Set-up 2

Channel/ Frequency (MHz)		Peak Output Power (dBm)	Average Output Power (dBm)
E-GPRS 1900	Channel 512/ 1850.2 MHz	27.78	24.56
	Channel 661/ 1880.0 MHz	27.56	24.27
	Channel 810/ 1909.8 MHz	27.45	24.17

VERDICT: passed

AMBIENT ENVIRONMENTAL CONDITIONS

Temperature	22.7 °C
Relative Humidity	50 %
Air pressure	1002 hPa

TEST EQUIPMENT

Used equipment (see reference in the annex)
OTA1: CMU200 Ref. No. 436, Atten. 6dB Ref.no 248, cable OTA20

5.1.2. Radiated RF-Power

TEST METHOD

The measurements were made at the upper, center, and lower carrier traffic frequencies of each of the supported operating band. Choosing three TX-carrier frequencies of the mobile phone, should be sufficient to demonstrate compliance.

The measurements were performed by using the **substitution method** (ANSI/TIA/EIA 603) with a spectrum-analyzer. This method can be described like follows:

- 1.) choosing of suitable spectrum-analyzer settings for performing the measurements. This settings of the spectrum analyzer must be maintained for both stages of the measurements: EUT emission measurements and also for measurements of the substituted level.

Parameter	Setting for GSM measurements	Settings for UTRA/FDD measurements
RBW _{3dB}	3 MHz	10 MHz
VBW	10 MHz	10 MHz
Span	20 MHz	50 MHz
Detector Mode	Positive max-hold	Positive max-hold
Average	off	off
Sweep Time	coupled	coupled

- 2.) The maximum level of the peak power was recorded, while the emissions were maximized by rotating the EUT in three orthogonal axes, which was situated on a non-conductive turntable of 1.55 m height ($P_{MEAS,1}$). This was performed for both measuring antenna polarisations (vertical/horizontal), the maximum of both values is used for further measurements and final substitution ($P_{MEAS,1,MAX}$).
- 3.) As the maximum emission is recorded, the EUT is replaced by a frequency dependant suitable antenna, which is connected to a RF-signal generator, which is transmitting on the determined worst-case frequency as determined in step 2.
- 4.) The RF-signal level of the signal generator is adjusted as long the same worst-case level determined first step is measured at the spectrum analyzer ($P_{SMHU}=P_{MEAS,1,MAX}$)
- 5.) Than the RF-signal cable is disconnected from the antenna and connected to a power-level meter. The level is determined ($P_{MEAS,2}$).
- 6.) The final result is calculated by adding the ERP/EIRP gain of the antenna which substitutes the EUT.
 $P_{EUT,SUBST} = P_{MEAS,2} + G_{ANTENNA}$

GSM RESULTS (RADIATED)

Channel/ Frequency (MHz)		Peak Output Power (dBm)			Antenna Polarisation	Verdict
		PK	AV			
GSM 850	Channel 128/ 824.2 MHz	25.40	1.)	ERP-Value	V/H	Passed
	Channel 192/ 837.0 MHz	28.92				
	Channel 251/ 848.8 MHz	30.62				
E-GPRS 850	Channel 128/ 824.2 MHz	20.57	1.)	ERP-Value	V/H	Passed
	Channel 192/ 837.0 MHz	22.77				
	Channel 251/ 848.8 MHz	23.75				

Remark: 1.) see conducted measurements for PAR factor

Channel/ Frequency (MHz)		Peak Output Power (dBm)		Antenna Polarisation	Verdict	
		PK	AV			
GSM 1900	Channel 512/ 1850.2 MHz	32.63	1.)	EIRP- Value	V/H	Passed
	Channel 661/ 1880.0 MHz	31.48				
	Channel 810/ 1909.8 MHz	31.12				
E-GPRS 1900	Channel 512/ 1850.2 MHz	28.40	1.)	EIRP- Value	V/H	Passed
	Channel 661/ 1880.0 MHz	26.84				
	Channel 810/ 1909.8 MHz	26.87				

Remark: 1.) see conducted measurements for PAR factor

AMBIENT ENVIRONMENTAL CONDITIONS

Temperature	25.4 °C
Relative Humidity	67 %
Air pressure	1000 hPa

TEST EQUIPMENT

Used equipment (see reference in the annex)
Antenna 1GHz : #608
Antenna 18GHz : #549
FAR Chamber : #443
FSEK : #264
CMU200 : #546

5.2. Occupied and emission bandwidth

REFERENCES

FCC: §2.202, §2.1049, §22.917(a), §24.238(a)
 IC: RSS-Gen: 4.6.1

„the **occupied bandwidth** is the frequency bandwidth, such that, below it lower and above it upper frequency limits, the mean powers radiated are each equal to 0.5 percent of the total mean power radiated”

TEST SET-UP

- see conducted measurement set-up described in 4.1

MOBILE PHONE SETTINGS

- Provisions with the requirements is based on the fact, that GSM modulation scheme is GMSK Modulation for GSM equipment with a maximum data transmission rate of 17,6 kBit/s per Slot.
- Provisions with the requirements is based on the fact, that EDGE modulation scheme is 8-PSK Modulation for EDGE equipment with a maximum data transmission rate of 69,2 kBit/s per Slot.
- according chapter 3.7 a call was established

SETTINGS OF THE SPECTRUM-ANALYSER

Frequency range	RBW (resolution bandwidth)	VBW (video bandwidth)
<i>1 MHz around carrier frequency</i>	<i>1% from applicants stated/measured emission bandwidth</i>	<i>3..10 times the RBW</i>

TEST METHOD

The measurements were made at the upper, middle and lower carrier traffic frequencies of the operating band. Choosing three TX-carrier frequencies of the mobile phone within each operable GSM band, should be sufficient to demonstrate compliance

Additionally the emission bandwidth (-26 dBc bandwidth) was recorded for all three channels. The results were taken in order to determine according the §24.238 the measurement resolution bandwidth, which should be approximately 1% of the emission bandwidth.

RESULTS

Set-up 2, Op-Mode 2

Channel/ Frequency (MHz)		Occupied 99% bandwidth [kHz]	Emission bandwidth [kHz]
GSM 850	Channel 128/ 824.2 MHz	245.1923	310.8974
	Channel 192/ 837 MHz	246.7948	314.1025
	Channel 251/ 848.8 MHz	245.1923	312.5000

Remarks: see annex A1 for diagrams

Set-up 2, Op-Mode 3

Channel/ Frequency (MHz)		Occupied 99% bandwidth [kHz]	Emission bandwidth [kHz]
EGPRS 850	Channel 128/ 824.2 MHz	238.7820	312.5000
	Channel 192/ 837 MHz	245.1923	304.4871
	Channel 251/ 848.8 MHz	248.3974	317.3076

Remarks: see annex A1 for diagrams

Set-up 2, Op-Mode 5

Channel/ Frequency (MHz)		Occupied 99% bandwidth [kHz]	Emission bandwidth [kHz]
GSM 1900	Channel 512/ 1850.2 MHz	243.5897	317.3076
	Channel 661/ 1880.0 MHz	243.5897	314.1025
	Channel 810/ 1909.8 MHz	243.5897	314.1025

Remarks: see annex A1 for diagrams

Set-up 2, Op-Mode 6

Channel/ Frequency (MHz)		Occupied 99% bandwidth [kHz]	Emission bandwidth [kHz]
EGPRS 1900	Channel 512/ 1850.2 MHz	246.7948	306.0897
	Channel 661/ 1880.0 MHz	243.5897	306.0897
	Channel 810/ 1909.8 MHz	243.5897	312.5000

Remarks: see annex A1 for diagrams

AMBIENT ENVIRONMENTAL CONDITIONS

Temperature	25.4 °C
Relative Humidity	67 %
Air pressure	1000 hPa

TEST EQUIPMENT

Used equipment (see reference in the annex)
CMU200 #547
ESU #489
Power source #463
6dB Power divider #529
10dB attenuator #530

5.3. Emission limits (Spurious emission conducted and radiated)

REFERENCES

FCC: §2.1051-conducted, §2.1053(a)-radiated, §2.1057, §22.917(a)(b); §24.238(a)(b)
 IC: RSS-132: 4.5.1&4.5.2, RSS-133: 6.5.1(a)(b)

„the power of emissions shall be attenuated below the transmitter output power (p) by at least least $43+10\text{Log}(P)$ dB“

FREQUENCY RANGE

The spectrum was scanned from 30 MHz to the 10th harmonic of the highest frequency generated within the equipment. The detector used was Peak.

The specification that all emissions shall be attenuated below the transmitter power (P) by at least $43 + 10 \log (P)$ dB, translates in the relevant power range of the mobile phone (1 to 0.001 W) to a constant limit of -13 dBm.

DESCRIPTION OF SET-UP

- see conducted set-up in chapter 4.1
- see radiated set-up in chapter 4.2

SETTINGS ON MOBILE PHONE

The measurements were made at the upper, middle, and lower carrier frequencies of the operating band. Choosing three representative TX-carrier frequencies of the mobile phone within each operable GSM band, should be sufficient to demonstrate compliance with the emissions limits outside and adjacent to the frequency blocks.

The individual settings were made according chapter 3.6

TEST METHOD RADIATED:

By rotating the EUT in three orthogonal planes, the emissions were recorded with Peak-Detector and Hold-Max function of the spectrum-analyzer. If the harmonic could not be detected above the noise floor, the ambient level was recorded. Measurement distance is 3m for frequencies up to 18GHz and 1m for frequencies greater then 18GHz. The readings on the spectrum analyzer are corrected with annually performed chamber path calibration values so the readings shown are equivalent to ERP/EIRP values. Critical measurements near the limit are re-measured with a substitution method accord. ANSI/TIA/EIA 603.

SETTINGS OF SPECTRUM-ANALYSER

Frequency range	RBW (resolution bandwidth)	VBW (video bandwidth)
BAND-EDGE compliance: 1MHz immediately adjacent to the frequency blocks	1% from applicants stated/measured emission bandwidth	3..10 times the RBW
More than 1 MHz outside and adjacent the frequency blocks	1kHz or 100kHz to measurement frequencies up to 1MHz 1 MHz for measurement frequency range 1MHz to maximum 10-times TX-frequency	3..10 times the RBW

DATA RESULTS (CONDUCTED)

5.3.0.1. GSM TCH 850: Op. Mode 2, Set-up 2

Lowest channel: 128

Transmitting channel/ frequency: TX = 824.2 MHz							
Sweep frequency range: [MHz]	Diagram number	Frequency of emission [MHz]	Worst-Level Polarisation	Transducer factor [dB]	Result [dBm]	Limit [dBm]	Verdict
Sweep 1	14.01	1.51	--	--	-50.25	-13	Passed
Sweep 2	14.02	207.90 1648.6	--	--	-38.34 -36.20		Passed
Sweep 3 ^{1.)}	14.03	823.99	--	--	-26.24		Passed

Remark: see diagrams for more details

1.) Band-Edge compliance

Middle channel = 192

Transmitting channel/ frequency: TX = 837 MHz							
Sweep frequency range: [MHz]	Diagram number	Frequency of emission [MHz]	Worst-Level Polarisation	Transducer factor [dB]	Result [dBm]	Limit [dBm]	Verdict
Sweep 1	14.04	0.068	--	--	-61.04	-13	Passed
Sweep 2	14.05	196.21 1673.86	--	--	-38.34 -34.83		Passed

Remark: see diagrams for more details

Highest channel: 251

Transmitting channel/ frequency: TX = 848.8 MHz							
Sweep frequency range: [MHz]	Diagram number	Frequency of emission [MHz]	Worst-Level Polarisation	Transducer factor [dB]	Result [dBm]	Limit [dBm]	Verdict
Sweep 1	14.06	0.0169	--	--	-55.96	-13	Passed
Sweep 2	14.07	55.59 1696.77 12294	--	--	-39.03 -35.29 -29.84		Passed
Sweep 3 ^{1.)}	14.08	849.02	--	--	-24.17		Passed

Remark: see diagrams for more details

1.) Band-Edge compliance

5.3.0.2. GSM 1900 Mode: Op. Mode 5, Set-up2

Lowest channel: 512

Transmitting channel/ frequency: TX = 1850,2 MHz							
Sweep frequency range: [MHz]	Diagram number (H/V)	Frequency of emission [MHz]	Worst-Level Polarisation	Transducer factor [dB]	Result [dBm]	Limit [dBm]	Verdict
Sweep 1	14.09	0.068	--	--	-62.18	-13	Passed
Sweep 2	14.10	12258.85	--	--	-29.43		Passed
Sweep 3	14.11	1849.97	--	--	-29.58		Passed ^{4.)}

Remark: see diagrams for more details

4.) Band-Edge compliance

Middle channel: 661

Transmitting channel/ frequency: TX = 1880,0 MHz							
Sweep frequency range: [MHz]	Diagram number (H/V)	Frequency of emission [MHz]	Worst-Level Polarisation	Transducer factor [dB]	Result [dBm]	Limit [dBm]	Verdict
Sweep 1	14.12	7.559	--	--	-52.46	-13	Passed
Sweep 2	14.13	12237.6	--	--	-30.35		Passed

Remark: see diagrams for more details

Highest channel: 810

Transmitting channel/ frequency: TX = 1908,8 MHz							
Sweep frequency range: [MHz]	Diagram number (H/V)	Frequency of emission [MHz]	Worst-Level Polarisation	Transducer factor [dB]	Result [dBm]	Limit [dBm]	Verdict
Sweep 1	14.14	7.599	--	--	-56.14	-13	Passed
Sweep 2	14.15	11770.1	--	--	-29.39		Passed
Sweep 3	14.16	1910.01	--	--	-28.03		Passed ^{4.)}

Remark: see diagrams for more details

4.) Band-Edge compliance

AMBIENT ENVIRONMENTAL CONDITIONS

Temperature	25.4 °C
Relative Humidity	67 %
Air pressure	1000 hPa

TEST EQUIPMENT

Used equipment (see reference in the annex)
CMU200 #547
Power source #463
6dB power-divider #529
10dB attenuator #530
ESU#489

RESULTS (RADIATED)

5.3.0.2.1. GMSK 850 Mode: Op. Mode 2, Set-up 1

Lowest channel: 128

Transmitting channel/ frequency: TX = 824.2 MHz							
Sweep frequency range: [MHz]	Diagram number (H/V)	Frequency of emission [MHz]	Worst-Level Polarisation	Transducer factor [dB]	Result [dBm]	Limit [dBm]	Verdict
Sweep 1 ^{2.)}	8.01	30..1000	H	--	< -28.0	-13	Passed ^{2.)}
	8.02	30..1000	V	--	< -28.0		
Sweep 2 ^{4.)}	8.03	823.96	H	--	-29.97		Passed ^{4.)}
	8.04	823.98	V	--	-25.65		
Sweep 4	8.05	2713.4	H	--	-21.52		Passed
	8.06	2428.5	V	--	-22.17		
Sweep 5	8.17	2800..12000	H	--	<-29.0	Passed	
	8.18	2800..12000	V	--	< 29.76	Passed	

Remarks: see diagrams enclosed in annex A1

- 1.) only results near 20dB to the limit are referenced or noise level
- 2.) TX-carrier on the diagram
- 4.) Band-Edge compliance

Middle channel: 192

Transmitting channel/ frequency: TX = 837 MHz							
Sweep frequency range: [MHz]	Diagram number (H/V)	Frequency of emission [MHz]	Worst-Level Polarisation	Transducer factor [dB]	Result [dBm]	Limit [dBm]	Verdict
Sweep 1 ^{2.)}	8.15	30..1000	H	--	< -28.0	-13	Passed ^{2.)}
	8.16	30..1000	V	--	< -28.0		
Sweep 4	8.19	1000..2800	H	--	<-21.76		Passed
	8.20	2634.1	V	--	<-21.19		
Sweep 5	8.21	11207	H	--	-30.13		Passed
	8.20	2800..12000	V	--	-29.57		Passed

Remarks: see diagrams enclosed in annex A1

- 1.) only results near 20dB to the limit are referenced or noise level
- 2.) TX-carrier on the diagram

Highest channel: 251

Transmitting channel/ frequency: TX = 849.8 MHz							
Sweep frequency range: [MHz]	Diagram number (H/V)	Frequency of emission [MHz]	Worst-Level Polarisation	Transducer factor [dB]	Result [dBm]	Limit [dBm]	Verdict
Sweep 1 ^{2.)}	8.15	30..1000	H	--	<-28.0	-13	Passed ^{2.)}
	8.06	30..1000	V	--	<-28.0		Passed ^{4.)}
Sweep 3 ^{4.)}	8.17	849.02	H	--	-24.12		Passed
	8.18		V	--			Passed
Sweep 4	8.19	2608.8	H	--	-21.76		Passed
	8.20	2634.1	V	--	-21.19		Passed
Sweep 5	8.21	11207	H	--	30.13	Passed	
	8.22	11797	V	--	-29.57	Passed	

Remarks: see diagrams enclosed in annex A1

- 1.) only results near 20dB to the limit are referenced or noise level
- 2.) TX-carrier on the diagram
- 4.) Band-Edge compliance

5.3.0.3. GSM 1900 Mode: Op. Mode 5, Set-up 2

Lowest channel: 512

Transmitting channel/ frequency: TX = 1850,2 MHz							
Sweep frequency range: [MHz]	Diagram number (H/V)	Frequency of emission [MHz]	Worst-Level Polarisation	Transducer factor [dB]	Result [dBm]	Limit [dBm]	Verdict
Sweep 1	8.23	823.04	H	--	<-31.55	-13	Passed
	8.24	970.81	V	--	<-30.27		Passed ^{2.)}
Sweep 2	8.25	1851.3	H	--	<-20.0		Passed ^{4.)}
	8.26	1000-2800	V	--	<-20.0		Passed
Sweep 3	8.27	1850.0	H	--	-17.52		Passed
	8.28	1850.0	V	--	-18.52		Passed
Sweep 5	8.29	11723.0	H	--	<-29.27		Passed
	8.30	11760	V	--	<-29.39		Passed
Sweep 6	8.31	16052	H	--	<-23.90	Passed	
	8.32	17074	V	--	<-23.22	Passed	
Sweep 7 ^{3.)}	--	18..20GHz		--	<-27.55	Passed ^{3.)}	

Remark: see diagrams for more details, only worst-case polarisation mentioned

- 2.) Peaks from Set-up, TCH channel of mobile phone
- 3.) overview measurement only
- 4.) Band-Edge compliance

Middle channel: 661

Transmitting channel/ frequency: TX = 1880,0 MHz							
Sweep frequency range: [MHz]	Diagram number (H/V)	Frequency of emission [MHz]	Worst-Level Polarisation	Transducer factor [dB]	Result [dBm]	Limit [dBm]	Verdict
Sweep 1	8.35	30..1000	H	--	<-30.10	-13	Passed
	8.36	30..1000	V	--	<-30.43		Passed ^{2.)}
Sweep 2	8.37	1000..2800	H	--	<-26.75		Passed
	8.38	1000..2800	V	--	<-20.0		Passed
Sweep 5	8.39	2800..12000	H	--	<-28.79		Passed
	8.40	2800..12000	V	--	<-29.67		Passed
Sweep 6	8.41	17314	H	--	-23.60		Passed
	8.42	17519	V	--	-23.10	Passed	
Sweep 7 ^{3.)}	--	18..20GHz		--	<-27.26	Passed ^{3.)}	

Remark: see diagrams for more details, only worst-case polarisation mentioned

2.) Peaks from Set-up, TCH channel of mobile phone

3.) overview measurement only

Highest channel: 810

Transmitting channel/ frequency: TX = 1908,8 MHz							
Sweep frequency range: [MHz]	Diagram number (H/V)	Frequency of emission [MHz]	Worst-Level Polarisation	Transducer factor [dB]	Result [dBm]	Limit [dBm]	Verdict
Sweep 1	8.45	30..1000	H	--	<-30.58	-13	Passed
	8.46		V		<-29.70		
Sweep 2	8.47	1000..2800	H	--	<-20.0		Passed ^{2.)}
	8.48		V		<-20.0		
Sweep 4 ^{4.)}	8.49	1910.0	H	--	-15.54		Passed ^{4.)}
	8.50		V		-15.84		
Sweep 5	8.51	11779	H	--	<-29.64		Passed
	8.52		V		<-29.53		
Sweep 6	8.53	15776	H	--	-22.55	Passed	
	8.54	16978	V		-23.30		
Sweep 7 ^{3.)}	--	18..20GHz		--	<-27.42	Passed ^{3.)}	

Remark: see diagrams for more details, only worst-case polarisation mentioned

- 2.) Peaks from Set-up, TCH channel of mobile phone
- 3.) overview measurement only
- 4.) Band-Edge compliance

AMBIENT ENVIRONMENTAL CONDITIONS

Temperature	26.9 °C
Relative Humidity	52 %
Air pressure	996 hPa

TEST EQUIPMENT

Used equipment (see reference in the annex)
Signalling : CMU200 #546
Antenna 1GHz : #608
Antenna 18GHz : #549
FAR : #443
Horn Antenna 40GHz : #302
FSEK #264, ESU #489
Switch Unit FAR, FAR-A.#443

5.4. Radiated field strength emissions below 30 MHz

TEST LOCATION AND EQUIPMENT (for reference numbers please see chapter 'List of test equipment')

test location	<input checked="" type="checkbox"/> CETECOM Essen (Chapter. 2.2.1)	<input type="checkbox"/> Please see Chapter. 2.2.2	<input type="checkbox"/> Please see Chapter. 2.2.3
test site	<input checked="" type="checkbox"/> 441 EMI SAR	<input type="checkbox"/> 487 SAR NSA	<input type="checkbox"/> 337 OATS
receiver	<input type="checkbox"/> 377 ESCS30	<input checked="" type="checkbox"/> 001 ESS	<input type="checkbox"/> 347 Radio.lab.
spectr. analys.	<input type="checkbox"/> 381 380 FSBS	<input type="checkbox"/> 120 FSEM	<input type="checkbox"/> 264 FSEK
antenna	<input type="checkbox"/> 048 EMCO3143	<input type="checkbox"/> 133 EMCO3115	<input type="checkbox"/> 302 BBHA9170
signaling	<input type="checkbox"/> 298 CMU	<input type="checkbox"/> 460 CMU	<input type="checkbox"/> 289 CBL 6141
power supply	<input type="checkbox"/> 456 EA 3013A	<input type="checkbox"/> 457 EA 3013A	<input type="checkbox"/> 295 RACAL
otherwise	<input type="checkbox"/> 400 FTC40x15E	<input type="checkbox"/> 401 FTC40x15E	<input type="checkbox"/> 110 USB LWL
			<input type="checkbox"/> 268 EA- 3050
			<input type="checkbox"/> 494 AG6632A
			<input type="checkbox"/> 498 NGPE 40
			<input type="checkbox"/> 482 Filter Matrix

STANDARDS AND LIMITS: CFR 47, §15.205, §15.209, RSS-Gen, ANSI C63.10:2009

Frequency [MHz]	Field strength		Measurement distance [meters]	Remarks
	[µV/m]	[dBuV/m]		
0.009 – 0.490	2400/f (kHz)	67.6 – 20Log(f) (kHz)	300	Correction factor used due to measurement distance of 3m
0.490 – 1.705	24000/f (kHz)	87.6 – 20 Log(f) (kHz)	30	Correction factor used due to measurement distance of 3m
1.705 – 30	30	29.54	30	Correction factor used due to measurement distance of 3m

Remark: * decreases with the logarithm of the frequency

TEST CONDITION AND MEASUREMENT TEST SET-UP

link to test system (if used):	<input type="checkbox"/> air link	<input type="checkbox"/> cable connection	<input type="checkbox"/>
EUT-grounding	<input checked="" type="checkbox"/> none	<input type="checkbox"/> with power supply	<input type="checkbox"/> additional connection
Equipment set up	<input checked="" type="checkbox"/> table top		<input type="checkbox"/> floor standing
Climatic conditions	Temperature: (26°C)		Rel. humidity: (52)%
EMI-Receiver (Analyzer) Settings	Span/Range: 9kHz to 150kHz; 150 kHz to 30 MHz RBW/VBW: 200Hz/auto; 10 kHz/ auto (ANSI63.10/CISPR#16) Detector/ Mode: PEAK, TRACE max-hold mode, repetitive scan for exploratory measurements Quasi-Peak, for final measurement on critical frequencies (f<1GHz)		

GENERAL MEASUREMENT PROCEDURES:

The measurement test set-up and test procedure are in accordance with the provisions described in ANSI 63.10: 2009

The **Equipment under Test** (EUT) was set-up to defined operating mode and installed (connected) to accessory equipment according the general description of use given by the applicant.

The measurement loop antenna was situated in 3m distance to the EUT. Between EUT and measurement antenna absorbers are covering the GND-Plane. With these absorbers the chamber fulfills CIPR16-1-4 site VSWR-criteria. Radiated magnetic emission measurements were made with the antenna situated in 1 meter height. The loop antenna was moved at least to 2-perpendicular axes (antenna vector in direction of EUT and parallel to EUT) in order to maximize the emissions, the EUT itself either over 3-orthogonal axes (no defined usage position) or 2-orthogonal axis (defined usage position) by the position manipulator.

According the standard the compliance should be checked in 30m and 300m measurement distance. Therefore a additional extrapolation factor was used in order to normalize the measurement data. The frequency dependent extrapolation factor used for this reduced measurement distance, can be found in the chapter 7.

MEASUREMENT RESULTS

Set-up No.		1								
Operating Mode		2 + 7, Channel 128								
Diagram no.	Frequency	MaxPeak	Meas. Time	Bandwidth	Antenna height	Polarity	Turntable position	Corr. (dB)	Margin (dB)	Limit (dB μ V/m)
	(MHz)	(dB μ V/m)	(ms)	(kHz)	(cm)		(deg)	(C _F)	(M)	(L _T)
a_3.01	0.09 to 0.15	< -58.84 ^{1.)}	10.0	0.2	1.00	--	0°..360°	Chapt. 7	>20.0	29.54
	0.15 to 0.490	< -65.0	10.0	10.0		--			>20.0	
	0.490 to 30	< 16.29	10.0	10.0		--			> 13.25	

Remark: 1.) External interferer, not from EUT

Set-up No.		1								
Operating Mode		2 + 7, Channel 192								
Diagram no.	Frequency	MaxPeak	Meas. Time	Bandwidth	Antenna height	Polarity	Turntable position	Corr. (dB)	Margin (dB)	Limit (dB μ V/m)
	(MHz)	(dB μ V/m)	(ms)	(kHz)	(cm)		(deg)	(C _F)	(M)	(L _T)
a_3.02	0.09 to 0.15	< -61.08 ^{1.)}	10.0	0.2	1.00	--	0°..360°	Chapt. 7	>20.0	See diagram
	0.15 to 0.490	< -65.0	10.0	10.0		--			>20.0	
	0.490 to 30	< 15.13	10.0	10.0		--			> 14.41	29.54

Remark: 1.) External interferer, not from EUT

Set-up No.		1								
Operating Mode		2 + 7, Channel 551								
Diagram no.	Frequency	MaxPeak	Meas. Time	Bandwidth	Antenna height	Polarity	Turntable position	Corr. (dB)	Margin (dB)	Limit (dB μ V/m)
	(MHz)	(dB μ V/m)	(ms)	(kHz)	(cm)		(deg)	(C _F)	(M)	(L _T)
a_3.03	0.09 to 0.15	< 63.41 ^{1.)}	10.0	0.2	1.00	--	0°..360°	Chapt. 7	>20.0	See diagram
	0.15 to 0.490	< -65.0	10.0	10.0		--			>20.0	
	19.15	7.26 (QP)	1000	10.0		--	86	2.7	22.30	29.54
	0.490 to 30	< 6.86	10.0	10.0		--	0°..360°	Chapt. 7	> 22.70	29.54

Remark: 1.) External interferer, not from EUT

Remark: positive margin means passed result

<p>Abbreviations used:</p> <ul style="list-style-type: none"> • R_R : Receiver readings in dBμV/m • C_F: Transducer in dB = AF (antenna factor) + CL (cable loss) • D_F : distance correction factor (if different measurement distance used than specified in the standard) • L_T : Limit in dBμV/m

VERDICT: Summary of measurement results for radiated frequencies below 30 MHz - passed

5.5. Frequency stability on temperature and voltage variations

REFERENCES

FCC: §2.1055(a)(2), §22.355, §24.235

IC: RSS-132: 4.3, RSS-133: 6.3

§22.355 Table C-1; § 24.235

“The frequency stability shall be sufficient to ensure that the fundamental emission stays within the authorized frequency block”

TEST SET-UP

In order to maintain the voltage constant over the time period of the tests, a dummy battery was connected to a laboratory power supply. The power supply voltage was controlled on the input of the power supply terminals of the EUT.

Compare with the conducted measurement test set-up described in chapter 4.1

MOBILE PHONE SETTINGS

- The measurements were made at the upper, middle, and lower carrier frequencies of the operating band. Choosing three representative TX-carrier frequencies of the mobile phone within each operable GSM band, should be sufficient to demonstrate compliance.
- according chapter 3.7

TEST METHOD

The RF Channel spacing is 200kHz, with a guard band of 200kHz of each band of the sub-bands. The aim of the EUT is to function under all extreme conditions within authorized sub-bands in regard to temperature and voltage variations. The frequency deviation was recorded with base station's build in capability. (CMU)

As the standard requires that the fundamental emissions stays within the authorized band, a limit of 0.1ppm is considered low enough to ensure this.

Frequency shift of carrier against a voltage range at constant nominal temperature of 20° Celsius

- 1.) determine the carrier frequency for the lowest and highest channel at room temperature and nominal voltage [20°C]
- 2.) The voltage was reduced in 0.1V steps to the lower end point, where the mobile phone stops working. (this shall be specified by the manufacturer) Record the carrier frequency shift within 2 minutes after powering on the mobile phone, to prevent for self heating effects.
- 3.) The voltage was increased in 0.1V steps to the upper declared voltage of the battery. Record the carrier frequency shift within 2 minutes after powering on the mobile phone, to prevent for self heating effects.

RESULTS

5.5.0.1. GSM 850 Mode: Op. Mode 2, set-up 2

Channel 192

Voltage [V]	Nominal Frequency [Hz]	Maximum frequency error		Verdict
		[Hz]	[ppm]	
3,50		-23	-0,027	
3,60		-23	-0,027	
3,70		-40	-0,048	
3,80	8,37E+08	-22	-0,026	passed
3,90		-22	-0,026	
4,00		-20	-0,024	
4,10		-43	-0,051	

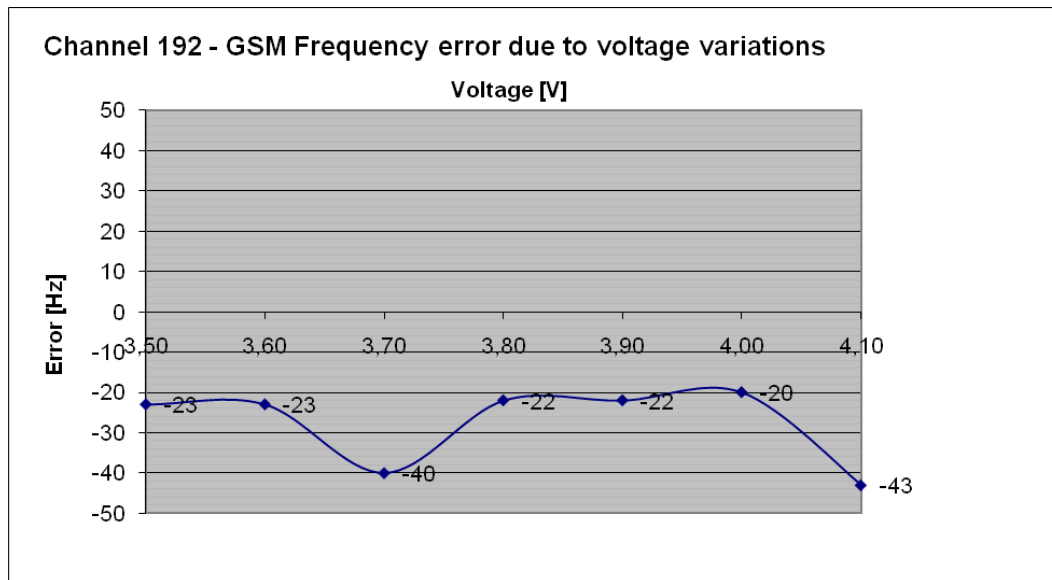

5.5.0.2. E-GPRS 850 Mode: Op. Mode 3, set-up 2

Voltage [V]	Nominal Frequency [Hz]	Maximum frequency error		Verdict
		[Hz]	[ppm]	
3,50	8,37E+08	33	0,039	passed
3,60		40	0,048	
3,70		32	0,038	
3,80		32	0,038	
3,90		26	0,031	
4,00		25	0,030	
4,10		20	0,024	

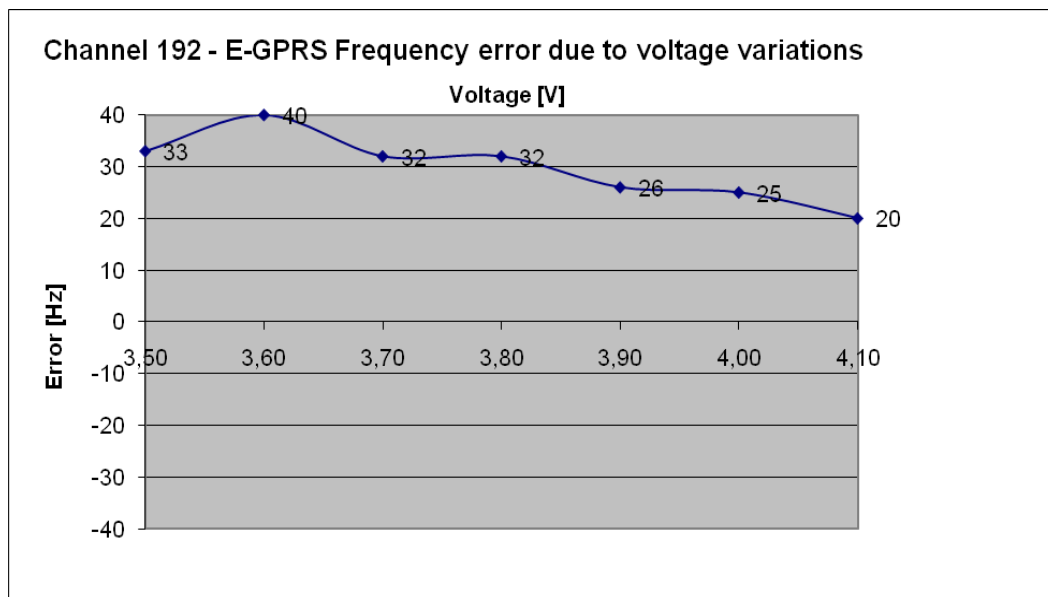

5.5.0.3. GSM 1900 Mode: Op. Mode 5, set-up 2

Channel 661

Voltage [V]	Nominal Frequency [Hz]	Maximum frequency error		Verdict
		[Hz]	[ppm]	
3,50	1,88E+09	20	0,011	passed
3,60		14	0,007	
3,70		17	0,009	
3,80		15	0,008	
3,90		15	0,008	
4,00		18	0,010	
4,10		16	0,009	

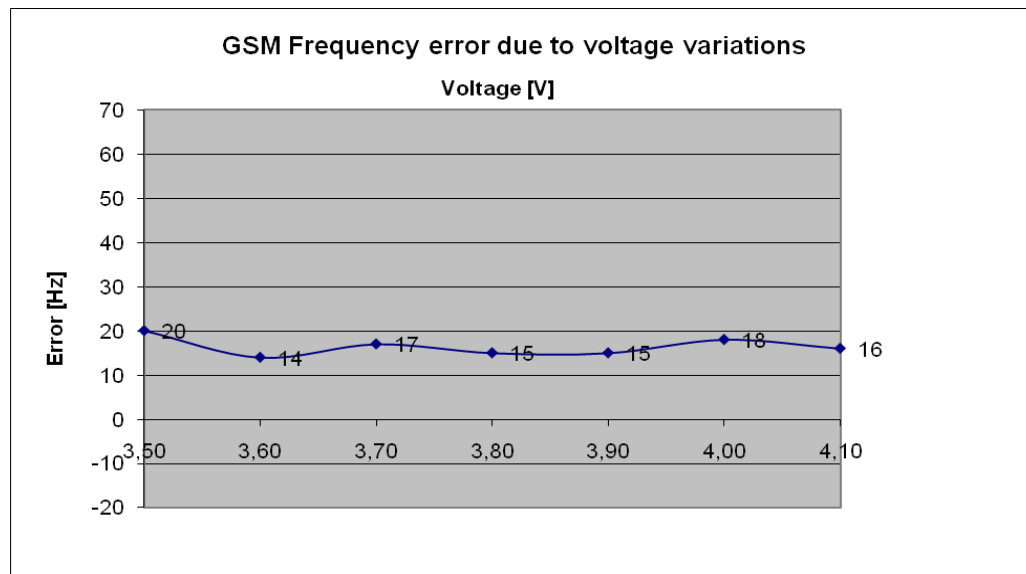

5.5.0.4. E-GPRS 1900 Mode: Op. Mode 6, set-up 3

Channel 661

Voltage [V]	Nominal Frequency [Hz]	Maximum frequency error		Verdict
		[Hz]	[ppm]	
3,50	1,88E+09	60	0,032	passed
3,60		58	0,031	
3,70		59	0,031	
3,80		52	0,028	
3,90		53	0,028	
4,00		53	0,028	
4,10		56	0,030	

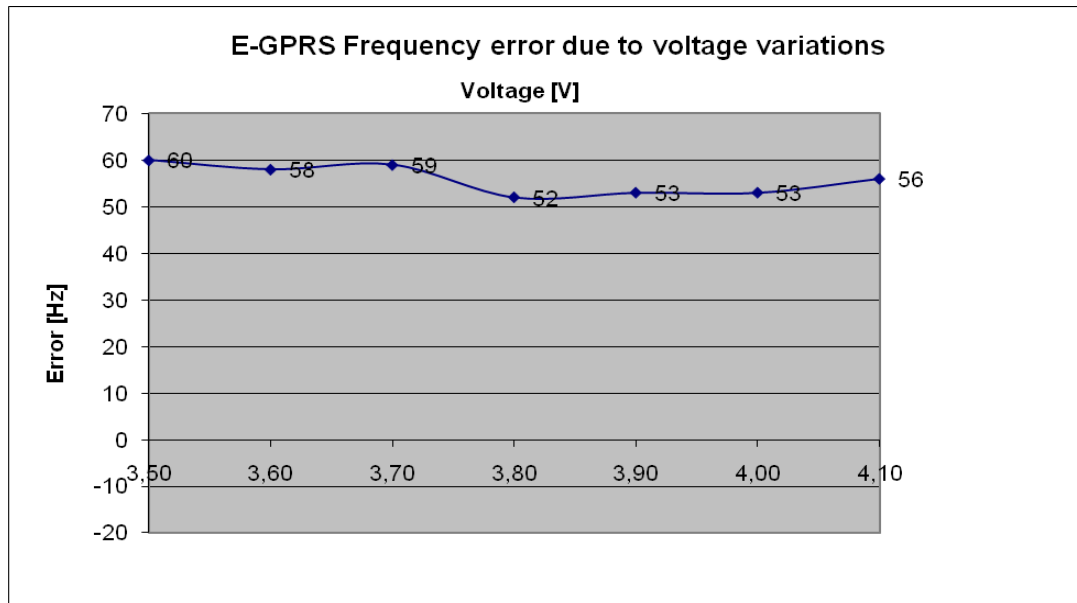

TEST EQUIPMENT

Used equipment (see reference in the annex)
CMU200 : #547
Climatic chamber : #331
POWER Supply : #354
Power attenuator : #530

Frequency shift of carrier against temperature at constant power supply voltage

- 1.) determine the carrier frequency for the lowest, middle and highest channel at room temperature and nominal voltage [20°C]
- 2.) expose the mobile station to -30°C, wait sufficient time to have constant temperature.
- 3.) Perform the carrier frequencies measurements in 10°C increments from -30°C to +60°C. For about half hour at the specified temperature the mobile was powered-off. After powering-on, the measurements were made within 2 minute for the channel lower channel, in order to prevent self-warming of the mobile.

RESULTS

5.5.0.5. GSM 850 Mode: Op. Mode 2, set-up 2

Temperature	Maximum frequency error						Verdict Limit=±0.1ppm
	Channel 128 [Hz]	Channel 192 [Hz]	Channel 251 [Hz]	Channel 128 [ppm]	Channel 192 [ppm]	Channel 251 [ppm]	
-30	28	-17	-38	0,034	-0,020	-0,045	Passed
-20	44	15	-45	0,053	0,018	-0,053	
-10	37	28	26	0,045	0,033	0,031	
0	45	22	23	0,055	0,026	0,027	
10	-49	-21	-47	-0,059	-0,025	-0,055	
20	-39	-40	-26	-0,047	-0,048	-0,031	
30	-40	-22	-23	-0,049	-0,026	-0,027	
40	-59	-57	-54	-0,072	-0,068	-0,064	
50	-52	-24	-33	-0,063	-0,029	-0,039	

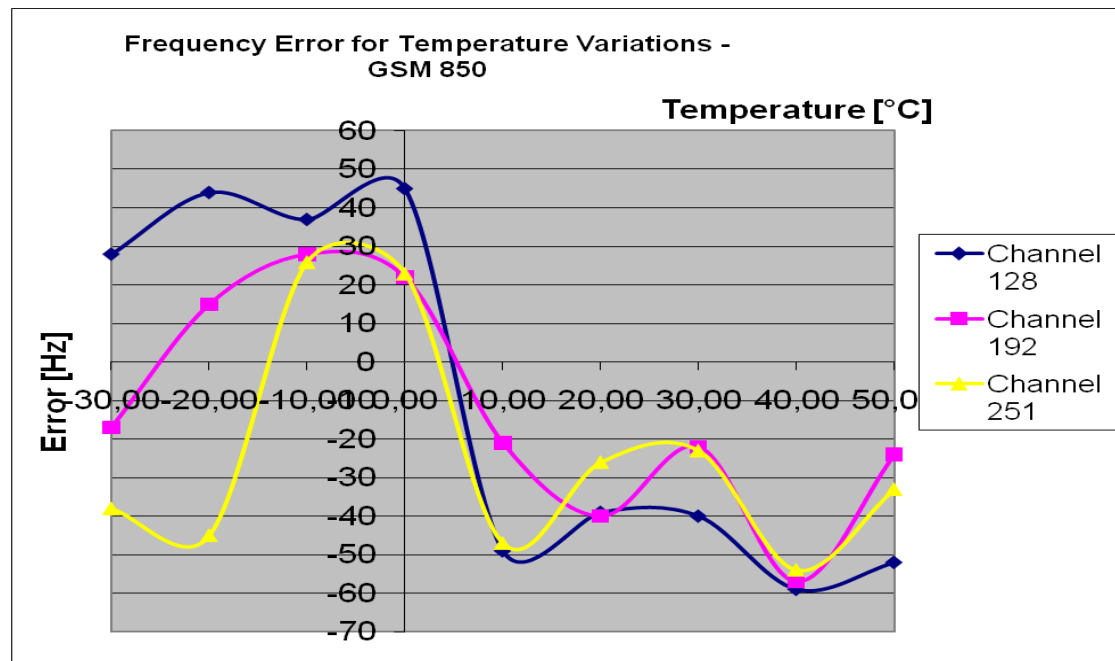

5.5.0.6. E-GPRS 850 Mode: Op. Mode 3, set-up 2

Temperature	Maximum frequency error						Verdict Limit=±0.1ppm
	Channel 128	Channel 192	Channel 251	Channel 128	Channel 192	Channel 251	
	[Hz]			[ppm]			
-30	56	58	53	0,068	0,069	0,062	Passed
-20	39	-23	-34	0,047	-0,027	-0,040	
-10	45	34	31	0,055	0,041	0,037	
0	37	61	33	0,045	0,073	0,039	
10	-23	39	-42	-0,028	0,047	-0,049	
20	33	32	30	0,040	0,038	0,035	
30	27	29	29	0,033	0,035	0,034	
40	-37	38	-39	-0,045	0,045	-0,046	
50	26	28	29	0,032	0,033	0,034	

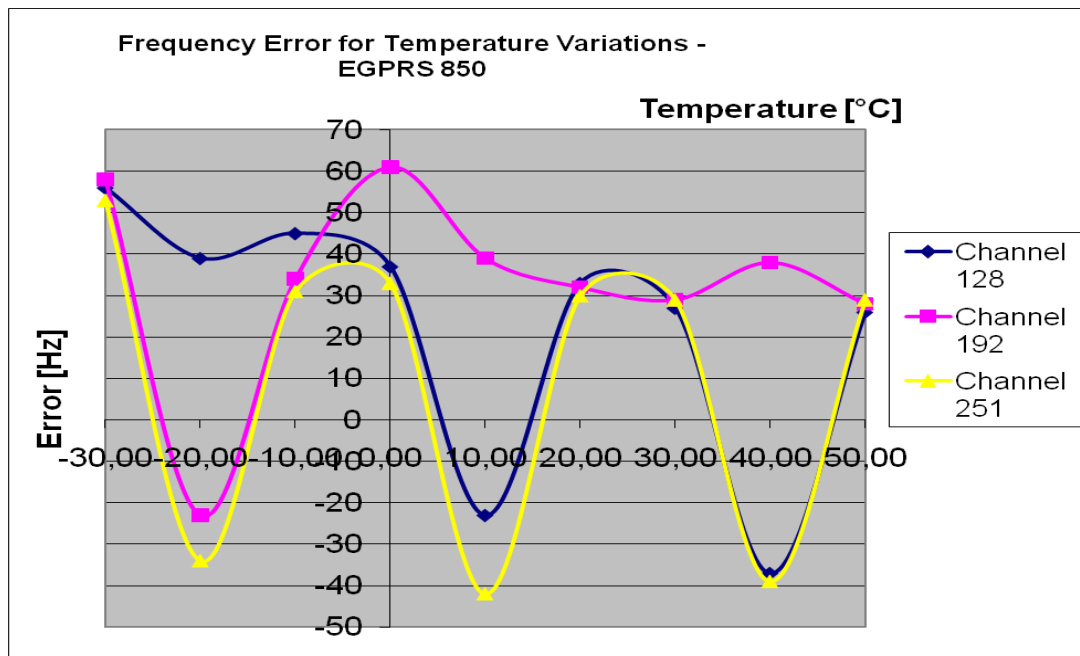

5.5.0.7. GSM1900 Mode: Op. Mode 5, set-up 2

Temperature	Maximum frequency error						Verdict
	Channel 512	Channel 661	Channel 810	Channel 512	Channel 661	Channel 810	
	[Hz]			[ppm]			
-30	-31	29	29	-0,017	0,015	0,015	Passed
-20	50	45	43	0,027	0,024	0,023	
-10	74	66	67	0,040	0,035	0,035	
0	64	71	67	0,035	0,038	0,035	
10	44	51	46	0,024	0,027	0,024	
20	17	-36	14	0,009	-0,019	0,007	
30	17	-23	14	0,009	-0,012	0,007	
40	-37	-41	37	-0,020	-0,022	0,019	
50	14	-20	-20	0,008	-0,011	-0,010	

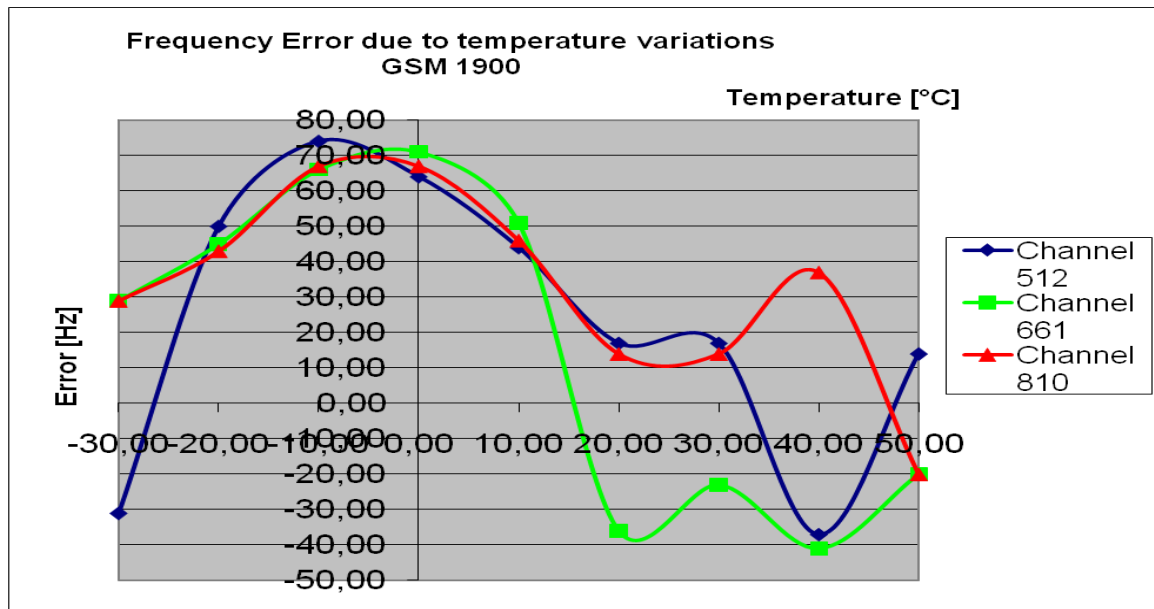

5.5.0.8. E-GPRS 1900 Mode: Op. Mode 6, set-up 2

Temperature	Maximum frequency error						Verdict
	Channel 512	Channel 661	Channel 810	Channel 512	Channel 661	Channel 810	
	[Hz]			[ppm]			
-30	69	147	67	0,037	0,078	0,035	Passed
-20	34	28	32	0,018	0,015	0,017	
-10	57	52	56	0,031	0,028	0,029	
0	114	91	105	0,062	0,048	0,055	
10	78	69	67	0,042	0,037	0,035	
20	59	59	58	0,032	0,031	0,030	
30	55	54	52	0,030	0,029	0,027	
40	67	59	59	0,036	0,031	0,031	
50	50	46	45	0,027	0,024	0,024	

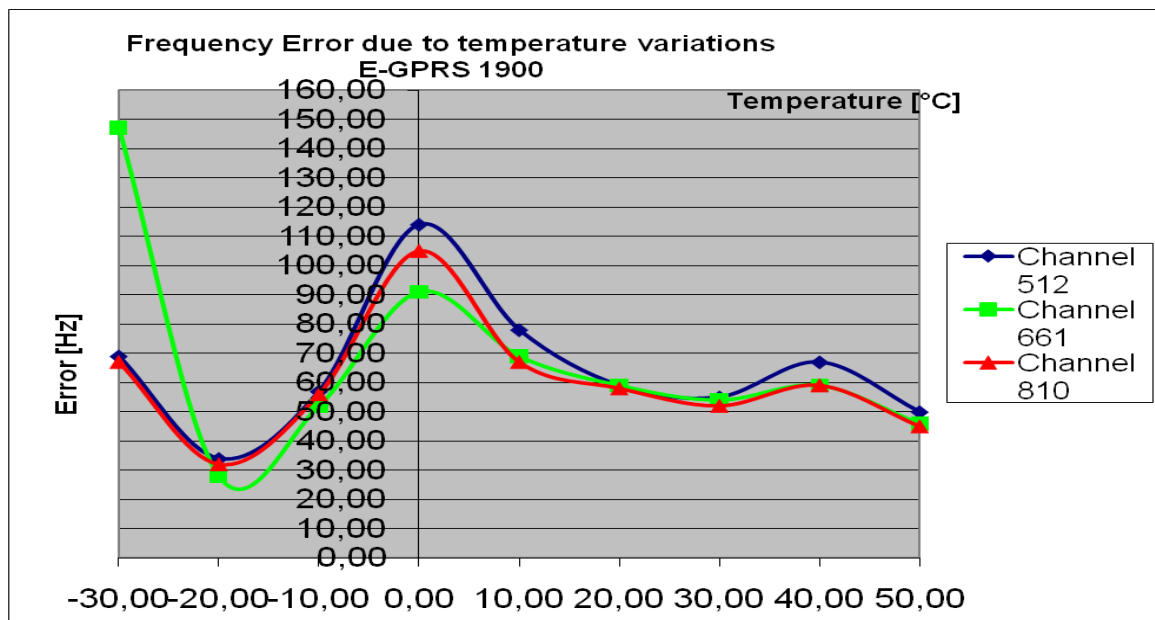

TEST EQUIPMENT

Used equipment (see reference in the annex)
CMU200 : #547
Climatic chamber : #331
POWER Supply : #354
Power attenuator : #530

6. Measurement uncertainties

The reported uncertainties are calculated based on the standard uncertainty multiplied with the appropriate coverage factor **k**, such that a confidence level of approximately 95% is achieved.

For uncertainty determination, each component used in the concrete measurement set-up was taken in account and it's contribution to the overall uncertainty according it's statistical distribution calculated.

Thus, following table shows expectable uncertainties for each measurement type performed.

Measurement	Frequency range	Calculated uncertainty based on a confidence level of 95%	Remarks:
RF-Power Output conducted	9 kHz .. 20 GHz	1 dB	--
RF-Power Output radiated	30 MHz .. 4 GHz	3,17 dB	Substitution method
Conducted RF-emissions on antenna ports	9 kHz .. 20 GHz	1 dB	--
Radiated RF-emissions enclosure	150 kHz .. 30 MHz	5 dB	Magnetic field
	30 MHz .. 1 GHz	4,2 dB	E-Field
	1GHz .. 19 GHz	3.17 dB	Substitution method
Occupied bandwidth	9 kHz .. 4 GHz	0,1272 ppm (Delta Marker method)	Frequency error
		1 dB	Power
Emission bandwidth	9 kHz .. 4 GHz	0,1272 ppm (Delta Marker method)	Frequency error
		1 dB	Power
Frequency stability	9 kHz .. 20 GHz	0,0636 ppm	--
Conducted emission on AC-mains port (U _{CISPR})	9 kHz .. 150 kHz	4 dB	--
	150 kHz .. 30 MHz	3.6 dB	

Table : measurement uncertainties valid for conducted/radiated measurements

8. Instruments and Ancillary

8.1. Used equipment “CTC”

The “Ref.-No” in the left column of the following tables allows the clear identification of the laboratory equipment.

8.1.1. Test software and firmware of equipment

Ref.-No.	Equipment	Type	Serial-No.	Version of Firmware or Software during the test
001	Emi Test Receiver	ESS	825132/017	Firm.= 1.21 , OTP=2.0, GRA=2.0
012	Signal Generator (EMS-cond.)	SMY 01	839069/027	Firm.= V 2.02
013	Power Meter (EMS cond.)	NRVD	839111/003	Firm.= V 1.51
017	Digital Radiocommunication Tester	CMD 60 M	844365/014	Firmware = V 3.52 .22.01.99, DECT = D2.87 13.01.99
053	Audio Analyzer	UPA3	860612/022	Firm. V 4,3
119	RT Harmonics Analyzer dig. Flickermeter	B10	G60547	Firm.= V 3.1DHG
140	Signal Generator	SMHU	831314/006	Firm.= 3.21
261	Thermal Power Sensor	NRV-Z55	825083/0008	EPROM-Datum 02.12.04, SE EE 1 B
262	Power Meter	NRV-S	825770/0010	Firm.= 2.6
263	Signal Generator	SMP 04	826190/0007	Firm.=3.21
264	Spectrum Analyzer	FSEK 30	826939/005	Bios=2.1, Analyzer= 3.20
295	Racal Digital Radio Test Set	6103	1572	UNIT Firmware= 4.04, SW-Main=4.04, SW-BBP=1.04, SW-DSP=1.02, Hardboot=1.02, Softboot=2.02
298	Univ. Radio Communication Tester	CMU 200	832221/091	R&S Test Firmware =3.53 /3.54 (current Testsoftw. f. all band used
323	Digital Radiocommunication Tester	CMD 55	825878/0034	Firm.= 3.52 .22.01.99
331	Climatic Test Chamber -40/+80 Grad	HC 4055	43146	TSI 1.53
335	System-CTC-EMS-Conducted	System EMS Conducted	-	EMC 32 V 8.40
340	Digital Radiocommunication Tester	CMD 55	849709/037	Firm.= 3.52 .22.01.99
355	Power Meter	URV 5	891310/027	Firm.= 1.31
365	10V Insertion Unit 50 Ohm	URV5-Z2	100880	Eprom Data = 31.03.08
366	Ultra Compact Simulator	UCS 500 M4	V0531100594	Firm. UCS 500=001925/3.06a02, rc=ISMIEC 4.10
371	Bluetooth Tester	CBT32	100153	CBT V5.30+ SW-Option K55
377	Emi Test Receiver	ESCS 30	100160	Firm.= 2.30, OTP= 02.01, GRA= 02.36
378	Broadband RF Field Monitor	RadiSense III	03D00013SNO-08	Firm.= V.03D13
383	Signal Generator	SME 03	842 828 /034	Firm.= 4.61
389	Digital Multimeter	Keithley 2000	0583926	Firm. = A13 (Mainboard) A02 (Display)
392	Radio Communication Tester	MT8820A	6K00000788	Firm.= 4.50 #005, IPL=4.01#001,OS=4.02#001, GSM=4.41#013, W-CDMA= 4.54#004, scenario= 4.52#002
436	Univ. Radio Communication Tester	CMU 200	103083	R&S Test Firmware Base=5.14, Mess-Software= GSM:5.14 WCDMA:5.14 (current Testsoftw. F. all band to be used ,
441	CTC-SAR-EMI Cable Loss	System EMI field (SAR) Cable	-	EMC 32 Version 8.40
442	CTC-SAR-EMS	System EMS field (SAR)	-	EMC 32 Version 8.40
443	CTC-FAR-EMI-RSE	System CTC-FAR-EMI-RSE	-	Spuri 7.2.5 or EMC 32 Ver. 8.40
444	CTC-FAR-EMS field	System-EMS-Field (FAR)	-	EMC 32 Version 8.40
460	Univ. Radio Communication Tester	CMU 200	108901	R&S Test Firmware Base=5.14, GSM=5.14 WCDMA=5.14 (current Testsoftw.,f. all band to be used,
489	Emi Test Receiver	ESU40	1000-30	Firmware=4.43 SP3, Bios=V5.1-16-3, Spec. =01.00
491	ESD Simulator dito	ESD dito	dito307022	V 2.30
524	Voltage Drop Simulator	VDS 200	0196-16	Software Nr: 000037 Version V4.20a01
526	Burst Generator	EFT 200 A	0496-06	Software Nr. 000034 Version V2.32
527	Micro Pulse Generator	MPG 200 B	0496-05	Software-Nr. 000030 Version V2.43
528	Load Dump Simulator	LD 200B	0496-06	Software-Nr. 000031 Version V2.35a01
546	Univ. Radio Communication Tester	CMU 200	106436	R&S Test Firmware Base=5.14, GSM=5.14 WCDMA=5.14 (current Testsoftw.,f. all band to be used
547	Univ. Radio Communication Tester	CMU 200	835390/014	R&S Test Firmware Base=V5.1403 (current Testsoftw., f. all band used, GSM = 5.14 WCDMA: = 5.14
584	Spectrum Analyzer	FSU 8	100248	2.82_SP3
594	Univ. Radio Communication Tester	CMW500	101757	Firmware Base=2.0.20.9, LTE=2.0.20.8. CDMA= 2.0.10
597	Univ. Radio Communication Tester	CMU 200	100347	R&S Test Firmware Base=5.01, GSM=5.02 WCDMA= not installed, Mainboard= µP1=V.850
598	Spectrum Analyzer	FSEM 30 (Reserve)	831259/013	Firmware Bios 3.40 , Analyzer 3.40 Sp 2

8.1.2. Single instruments and test systems

Ref.-No.	Equipment	Type	Serial-No.	Manufacturer	Interval of calibration	Remark	Cal due
001	Emi Test Receiver	ESS	825132/017	Rohde & Schwarz	12 M	-	31.03.2012
005	AC - LISN (50 Ohm/50µH, test site 1)	ESH2-Z5	861741/005	Rohde & Schwarz	24/12 M	-	31.03.2012
007	DC - LISN (50 Ohm/5µH)	ESH3-Z6	892563/002	Rohde & Schwarz	24/12 M	-	31.03.2012
009	Power Meter (EMS-radiated)	NRV	863056/017	Rohde & Schwarz	24 M	-	31.03.2013
016	Line Impedance Simulating Network	Op. 24-D	B6366	Spitzenberger+Spies	36 M	-	31.03.2013
020	Horn Antenna 18 GHz (Subst 1)	3115	9107-3699	EMCO	36/12 M	-	31.03.2013
021	Loop Antenna (H-Field)	6502	9206-2770	EMCO	36 M	-	31.03.2013
030	Loop Antenna (H-field)	HFH-Z2	879604/026	Rohde & Schwarz	36 M	-	31.03.2012
033	RF-current probe (100kHz-30MHz)	ESH2-Z1	879581/18	Rohde & Schwarz	24 M	-	31.03.2013
057	relay-switch-unit (EMS system)	RSU	494440/002	Rohde & Schwarz	pre-m	1a	
060	power amplifier (DC-2kHz)	PAS 5000	B6363	Spitzenberger+Spies	-	3	
066	notch filter (WCDMA; FDD1)	WRCT 1900/2200-5/40-10EEK	5	Wainwright GmbH	12 M	1c	30.06.2012
086	DC - power supply, 0 -10 A	LNG 50-10	-	Heinzinger Electronic	pre-m	2	
087	DC - power supply, 0 -5 A	EA-3013 S	-	Elektro Automatik	pre-m	2	
090	Helmholtz coil: 2x10 coils in series	-	-	RWTÜV	-	4	
091	USB-LWL-Converter	OLS-1	007/2006	Ing. Büro Scheiba	-	4	
099	passive voltage probe	ESH2-Z3	299.7810.52	Rohde & Schwarz	36 M	-	31.03.2012
100	passive voltage probe	Probe TK 9416	without	Schwarzbeck	36 M	-	31.03.2012
110	USB-LWL-Converter	OLS-1	-	Ing. Büro Scheiba	-	4	
119	RT Harmonics Analyzer dig. Flickermeter	B10	G60547	BOCONSULT	36 M	-	31.03.2013
134	horn antenna 18 GHz (Subst 2)	3115	9005-3414	EMCO	12 M	-	31.03.2012
136	adjustable dipole antenna (Dipole 1)	3121C-DB4	9105-0697	EMCO	12 M	-	31.03.2012
140	Signal Generator	SMHU	831314/006	Rohde & Schwarz	24 M	-	31.03.2012
248	attenuator	SMA 6dB 2W	-	Radiall	pre-m	2	
249	attenuator	SMA 10dB 10W	-	Radiall	pre-m	2	
252	attenuator	N 6dB 12W	-	Radiall	pre-m	2	
256	attenuator	SMA 3dB 2W	-	Radiall	pre-m	2	
257	hybrid	4031C	04491	Narda	pre-m	2	
260	hybrid coupler	4032C	11342	Narda	pre-m	2	
261	Thermal Power Sensor	NRV-Z55	825083/0008	Rohde & Schwarz	24/12 M	-	31.03.2012
262	Power Meter	NRV-S	825770/0010	Rohde & Schwarz	24 M	-	31.03.2012
263	Signal Generator	SMP 04	826190/0007	Rohde & Schwarz	36 M	-	31.03.2013
264	Spectrum Analyzer	FSEK 30	826939/005	Rohde & Schwarz	12 M	-	31.03.2014
265	peak power sensor	NRV-Z33, Model 04	840414/009	Rohde & Schwarz	24 M	-	31.03.2012
266	peak power sensor	NRV-Z31, Model 04	843383/016	Rohde & Schwarz	24 M	-	31.03.2012
267	notch filter GSM 850	WRCA 800/960-6EEK	9	Wainwright GmbH	pre-m	2	
268	AC/DC power supply	EA 3050-A	9823636	Elektro Automatik	pre-m	2	
270	termination	1418 N	BB6935	Weinschel	pre-m	2	
271	termination	1418 N	BE6384	Weinschel	pre-m	2	
272	attenuator (20 dB) 50 W	Model 47	BF6239	Weinschel	pre-m	2	
273	attenuator (10 dB) 100 W	Model 48	BF9229	Weinschel	pre-m	2	
274	attenuator (10 dB) 50 W	Model 47 (10 dB) 50 W	BG0321	Weinschel	pre-m	2	
275	DC-Block	Model 7003 (N)	C5129	Weinschel	pre-m	2	
276	DC-Block	Model 7006 (SMA)	C7061	Weinschel	pre-m	2	
279	power divider	1515 (SMA)	LH855	Weinschel	pre-m	2	
287	pre-amplifier 25MHz - 4GHz	AMF-2D-100M4G-35-10P	379418	Miteq	12 M	1c	30.06.2012
291	high pass filter GSM 850/900	WHJ 2200-4EE	14	Wainwright GmbH	12 M	1c	30.06.2012
298	Univ. Radio Communication Tester	CMU 200	832221/091	Rohde & Schwarz	pre-m	3	
300	AC LISN (50 Ohm/50µH, 1-phase)	ESH3-Z5	892 239/020	Rohde & Schwarz	24/12 M	-	31.03.2012
301	attenuator (20 dB) 50W, 18GHz	47-20-33	AW0272	Lucas Weinschel	pre-m	2	
302	horn antenna 40 GHz (Meas 1)	BBHA9170	155	Schwarzbeck	36 M	-	31.03.2014
303	horn antenna 40 GHz (Subst 1)	BBHA9170	156	Schwarzbeck	36 M	-	31.03.2014
331	Climatic Test Chamber -40/+80 Grad	HC 4055	43146	Heraeus Vötsch	24 M	-	30.11.2012
341	Digital Multimeter	Fluke 112	81650455	Fluke	24 M	-	31.03.2012
342	Digital Multimeter	Voltcraft M-4660A	IB 255466	Voltcraft	24 M	-	31.03.2013
347	laboratory site	radio lab.	-	-	-	5	
348	laboratory site	EMI conducted	-	-	-	5	
354	DC - Power Supply 40A	NGPE 40/40	448	Rohde & Schwarz	pre-m	2	
355	Power Meter	URV 5	891310/027	Rohde & Schwarz	24 M	-	31.03.2012
356	power sensor	NRV-Z1	882322/014	Rohde & Schwarz	24 M	-	31.03.2013
357	power sensor	NRV-Z1	861761/002	Rohde & Schwarz	24 M	-	31.03.2013
373	V-Network 5µH/50 Ohm	ESH3-Z6	100535	Rohde & Schwarz	24/12 M	-	31.03.2012
376	Horn Antenna 6 GHz	BBHA9120 E	BBHA 9120 E 179	Schwarzbeck	12 M	-	31.03.2012
377	Emi Test Receiver	ESCS 30	100160	Rohde & Schwarz	12 M	-	31.03.2012
389	Digital Multimeter	Keithley 2000	0583926	Keithley	24 M	-	31.03.2013
392	Radio Communication Tester	MT8820A	6K00000788	Anritsu	12 M	-	31.03.2012
431	Model 7405	Near-Field Probe Set	9305-2457	EMCO	-	4	
436	Univ. Radio Communication Tester	CMU 200	103083	Rohde & Schwarz	12 M	-	31.03.2012
441	CTC-SAR-EMI Cable Loss	System EMI field (SAR)	-	CETECOM	12 M	5	31.08.2011

Ref.-No.	Equipment	Type	Serial-No.	Manufacturer	Interval of calibration	Remark	Cal due
		Cable					
443	CTC-FAR-EMI-RSE	System CTC-FAR-EMI-RSE	-	ETS-Lindgren/CETECOM	12 M	5	30.06.2012
448	notch filter WCDMA_FDD II	WRCT 1850.0/2170.0-5/40-10SSK	5	Wainwright Instruments GmbH	12 M	1c	30.06.2012
449	notch filter WCDMA FDD V	WRCT 824.0/894.0-5/40-8SSK	1	Wainwright	12 M	1c	30.06.2012
454	Oscilloscope	HM 205-3	9210 P 29661	Hameg	-	4	
456	DC-Power supply 0-5 A	EA 3013 S	207810	Elektro Automatik	pre-m	2	
459	DC -Power supply 0-5 A , 0-32 V	EA-PS 2032-50	910722	Elektro Automatik	pre-m	2	
460	Univ. Radio Communication Tester	CMU 200	108901	Rohde & Schwarz	12 M	-	31.03.2012
463	Universal source	HP3245A	2831A03472	Agilent	-	4	
466	Digital Multimeter	Fluke 112	89210157	Fluke USA	24 M	-	31.03.2012
467	Digital Multimeter	Fluke 112	89680306	Fluke USA	24 M	-	31.03.2012
468	Digital Multimeter	Fluke 112	90090455	Fluke USA	24 M	-	31.03.2012
477	ReRadiating GPS-System	AS-47	-	Automotive Cons. Fink	-	3	
480	power meter (Fula)	NRVS	838392/031	Rohde & Schwarz	24 M	-	31.03.2013
482	filter matrix	Filter matrix SAR 1	-	CETECOM (Brl)	-	1d	
484	pre-amplifier 2,5 - 18 GHz	AMF-5D-02501800-25-10P	1244554	Miteq	12 M	-	30.07.2012
487	System CTC NSA-Verification SAR-EMI	System EMI field (SAR) NSA	-	ETS Lindgren/CETECOM	12 M	-	30.09.2011
489	Emi Test Receiver	ESU40	1000-30	Rohde & Schwarz	12 M	-	31.03.2012
502	band reject filter	WRCG 1709/1786-1699/1796-	SN 9	Wainwright	pre-m	2	
503	band reject filter	WRCG 824/849-814/859-60/10SS	SN 5	Wainwright	pre-m	2	
512	notch filter GSM 850	WRCA 800/960-02/40-6EEK	SN 24	Wainwright	12 M	1c	30.06.2012
517	relais switch matrix	HF Relais Box Keithley System	SE 04	Keithley	pre-m	2	
523	Digital Multimeter	L4411A	MY46000154	Agilent	24 M	-	31.03.2013
529	6 dB Broadband resistive power divider	Model 1515	LH 855	Weinschel	pre-m	2	
546	Univ. Radio Communication Tester	CMU 200	106436	R&S	12 M	-	31.03.2012
547	Univ. Radio Communication Tester	CMU 200	835390/014	Rohde & Schwarz	12 M	-	31.03.2012
548	Digital-Barometer	GBP 2300	without	Greisinger GmbH	36/12 M	-	31.03.2012
549	Log-Per-Antenna	HL025	1000060	Rohde & Schwarz	36/12 M	-	31.03.2012
552	high pass filter 2,8-18GHz	WHKX 2.8/18G-10SS	4	Wainwright	12 M	1c	30.07.2012
558	System CTC FAR S-VSWR	System CTC FAR S-VSWR	-	CTC	24 M	-	31.07.2013
574	Biconilog Hybrid Antenna	BTA-L	980026L	Frankonia	36/12 M	-	30.03.2013
584	Spectrum Analyzer	FSU 8	100248	Rohde & Schwarz	12 M	-	31.03.2012
594	Univ. Radio Communication Tester	CMW500	101757	Rohde & Schwarz	24 M	-	31.03.2012
597	Univ. Radio Communication Tester	CMU 200	100347	Rohde & Schwarz	12 M	-	31.03.2012
598	Spectrum Analyzer	FSEM 30 (Reserve)	831259/013	Rohde & Schwarz	24 M	-	13.01.2013
600	power meter	NRVD (Reserve)	834501/018	Rohde & Schwarz	24 M	-	31.03.2013
601	medium-sensitivity diode sensor	NRV-Z5 (Reserve)	8435323/003	Rohde & Schwarz	24 M	-	12.01.2013
602	peak power sensor	NRV-Z32 (Reserve)	835080	Rohde & Schwarz	24 M	-	12.01.2013
608	UltraLog-Antenna	HL 562	830547/009	Rohde & Schwarz	36/12 M	-	31.03.2014
611	DC power supply	E3632A	KR 75305854	Agilent	pre-m	2	
612	DC power supply	E3632A	MY 40001321	Agilent	pre-m	2	
613	Attenuator	R416120000 20dB 10W	Lot. 9828	Radiall	pre-m	2	

8.1.3. Legend

Note / remarks		Calibrated during system calibration:
	1a	System CTC-SAR-EMS (Ref.-No. 442)
	1b	System-CTC-EMS-Conducted (Ref.-No. 335)
	1c	System CTC-FAR-EMI-RSE (Ref.-No. 443)
	1d	System CTC-SAR-EMI (Ref.-No. 441)
	1e	System CTC-OATS (EMI radiated) (Ref.-No. 337)
	1 f	System CTC-CTIA-OTA (Ref.-No. 420)
	1 g	System CTC-FAR-EMS (Ref.-No. 444)
	2	Calibration or equipment check immediately before measurement
	3	Regulatory maintained equipment for functional check or support purpose
	4	Ancillary equipment without calibration e.g. mechanical equipment or monitoring equipment
	5	Test System

Interval of calibration	12 M	12 month
-------------------------	------	----------

	24 M	24 month
	36 M	36 month
	24/12 M	Calibration every 24 months, between this every 12 months internal validation
	36/12 M	Calibration every 36 months, between this every 12 months internal validation
	Pre-m	Check before starting the measurement
	-	Without calibration