

CETECOM™

CETECOM ICT Services
consulting - testing - certification >>>

TEST REPORT

Test report no.: 1-2977-30-09/11



Testing laboratory

CETECOM ICT Services GmbH
Untertuerkheimer Strasse 6 – 10
66117 Saarbruecken / Germany
Phone: + 49 681 5 98 - 0
Fax: + 49 681 5 98 - 9075
Internet: <http://www.cetecom.com>
e-mail: ict@cetecom.com

Accredited test laboratory:

The test laboratory (area of testing) is accredited according to DIN EN ISO/IEC 17025
DAR registration number: DGA-PL-176/94-D1

Area of Testing: Radio/Satellite Communications

Applicant

Sony Ericsson Mobile Communications AB

Nya Vattentornet
22188 Lund / Sweden
Phone: +46 46 19 30 00
Fax: +46 46 19 32 95
Contact: Johan Wedin
e-mail: johan.wedin@sonyericsson.com
Phone: +46 70 71 95 73 6

Manufacturer

Sony Ericsson Mobile Communications AB

Nya Vattentornet
22188 Lund / Sweden

Test standard/s

47 CFR Part 15

Title 47 of the Code of Federal Regulations; Chapter I
Part 15 - Radio frequency devices

RSS - 210 Issue 8

Spectrum Management and Telecommunications - Radio Standards Specification
Low-power Licence-exempt Radiocommunication Devices (All Frequency Bands): Category I
Equipment

For further applied test standards please refer to section 3 of this test report.

Test item

Kind of test item: GSM Mobile Phone (GPRS/EGPRS) 850/900/1800/1900; UMTS (HSDPA/HSUPA)
FDDI/V/VI; BT2.1 + EDR; A-GPS, WLAN, ANT+, RFID
Model name: AAD-3880112-BV
FCC ID: PY7A3880112
IC: 4170B-A3880112
Frequency: ISM band 2400 – 2483.5 MHz
(lowest channel 2402 MHz – highest channel 2480 MHz)
Power supply: 3.7 V DC by Li-Polymer Battery BA750
Temperature range: -20 °C to +55 °C

Test performed:

2011-04-27  Joerg Warken

Test report authorised:

2011-04-27  Michael Berg

1 Table of contents	
1	Table of contents2
2	General information3
2.1	Notes.....3
2.2	Application details.....3
3	Test standard/s3
4	Test environment.....3
5	Test item4
6	Test laboratories sub-contracted4
7	Summary of measurement results5
8	RF measurement testing.....6
8.1	Description of test setup6
8.1.1	Radiated measurements.....6
8.1.2	Conducted measurements.....7
8.2	Additional comments7
8.3	RSP100 test report cover sheet / performance test data8
9	Measurement results.....9
9.1	Maximum output power9
9.2	Antenna gain12
9.3	Power spectral density13
9.4	Spectrum bandwidth of a DSSS system – 6 dB bandwidth17
9.5	Spectrum bandwidth of a DSSS system – 20 dB bandwidth20
9.6	Band edge compliance conducted23
9.7	Band edge compliance radiated25
9.8	TX spurious emissions conducted27
9.9	TX spurious emissions radiated30
9.10	RX spurious emissions radiated39
9.11	TX spurious emissions radiated < 30 MHz43
9.12	TX spurious emissions conducted < 30 MHz.....45
10	Test equipment and ancillaries used for tests47
Annex A	Photographs of the test setup50
Annex B	Document history60
Annex C	Further information60

2 General information

2.1 Notes

The test results of this test report relate exclusively to the test item specified in this test report. CETECOM ICT Services GmbH does not assume responsibility for any conclusions and generalisations drawn from the test results with regard to other specimens or samples of the type of the equipment represented by the test item. The test report may only be reproduced or published in full. Reproduction or publication of extracts from the report requires the prior written approval of CETECOM ICT Services GmbH.

2.2 Application details

Date of receipt of order:	2011-04-07
Date of receipt of test item:	2011-04-07
Start of test:	2011-04-07
End of test:	2011-04-21
Person(s) present during the test:	--

3 Test standard/s

Test standard	Version	Test standard description
47 CFR Part 15	2009-10	Title 47 of the Code of Federal Regulations; Chapter I Part 15 - Radio frequency devices
RSS - 210 Issue 8	2010-12	Spectrum Management and Telecommunications - Radio Standards Specification Low-power Licence-exempt Radiocommunication Devices (All Frequency Bands): Category I Equipment

4 Test environment

Temperature:	T_{nom}	+20 °C during room temperature tests
	T_{max}	+55 °C during high temperature test
	T_{min}	-20 °C during low temperature test
Relative humidity content:		54 %
Air pressure:		not relevant for this kind of testing
Power supply:	V_{nom}	3.7 V DC by Li-Polymer Battery BA750
	V_{max}	4.1 V
	V_{min}	3.4 V

5 Test item

Kind of test item	:	GSM Mobile Phone (GPRS/EGPRS) 850/900/1800/1900; UMTS (HSDPA/HSUPA) FDDI/V/VI; BT2.1 + EDR; A-GPS, WLAN, ANT+, RFID
Type identification	:	AAD-3880112-BV
S/N serial number	:	Radiated: CB5A1CH5KW, CB5A1CH5QV Conducted: CB5A1CH5KH, CB5A1CH5ZF
HW hardware status	:	AP1.1
SW software status	:	3.0.1.F.0.25 ATP R1A034 Private
Frequency band [MHz]	:	ISM band 2400 – 2483.5 MHz (lowest channel 2402 MHz – highest channel 2480 MHz)
Type of modulation	:	DSSS using GFSK modulation
Number of channels	:	79
Antenna	:	Integrated PCB antenna → for more information, please take a look at the annex – internal photos of the EUT.
Power supply	:	3.7 V DC by Li-Polymer Battery BA750
Temperature range	:	-20°C to +55 °C

6 Test laboratories sub-contracted

None

7 Summary of measurement results

- No deviations from the technical specifications were ascertained
- There were deviations from the technical specifications ascertained

TC Identifier	Description	Verdict	Date	Remark
RF-Testing	CFR Part 15 RSS 210, Issue 8, Annex 8	Passed	2011-04-27	-/-

Test specification clause	Test case	Temperature conditions	Power source voltages	Mode	Pass	Fail	NA	NP	Results (max.)
§15.247(b)(4) RSS 210 / A8.4(2)	Antenna gain	Nominal	Nominal	DSSS	<input checked="" type="checkbox"/>	<input type="checkbox"/>	<input type="checkbox"/>	<input type="checkbox"/>	complies
§15.247(e) RSS 210 / A8.2(b)	Power spectral density	Nominal	Nominal	DSSS	<input checked="" type="checkbox"/>	<input type="checkbox"/>	<input type="checkbox"/>	<input type="checkbox"/>	complies
§15.247(a)(2) RSS 210 / A8.2(a)	Spectrum bandwidth of a DSSS system 6dB bandwidth	Nominal	Nominal	DSSS	<input checked="" type="checkbox"/>	<input type="checkbox"/>	<input type="checkbox"/>	<input type="checkbox"/>	complies
§15.247(a)(2) RSS 210 / A8.2(a)	Spectrum bandwidth of a DSSS system 20dB bandwidth	Nominal	Nominal	DSSS	<input checked="" type="checkbox"/>	<input type="checkbox"/>	<input type="checkbox"/>	<input type="checkbox"/>	complies
§15.247(b)(3) RSS-210 / A8.4(4)	Maximum output power	Nominal	Nominal	DSSS	<input checked="" type="checkbox"/>	<input type="checkbox"/>	<input type="checkbox"/>	<input type="checkbox"/>	complies
§15.247(d) RSS-210 / A8.5	Band edge compliance conducted	Nominal	Nominal	DSSS	<input checked="" type="checkbox"/>	<input type="checkbox"/>	<input type="checkbox"/>	<input type="checkbox"/>	complies
§15.205 RSS-210 / A8.5	Band edge compliance radiated	Nominal	Nominal	DSSS	<input checked="" type="checkbox"/>	<input type="checkbox"/>	<input type="checkbox"/>	<input type="checkbox"/>	complies
§15.247(d) RSS-210 / A8.5	TX spurious emissions conducted	Nominal	Nominal	DSSS	<input checked="" type="checkbox"/>	<input type="checkbox"/>	<input type="checkbox"/>	<input type="checkbox"/>	complies
§15.247(d) RSS-210 / A8.5	TX spurious emissions radiated	Nominal	Nominal	DSSS	<input checked="" type="checkbox"/>	<input type="checkbox"/>	<input type="checkbox"/>	<input type="checkbox"/>	complies
§15.109 RSS-Gen.	RX spurious emissions radiated	Nominal	Nominal	-/-	<input checked="" type="checkbox"/>	<input type="checkbox"/>	<input type="checkbox"/>	<input type="checkbox"/>	complies
§15.209(a) RSS-Gen	TX spurious emissions radiated < 30 MHz	Nominal	Nominal	DSSS	<input checked="" type="checkbox"/>	<input type="checkbox"/>	<input type="checkbox"/>	<input type="checkbox"/>	complies
§15.107(a)	Conducted emissions < 30 MHz	Nominal	Nominal	DSSS	<input checked="" type="checkbox"/>	<input type="checkbox"/>	<input type="checkbox"/>	<input type="checkbox"/>	complies

Note: NA = Not Applicable; NP = Not Performed

8 RF measurement testing

8.1 Description of test setup

8.1.1 Radiated measurements

The radiated measurements are performed in vertical and horizontal plane in the frequency range from 9 kHz to 25 GHz in semi-anechoic chambers. The EUT is positioned on a non-conductive support with a height of 0.80 m above a conductive ground plane that covers the whole chamber. The receiving antennas are confirmed with specifications ANSI C63.2-1996 clause 15 and ANSI C63.4-2009 clause 4.1.5. These antennas can be moved over the height range between 1.0 m and 4.0 m in order to search for maximum field strength emitted from EUT. The measurement distances between EUT and receiving antennas are indicated in the test setups for the various frequency ranges. For each measurement, the EUT is rotated in all three axes until the maximum field strength is received. The wanted and unwanted emissions are received by spectrum analysers where the detector modes and resolution bandwidths over various frequency ranges are set according to requirement ANSI C63-4-2009 clause 4.2.

Antennas are confirmed with ANSI C63.2-1996 item 15.

Semi anechoic chamber

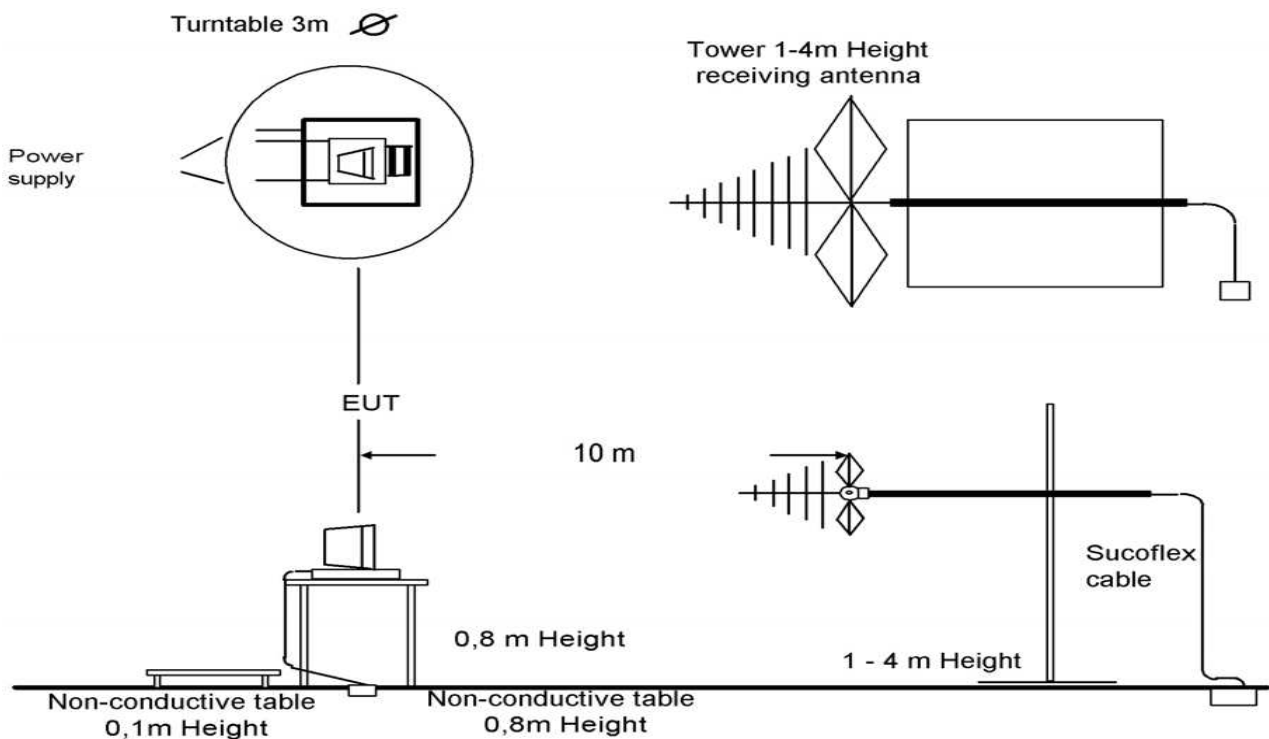

Picture 1: Diagram radiated measurements

9 kHz - 30 MHz:	active loop antenna
30 MHz – 1 GHz:	tri-log antenna
> 1 GHz:	horn antenna

The EUT is powered by an external power supply with nominal voltage

8.1.2 Conducted measurements

The EUT's RF signal is coupled out by the antenna connector which is supplied by the manufacturer. The signal is first 10dB attenuated before it is power divided (~6dB loss per branch). One of the signal paths is connected to the communication base Station (CMU200 or other), the other one is connected to the spectrum analyzer. The specific losses for both signal paths are first checked within a calibration. The measurement readings on the signalling unit/spectrum analyzer are corrected by the specific test set-up loss. The attenuator, power divider, signalling unit and the spectrum analyzer are impedance matched on 50 Ohm.

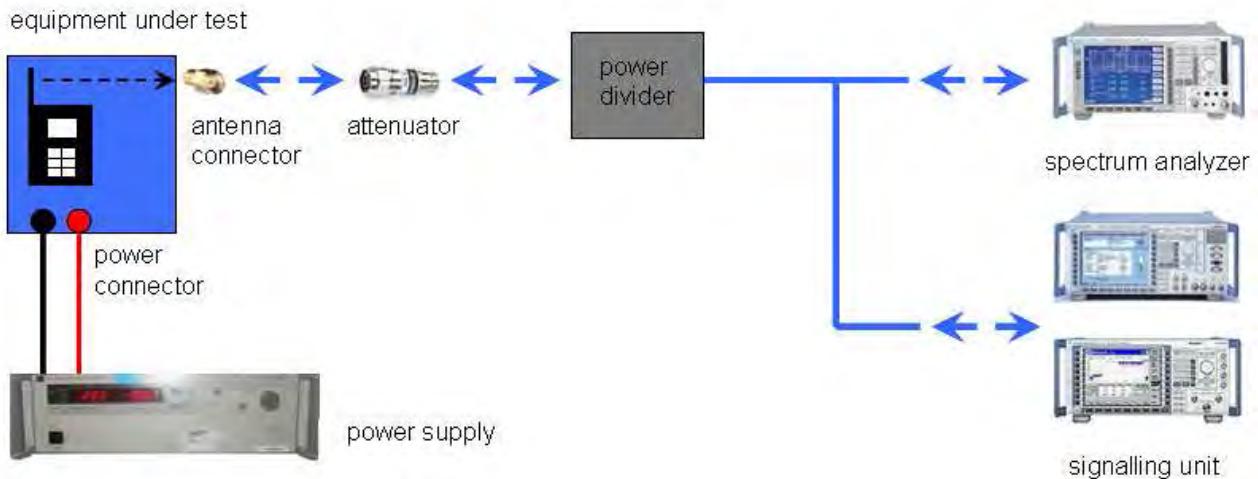

Picture 2: Diagram conducted measurements

8.2 Additional comments

Reference documents: None

Special test descriptions: None

Configuration descriptions: None

- Test mode:
- No test mode available.
lperf was used to ping another device with the largest support packet size
 - Special software is used.
EUT is transmitting pseudo random data by itself

8.3 RSP100 test report cover sheet / performance test data

Test report number	:	1-2977-30-09/11
Equipment model number	:	AAD-3880112-BV
Certification number	:	4170B-A3880112
Manufacturer (complete address)	:	Sony Ericsson Mobile Communications AB Nya Vattentorget 22188 Lund / Sweden
Tested to radio standards specification no.	:	RSS 210, Issue 8, Annex 8
Open area test site IC No.	:	IC 3462C-1
Frequency range	:	ISM band 2400 MHz to 2483.5 MHz (lowest channel 2402 MHz, highest channel 2480 MHz)
RF-power [W] (max.)	:	cond.: 4.57mW EIRP: 1.51mW
Occupied bandwidth (99%-BW) [kHz]	:	1106
Type of modulation	:	DSSS technology with GFSK modulation.
Emission designator (TRC-43)	:	1M11FXD (DSSS)
Antenna information	:	Integrated PCB antenna
Transmitter spurious (worst case)	:	50.3 dBµV/m (noise floor)
Receiver spurious (worst case)	:	52.1 dBµV/m

ATTESTATION:
DECLARATION OF COMPLIANCE:

I attest that the testing was performed or supervised by me; that the test measurements were made in accordance with the above-mentioned Industry Canada standard(s); and that the equipment identified in this application has been subjected to all the applicable test conditions specified in the Industry Canada standards and all of the requirements of the standard have been met.

Laboratory manager:

2011-04-27
Date

Joerg Warken
Name

Signature



9 Measurement results

9.1 Maximum output power

Description:

Measurement of the maximum output power conducted and radiated

Measurement:

Measurement parameter	
Detector:	Peak
Sweep time:	Auto
Video bandwidth:	3 MHz
Resolution bandwidth:	3 MHz
Span:	3 MHz
Trace-Mode:	Max Hold

Result:

Modulation	Maximum output power conducted [dBm]		
	2402 MHz	2441 MHz	2480 MHz
Frequency			
GFSK	6.5	6.6	6.2
Measurement uncertainty	± 1.5 dB		

Modulation	Maximum output power radiated - EIRP [dBm]		
	2402 MHz	2441 MHz	2480 MHz
Frequency			
GFSK	1.3	1.8	1.7
Measurement uncertainty	± 3 dB		

Result: [The result of the measurement is passed.](#)

Plots: DSSS / ANT+ (conducted)

Plot 1: TX mode, lowest channel

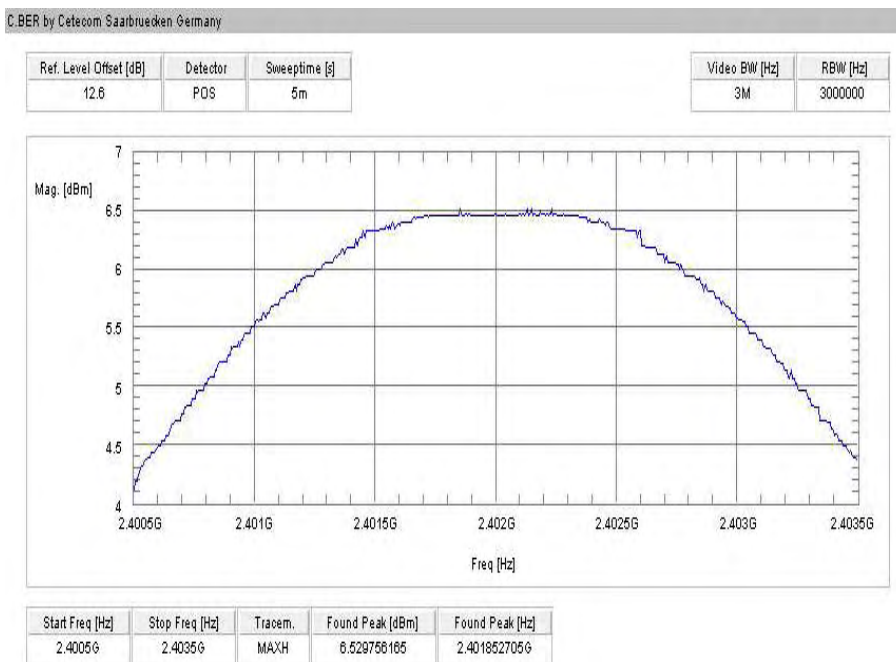

Plot 2: TX mode, middle channel

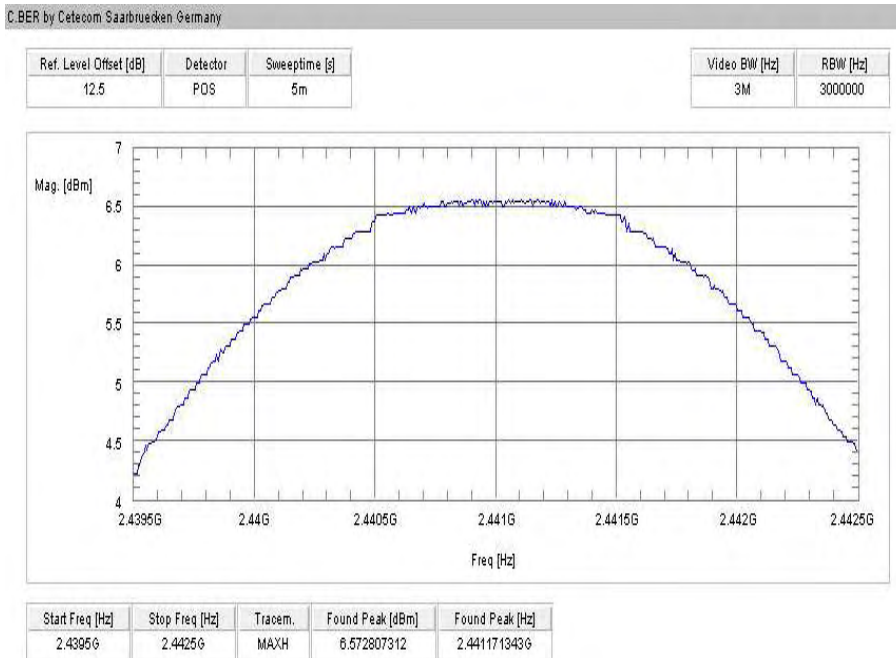

Plot 3: TX mode, highest channel

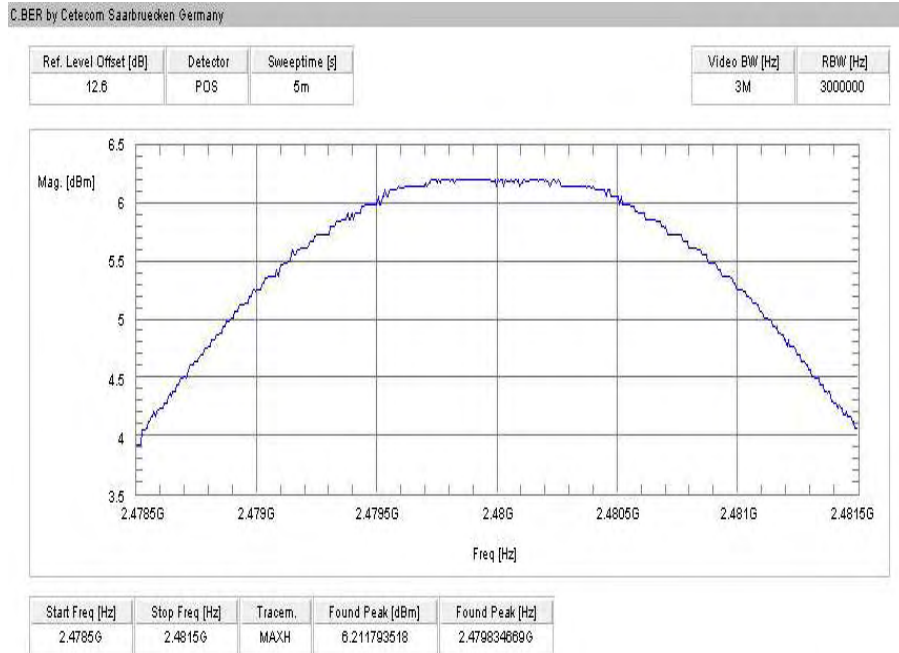

9.2 Antenna gain

Measurement:

The antenna gain of the complete system is calculated by the difference of radiated power in EIRP and the conducted power of the module.

Measurement parameters:

Measurement parameter	
Detector:	Peak
Sweep time:	Auto
Video bandwidth:	3 MHz
Resolution bandwidth:	3 MHz
Span:	3 MHz
Trace-Mode:	Max hold

Limits:

FCC	IC
CFR Part 15.247 (b)(4)	RSS 210, Issue 8, A 8.4(2)
Antenna Gain	
6 dBi	

Results:

T _{nom}	V _{nom}	lowest channel 2402 MHz	middle channel 2441 MHz	highest channel 2480 MHz
Conducted power [dBm] Measured with DSSS modulation		6.5	6.6	6.2
Radiated power [dBm] Measured with DSSS modulation		1.3	1.8	1.7
Gain [dBi] Calculated		-5.2	-4.8	-4.5

Result: The result of the measurement is passed.

9.3 Power spectral density

Description:

Measurement of the power spectral density of a digital modulated system. The measurement is repeated at the lowest, middle and highest channel.

Measurement:

Measurement parameter	
Detector:	Peak
Sweep time:	500 s
Video bandwidth:	3 kHz
Resolution bandwidth:	3 kHz
Span:	1.5 MHz
Trace-Mode:	Max Hold

Limits:

FCC	IC
CFR Part 15.247 (e)	RSS 210, Issue 8, A 8.2(b)
Power Spectral Density	
The transmitter power spectral density conducted from the transmitter to the antenna shall not be greater than 8 dBm in any 3 kHz band during any time interval of continuous transmission or over 1.0 second if the transmission exceeds 1.0-second duration.	

Results:

Modulation	Power Spectral density [dBm/3kHz]			
	Frequency	2402 MHz	2441 MHz	2480 MHz
DSSS		-5.4	-5.3	-7.0
Measurement uncertainty		± 1.5 dB		

Result: The result of the measurement is passed.

Plots: DSSS / ANT+

Plot 1: lowest channel

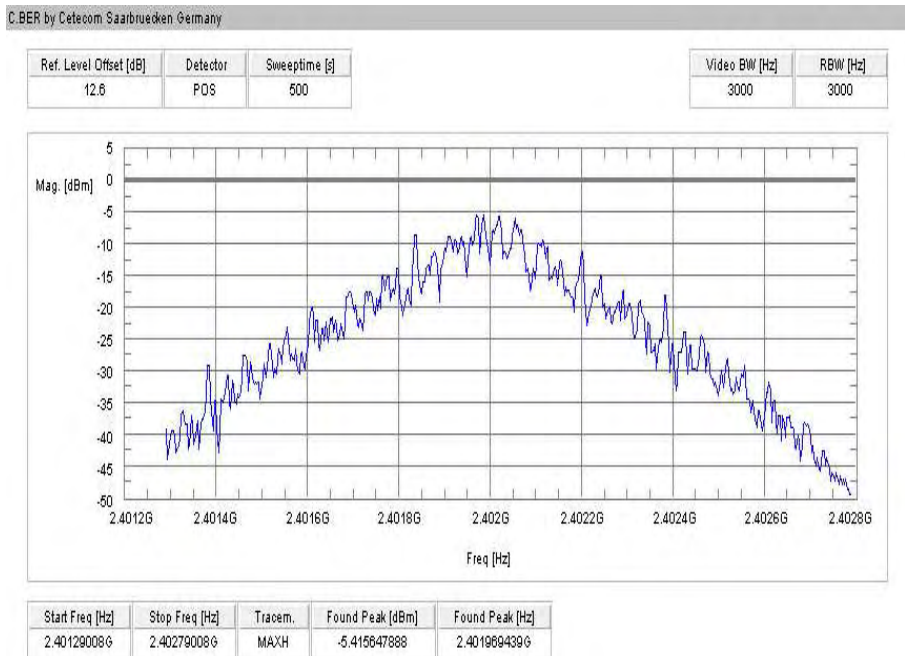
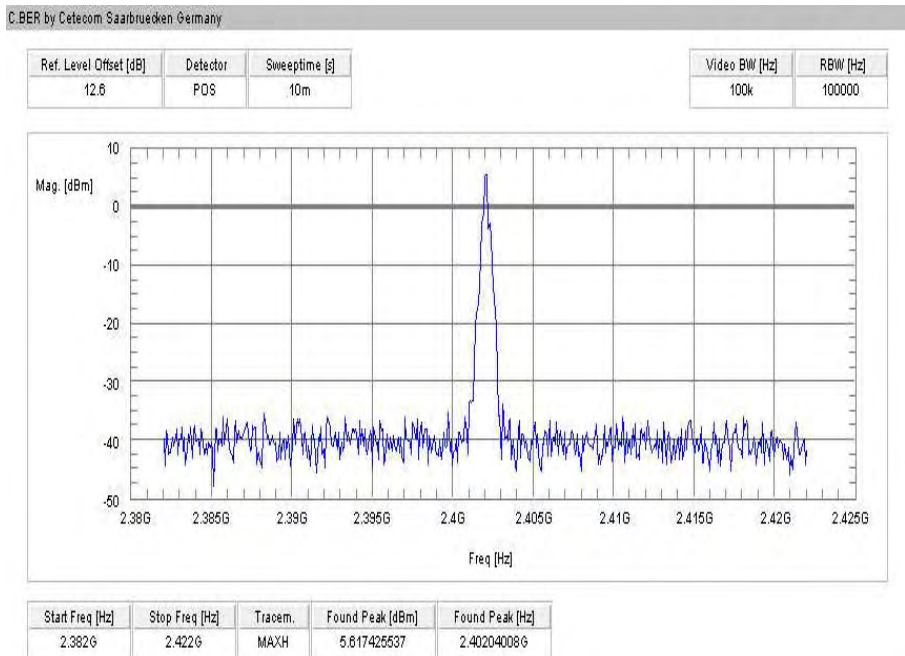

Plot 2: middle channel

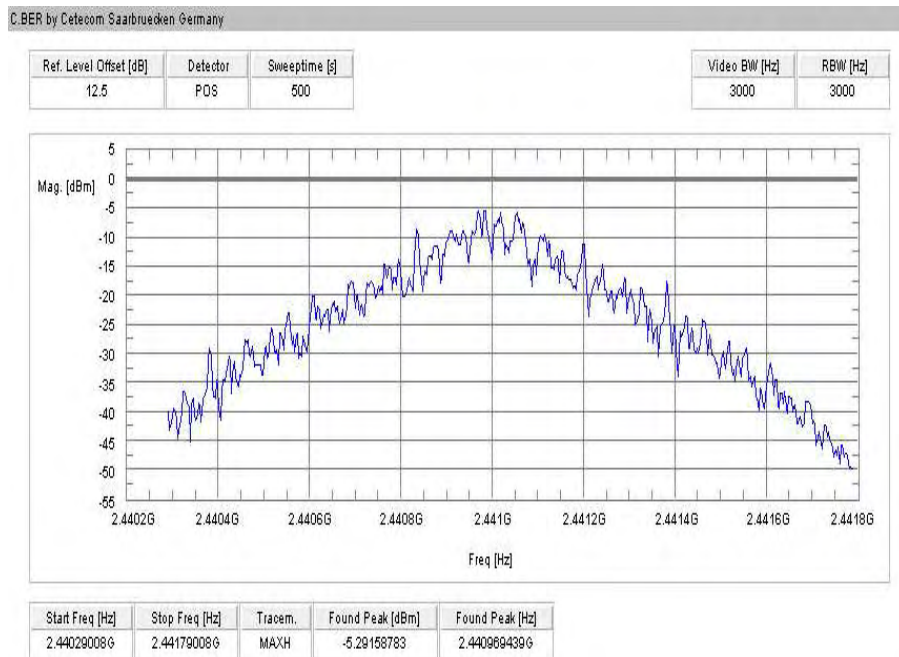
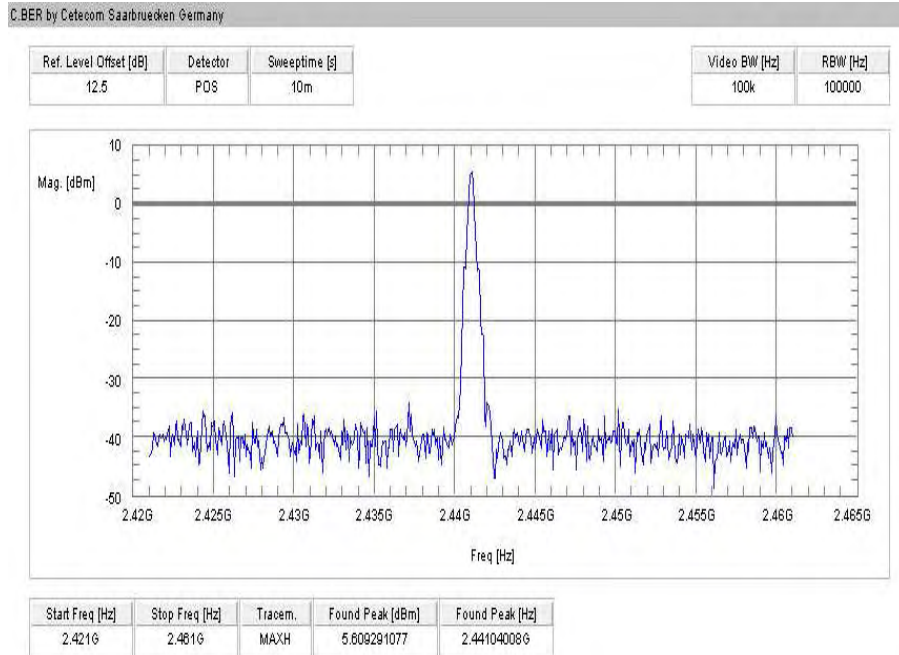

Plot 3: highest channel

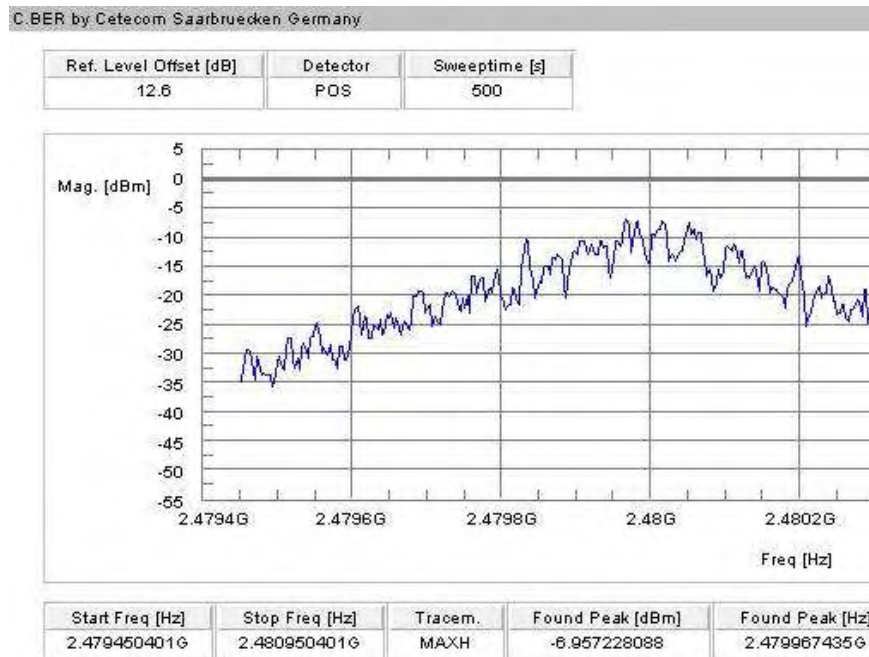
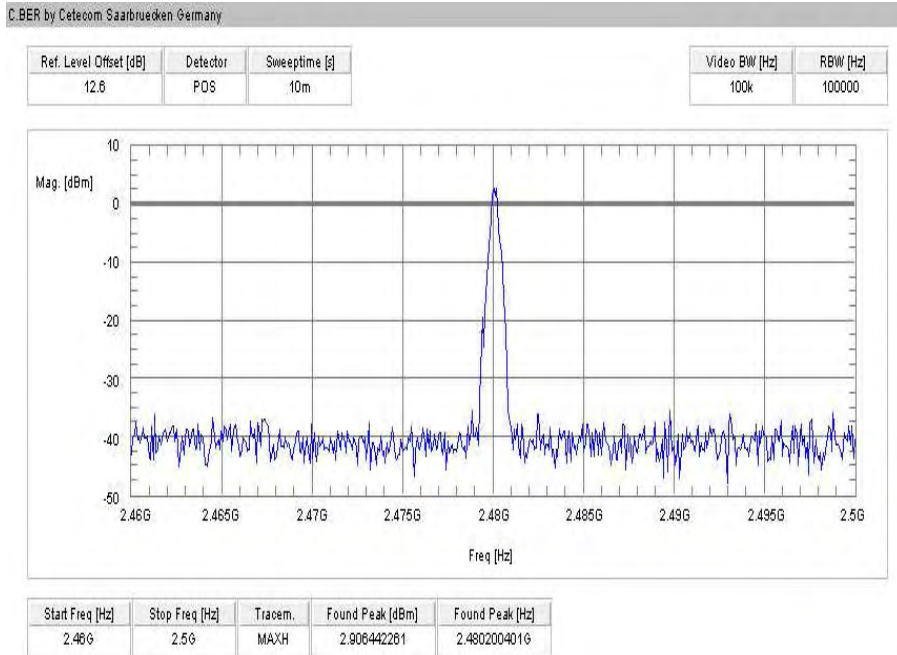

9.4 Spectrum bandwidth of a DSSS system – 6 dB bandwidth

Description:

Measurement of the 6 dB bandwidth of the modulated signal.

Measurement:

Measurement parameter	
Detector:	Peak
Sweep time:	Auto
Video bandwidth:	100 kHz
Resolution bandwidth:	100 kHz
Span:	See plots
Trace-Mode:	Max Hold

Limits:

FCC	IC
CFR Part 15.247 (a)(2)	RSS 210, Issue 8, A 8.2(a)
Spectrum Bandwidth of a DSSS System – 6 dB Bandwidth	
Systems using digital modulation techniques may operate in the 2400–2483.5 MHz band. The minimum 6 dB bandwidth shall be at least 500 kHz.	

Results:

Modulation Frequency	6 dB BANDWIDTH [MHz]		
	2402 MHz	2441 MHz	2480 MHz
DSSS	517	523	517
Measurement uncertainty	± 100 kHz		

Result: The result of the measurement is passed.

Plots: DSSS / ANT+

Plot 1: lowest channel

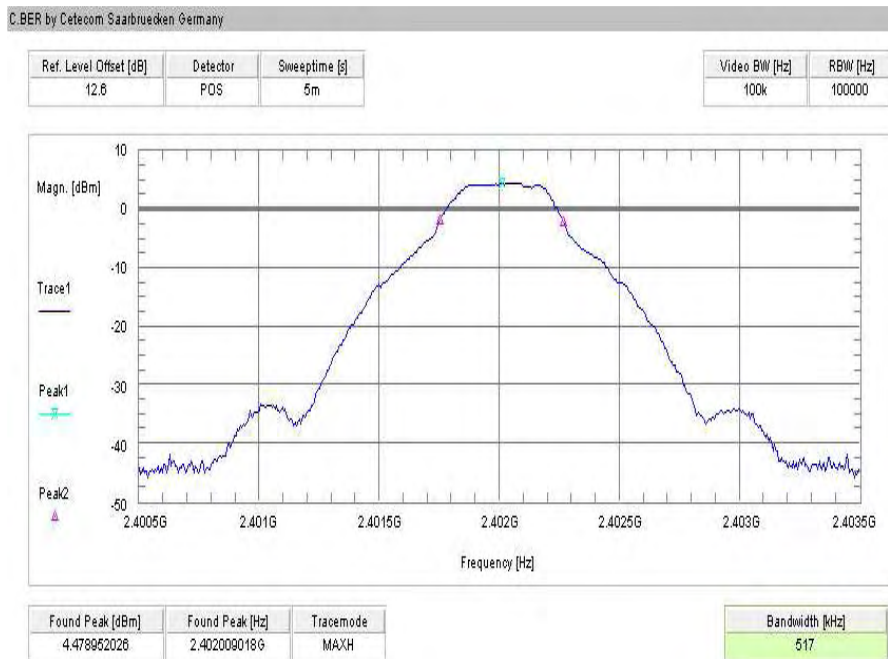

Plot 2: middle channel

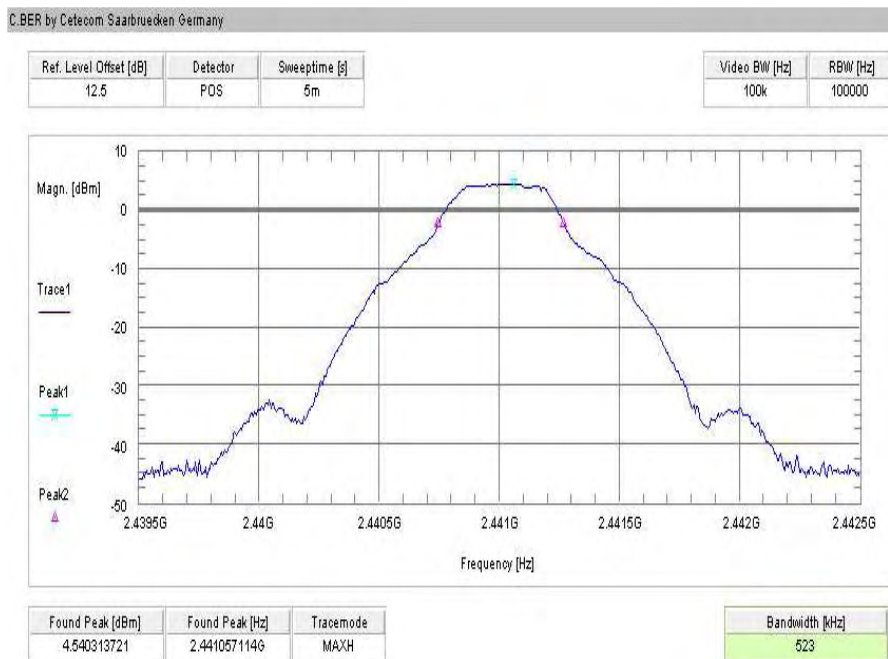

Plot 3: highest channel

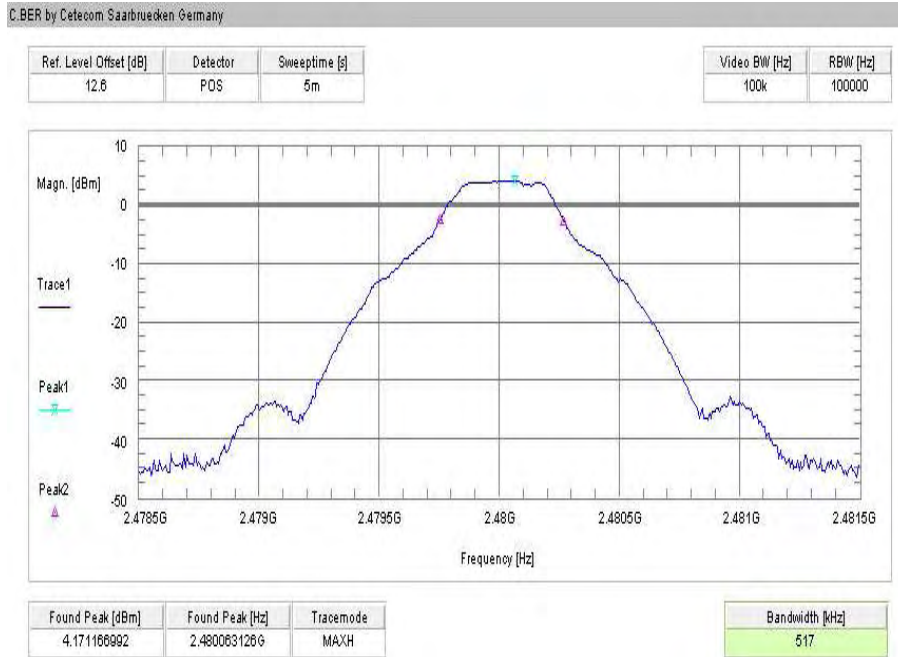

9.5 Spectrum bandwidth of a DSSS system – 20 dB bandwidth

Description:

Measurement of the 20 dB bandwidth of the modulated signal.

Measurement:

Measurement parameter	
Detector:	Peak
Sweep time:	Auto
Video bandwidth:	100 kHz
Resolution bandwidth:	100 kHz
Span:	8 MHz
Trace-Mode:	Max Hold

Limits:

FCC	IC
CFR Part 15.247 (a)(2)	RSS 210, Issue 8, A 8.2(a)
Spectrum Bandwidth of a DSSS System – 20 dB Bandwidth	
Systems using digital modulation techniques may operate in the 2400–2483.5 MHz band. The minimum 6 dB bandwidth shall be at least 500 kHz.	

Results:

Modulation Frequency	20 dB BANDWIDTH [MHz]		
	2402 MHz	2441 MHz	2480 MHz
DSSS	1100	1106	1106
Measurement uncertainty	± 100 kHz		

Result: The result of the measurement is passed.

Plots: DSSS / ANT+

Plot 1: lowest channel

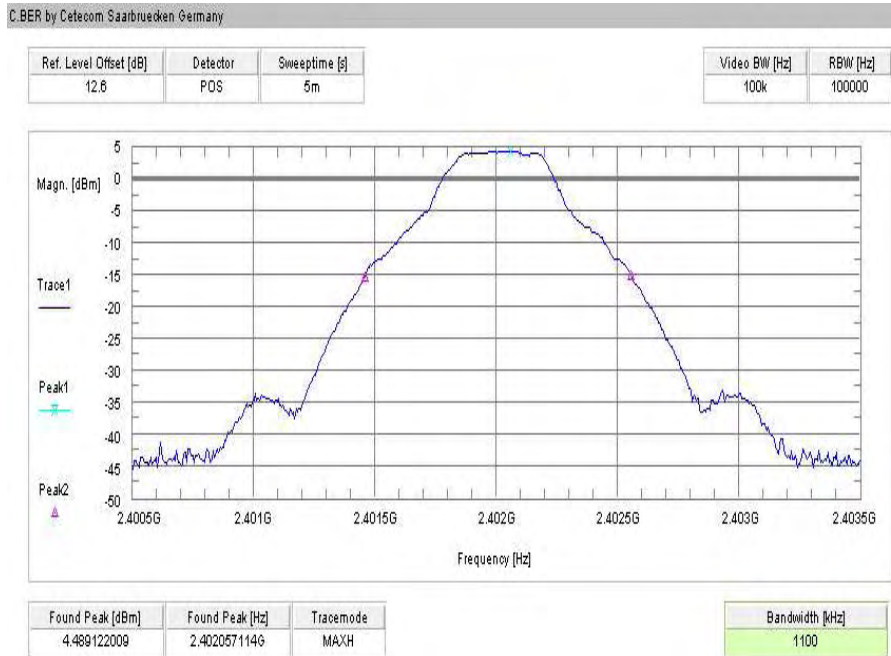

Plot 2: middle channel

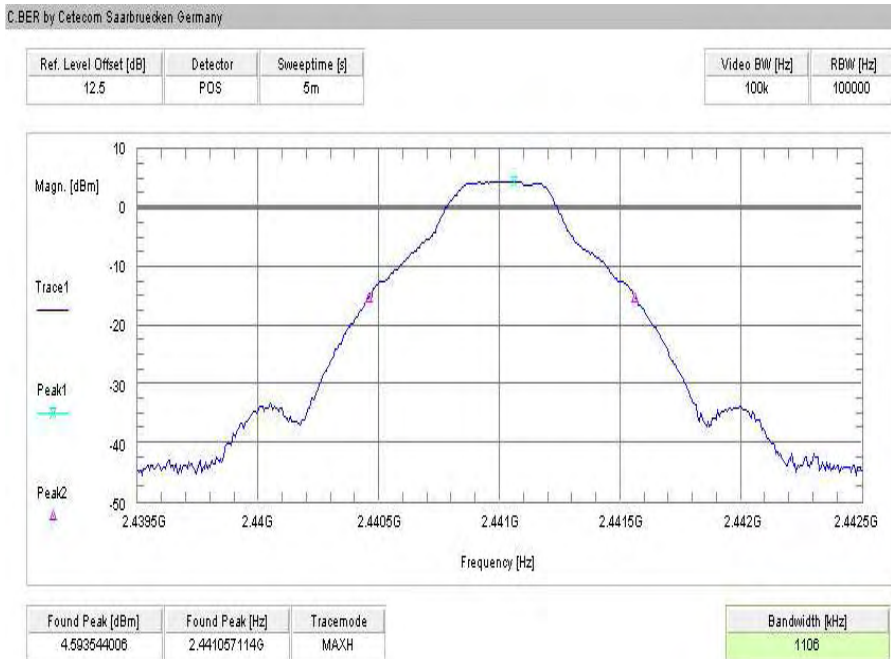

Plot 3: highest channel

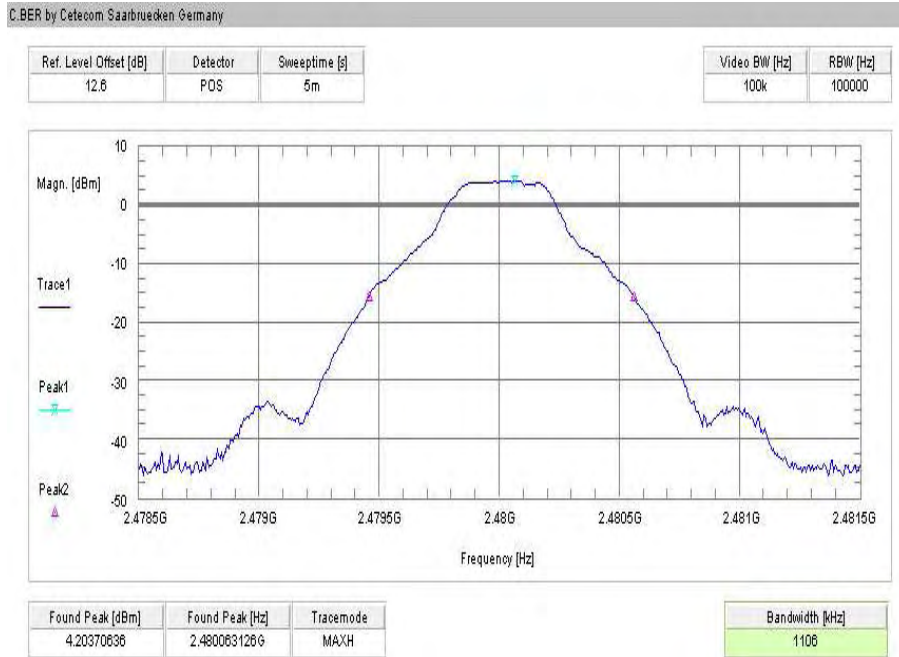

9.6 Band edge compliance conducted

Description:

Measurement of the conducted band edge compliance. EUT is measured at the lower and upper band edge.

Measurement:

Measurement parameter	
Detector:	Peak
Sweep time:	Auto
Video bandwidth:	100 kHz
Resolution bandwidth:	100 kHz
Span:	See plots
Trace-Mode:	Max Hold

Limits:

FCC	IC
CFR Part 15.247 (d)	RSS 210, Issue 8, A 8.5
Band Edge Compliance Conducted	
<p>In any 100 kHz bandwidth outside the frequency band in which the spread spectrum or digitally modulated intentional radiator is operating, the radio frequency power that is produced by the intentional radiator shall be at least 20 dB below that in the 100 kHz bandwidth within the band that contains the highest level of the desired power, based on either an RF conducted or a radiated measurement. Attenuation below the general limits specified in Section 15.209(a) is not required.</p>	

Result:

Szenario Modulation	Band Edge Compliance Conducted [dB]
	DSSS
Lower Band Edge – Channel 00	> 20 dB (see plot 1)
Upper Band Edge – Channel 78	> 20 dB (see plot 2)
Measurement uncertainty	± 1.5 dB

Result: The result of the measurement is passed.

Plots: DSSS / ANT+

Plot 1: lowest channel

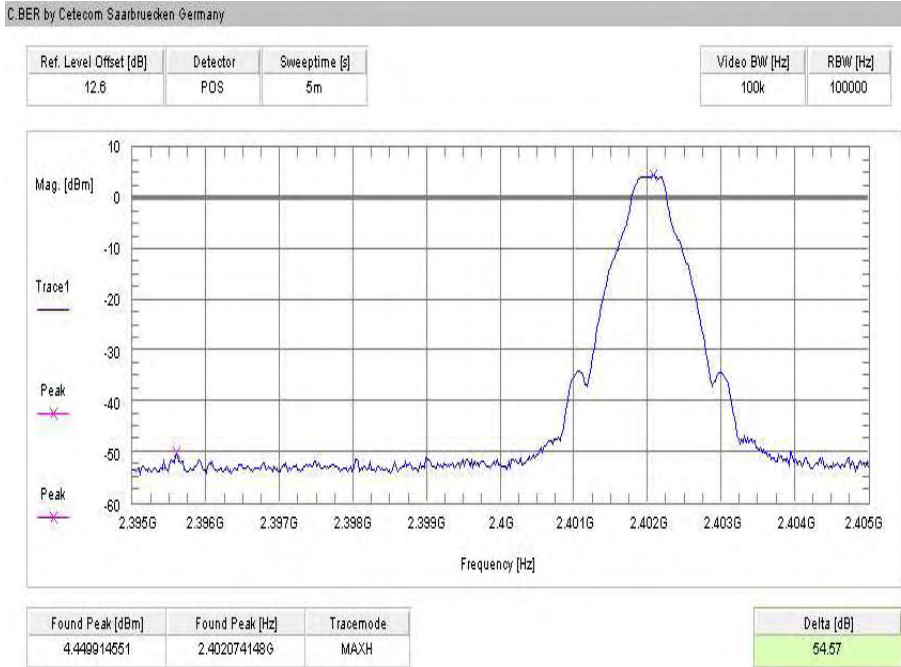

Plot 2: highest channel

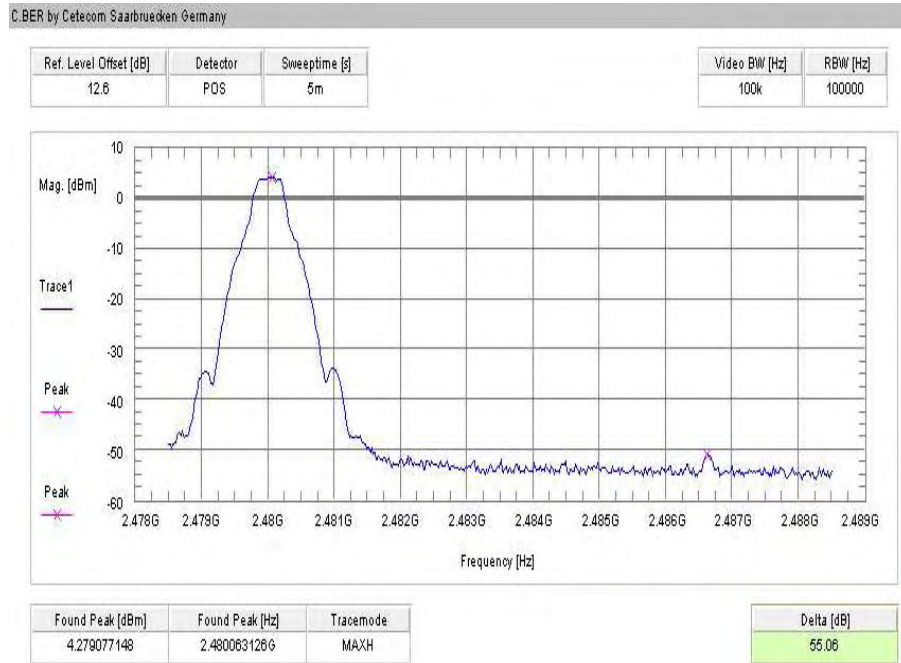

9.7 Band edge compliance radiated

Description:

Measurement of the radiated band edge compliance. The EUT is turned in the position that results in the maximum level at the band edge. Then a sweep over the corresponding restricted band is performed. The EUT is set to channel 00 for the lower restricted band and to channel 78 for the upper restricted band. Measurement distance is 3m.

Measurement:

Measurement parameter	
Detector:	Peak
Sweep time:	Auto
Video bandwidth:	10 Hz
Resolution bandwidth:	1 MHz
Span:	Lower Band: 2300 – 2400 MHz Higher Band: 2480 – 2500 MHz
Trace-Mode:	Max Hold

Limits:

FCC	IC
CFR Part 15.205	RSS 210, Issue 8, A 8.5
Band Edge Compliance Radiated	
<p>In any 100 kHz bandwidth outside the frequency band in which the spread spectrum or digitally modulated intentional radiator is operating, the radio frequency power that is produced by the intentional radiator shall be at least 20 dB below that in the 100 kHz bandwidth within the band that contains the highest level of the desired power, based on either an RF conducted or a radiated measurement. Attenuation below the general limits specified in Section 15.209(a) is not required. In addition, radiated emissions which fall in the restricted bands, as defined in Section 15.205(a), must also comply with the radiated emission limits specified in Section 15.209(a) (see Section 5.205(c)).</p>	
54 dB μ V/m AVG	

Result:

Szenario	Band Edge Compliance Radiated [dB μ V/m]
Modulation	DSSS
Lower Band Edge – Channel 00	< 54 dB μ V/m (see plots 1/3)
Upper Band Edge – Channel 78	< 54 dB μ V/m (see plot 2/4)
Measurement uncertainty	\pm 3 dB

Plots: DSSS / ANT+

Plot 1: lower band edge, vertical polarization (worst case)

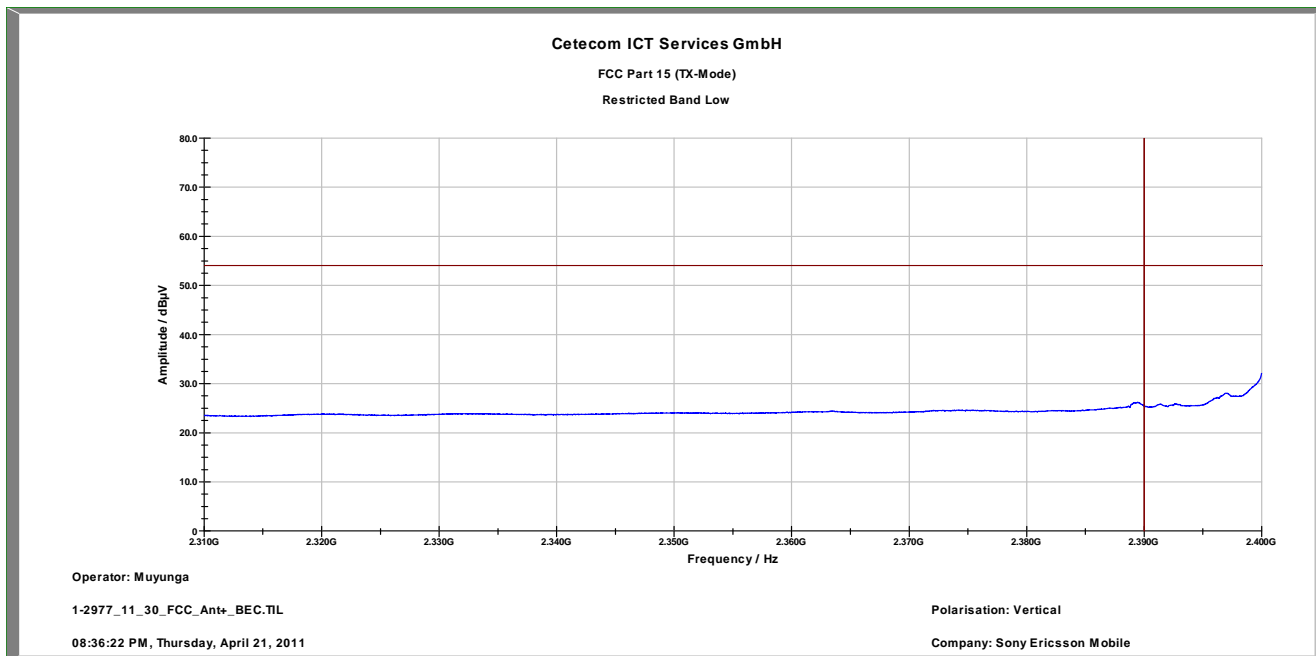

Plot 2: upper band edge, vertical polarization (worst case)

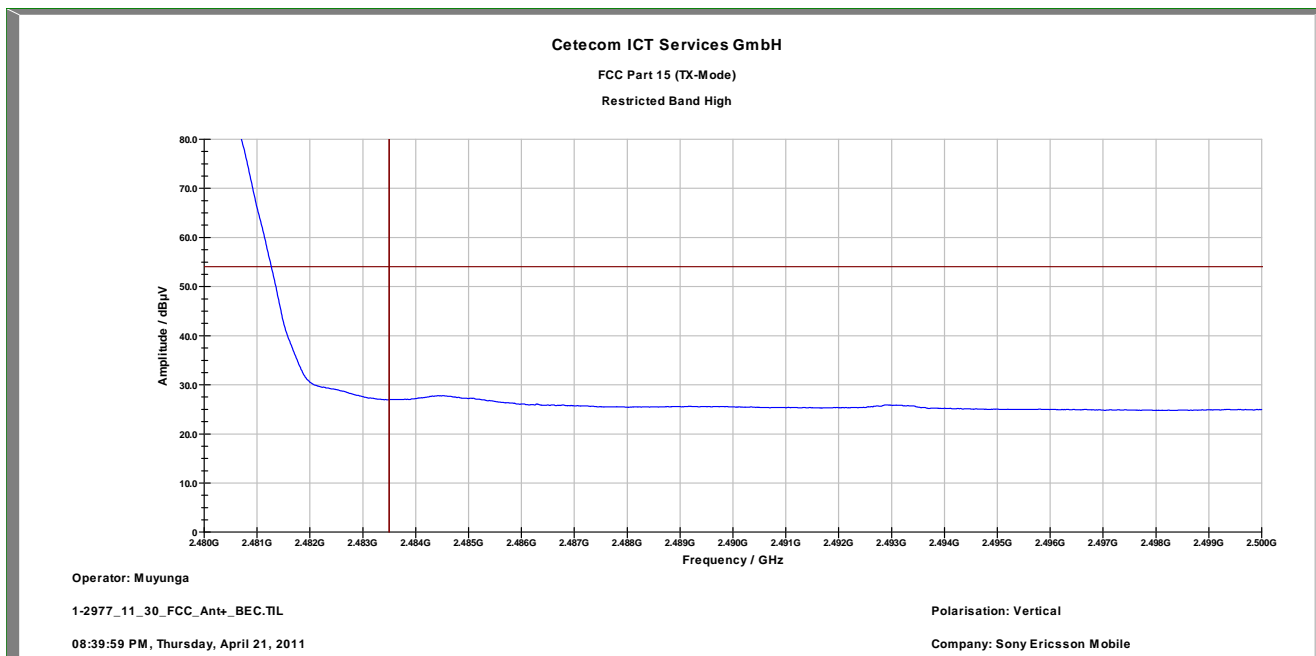

Result: The result of the measurement is passed.

9.8 TX spurious emissions conducted

Description:

Measurement of the conducted spurious emissions in transmit mode. The measurement is performed at lowest, middle and highest channel.

Measurement:

Measurement parameter	
Detector:	Peak
Sweep time:	Auto
Video bandwidth:	F < 1 GHz: 100 kHz F > 1 GHz: 100 kHz
Resolution bandwidth:	F < 1 GHz: 100 kHz F > 1 GHz: 100 kHz
Span:	9 kHz to 25 GHz
Trace-Mode:	Max Hold

Limits:

FCC	IC
CFR Part 15.247(d)	RSS 210, Issue 8, A 8.5
TX Spurious Emissions Conducted	
<p>In any 100 kHz bandwidth outside the frequency band in which the spread spectrum or digitally modulated intentional radiator is operating, the radio frequency power that is produced by the intentional radiator shall be at least 20 dB below that in the 100 kHz bandwidth within the band that contains the highest level of the desired power, based on either an RF conducted or a radiated measurement. Attenuation below the general limits specified in Section 15.209(a) is not required</p>	

Results: DSSS / ANT+

TX Spurious Emissions Conducted					
DSSS - mode					
f [MHz]		amplitude of emission [dBm]	limit max. allowed emission power	actual attenuation below frequency of operation [dB]	results
2402		4.6	30 dBm		Operating frequency
<i>No critical peaks found</i>			-20 dBc		complies
2441		4.9	30 dBm		Operating frequency
<i>No critical peaks found</i>			-20 dBc		complies
2480		4.3	30 dBm		Operating frequency
<i>No critical peaks found</i>			-20 dBc		complies
Measurement uncertainty			± 3 dB		

Result: The result of the measurement is passed.

Plots: DSSS / ANT+

Plot 1: lowest channel

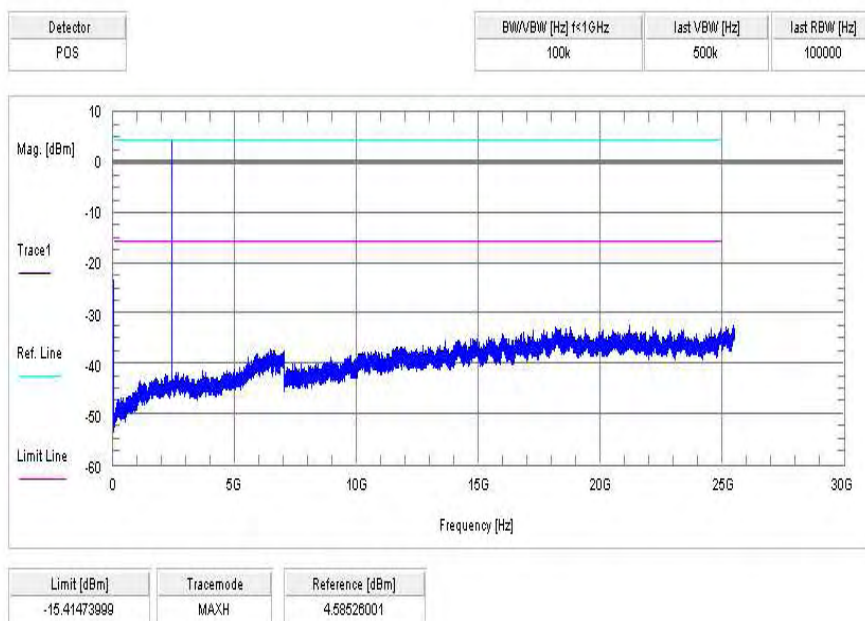

Plot 2: middle channel

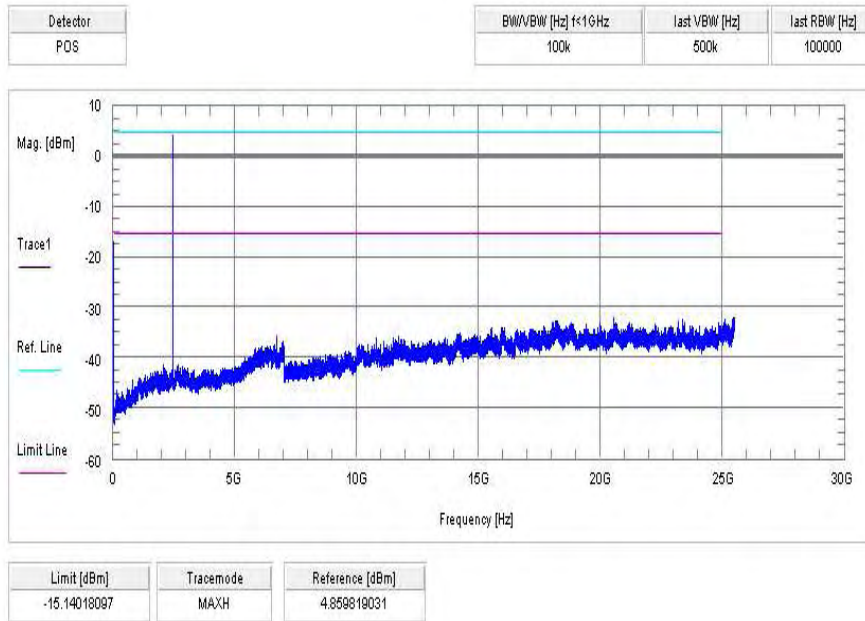

Plot 3: highest channel

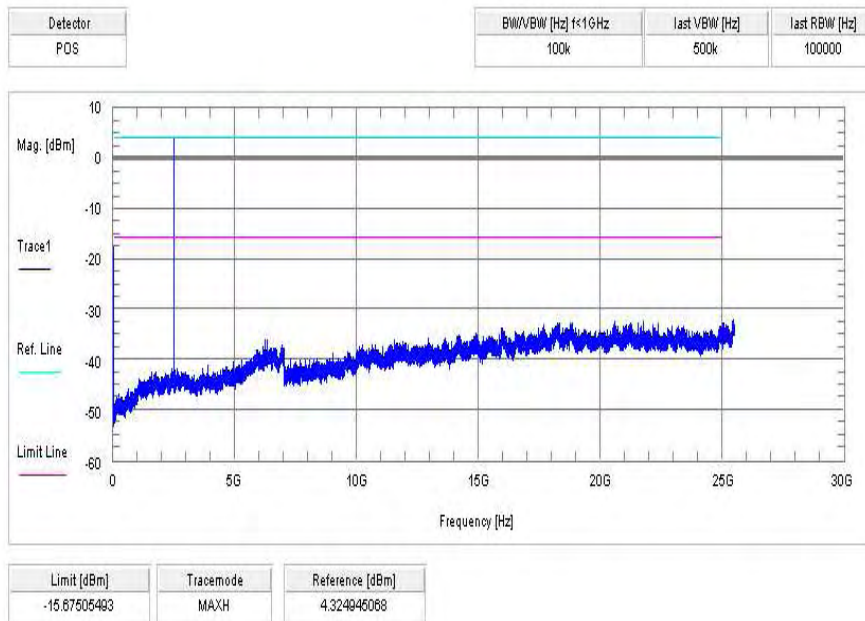

9.9 TX spurious emissions radiated

Description:

Measurement of the radiated spurious emissions in transmit mode. The measurement is performed at lowest, middle and highest channel.

Measurement:

Measurement parameter	
Detector:	Peak / Quasi Peak
Sweep time:	Auto
Video bandwidth:	Sweep: 100 kHz Remeasurement: 10 Hz
Resolution bandwidth:	F < 1 GHz: 100 kHz F > 1 GHz: 1 MHz
Span:	30 MHz to 25 GHz
Trace-Mode:	Max Hold
Measured Modulation	<input checked="" type="checkbox"/> DSSS

Limits:

FCC		IC	
CFR Part 15.247(d)		RSS 210, Issue 8, A 8.5	
TX Spurious Emissions Radiated			
<p>In any 100 kHz bandwidth outside the frequency band in which the spread spectrum or digitally modulated intentional radiator is operating, the radio frequency power that is produced by the intentional radiator shall be at least 20 dB below that in the 100 kHz bandwidth within the band that contains the highest level of the desired power, based on either an RF conducted or a radiated measurement. Attenuation below the general limits specified in Section 15.209(a) is not required. In addition, radiated emissions which fall in the restricted bands, as defined in §15.205(a), must also comply with the radiated emission limits specified in §15.209(a) (see §15.205(c)).</p>			
§15.209			
Frequency (MHz)	Field Strength (dBµV/m)	Measurement distance	
30 - 88	30.0	10	
88 – 216	33.5	10	
216 – 960	36.0	10	
Above 960	54.0	3	

Results: DSSS / ANT+ – mode

TX Spurious Emissions Radiated [dB μ V/m]								
DSSS – mode								
2402 MHz			2441 MHz			2480 MHz		
F [MHz]	Detector	Level [dB μ V/m]	F [MHz]	Detector	Level [dB μ V/m]	F [MHz]	Detector	Level [dB μ V/m]
No critical peaks found			No critical peaks found			No critical peaks found		
Measurement uncertainty			± 3 dB					

Result: The result of the measurement is passed.

Plots: DSSS / ANT+

Plot 1: Lowest channel, 30 MHz to 1 GHz, vertical & horizontal polarization

CETECOM ICT Services GmbH

Common Information

EUT: AAD-3880112-BV
 Serial Number: CB5A1CH5QV IMEI: 00440214-249968-4
 Test Description: FCC part 15 class B @ 10 m
 Operating Conditions: ANT+ TX Ch. 0 + charging
 Operator Name: Hennemann
 Comment: AC: 115 V / 60 Hz

Scan Setup: STAN_Fin [EMI radiated]

Hardware Setup: Electric Field (NOS)
 Level Unit: dBµV/m
Subrange **Detectors** **IF Bandwidth** **Meas. Time** **Receiver**
 30 MHz - 2 GHz QuasiPeak 120 kHz 15 s Receiver

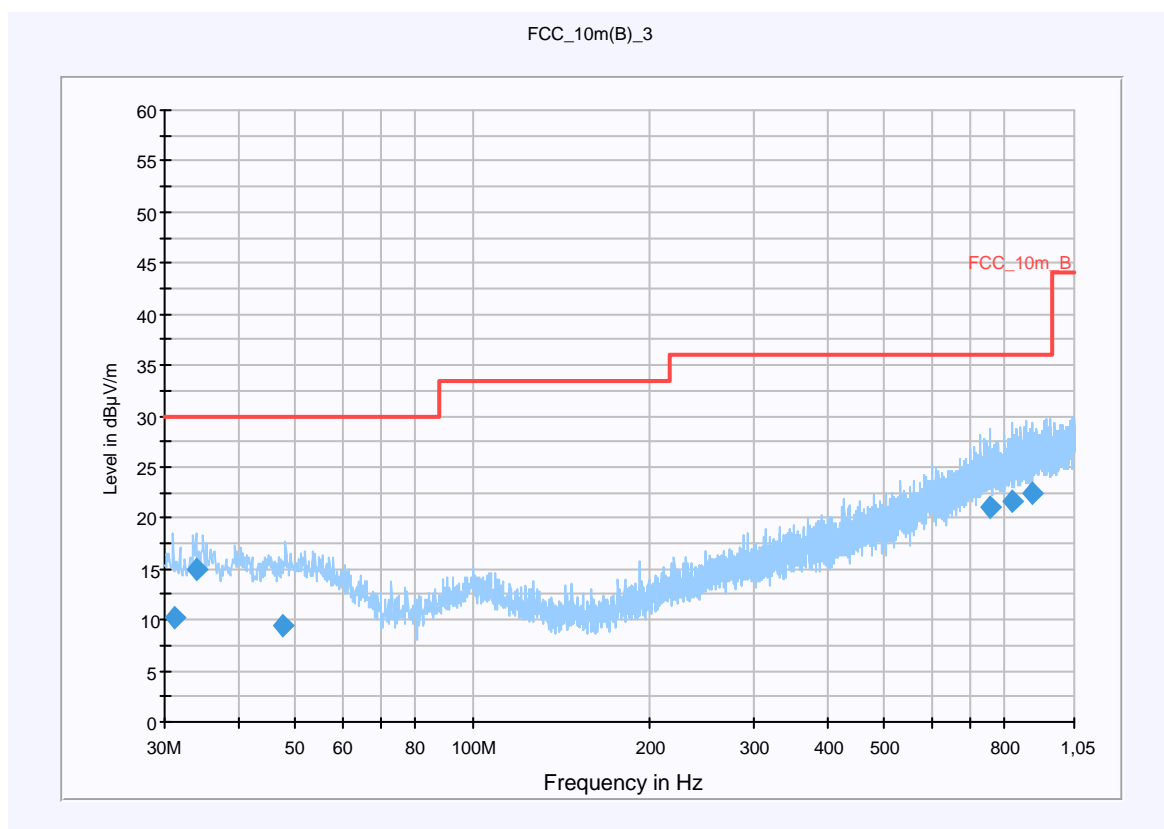

Final Result 1

Frequency (MHz)	QuasiPeak (dBµV/m)	Meas. Time (ms)	Bandwidth (kHz)	Antenna height (cm)	Polarity	Turntable position (deg)	Corr. (dB)	Margin (dB)	Limit (dBµV/m)	Comment
31.178700	10.2	15000.000	120.000	220.0	H	146.0	12.6	19.8	30.0	
33.980550	14.9	15000.000	120.000	220.0	V	324.0	12.9	15.1	30.0	
47.561550	9.4	15000.000	120.000	168.0	H	146.0	13.3	20.6	30.0	
754.100250	21.0	15000.000	120.000	220.0	V	52.0	23.7	15.0	36.0	
826.070850	21.6	15000.000	120.000	98.0	V	166.0	24.2	14.4	36.0	
889.405350	22.5	15000.000	120.000	120.0	H	146.0	25.1	13.5	36.0	

Plot 2: Lowest channel, 1 GHz to 12.75 GHz, vertical polarization

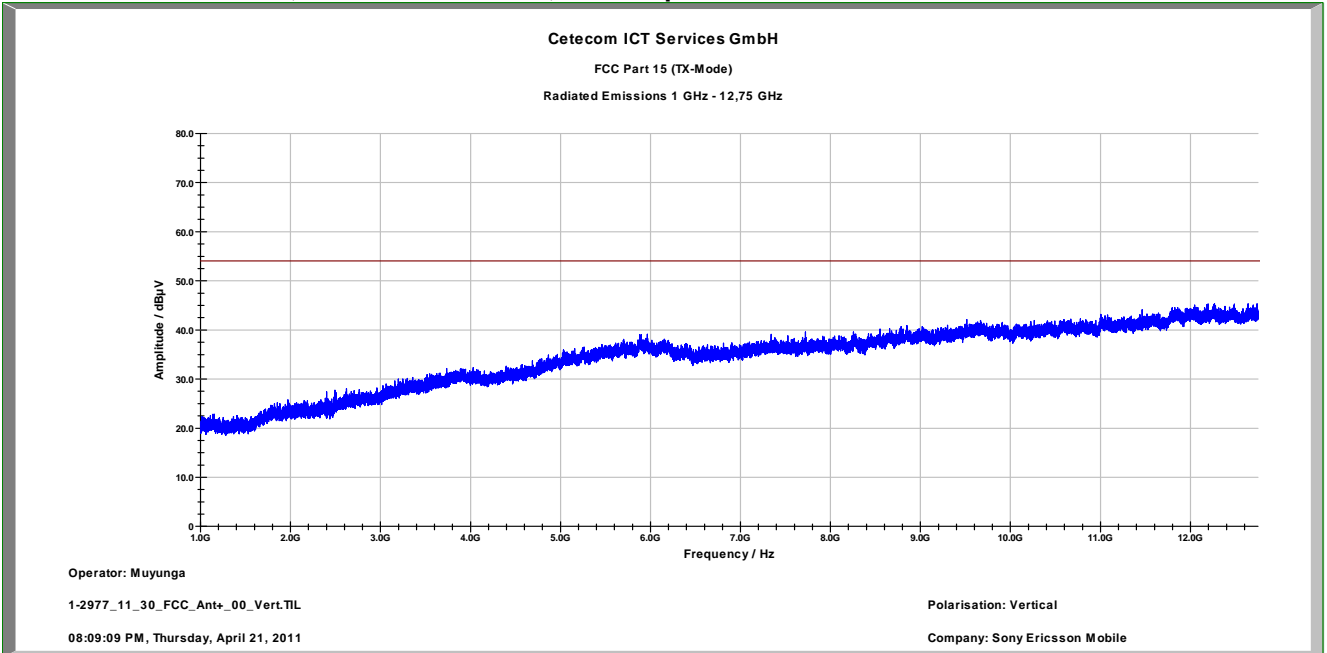

The carrier signal is notched with a 2.4 GHz band rejection filter.

Plot 3: Lowest channel, 1 GHz to 12.75 GHz, horizontal polarization

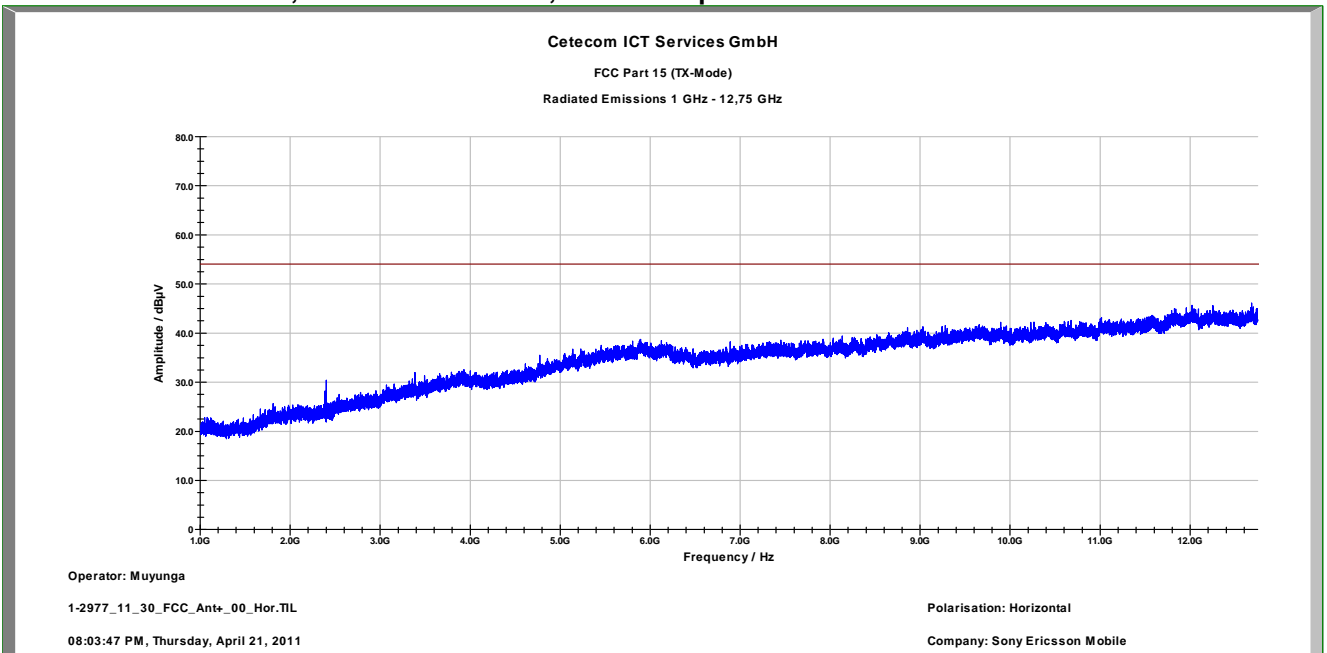

The carrier signal is notched with a 2.4 GHz band rejection filter.

Plot 4: Lowest channel, 12 GHz to 25 GHz (valid for all channels)



Plot 5: Middle channel, 30 MHz to 1 GHz, vertical & horizontal polarization

CETECOM ICT Services GmbH

Common Information

EUT: AAD-3880112-BV
 Serial Number: CB5A1CH5QV IMEI: 00440214-249968-4
 Test Description: FCC part 15 class B @ 10 m
 Operating Conditions: ANT+ TX Ch. 39 + charging
 Operator Name: Hennemann
 Comment: AC: 115 V / 60 Hz

Scan Setup: STAN_Fin [EMI radiated]

Hardware Setup: Electric Field (NOS)
 Level Unit: dBµV/m
Subrange **Detectors** **IF Bandwidth** **Meas. Time** **Receiver**
 30 MHz - 2 GHz QuasiPeak 120 kHz 15 s Receiver

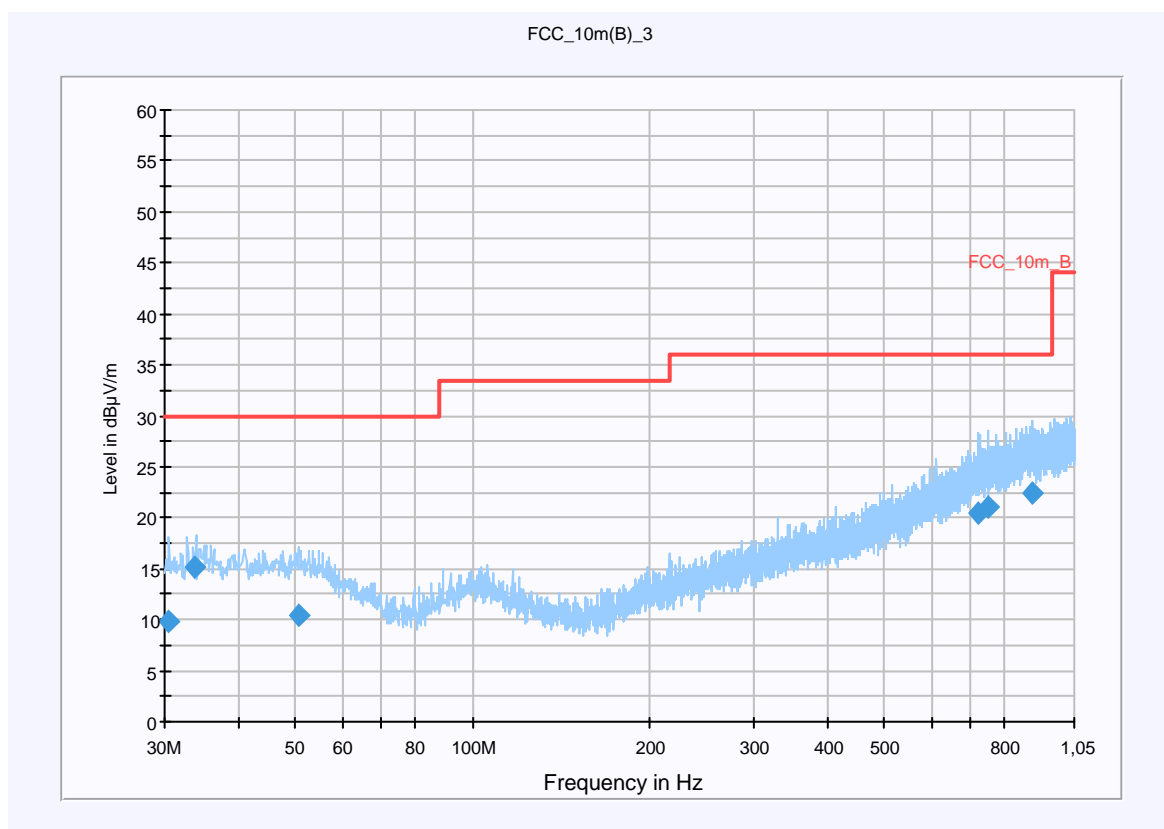

Final Result 1

Frequency (MHz)	QuasiPeak (dBµV/m)	Meas. Time (ms)	Bandwidth (kHz)	Antenna height (cm)	Polarity	Turntable position (deg)	Corr. (dB)	Margin (dB)	Limit (dBµV/m)	Comment
30.418609	9.8	15000.000	120.000	220.0	H	159.0	12.5	20.2	30.0	
33.628050	15.2	15000.000	120.000	220.0	V	142.0	12.9	14.8	30.0	
50.856600	10.3	15000.000	120.000	98.0	H	52.0	13.3	19.7	30.0	
723.392700	20.4	15000.000	120.000	106.0	H	324.0	23.0	15.6	36.0	
748.576800	21.1	15000.000	120.000	220.0	V	165.0	23.6	14.9	36.0	
891.843150	22.4	15000.000	120.000	220.0	V	22.0	25.1	13.6	36.0	

Plot 6: Middle channel, 1 GHz to 12.75 GHz, vertical polarization

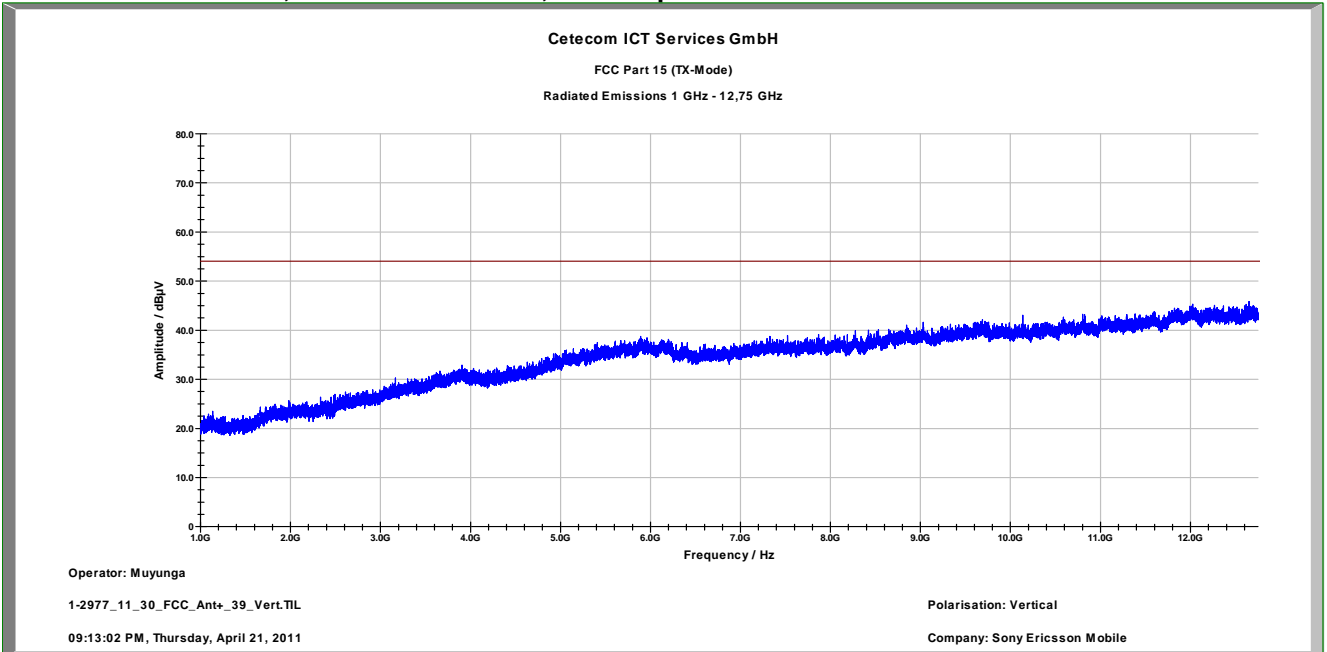

The carrier signal is notched with a 2.4 GHz band rejection filter.

Plot 7: Middle channel, 1 GHz to 12.75 GHz, horizontal polarization

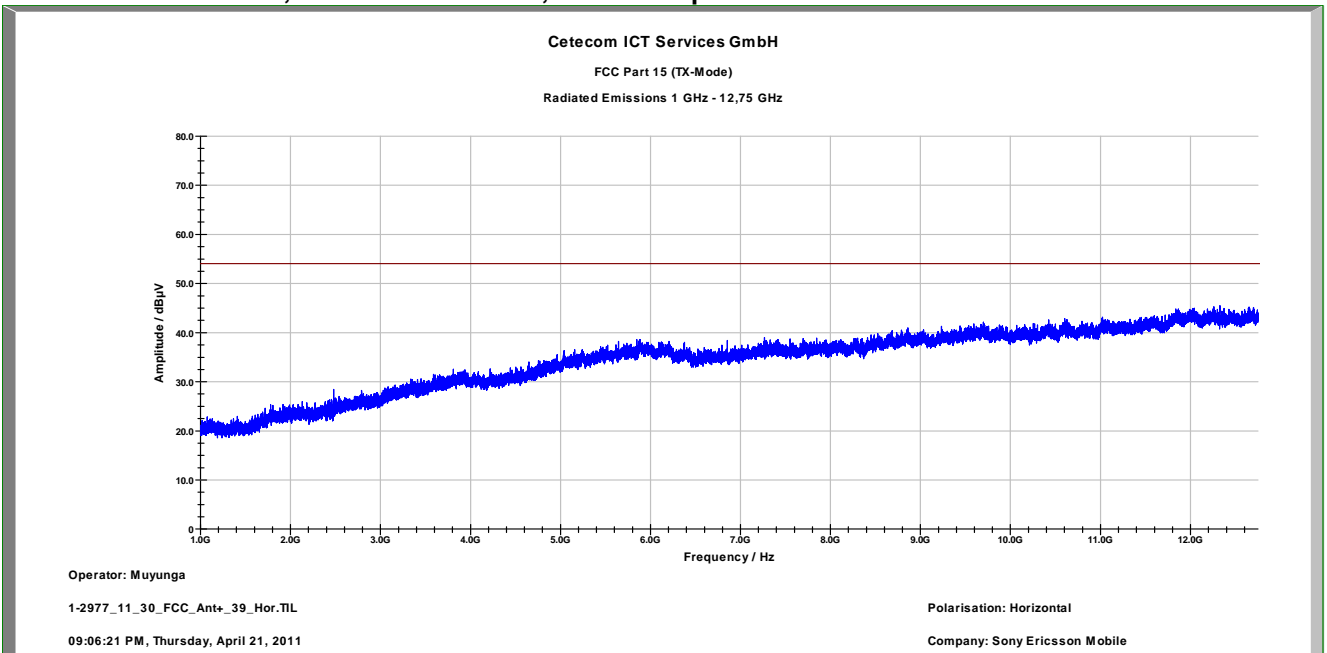

The carrier signal is notched with a 2.4 GHz band rejection filter.

Plot 8: Highest channel, 30 MHz to 1 GHz, vertical & horizontal polarization

CETECOM ICT Services GmbH

Common Information

EUT: AAD-3880112-BV
 Serial Number: CB5A1CH5QV IMEI: 00440214-249968-4
 Test Description: FCC part 15 class B @ 10 m
 Operating Conditions: ANT + TX Ch. 78 + charging
 Operator Name: Hennemann
 Comment: AC: 115 V / 60 Hz

Scan Setup: STAN_Fin [EMI radiated]

Hardware Setup: Electric Field (NOS)
 Level Unit: dBµV/m
Subrange **Detectors** **IF Bandwidth** **Meas. Time** **Receiver**
 30 MHz - 2 GHz QuasiPeak 120 kHz 15 s Receiver

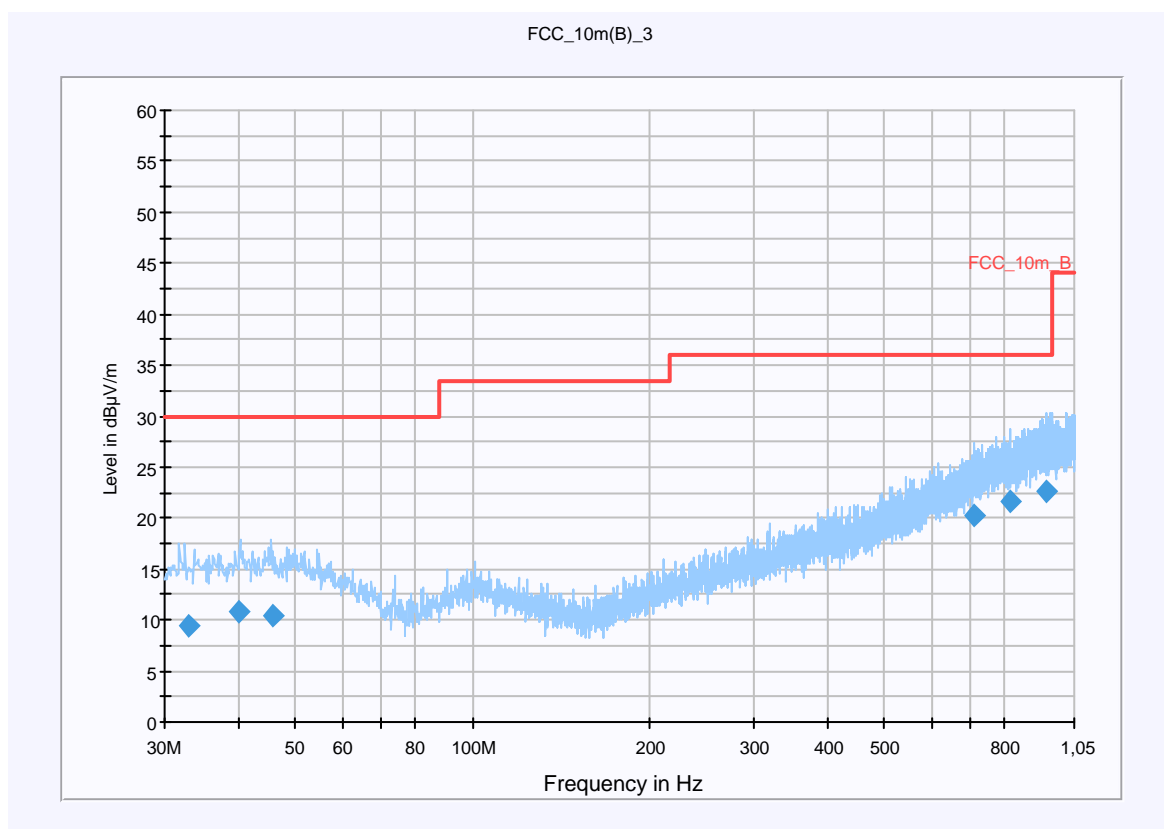

Final Result 1

Frequency (MHz)	QuasiPeak (dBµV/m)	Meas. Time (ms)	Bandwidth (kHz)	Antenna height (cm)	Polarity	Turntable position (deg)	Corr. (dB)	Margin (dB)	Limit (dBµV/m)	Comment
33.030750	9.5	15000.000	120.000	199.0	V	51.0	12.8	20.5	30.0	
39.940800	10.7	15000.000	120.000	214.0	V	324.0	13.4	19.3	30.0	
45.831300	10.4	15000.000	120.000	178.0	H	268.0	13.3	19.6	30.0	
711.222600	20.3	15000.000	120.000	98.0	V	29.0	22.8	15.7	36.0	
819.966450	21.6	15000.000	120.000	148.0	H	11.0	24.1	14.4	36.0	
943.816650	22.6	15000.000	120.000	120.0	H	5.0	25.3	13.4	36.0	

Plot 9: Highest channel, 1 GHz to 12.75 GHz, vertical polarization

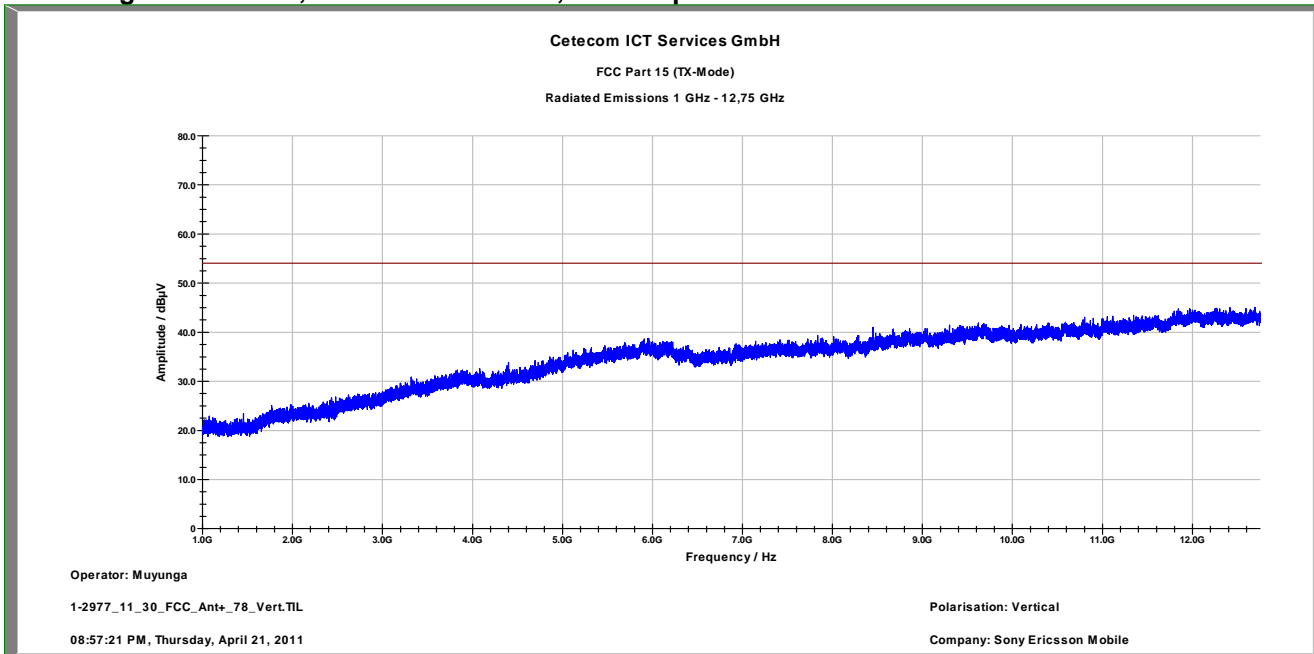

The carrier signal is notched with a 2.4 GHz band rejection filter.

Plot 10: Highest channel, 1 GHz to 12.75 GHz, horizontal polarization

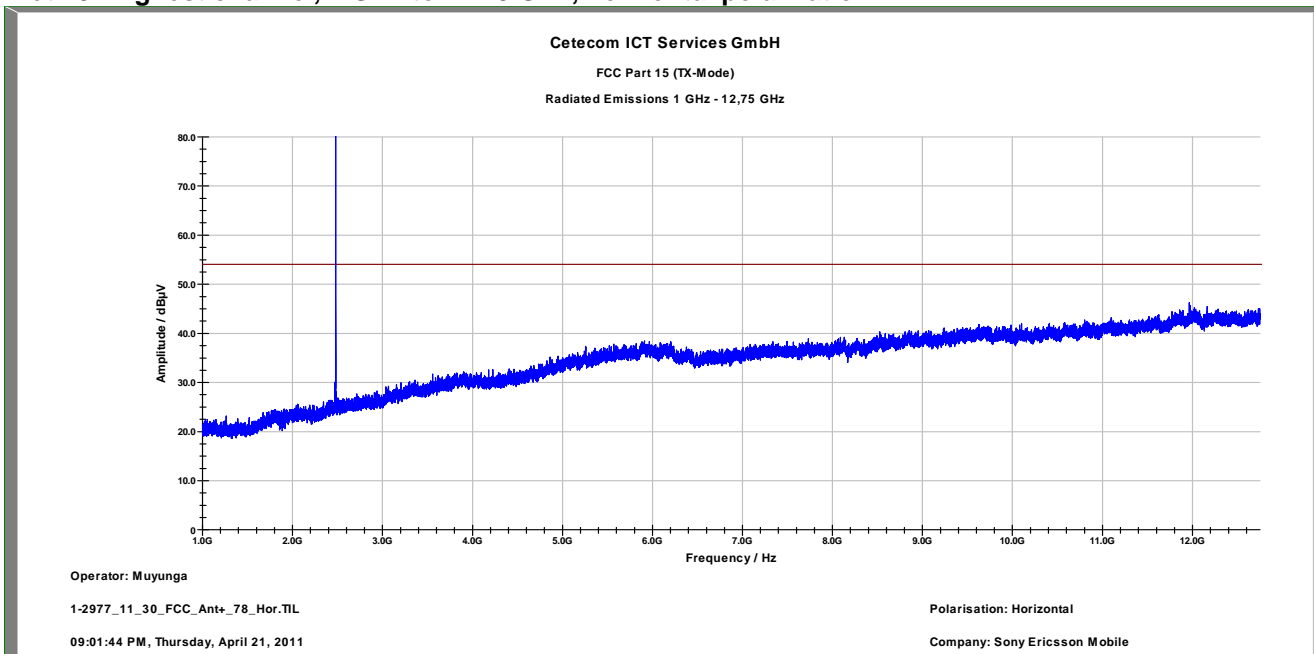

The carrier signal is not notched with a 2.4 GHz band rejection filter.

9.10 RX spurious emissions radiated

Description:

Measurement of the radiated spurious emissions in idle/receive mode.

Measurement:

Measurement parameter	
Detector:	Peak / Quasi Peak
Sweep time:	Auto
Video bandwidth:	Sweep: 100 kHz Remeasurement: 10 Hz
Resolution bandwidth:	F < 1 GHz: 100 kHz F > 1 GHz: 1 MHz
Span:	30 MHz to 25 GHz
Trace-Mode:	Max Hold

Limits:

FCC		IC
CFR Part 15.109		RSS Gen, Issue 2, 4.10
RX Spurious Emissions Radiated		
Frequency (MHz)	Field Strength (dB μ V/m)	Measurement distance
30 - 88	30.0	10
88 – 216	33.5	10
216 – 960	36.0	10
Above 960	54.0	3

Results:

RX Spurious Emissions Radiated [dB μ V/m]		
F [MHz]	Detector	Level [dB μ V/m]
No critical peaks found		
Measurement uncertainty	± 3 dB	

Result: The result of the measurement is passed.

Plots: RX / Idle – mode

Plot 1: 30 MHz to 1 GHz, vertical & horizontal polarization

CETECOM ICT Services GmbH

Common Information

EUT: AAD-3880112-BV
 Serial Number: CB5A1CH5QV IMEI: 00440214-249968-4
 Test Description: FCC part 15 class B @ 10 m
 Operating Conditions: ANT+ RX + charging
 Operator Name: Hennemann
 Comment: AC: 115 V / 60 Hz

Scan Setup: STAN_Fin [EMI radiated]

Hardware Setup: Electric Field (NOS)
 Level Unit: dBµV/m
Subrange **Detectors** **IF Bandwidth** **Meas. Time** **Receiver**
 30 MHz - 2 GHz QuasiPeak 120 kHz 15 s Receiver

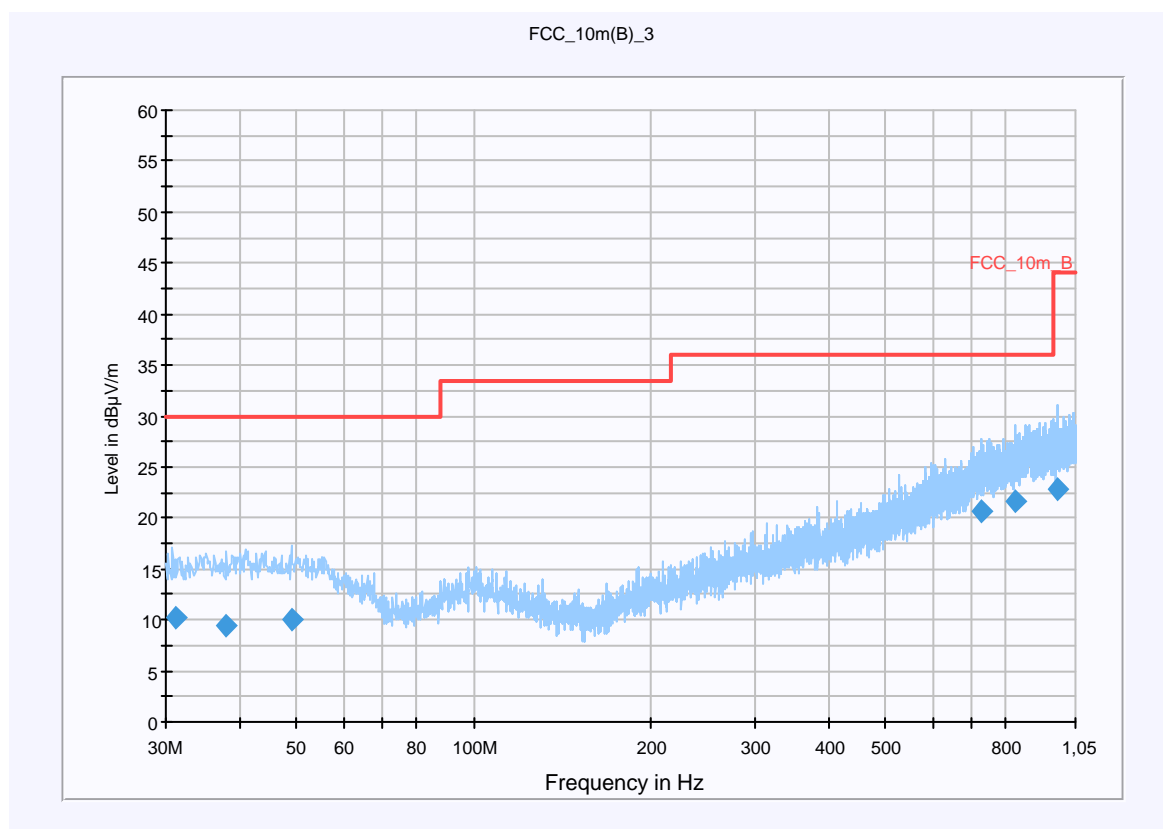

Final Result 1

Frequency (MHz)	QuasiPeak (dBµV/m)	Meas. Time (ms)	Bandwidth (kHz)	Antenna height (cm)	Polarity	Turntable position (deg)	Corr. (dB)	Margin (dB)	Limit (dBµV/m)	Comment
31.229550	10.3	15000.000	120.000	98.0	H	48.0	12.6	19.7	30.0	
37.852950	9.5	15000.000	120.000	220.0	V	48.0	13.3	20.5	30.0	
49.227000	10.0	15000.000	120.000	135.0	H	30.0	13.4	20.0	30.0	
728.363700	20.7	15000.000	120.000	209.0	V	222.0	23.2	15.3	36.0	
826.917000	21.7	15000.000	120.000	220.0	H	155.0	24.2	14.3	36.0	
976.451850	22.9	15000.000	120.000	220.0	H	7.0	25.6	21.1	44.0	

Plot 2: 1 GHz to 12.75 GHz, vertical polarization

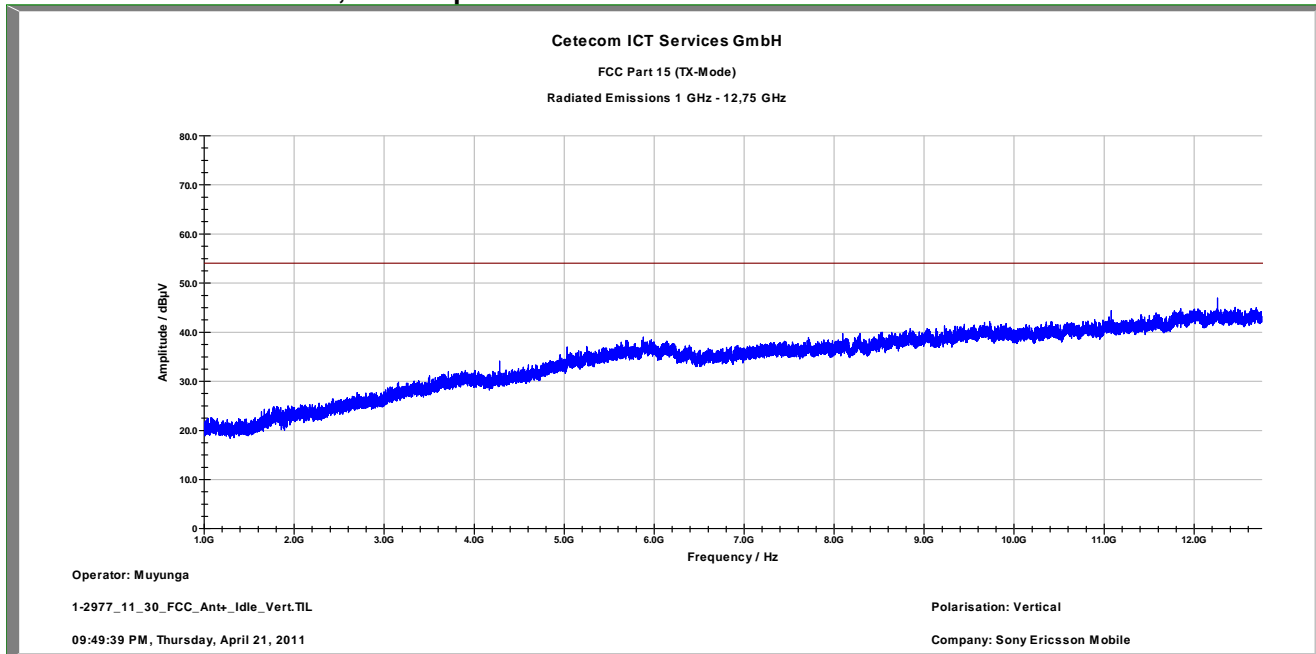

Plot 3: 1 GHz to 12.75 GHz, horizontal polarization

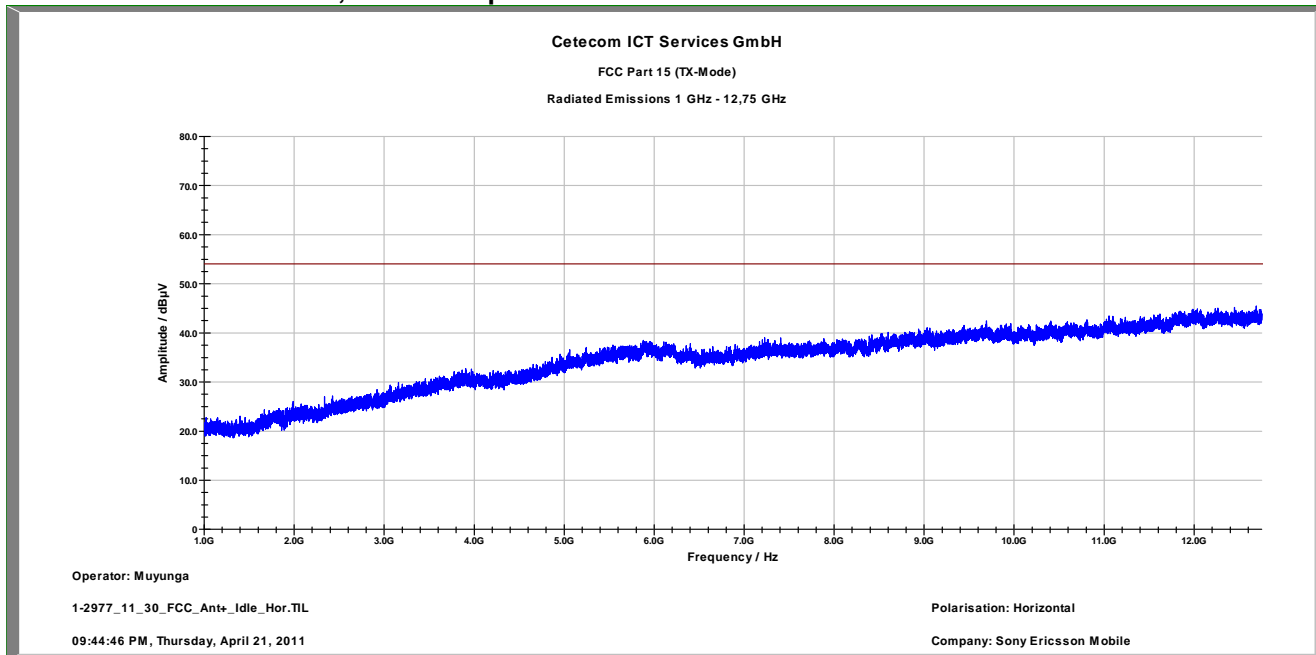

Plot 4: 12 GHz to 25 GHz

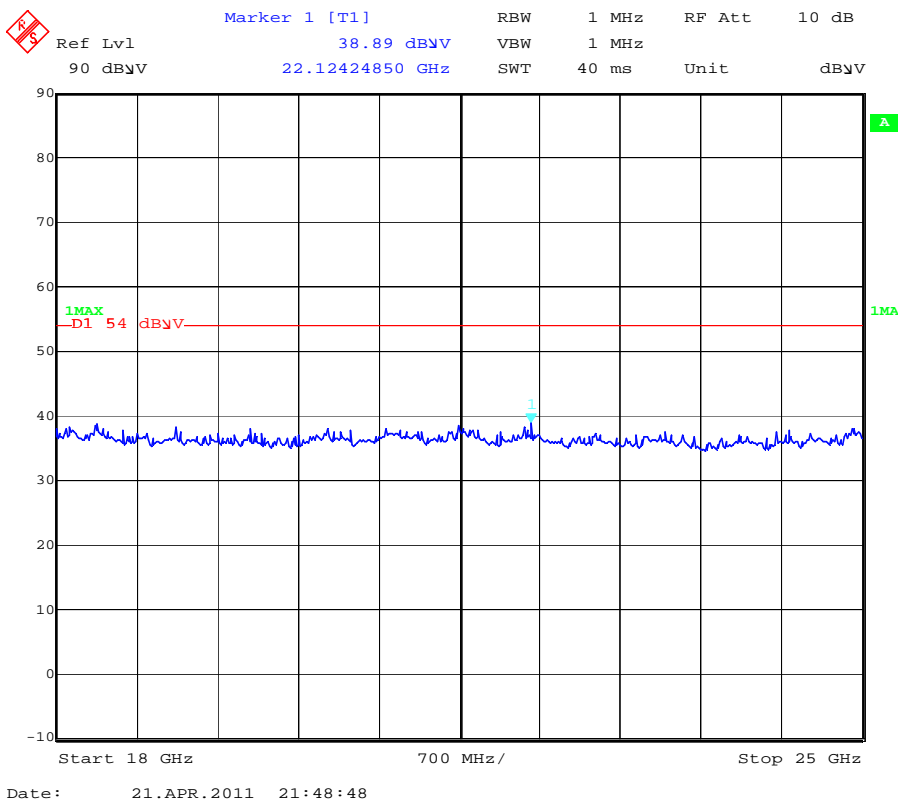
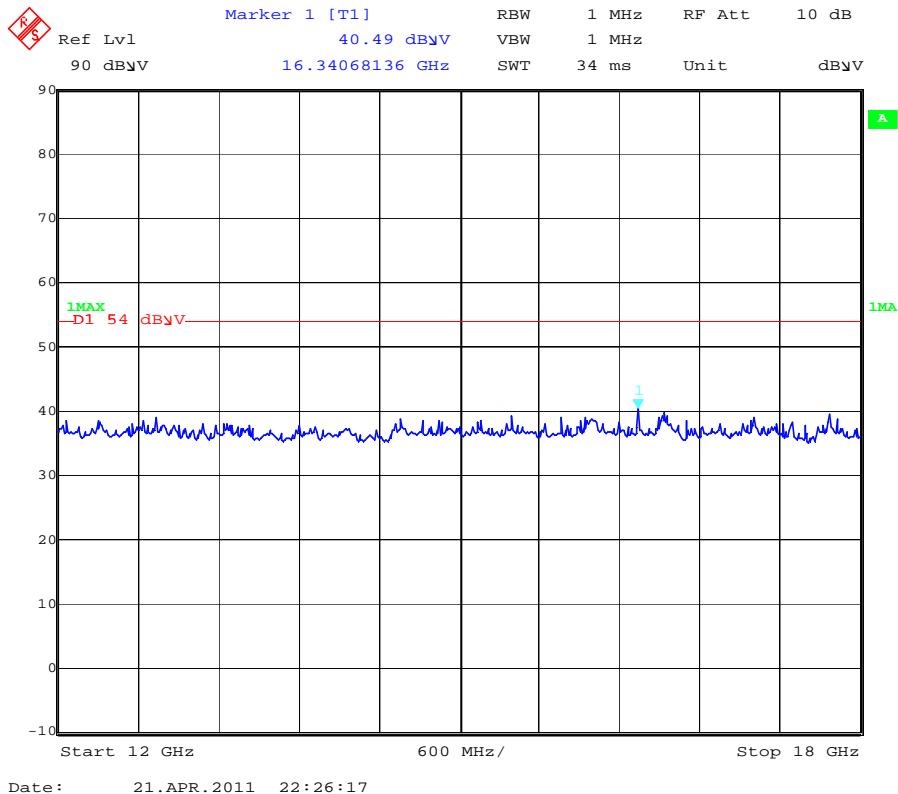

9.11 TX spurious emissions radiated < 30 MHz

Description:

Measurement of the radiated spurious emissions in transmit mode below 30 MHz. The EUT is set to channel 39. This measurement is representative for all channels and modes. If critical peaks are found channel 00 and channel 78 will be measured too. The limits are recalculated to a measurement distance of 3 m with 40 dB/decade according CFR Part 2.

Measurement:

Measurement parameter	
Detector:	Peak / Quasi Peak
Sweep time:	Auto
Video bandwidth:	F < 150 kHz: 200 Hz F > 150 kHz: 9 kHz
Resolution bandwidth:	F < 150 kHz: 1 kHz F > 150 kHz: 100 kHz
Span:	9 kHz to 30 MHz
Trace-Mode:	Max Hold

Limits:

FCC		IC	
CFR Part 15.209(a)		RSS –Gen	
TX Spurious Emissions Radiated < 30 MHz			
Frequency (MHz)	Field Strength (dBµV/m)	Measurement distance	
0.009 – 0.490	2400/F(kHz)	300	
0.490 – 1.705	24000/F(kHz)	30	
1.705 – 30.0	30	30	

Results:

TX Spurious Emissions Radiated < 30 MHz [dBµV/m]		
F [MHz]	Detector	Level [dBµV/m]
No critical peaks found		
Measurement uncertainty	± 3 dB	

Result: The result of the measurement is passed.

Plots: DSSS / ANT+

Plot 1: 9 kHz to 30 MHz / channel 39 (valid for all channels)

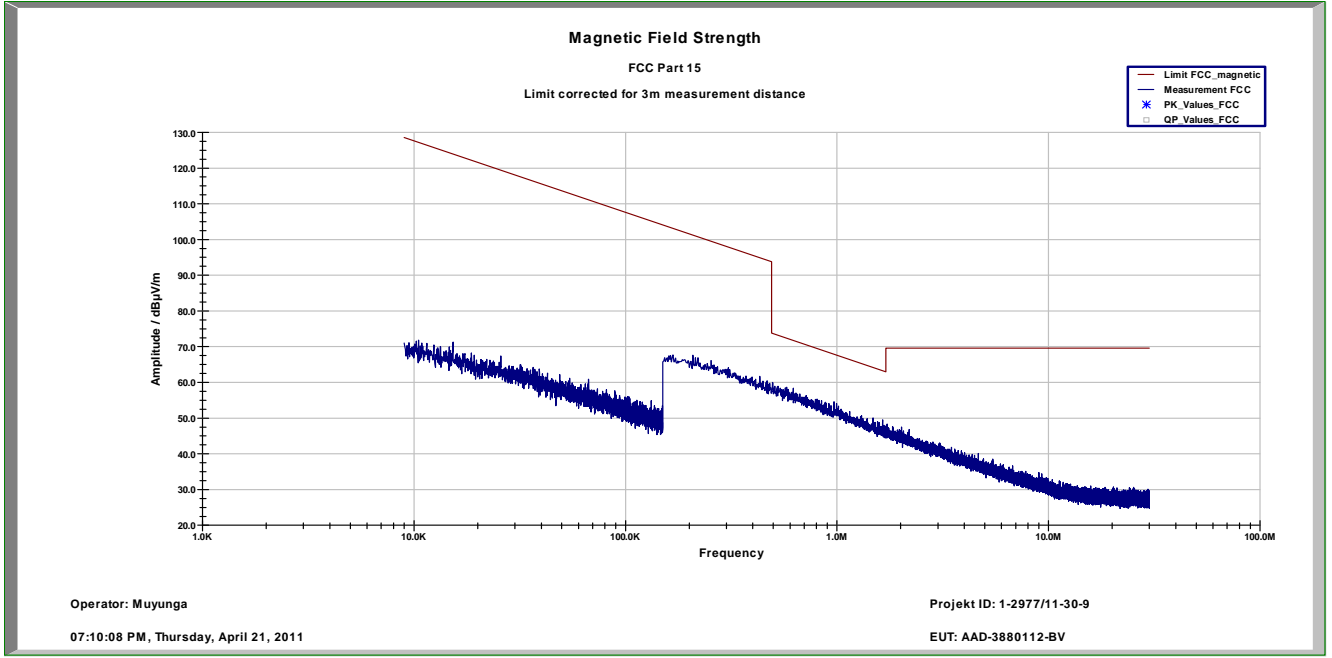

9.12 TX spurious emissions conducted < 30 MHz

Description:

Measurement of the conducted spurious emissions in transmit mode below 30 MHz. The EUT is set to channel 39. If critical peaks are found channel 00 and channel 78 will be measured too. Both power lines, phase and neutral line, are measured. Found peaks are remeasured with average and quasi peak detection to show compliance to the limits.

Measurement:

Measurement parameter	
Detector:	Peak - Quasi Peak / Average
Sweep time:	Auto
Video bandwidth:	F < 150 kHz: 200 Hz F > 150 kHz: 9 kHz
Resolution bandwidth:	F < 150 kHz: 1 kHz F > 150 kHz: 100 kHz
Span:	9 kHz to 30 MHz
Trace-Mode:	Max Hold

Limits:

FCC		IC	
CFR Part 15.107(a)		ICES-003, Issue 4	
TX Spurious Emissions Conducted < 30 MHz			
Frequency (MHz)	Quasi-Peak (dBµV/m)	Average (dBµV/m)	
0.15 – 0.5	66 to 56*	56 to 46*	
0.5 – 5	56	46	
5 – 30.0	60	50	

*Decreases with the logarithm of the frequency

Results:

TX Spurious Emissions Conducted < 30 MHz [dBµV/m]		
F [MHz]	Detector	Level [dBµV/m]
No critical peaks found		
Measurement uncertainty	± 3 dB	

Result: The result of the measurement is passed.

Plot 1: 9 kHz to 30 MHz / phase Line, TX mode

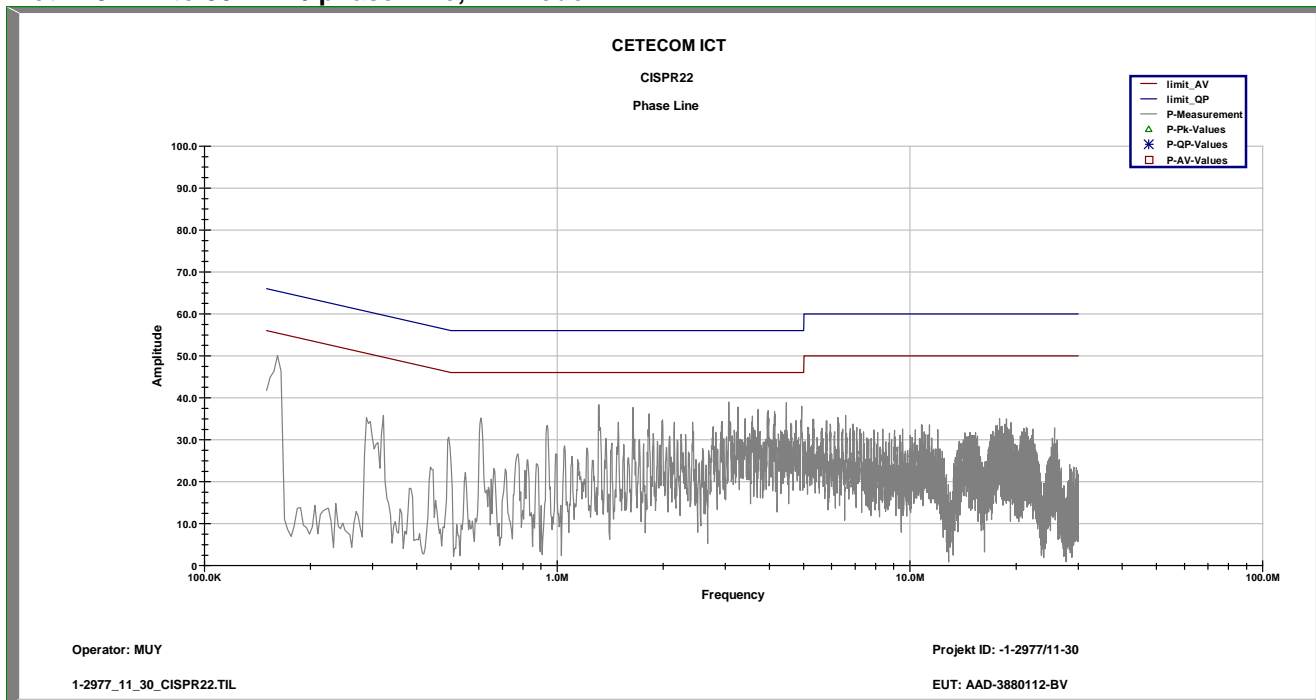

Plot 2: 9 kHz to 30 MHz / neutral Line, TX mode

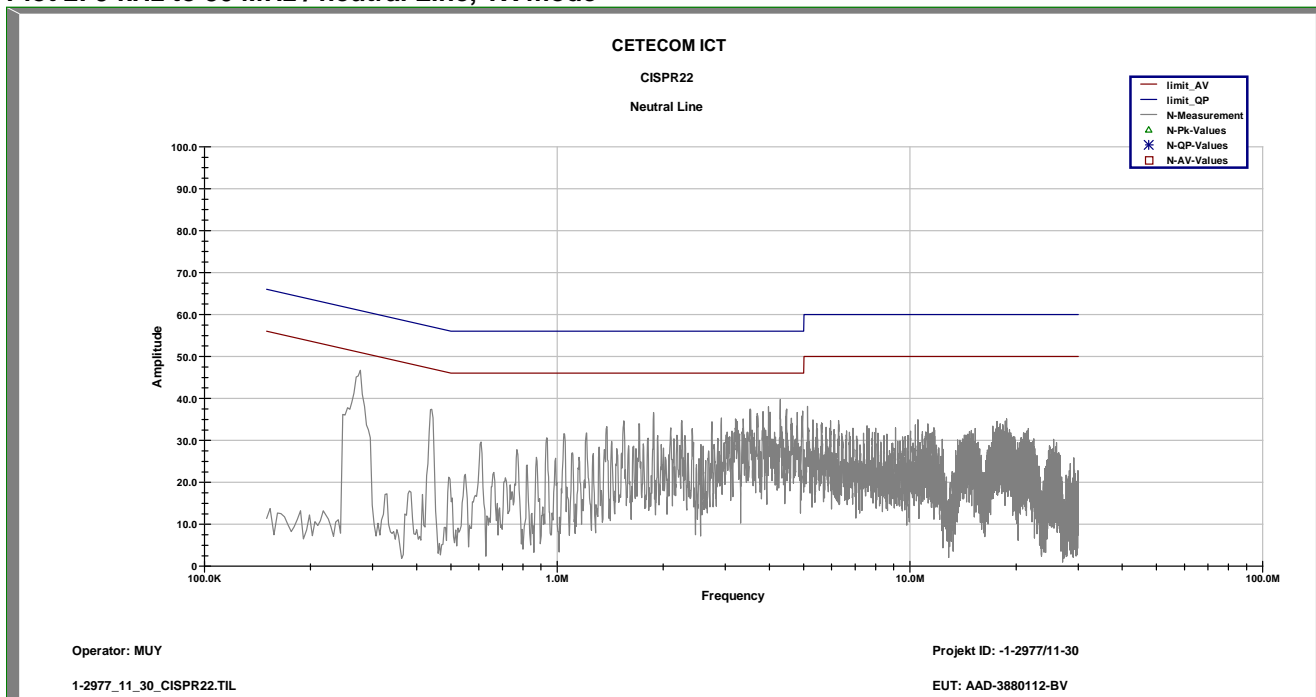

10 Test equipment and ancillaries used for tests

Typically, the calibrations of the test apparatus are commissioned to and performed by an accredited calibration laboratory. The calibration intervals are determined in accordance with the DIN EN ISO/IEC 17025. In addition to the external calibrations, the laboratory executes comparison measurements with other calibrated test systems or effective verifications. Weekly chamber inspections and range calibrations are performed. Where possible, rf-generating and signalling equipment as well as measuring receivers and analyzers are connected to an external high-precision 10 MHz reference (GPS-based or rubidium frequency standard).

In order to simplify the identification of the equipment used at some special tests, some items of test equipment and ancillaries can be provided with an identifier or number in the equipment list below (Labor/Item).

No.	Lab / Item	Equipment	Type	Manufact.	Serial No.	INV. No Cetecom	Kind of Calibration	Last Calibration	Next Calibration
1	n. a.	Switch / Control Unit	3488A	HP Meßtechnik		300001691	ne		
2	n. a.	Power Supply DC	NGPE 40/40	R&S	388	400000078	vlKI!	13.09.2010	13.09.2012
3	n. a.	Power Sensor 50 Ohms, 10 MHz - 18 GHz, 1 nW - 20 mW	NRV-Z1	R&S	833894/011	300002681-0010	k	09.09.2010	09.09.2012
4	n. a.	Hygro-Thermometer	-/-, 5-45°C, 20-100%rF	Thies Clima	-/-	400000080	k	04.05.2010	04.05.2011
5	n. a.	Vector Signal Generator, 300 kHz to 2.2 GHz	SMIQ03B	R&S	835541/055	300002681-0001	k	25.08.2008	25.08.2011
6	n. a.	Vector Signal Generator, 300 kHz to 2.2 GHz	SMIQ03B	R&S	835541/056	300002681-0002	k	26.08.2008	26.08.2011
7	n. a.	Signal Generator 0.01/2 - 20 GHz, Frequ. Resol. 0.1Hz	SMP02	R&S	835133/011	300002681-0003	k	26.08.2008	26.08.2011
8	n. a.	Dual Channel Power Meter	NRVD	R&S	835430/044	300002681-0004	k	13.09.2010	13.09.2012
9	n. a.	Signal Analyzer 20Hz-26,5GHz-150 to + 30 DBM	FSIQ26	R&S	835540/018	300002681-0005	k	07.01.2010	07.01.2012
10	n. a.	Frequency Standard (Rubidium Frequency Standard)	MFS (Rubidium)	R&S (Datum)	002	300002681-0009	Ve	13.09.2010	13.09.2012
11	n. a.	Directional Coupler	101020010	Krytar	70215	300002840	ev		
12	n. a.	DC-Blocker	8143	Inmet Corp.	none	300002842	ne		
13	n. a.	Powersplitter	6005-3	Inmet Corp.		300002841	ev		
14	n. a.	Temperature Test Chamber	VT 4002	Heraeus Voetsch	58566046820010	300003019	Ve	28.05.2009	28.05.2011
15	n. a.	Band Reject filter	WRCG2400/2483-2375/2505-50/10SS	Wainwright	11	300003351	ev		
16	n. a.	TILE-Software Emission	Quantum Change, Modell TILE-ICS/FULL	EMCO	none	300003451	ne		
17	n. a.	Highpass Filter	WHKX2.9/18G-12SS	Wainwright	1	300003492	ev		
18	n. a.	Highpass Filter	WHK1.1/15G-10SS	Wainwright	3	300003255	ev		
19	n. a.	Highpass Filter	WHKX7.0/18G-8SS	Wainwright	18	300003789	ne		
20	n. a.	PSA Spectrum Analyzer 3 Hz - 26.5 GHz	E4440A	Agilent Technologies	MY48250080	300003812	k	08.09.2010	08.09.2012
21	n. a.	MXG Microwave Analog Signal	N5183A	Agilent Technologies	MY47420220	300003813	k	13.09.2010	13.09.2012

		Generator							
22	n. a.	RF Filter Section 9kHz - 1GHz	N9039A	Agilent Technologies	MY48260003	300003825	vIKI!	08.09.2010	08.09.2012
23	n. a.	TRILOG Broadband Test-Antenna 30 MHz - 3 GHz	VULB9163	Schwarzbeck	371	300003854	vIKI!	17.12.2008	17.12.2011
24	50	DC power supply, 60Vdc, 50A, 1200 W	6032A	HP Meßtechnik	2920A04466	300000580	k	06.01.2009	06.01.2011
25	n. a.	EMI Test Receiver	ESCI 1166.5950.03	R&S	100083	300003312	k	05.01.2011	05.01.2013
26	n. a.	Analyzer-Reference-System (Harmonics and Flicker)	ARS 16/1	SPS	A3509 07/0 0205	300003314	k	01.06.2009	01.06.2011
27	n. a.	Amplifier	JS42-00502650-28-5A	MITEQ	1084532	300003379	ev		
28	n. a.	Antenna Tower	Model 2175	ETS-LINDGREN	64762	300003745	izw		
29	n. a.	Positioning Controller	Model 2090	ETS-LINDGREN	64672	300003746	izw		
30	n. a.	Turntable Interface-Box	Model 105637	ETS-LINDGREN	44583	300003747	izw		
31	n. a.	TRILOG Broadband Test-Antenna 30 MHz - 3 GHz	VULB9163	Schwarzbeck	295	300003787	k	01.04.2010	01.04.2012
32	n. a.	Spectrum-Analyzer	FSU26	R&S	200809	300003874	k	10.01.2011	10.01.2013
33	n. a.	CBT (Bluetooth Tester + EDR Signalling)	CBT 1153.9000K35	R&S	100185	300003416	vIKI!	13.09.2010	13.09.2012
34	n. a.	Spectrum Analyzer 9kHz to 30GHz - 140...+30dBm	FSP30	R&S	100886	300003575	k	07.09.2010	07.09.2012
35	n. a.	CBT-K57 Software-Option for CBT/CBT32	CBT-K57	R&S	101051	300003910	ne		
36	n. a.	DC power supply, 60Vdc, 50A, 1200 W	6032A	HP Meßtechnik	2818A03450	300001040	Ve	08.01.2009	08.01.2012
37	n. a.	Coaxial Attenuator 30dB/500W	8325	Bird	1530	300001595	ev		
38	n. a.	Double-Ridged Waveguide Horn Antenna 1-18.0GHz	3115	EMCO	8812-3088	300001032	vIKI!	05.03.2009	05.09.2011
39	n. a.	Active Loop Antenna	6502	EMCO	2210	300001015	ne		
40	n. a.	Anechoic chamber	FAC 3/5m	MWB / TDK	87400/02	300000996		23.03.2009	
41	Spec.A. 2_2e	System rack for EMI measurement solution	85900	HP I.V.	*	300000222	ne		
42	9	Artificial Mains 9 kHz to 30 MHz	ESH3-Z5	R&S	828576/020	300001210	Ve	06.01.2010	06.01.2012
43	n. a.	Relais Matrix	3488A	HP Meßtechnik	2719A15013	300001156	ne		
44	n. a.	Relais Matrix	PSU	R&S	890167/024	300001168	ne		
45	n. a.	Isolating Transformer	RT5A	Grundig	9242	300001263	ne		
46	n. a.	Three-Way Power Splitter, 50 Ohm	11850C	HP Meßtechnik		300000997	ne		
47	n. a.	Switch / Control Unit	3488A	HP	2605e08770	300001443	ne		
48	n. a.	Amplifier	js42-00502650-	Parzich	928979	300003143	ne		

			28-5a	GMBH					
49	n. a.	Band Reject filter	WRCG1855/1910-1835/1925-40/8SS	Wainwright	7	300003350	ev		

Agenda: Kind of Calibration

- | | | | |
|------|--|-----|--|
| k | calibration / calibrated | EK | limited calibration |
| ne | not required (k, ev, izw, zw not required) | zw | cyclical maintenance (external cyclical maintenance) |
| ev | periodic self verification | izw | internal cyclical maintenance |
| Ve | long-term stability recognized | g | blocked for accredited testing |
| vlk! | Attention: extended calibration interval | | |
| NK! | Attention: not calibrated | *) | next calibration ordered / currently in progress |