



TEST REPORT

Test report no.: 1-1954-56-06/10



Testing laboratory

CETECOM ICT Services GmbH
Untertuerkheimer Strasse 6 – 10
66117 Saarbruecken / Germany
Phone: + 49 681 5 98 - 0
Fax: + 49 681 5 98 - 9075
Internet: <http://www.cetecom.com>
e-mail: ict@cetecom.com

Accredited test laboratory:
The test laboratory (area of testing) is accredited according to DIN EN ISO/IEC 17025
DAR registration number: DGA-PL-176/94-D1
Area of Testing: Radio/Satellite Communications

Applicant

Sony Ericsson Mobile Communications AB
Nya Vattentornet
22188 Lund / Sweden
Phone: +46 46 19 30 00
Fax: +46 46 19 32 95
Contact: Johan Wedin
e-mail: johan.wedin@sonyericsson.com
Phone: +46 70 71 95 73 6

Manufacturer

Sony Ericsson Mobile Communications AB
Nya Vattentornet
22188 Lund / Sweden

Test standard/s

47 CFR Part 15 Title 47 of the Code of Federal Regulations; Chapter I
Part 15 - Radio frequency devices

RSS - 210 Issue 8 Spectrum Management and Telecommunications - Radio Standards Specification
Low-power Licence-exempt Radiocommunication Devices (All Frequency Bands):
Category I Equipment

For further applied test standards please refer to section 3 of this test report.

Test item

Kind of test item: Mobile Phone GSM/EDGE 850,900,1800,1900; UMTS FDD1, FDD8; BT2.1+EDR; WLAN; A-GPS

Model name: AAD-3880100-BV

FCC ID: PY7A3880100

IC: 4170B-A3880100

Frequency [MHz]: ISM band 2400 MHz to 2483.5 MHz
(lowest channel 2412 MHz, highest channel 2462 MHz)

Power supply: 3.7 V DC by power supply / battery + charger

Temperature range: -20 °C to +55 °C

Test performed:

2011-03-03 Joerg Warken

Test report authorised:

2011-03-03 Stefan Bös

1 Table of contents	
1	Table of contents.....2
2	General information3
2.1	Notes.....3
2.2	Application details.....3
3	Test standard/s3
4	Test environment.....3
5	Test item4
6	Test laboratories sub-contracted4
7	Summary of measurement results5
8	RF measurement testing.....6
8.1	Description of test setup6
8.1.1	Radiated measurements.....6
8.1.2	Conducted measurements.....7
8.2	Additional comments7
8.3	RSP100 test report cover sheet / performance test data8
9	Measurement results.....9
9.1	Maximum output power (conducted)9
9.2	Antenna gain20
9.3	Power spectral density23
9.4	Spectrum bandwidth of a FHSS system – 6 dB bandwidth29
9.5	Spectrum bandwidth of a FHSS system – 20 dB bandwidth35
9.6	Maximum output power41
9.7	Band edge compliance conducted43
9.8	Band edge compliance radiated47
9.9	TX spurious emissions conducted.....54
9.10	TX spurious emissions radiated.....63
9.11	RX spurious emissions radiated101
9.12	TX spurious emissions radiated < 30 MHz.....106
9.13	TX spurious emissions conducted < 30 MHz.....109
10	Test equipment and ancillaries used for tests114
Annex A	Photographs of the test setup.....116
Annex B	External photographs of the EUT.....121
Annex C	Internal photographs of the EUT127
Annex D	Document history137
Annex E	Further information.....137

2 General information

2.1 Notes

The test results of this test report relate exclusively to the test item specified in this test report. CETECOM ICT Services GmbH does not assume responsibility for any conclusions and generalisations drawn from the test results with regard to other specimens or samples of the type of the equipment represented by the test item. The test report may only be reproduced or published in full. Reproduction or publication of extracts from the report requires the prior written approval of CETECOM ICT Services GmbH.

2.2 Application details

Date of receipt of order:	2010-11-29
Date of receipt of test item:	2011-02-16
Start of test:	2011-02-16
End of test:	2011-03-03
Person(s) present during the test:	-/-

3 Test standard/s

Test standard	Version	Test standard description
47 CFR Part 15	2009-10	Title 47 of the Code of Federal Regulations; Chapter I Part 15 - Radio frequency devices
RSS - 210 Issue 8	2010-12	Spectrum Management and Telecommunications - Radio Standards Specification Low-power Licence-exempt Radiocommunication Devices (All Frequency Bands): Category I Equipment

4 Test environment

Temperature:	T_{nom}	+20 °C during room temperature tests
	T_{max}	+55 °C during high temperature test
	T_{min}	-20 °C during low temperature test
Relative humidity content:		42 %
Air pressure:		not relevant for this kind of testing
Power supply:	V_{nom}	3.7 V DC by power supply / battery + charger
	V_{max}	4.1 V
	V_{min}	3.3 V

5 Test item

Kind of test item	:	Mobile Phone GSM/EDGE 850,900,1800,1900; UMTS FDD1, FDD8; BT2.1+EDR; WLAN; A-GPS
Type identification	:	AAD-3880100-BV
S/N serial number	:	Radiated units: CB5A1CGUK1, CB5A1CGN7M Conducted units: CB5A1CGMVK, CB5A1CGN82
HW hardware status	:	AP1.2
SW software status	:	3.0.A.2.42 ATP
Frequency band [MHz]	:	ISM band 2400 MHz to 2483.5 MHz (lowest channel 2412 MHz, highest channel 2462 MHz)
Type of modulation	:	DSSS & OFDM technology with BPSK, QPSK, 16- & 64-QAM modulation.
Number of channels	:	11
Antenna	:	Integrated PCB antenna → for more information, please take a look at the annex – internal photos of the EUT.
Power supply	:	3.7 V DC by power supply / battery + charger
Temperature range	:	-20°C to +55 °C

6 Test laboratories sub-contracted

None

7 Summary of measurement results

- No deviations from the technical specifications were ascertained
- There were deviations from the technical specifications ascertained

TC Identifier	Description	Verdict	Date	Remark
RF-Testing	CFR Part 15 RSS 210, Issue 8, Annex 8	Passed	2011-03-03	-/-

Test specification clause	Test case	Temperature conditions	Power source voltages	Mode	Pass	Fail	NA	NP	Results (max.)
§15.247(b)(4) RSS 210 / A8.4(2)	Antenna gain	Nominal	Nominal	DSSS	<input checked="" type="checkbox"/>	<input type="checkbox"/>	<input type="checkbox"/>	<input type="checkbox"/>	complies
§15.247(e) RSS 210 / A8.2(b)	Power spectral density	Nominal	Nominal	DSSS OFDM	<input checked="" type="checkbox"/> <input checked="" type="checkbox"/>	<input type="checkbox"/> <input type="checkbox"/>	<input type="checkbox"/> <input type="checkbox"/>	<input type="checkbox"/> <input type="checkbox"/>	complies
§15.247(a)(2) RSS 210 / A8.2(a)	Spectrum bandwidth of a FHSS system 6dB bandwidth	Nominal	Nominal	DSSS OFDM	<input checked="" type="checkbox"/> <input checked="" type="checkbox"/>	<input type="checkbox"/> <input type="checkbox"/>	<input type="checkbox"/> <input type="checkbox"/>	<input type="checkbox"/> <input type="checkbox"/>	complies
§15.247(a)(2) RSS 210 / A8.2(a)	Spectrum bandwidth of a FHSS system 20dB bandwidth	Nominal	Nominal	DSSS OFDM	<input checked="" type="checkbox"/> <input checked="" type="checkbox"/>	<input type="checkbox"/> <input type="checkbox"/>	<input type="checkbox"/> <input type="checkbox"/>	<input type="checkbox"/> <input type="checkbox"/>	complies
§15.247(b)(3) RSS-210 / A8.4(4)	Maximum output power	Nominal	Nominal	DSSS OFDM	<input checked="" type="checkbox"/> <input checked="" type="checkbox"/>	<input type="checkbox"/> <input type="checkbox"/>	<input type="checkbox"/> <input type="checkbox"/>	<input type="checkbox"/> <input type="checkbox"/>	complies
§15.247(d) RSS-210 / A8.5	Band edge compliance conducted	Nominal	Nominal	DSSS OFDM	<input checked="" type="checkbox"/> <input checked="" type="checkbox"/>	<input type="checkbox"/> <input type="checkbox"/>	<input type="checkbox"/> <input type="checkbox"/>	<input type="checkbox"/> <input type="checkbox"/>	complies
§15.205 RSS-210 / A8.5	Band edge compliance radiated	Nominal	Nominal	DSSS OFDM	<input checked="" type="checkbox"/> <input checked="" type="checkbox"/>	<input type="checkbox"/> <input type="checkbox"/>	<input type="checkbox"/> <input type="checkbox"/>	<input type="checkbox"/> <input type="checkbox"/>	complies
§15.247(d) RSS-210 / A8.5	TX spurious emissions conducted	Nominal	Nominal	DSSS OFDM	<input checked="" type="checkbox"/> <input checked="" type="checkbox"/>	<input type="checkbox"/> <input type="checkbox"/>	<input type="checkbox"/> <input type="checkbox"/>	<input type="checkbox"/> <input type="checkbox"/>	complies
§15.247(d) RSS-210 / A8.5	TX spurious emissions radiated	Nominal	Nominal	DSSS OFDM	<input checked="" type="checkbox"/> <input checked="" type="checkbox"/>	<input type="checkbox"/> <input type="checkbox"/>	<input type="checkbox"/> <input type="checkbox"/>	<input type="checkbox"/> <input type="checkbox"/>	complies
§15.109 RSS-Gen.	RX spurious emissions radiated	Nominal	Nominal	-/-	<input checked="" type="checkbox"/>	<input type="checkbox"/>	<input type="checkbox"/>	<input type="checkbox"/>	complies
§15.209(a) RSS-Gen	TX spurious emissions radiated < 30 MHz	Nominal	Nominal	DSSS OFDM	<input checked="" type="checkbox"/> <input checked="" type="checkbox"/>	<input type="checkbox"/> <input type="checkbox"/>	<input type="checkbox"/> <input type="checkbox"/>	<input type="checkbox"/> <input type="checkbox"/>	complies
§15.107(a)	Conducted emissions < 30 MHz	Nominal	Nominal	DSSS OFDM	<input checked="" type="checkbox"/> <input checked="" type="checkbox"/>	<input type="checkbox"/> <input type="checkbox"/>	<input type="checkbox"/> <input type="checkbox"/>	<input type="checkbox"/> <input type="checkbox"/>	complies

Note: NA = Not Applicable; NP = Not Performed

8 RF measurement testing

8.1 Description of test setup

8.1.1 Radiated measurements

The radiated measurements are performed in vertical and horizontal plane in the frequency range from 9 kHz to 25 GHz in semi-anechoic chambers. The EUT is positioned on a non-conductive support with a height of 0.80 m above a conductive ground plane that covers the whole chamber. The receiving antennas are confirmed with specifications ANSI C63.2-1996 clause 15 and ANSI C63.4-2009 clause 4.1.5. These antennas can be moved over the height range between 1.0 m and 4.0 m in order to search for maximum field strength emitted from EUT. The measurement distances between EUT and receiving antennas are indicated in the test setups for the various frequency ranges. For each measurement, the EUT is rotated in all three axes until the maximum field strength is received. The wanted and unwanted emissions are received by spectrum analysers where the detector modes and resolution bandwidths over various frequency ranges are set according to requirement ANSI C63-4-2009 clause 4.2.

Antennas are confirmed with ANSI C63.2-1996 item 15.

Semi anechoic chamber

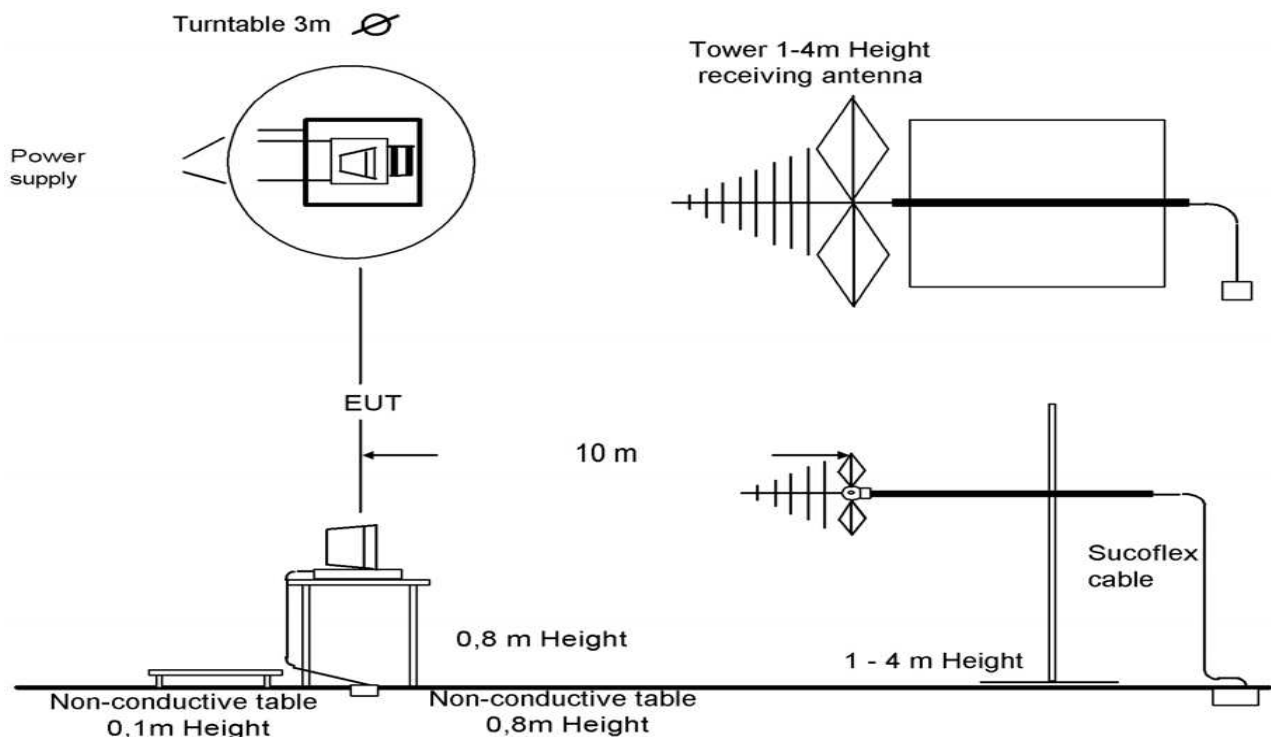

Picture 1: Diagram radiated measurements

9 kHz - 30 MHz:	active loop antenna
30 MHz – 1 GHz:	tri-log antenna
> 1 GHz:	horn antenna

The EUT is powered by an external power supply with nominal voltage. The signalling is performed from outside the chamber with a signalling unit (CMU200 or other) by air link using signalling antenna.

8.1.2 Conducted measurements

The EUT's RF signal is coupled out by the antenna connector which is supplied by the manufacturer. The signal is first 10dB attenuated before it is power divided (~6dB loss per branch). One of the signal paths is connected to the communication base Station (CMU200 or other), the other one is connected to the spectrum analyzer. The specific losses for both signal paths are first checked within a calibration. The measurement readings on the signalling unit/spectrum analyzer are corrected by the specific test set-up loss. The attenuator, power divider, signalling unit and the spectrum analyzer are impedance matched on 50 Ohm.

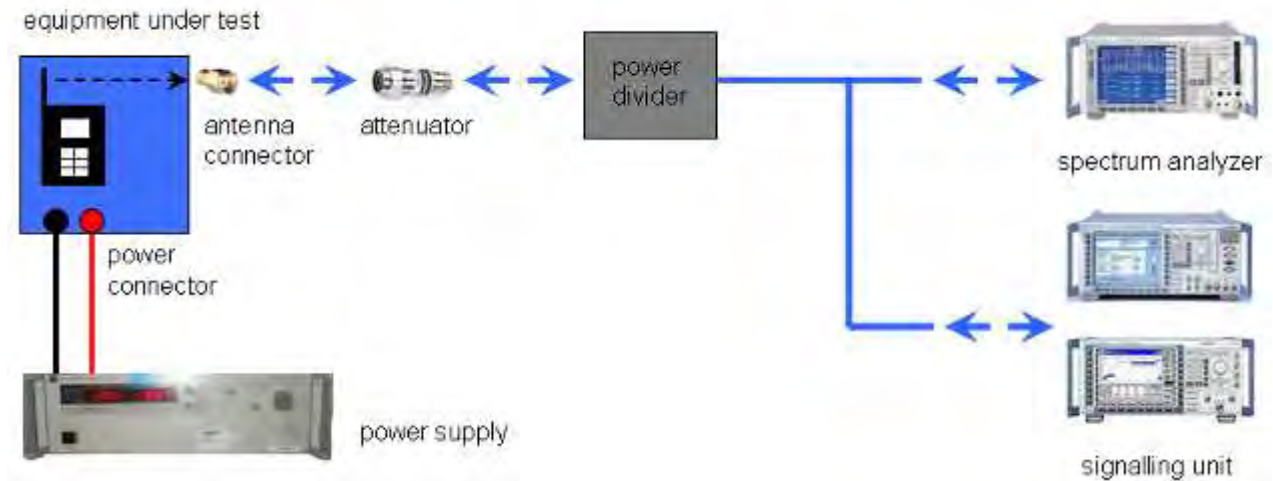

Picture 2: Diagram conducted measurements

8.2 Additional comments

Reference documents: None

Special test descriptions: None

Configuration descriptions: None

- Test mode:
- No test mode available.
lperf was used to ping another device with the largest support packet size
 - Special software is used.
EUT is transmitting pseudo random data by itself

8.3 RSP100 test report cover sheet / performance test data

Test report number	:	1-1954-56-06/10
Equipment model number	:	AAD-3880100-BV
Certification number	:	4170B-A3880100
Manufacturer (complete address)	:	Sony Ericsson Mobile Communications AB Nya Vattentornet 22188 Lund / Sweden
Tested to radio standards specification no.	:	RSS 210, Issue 8, Annex 8
Open area test site IC No.	:	IC 3462C-1
Frequency range	:	ISM band 2400 MHz to 2483.5 MHz (lowest channel 2412 MHz, highest channel 2462 MHz)
RF-power [W] (max.)	:	cond.: 96.61 mW (DSSS / b – mode) 239.88 mW (OFDM / g – mode) 242.66 mW (OFDM / n – mode) EIRP: 51.52 mW (DSSS / b – mode) 135.83 mW (OFDM / g – mode) 137.40 mW (OFDM / n – mode)
Occupied bandwidth (99%-BW) [kHz]	:	DSSS / b – mode: 15.57 MHz OFDM / g – mode: 17.98 MHz OFDM / n – mode: 18.88 MHz
Type of modulation	:	DSSS & OFDM technology with BPSK, QPSK, 16- and 64 QAM modulation.
Emission designator (TRC-43)	:	15M6G1D (DSSS / b – mode) 18M0G7D (OFDM / g – mode) 18M9G7D (OFDM / n – mode)
Antenna information	:	Integrated PCB antenna → for more information, please take a look at the annex – internal photos of the EUT.
Transmitter spurious (worst case)[dB μ V/m @ 3m]:		49.69 dB μ V/m @ 19.49 GHz
Receiver spurious (worst case) [dB μ V/m @ 3m]:		43.00 dB μ V/m @ 19.54 GHz

ATTESTATION:

DECLARATION OF COMPLIANCE:

I attest that the testing was performed or supervised by me; that the test measurements were made in accordance with the above-mentioned Industry Canada standard(s); and that the equipment identified in this application has been subjected to all the applicable test conditions specified in the Industry Canada standards and all of the requirements of the standard have been met.

Laboratory manager:

2011-03-03

Joerg Warken

Date

Name

Signature

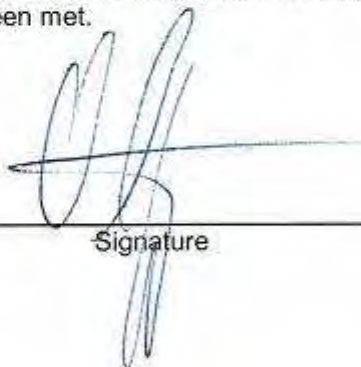

9 Measurement results

9.1 Maximum output power (conducted)

Description:

Measurement of the maximum output power conducted. This measurement is performed only at the middle channel in both modes and all data rates to determine the data rate per mode which results in the highest output power. This mode will be selected for all further measurements.

Measurement:

Measurement parameter	
Detector:	Peak
Sweep time:	Auto
Video bandwidth:	30 MHz
Resolution bandwidth:	50 MHz
Span:	30 MHz
Trace-Mode:	Max Hold

Results:

DSSS / b – mode Data Rate [MBit/s]	Maximum Output Power Conducted [dBm]			
	1	2	5.5	11
Ch 6 - 2437 MHz	20.37	20.36	20.15	20.09
Measurement uncertainty	± 0.5 dB			

OFDM / g – mode Data Rate [MBit/s]	Maximum Output Power Conducted [dBm]							
	6	9	12	18	24	36	48	54
Ch 6 - 2437 MHz	23.36	23.27	23.14	23.06	23.21	23.27	23.24	23.08
Measurement uncertainty	± 0.5 dB							

OFDM / n – mode Data Rate [MBit/s]	Maximum Output Power Conducted [dBm]							
	MCS0	MCS1	MCS2	MCS3	MCS4	MCS5	MCS6	MCS7
Ch 6 - 2437 MHz	23.30	23.04	23.13	23.10	23.10	22.72	22.90	22.79
Measurement uncertainty	± 0.5 dB							

Result: Selected data rate for all measurements:

DSSS / b – mode:

OFDM / g – mode:

OFDM / n – mode:

1 MBit/s

6 MBit/s

MCS0

Plots: DSSS / b – mode

Plot 1: TX mode, middle channel, 1 MBit/s

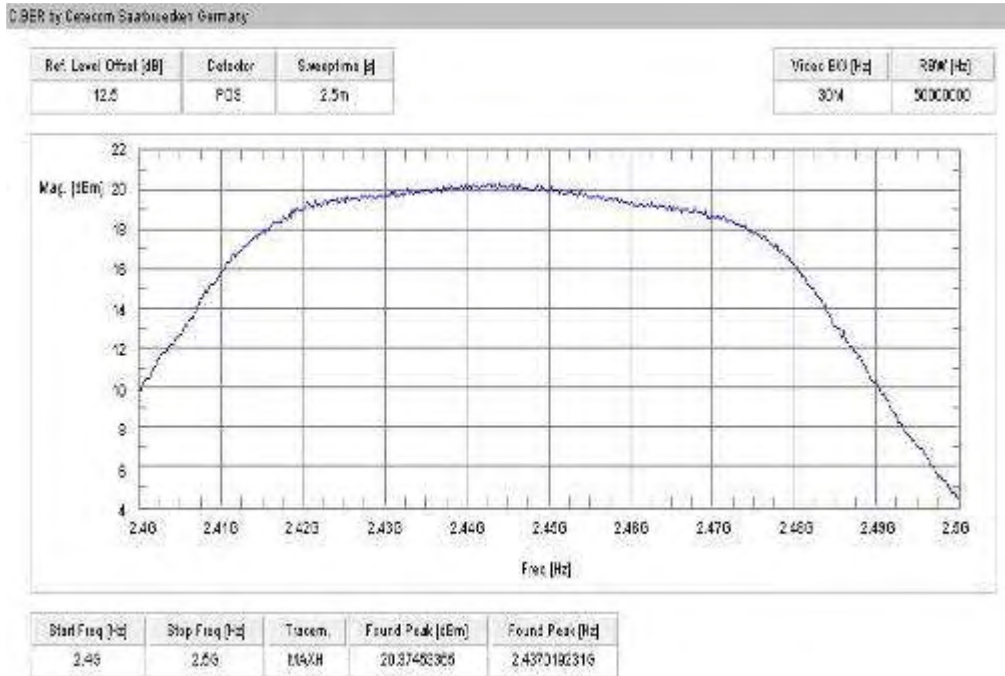

Plot 2: TX mode, middle channel, 2 MBit/s

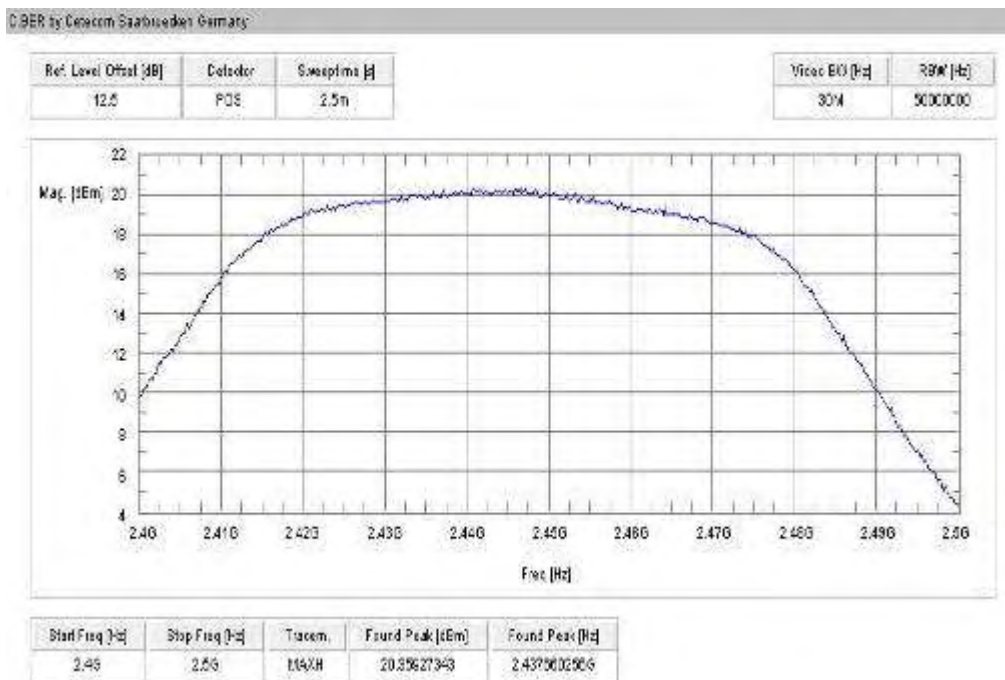

Plot 3: TX mode, middle channel, 5.5 MBit/s

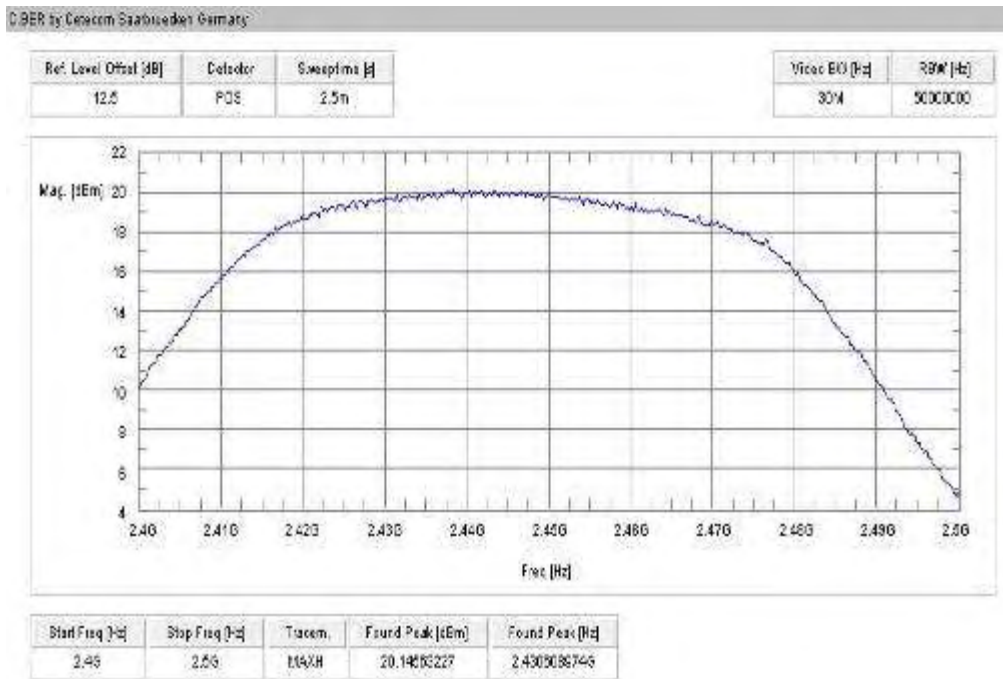

Plot 4: TX mode, middle channel, 11 MBit/s

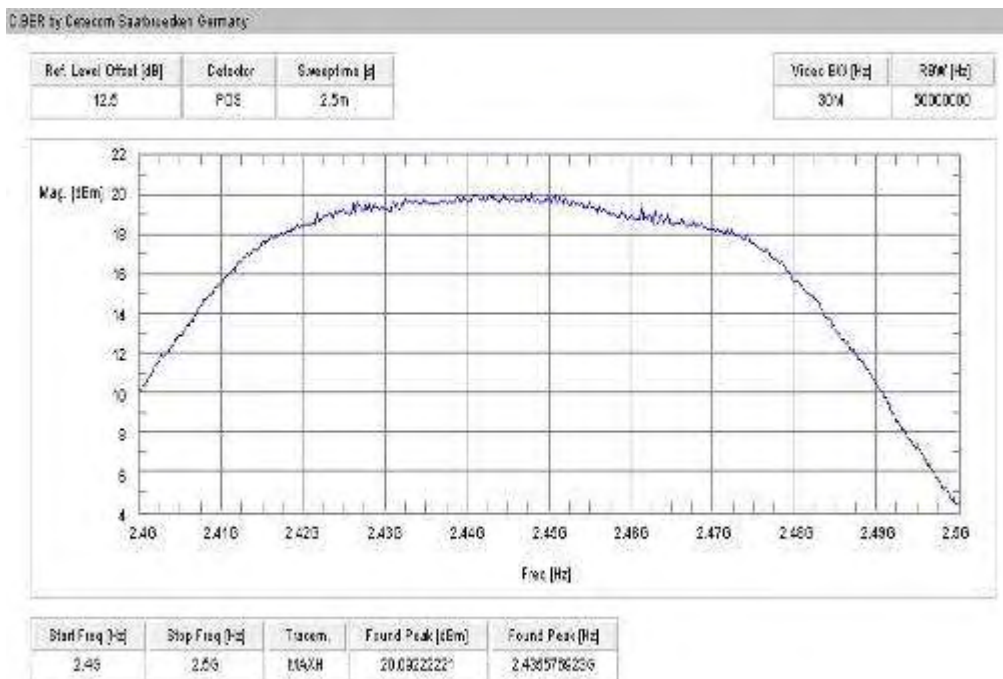

Plots: OFDM / g – mode

Plot 1: TX mode, middle channel, 6 MBit/s

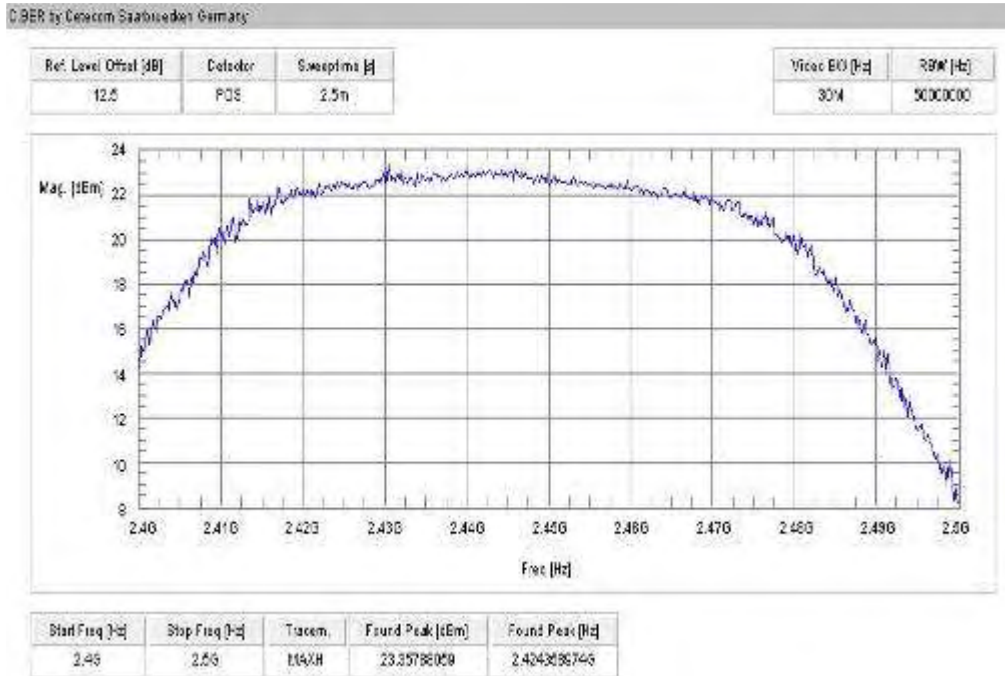

Plot 2: TX mode, middle channel, 9 MBit/s

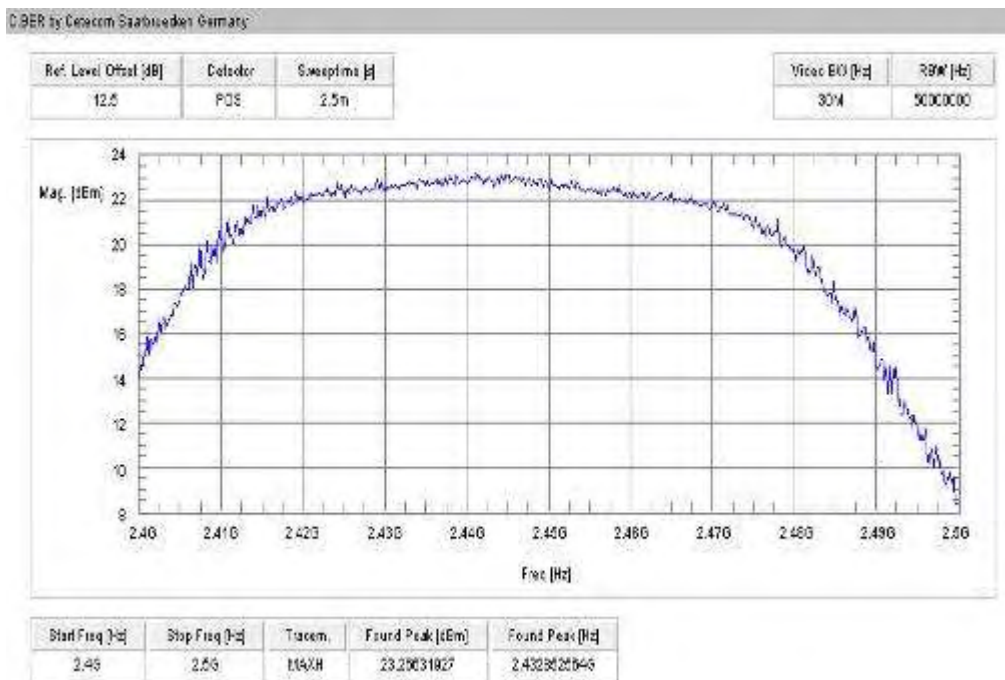

Plot 3: TX mode, middle channel, 12 MBit/s

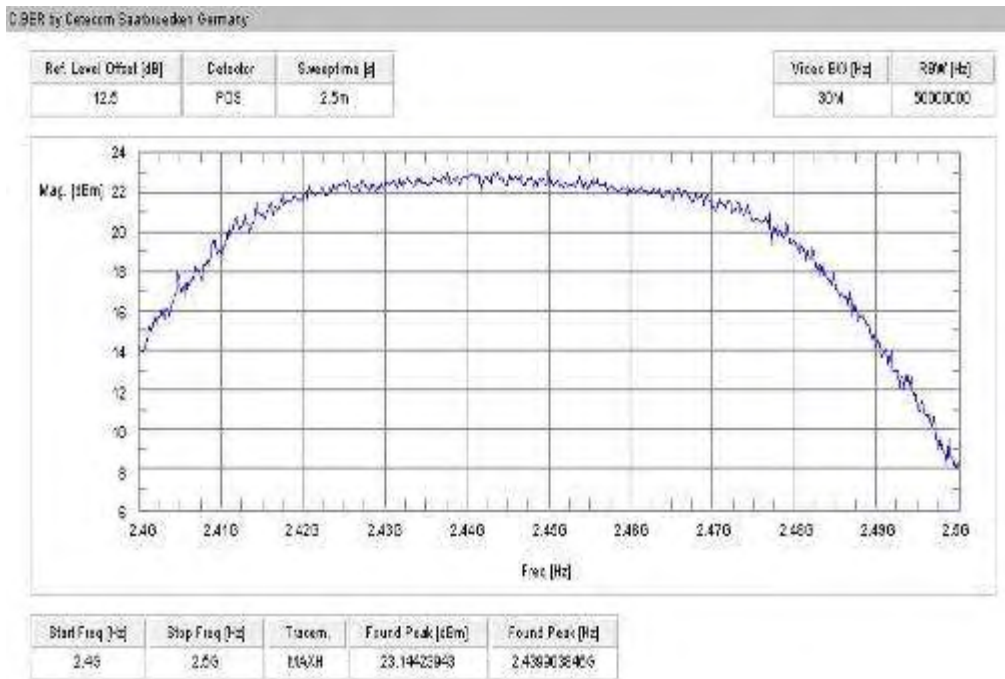

Plot 4: TX mode, middle channel, 18 MBit/s

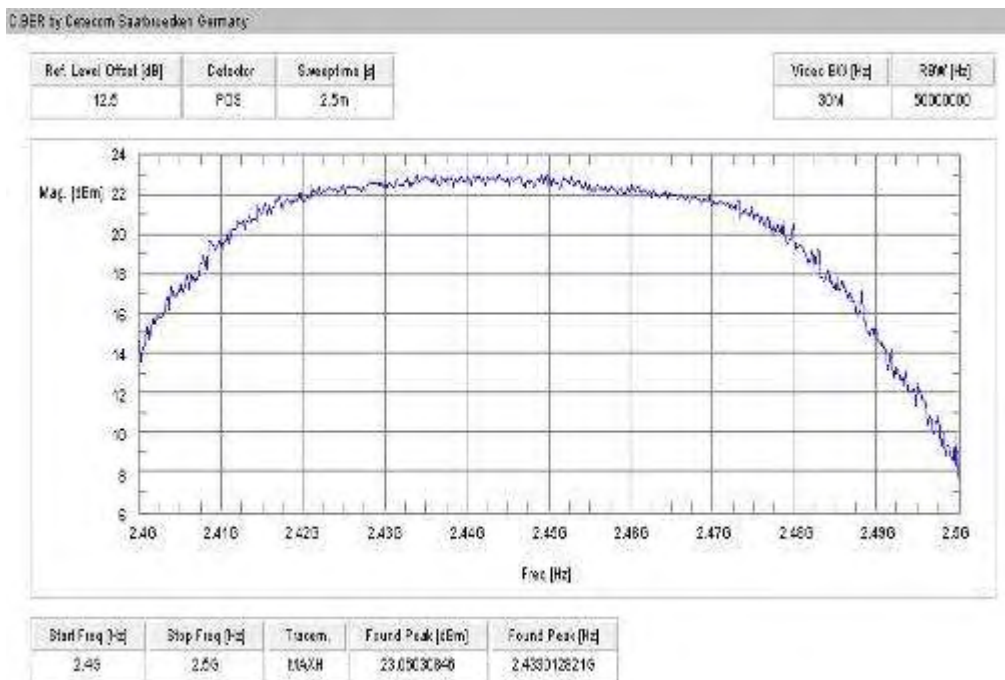

Plot 5: TX mode, middle channel, 24 MBit/s

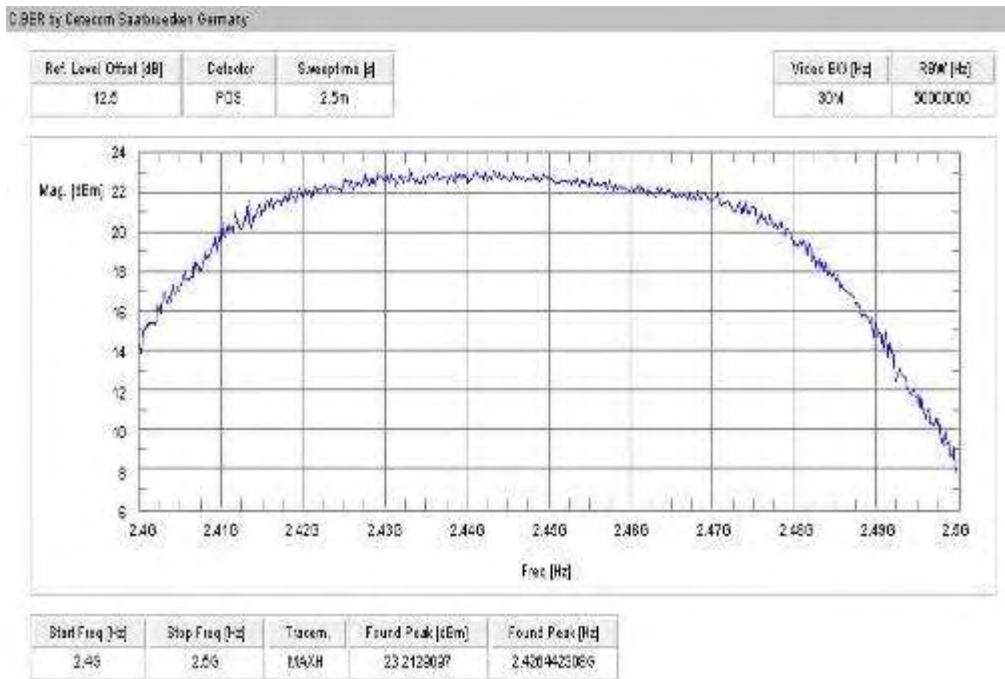

Plot 6: TX mode, middle channel, 36 MBit/s

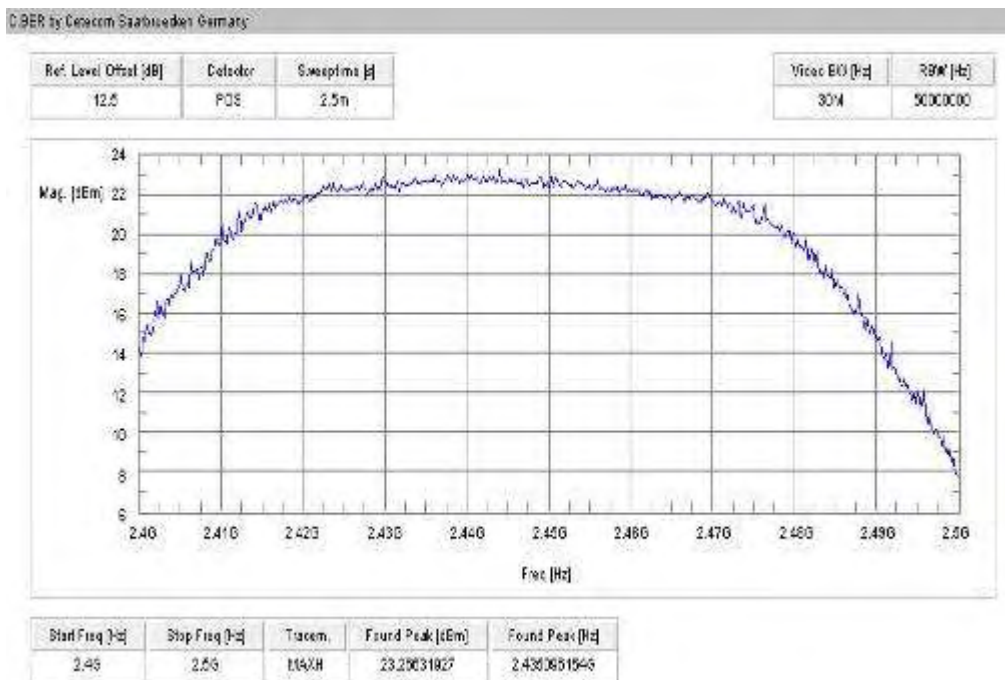

Plot 7: TX mode, middle channel, 48 MBit/s

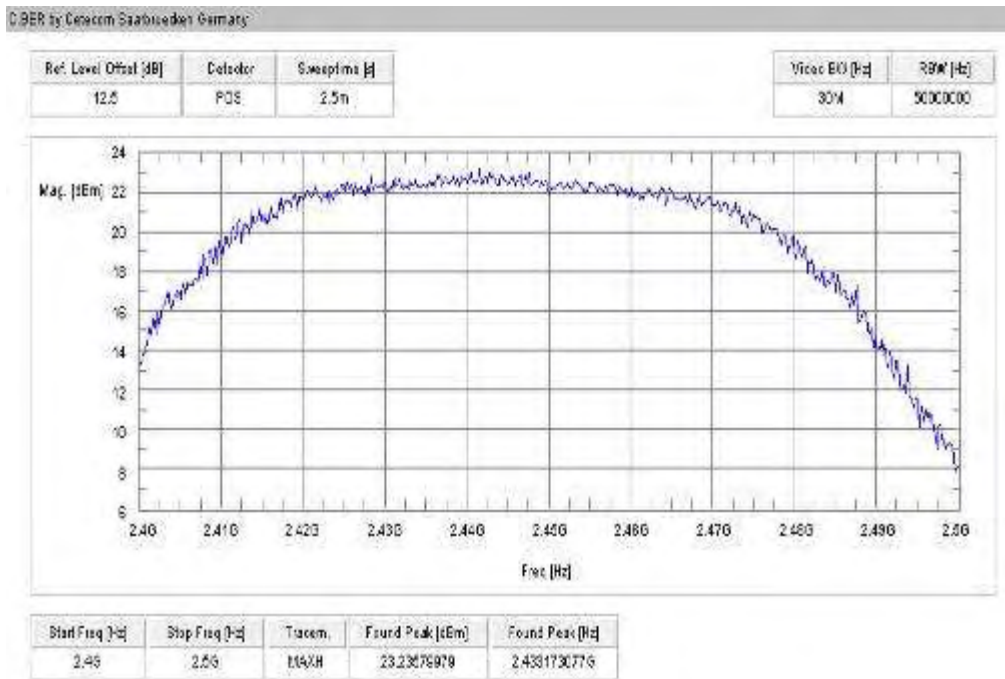

Plot 8: TX mode, middle channel, 54 MBit/s

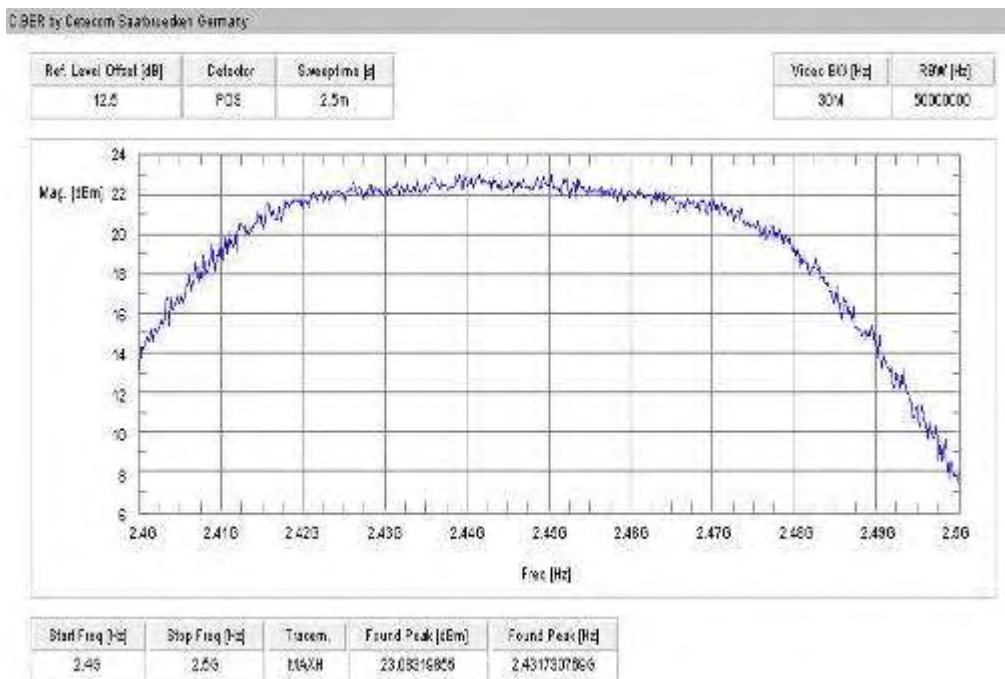

Plots: OFDM / n – mode

Plot 1: TX mode, middle channel, MCS 0

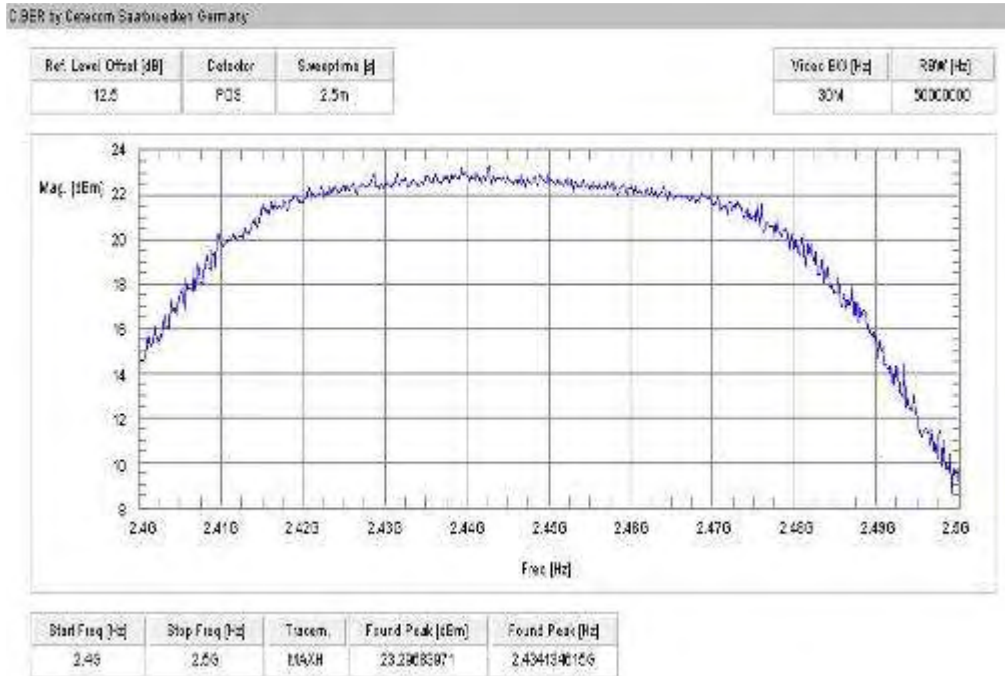

Plot 2: TX mode, middle channel, MCS 1

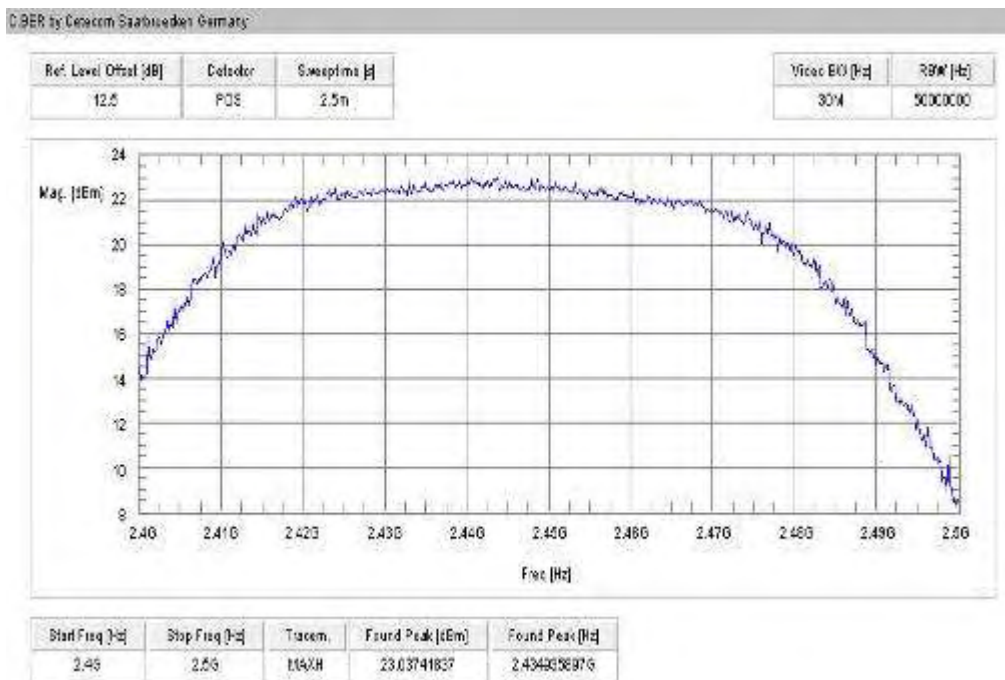

Plot 3: TX mode, middle channel, MCS 2

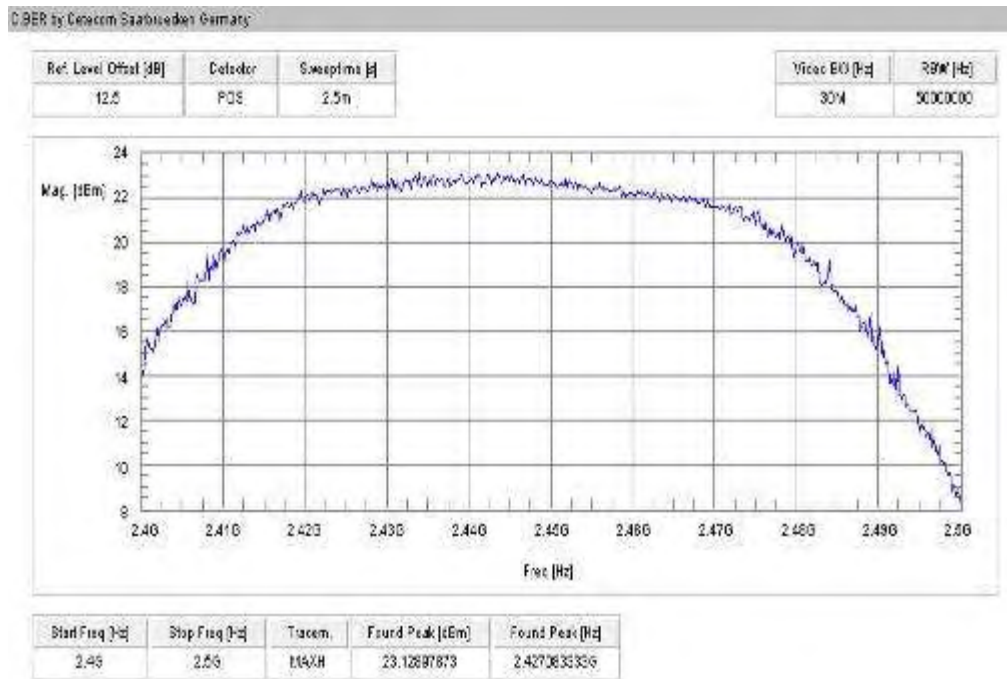

Plot 4: TX mode, middle channel, MCS 3

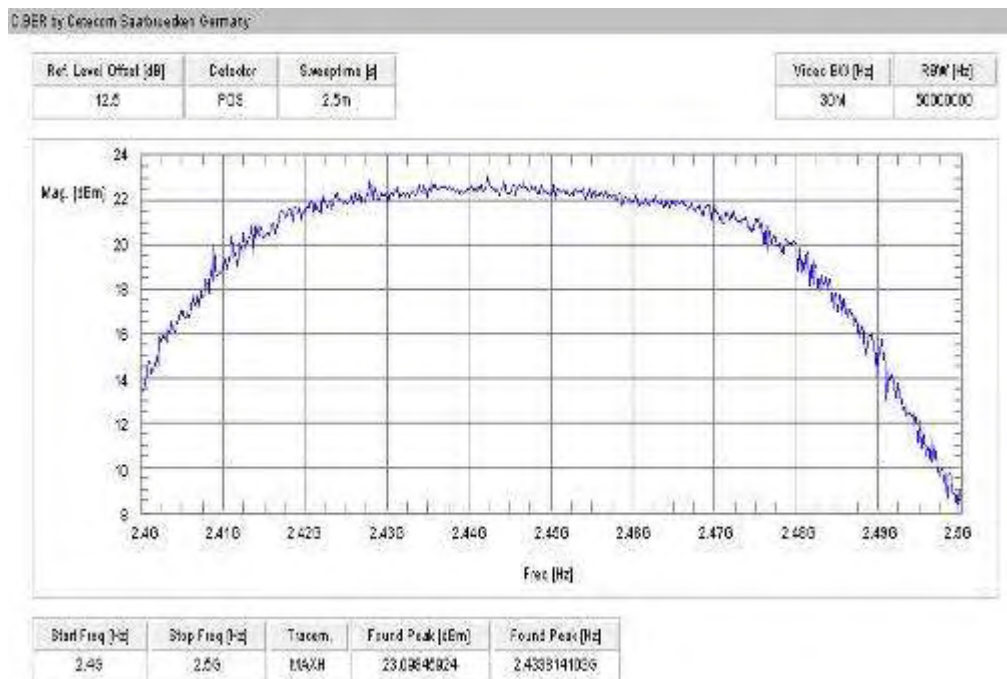

Plot 5: TX mode, middle channel, MCS 4

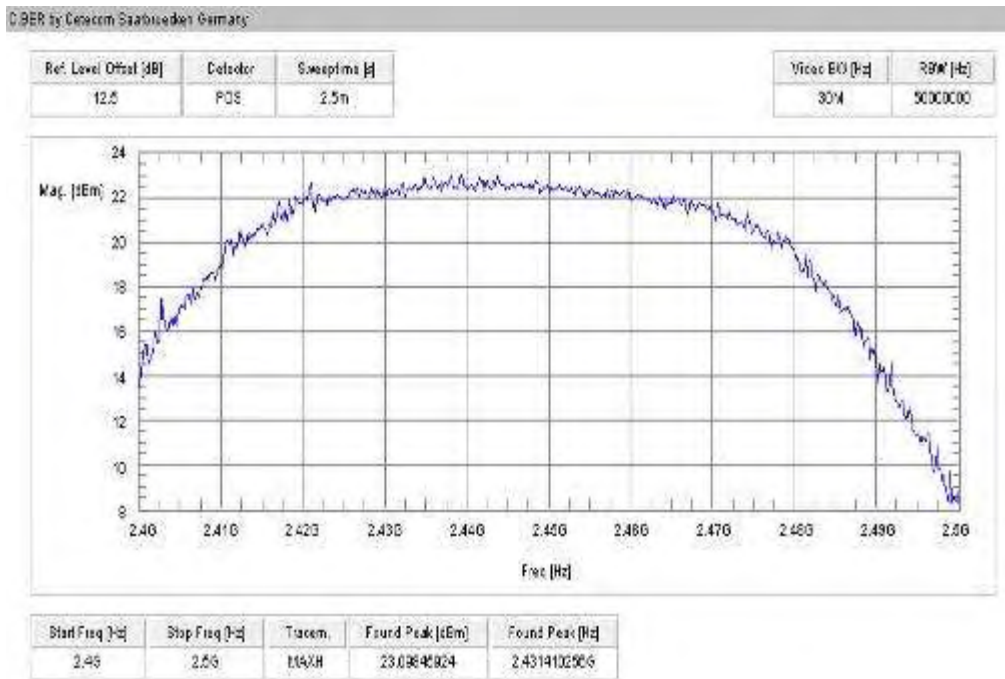

Plot 6: TX mode, middle channel, MCS 5

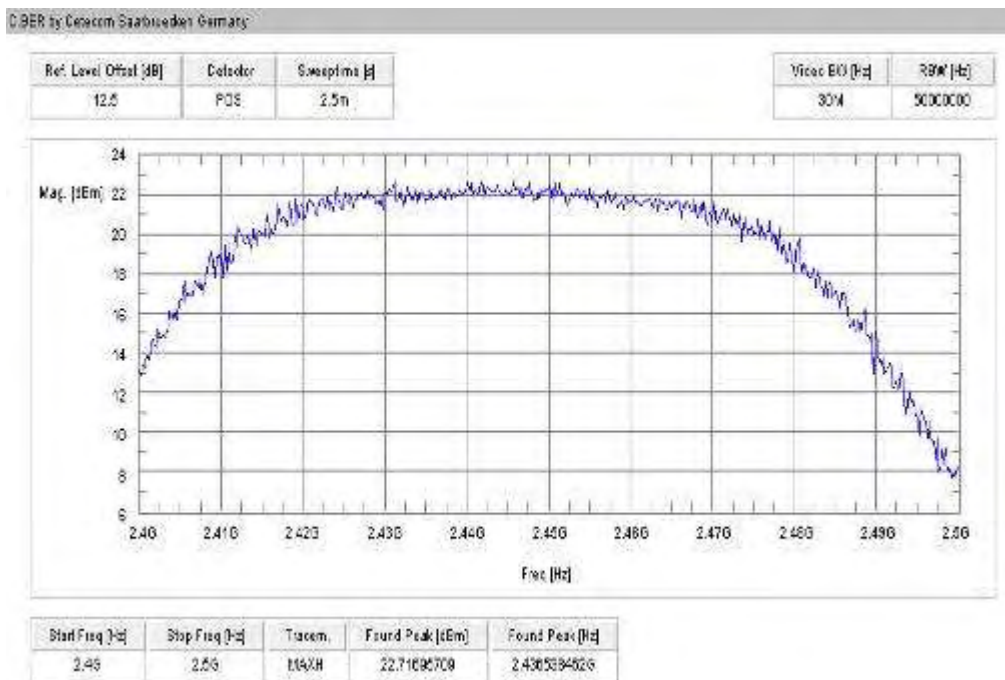

Plot 7: TX mode, middle channel, MCS 6

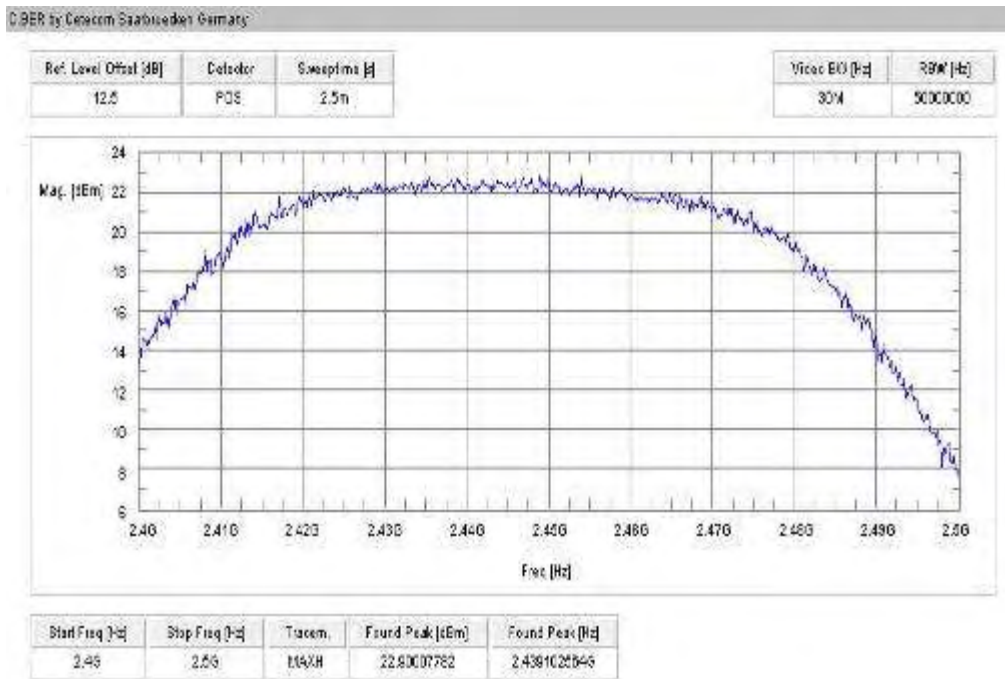

Plot 8: TX mode, middle channel, MCS 7

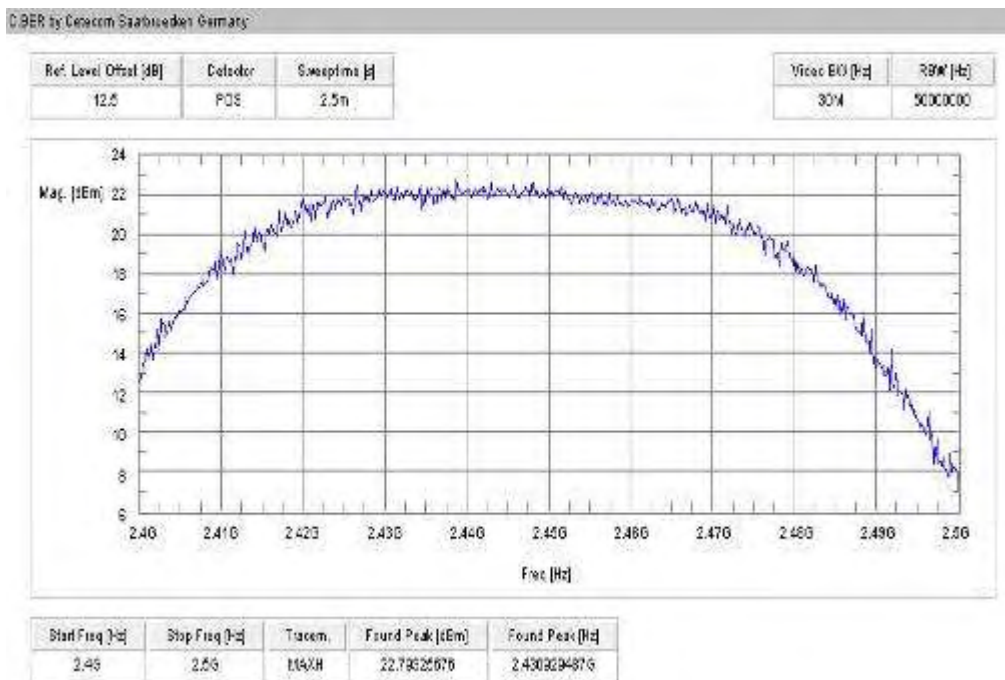

9.2 Antenna gain

Measurement:

The antenna gain of the complete system is calculated by the difference of radiated power in EIRP and the conducted power of the module. For normal WLAN devices, the DSSS mode is used.

Measurement parameters:

Measurement parameter	
Detector:	Peak
Sweep time:	Auto
Video bandwidth:	3 MHz
Resolution bandwidth:	3 MHz
Span:	30 MHz
Trace-Mode:	Max hold

Limits:

FCC	IC
CFR Part 15.247 (b)(4)	RSS 210, Issue 8, A 8.4(2)
Antenna Gain	
6 dBi	

Results:

T _{nom}	V _{nom}	lowest channel 2412 MHz	middle channel 2437 MHz	highest channel 2462 MHz
Conducted power [dBm] Measured with DSSS modulation		19.58	18.84	18.83
Radiated power [dBm] Measured with DSSS modulation		16.85	15.63	16.36
Gain [dBi] Calculated		-2.73	-3.21	-2.47

Result: The result of the measurement is passed.

Plots: DSSS / b – mode

Plot 1: lowest channel

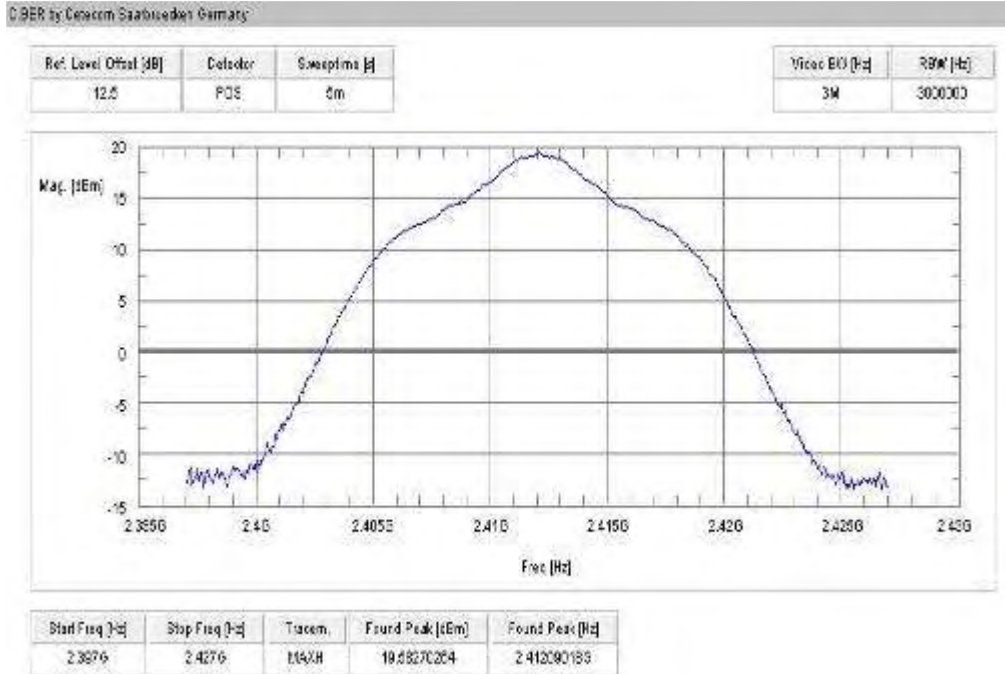

Plot 2: middle channel

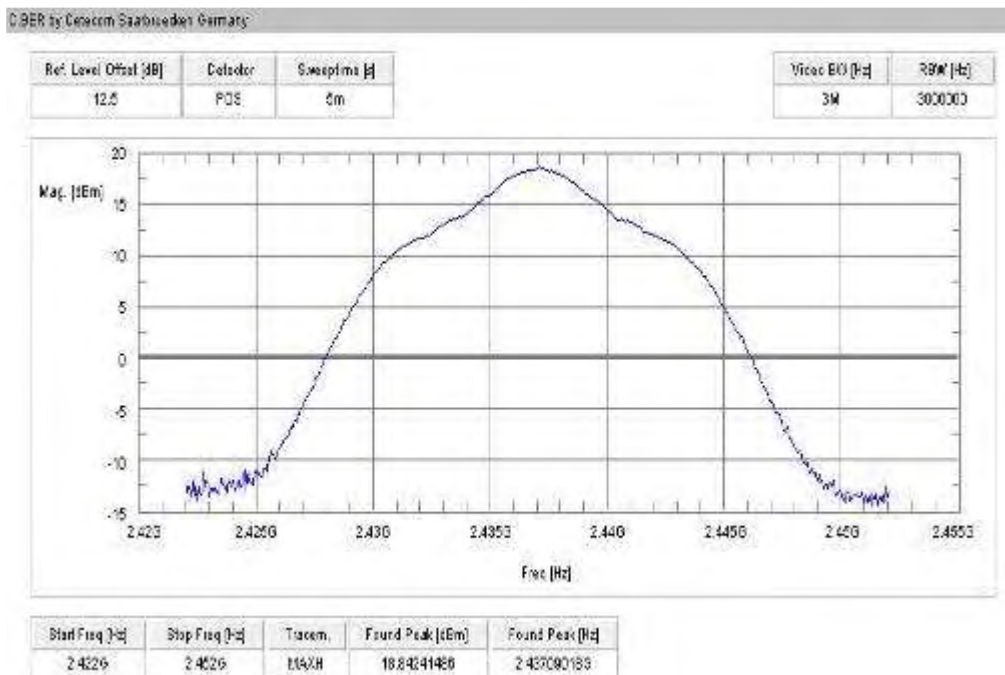

Plot 3: highest channel

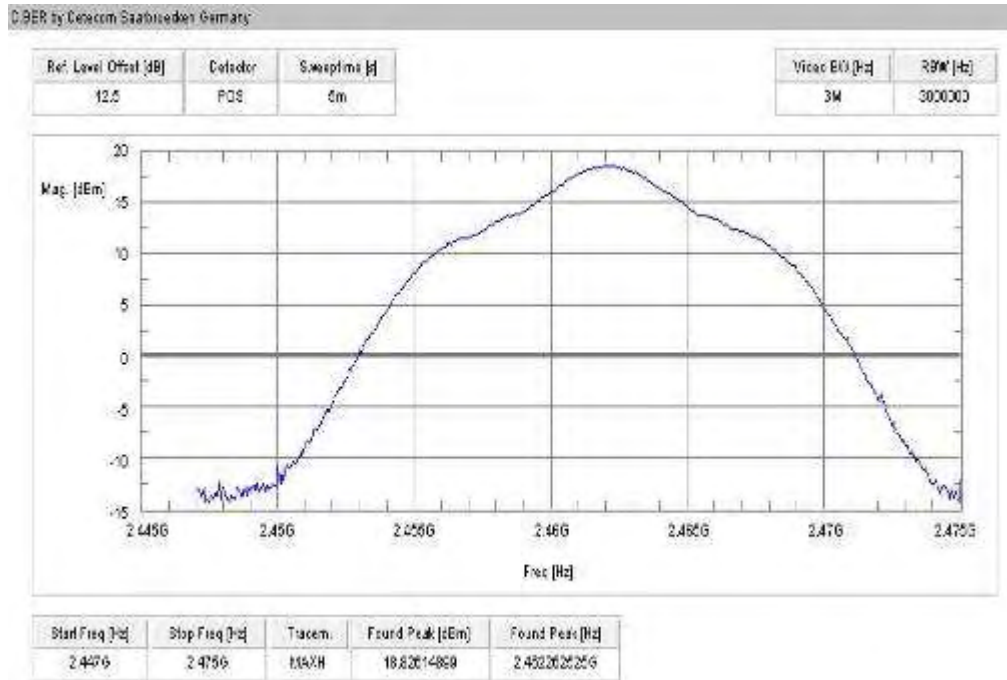

9.3 Power spectral density

Description:

Measurement of the power spectral density of a digital modulated system. The measurement is repeated for both modulations at the lowest, middle and highest channel.

Measurement:

Measurement parameter	
Detector:	Peak
Sweep time:	500 s
Video bandwidth:	3 kHz
Resolution bandwidth:	3 kHz
Span:	1.5 MHz
Trace-Mode:	Max Hold

Limits:

FCC	IC
CFR Part 15.247 (e)	RSS 210, Issue 8, A 8.2(b)
Power Spectral Density	
The transmitter power spectral density conducted from the transmitter to the antenna shall not be greater than 8 dBm in any 3 kHz band during any time interval of continuous transmission or over 1.0 second if the transmission exceeds 1.0-second duration.	

Results:

Modulation Frequency	Power Spectral density [dBm/3kHz]		
	2412 MHz	2437 MHz	2462 MHz
DSSS / b – mode	-3.81	-4.88	-2.90
OFDM / g – mode	-7.68	-7.33	-7.83
OFDM / n – mode	-7.53	-7.71	-7.81
Measurement uncertainty	± 0.5 dB		

Result: **The result of the measurement is passed.**

Plots: DSSS / b – mode

Plot 1: TX mode, lowest channel

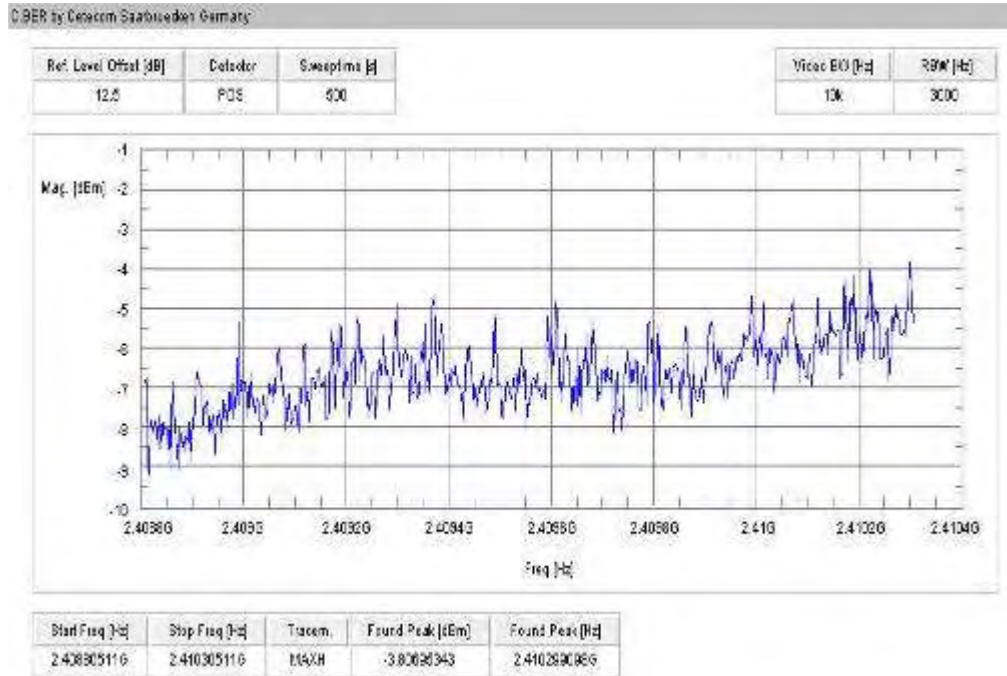

Plot 2: TX mode, middle channel

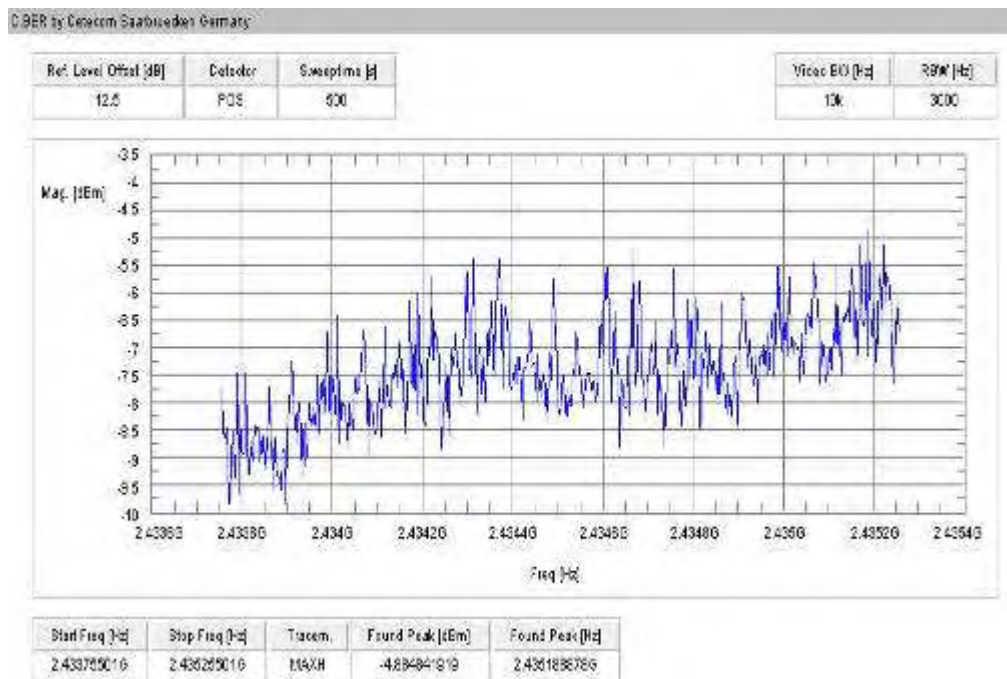

Plot 3: TX mode, highest channel

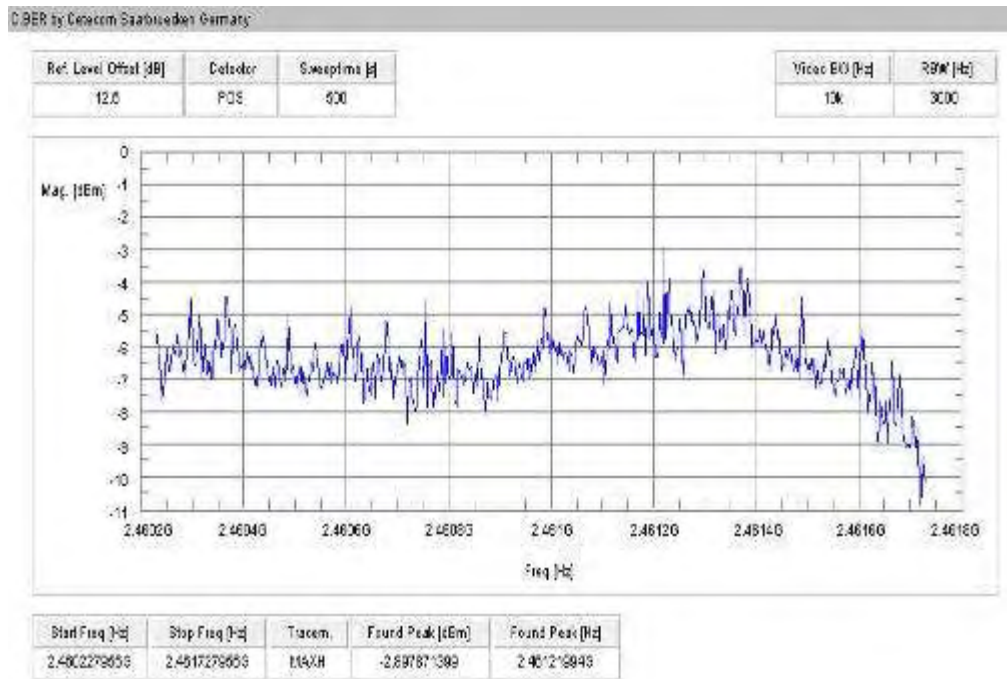

Plots: OFDM / q – mode

Plot 1: TX mode, lowest channel

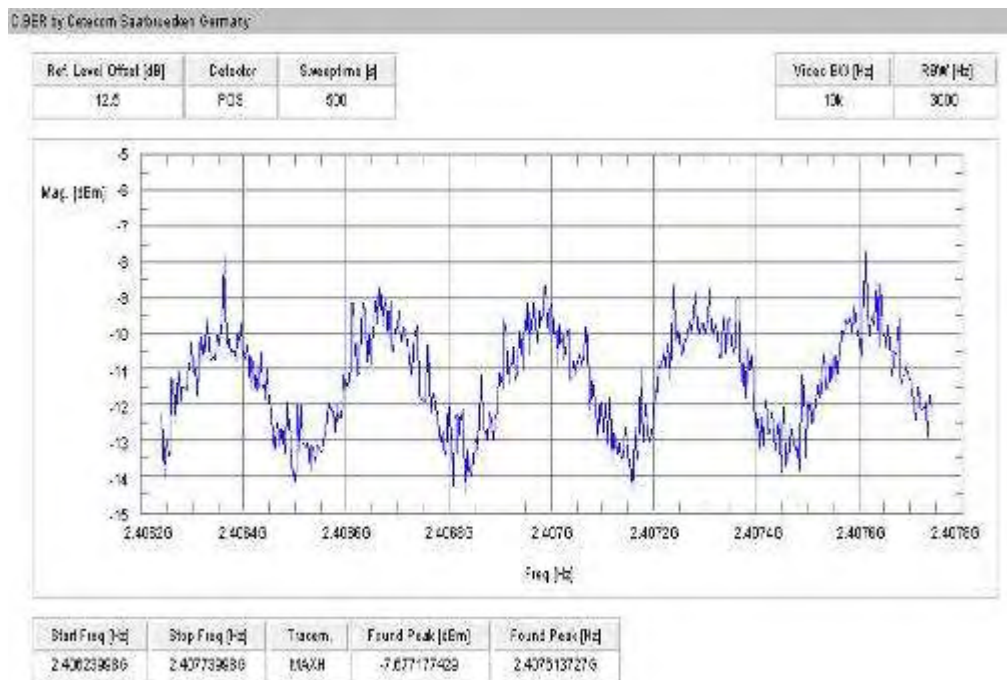

Plot 2: TX mode, middle channel

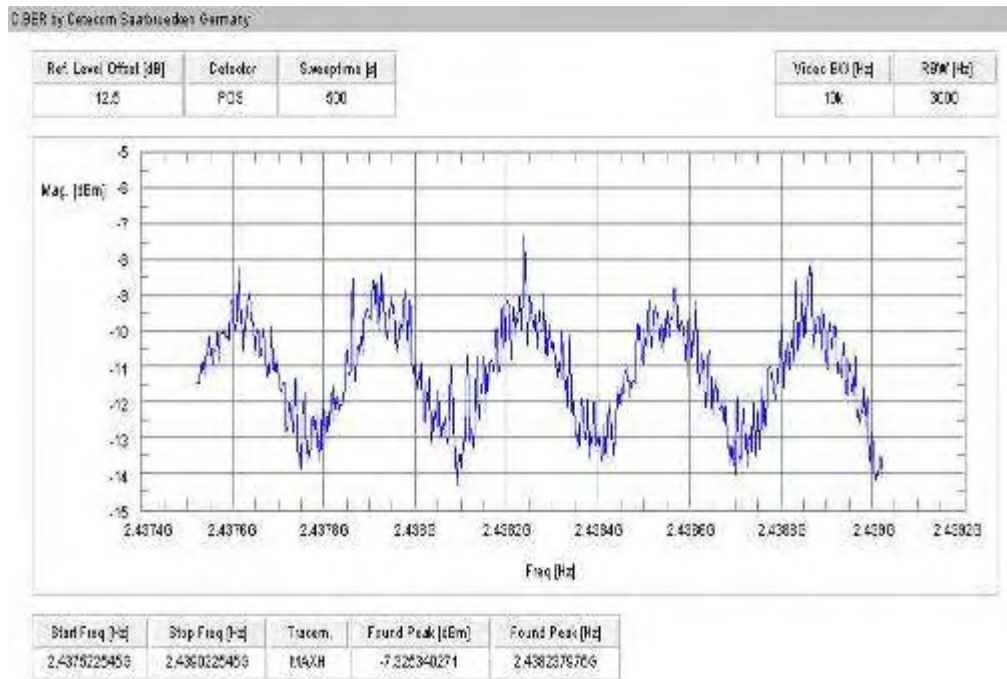

Plot 3: TX mode, highest channel

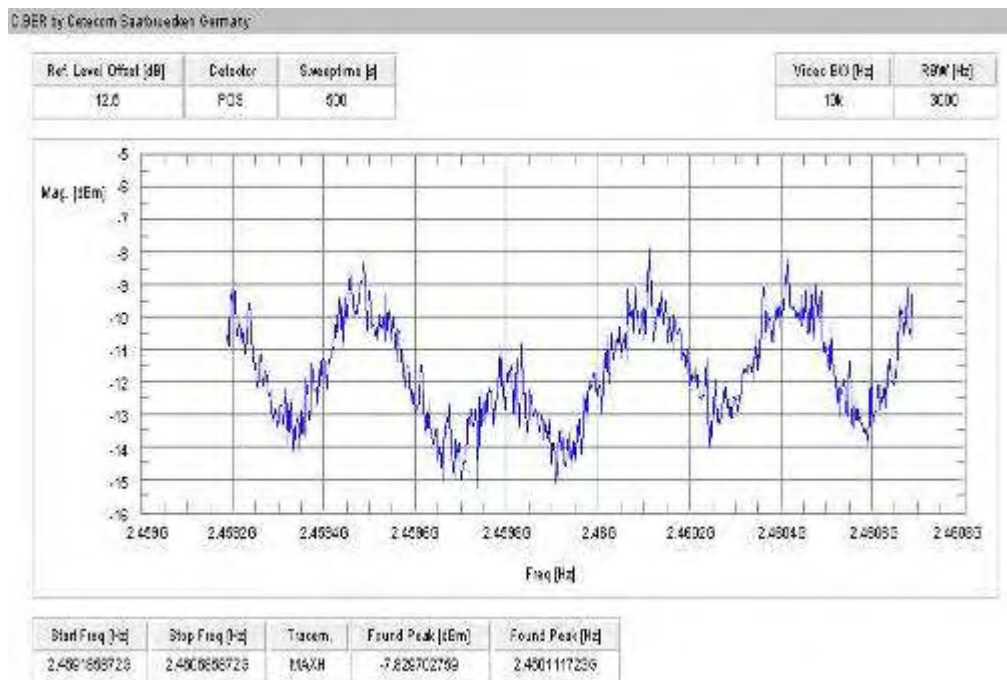

Plots: OFDM / n – mode

Plot 1: TX mode, lowest channel

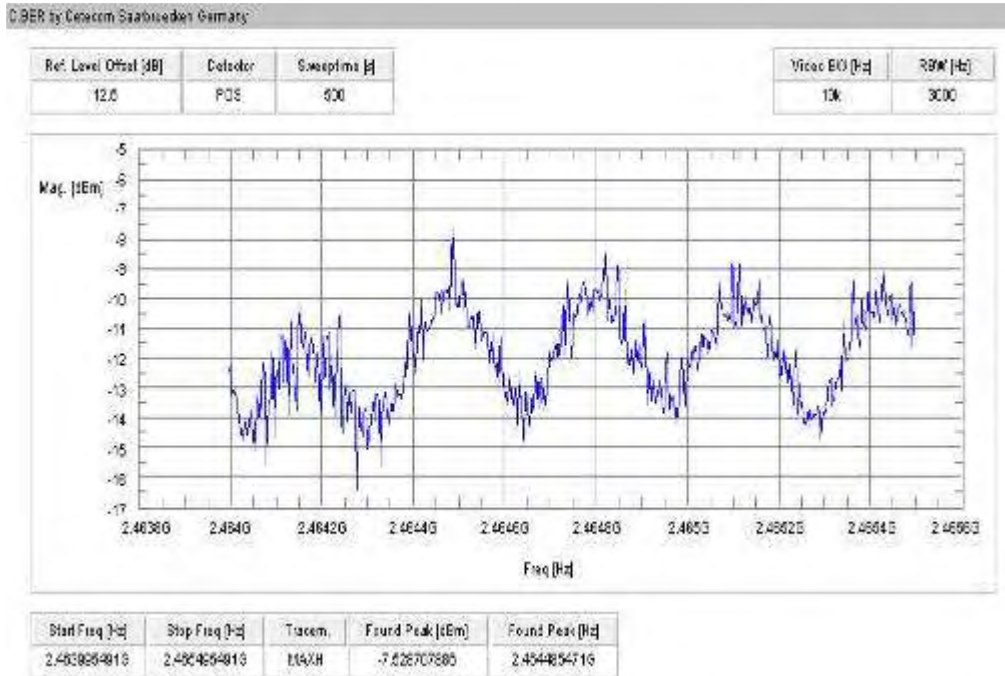

Plot 2: TX mode, middle channel

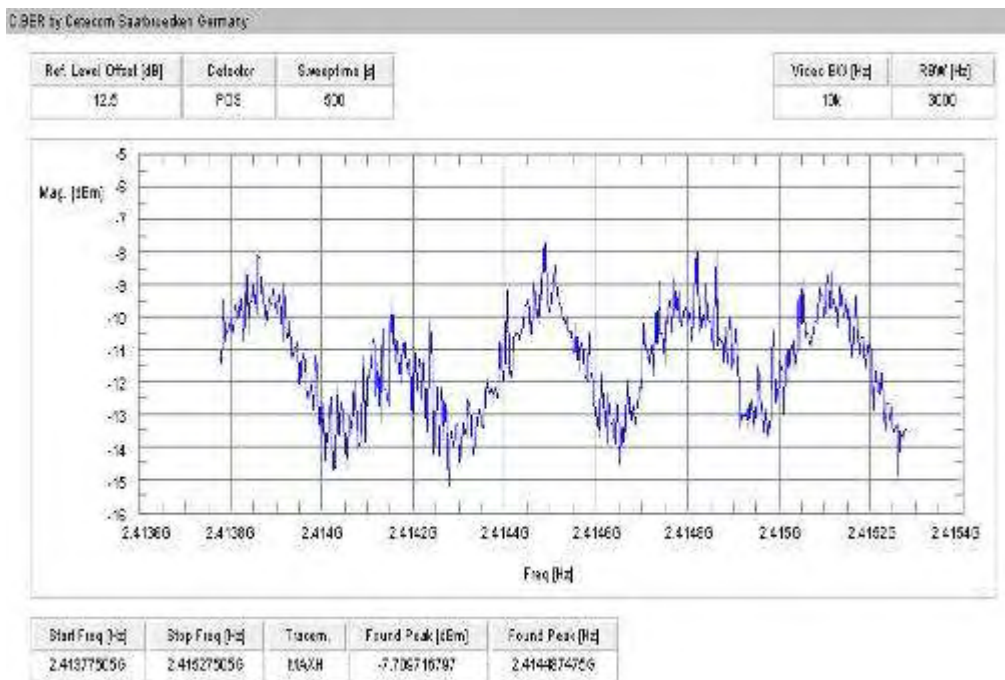

Plot 3: TX mode, highest channel

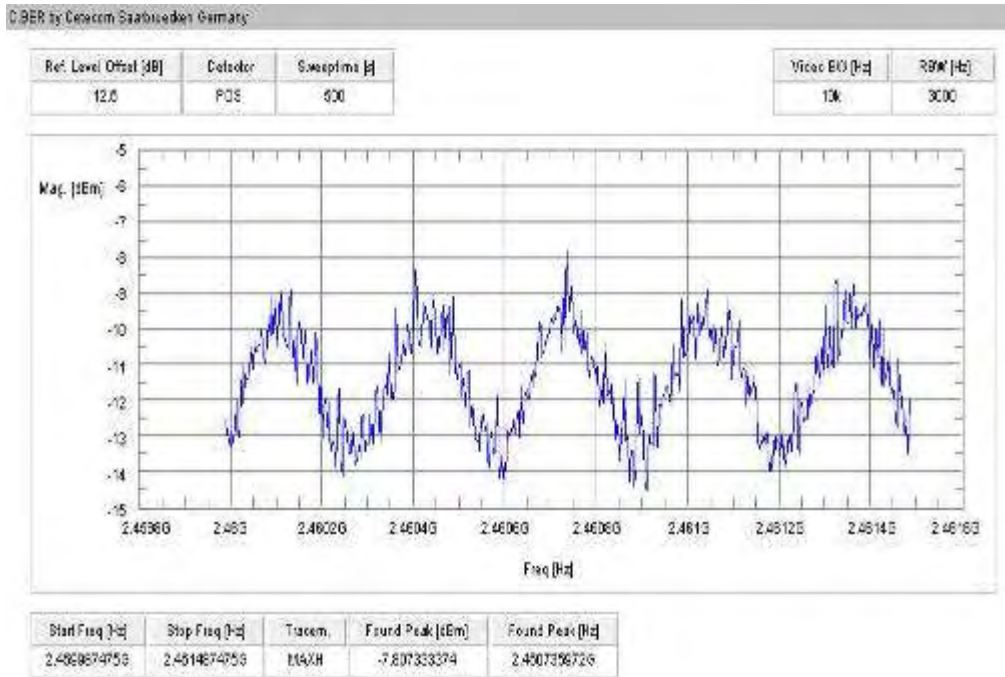

9.4 Spectrum bandwidth of a FHSS system – 6 dB bandwidth

Description:

Measurement of the 6 dB bandwidth of the modulated signal.

Measurement:

Measurement parameter	
Detector:	Peak
Sweep time:	Auto
Video bandwidth:	100 kHz
Resolution bandwidth:	100 kHz
Span:	30 MHz
Trace-Mode:	Max Hold

Limits:

FCC	IC
CFR Part 15.247 (a)(2)	RSS 210, Issue 8, A 8.2(a)
Spectrum Bandwidth of a FHSS System – 6 dB Bandwidth	
Systems using digital modulation techniques may operate in the 2400–2483.5 MHz band. The minimum 6 dB bandwidth shall be at least 500 kHz.	

Results:

Modulation Frequency	6 dB BANDWIDTH [MHz]		
	2412 MHz	2437 MHz	2462 MHz
DSSS / b – mode	9.08	8.00	9.08
OFDM / g – mode	16.11	15.45	15.51
OFDM / n – mode	17.56	15.99	15.63
Measurement uncertainty	± 100 kHz		

Result: The result of the measurement is passed.

Plots: DSSS / b – mode

Plot 1: TX mode, lowest channel, 6 dB bandwidth

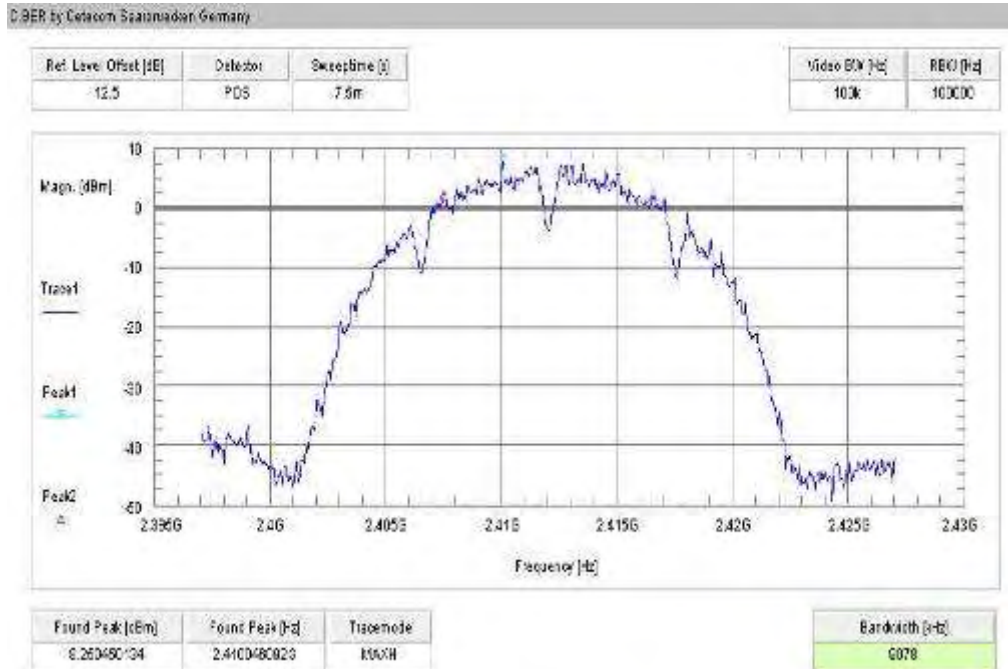

Plot 2: TX mode, middle channel, 6 dB bandwidth

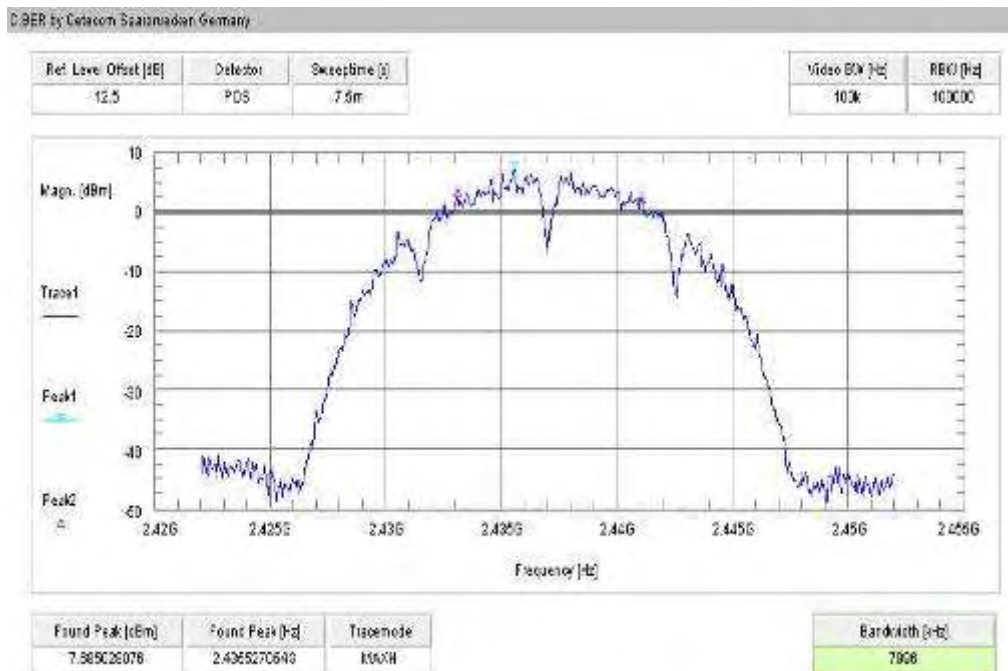

Plot 3: TX mode, highest channel, 6 dB bandwidth

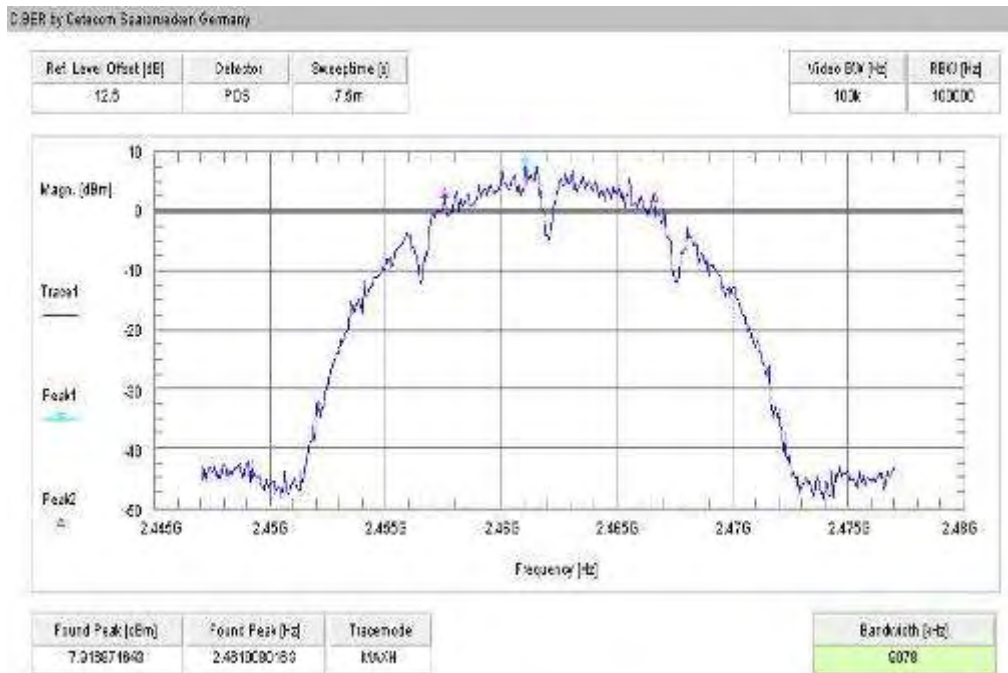

Plots: OFDM / g – mode

Plot 1: TX mode, lowest channel, 6 dB bandwidth

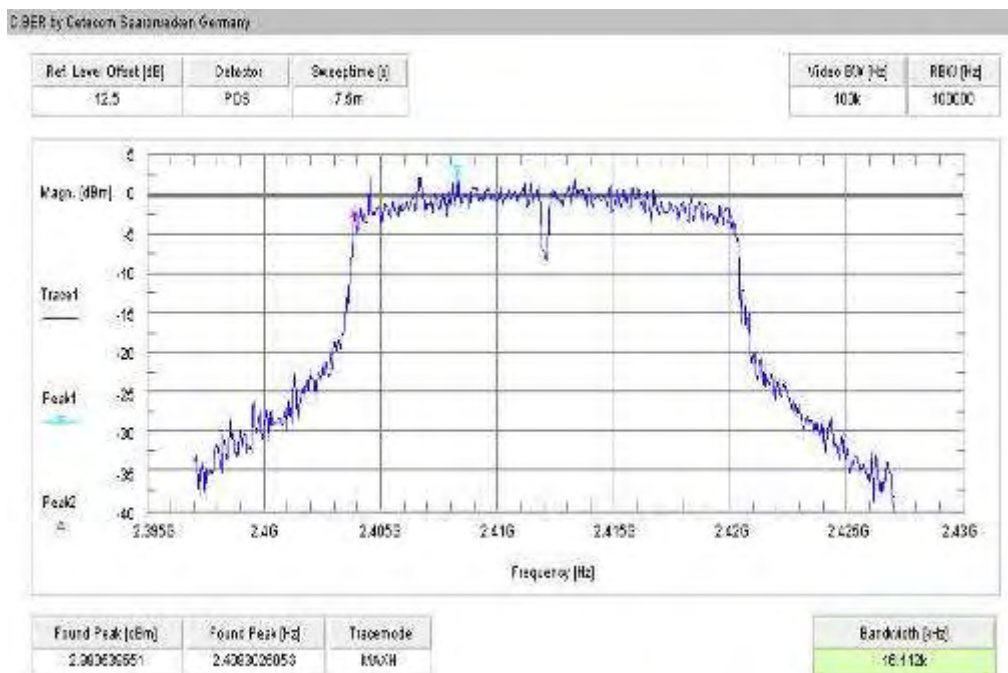

Plot 2: TX mode, middle channel, 6 dB bandwidth

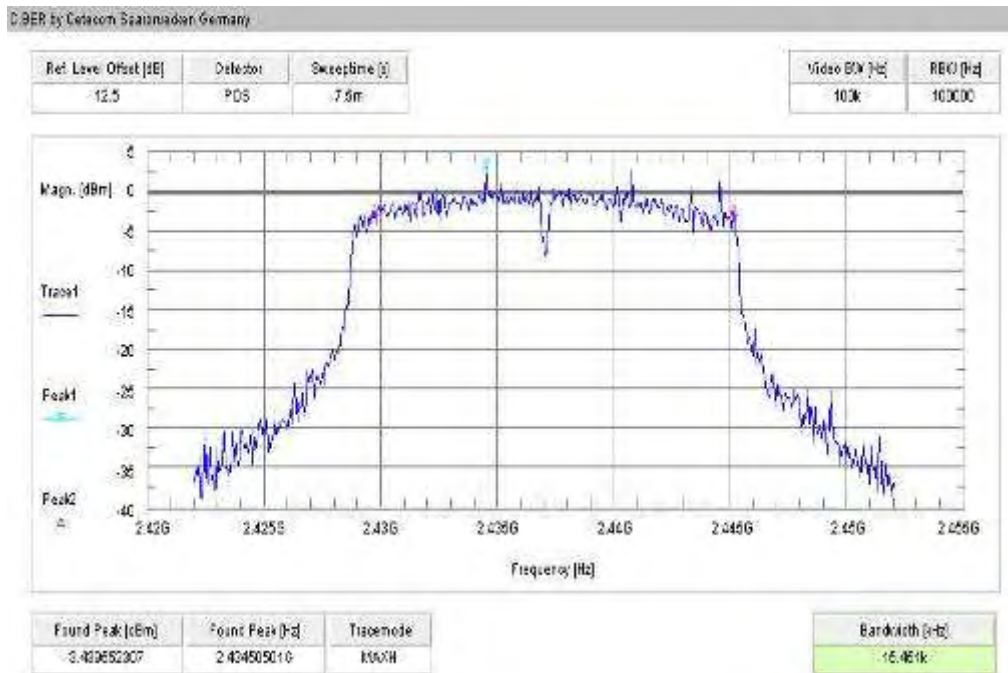

Plot 3: TX mode, highest channel, 6 dB bandwidth

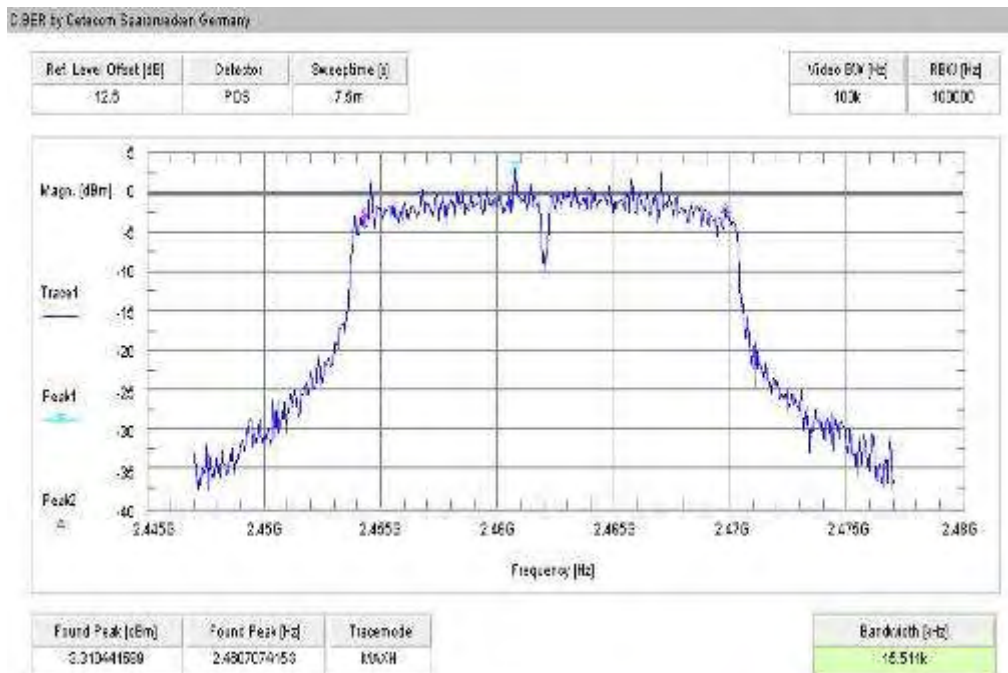

Plots: OFDM / n – mode

Plot 1: TX mode, lowest channel, 6 dB bandwidth

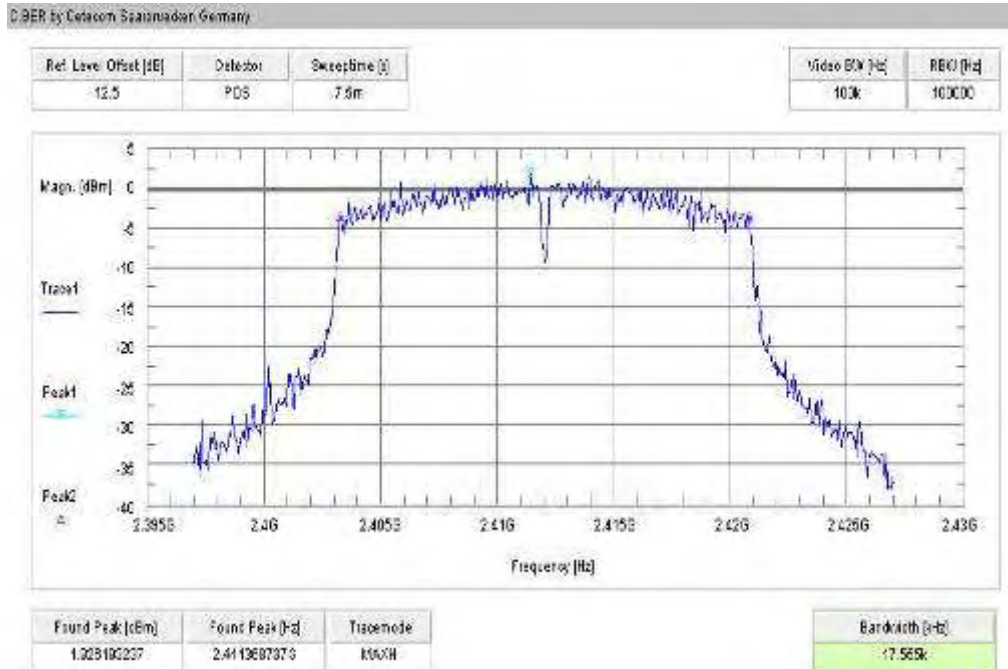

Plot 2: TX mode, middle channel, 6 dB bandwidth

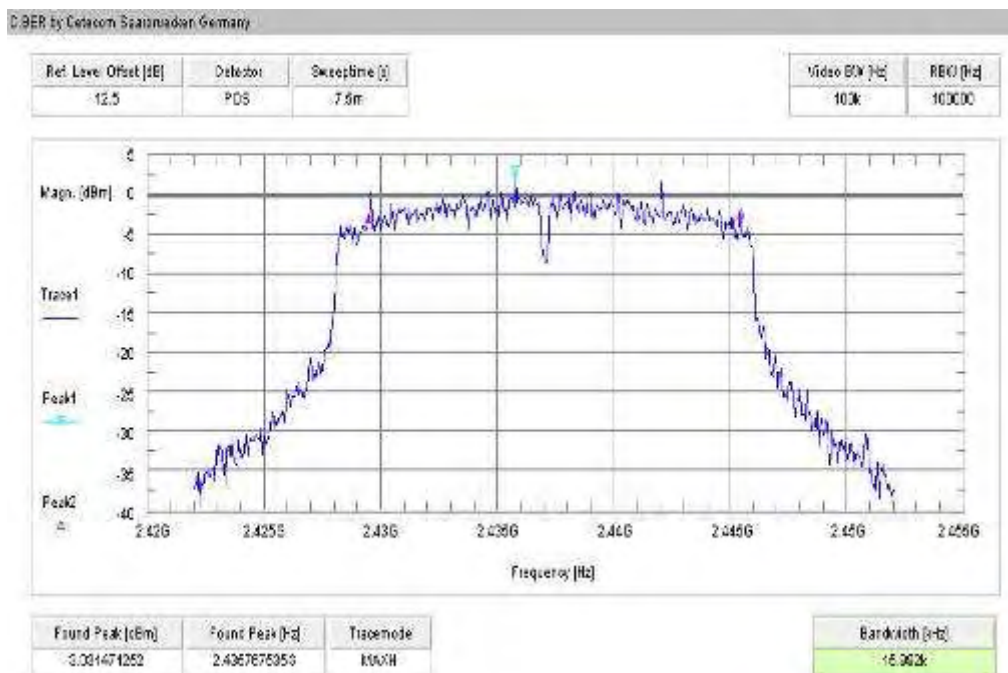

Plot 3: TX mode, highest channel, 6 dB bandwidth

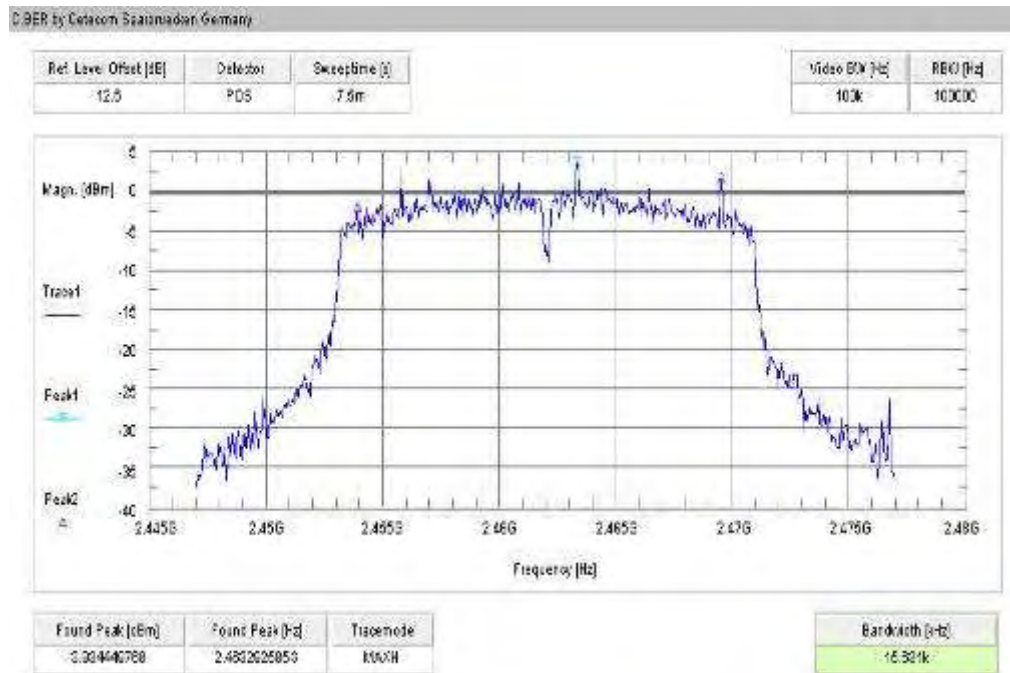

9.5 Spectrum bandwidth of a FHSS system – 20 dB bandwidth

Description:

Measurement of the 20 dB bandwidth of the modulated signal.

Measurement:

Measurement parameter	
Detector:	Peak
Sweep time:	Auto
Video bandwidth:	100 kHz
Resolution bandwidth:	100 kHz
Span:	30 MHz
Trace-Mode:	Max Hold

Limits:

FCC	IC
CFR Part 15.247 (a)(2)	RSS 210, Issue 8, A 8.2(a)
Spectrum Bandwidth of a FHSS System – 20 dB Bandwidth	
Systems using digital modulation techniques may operate in the 2400–2483.5 MHz band. The minimum 6 dB bandwidth shall be at least 500 kHz.	

Results:

Modulation Frequency	20 dB BANDWIDTH [MHz]		
	2412 MHz	2437 MHz	2462 MHz
DSSS / b – mode	15.09	15.03	15.57
OFDM / g – mode	17.56	17.80	17.98
OFDM / n – mode	18.58	18.88	18.58
Measurement uncertainty	± 100 kHz		

Result: The result of the measurement is passed.

Plots: DSSS / b – mode

Plot 1: TX mode, lowest channel, 20 dB bandwidth

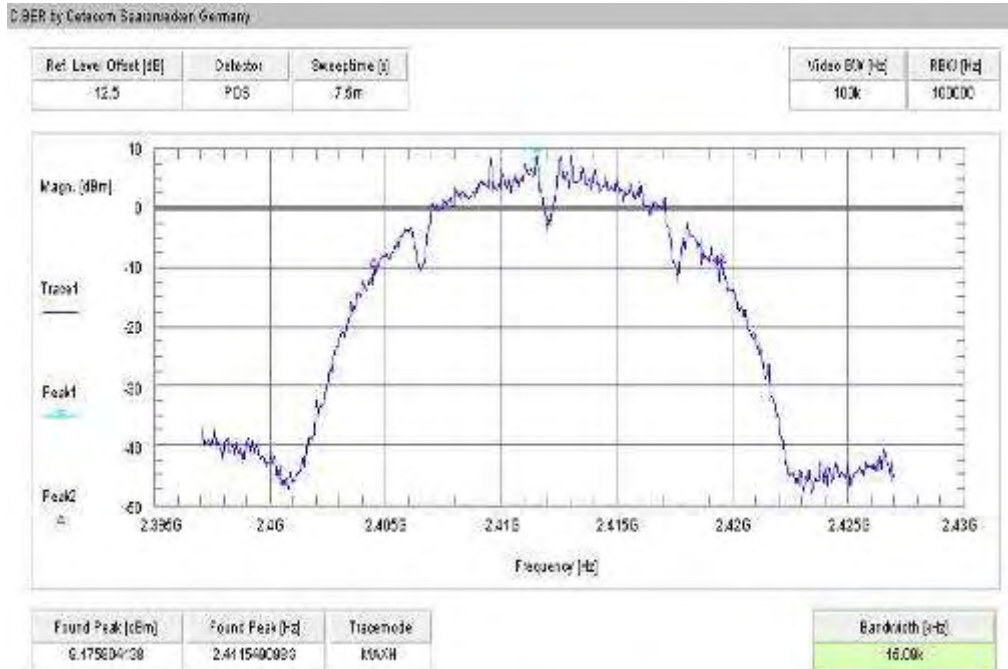

Plot 2: TX mode, middle channel, 20 dB bandwidth

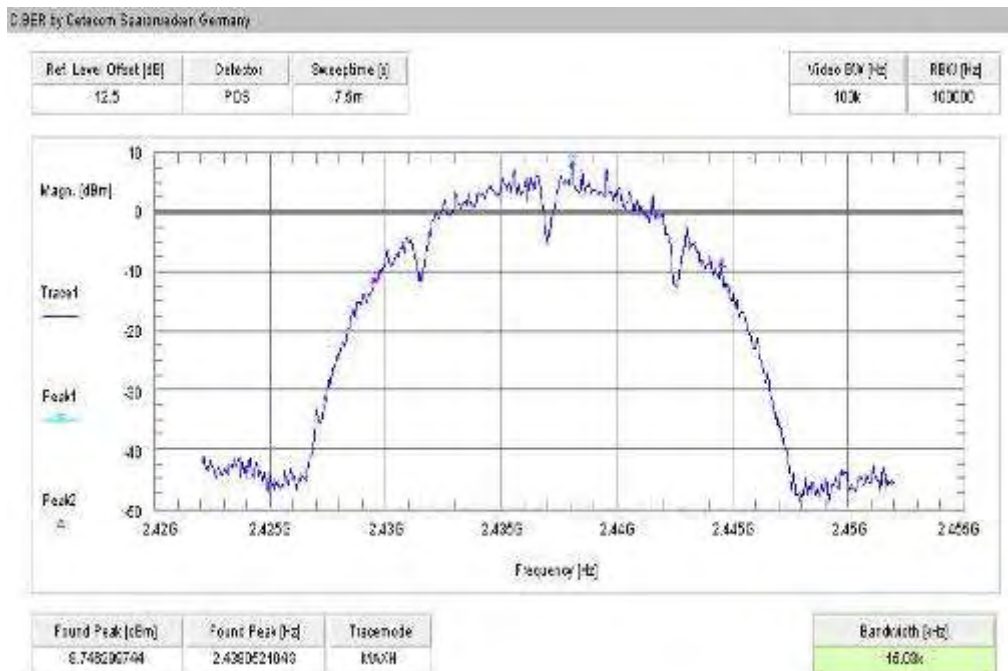

Plot 3: TX mode, highest channel, 20 dB bandwidth

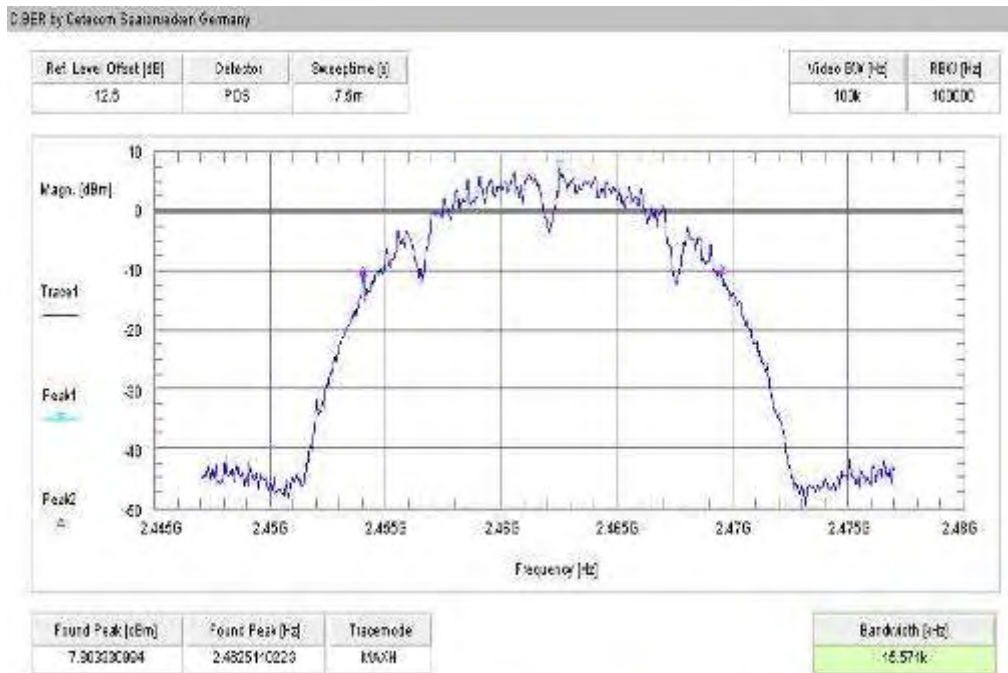

Plots: OFDM / g – mode

Plot 1: TX mode, lowest channel, 20 dB bandwidth

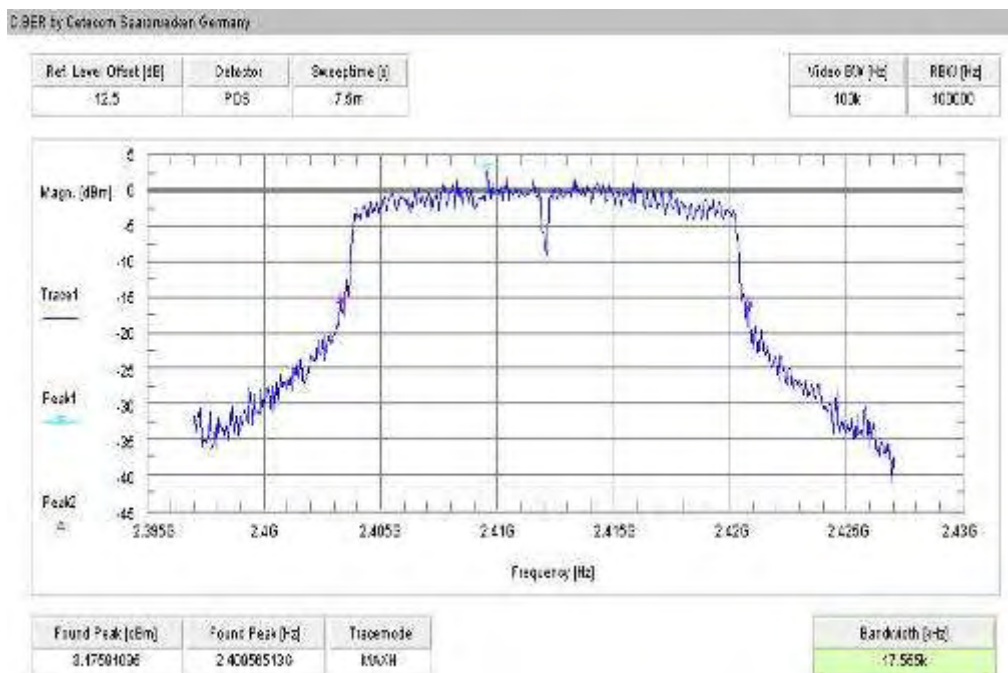

Plot 2: TX mode, middle channel, 20 dB bandwidth

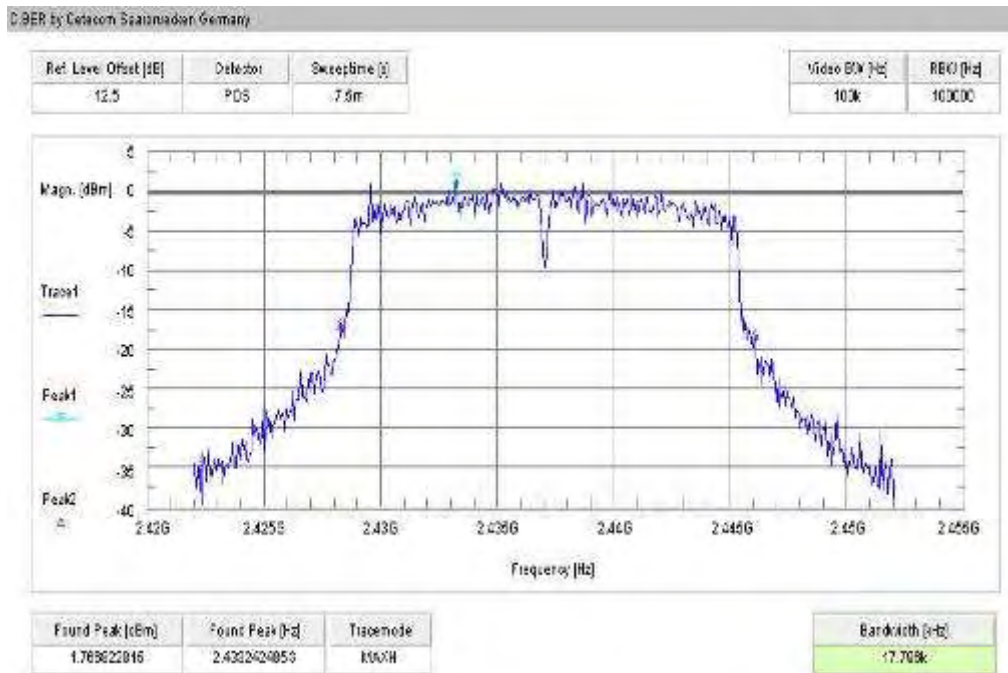

Plot 3: TX mode, highest channel, 20 dB bandwidth

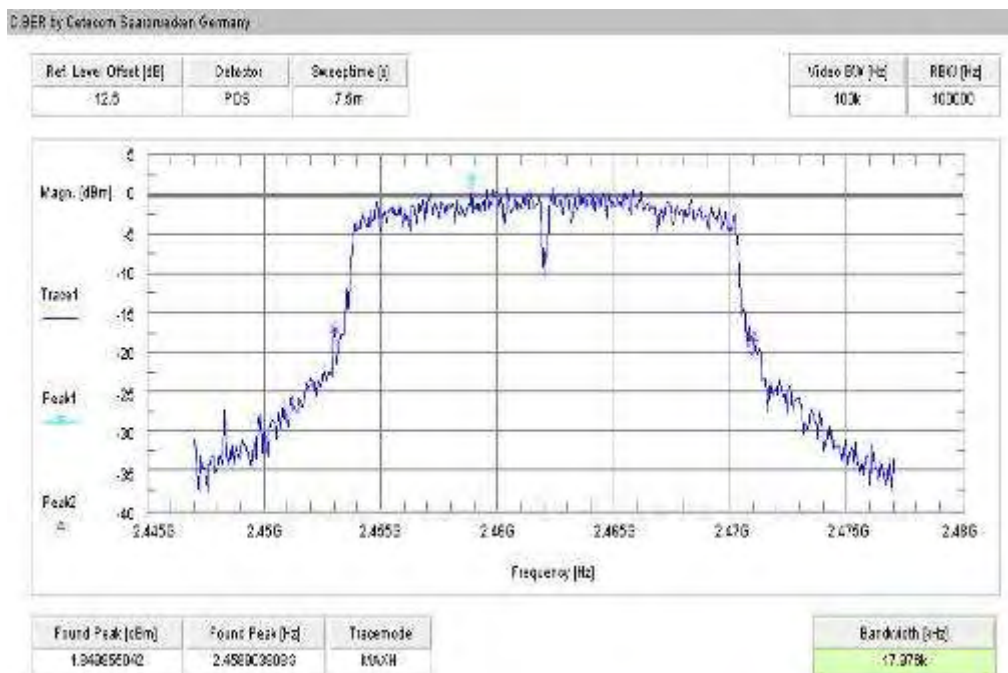

Plots: OFDM / n – mode

Plot 1: TX mode, lowest channel, 20 dB bandwidth

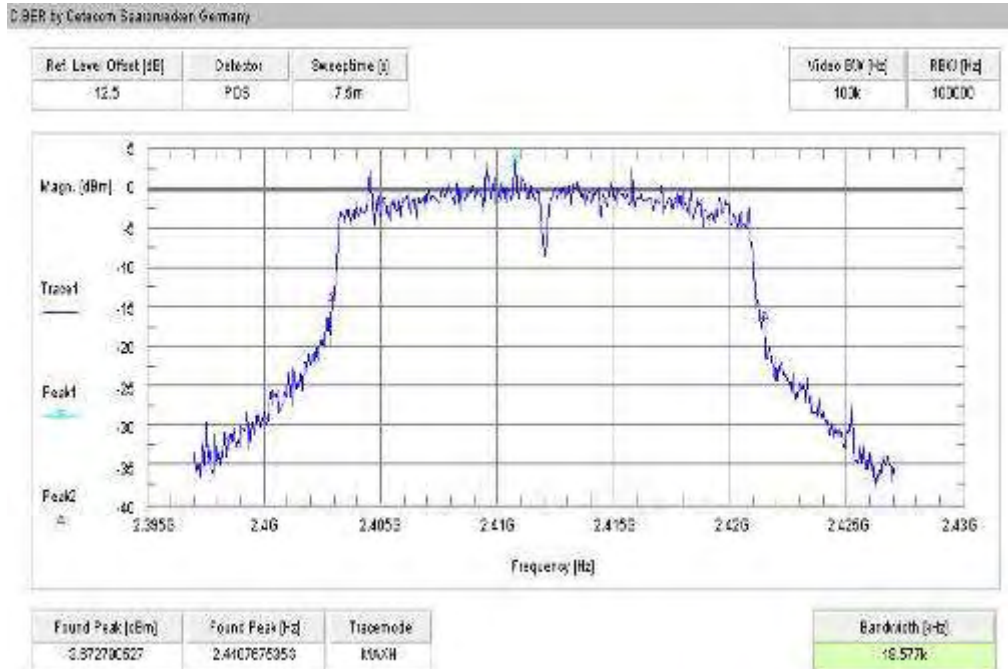

Plot 2: TX mode, middle channel, 20 dB bandwidth

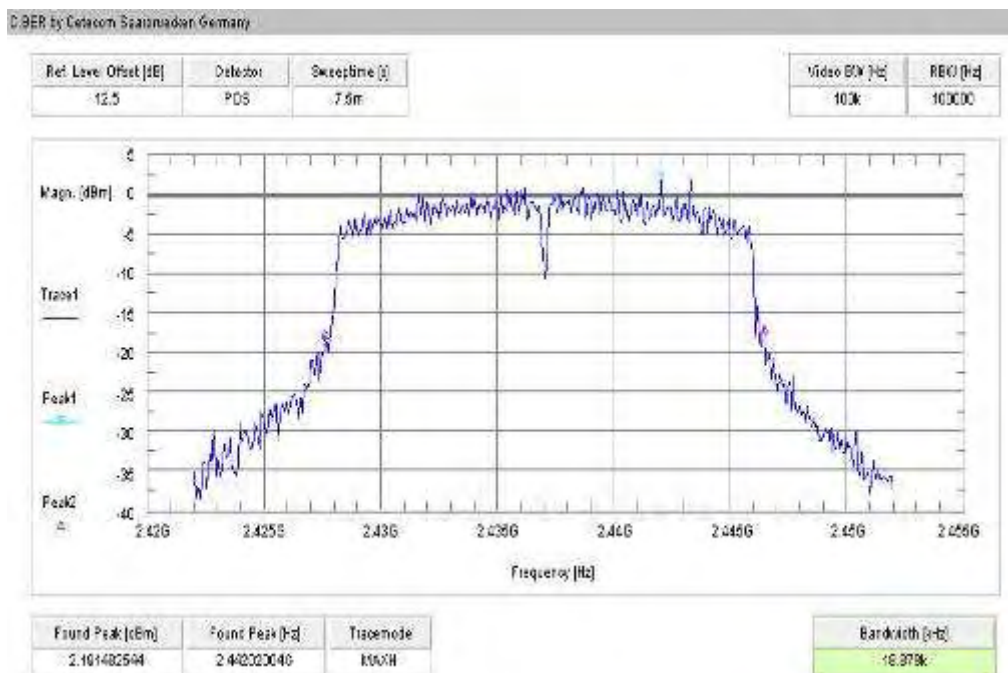

Plot 3: TX mode, highest channel, 20 dB bandwidth

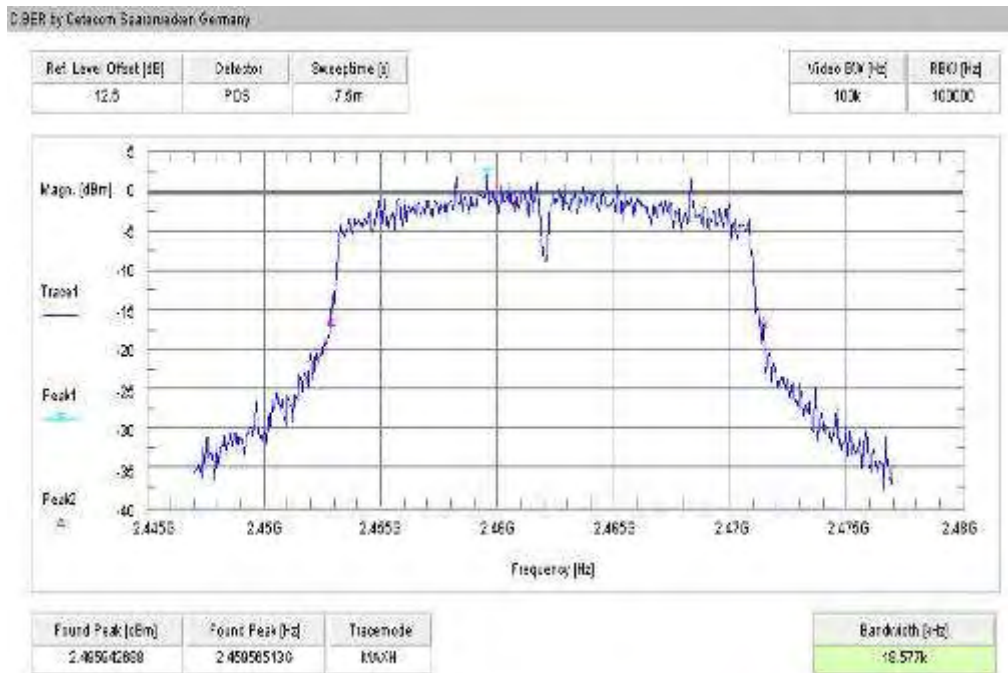

9.6 Maximum output power

Description:

Measurement of the maximum output power conducted and radiated. The measurements are performed using the data rate producing the highest conducted output power. The determination of these data rates was performed at the beginning of the tests. Additionally the average power is measured using a wideband power meter.

Measurement:

Measurement parameter	
Detector:	Peak
Sweep time:	Auto
Video bandwidth:	30 MHz
Resolution bandwidth:	50 MHz
Span:	30 MHz
Trace-Mode:	Max Hold

Limits:

FCC	IC
CFR Part 15.247 (b)(3)	RSS 210, Issue 8, A 8.4(4)
Maximum Output Power	
Conducted: 1.0 W – Antenna Gain max. 6 dBi	

Results: DSSS / b – mode

DSSS / b – mode Frequency	Maximum Output Power [dBm]		
	2412 MHz	2437 MHz	2462 MHz
Peak Output Power Conducted	19.85	18.84	18.83
Output Power Radiated - EIRP	17.12	15.63	16.36
Measurement uncertainty	± 0.5 dB (cond.) / ± 2 dB (rad.)		

Result: The result of the measurement is passed.

Results: OFDM / g – mode

OFDM / g – mode Frequency	Maximum Output Power [dBm]		
	2412 MHz	2437 MHz	2462 MHz
Peak Output Power Conducted	23.47	23.37	23.80
Output Power Radiated - EIRP	20.74	20.16	21.33
Measurement uncertainty	± 0.5 dB (cond.) / ± 2 dB (rad.)		

Result: The result of the measurement is passed.

Results: OFDM / n – mode

OFDM / n – mode Frequency	Maximum Output Power [dBm]		
	2412 MHz	2437 MHz	2462 MHz
Peak Output Power Conducted	23.34	23.25	23.85
Output Power Radiated - EIRP	20.61	20.04	21.38
Measurement uncertainty	± 0.5 dB (cond.) / ± 2 dB (rad.)		

Result: The result of the measurement is passed.

9.7 Band edge compliance conducted

Description:

Measurement of the conducted band edge compliance. EUT is measured at the lower and upper band edge in both modes.

Measurement:

Measurement parameter	
Detector:	Peak
Sweep time:	Auto
Video bandwidth:	100 kHz
Resolution bandwidth:	100 kHz
Span:	Lower Band Edge: 2300 – 2425 MHz Upper Band Edge: 2450 – 2500 MHz
Trace-Mode:	Max Hold

Limits:

FCC	IC
CFR Part 15.247 (d)	RSS 210, Issue 8, A 8.5
Band Edge Compliance Conducted	
<p>In any 100 kHz bandwidth outside the frequency band in which the spread spectrum or digitally modulated intentional radiator is operating, the radio frequency power that is produced by the intentional radiator shall be at least 20 dB below that in the 100 kHz bandwidth within the band that contains the highest level of the desired power, based on either an RF conducted or a radiated measurement. Attenuation below the general limits specified in Section 15.209(a) is not required.</p>	

Result:

Szenario Modulation	Band Edge Compliance Conducted [dB]	
	DSSS	OFDM
Lower Band Edge – Channel 1	> 20 dB (see plot 1)	> 20 dB (see plot 3)
Upper Band Edge – Channel 11	> 20 dB (see plot 2)	> 20 dB (see plot 4)
Measurement uncertainty	± 1.5 dB	

Result: The result of the measurement is passed.

Plots: DSSS / b – mode

Plot 1: TX mode, lower band edge

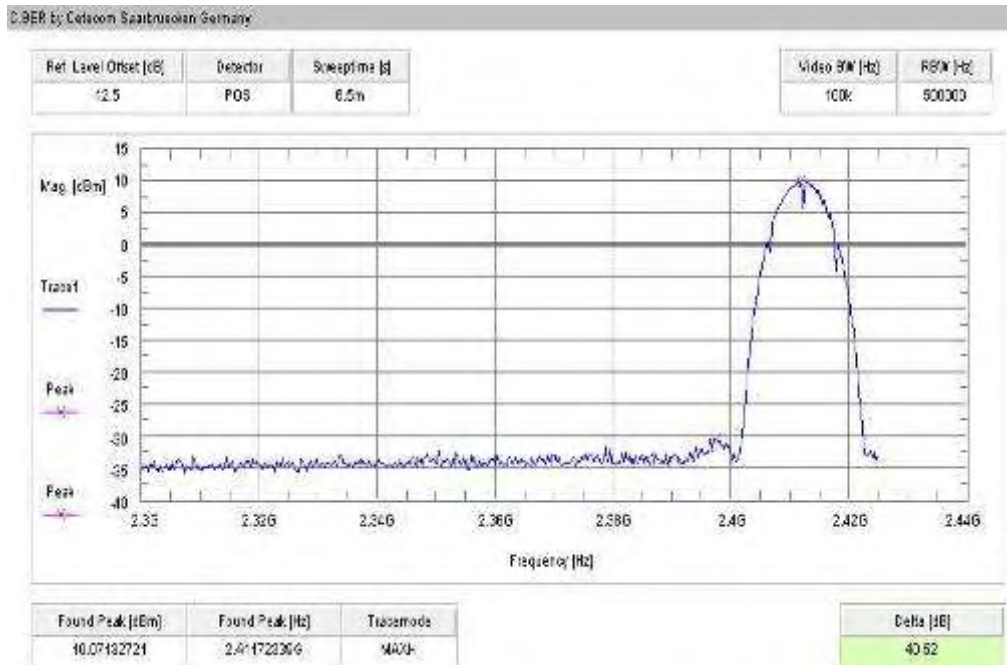

Plot 2: TX mode, upper band edge

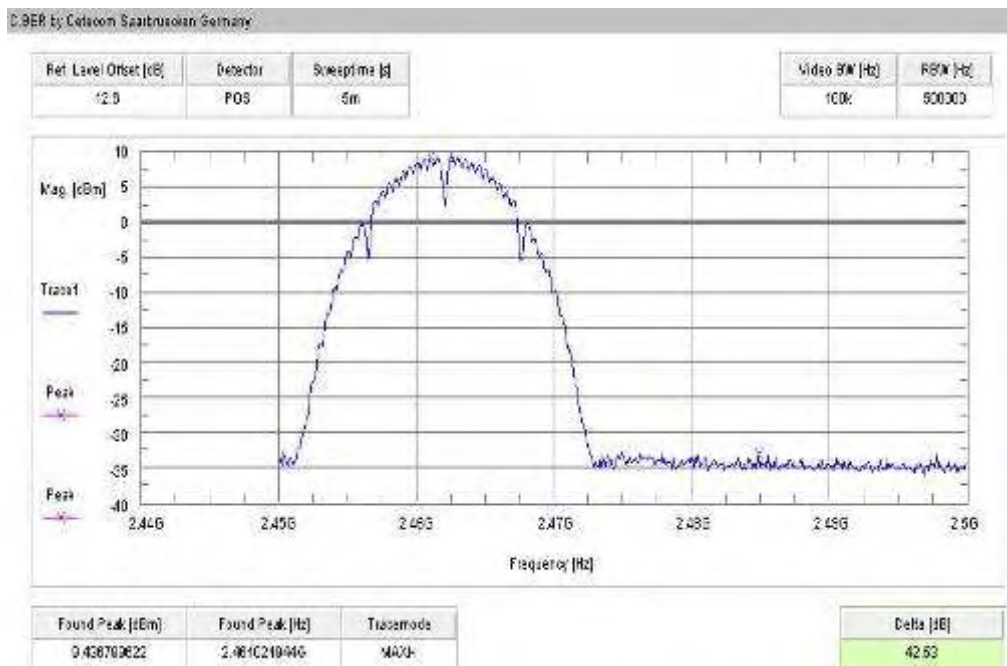

Plots: OFDM / g – mode

Plot 1: TX mode, lower band edge

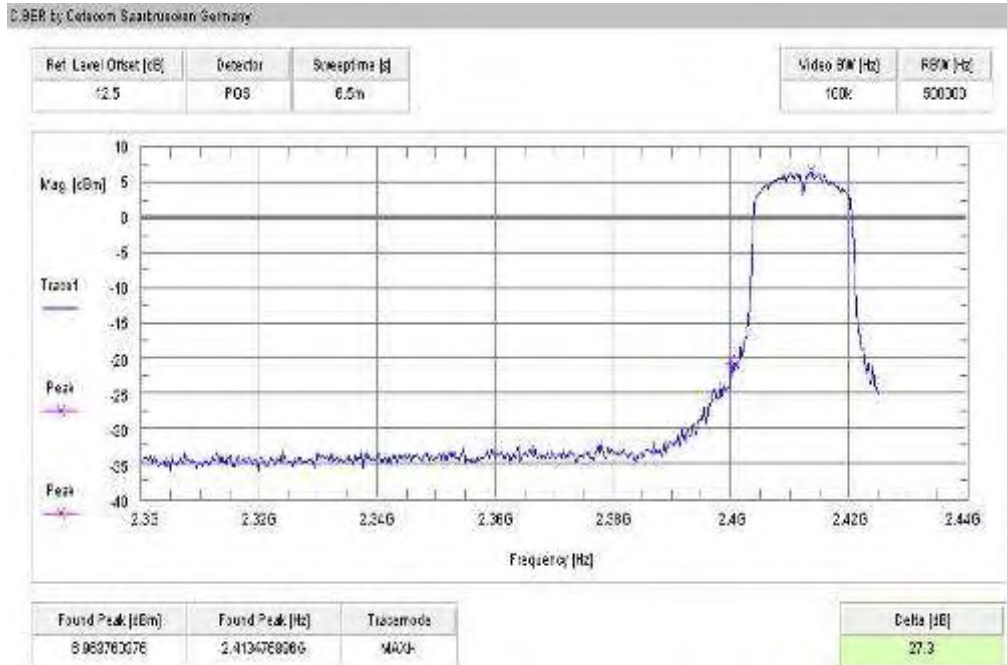

Plot 2: TX mode, upper band edge

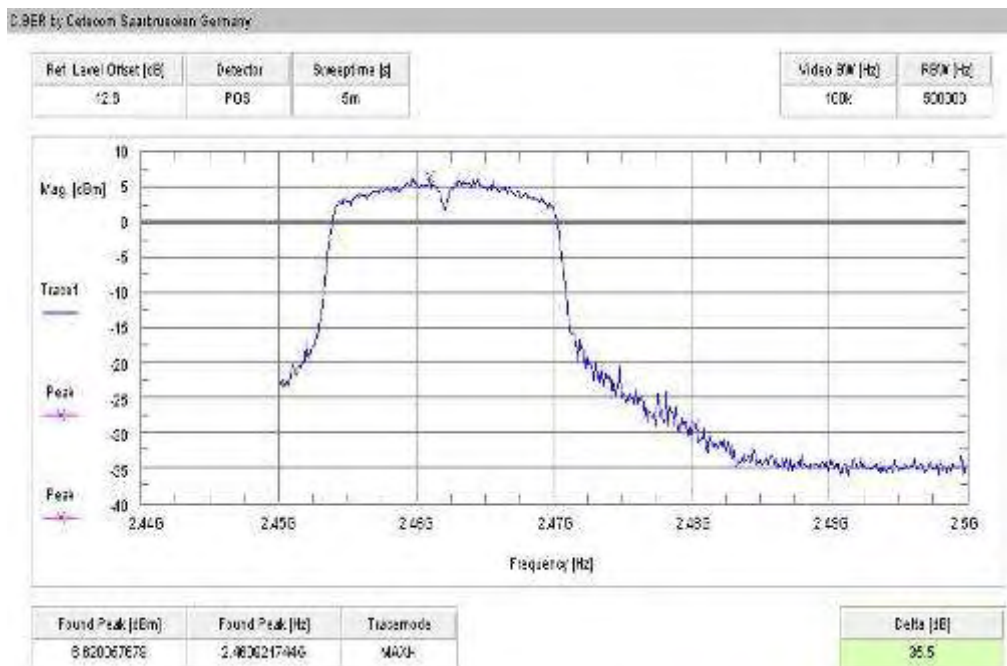

Plots: OFDM / n – mode

Plot 1: TX mode, lower band edge

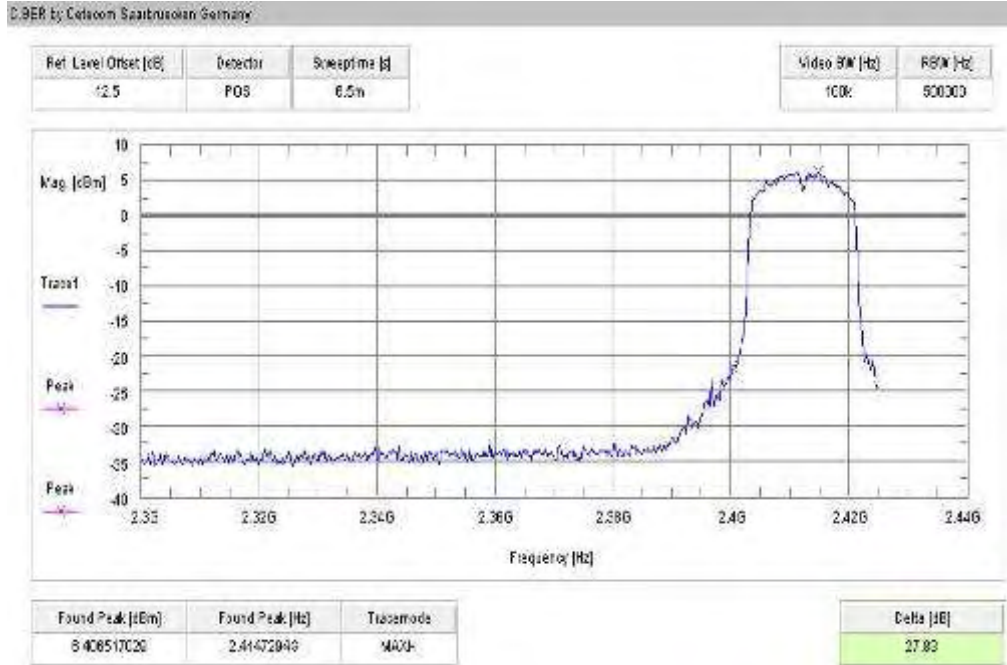

Plot 2: TX mode, upper band edge

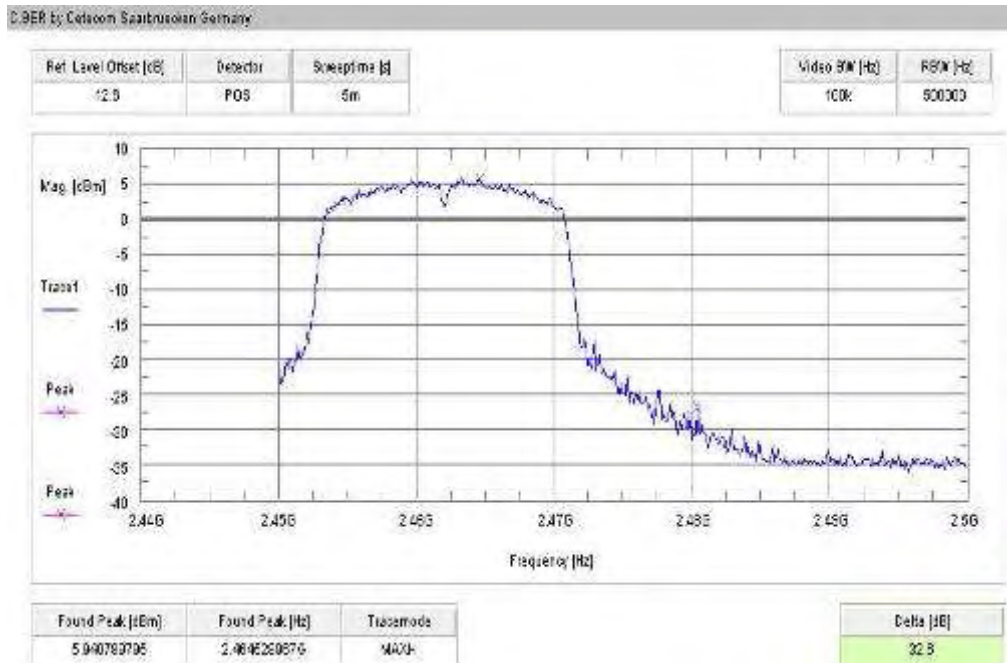

9.8 Band edge compliance radiated

Description:

Measurement of the radiated band edge compliance. The EUT is turned in the position that results in the maximum level at the band edge. Then a sweep over the corresponding restricted band is performed. The EUT is set to channel 1 for the lower restricted band and to channel 11 for the upper restricted band. The measurement is repeated for all modulations. Measurement distance is 3m.

Measurement:

Measurement parameter	
Detector:	Peak
Sweep time:	Auto
Video bandwidth:	10 Hz
Resolution bandwidth:	1 MHz
Span:	Lower Band: 2300 – 2400 MHz higher Band: 2480 – 2500 MHz
Trace-Mode:	Max Hold

Limits:

FCC	IC
CFR Part 15.205	RSS 210, Issue 8, A 8.5
Band Edge Compliance Radiated	
<p>In any 100 kHz bandwidth outside the frequency band in which the spread spectrum or digitally modulated intentional radiator is operating, the radio frequency power that is produced by the intentional radiator shall be at least 20 dB below that in the 100 kHz bandwidth within the band that contains the highest level of the desired power, based on either an RF conducted or a radiated measurement. Attenuation below the general limits specified in Section 15.209(a) is not required. In addition, radiated emissions which fall in the restricted bands, as defined in Section 15.205(a), must also comply with the radiated emission limits specified in Section 15.209(a) (see Section 5.205(c)).</p>	
54 dB μ V/m AVG	

Result:

Scenario	Band Edge Compliance Radiated [dB μ V/m]	
	DSSS	OFDM
Modulation		
Lower Band Edge – Channel 1	< 54 dB μ V/m (see plot 1)	< 54 dB μ V/m (see plot 3)
Upper Band Edge – Channel 11	< 54 dB μ V/m (see plot 2)	< 54 dB μ V/m (see plot 4)
Measurement uncertainty	\pm 3 dB	

Result: The result of the measurement is passed.

Plots: DSSS / b – mode

Plot 1: TX mode, lower band edge, vertical polarization

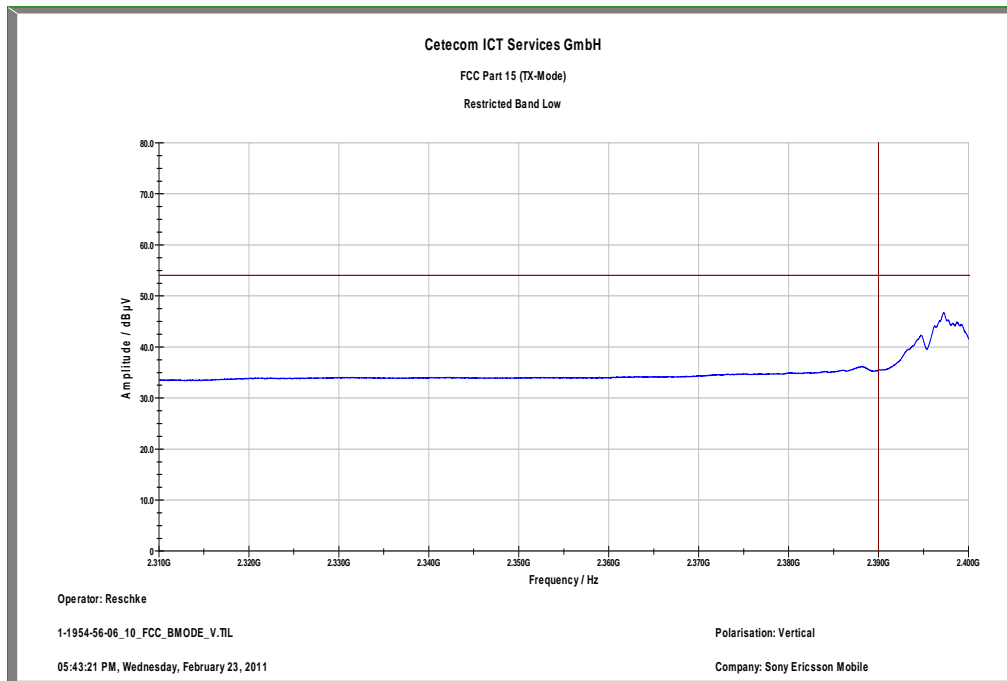

Plot 2: TX mode, upper band edge, vertical polarization

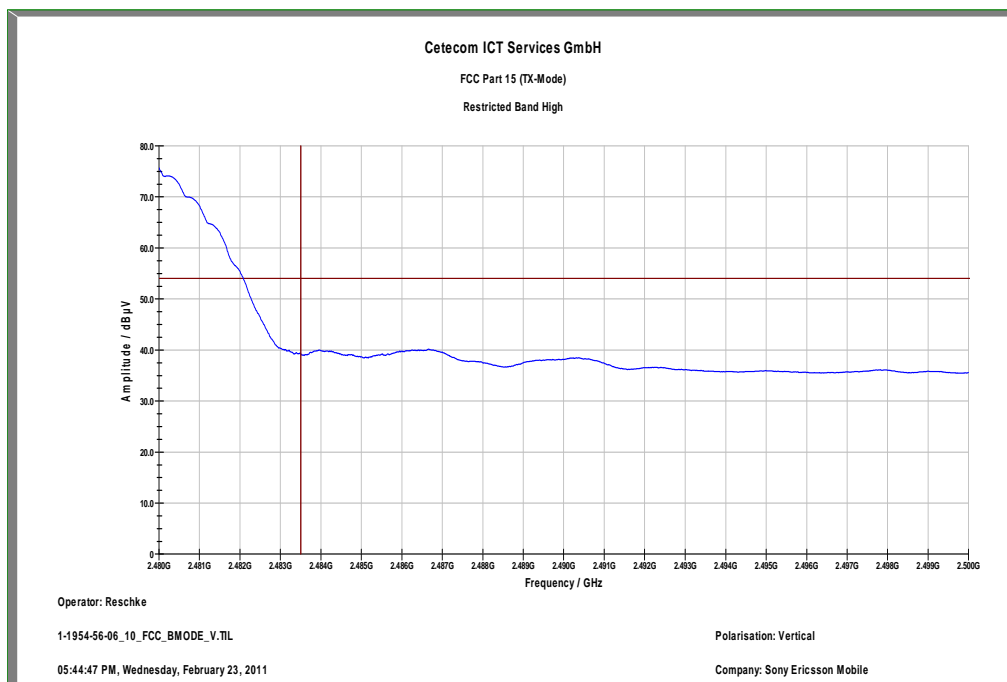

Plot 3: TX mode, lower band edge, horizontal polarization

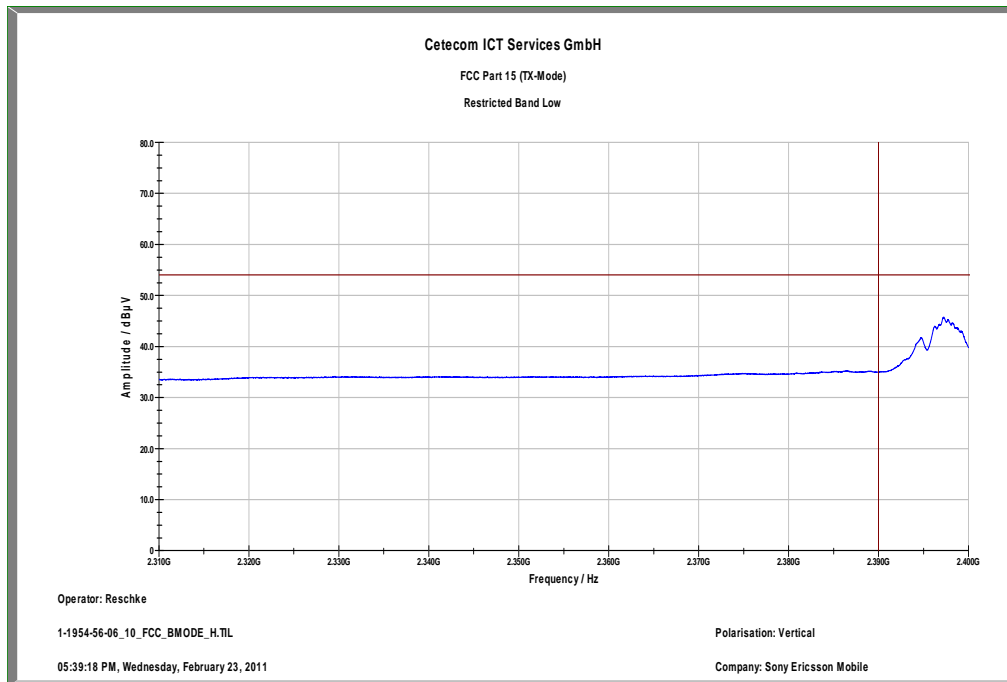

Plot 4: TX mode, upper band edge, horizontal polarization

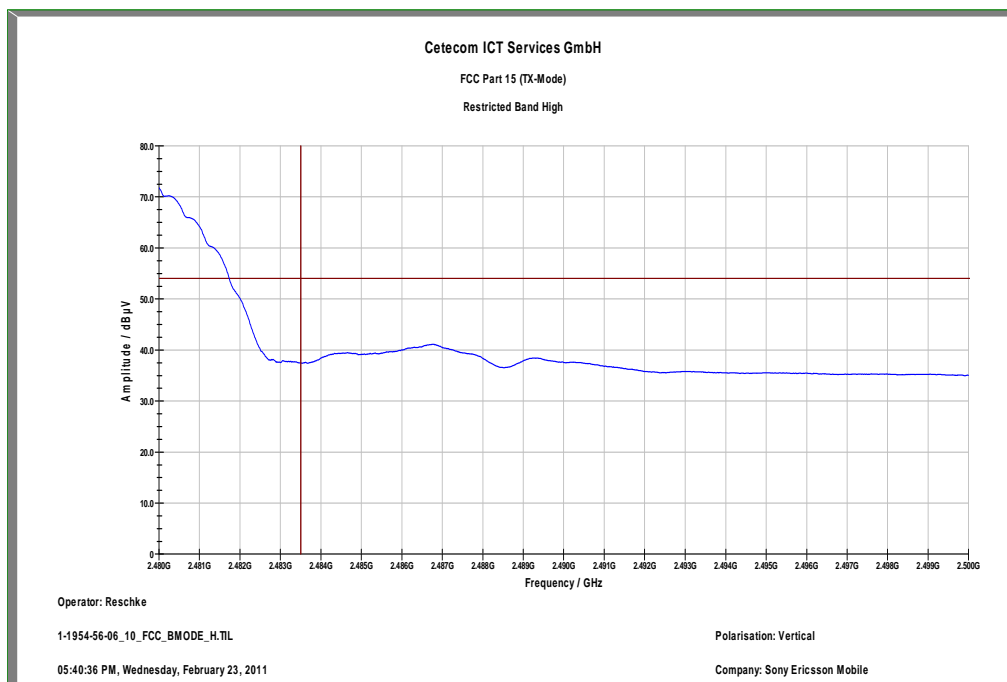

Plots: OFDM / g – mode

Plot 1: TX mode, lower band edge, vertical polarization

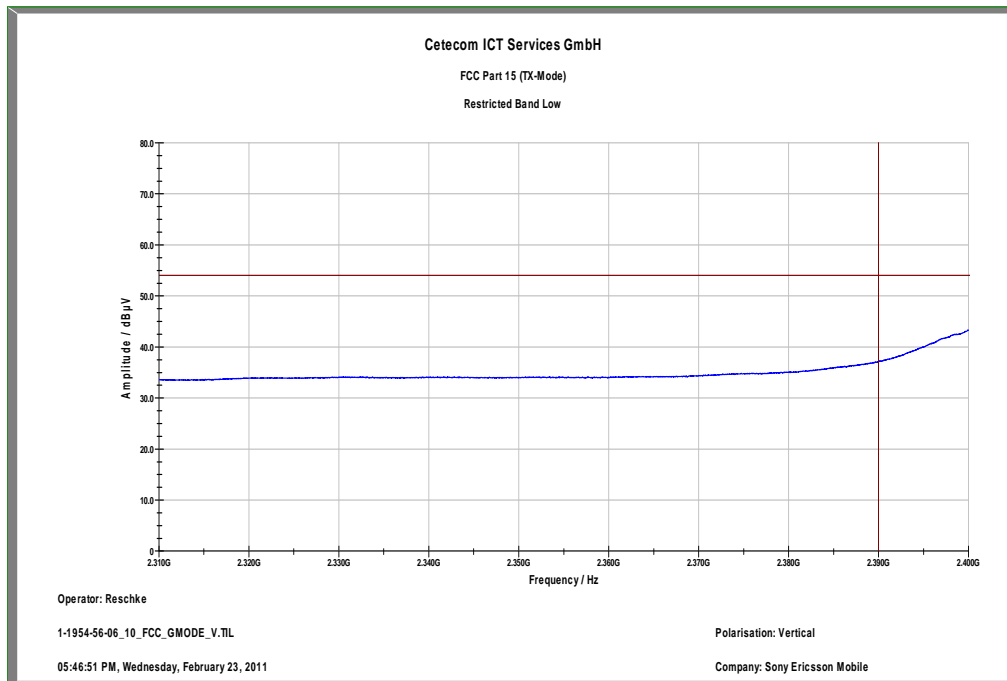

Plot 2: TX mode, upper band edge, vertical polarization

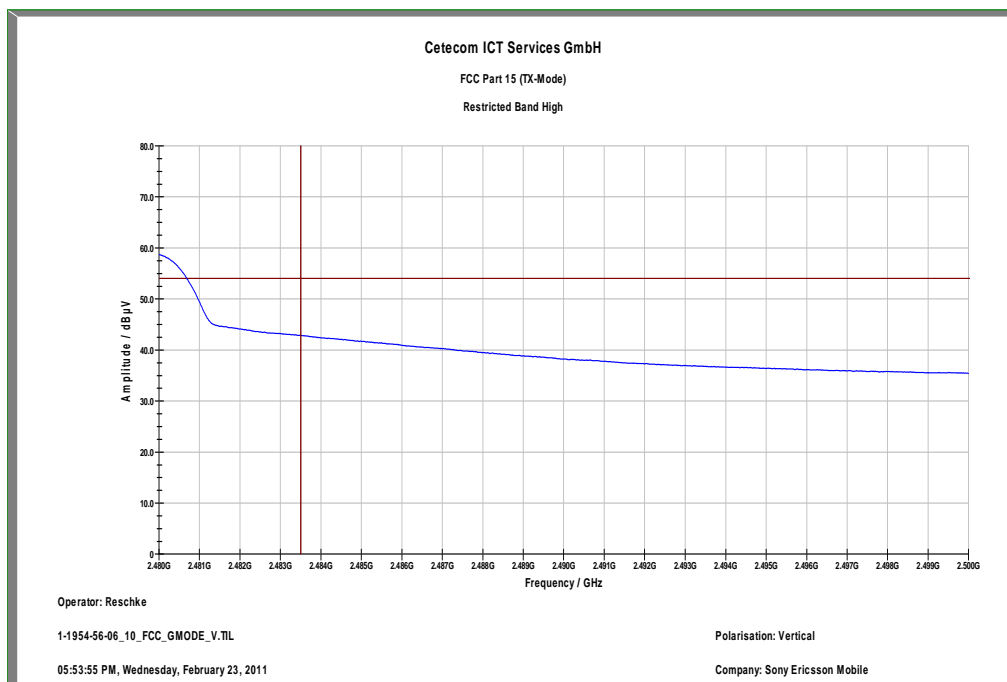

Plot 3: TX mode, lower band edge, horizontal polarization

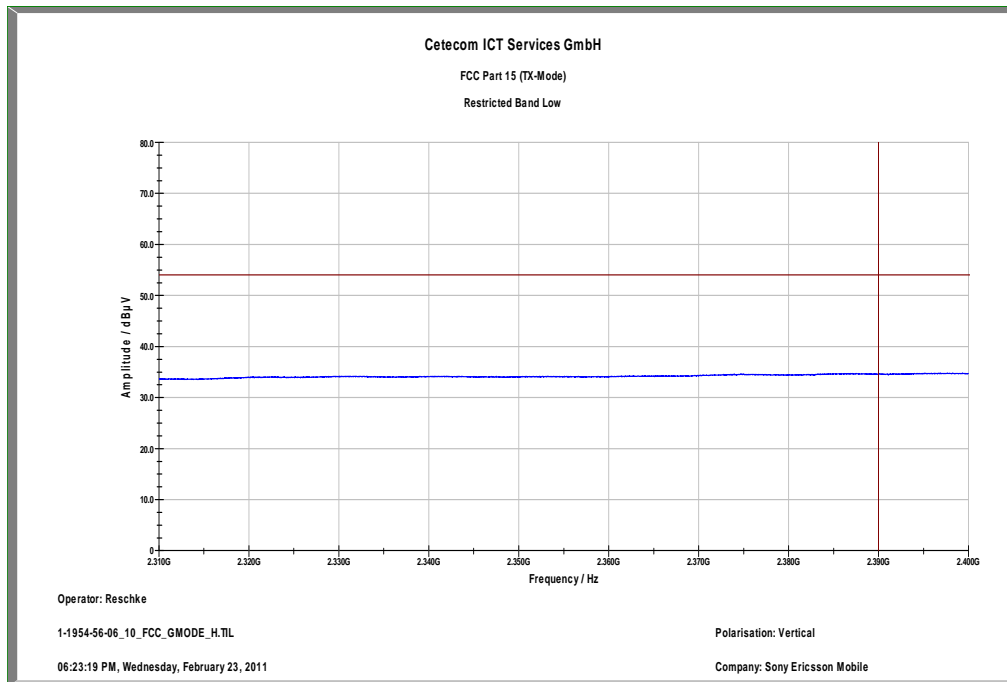

Plot 4: TX mode, upper band edge, horizontal polarization

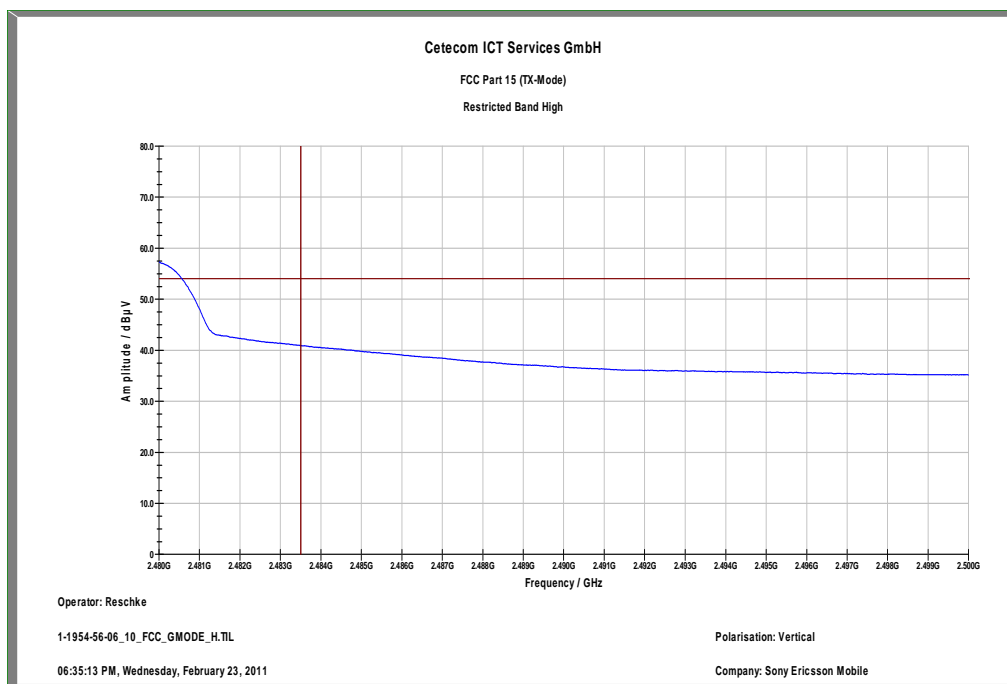

Plots: OFDM / n – mode

Plot 1: TX mode, lower band edge, vertical polarization

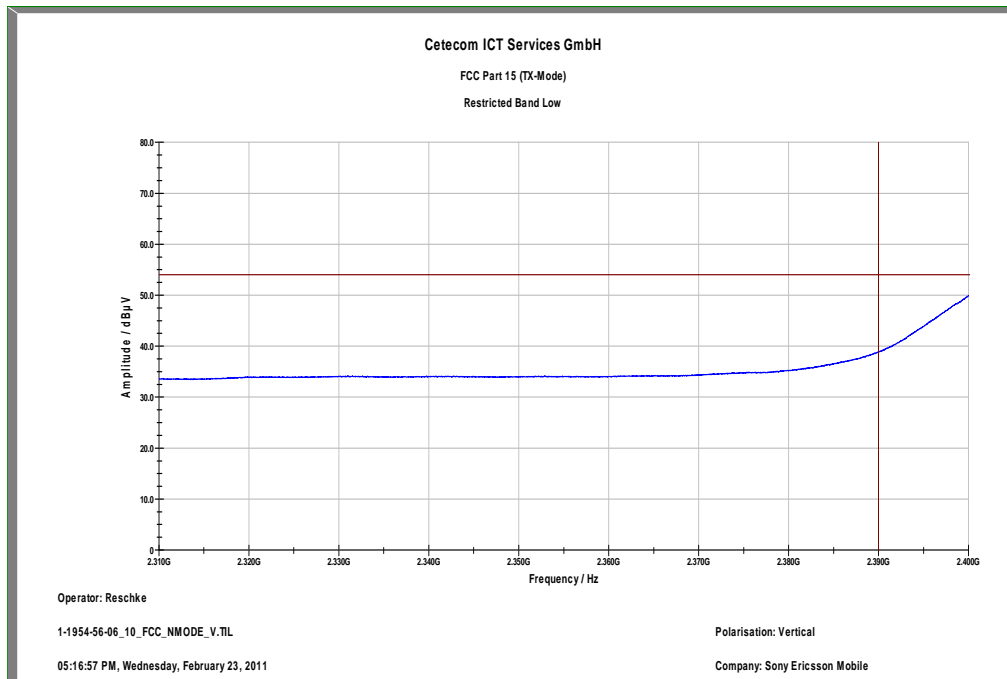

Plot 2: TX mode, upper band edge, vertical polarization

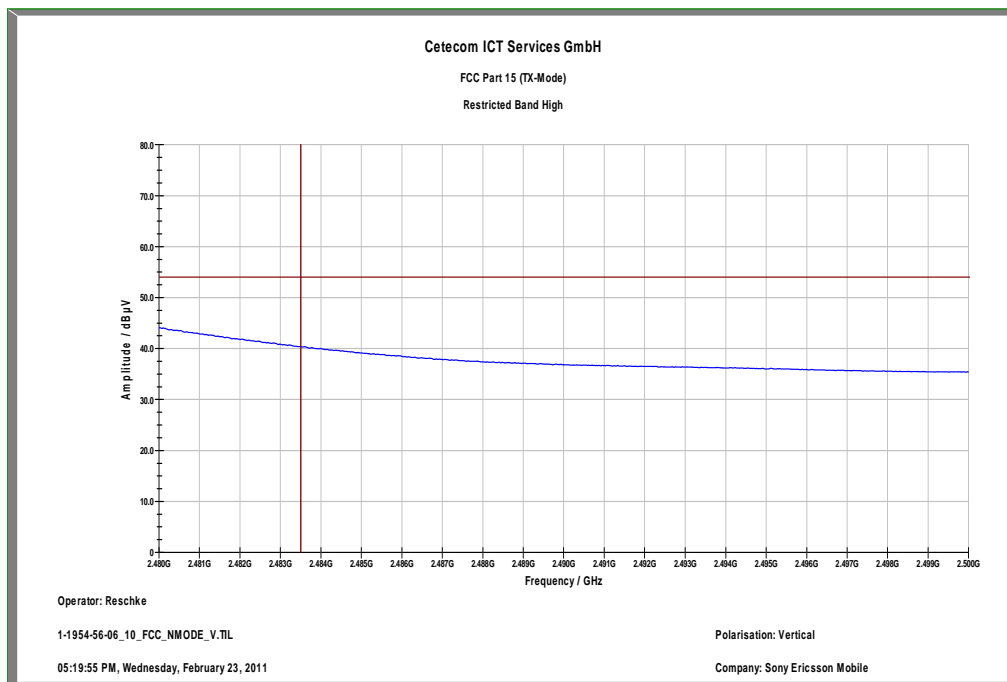

Plot 3: TX mode, lower band edge, horizontal polarization

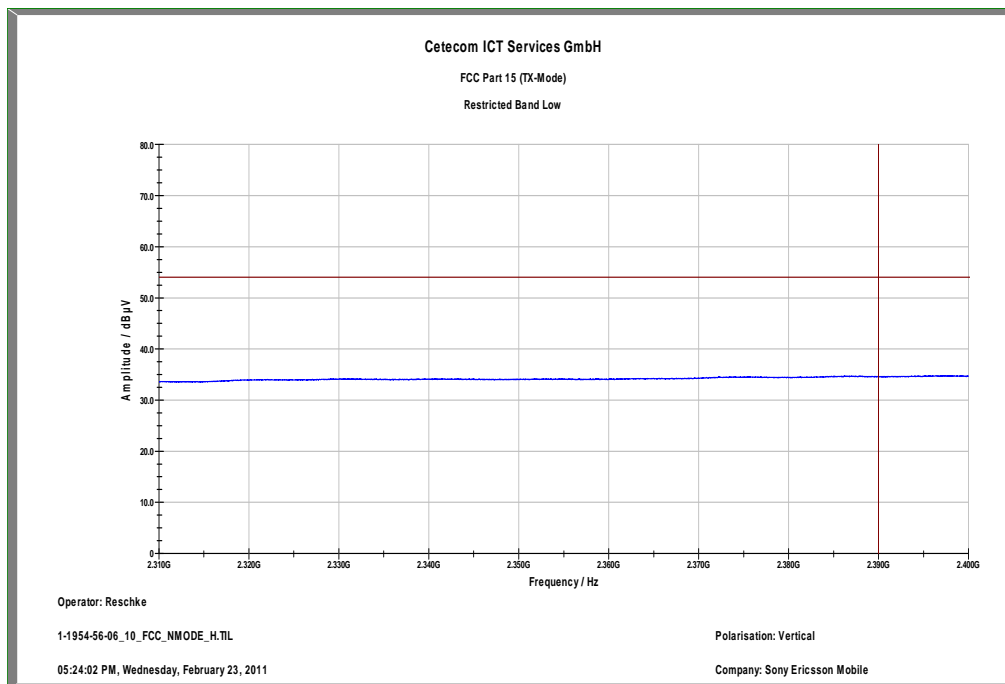

Plot 4: TX mode, upper band edge, horizontal polarization

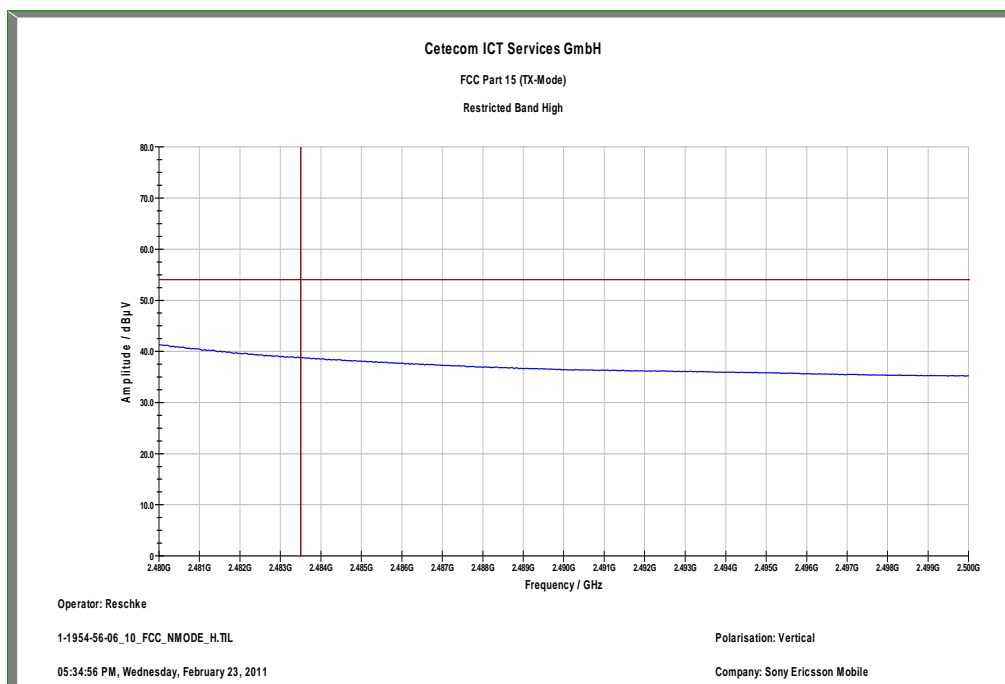

9.9 TX spurious emissions conducted

Description:

Measurement of the conducted spurious emissions in transmit mode. The measurement is performed at channel 1, 6 and 11. The measurement is repeated for all modulations.

Measurement:

Measurement parameter	
Detector:	Peak
Sweep time:	Auto
Video bandwidth:	F < 1 GHz: 100 kHz F > 1 GHz: 100 kHz
Resolution bandwidth:	F < 1 GHz: 100 kHz F > 1 GHz: 100 kHz
Span:	9 kHz to 25 GHz
Trace-Mode:	Max Hold

Limits:

FCC	IC
CFR Part 15.247(d)	RSS 210, Issue 8, A 8.5
TX Spurious Emissions Conducted	
<p>In any 100 kHz bandwidth outside the frequency band in which the spread spectrum or digitally modulated intentional radiator is operating, the radio frequency power that is produced by the intentional radiator shall be at least 20 dB below that in the 100 kHz bandwidth within the band that contains the highest level of the desired power, based on either an RF conducted or a radiated measurement. Attenuation below the general limits specified in Section 15.209(a) is not required</p>	

Results: DSSS / b – mode

TX Spurious Emissions Conducted					
DSSS - mode					
f [MHz]		amplitude of emission [dBm]	limit max. allowed emission power	actual attenuation below frequency of operation [dB]	results
2412		9.8	30 dBm		Operating frequency
		<i>No critical peaks found</i>			complies
			-20 dBc		
2437		9.1	30 dBm		Operating frequency
		<i>No critical peaks found</i>			complies
			-20 dBc		
2462		9.2	30 dBm		Operating frequency
		<i>No critical peaks found</i>			complies
			-20 dBc		
Measurement uncertainty			± 3 dB		

Result: The result of the measurement is passed.

Results: OFDM / g – mode

TX Spurious Emissions Conducted					
OFDM - mode					
f [MHz]		amplitude of emission [dBm]	limit max. allowed emission power	actual attenuation below frequency of operation [dB]	results
2412		5.8	30 dBm		Operating frequency
		<i>No critical peaks found</i>			complies
			-20 dBc		
2437		5.3	30 dBm		Operating frequency
		<i>No critical peaks found</i>			complies
			-20 dBc		
2462		4.7	30 dBm		Operating frequency
		<i>No critical peaks found</i>			complies
			-20 dBc		
Measurement uncertainty			± 3 dB		

Result: The result of the measurement is passed.

Results: OFDM / n – mode

TX Spurious Emissions Conducted					
OFDM - mode					
f [MHz]		amplitude of emission [dBm]	limit max. allowed emission power	actual attenuation below frequency of operation [dB]	results
2412		5.7	30 dBm		Operating frequency
<i>No critical peaks found</i>			-20 dBc		complies
2437		5.3	30 dBm		Operating frequency
<i>No critical peaks found</i>			-20 dBc		complies
2462		5.1	30 dBm		Operating frequency
<i>No critical peaks found</i>			-20 dBc		complies
Measurement uncertainty		± 3 dB			

Result: The result of the measurement is passed.

Plots: DSSS / b – mode

Plot 1: TX mode, lowest channel, 0 MHz to 26 GHz

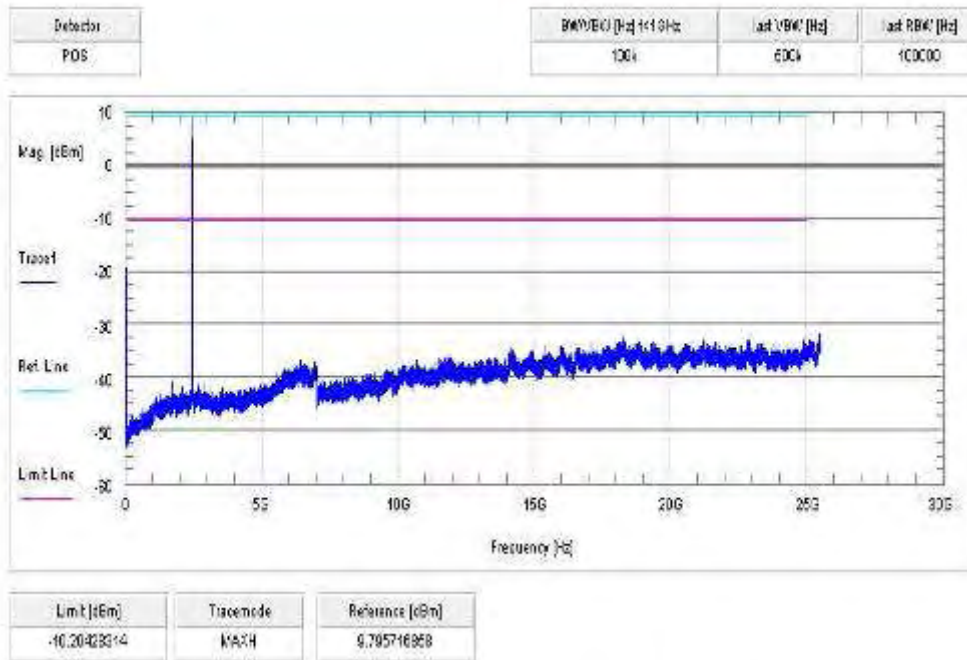

Plot 2: TX mode, middle channel, 0 MHz to 26 GHz

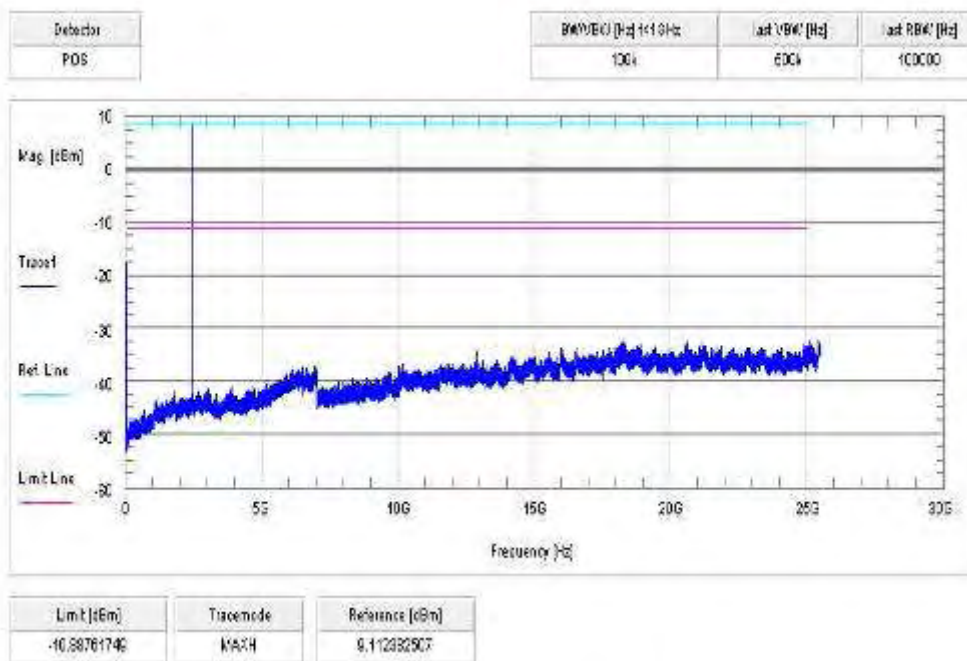

Plot 3: TX mode, highest channel, 0 MHz to 26 GHz

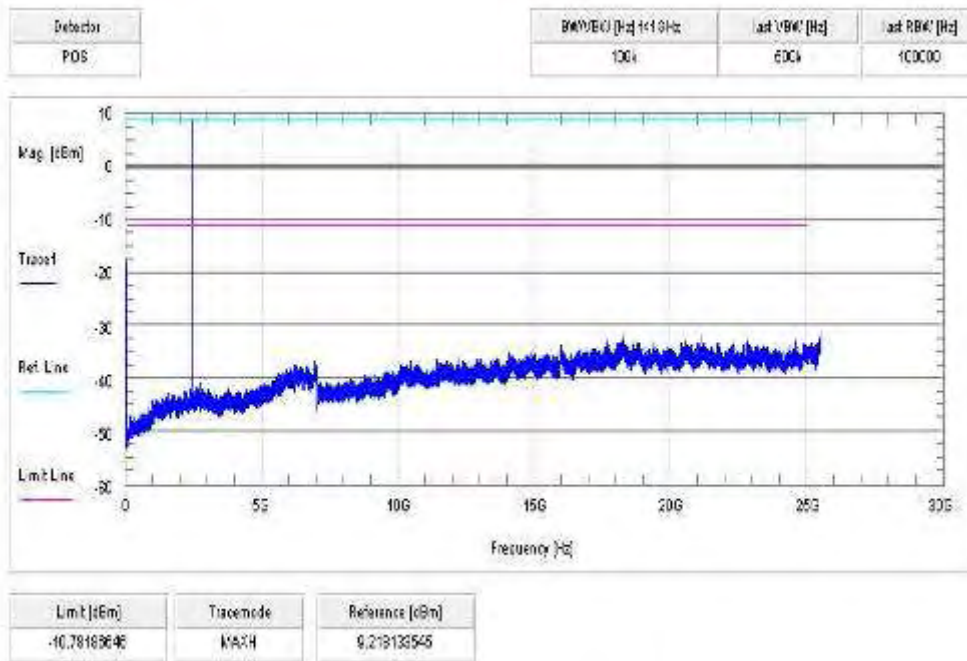

Plots: OFDM / g – mode

Plot 1: TX mode, lowest channel, 0 MHz to 26 GHz

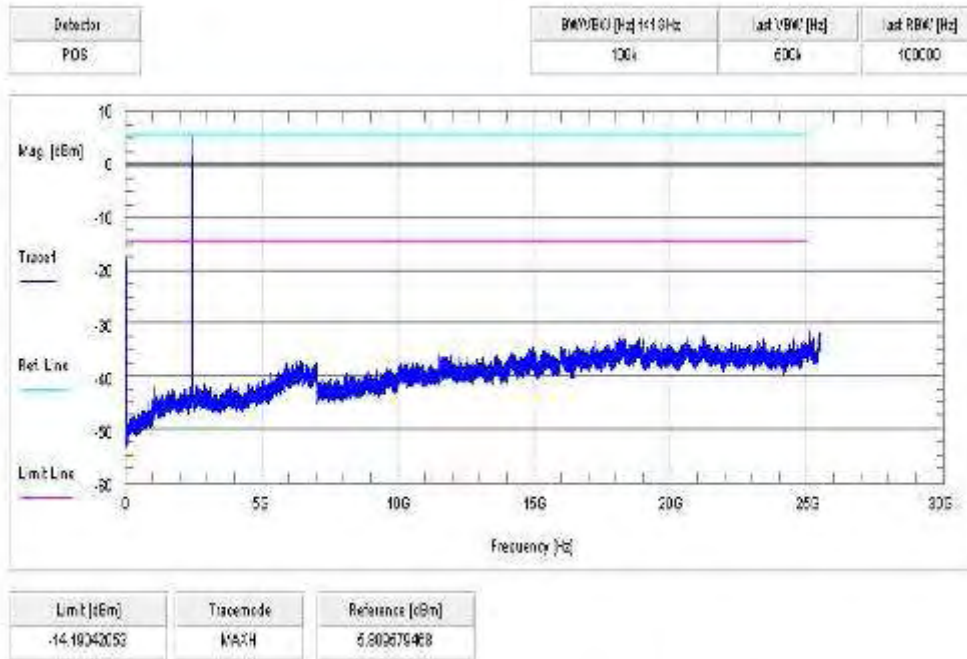

Plot 2: TX mode, middle channel, 0 MHz to 26 GHz

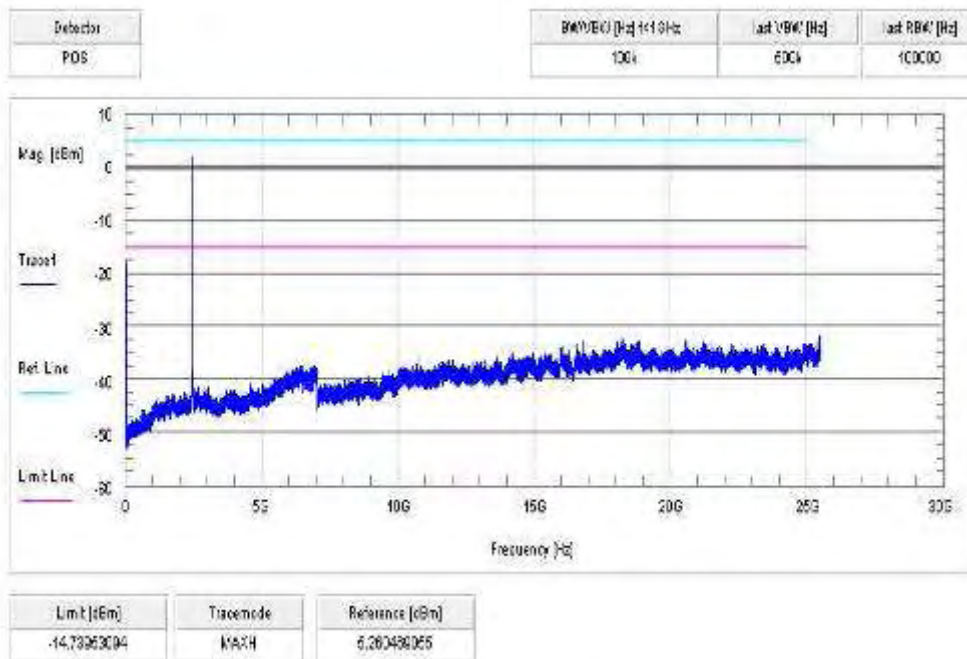

Plot 3: TX mode, highest channel, 0 MHz to 26 GHz

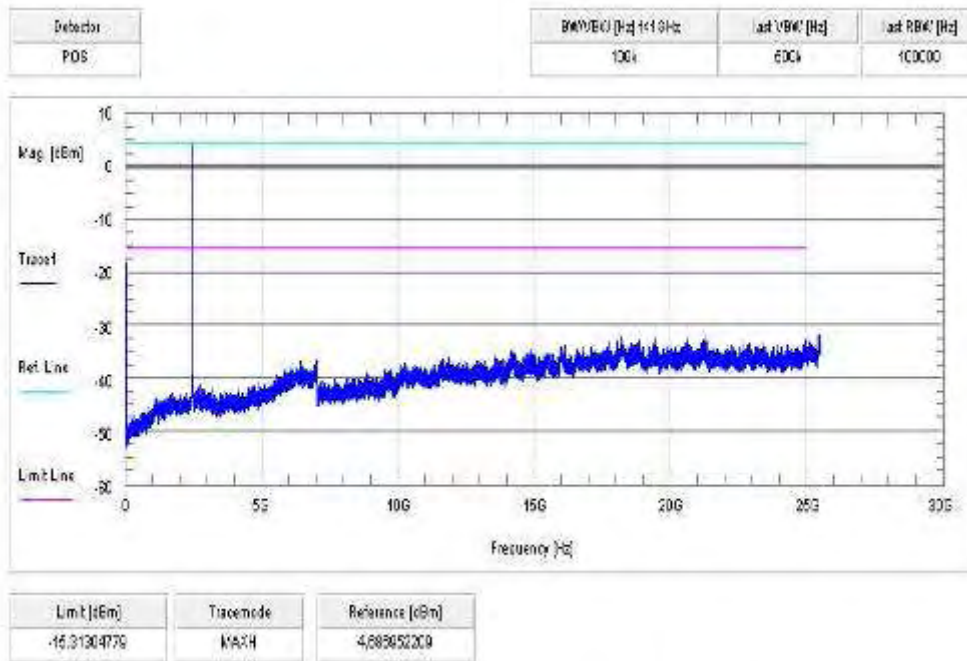

Plots: OFDM / n – mode

Plot 1: TX mode, lowest channel, 0 MHz to 26 GHz

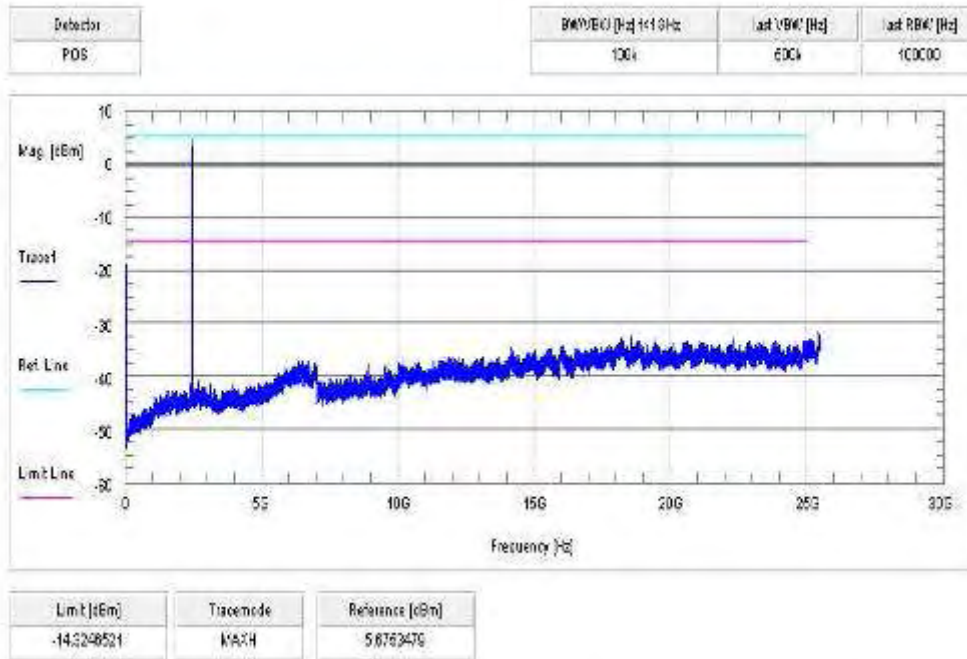

Plot 2: TX mode, middle channel, 0 MHz to 26 GHz

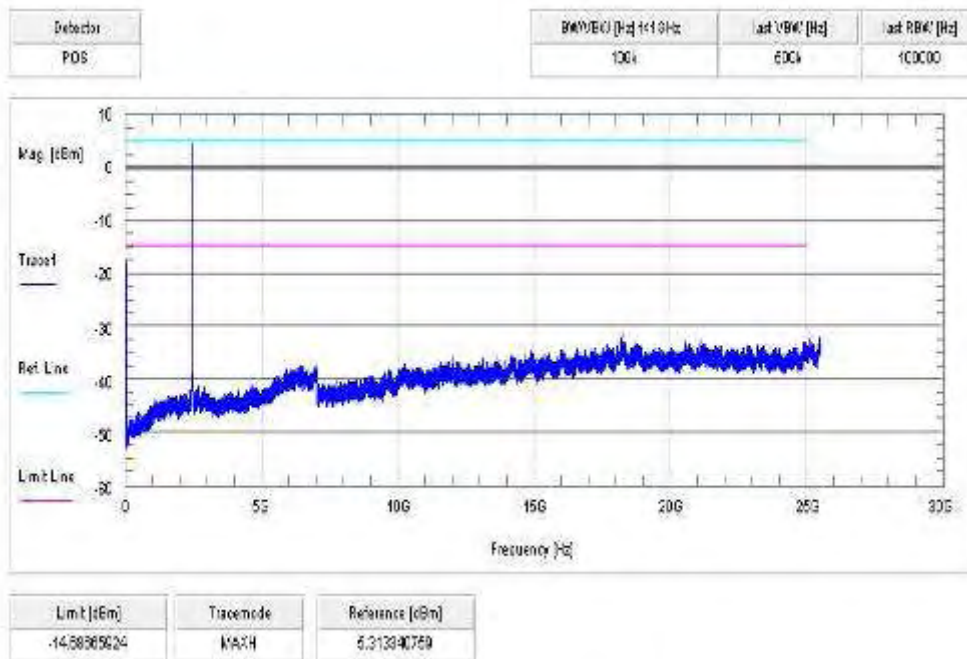

Plot 3: TX mode, highest channel, 0 MHz to 26 GHz

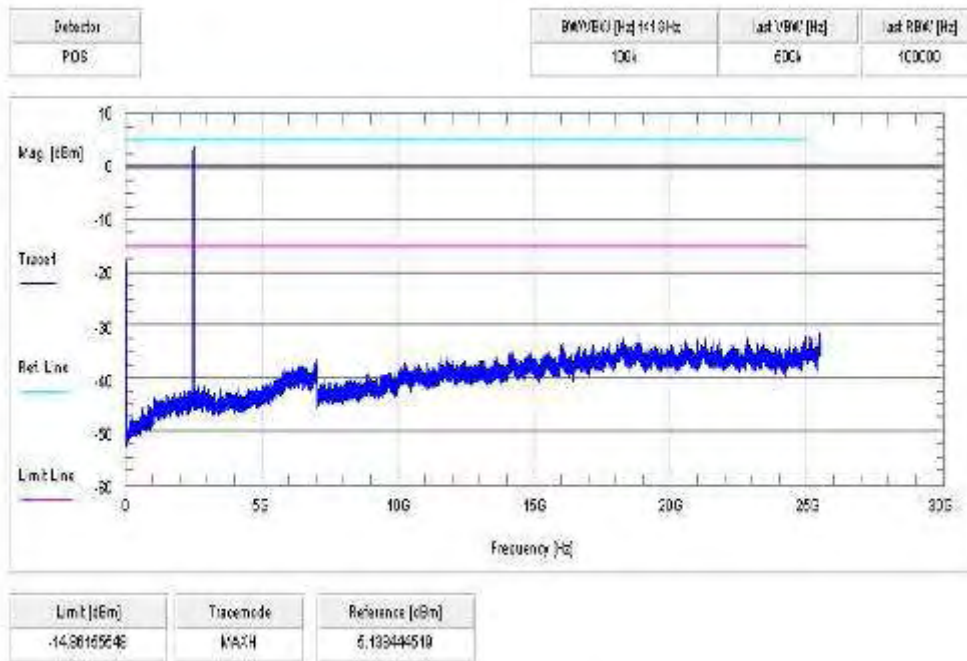

9.10 TX spurious emissions radiated

Description:

Measurement of the radiated spurious emissions in transmit mode. The measurement is performed at channel 1, 6 and 11. The measurement is repeated for all modulations.

Measurement:

Measurement parameter	
Detector:	Peak / Quasi Peak
Sweep time:	Auto
Video bandwidth:	Sweep: 100 kHz Remeasurement: 10 Hz
Resolution bandwidth:	F < 1 GHz: 100 kHz F > 1 GHz: 1 MHz
Span:	30 MHz to 25 GHz
Trace-Mode:	Max Hold
Measured Modulation	<input checked="" type="checkbox"/> DSSS <input checked="" type="checkbox"/> OFDM g & n

The modulation with the highest output power was used to perform the transmitter spurious emissions. If spurious were detected a re-measurement was performed on the detected frequency with each modulation.

Limits:

FCC		IC	
CFR Part 15.247(d)		RSS 210, Issue 8, A 8.5	
TX Spurious Emissions Radiated			
<p>In any 100 kHz bandwidth outside the frequency band in which the spread spectrum or digitally modulated intentional radiator is operating, the radio frequency power that is produced by the intentional radiator shall be at least 20 dB below that in the 100 kHz bandwidth within the band that contains the highest level of the desired power, based on either an RF conducted or a radiated measurement. Attenuation below the general limits specified in Section 15.209(a) is not required. In addition, radiated emissions which fall in the restricted bands, as defined in §15.205(a), must also comply with the radiated emission limits specified in §15.209(a) (see §15.205(c)).</p>			
§15.209			
Frequency (MHz)	Field Strength (dBµV/m)	Measurement distance	
30 - 88	30.0	10	
88 – 216	33.5	10	
216 – 960	36.0	10	
Above 960	54.0	3	

Results: DSSS / b – mode

TX Spurious Emissions Radiated [dB μ V/m]								
DSSS – mode								
2412 MHz			2437 MHz			2462 MHz		
F [MHz]	Detector	Level [dB μ V/m]	F [MHz]	Detector	Level [dB μ V/m]	F [MHz]	Detector	Level [dB μ V/m]
For emissions below 1 GHz, please take a look at the table below the 1 GHz plot.			For emissions below 1 GHz, please take a look at the table below the 1 GHz plot.			For emissions below 1 GHz, please take a look at the table below the 1 GHz plot.		
No critical peaks detected between 1 GHz and 12.75 GHz.			No critical peaks detected between 1 GHz and 12.75 GHz.			No critical peaks detected between 1 GHz and 12.75 GHz.		
For emissions above 12.75 GHz, please take a look at the plots.			For emissions above 12.75 GHz, please take a look at the plots.			For emissions above 12.75 GHz, please take a look at the plots.		
Measurement uncertainty						± 3 dB		

Result: The result of the measurement is passed.

Results: OFDM / g – mode

TX Spurious Emissions Radiated [dB μ V/m]								
OFDM – mode								
2412 MHz			2437 MHz			2462 MHz		
F [MHz]	Detector	Level [dB μ V/m]	F [MHz]	Detector	Level [dB μ V/m]	F [MHz]	Detector	Level [dB μ V/m]
For emissions below 1 GHz, please take a look at the table below the 1 GHz plot.			For emissions below 1 GHz, please take a look at the table below the 1 GHz plot.			For emissions below 1 GHz, please take a look at the table below the 1 GHz plot.		
No critical peaks detected between 1 GHz and 12.75 GHz.			No critical peaks detected between 1 GHz and 12.75 GHz.			No critical peaks detected between 1 GHz and 12.75 GHz.		
For emissions above 12.75 GHz, please take a look at the plots.			For emissions above 12.75 GHz, please take a look at the plots.			For emissions above 12.75 GHz, please take a look at the plots.		
Measurement uncertainty						± 3 dB		

Result: The result of the measurement is passed.

Results: OFDM / n – mode

TX Spurious Emissions Radiated [dB μ V/m]								
OFDM – mode								
2412 MHz			2437 MHz			2462 MHz		
F [MHz]	Detector	Level [dB μ V/m]	F [MHz]	Detector	Level [dB μ V/m]	F [MHz]	Detector	Level [dB μ V/m]
For emissions below 1 GHz, please take a look at the table below the 1 GHz plot.			For emissions below 1 GHz, please take a look at the table below the 1 GHz plot.			For emissions below 1 GHz, please take a look at the table below the 1 GHz plot.		
No critical peaks detected between 1 GHz and 12.75 GHz.			No critical peaks detected between 1 GHz and 12.75 GHz.			No critical peaks detected between 1 GHz and 12.75 GHz.		
For emissions above 12.75 GHz, please take a look at the plots.			For emissions above 12.75 GHz, please take a look at the plots.			For emissions above 12.75 GHz, please take a look at the plots.		
Measurement uncertainty						± 3 dB		

Result: The result of the measurement is passed.

Plots: DSSS / b – mode

Plot 1: Lowest channel, 30 MHz to 1 GHz, vertical & horizontal polarization

CETECOM ICT Services GmbH

Common Information

EUT: AAD-3880100-BV
 Serial Number: CB5A1CGN7M
 Test Description: FCC part 15 class B @ 10 m
 Operating Conditions: WLAN b-mode TX low channel + charging
 Operator Name: Hennemann
 Comment: AC: 115 V / 60 Hz

Scan Setup: STAN_Fin [EMI radiated]

Hardware Setup: Electric Field (NOS)
 Level Unit: dBµV/m

Subrange	Detectors	IF Bandwidth	Meas. Time	Receiver
30 MHz - 1,05 GHz	QuasiPeak	120 kHz	15 s	Receiver

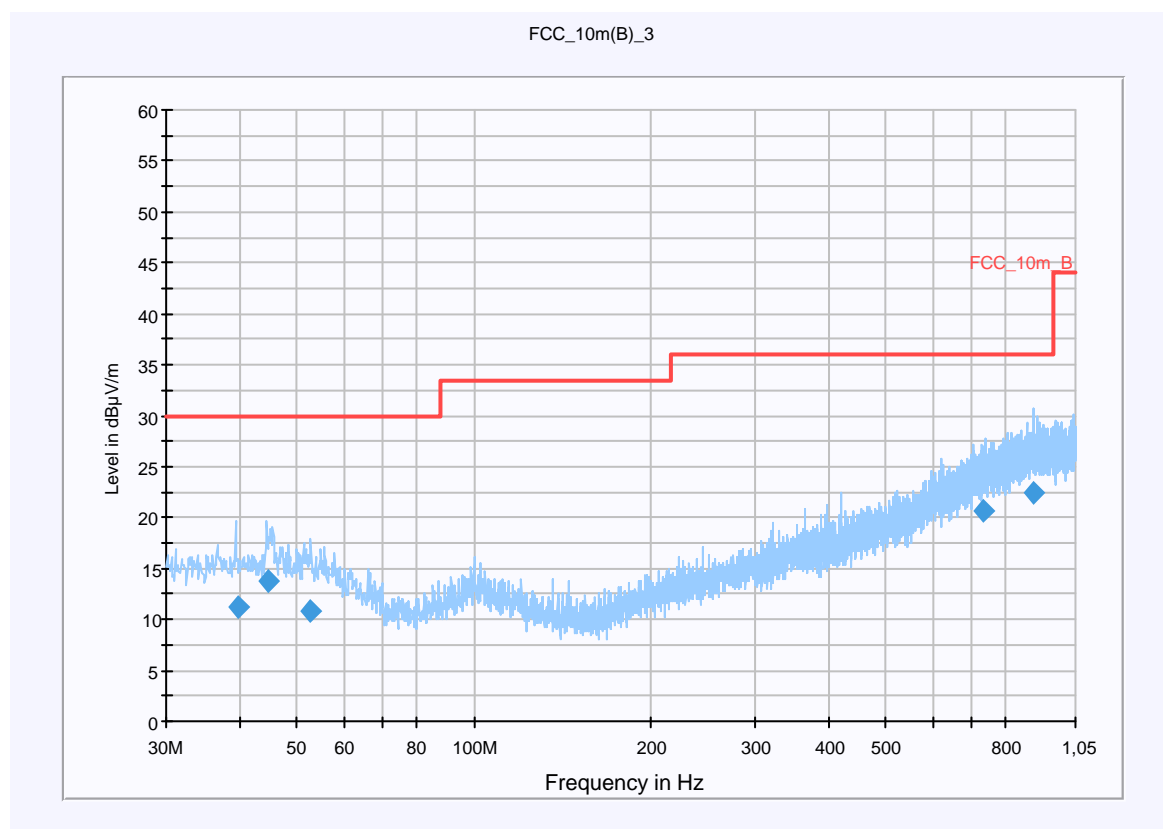

Final Result 1

Frequency (MHz)	QuasiPeak (dBµV/m)	Meas. Time (ms)	Bandwidth (kHz)	Antenna height (cm)	Polarity	Turntable position (deg)	Corr. (dB)	Margin (dB)	Limit (dBµV/m)	Comment
39.622650	11.3	15000.000	120.000	120.0	V	174.0	13.4	18.7	30.0	
44.881050	13.9	15000.000	120.000	98.0	V	23.0	13.3	16.1	30.0	
52.571850	10.8	15000.000	120.000	220.0	V	79.0	13.1	19.2	30.0	
729.971250	20.7	15000.000	120.000	189.0	V	265.0	23.2	15.3	36.0	
892.325100	22.5	15000.000	120.000	170.0	H	57.0	25.1	13.5	36.0	

Hardware Setup: EMI radiated\Electric Field (NOS) - [EMI radiated]

Subrange 1	
Frequency Range:	30 MHz - 2 GHz
Receiver:	Receiver [ESCI 3] @ GPIB0 (ADR 20), SN 100083/003, FW 4.32
Signal Path:	without Notch FW 1.0
Antenna:	VULB 9163 SN 9163-295, FW --- Correction Table (vertical): VULP6113 Correction Table (horizontal): VULP6113 Correction Table: Cable_EN_1GHz (1005)
Antenna Tower:	Tower [EMCO 2090 Antenna Tower] @ GPIB0 (ADR 8), FW REV 3.12
Turntable:	Turntable [EMCO Turntable] @ GPIB0 (ADR 9), FW REV 3.12

EMC 32 Version 8.10.00

Plot 2: Lowest channel, 1 GHz to 12.75 GHz, vertical polarization

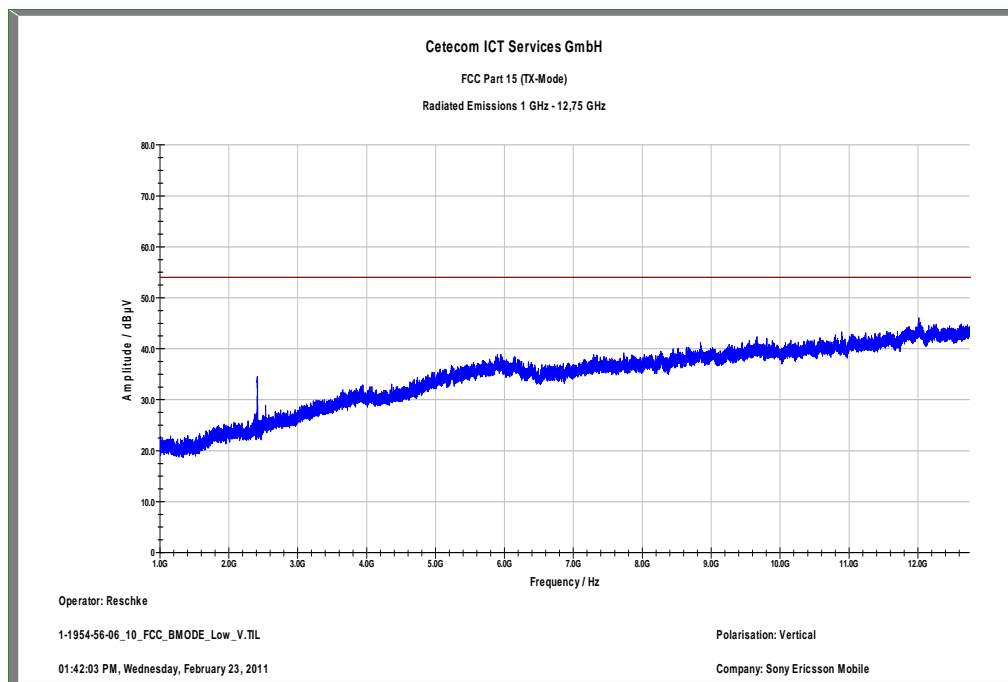

The carrier signal is notched with a 2.4 GHz band rejection filter.

Plot 3: Lowest channel, 1 GHz to 12.75 GHz, horizontal polarization

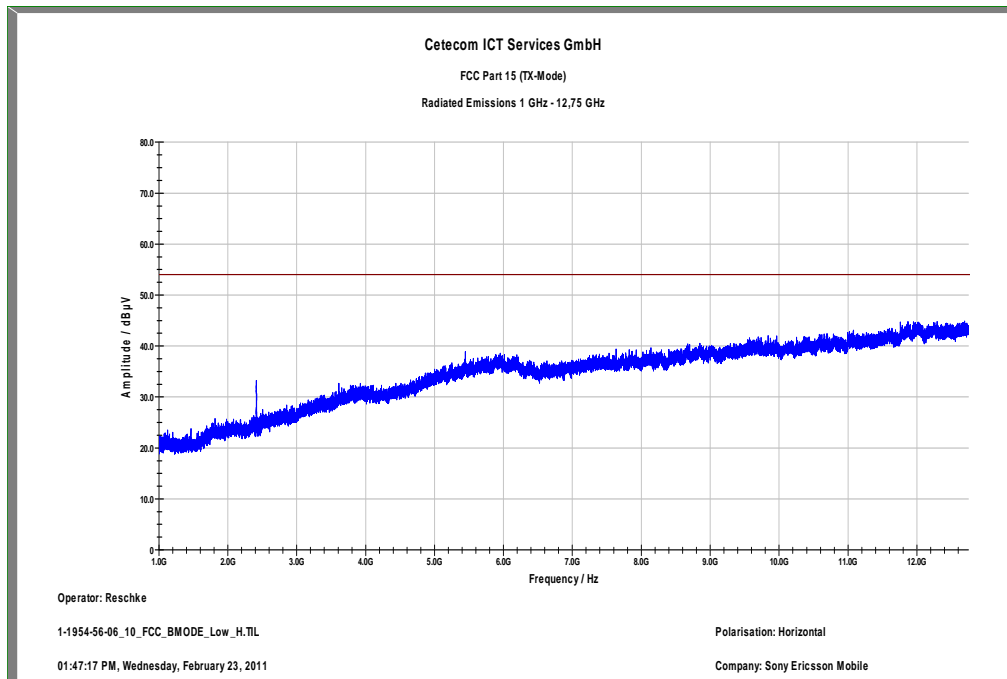

The carrier signal is notched with a 2.4 GHz band rejection filter.

Plot 4: Lowest channel, 12.75 GHz to 18 GHz, vertical & horizontal polarization

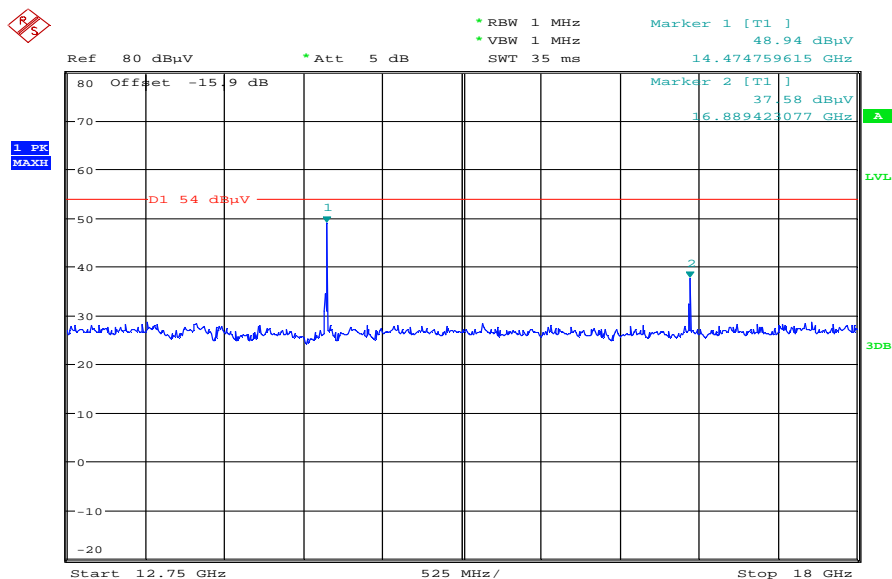

Date: 3.MAR.2011 10:01:07

Plot 5: Lowest channel, 18 GHz to 26 GHz, vertical & horizontal polarization

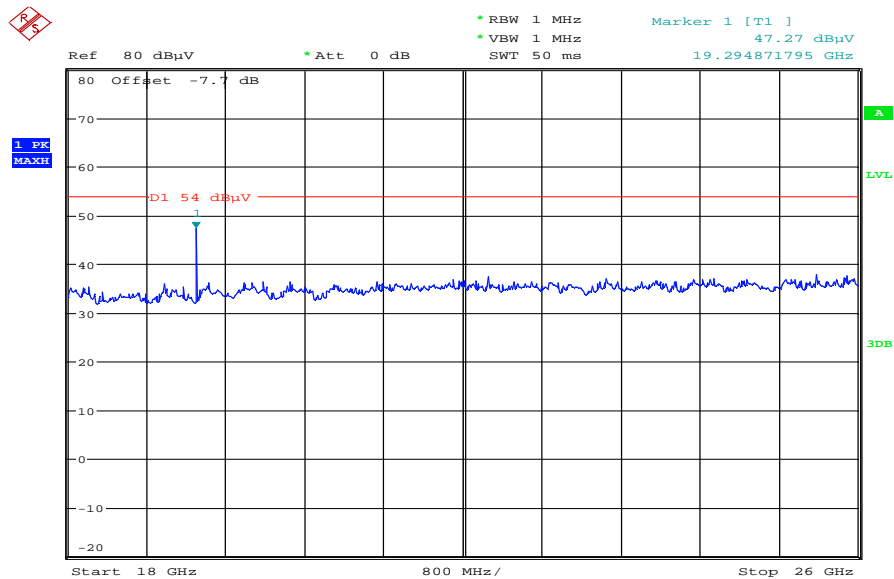

Date: 3.MAR.2011 10:15:45

Plot 6: Middle channel, 30 MHz to 1 GHz, vertical & horizontal polarization

CETECOM ICT Services GmbH

Common Information

EUT: AAD-3880100-BV
 Serial Number: CB5A1CGN7M
 Test Description: FCC part 15 class B @ 10 m
 Operating Conditions: WLAN b-mode TX mid channel + charging
 Operator Name: Hennemann
 Comment: AC: 115 V / 60 Hz

Scan Setup: STAN_Fin [EMI radiated]

Hardware Setup: Electric Field (NOS)
 Level Unit: dB μ V/m
Subrange **Detectors** **IF Bandwidth** **Meas. Time** **Receiver**
 30 MHz - 1,05 GHz QuasiPeak 120 kHz 15 s Receiver

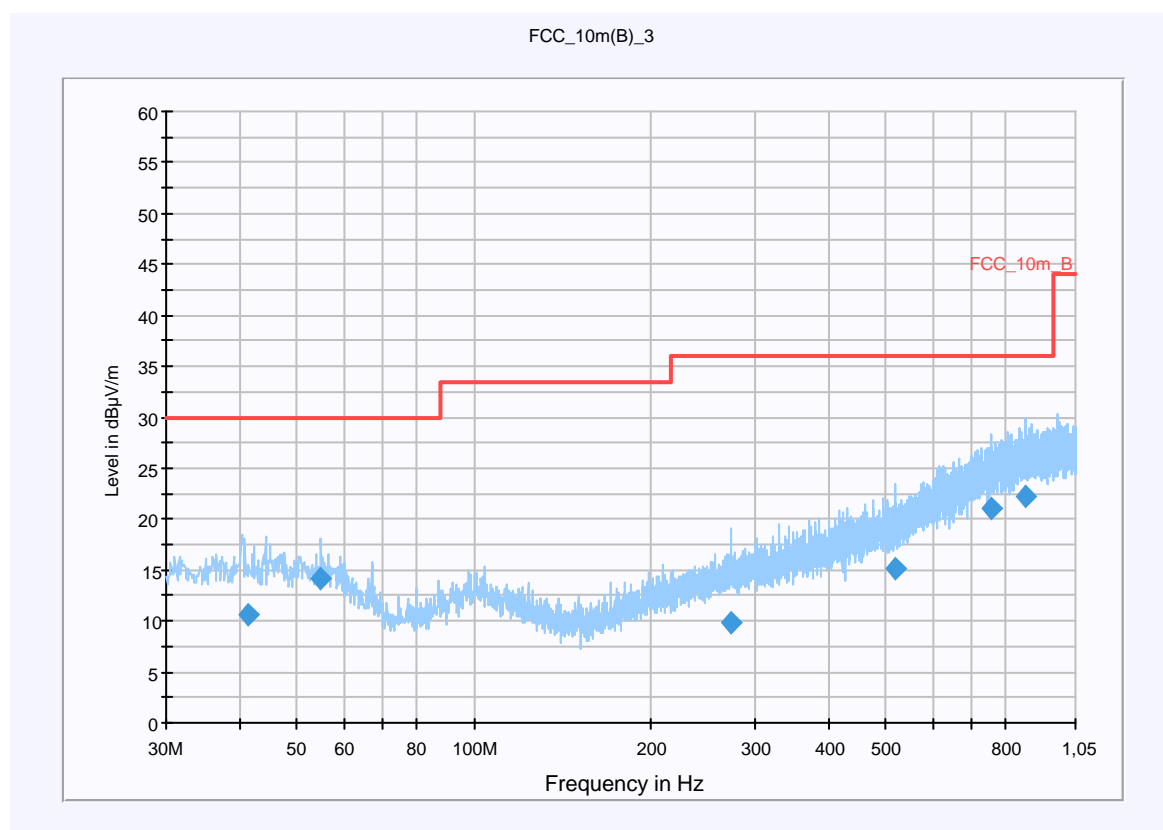

Final Result 1

Frequency (MHz)	QuasiPeak (dB μ V/m)	Meas. Time (ms)	Bandwidth (kHz)	Antenna height (cm)	Polarity	Turntable position (deg)	Corr. (dB)	Margin (dB)	Limit (dB μ V/m)	Comment
41.413650	10.6	15000.000	120.000	185.0	V	38.0	13.4	19.4	30.0	
54.982200	14.2	15000.000	120.000	220.0	V	324.0	12.9	15.8	30.0	
274.075500	9.7	15000.000	120.000	220.0	H	134.0	13.9	26.3	36.0	
520.854750	15.2	15000.000	120.000	220.0	V	65.0	19.0	20.8	36.0	
755.543850	21.0	15000.000	120.000	220.0	V	132.0	23.7	15.0	36.0	
863.251500	22.1	15000.000	120.000	220.0	V	38.0	24.7	13.9	36.0	

Hardware Setup: EMI radiated\Electric Field (NOS) - [EMI radiated]

Subrange 1	
Frequency Range:	30 MHz - 2 GHz
Receiver:	Receiver [ESCI 3] @ GPIB0 (ADR 20), SN 100083/003, FW 4.32
Signal Path:	without Notch FW 1.0
Antenna:	VULB 9163 SN 9163-295, FW --- Correction Table (vertical): VULP6113 Correction Table (horizontal): VULP6113 Correction Table: Cable_EN_1GHz (1005)
Antenna Tower:	Tower [EMCO 2090 Antenna Tower] @ GPIB0 (ADR 8), FW REV 3.12
Turntable:	Turntable [EMCO Turntable] @ GPIB0 (ADR 9), FW REV 3.12

EMC 32 Version 8.10.00

Plot 7: Middle channel, 1 GHz to 12.75 GHz, vertical polarization

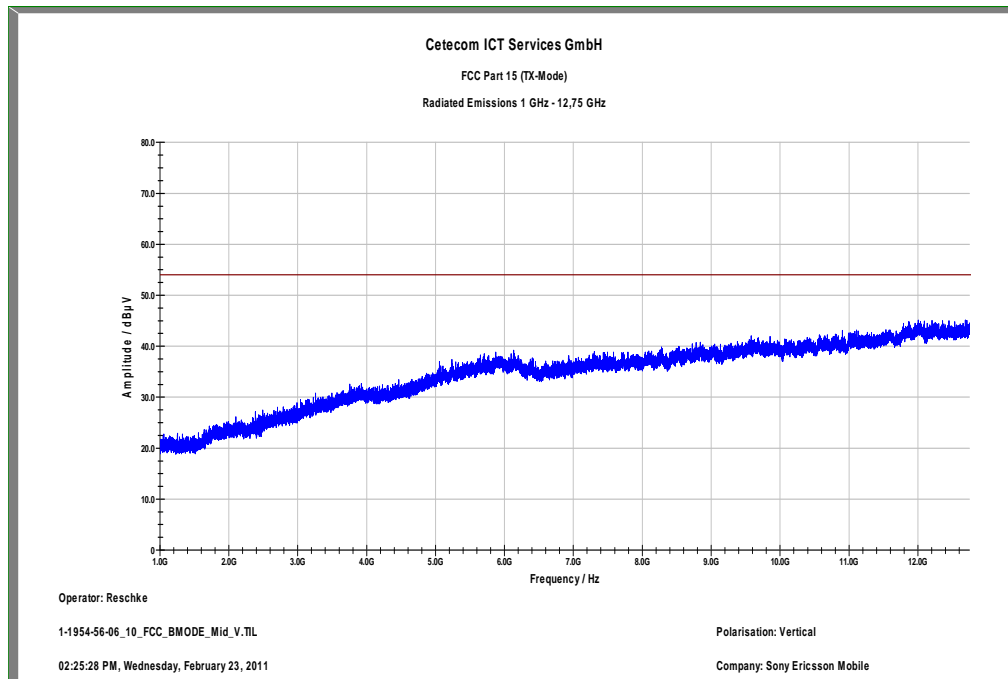

The carrier signal is notched with a 2.4 GHz band rejection filter.

Plot 8: Middle channel, 1 GHz to 12.75 GHz, horizontal polarization

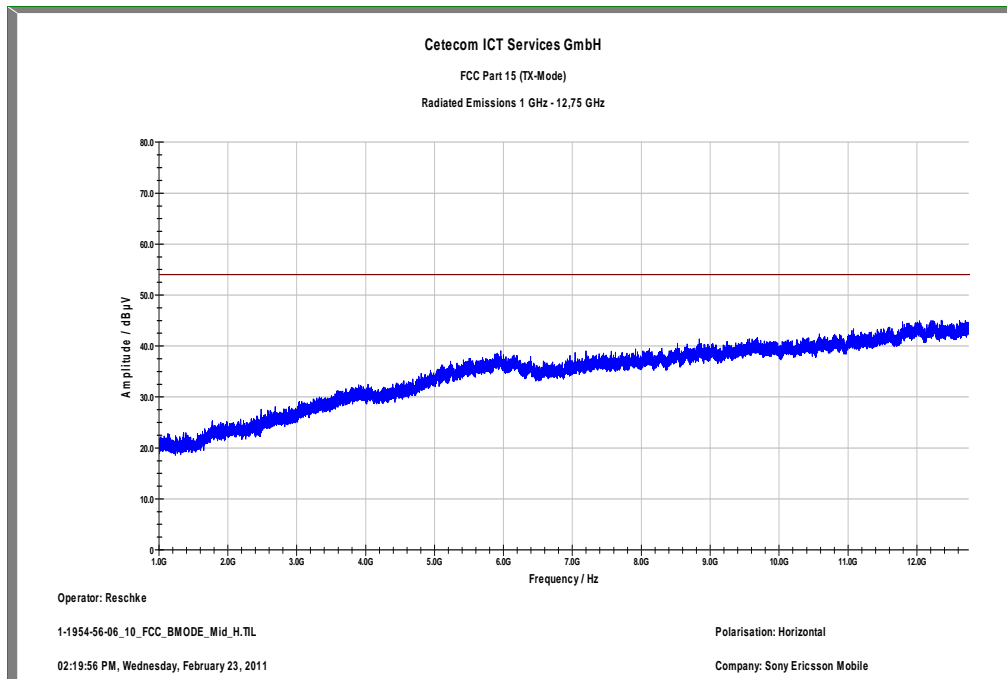

The carrier signal is notched with a 2.4 GHz band rejection filter.

Plot 9: Middle channel, 12.75 GHz to 18 GHz, vertical & horizontal polarization

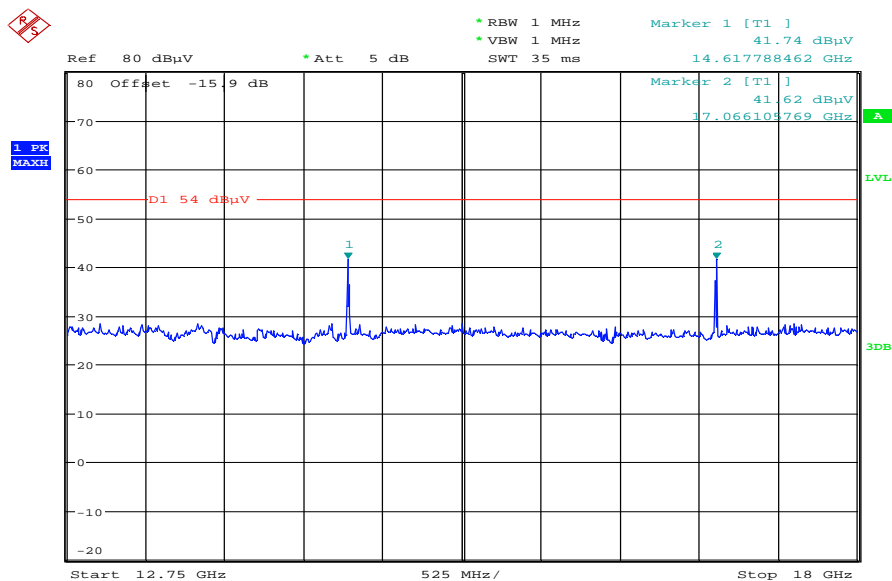

Date: 3.MAR.2011 10:04:33

Plot 10: Middle channel, 18 GHz to 26 GHz, vertical & horizontal polarization

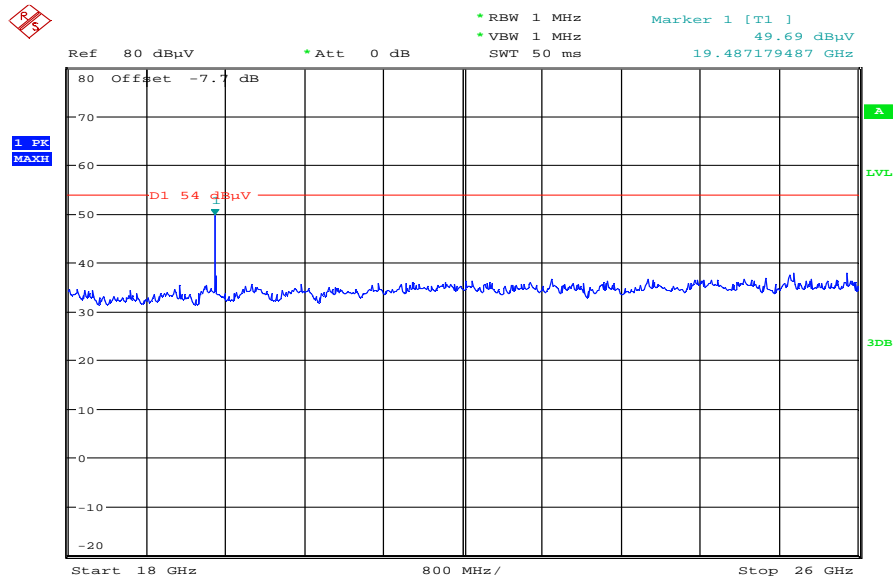

Date: 3.MAR.2011 10:18:11

Plot 11: Highest channel, 30 MHz to 1 GHz, vertical & horizontal polarization

CETECOM ICT Services GmbH

Common Information

EUT: AAD-3880100-BV
 Serial Number: CB5A1CGN7M
 Test Description: FCC part 15 class B @ 10 m
 Operating Conditions: WLAN b-mode TX up channel + charging
 Operator Name: Hennemann
 Comment: AC: 115 V / 60 Hz

Scan Setup: STAN_Fin [EMI radiated]

Hardware Setup: Electric Field (NOS)
 Level Unit: dB μ V/m
Subrange **Detectors** **IF Bandwidth** **Meas. Time** **Receiver**
 30 MHz - 1,05 GHz QuasiPeak 120 kHz 15 s Receiver

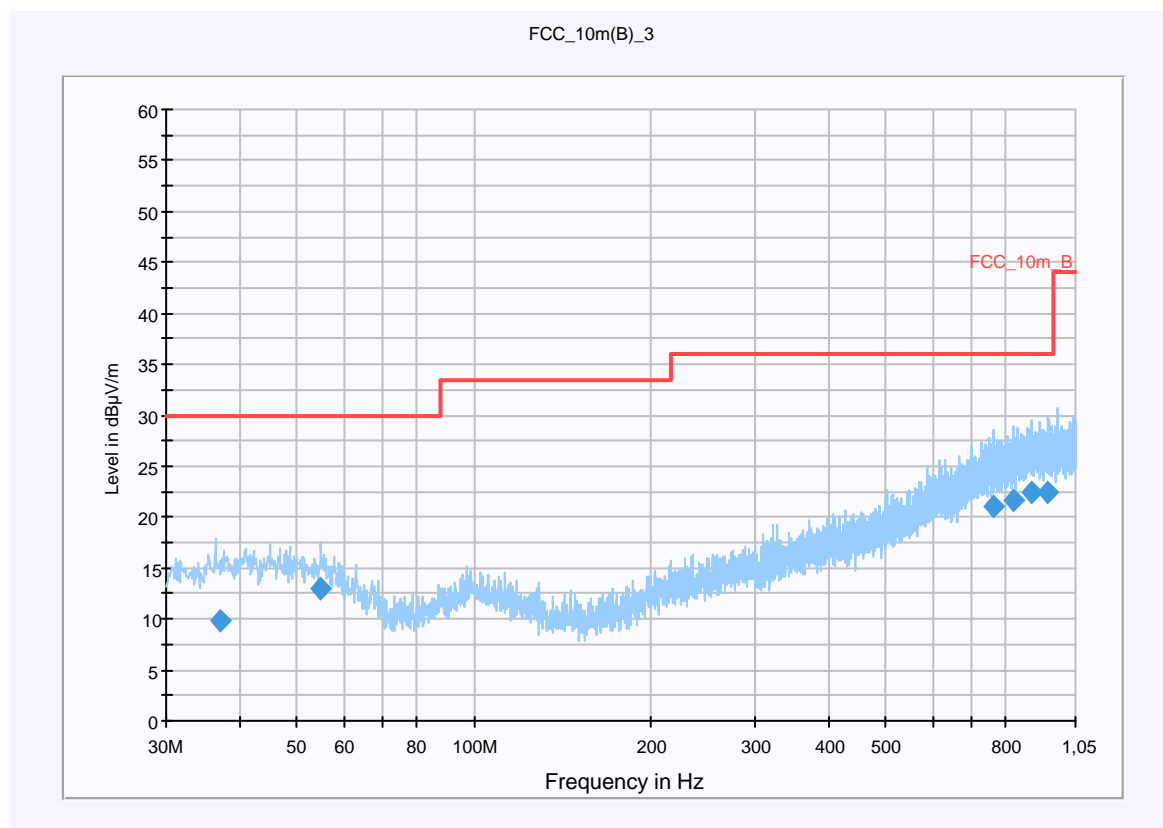

Final Result 1

Frequency (MHz)	QuasiPeak (dB μ V/m)	Meas. Time (ms)	Bandwidth (kHz)	Antenna height (cm)	Polarity	Turntable position (deg)	Corr. (dB)	Margin (dB)	Limit (dB μ V/m)	Comment
36.947550	9.8	15000.000	120.000	120.0	H	219.0	13.2	20.2	30.0	
55.031100	13.0	15000.000	120.000	98.0	V	102.0	12.9	17.0	30.0	
761.676300	21.1	15000.000	120.000	208.0	H	305.0	23.7	14.9	36.0	
825.243600	21.6	15000.000	120.000	105.0	V	124.0	24.2	14.4	36.0	
884.838450	22.4	15000.000	120.000	148.0	V	104.0	25.0	13.6	36.0	
944.449200	22.4	15000.000	120.000	220.0	H	43.0	25.3	13.6	36.0	

Hardware Setup: EMI radiated\Electric Field (NOS) - [EMI radiated]

Subrange 1	
Frequency Range:	30 MHz - 2 GHz
Receiver:	Receiver [ESCI 3] @ GPIB0 (ADR 20), SN 100083/003, FW 4.32
Signal Path:	without Notch FW 1.0
Antenna:	VULB 9163 SN 9163-295, FW --- Correction Table (vertical): VULP6113 Correction Table (horizontal): VULP6113 Correction Table: Cable_EN_1GHz (1005)
Antenna Tower:	Tower [EMCO 2090 Antenna Tower] @ GPIB0 (ADR 8), FW REV 3.12
Turntable:	Turntable [EMCO Turntable] @ GPIB0 (ADR 9), FW REV 3.12

EMC 32 Version 8.10.00

Plot 12: Highest channel, 1 GHz to 12.75 GHz, vertical polarization

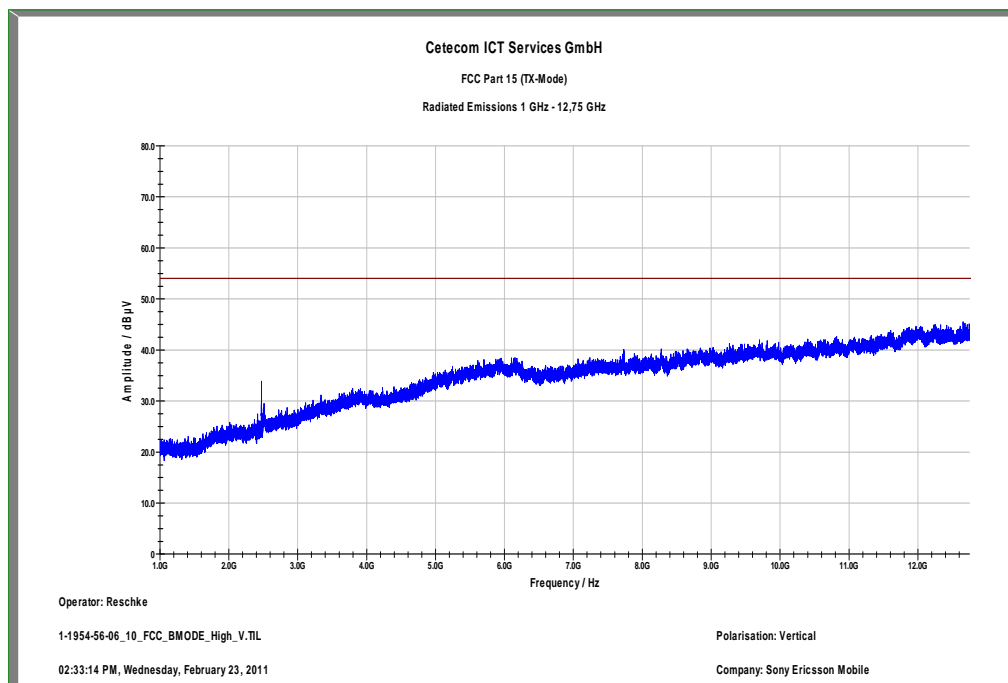

The carrier signal is notched with a 2.4 GHz band rejection filter.

Plot 13: Highest channel, 1 GHz to 12.75 GHz, horizontal polarization

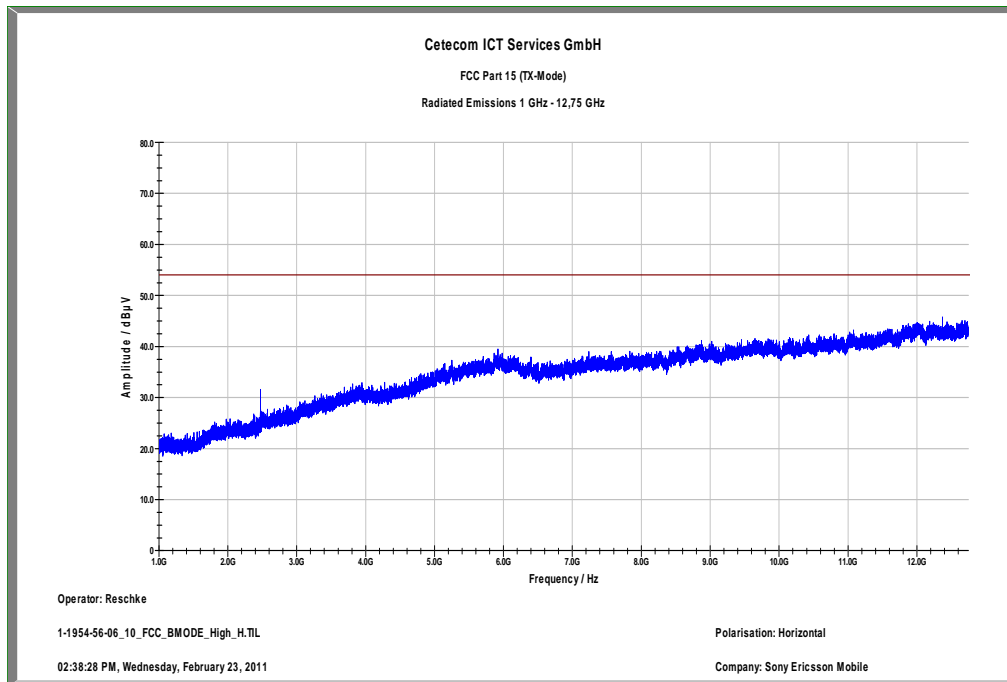

The carrier signal is notched with a 2.4 GHz band rejection filter.

Plot 14: Highest channel, 12.75 GHz to 18 GHz, vertical & horizontal polarization

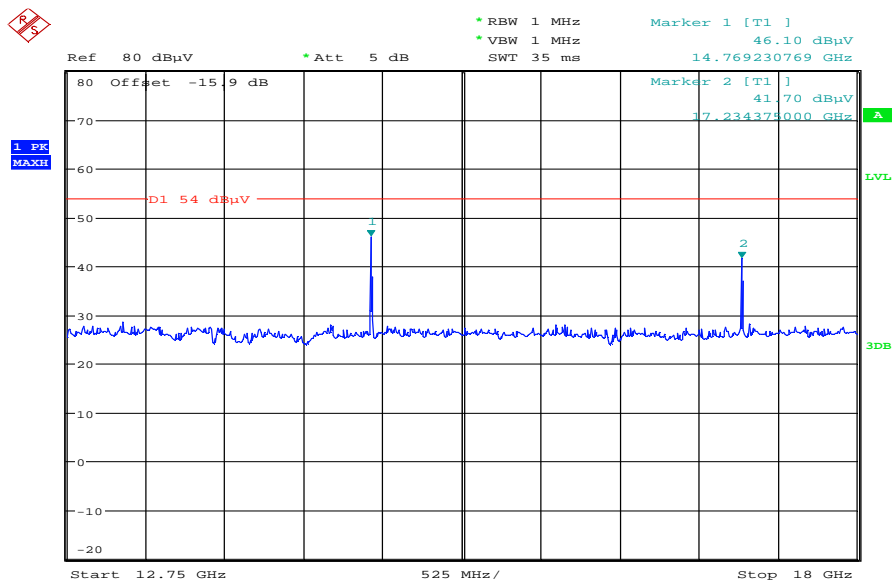

Date: 3.MAR.2011 10:07:28

Plot 15: Highest channel, 18 GHz to 26 GHz, vertical & horizontal polarization

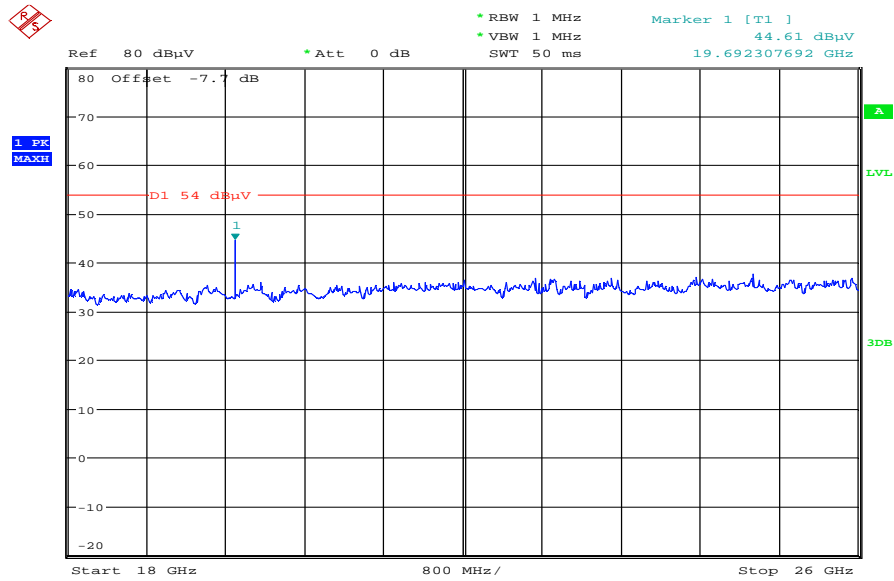

Date: 3.MAR.2011 10:21:25

Plots: OFDM / g – mode

Plot 1: Lowest channel, 30 MHz to 1 GHz, vertical & horizontal polarization

CETECOM ICT Services GmbH

Common Information

EUT: AAD-3880100-BV
 Serial Number: CB5A1CGN7M
 Test Description: FCC part 15 class B @ 10 m
 Operating Conditions: WLAN g & n-mode TX low channel + charging
 Operator Name: Hennemann
 Comment: AC: 115 V / 60 Hz

Scan Setup: STAN_Fin [EMI radiated]

Hardware Setup: Electric Field (NOS)
 Level Unit: dBµV/m

Subrange	Detectors	IF Bandwidth	Meas. Time	Receiver
30 MHz - 1,05 GHz	QuasiPeak	120 kHz	15 s	Receiver

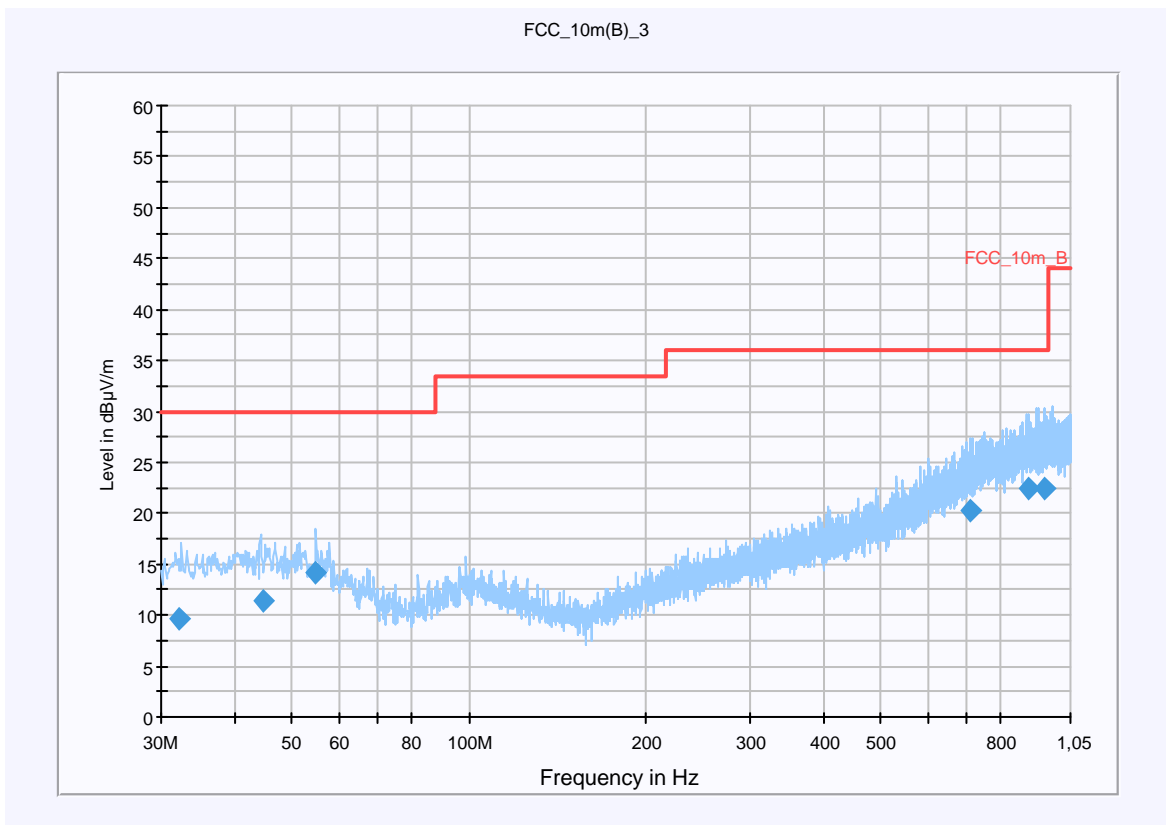

Final Result 1

Frequency (MHz)	QuasiPeak (dBµV/m)	Meas. Time (ms)	Bandwidth (kHz)	Antenna height (cm)	Polarity	Turntable position (deg)	Corr. (dB)	Margin (dB)	Limit (dBµV/m)	Comment
32.184750	9.6	15000.000	120.000	220.0	H	236.0	12.7	20.4	30.0	
44.785350	11.4	15000.000	120.000	98.0	V	151.0	13.3	18.6	30.0	
55.002900	14.2	15000.000	120.000	113.0	V	48.0	12.9	15.8	30.0	
708.827100	20.2	15000.000	120.000	213.0	H	301.0	22.7	15.8	36.0	
889.627350	22.4	15000.000	120.000	98.0	V	222.0	25.1	13.6	36.0	
948.390900	22.5	15000.000	120.000	220.0	H	160.0	25.3	13.5	36.0	

Hardware Setup: EMI radiated\Electric Field (NOS) - [EMI radiated]

Subrange 1	
Frequency Range:	30 MHz - 2 GHz
Receiver:	Receiver [ESCI 3] @ GPIB0 (ADR 20), SN 100083/003, FW 4.32
Signal Path:	without Notch FW 1.0
Antenna:	VULB 9163 SN 9163-295, FW --- Correction Table (vertical): VULP6113 Correction Table (horizontal): VULP6113 Correction Table: Cable_EN_1GHz (1005)
Antenna Tower:	Tower [EMCO 2090 Antenna Tower] @ GPIB0 (ADR 8), FW REV 3.12
Turntable:	Turntable [EMCO Turntable] @ GPIB0 (ADR 9), FW REV 3.12

EMC 32 Version 8.10.00

Plot 2: Lowest channel, 1 GHz to 12.75 GHz, vertical polarization

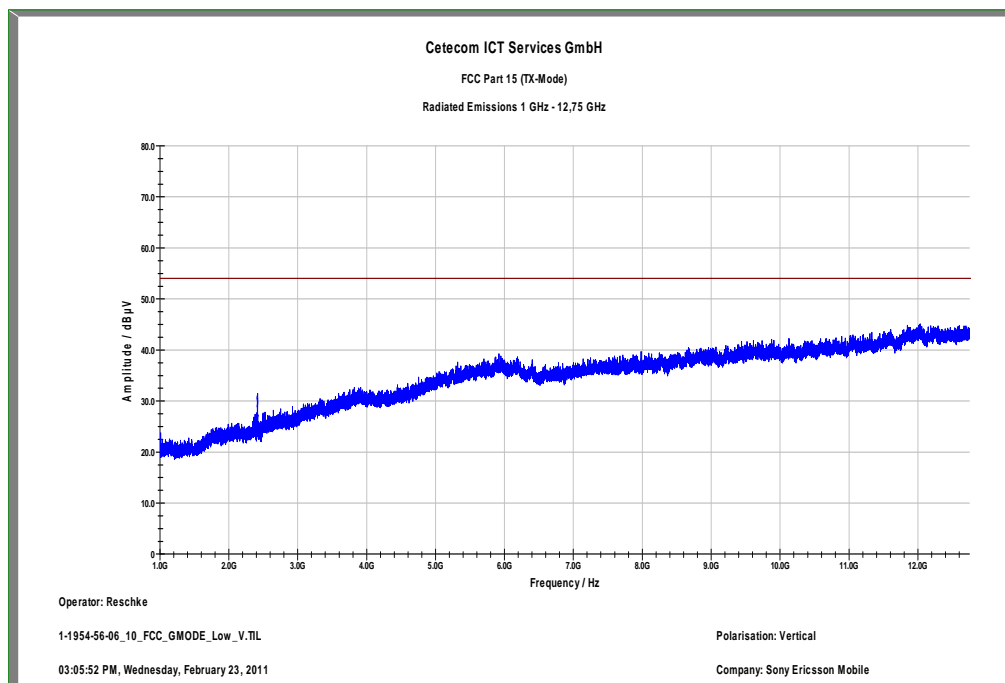

The carrier signal is notched with a 2.4 GHz band rejection filter.

Plot 3: Lowest channel, 1 GHz to 12.75 GHz, horizontal polarization

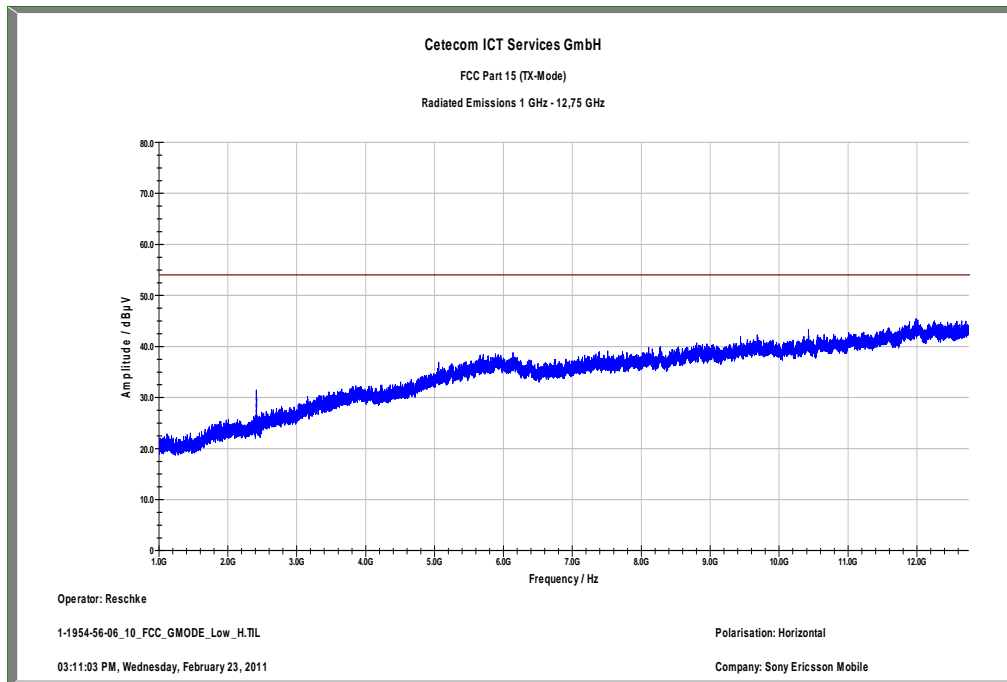

The carrier signal is notched with a 2.4 GHz band rejection filter.

Plot 4: Lowest channel, 12.75 GHz to 18 GHz, vertical & horizontal polarization

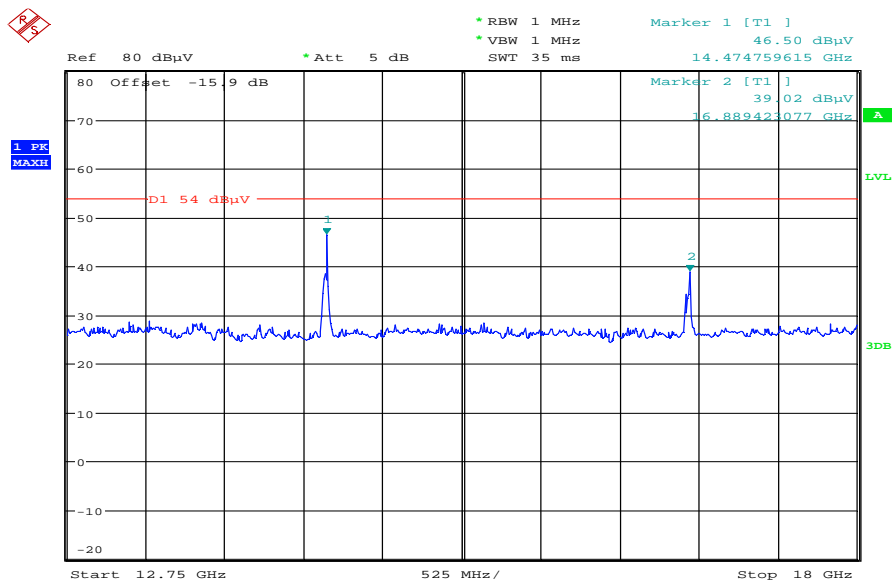

Date: 3.MAR.2011 10:02:06

Plot 5: Lowest channel, 18 GHz to 26 GHz, vertical & horizontal polarization

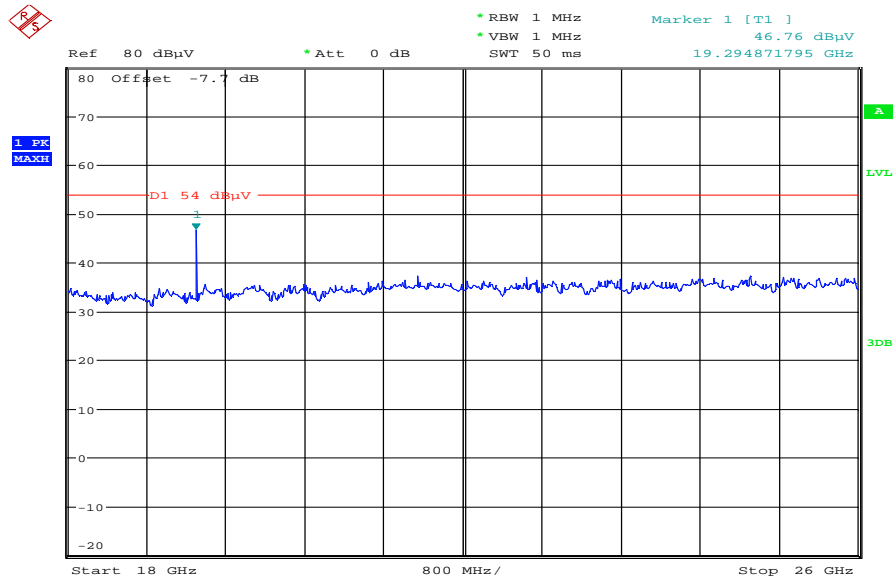

Date: 3.MAR.2011 10:16:39

Plot 6: Middle channel, 30 MHz to 1 GHz, vertical & horizontal polarization

CETECOM ICT Services GmbH

Common Information

EUT: AAD-3880100-BV
 Serial Number: CB5A1CGN7M
 Test Description: FCC part 15 class B @ 10 m
 Operating Conditions: WLAN g & n-mode TX mid channel + charging
 Operator Name: Hennemann
 Comment: AC: 115 V / 60 Hz

Scan Setup: STAN_Fin [EMI radiated]

Hardware Setup: Electric Field (NOS)
 Level Unit: dBµV/m

Subrange	Detectors	IF Bandwidth	Meas. Time	Receiver
30 MHz - 1,05 GHz	QuasiPeak	120 kHz	15 s	Receiver

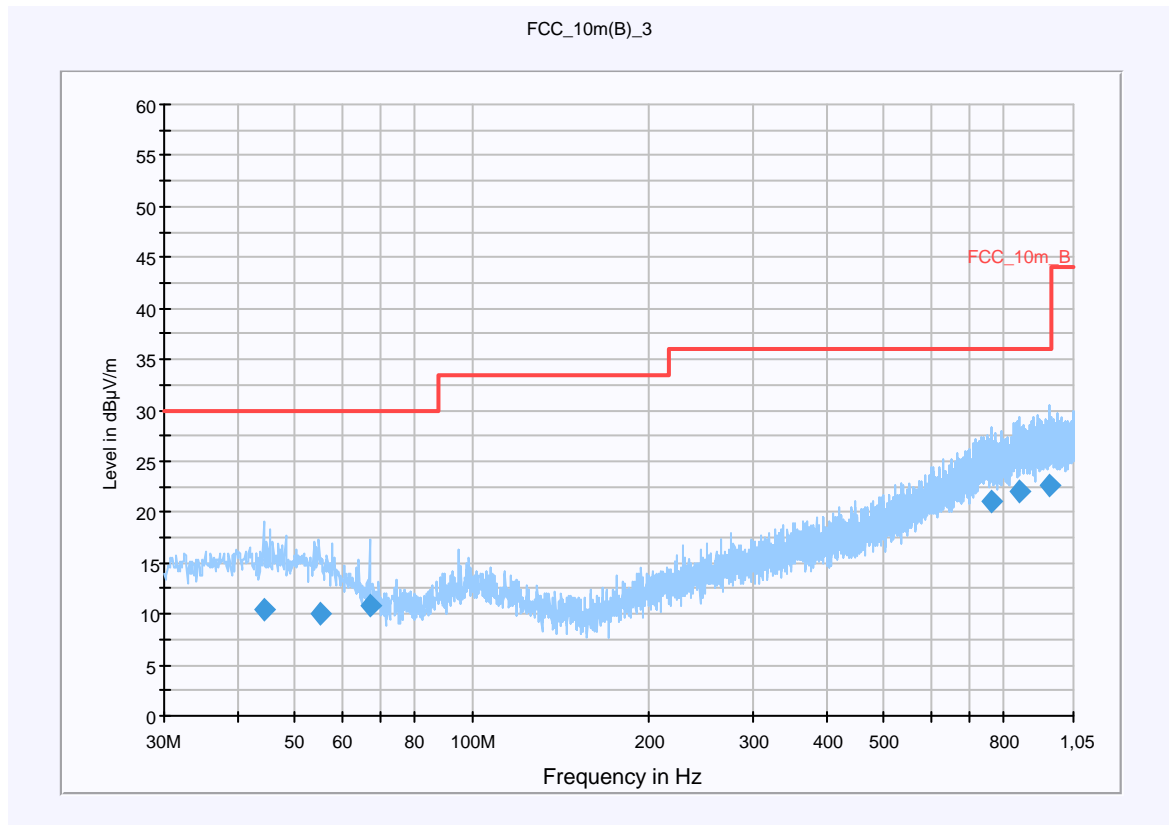

Final Result 1

Frequency (MHz)	QuasiPeak (dBµV/m)	Meas. Time (ms)	Bandwidth (kHz)	Antenna height (cm)	Polarity	Turntable position (deg)	Corr. (dB)	Margin (dB)	Limit (dBµV/m)	Comment
44.331000	10.4	15000.000	120.000	220.0	V	236.0	13.3	19.6	30.0	
55.380450	10.1	15000.000	120.000	98.0	V	133.0	12.8	19.9	30.0	
66.978750	10.8	15000.000	120.000	214.0	V	26.0	10.0	19.2	30.0	
761.086200	21.0	15000.000	120.000	220.0	H	236.0	23.7	15.0	36.0	
848.781450	22.0	15000.000	120.000	176.0	H	95.0	24.5	14.0	36.0	
955.356000	22.7	15000.000	120.000	98.0	H	52.0	25.4	13.3	36.0	

Hardware Setup: EMI radiated\Electric Field (NOS) - [EMI radiated]

Subrange 1	
Frequency Range:	30 MHz - 2 GHz
Receiver:	Receiver [ESCI 3] @ GPIB0 (ADR 20), SN 100083/003, FW 4.32
Signal Path:	without Notch FW 1.0
Antenna:	VULB 9163 SN 9163-295, FW --- Correction Table (vertical): VULP6113 Correction Table (horizontal): VULP6113 Correction Table: Cable_EN_1GHz (1005)
Antenna Tower:	Tower [EMCO 2090 Antenna Tower] @ GPIB0 (ADR 8), FW REV 3.12
Turntable:	Turntable [EMCO Turntable] @ GPIB0 (ADR 9), FW REV 3.12

EMC 32 Version 8.10.00

Plot 7: Middle channel, 1 GHz to 12.75 GHz, vertical polarization

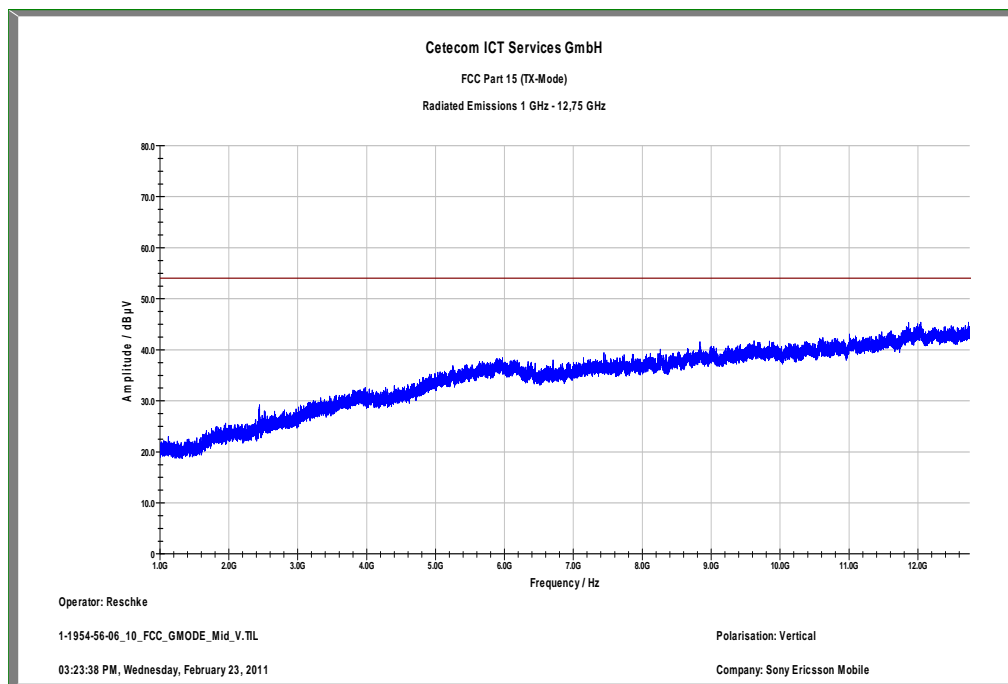

The carrier signal is notched with a 2.4 GHz band rejection filter.

Plot 8: Middle channel, 1 GHz to 12.75 GHz, horizontal polarization

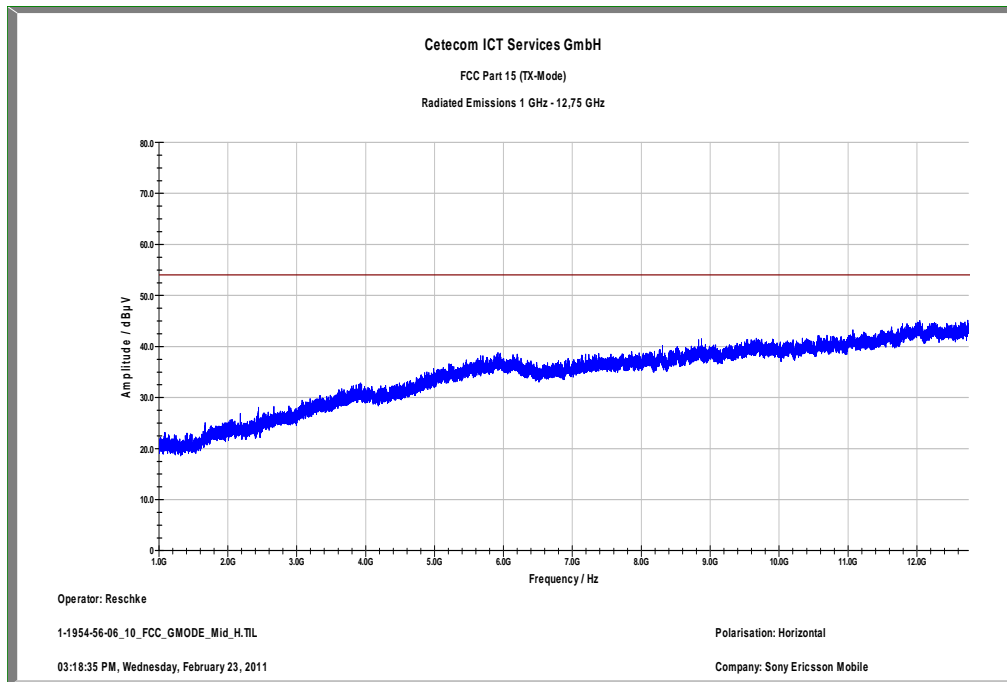

The carrier signal is notched with a 2.4 GHz band rejection filter.

Plot 9: Middle channel, 12.75 GHz to 18 GHz, vertical & horizontal polarization

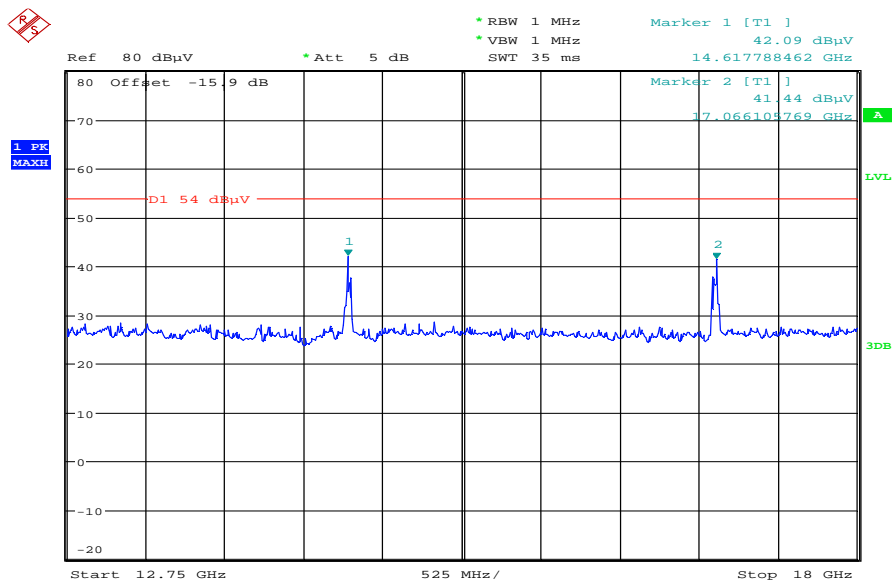

Date: 3.MAR.2011 10:05:29

Plot 10: Middle channel, 18 GHz to 26 GHz, vertical & horizontal polarization

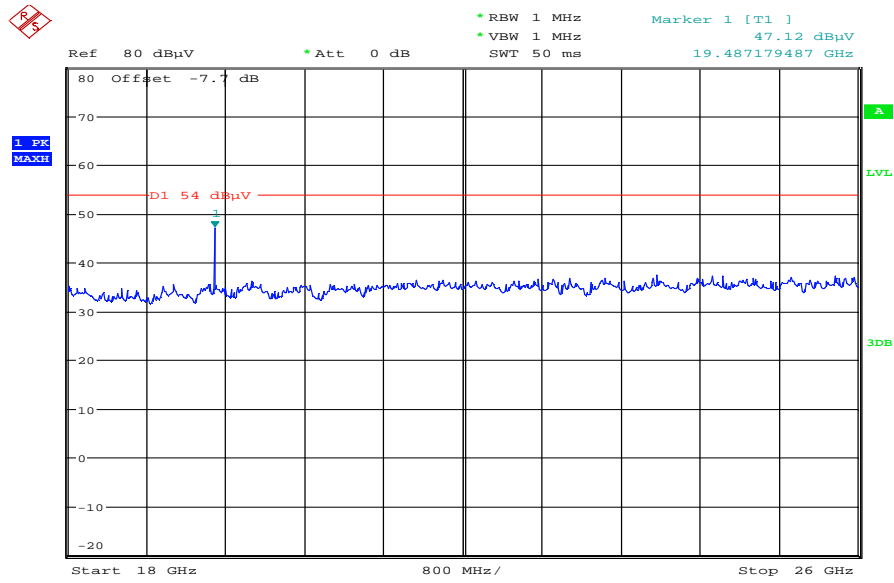

Date: 3.MAR.2011 10:19:12

Plot 11: Highest channel, 30 MHz to 1 GHz, vertical & horizontal polarization

CETECOM ICT Services GmbH

Common Information

EUT: AAD-3880100-BV
 Serial Number: CB5A1CGN7M
 Test Description: FCC part 15 class B @ 10 m
 Operating Conditions: WLAN g & n-mode TX up channel + charging
 Operator Name: Hennemann
 Comment: AC: 115 V / 60 Hz

Scan Setup: STAN_Fin [EMI radiated]

Hardware Setup: Electric Field (NOS)
 Level Unit: dBµV/m

Subrange	Detectors	IF Bandwidth	Meas. Time	Receiver
30 MHz - 1,05 GHz	QuasiPeak	120 kHz	15 s	Receiver

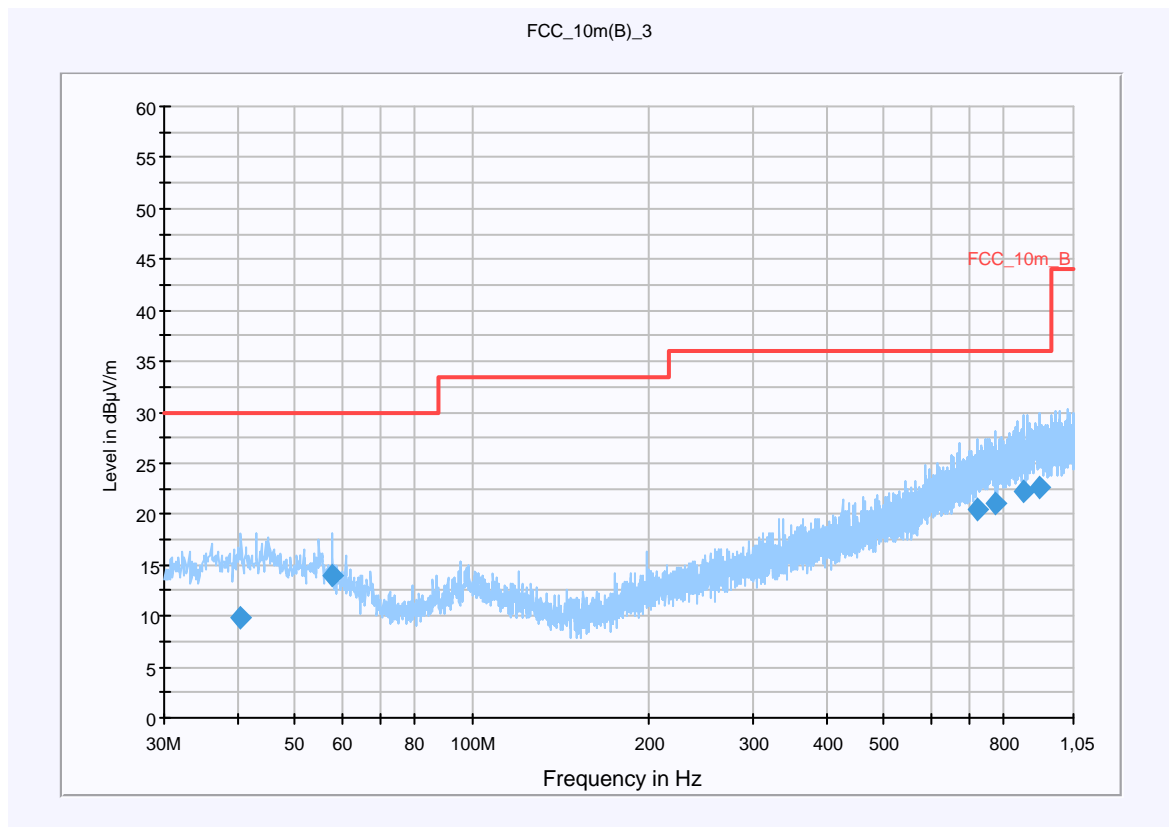

Final Result 1

Frequency (MHz)	QuasiPeak (dBµV/m)	Meas. Time (ms)	Bandwidth (kHz)	Antenna height (cm)	Polarity	Turntable position (deg)	Corr. (dB)	Margin (dB)	Limit (dBµV/m)	Comment
40.334400	9.8	15000.000	120.000	220.0	H	207.0	13.4	20.2	30.0	
57.996900	14.0	15000.000	120.000	220.0	V	93.0	12.1	16.0	30.0	
721.632750	20.5	15000.000	120.000	118.0	H	23.0	23.0	15.5	36.0	
776.133300	21.0	15000.000	120.000	186.0	V	160.0	23.7	15.0	36.0	
864.788400	22.2	15000.000	120.000	163.0	V	61.0	24.7	13.8	36.0	
922.094550	22.6	15000.000	120.000	220.0	H	183.0	25.3	13.4	36.0	

Hardware Setup: EMI radiated\Electric Field (NOS) - [EMI radiated]

Subrange 1	
Frequency Range:	30 MHz - 2 GHz
Receiver:	Receiver [ESCI 3] @ GPIB0 (ADR 20), SN 100083/003, FW 4.32
Signal Path:	without Notch FW 1.0
Antenna:	VULB 9163 SN 9163-295, FW --- Correction Table (vertical): VULP6113 Correction Table (horizontal): VULP6113 Correction Table: Cable_EN_1GHz (1005)
Antenna Tower:	Tower [EMCO 2090 Antenna Tower] @ GPIB0 (ADR 8), FW REV 3.12
Turntable:	Turntable [EMCO Turntable] @ GPIB0 (ADR 9), FW REV 3.12

EMC 32 Version 8.10.00

Plot 12: Highest channel, 1 GHz to 12.75 GHz, vertical polarization

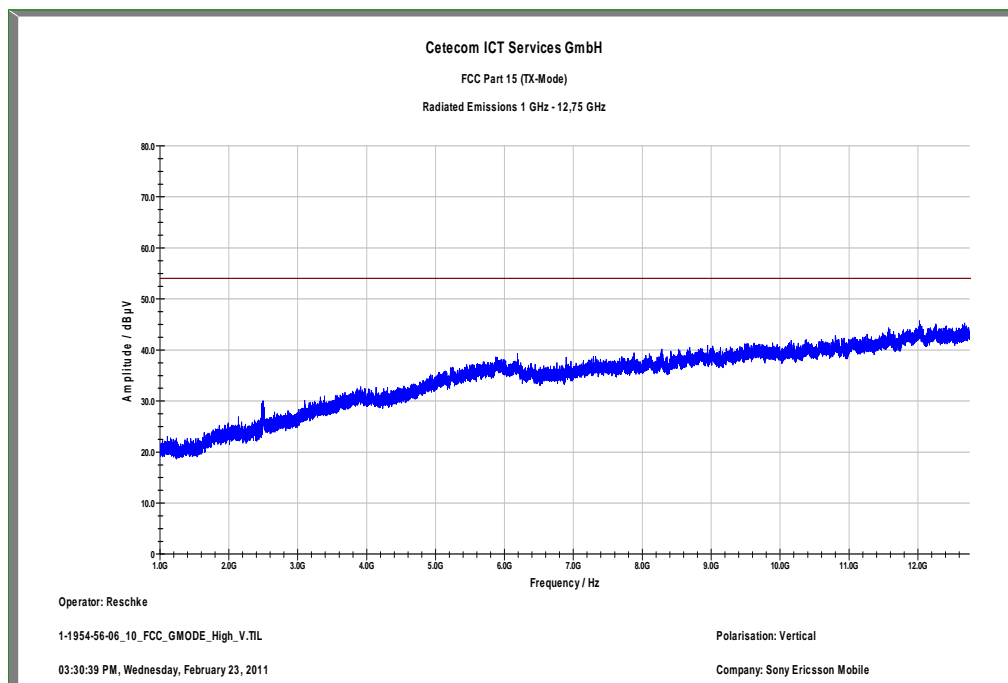

The carrier signal is notched with a 2.4 GHz band rejection filter.

Plot 13: Highest channel, 1 GHz to 12.75 GHz, horizontal polarization

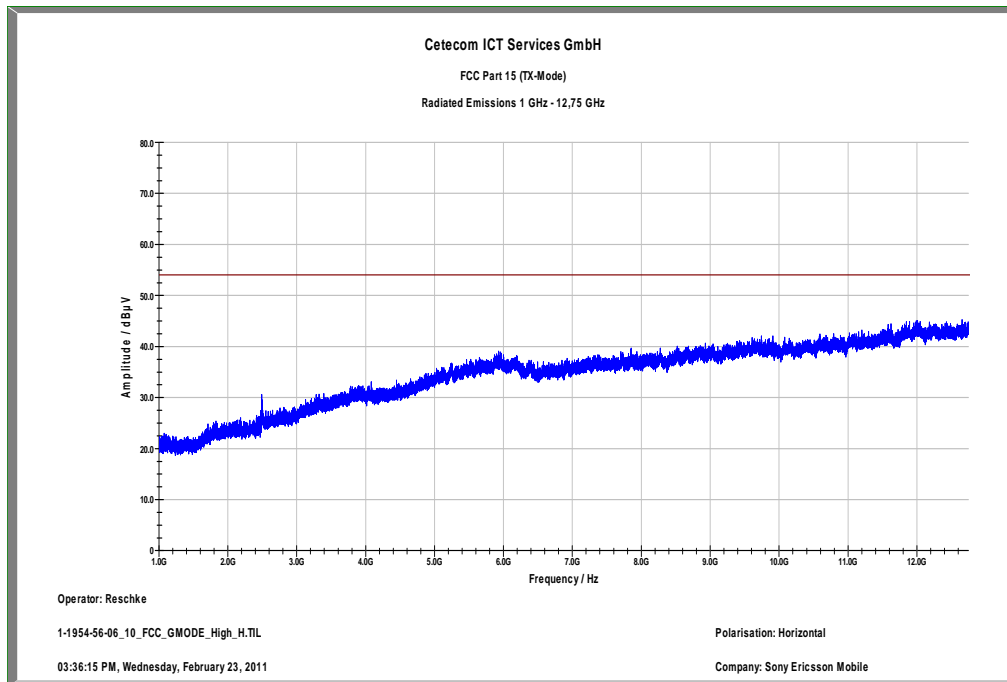

The carrier signal is notched with a 2.4 GHz band rejection filter.

Plot 14: Highest channel, 12.75 GHz to 18 GHz, vertical & horizontal polarization

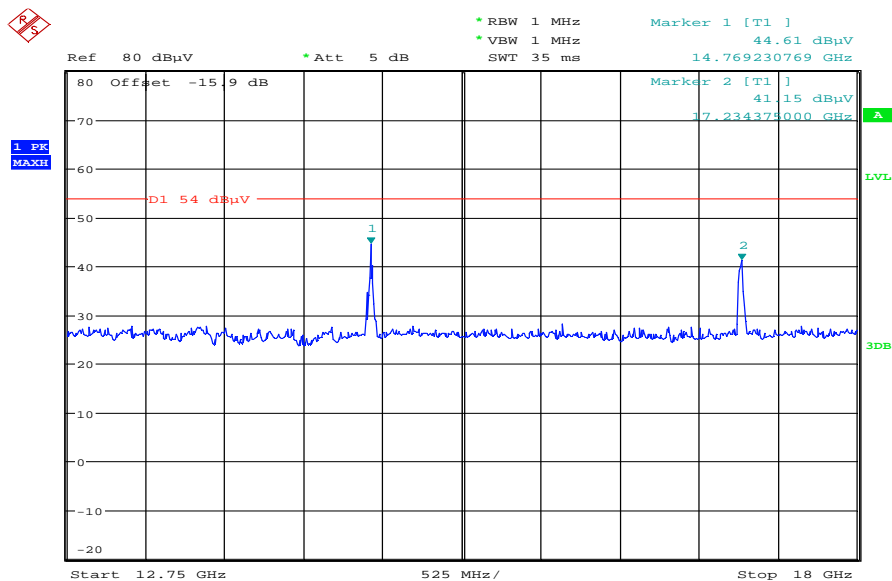

Date: 3.MAR.2011 10:08:08

Plot 15: Highest channel, 18 GHz to 26 GHz, vertical & horizontal polarization

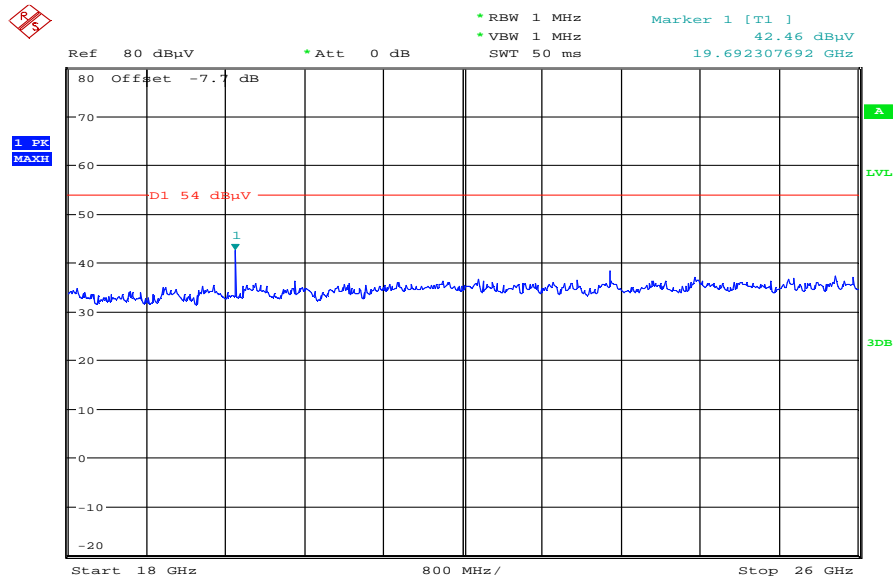

Date: 3.MAR.2011 10:22:07

Plots: OFDM / n – mode

Plot 1: Lowest channel, 30 MHz to 1 GHz, vertical & horizontal polarization

CETECOM ICT Services GmbH

Common Information

EUT: AAD-3880100-BV
 Serial Number: CB5A1CGN7M
 Test Description: FCC part 15 class B @ 10 m
 Operating Conditions: WLAN g & n-mode TX low channel + charging
 Operator Name: Hennemann
 Comment: AC: 115 V / 60 Hz

Scan Setup: STAN_Fin [EMI radiated]

Hardware Setup: Electric Field (NOS)
 Level Unit: dBµV/m

Subrange	Detectors	IF Bandwidth	Meas. Time	Receiver
30 MHz - 1,05 GHz	QuasiPeak	120 kHz	15 s	Receiver

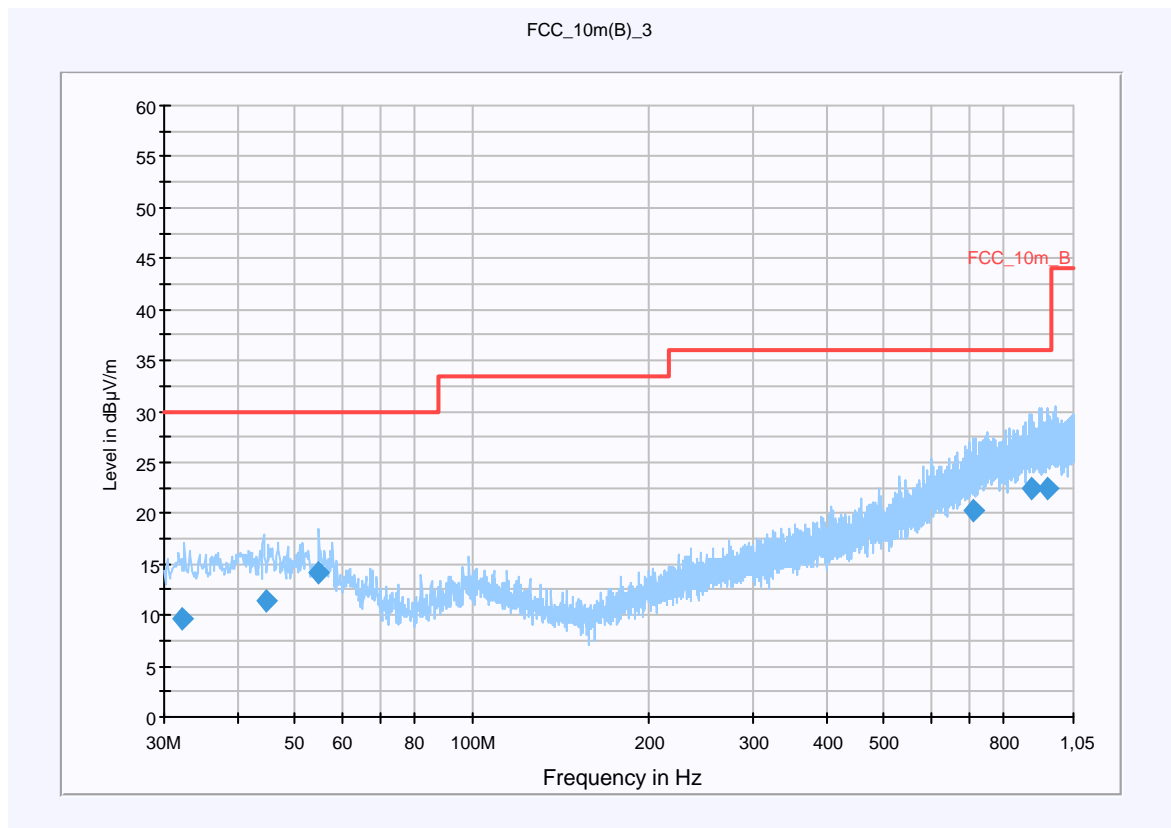

Final Result 1

Frequency (MHz)	QuasiPeak (dBµV/m)	Meas. Time (ms)	Bandwidth (kHz)	Antenna height (cm)	Polarity	Turntable position (deg)	Corr. (dB)	Margin (dB)	Limit (dBµV/m)	Comment
32.184750	9.6	15000.000	120.000	220.0	H	236.0	12.7	20.4	30.0	
44.785350	11.4	15000.000	120.000	98.0	V	151.0	13.3	18.6	30.0	
55.002900	14.2	15000.000	120.000	113.0	V	48.0	12.9	15.8	30.0	
708.827100	20.2	15000.000	120.000	213.0	H	301.0	22.7	15.8	36.0	
889.627350	22.4	15000.000	120.000	98.0	V	222.0	25.1	13.6	36.0	
948.390900	22.5	15000.000	120.000	220.0	H	160.0	25.3	13.5	36.0	

Hardware Setup: EMI radiated\Electric Field (NOS) - [EMI radiated]

Subrange 1	
Frequency Range:	30 MHz - 2 GHz
Receiver:	Receiver [ESCI 3] @ GPIB0 (ADR 20), SN 100083/003, FW 4.32
Signal Path:	without Notch FW 1.0
Antenna:	VULB 9163 SN 9163-295, FW --- Correction Table (vertical): VULP6113 Correction Table (horizontal): VULP6113 Correction Table: Cable_EN_1GHz (1005)
Antenna Tower:	Tower [EMCO 2090 Antenna Tower] @ GPIB0 (ADR 8), FW REV 3.12
Turntable:	Turntable [EMCO Turntable] @ GPIB0 (ADR 9), FW REV 3.12

EMC 32 Version 8.10.00

Plot 2: Lowest channel, 1 GHz to 12.75 GHz, vertical polarization

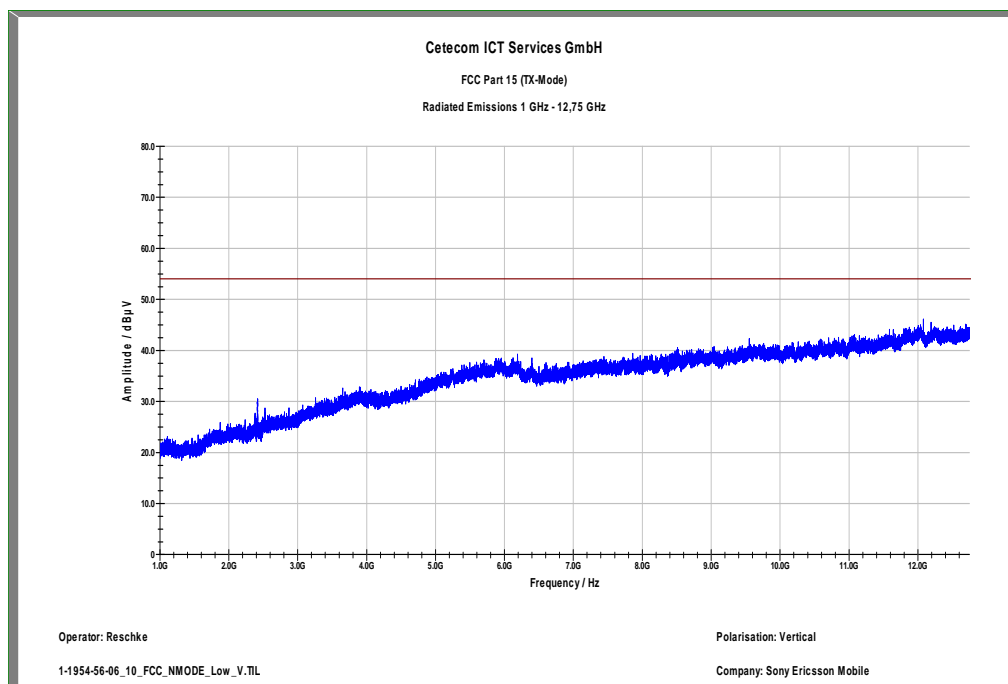

The carrier signal is notched with a 2.4 GHz band rejection filter.

Plot 3: Lowest channel, 1 GHz to 12.75 GHz, horizontal polarization

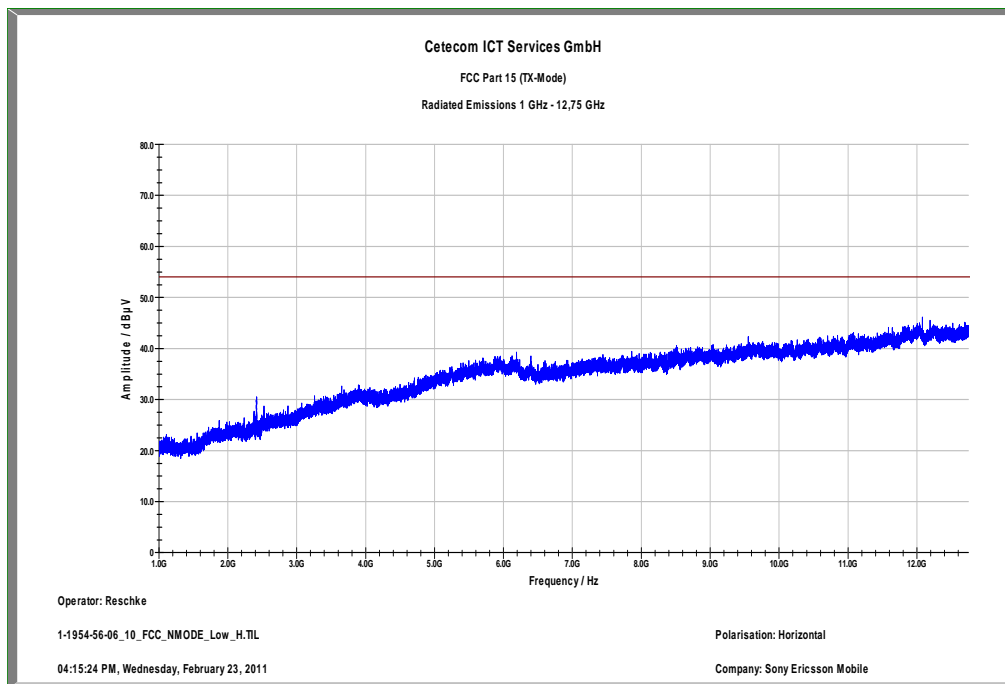

The carrier signal is notched with a 2.4 GHz band rejection filter.

Plot 4: Lowest channel, 12.75 GHz to 18 GHz, vertical & horizontal polarization

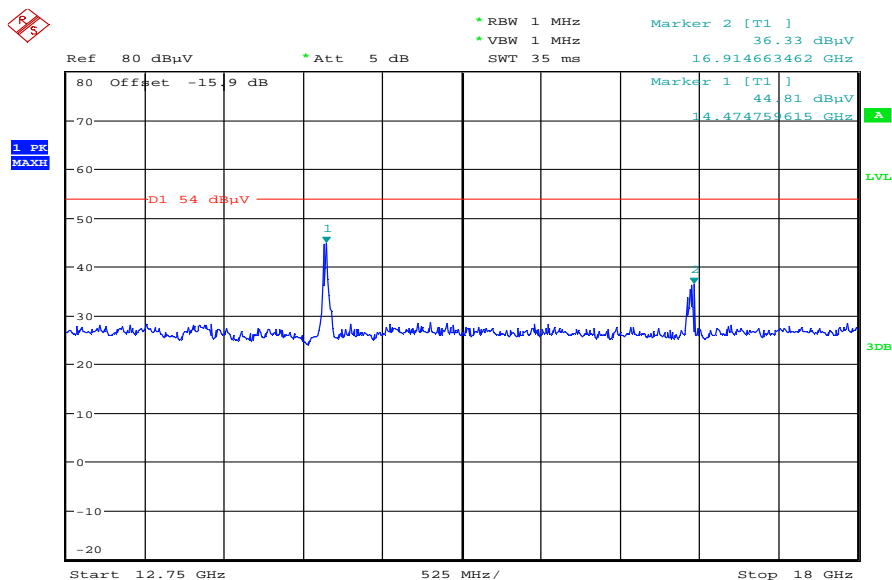

Date: 3.MAR.2011 10:03:11

Plot 5: Lowest channel, 18 GHz to 26 GHz, vertical & horizontal polarization

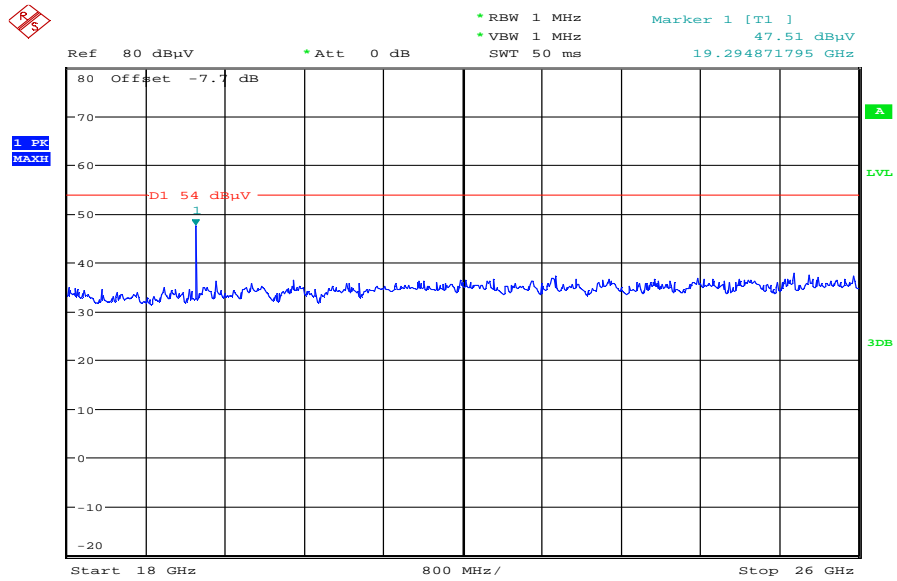

Date: 3.MAR.2011 10:17:19

Plot 6: Middle channel, 30 MHz to 1 GHz, vertical & horizontal polarization

CETECOM ICT Services GmbH

Common Information

EUT: AAD-3880100-BV
 Serial Number: CB5A1CGN7M
 Test Description: FCC part 15 class B @ 10 m
 Operating Conditions: WLAN g & n-mode TX mid channel + charging
 Operator Name: Hennemann
 Comment: AC: 115 V / 60 Hz

Scan Setup: STAN_Fin [EMI radiated]

Hardware Setup: Electric Field (NOS)
 Level Unit: dB μ V/m

Subrange	Detectors	IF Bandwidth	Meas. Time	Receiver
30 MHz - 1,05 GHz	QuasiPeak	120 kHz	15 s	Receiver

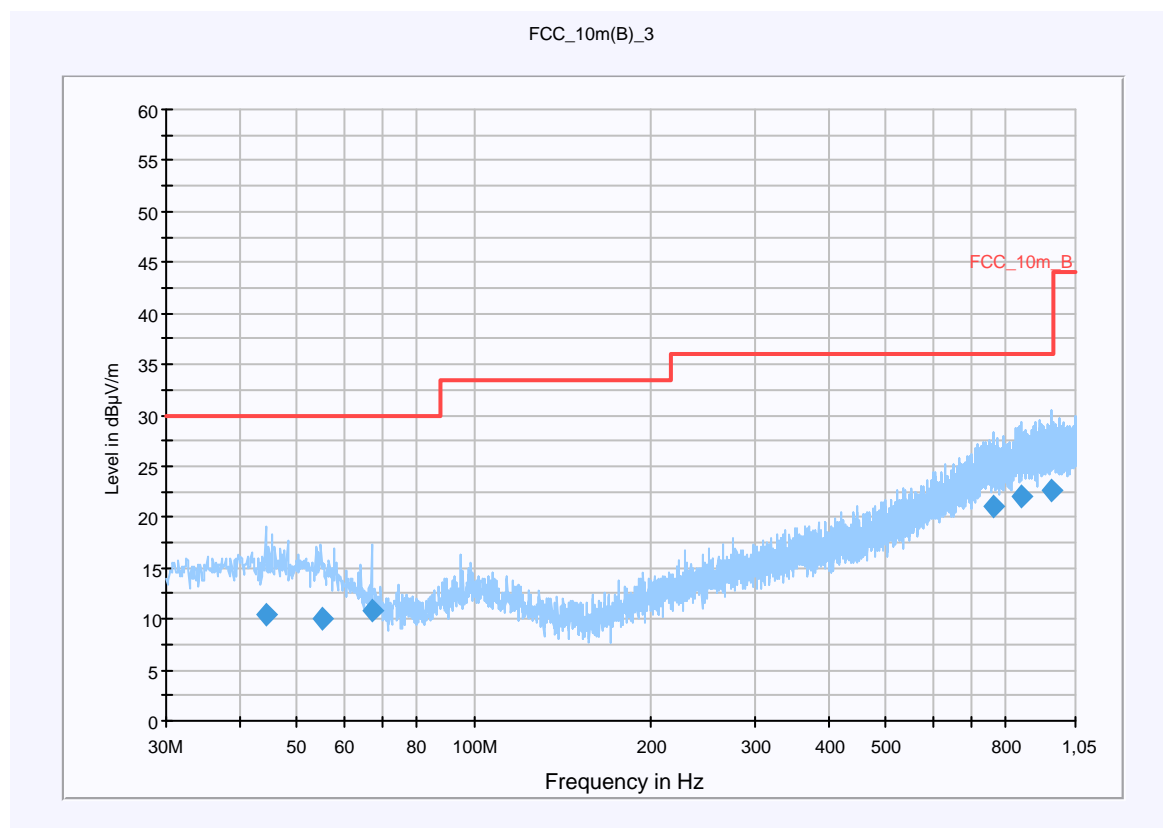

Final Result 1

Frequency (MHz)	QuasiPeak (dB μ V/m)	Meas. Time (ms)	Bandwidth (kHz)	Antenna height (cm)	Polarity	Turntable position (deg)	Corr. (dB)	Margin (dB)	Limit (dB μ V/m)	Comment
44.331000	10.4	15000.000	120.000	220.0	V	236.0	13.3	19.6	30.0	
55.380450	10.1	15000.000	120.000	98.0	V	133.0	12.8	19.9	30.0	
66.978750	10.8	15000.000	120.000	214.0	V	26.0	10.0	19.2	30.0	
761.086200	21.0	15000.000	120.000	220.0	H	236.0	23.7	15.0	36.0	
848.781450	22.0	15000.000	120.000	176.0	H	95.0	24.5	14.0	36.0	
955.356000	22.7	15000.000	120.000	98.0	H	52.0	25.4	13.3	36.0	

Hardware Setup: EMI radiated\Electric Field (NOS) - [EMI radiated]

Subrange 1	
Frequency Range:	30 MHz - 2 GHz
Receiver:	Receiver [ESCI 3] @ GPIB0 (ADR 20), SN 100083/003, FW 4.32
Signal Path:	without Notch FW 1.0
Antenna:	VULB 9163 SN 9163-295, FW --- Correction Table (vertical): VULP6113 Correction Table (horizontal): VULP6113 Correction Table: Cable_EN_1GHz (1005)
Antenna Tower:	Tower [EMCO 2090 Antenna Tower] @ GPIB0 (ADR 8), FW REV 3.12
Turntable:	Turntable [EMCO Turntable] @ GPIB0 (ADR 9), FW REV 3.12

EMC 32 Version 8.10.00

Plot 7: Middle channel, 1 GHz to 12.75 GHz, vertical polarization

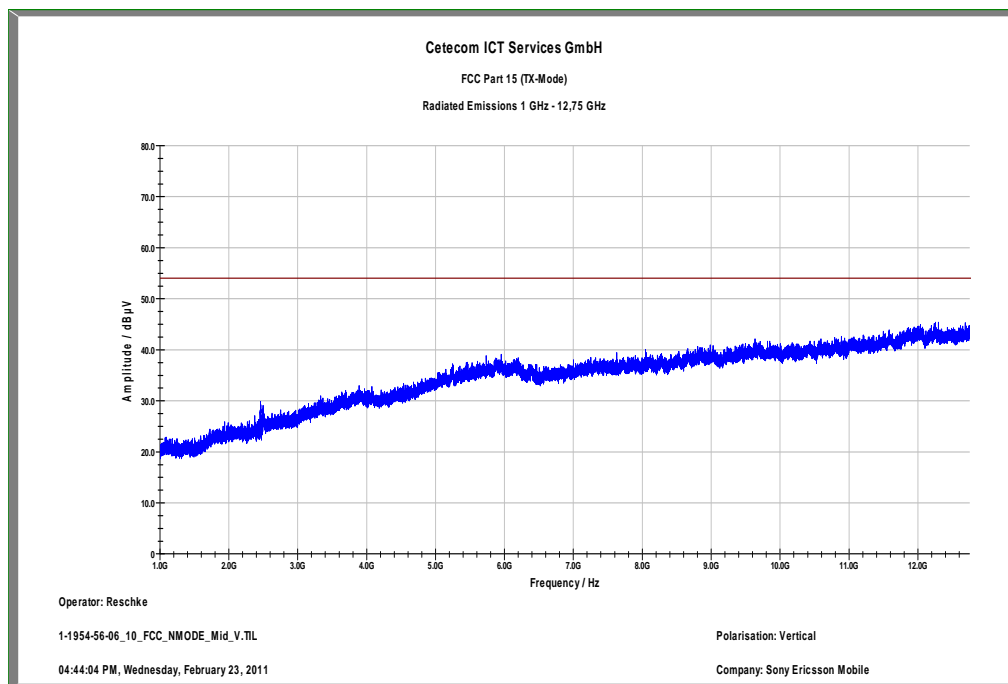

The carrier signal is notched with a 2.4 GHz band rejection filter.

Plot 8: Middle channel, 1 GHz to 12.75 GHz, horizontal polarization

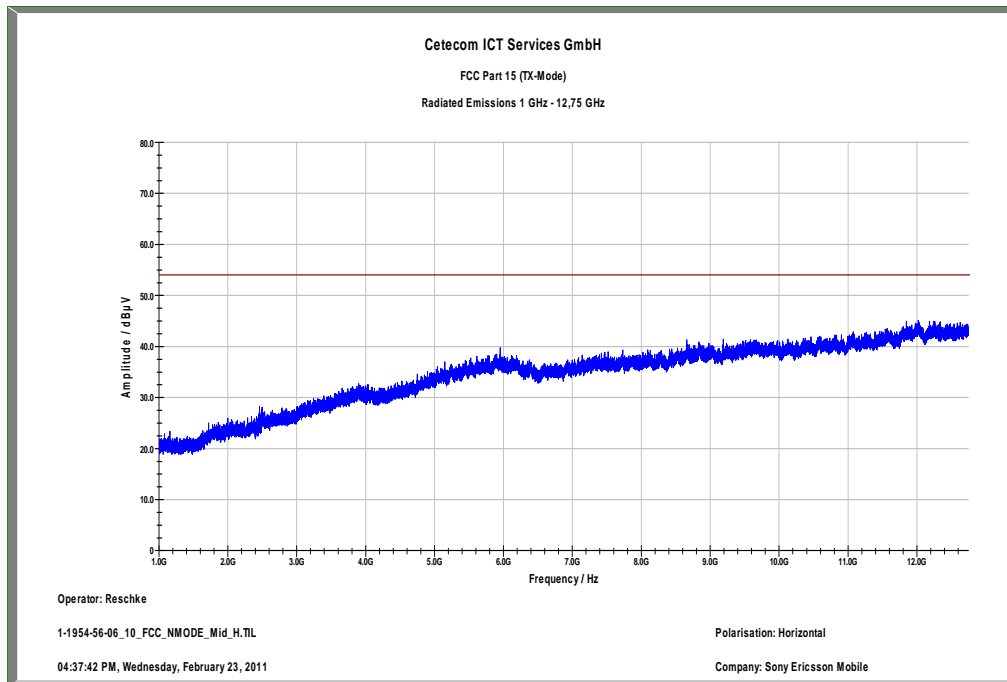

The carrier signal is notched with a 2.4 GHz band rejection filter.

Plot 9: Middle channel, 12.75 GHz to 18 GHz, vertical & horizontal polarization

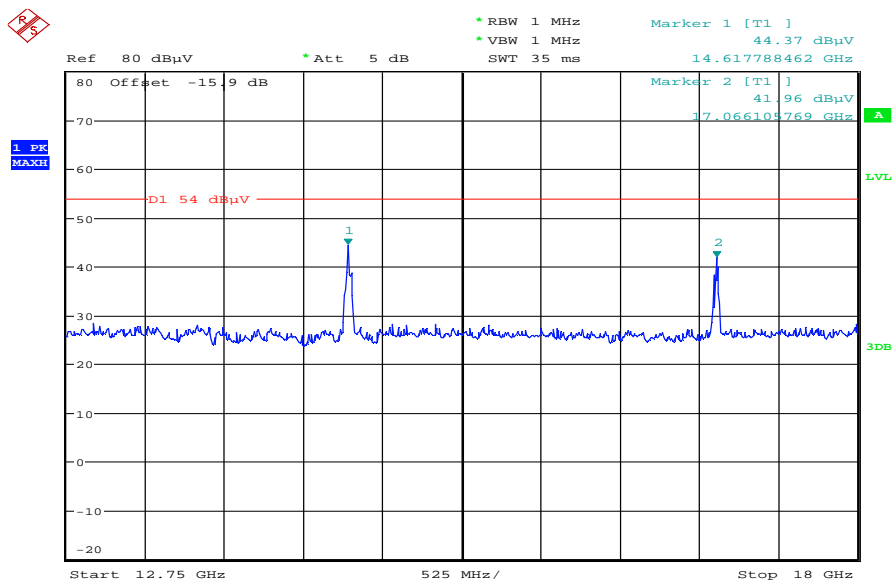

Date: 3.MAR.2011 10:06:13

Plot 10: Middle channel, 18 GHz to 26 GHz, vertical & horizontal polarization

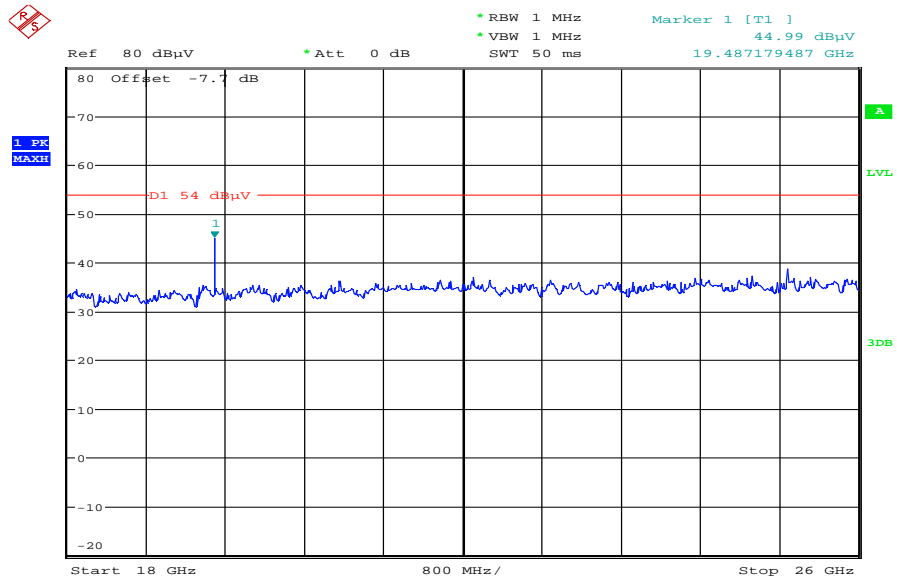

Date: 3.MAR.2011 10:20:37

Plot 11: Highest channel, 30 MHz to 1 GHz, vertical & horizontal polarization

CETECOM ICT Services GmbH

Common Information

EUT: AAD-3880100-BV
 Serial Number: CB5A1CGN7M
 Test Description: FCC part 15 class B @ 10 m
 Operating Conditions: WLAN g & n-mode TX up channel + charging
 Operator Name: Hennemann
 Comment: AC: 115 V / 60 Hz

Scan Setup: STAN_Fin [EMI radiated]

Hardware Setup: Electric Field (NOS)
 Level Unit: dBµV/m

Subrange	Detectors	IF Bandwidth	Meas. Time	Receiver
30 MHz - 1,05 GHz	QuasiPeak	120 kHz	15 s	Receiver

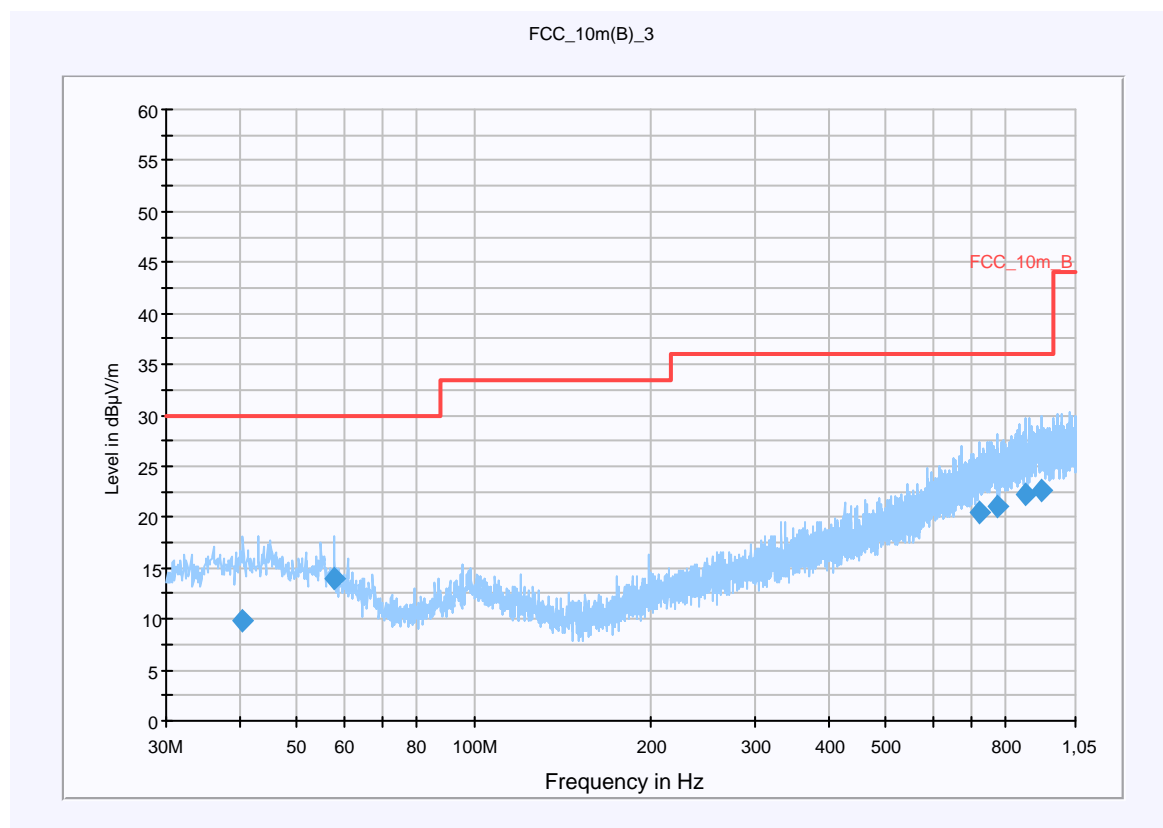

Final Result 1

Frequency (MHz)	QuasiPeak (dBµV/m)	Meas. Time (ms)	Bandwidth (kHz)	Antenna height (cm)	Polarity	Turntable position (deg)	Corr. (dB)	Margin (dB)	Limit (dBµV/m)	Comment
40.334400	9.8	15000.000	120.000	220.0	H	207.0	13.4	20.2	30.0	
57.996900	14.0	15000.000	120.000	220.0	V	93.0	12.1	16.0	30.0	
721.632750	20.5	15000.000	120.000	118.0	H	23.0	23.0	15.5	36.0	
776.133300	21.0	15000.000	120.000	186.0	V	160.0	23.7	15.0	36.0	
864.788400	22.2	15000.000	120.000	163.0	V	61.0	24.7	13.8	36.0	
922.094550	22.6	15000.000	120.000	220.0	H	183.0	25.3	13.4	36.0	

Hardware Setup: EMI radiated\Electric Field (NOS) - [EMI radiated]

Subrange 1	
Frequency Range:	30 MHz - 2 GHz
Receiver:	Receiver [ESCI 3] @ GPIB0 (ADR 20), SN 100083/003, FW 4.32
Signal Path:	without Notch FW 1.0
Antenna:	VULB 9163 SN 9163-295, FW --- Correction Table (vertical): VULP6113 Correction Table (horizontal): VULP6113 Correction Table: Cable_EN_1GHz (1005)
Antenna Tower:	Tower [EMCO 2090 Antenna Tower] @ GPIB0 (ADR 8), FW REV 3.12
Turntable:	Turntable [EMCO Turntable] @ GPIB0 (ADR 9), FW REV 3.12

EMC 32 Version 8.10.00

Plot 12: Highest channel, 1 GHz to 12.75 GHz, vertical polarization

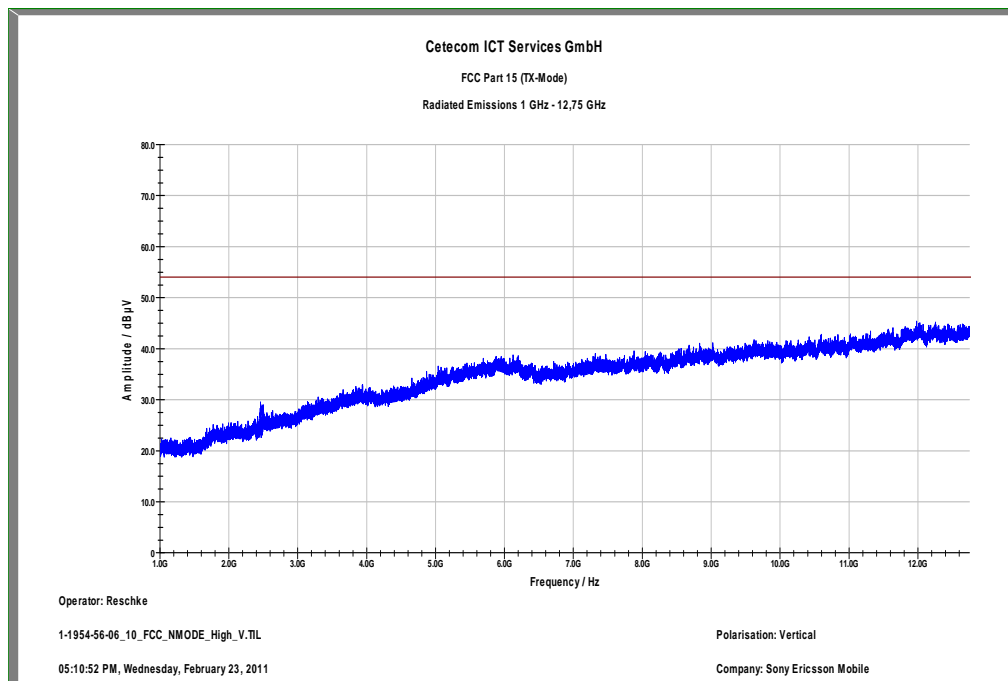

The carrier signal is notched with a 2.4 GHz band rejection filter.

Plot 13: Highest channel, 1 GHz to 12.75 GHz, horizontal polarization

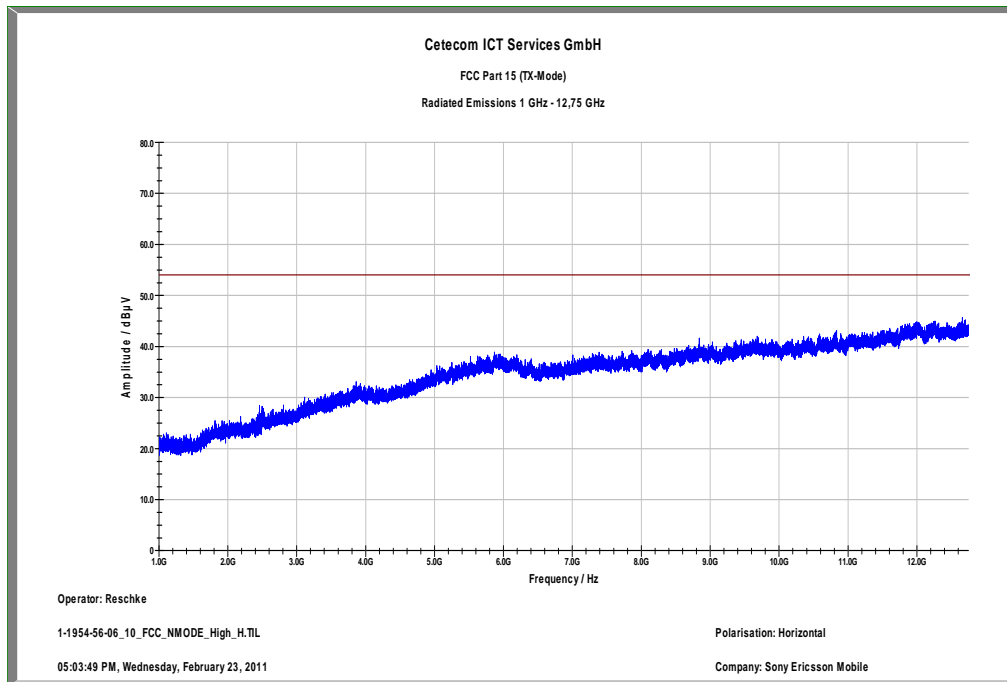

The carrier signal is notched with a 2.4 GHz band rejection filter.

Plot 14: Highest channel, 12.75 GHz to 18 GHz, vertical & horizontal polarization

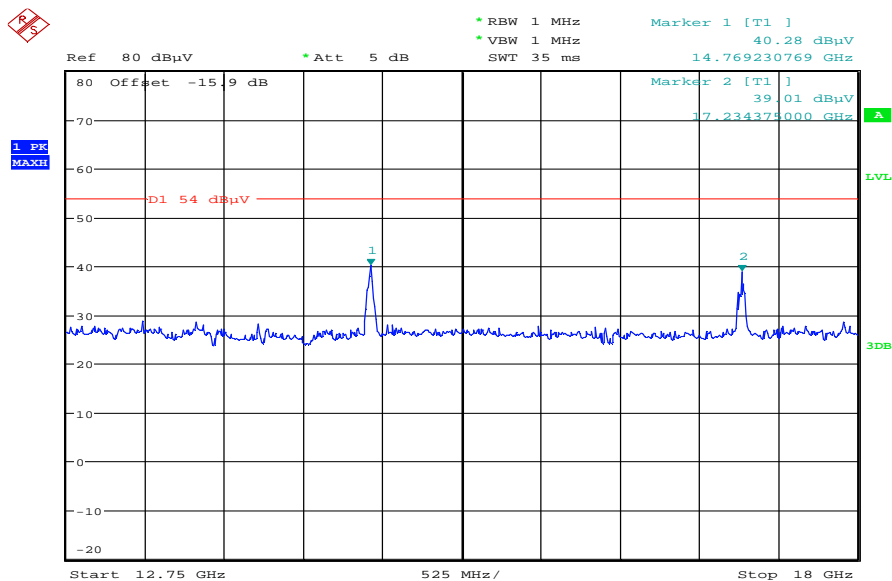

Date: 3.MAR.2011 10:09:01

Plot 15: Highest channel, 18 GHz to 26 GHz, vertical & horizontal polarization

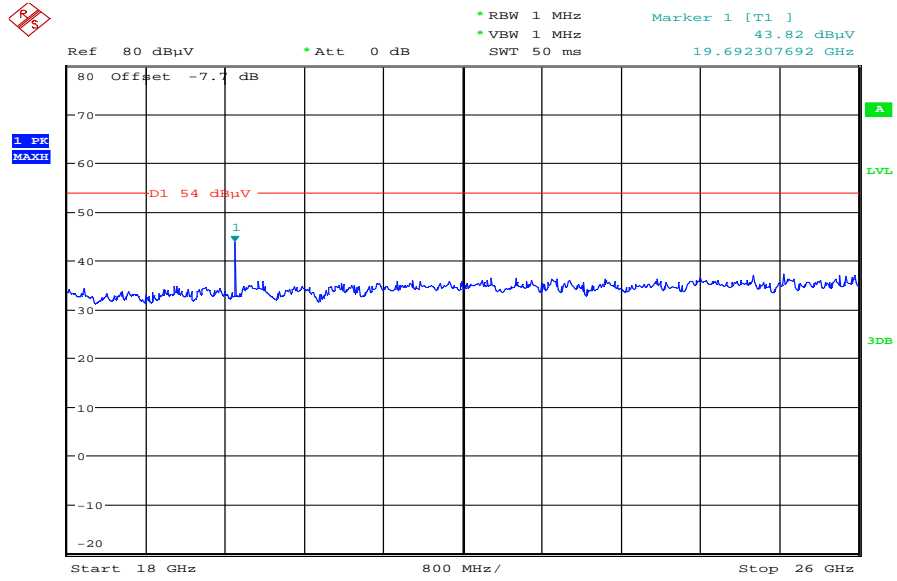

Date: 3.MAR.2011 10:22:48

9.11 RX spurious emissions radiated

Description:

Measurement of the radiated spurious emissions in idle/receive mode. The results are valid for both modes.

Measurement:

Measurement parameter	
Detector:	Peak / Quasi Peak
Sweep time:	Auto
Video bandwidth:	Sweep: 100 kHz Remeasurement: 10 Hz
Resolution bandwidth:	F < 1 GHz: 100 kHz F > 1 GHz: 1 MHz
Span:	30 MHz to 25 GHz
Trace-Mode:	Max Hold

Limits:

FCC		IC
CFR Part 15.109		RSS Gen, Issue 2, 4.10
RX Spurious Emissions Radiated		
Frequency (MHz)	Field Strength (dB μ V/m)	Measurement distance
30 - 88	30.0	10
88 – 216	33.5	10
216 – 960	36.0	10
Above 960	54.0	3

Results:

RX Spurious Emissions Radiated [dB μ V/m]		
F [MHz]	Detector	Level [dB μ V/m]
For emissions below 1 GHz, please take a look at the table below the 1 GHz plot.		
No critical peaks detected between 1 GHz and 12.75 GHz.		
For emissions above 12.75 GHz, please take a look at the plots.		
Measurement uncertainty	± 3 dB	

Result: The result of the measurement is passed.

Plots: RX / Idle – mode

Plot 1: 30 MHz to 1 GHz, vertical & horizontal polarization

CETECOM ICT Services GmbH

Common Information

EUT: AAD-3880100-BV
 Serial Number: CB5A1CGN7M
 Test Description: FCC part 15 class B @ 10 m
 Operating Conditions: WLAN idle + charging
 Operator Name: Hennemann
 Comment: AC: 115 V / 60 Hz

Scan Setup: STAN_Fin [EMI radiated]

Hardware Setup: Electric Field (NOS)
 Level Unit: dBµV/m

Subrange	Detectors	IF Bandwidth	Meas. Time	Receiver
30 MHz - 1,05 GHz	QuasiPeak	120 kHz	15 s	Receiver

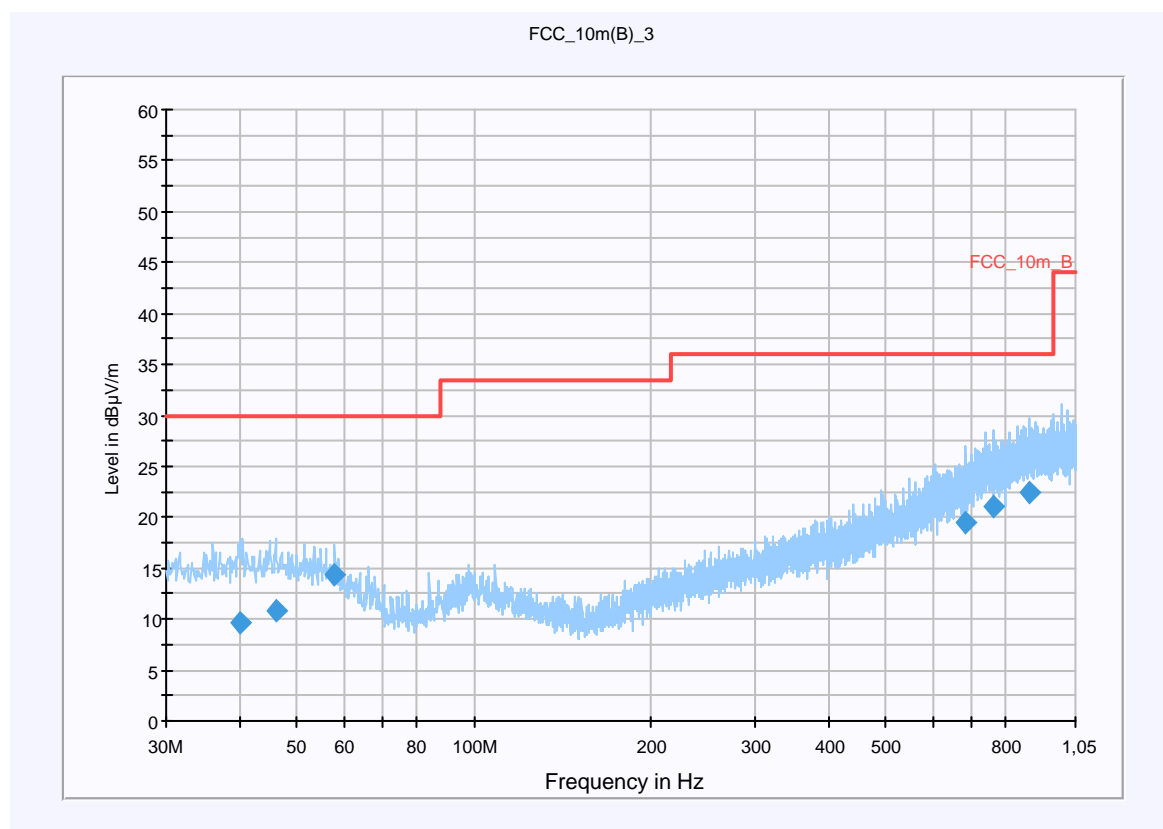

Final Result 1

Frequency (MHz)	QuasiPeak (dBµV/m)	Meas. Time (ms)	Bandwidth (kHz)	Antenna height (cm)	Polarity	Turntable position (deg)	Corr. (dB)	Margin (dB)	Limit (dBµV/m)	Comment
40.097400	9.6	15000.000	120.000	220.0	H	-5.0	13.4	20.4	30.0	
46.086150	10.9	15000.000	120.000	220.0	V	126.0	13.3	19.1	30.0	
58.009950	14.4	15000.000	120.000	98.0	V	275.0	12.1	15.6	30.0	
682.575600	19.4	15000.000	120.000	220.0	V	160.0	22.0	16.6	36.0	
761.669250	21.1	15000.000	120.000	220.0	V	48.0	23.7	14.9	36.0	
880.359150	22.4	15000.000	120.000	220.0	V	183.0	24.9	13.6	36.0	

Hardware Setup: EMI radiated\Electric Field (NOS) - [EMI radiated]

Subrange 1	
Frequency Range:	30 MHz - 2 GHz
Receiver:	Receiver [ESCI 3] @ GPIB0 (ADR 20), SN 100083/003, FW 4.32
Signal Path:	without Notch FW 1.0
Antenna:	VULB 9163 SN 9163-295, FW --- Correction Table (vertical): VULP6113 Correction Table (horizontal): VULP6113 Correction Table: Cable_EN_1GHz (1005)
Antenna Tower:	Tower [EMCO 2090 Antenna Tower] @ GPIB0 (ADR 8), FW REV 3.12
Turntable:	Turntable [EMCO Turntable] @ GPIB0 (ADR 9), FW REV 3.12

EMC 32 Version 8.10.00

Plot 2: 1 GHz to 12.75 GHz, vertical polarization

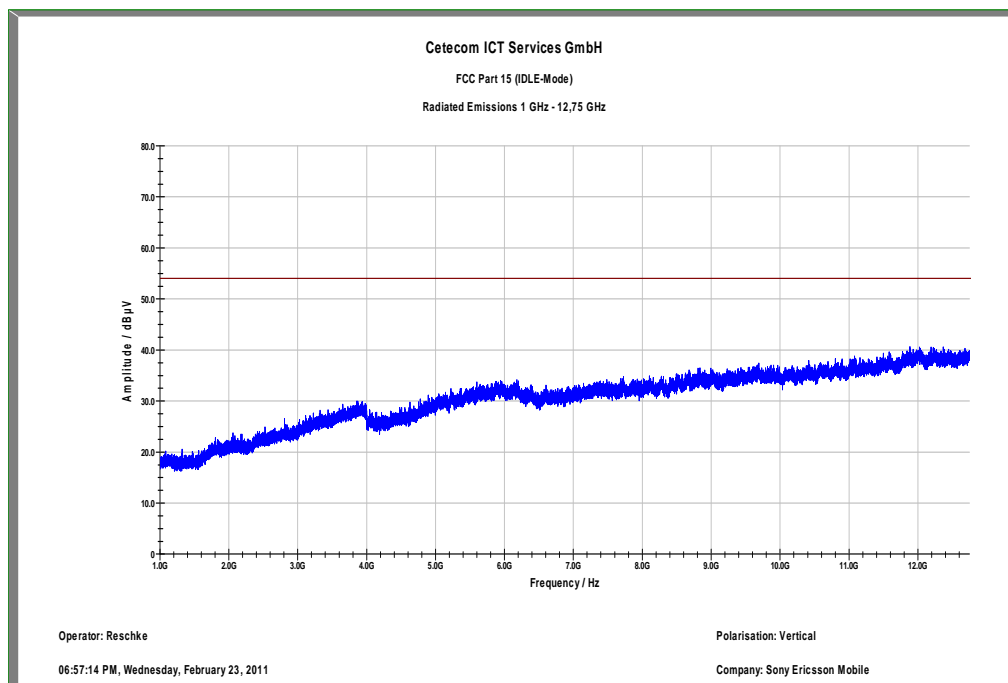

Plot 3: 1 GHz to 12.75 GHz, horizontal polarization

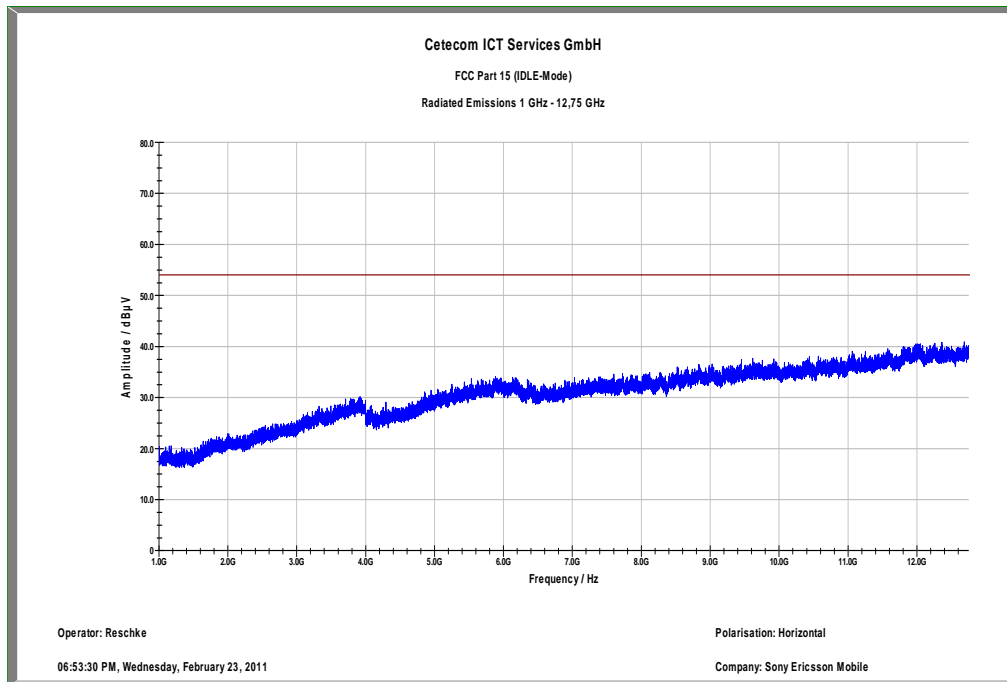

Plot 4: 12.75 GHz to 18 GHz, vertical & horizontal polarization

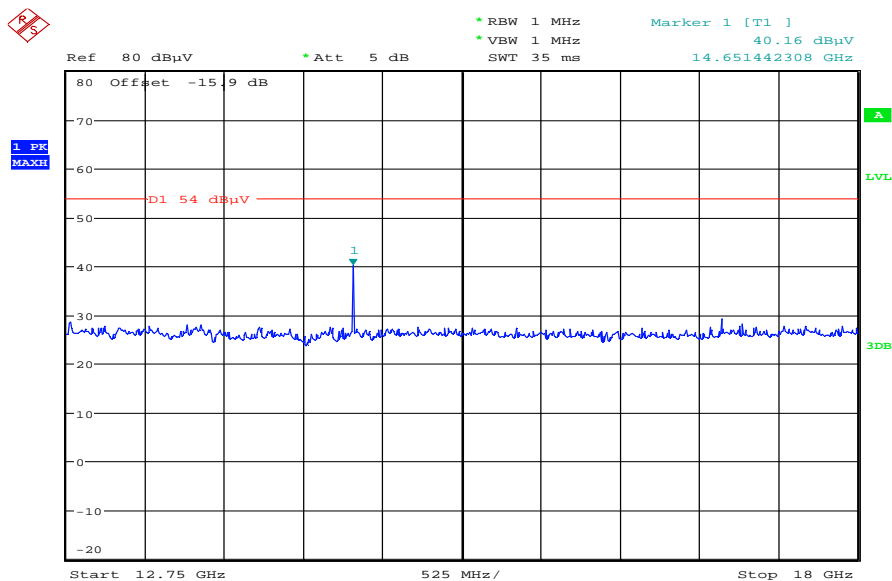

Date: 3.MAR.2011 10:10:30

Plot 5: 18 GHz to 26 GHz, vertical & horizontal polarization

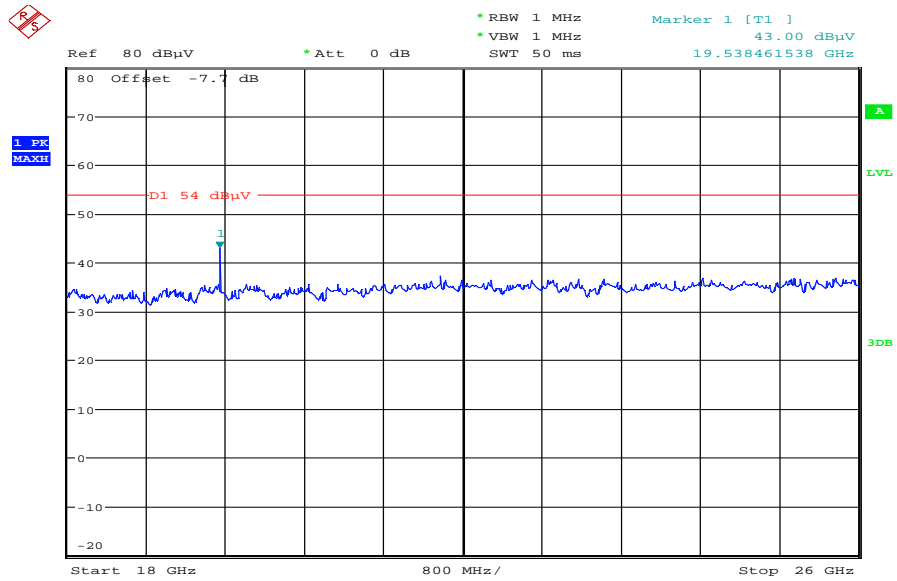

Date: 3.MAR.2011 10:13:59

9.12 TX spurious emissions radiated < 30 MHz

Description:

Measurement of the radiated spurious emissions in transmit mode below 30 MHz. The EUT is set to channel 6. This measurement is representative for all channels and modes. If critical peaks are found channel 1 and channel 11 will be measured too. The measurement is performed with the data rate producing the highest output power. The limits are recalculated to a measurement distance of 3 m with 40 dB/decade according CFR Part 2.

Measurement:

Measurement parameter	
Detector:	Peak / Quasi Peak
Sweep time:	Auto
Video bandwidth:	F < 150 kHz: 200 Hz F > 150 kHz: 9 kHz
Resolution bandwidth:	F < 150 kHz: 1 kHz F > 150 kHz: 100 kHz
Span:	9 kHz to 30 MHz
Trace-Mode:	Max Hold

Limits:

FCC		IC	
CFR Part 15.209(a)		RSS –Gen	
TX Spurious Emissions Radiated < 30 MHz			
Frequency (MHz)	Field Strength (dB μ V/m)	Measurement distance	
0.009 – 0.490	2400/F(kHz)	300	
0.490 – 1.705	24000/F(kHz)	30	
1.705 – 30.0	30	30	

Results:

TX Spurious Emissions Radiated < 30 MHz [dB μ V/m]		
F [MHz]	Detector	Level [dB μ V/m]
No critical peaks found		
Measurement uncertainty	± 3 dB	

Result: The result of the measurement is passed.

Plots: DSSS / b – mode

Plot 1: Middle channel, 9 kHz to 30 MHz

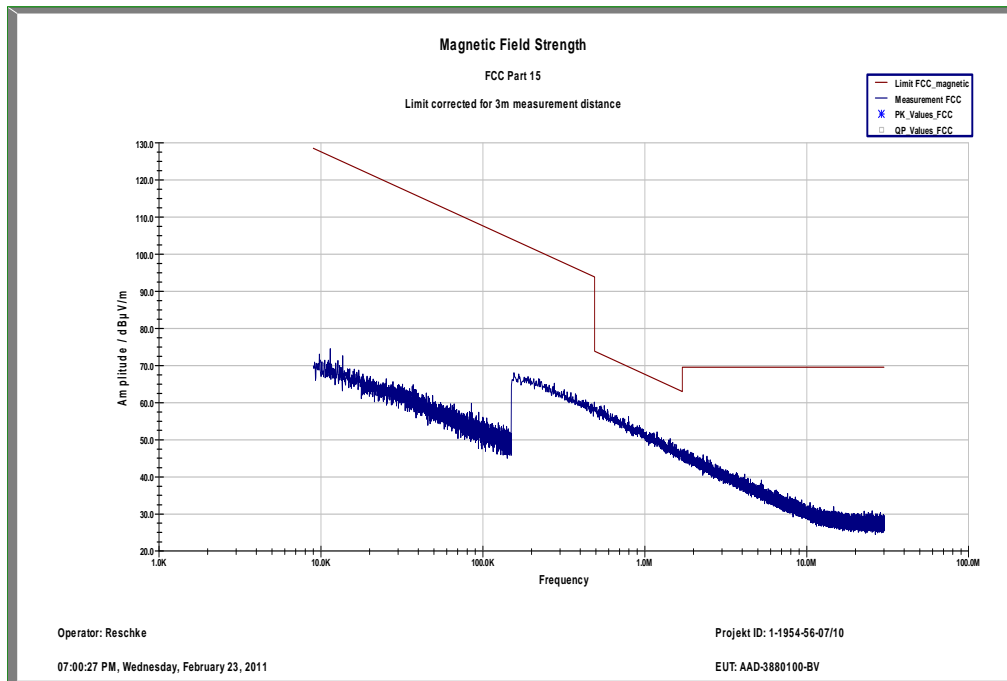

Plots: OFDM / g – mode

Plot 1: Middle channel, 9 kHz to 30 MHz

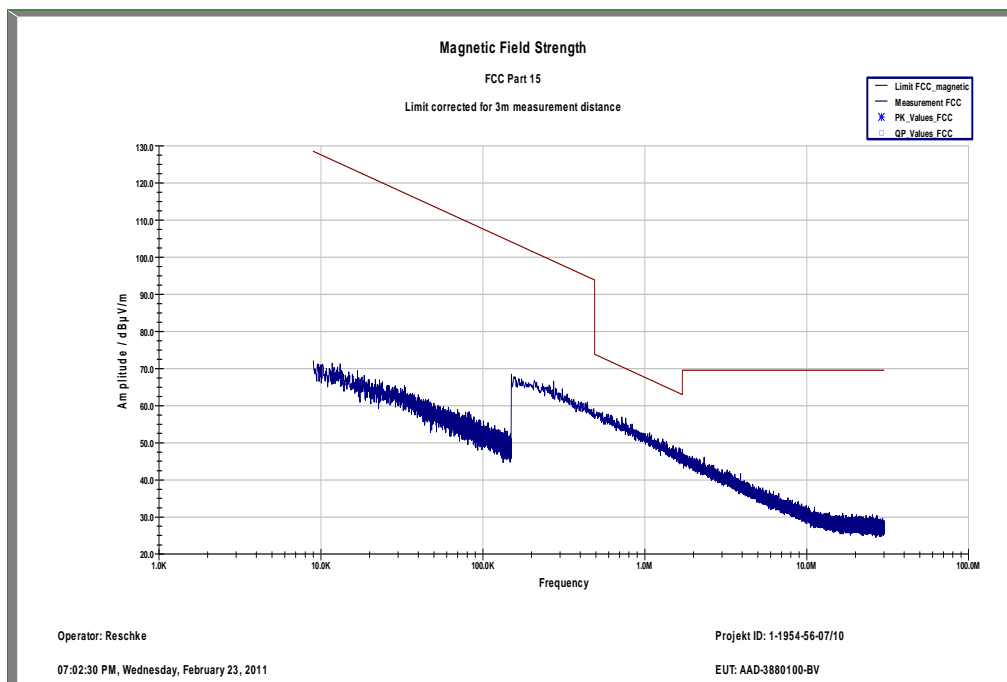

Plots: OFDM / n – mode

Plot 1: Middle channel, 9 kHz to 30 MHz

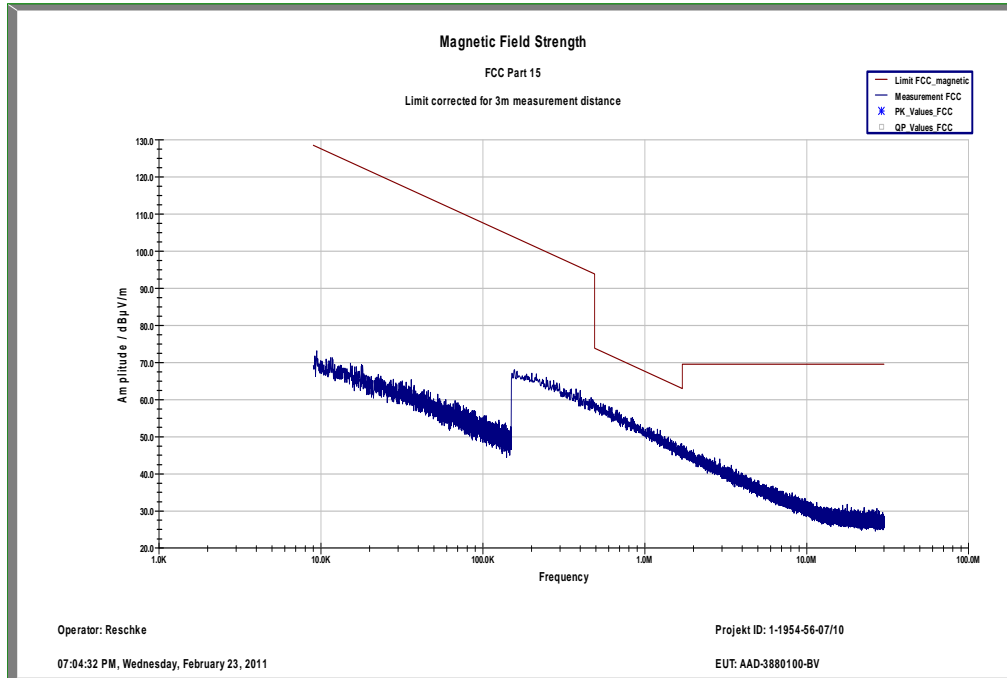

Plots: RX / Idle – mode

Plot 1: 9 kHz to 30 MHz

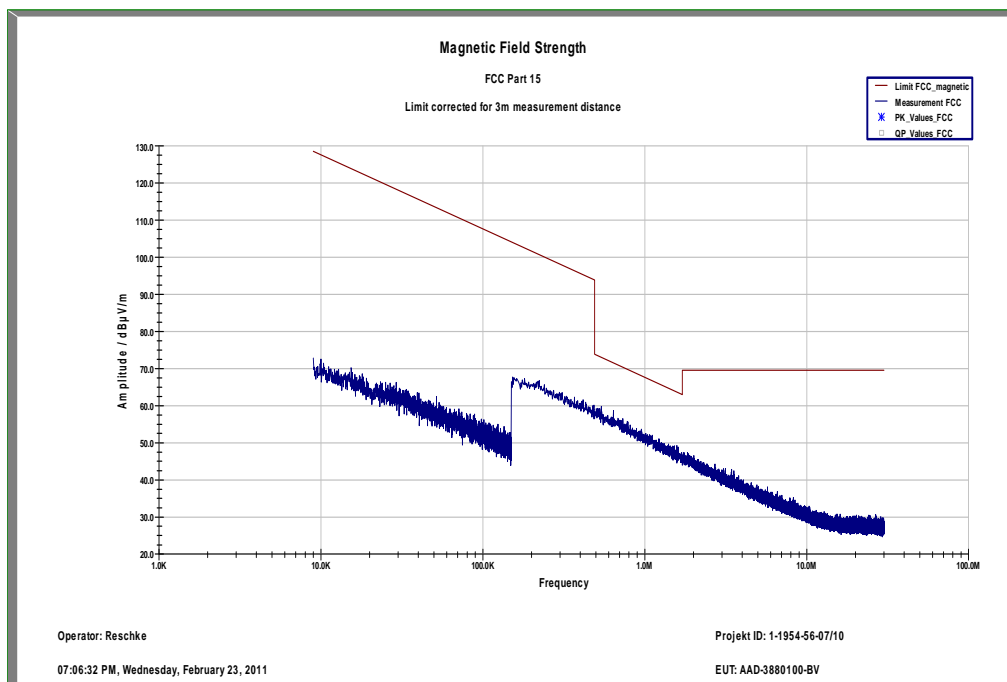

9.13 TX spurious emissions conducted < 30 MHz

Description:

Measurement of the conducted spurious emissions in transmit mode below 30 MHz. The EUT is set to channel 6. This measurement is repeated for DSSS and OFDM modulation. If critical peaks are found channel 1 and channel 11 will be measured too. The measurement is performed with the data rate producing the highest output power. Both power lines, phase and neutral line, are measured. Found peaks are remeasured with average and quasi peak detection to show compliance to the limits.

Measurement:

Measurement parameter	
Detector:	Peak - Quasi Peak / Average
Sweep time:	Auto
Video bandwidth:	F < 150 kHz: 200 Hz F > 150 kHz: 9 kHz
Resolution bandwidth:	F < 150 kHz: 1 kHz F > 150 kHz: 100 kHz
Span:	9 kHz to 30 MHz
Trace-Mode:	Max Hold

Limits:

FCC		IC	
CFR Part 15.107(a)		ICES-003, Issue 4	
TX Spurious Emissions Conducted < 30 MHz			
Frequency (MHz)	Quasi-Peak (dBµV/m)	Average (dBµV/m)	
0.15 – 0.5	66 to 56*	56 to 46*	
0.5 – 5	56	46	
5 – 30.0	60	50	

*Decreases with the logarithm of the frequency

Results:

TX Spurious Emissions Conducted < 30 MHz [dBµV/m]		
F [MHz]	Detector	Level [dBµV/m]
No critical peaks found		
Measurement uncertainty	± 3 dB	

Result: The result of the measurement is passed.

Plots:

Plot 1: DSSS / b – mode, 9 kHz to 30 MHz, phase line

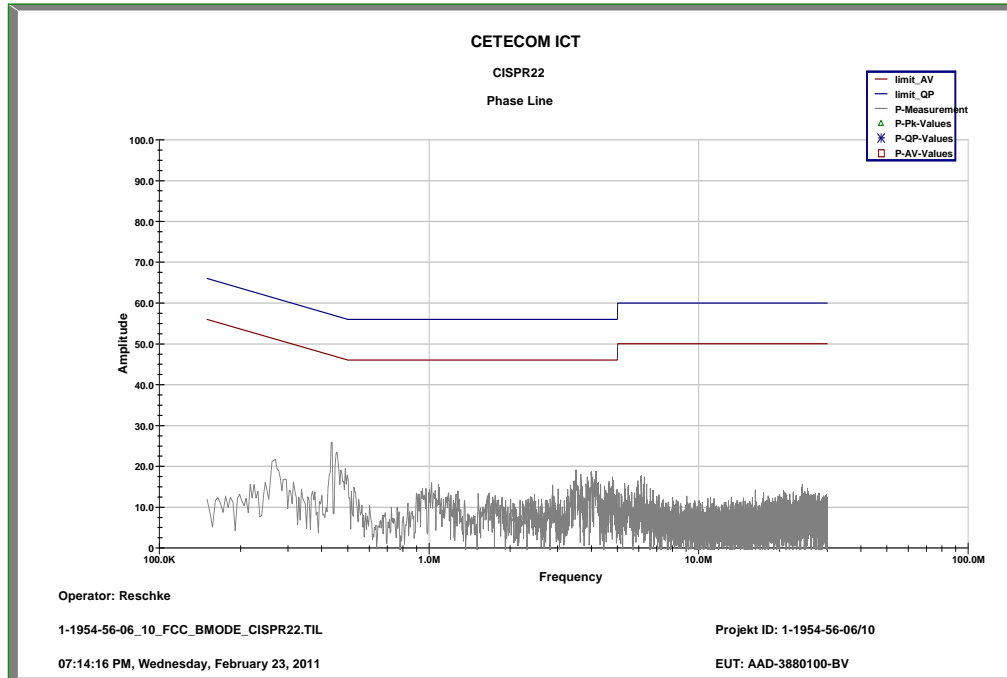

Plot 2: DSSS / b – mode, 9 kHz to 30 MHz, neutral line

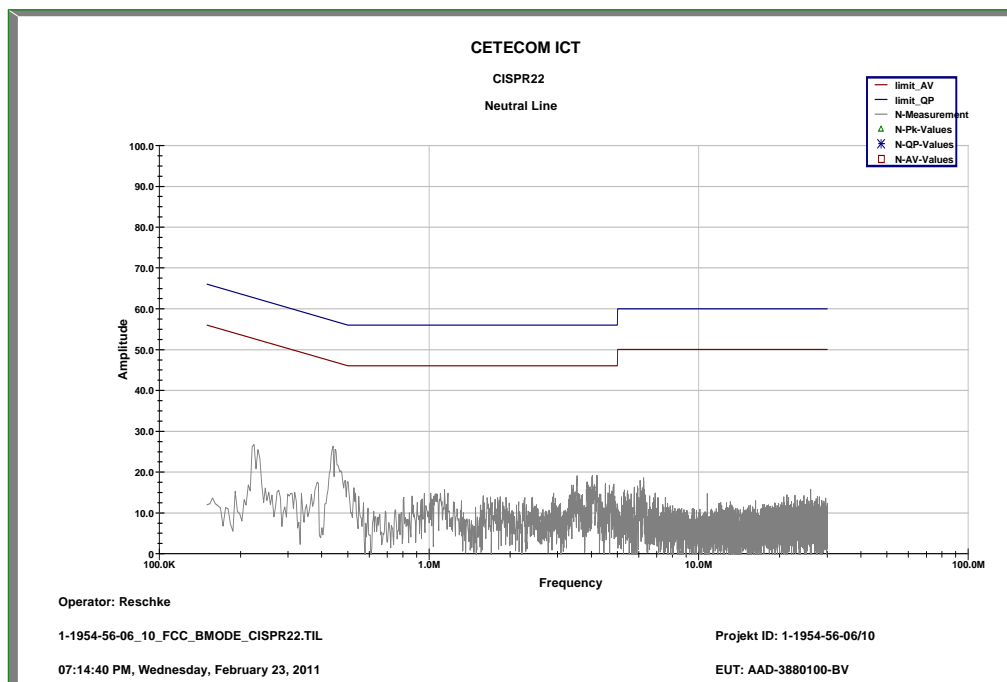

Plot 3: OFDM / g – mode, 9 kHz to 30 MHz, phase line

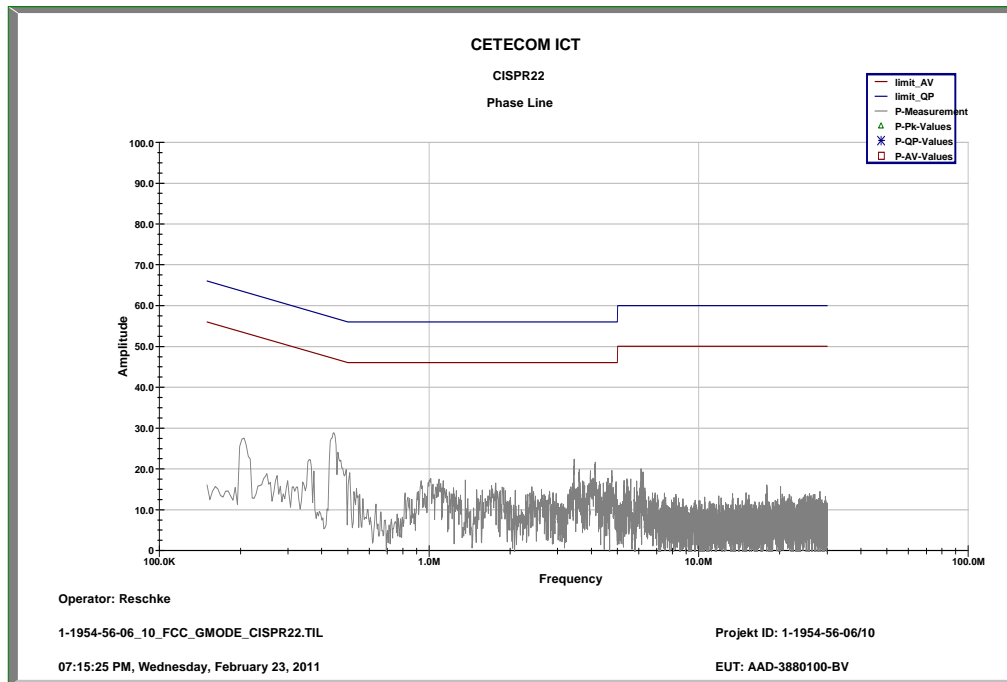

Plot 4: OFDM / g – mode, 9 kHz to 30 MHz, neutral line

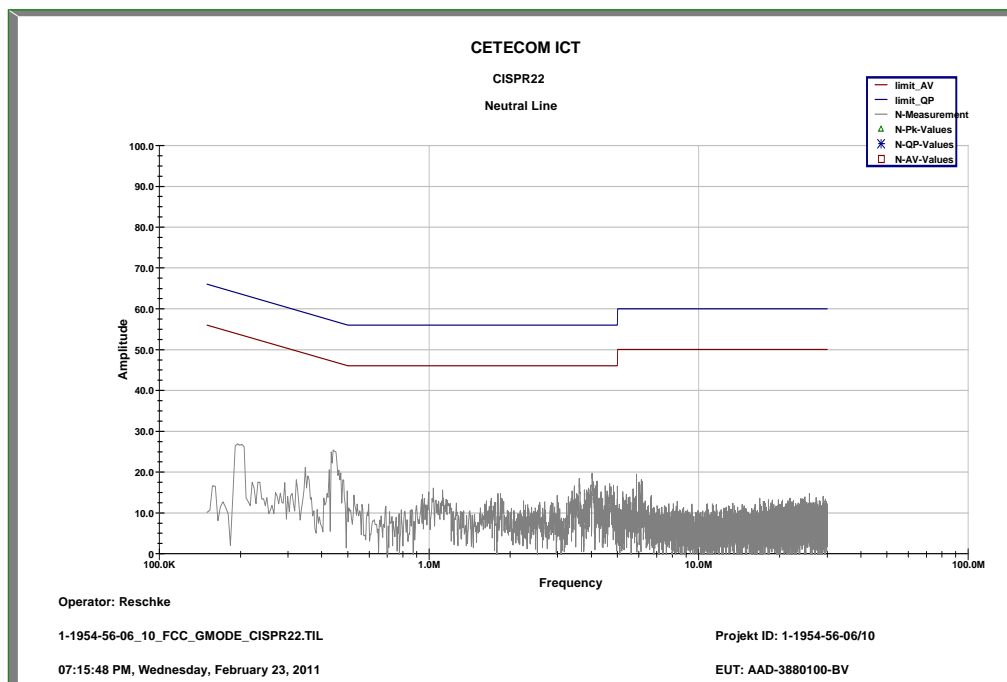

Plot 5: OFDM / n – mode, 9 kHz to 30 MHz, phase line

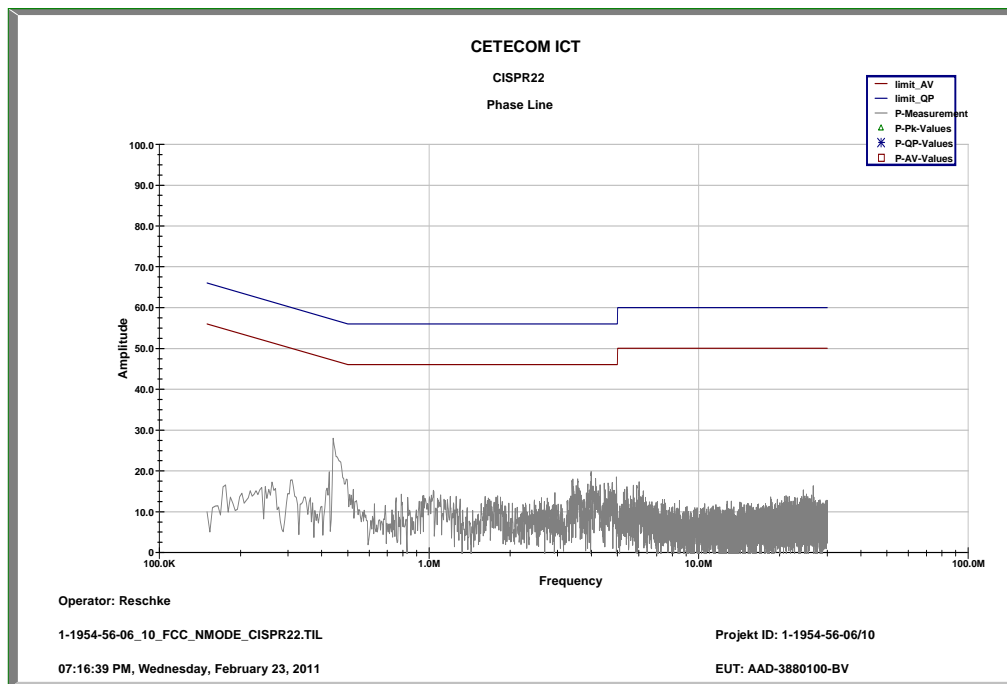

Plot 6: OFDM / n – mode, 9 kHz to 30 MHz, neutral line

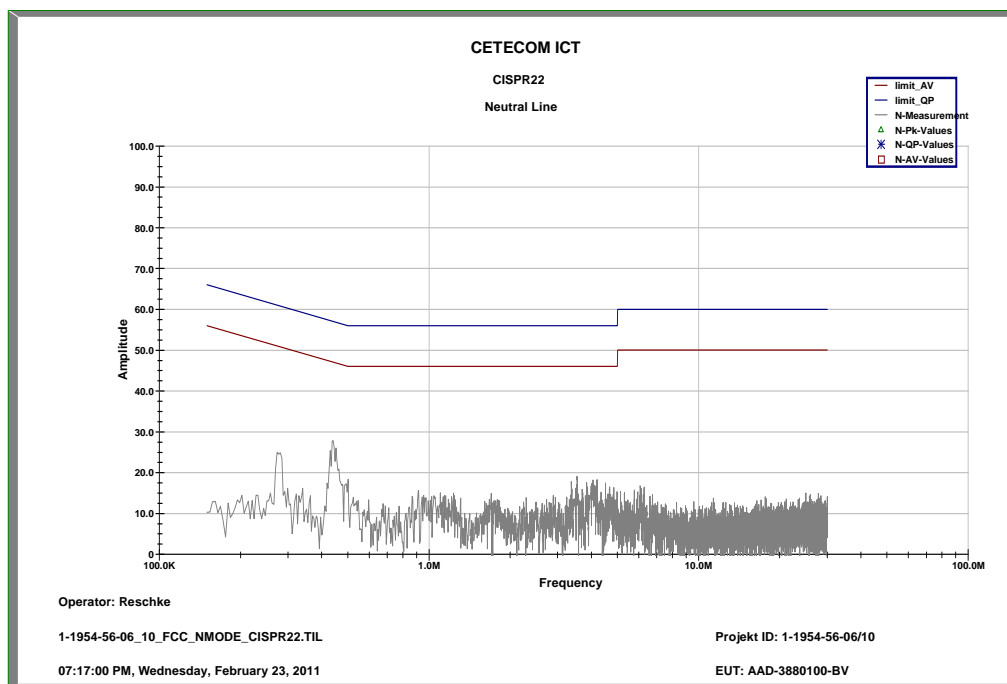

Plot 7: RX / Idle – mode, 9 kHz to 30 MHz, phase line

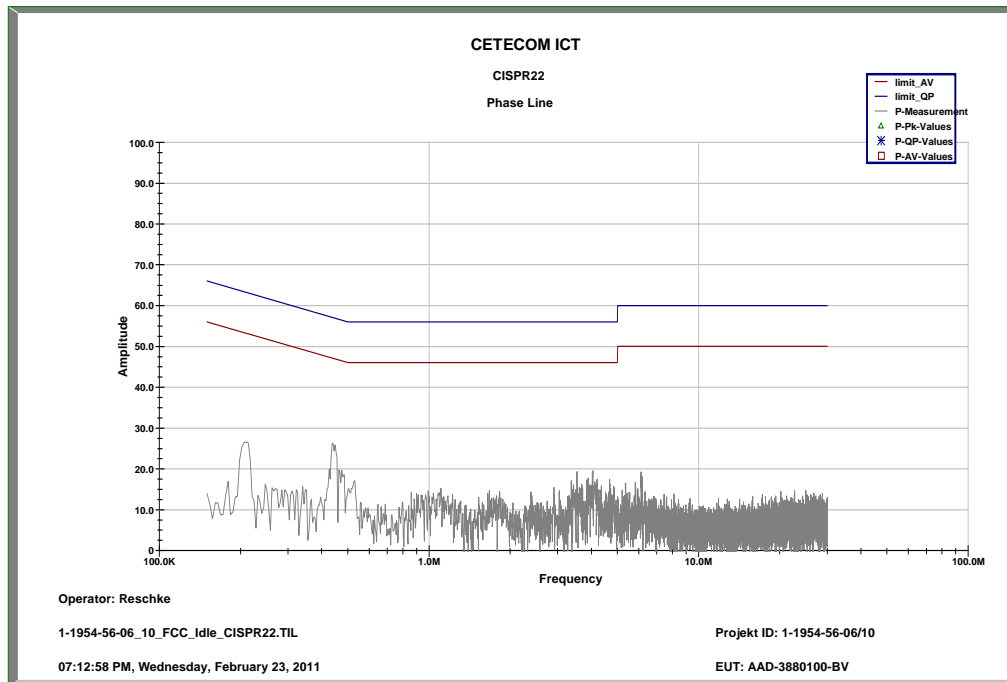

Plot 8: RX / Idle – mode, 9 kHz to 30 MHz, neutral line

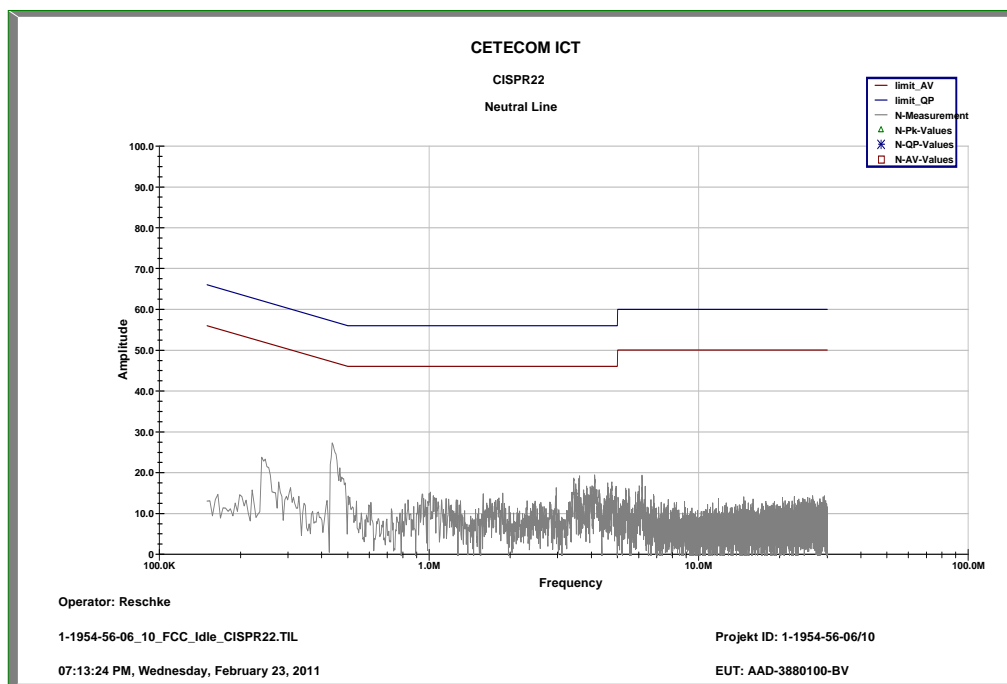

10 Test equipment and ancillaries used for tests

Typically, the calibrations of the test apparatus are commissioned to and performed by an accredited calibration laboratory. The calibration intervals are determined in accordance with the DIN EN ISO/IEC 17025. In addition to the external calibrations, the laboratory executes comparison measurements with other calibrated test systems or effective verifications. Weekly chamber inspections and range calibrations are performed. Where possible, rf-generating and signalling equipment as well as measuring receivers and analyzers are connected to an external high-precision 10 MHz reference (GPS-based or rubidium frequency standard).

In order to simplify the identification of the equipment used at some special tests, some items of test equipment and ancillaries can be provided with an identifier or number in the equipment list below (Labor/Item).

No.	Lab / Item	Equipment	Type	Manufact.	Serial No.	INV. No Cetecom	Kind of Calibration	Last Calibration	Next Calibration
1	n. a.	Spectrum Analyzer 20 Hz - 50 GHz	FSU50	R&S	200012	300003443	ve	01.07.2010	01.07.2012
2	45	Switch-Unit	3488A	HP Meßtechnik	2719A14505	300000368	g		
3	n. a.	software	SPS_PHE 1.4f	Spitzberger & Spieß	B5981; 5D1081;B5979	300000210	ne		
4	n. a.	EMI Test Receiver	ESCI 1166.5950.03	R&S	100083	300003312	k	08.01.2010	08.01.2012
5	n. a.	Amplifier	JS42-00502650-28-5A	MITEQ	1084532	300003379	ev		
6	n. a.	Antenna Tower	Model 2175	ETS-LINDGREN	64762	300003745	izw		
7	n. a.	Positioning Controller	Model 2090	ETS-LINDGREN	64672	300003746	izw		
8	n. a.	Turntable Interface-Box	Model 105637	ETS-LINDGREN	44583	300003747	izw		
9	n. a.	TRILOG Broadband Test-Antenna 30 MHz - 3 GHz	VULB9163	Schwarzbeck	295	300003787	k	01.04.2010	01.04.2012
10	n. a.	Spectrum-Analyzer	FSU26	R&S	200809	300003874	k	08.01.2010	08.01.2012
11	n. a.	Isolating Transformer	RT5A	Grundig	8041	300001626	g		
12	n. a.	PowerAttenuator	8325	Byrd	1530	300001595	ev		
13	n. a.	Double-Ridged Waveguide Horn Antenna 1- 18.0GHz	3115	EMCO	8812-3088	300001032	viKI!	05.03.2009	05.03.2011
14	n. a.	Active Loop Antenna	6502	EMCO	2210	300001015	ne		
15	n. a.	Anechoic chamber	FAC 3/5m	MWB / TDK	87400/02	300000996		23.03.2009	
16	g	Artificial Mains 9 kHz to 30 MHz	ESH3-Z5	R&S	828576/020	300001210	Ve	06.01.2010	06.01.2012
17	n. a.	Relais Matrix	PSU	R&S	890167/024	300001168	ne		
18	n. a.	Three-Way Power Splitter, 50 Ohm	11850C	HP Meßtechnik		300000997	ne		
19	n. a.	Switch / Control Unit	3488A	HP	2605e08770	300001443	ne		
20	n. a.	Amplifier	js42-00502650-28-5a	Parzich GMBH	928979	300003143	ne		
21	n. a.	Band Reject filter	WRCG2400/2483-2375/2505-50/10SS	Wainwright	11	300003351	ev		
22	n. a.	TILE-Software Emission	Quantum Change, Modell TILE-ICS/FULL	EMCO	none	300003451	ne		
23	n. a.	PSA Spectrum Analyzer 3 Hz - 26.5 GHz	E4440A	Agilent Technologies	MY48250080	300003812	k	08.09.2010	08.09.2012
24	n. a.	RF Filter Section 9kHz - 1GHz	N9039A	Agilent Technologies	MY48260003	300003825	viKI!	08.09.2010	08.09.2012
25	n. a.	TRILOG Broadband Test-Antenna 30 MHz - 3 GHz	VULB9163	Schwarzbeck	371	300003854	viKI!	17.12.2008	17.12.2011
26	11b	Microwave System	83017A	HP Meßtechnik	3123A00105	300002268	ev		

		Amplifier, 0.5-26.5 GHz; 25 dB gain							
27	A026	Std. Gain Horn Antenna 12.4 to 18.0 GHz	639	Narda		300000787	ne		
28	A029	Std. Gain Horn Antenna 18.0 to 26.5 GHz	638	Narda		300002442	ne		
29	n. a.	Switch / Control Unit	3488A	HP Meßtechnik		300001691	ne		
30	n. a.	Signal Analyzer 20Hz-26,5GHz-150 to + 30 DBM	FSIQ26	R&S	835540/018	300002681-0005	k	07.01.2010	07.01.2012

Agenda: Kind of Calibration

k calibration / calibrated
 ne not required (k, ev, izw, zw not required)
 ev periodic self verification
 Ve long-term stability recognized
 vlk! Attention: extended calibration interval
 NK! Attention: not calibrated

EK limited calibration
 zw cyclical maintenance (external cyclical maintenance)
 izw internal cyclical maintenance
 g blocked for accredited testing
 *) next calibration ordered / currently in progress