



## TEST REPORT

Test report no.: 1-2977-06-08/11



### Testing laboratory

**CETECOM ICT Services GmbH**  
Untertuerkheimer Straße 6 – 10  
66117 Saarbruecken / Germany  
Phone: + 49 681 5 98 - 0  
Fax: + 49 681 5 98 - 9075  
Internet: <http://www.cetecom.com>  
e-mail: [ict@cetecom.com](mailto:ict@cetecom.com)

#### Accredited test laboratory:

The test laboratory (area of testing) is accredited according to DIN EN ISO/IEC 17025  
DAR registration number: DGA-PL-176/94-D1

Area of Testing: Radio/Satellite Communications

### Applicant

**Sony Ericsson Mobile Communications AB**  
Nya Vattentornet  
22188 Lund / Sweden  
Phone: +46 46 19 30 00  
Fax: +46 46 19 32 95  
Contact: Johan Wedin  
e-mail: [johan.wedin@sonyericsson.com](mailto:johan.wedin@sonyericsson.com)  
Phone: +46 70 71 95 73 6

### Manufacturer

**Sony Ericsson Mobile Communications AB**  
Nya Vattentornet  
22188 Lund / Sweden

### Test standard/s

47 CFR Part 15	Title 47 of the Code of Federal Regulations; Chapter I Part 15 - Radio frequency devices
RSS - 210 Issue 8	Spectrum Management and Telecommunications - Radio Standards Specification Low-power Licence-exempt Radiocommunication Devices (All Frequency Bands): Category I Equipment

For further applied test standards please refer to section 3 of this test report.

### Test item

Kind of test item:	Mobile Phone GSM/EDGE 850,900,1800,1900; UMTS FDD1, FDD8; BT2.1+EDR; WLAN; A-GPS; FM Rx
Model name:	AAAD-3880088-BV
FCC ID:	PY7A3880088
IC:	4170B-A3880088
Frequency [MHz]:	ISM – band 2400 MHz to 2483.5 MHz (lowest channel 2412 MHz; highest channel 2462 MHz)
Power supply:	3.6V DC by battery BST-41 and charger EP800 / power supply
Temperature range:	-20 °C to +55 °C

### Test performed:

2011-02-15 Marco Bertolino

### Test report authorised:

2011-02-15 Stefan Bös

<b>1 Table of contents</b>	
1	Table of contents .....2
2	General information .....3
2.1	Notes.....3
2.2	Application details.....3
3	Test standard/s .....3
4	Test environment.....3
5	Test item .....4
6	Test laboratories sub-contracted .....4
7	Summary of measurement results .....5
8	RF measurement testing.....6
8.1	Description of test setup .....6
8.1.1	Radiated measurements.....6
8.1.2	Conducted measurements.....7
8.2	Additional comments .....7
8.3	RSP100 test report cover sheet / performance test data .....8
9	Measurement results.....9
9.1	Maximum output power (conducted) .....9
9.2	Antenna gain .....20
9.3	Power spectral density .....23
9.4	Spectrum bandwidth of a FHSS system – 6 dB bandwidth .....29
9.5	Spectrum bandwidth of a FHSS system – 20 dB bandwidth .....35
9.6	Maximum output power .....41
9.7	Band edge compliance conducted .....48
9.8	Band edge compliance radiated .....52
9.9	TX spurious emissions conducted.....59
9.10	TX spurious emissions radiated.....77
9.11	RX spurious emissions radiated .....116
9.12	TX spurious emissions radiated < 30 MHz .....121
9.13	TX spurious emissions conducted < 30 MHz.....127
10	Test equipment and ancillaries used for tests .....132
Annex A	Photographs of the test setup .....134
Annex B	External photographs of the EUT .....140
Annex C	Internal photographs of the EUT .....147
Annex D	Document history .....163
Annex E	Further information.....163

## 2 General information

### 2.1 Notes

The test results of this test report relate exclusively to the test item specified in this test report. CETECOM ICT Services GmbH does not assume responsibility for any conclusions and generalisations drawn from the test results with regard to other specimens or samples of the type of the equipment represented by the test item. The test report may only be reproduced or published in full. Reproduction or publication of extracts from the report requires the prior written approval of CETECOM ICT Services GmbH.

### 2.2 Application details

Date of receipt of order:	2011-01-21
Date of receipt of test item:	2011-01-28
Start of test:	2011-02-10
End of test:	2011-02-12
Person(s) present during the test:	-/-

## 3 Test standard/s

Test standard	Version	Test standard description
47 CFR Part 15	2009-10	Title 47 of the Code of Federal Regulations; Chapter I Part 15 - Radio frequency devices
RSS - 210 Issue 8	2010-12	Spectrum Management and Telecommunications - Radio Standards Specification Low-power Licence-exempt Radiocommunication Devices (All Frequency Bands): Category I Equipment

## 4 Test environment

Temperature:	$T_{nom}$	+20 °C during room temperature tests
	$T_{max}$	+55 °C during high temperature test
	$T_{min}$	-20 °C during low temperature test
Relative humidity content:		55 %
Air pressure:		not relevant for this kind of testing
Power supply:	$V_{nom}$	3.6 V DC by battery BST-41 and charger EP800 / power supply
	$V_{max}$	4.0 V
	$V_{min}$	3.2 V

## 5 Test item

Kind of test item	:	Mobile Phone GSM/EDGE 850,900,1800,1900; UMTS FDD1, FDD8; BT2.1+EDR; WLAN; A-GPS; FM Rx
Type identification	:	AAD-3880088-BV
S/N serial number	:	Radiated units: CB5A1CGLBX, CB5A1CGJZQ Conducted units: CB5A1CGJX7, CB5A1CGLDM
HW hardware status	:	AP2
SW software status	:	3.0.A.1.79 ATP
Frequency band [MHz]	:	ISM – band 2400 MHz to 2483.5 MHz (lowest channel 2412 MHz; highest channel 2462 MHz)
Type of modulation	:	DSSS & OFDM technology with BPSK, QPSK, 16- & 64 QAM.
Number of channels	:	11
Antenna	:	Integrated antenna → for more information, please take a look at the annex – internal photos of the EUT.
Power supply	:	3.6 V DC by battery BST-41 and charger EP800 / power supply
Temperature range	:	-20°C to +55 °C

## 6 Test laboratories sub-contracted

None

## 7 Summary of measurement results

- No deviations from the technical specifications were ascertained
- There were deviations from the technical specifications ascertained

TC Identifier	Description	Verdict	Date	Remark
RF-Testing	CFR Part 15 RSS 210, Issue 8, Annex 8	Passed	2011-02-15	-/-

Test specification clause	Test case	Temperature conditions	Power source voltages	Mode	Pass	Fail	NA	NP	Results (max.)
§15.247(b)(4) RSS 210 / A8.4(2)	Antenna gain	Nominal	Nominal	DSSS	<input checked="" type="checkbox"/>	<input type="checkbox"/>	<input type="checkbox"/>	<input type="checkbox"/>	complies
§15.247(e) RSS 210 / A8.2(b)	Power spectral density	Nominal	Nominal	DSSS OFDM	<input checked="" type="checkbox"/> <input checked="" type="checkbox"/>	<input type="checkbox"/> <input type="checkbox"/>	<input type="checkbox"/> <input type="checkbox"/>	<input type="checkbox"/> <input type="checkbox"/>	complies
§15.247(a)(2) RSS 210 / A8.2(a)	Spectrum bandwidth of a FHSS system 6dB bandwidth	Nominal	Nominal	DSSS OFDM	<input checked="" type="checkbox"/> <input checked="" type="checkbox"/>	<input type="checkbox"/> <input type="checkbox"/>	<input type="checkbox"/> <input type="checkbox"/>	<input type="checkbox"/> <input type="checkbox"/>	complies
§15.247(a)(2) RSS 210 / A8.2(a)	Spectrum bandwidth of a FHSS system 20dB bandwidth	Nominal	Nominal	DSSS OFDM	<input checked="" type="checkbox"/> <input checked="" type="checkbox"/>	<input type="checkbox"/> <input type="checkbox"/>	<input type="checkbox"/> <input type="checkbox"/>	<input type="checkbox"/> <input type="checkbox"/>	complies
§15.247(b)(3) RSS-210 / A8.4(4)	Maximum output power	Nominal	Nominal	DSSS OFDM	<input checked="" type="checkbox"/> <input checked="" type="checkbox"/>	<input type="checkbox"/> <input type="checkbox"/>	<input type="checkbox"/> <input type="checkbox"/>	<input type="checkbox"/> <input type="checkbox"/>	complies
§15.247(d) RSS-210 / A8.5	Band edge compliance conducted	Nominal	Nominal	DSSS OFDM	<input checked="" type="checkbox"/> <input checked="" type="checkbox"/>	<input type="checkbox"/> <input type="checkbox"/>	<input type="checkbox"/> <input type="checkbox"/>	<input type="checkbox"/> <input type="checkbox"/>	complies
§15.205 RSS-210 / A8.5	Band edge compliance radiated	Nominal	Nominal	DSSS OFDM	<input checked="" type="checkbox"/> <input checked="" type="checkbox"/>	<input type="checkbox"/> <input type="checkbox"/>	<input type="checkbox"/> <input type="checkbox"/>	<input type="checkbox"/> <input type="checkbox"/>	complies
§15.247(d) RSS-210 / A8.5	TX spurious emissions conducted	Nominal	Nominal	DSSS OFDM	<input checked="" type="checkbox"/> <input checked="" type="checkbox"/>	<input type="checkbox"/> <input type="checkbox"/>	<input type="checkbox"/> <input type="checkbox"/>	<input type="checkbox"/> <input type="checkbox"/>	complies
§15.247(d) RSS-210 / A8.5	TX spurious emissions radiated	Nominal	Nominal	DSSS OFDM	<input checked="" type="checkbox"/> <input checked="" type="checkbox"/>	<input type="checkbox"/> <input type="checkbox"/>	<input type="checkbox"/> <input type="checkbox"/>	<input type="checkbox"/> <input type="checkbox"/>	complies
§15.109 RSS-Gen.	RX spurious emissions radiated	Nominal	Nominal	-/-	<input checked="" type="checkbox"/>	<input type="checkbox"/>	<input type="checkbox"/>	<input type="checkbox"/>	complies
§15.209(a) RSS-Gen	TX spurious emissions radiated < 30 MHz	Nominal	Nominal	DSSS OFDM	<input checked="" type="checkbox"/> <input checked="" type="checkbox"/>	<input type="checkbox"/> <input type="checkbox"/>	<input type="checkbox"/> <input type="checkbox"/>	<input type="checkbox"/> <input type="checkbox"/>	complies
§15.107(a)	Conducted emissions < 30 MHz	Nominal	Nominal	DSSS OFDM	<input checked="" type="checkbox"/> <input checked="" type="checkbox"/>	<input type="checkbox"/> <input type="checkbox"/>	<input type="checkbox"/> <input type="checkbox"/>	<input type="checkbox"/> <input type="checkbox"/>	complies

**Note:** NA = Not Applicable; NP = Not Performed

## 8 RF measurement testing

### 8.1 Description of test setup

#### 8.1.1 Radiated measurements

The radiated measurements are performed in vertical and horizontal plane in the frequency range from 9 kHz to 25 GHz in semi-anechoic chambers. The EUT is positioned on a non-conductive support with a height of 0.80 m above a conductive ground plane that covers the whole chamber. The receiving antennas are confirmed with specifications ANSI C63.2-1996 clause 15 and ANSI C63.4-2009 clause 4.1.5. These antennas can be moved over the height range between 1.0 m and 4.0 m in order to search for maximum field strength emitted from EUT. The measurement distances between EUT and receiving antennas are indicated in the test setups for the various frequency ranges. For each measurement, the EUT is rotated in all three axes until the maximum field strength is received. The wanted and unwanted emissions are received by spectrum analysers where the detector modes and resolution bandwidths over various frequency ranges are set according to requirement ANSI C63-4-2009 clause 4.2.

Antennas are confirmed with ANSI C63.2-1996 item 15.

Semi anechoic chamber

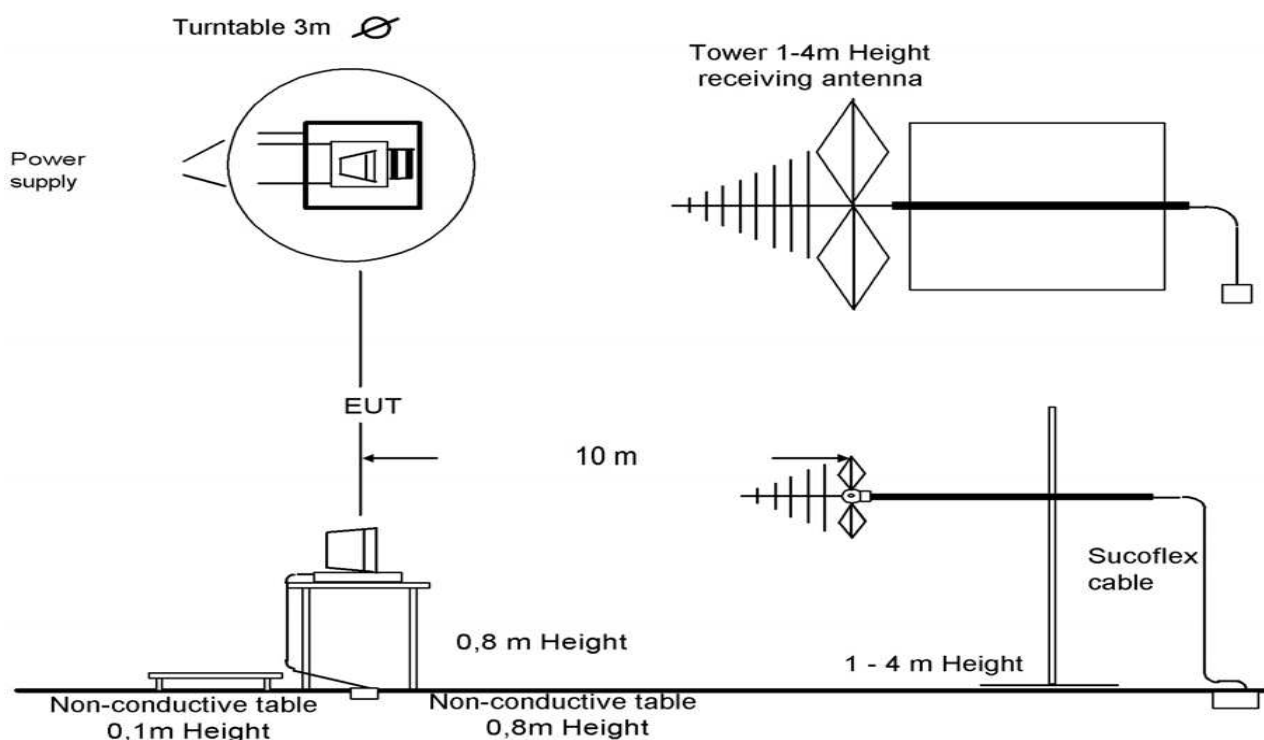

Picture 1: Diagram radiated measurements

9 kHz - 30 MHz:	active loop antenna
30 MHz – 1 GHz:	tri-log antenna
> 1 GHz:	horn antenna

The EUT is powered by an external power supply with nominal voltage. The signalling is performed from outside the chamber with a signalling unit (CMU200 or other) by air link using signalling antenna.

### 8.1.2 Conducted measurements

The EUT's RF signal is coupled out by the antenna connector which is supplied by the manufacturer. The signal is first 10dB attenuated before it is power divided (~6dB loss per branch). One of the signal paths is connected to the communication base Station (CMU200 or other), the other one is connected to the spectrum analyzer. The specific losses for both signal paths are first checked within a calibration. The measurement readings on the signalling unit/spectrum analyzer are corrected by the specific test set-up loss. The attenuator, power divider, signalling unit and the spectrum analyzer are impedance matched on 50 Ohm.

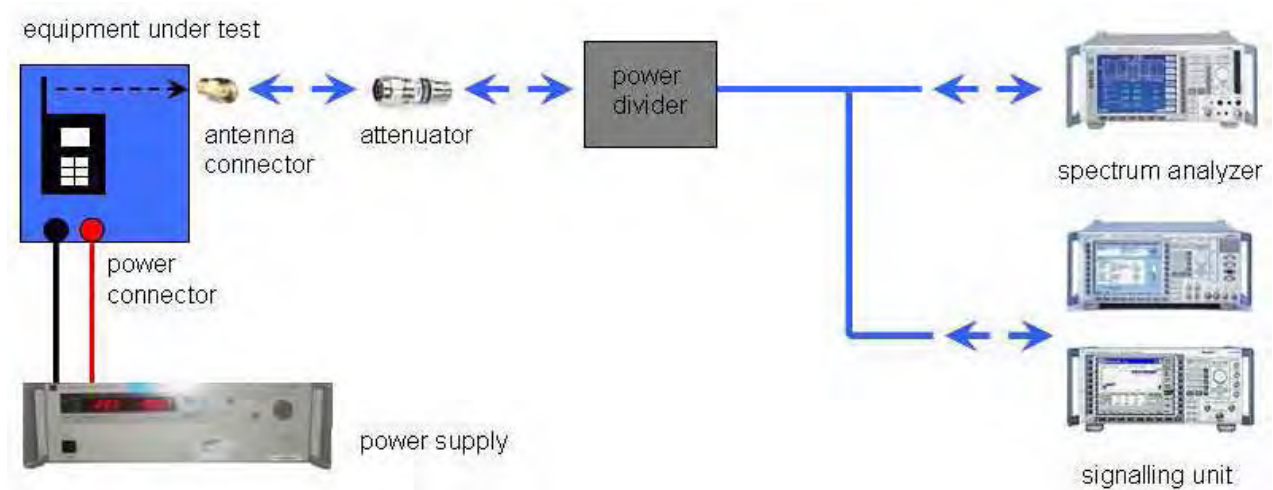

Picture 2: Diagram conducted measurements

### 8.2 Additional comments

Reference documents: WiFi and BT commands \_FCC.txt

Special test descriptions: None

Configuration descriptions: None

- Test mode:
- No test mode available.  
lperf was used to ping another device with the largest support packet size
  - Special software is used.  
EUT is transmitting pseudo random data by itself

### 8.3 RSP100 test report cover sheet / performance test data

Test report number	:	1-2977-06-08/11
Equipment model number	:	AAD-3880088-BV
Certification number	:	4170B-A3880088
Manufacturer (complete address)	:	Sony Ericsson Mobile Communications AB Nya Vattentorget 22188 Lund / Sweden
Tested to radio standards specification no.	:	RSS 210, Issue 8, Annex 8
Open area test site IC No.	:	IC 3462C-1
Frequency range	:	ISM – band 2400 MHz to 2483.5 MHz (lowest channel 2412 MHz; highest channel 2462 MHz)
RF-power [W] (max.)	:	<u>Maximum conducted values:</u> 133.05 mW (DSSS / b - mode) 284.45 mW (OFDM / g - mode) 236.05 mW (OFDM / n - mode)  <u>Maximum radiated values:</u> 94.84 mW (DSSS / b - mode) 188.80 mW (OFDM / g - mode) 156.68 mW (OFDM / n - mode)
Occupied bandwidth (99%-BW) [kHz]	:	(DSSS / b - mode): 13.94 MHz (OFDM / g - mode): 18.17 MHz (OFDM / n - mode): 18.75 MHz
Type of modulation	:	DSSS & OFDM technology with BPSK, QPSK, 16- and 64-QAM modulation.
Emission designator (TRC-43)	:	13M9G1D (DSSS / b - mode) 18M2G7D (OFDM / g - mode) 18M8G7D (OFDM / n - mode)
Antenna information	:	Integrated antenna → for more information, please take a look at the annex – internal photos of the EUT.
Transmitter spurious (worst case) [dB $\mu$ V/m @ 3m]:		47.5 dB $\mu$ V/m @ 2.39 GHz (RBW / VBW - 1MHz / 10Hz)
Receiver spurious (worst case) [dB $\mu$ V/m @ 3m]:		43.0 dB $\mu$ V/m @ 12 GHz (noise floor - RBW & VBW 1MHz)

#### ATTESTATION:

#### DECLARATION OF COMPLIANCE:

I attest that the testing was performed or supervised by me; that the test measurements were made in accordance with the above-mentioned Industry Canada standard(s); and that the equipment identified in this application has been subjected to all the applicable test conditions specified in the Industry Canada standards and all of the requirements of the standard have been met.

#### Laboratory manager:

2011-02-15

Marco Bertolino

Date

Name

  
Signature



## 9 Measurement results

### 9.1 Maximum output power (conducted)

#### Description:

Measurement of the maximum output power conducted. This measurement is performed only at the middle channel in both modes and all data rates to determine the data rate per mode which results in the highest output power. This mode will be selected for all further measurements.

#### Measurement:

Measurement parameter	
Detector:	Peak
Sweep time:	1s
Video bandwidth:	30 MHz
Resolution bandwidth:	50 MHz
Span:	100 MHz
Trace-Mode:	Max Hold

#### Results:

DSSS / b – mode Data Rate [MBit/s]	Maximum Output Power Conducted [dBm]			
	1	2	5.5	11
Ch 6 - 2437 MHz	21.06	20.96	21.07	21.02
Measurement uncertainty	± 0.5 dB			

OFDM / g – mode Data Rate [MBit/s]	Maximum Output Power Conducted [dBm]							
	6	9	12	18	24	36	48	54
Ch 6 - 2437 MHz	24.45	24.54	24.42	24.38	24.48	24.45	24.16	24.23
Measurement uncertainty	± 0.5 dB							

OFDM / n – mode Data Rate [MBit/s]	Maximum Output Power Conducted [dBm]							
	MCS0	MCS1	MCS2	MCS3	MCS4	MCS5	MCS6	MCS7
Ch 6 - 2437 MHz	23.73	23.57	23.51	23.42	23.33	23.46	23.46	23.58
Measurement uncertainty	± 0.5 dB							

**Result:** Selected data rate for all measurements:

DSSS / b – mode:

5.5 MBit/s

OFDM / g – mode:

9 MBit/s

OFDM / n – mode:

MCS0

**Plots: DSSS / b – mode**

**Plot 1: TX mode, middle channel, 1 MBit/s**

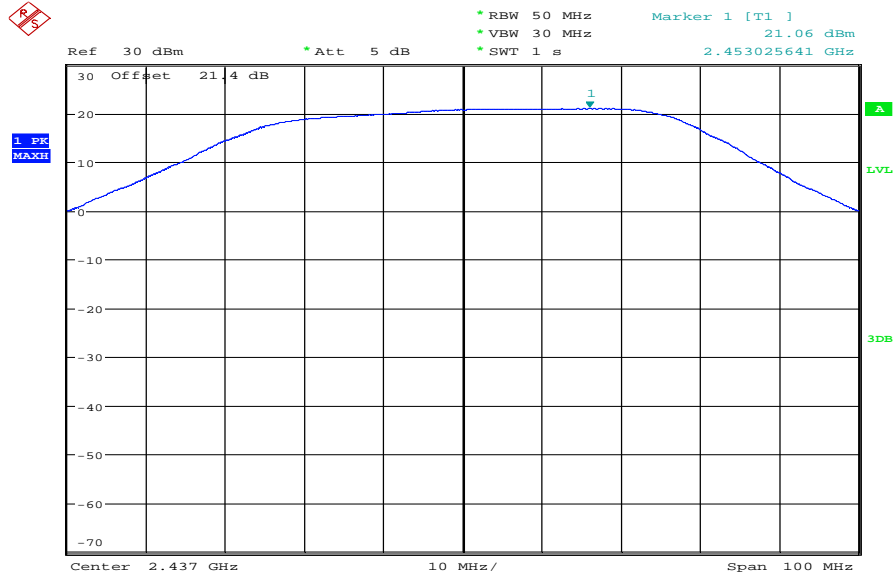

Date: 11.FEB.2011 10:48:02

**Plot 2: TX mode, middle channel, 2 MBit/s**

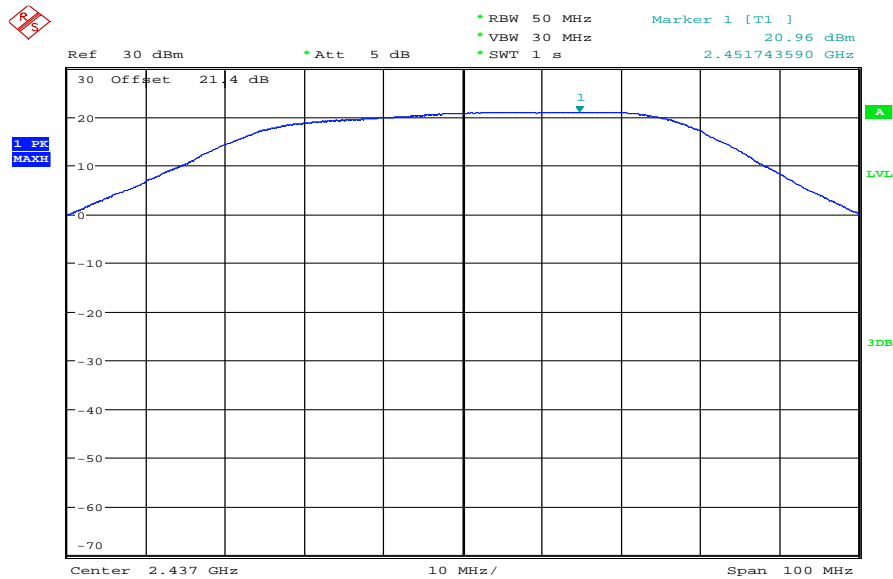

Date: 11.FEB.2011 10:48:51

Plot 3: TX mode, middle channel, 5.5 MBit/s

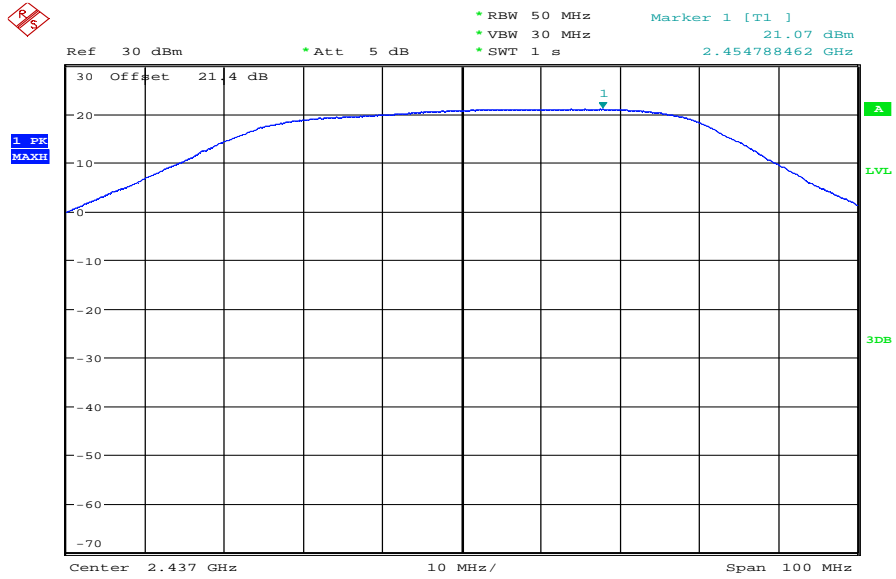

Date: 11.FEB.2011 10:50:13

Plot 4: TX mode, middle channel, 11 MBit/s

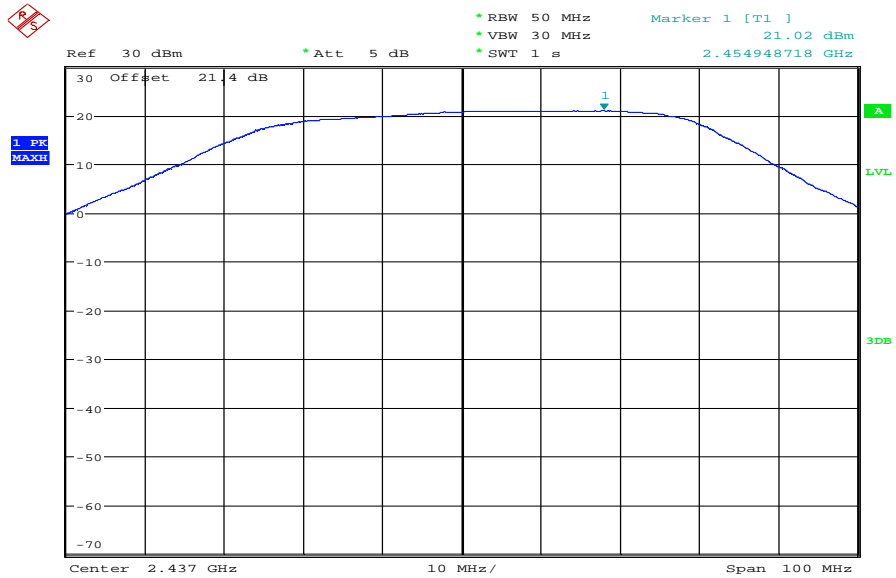

Date: 11.FEB.2011 10:51:23

**Plots: OFDM / g – mode**

**Plot 1: TX mode, middle channel, 6 MBit/s**

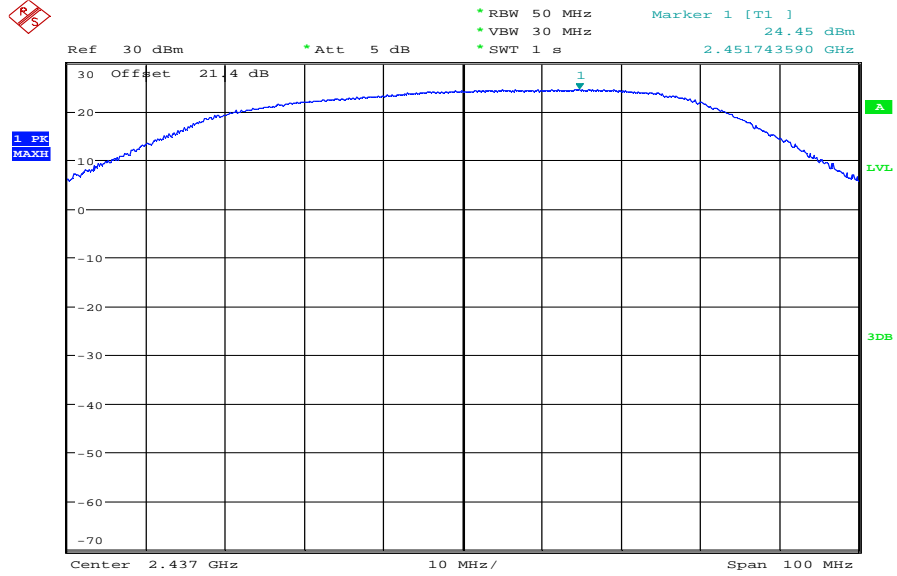

Date: 11.FEB.2011 11:21:39

**Plot 2: TX mode, middle channel, 9 MBit/s**

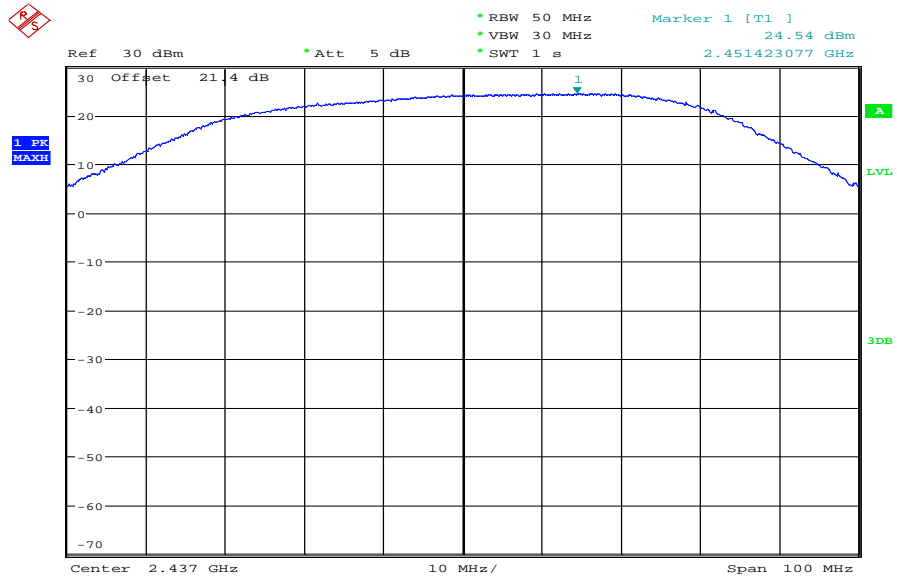

Date: 11.FEB.2011 11:22:35

Plot 3: TX mode, middle channel, 12 MBit/s

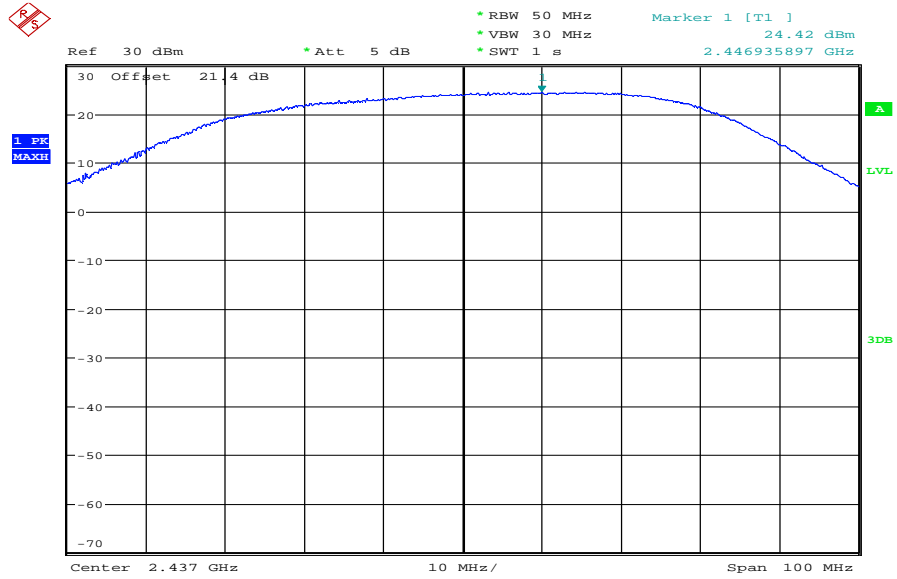

Date: 11.FEB.2011 11:23:47

Plot 4: TX mode, middle channel, 18 MBit/s

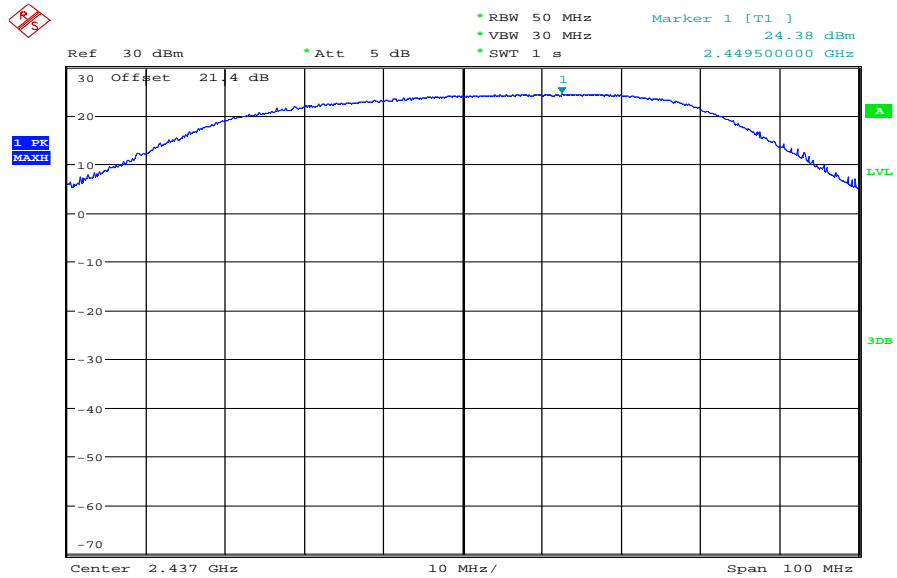

Date: 11.FEB.2011 11:24:47

Plot 5: TX mode, middle channel, 24 MBit/s

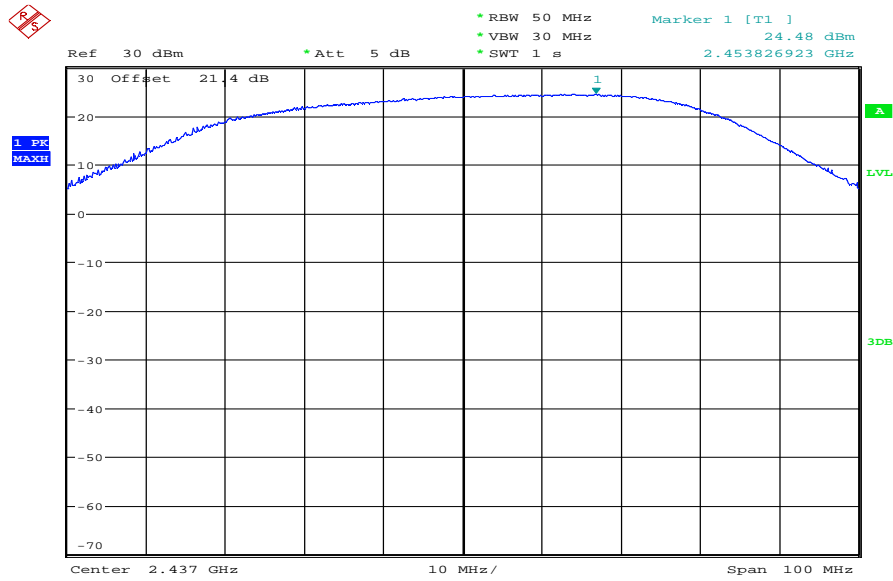

Date: 11.FEB.2011 11:26:03

Plot 6: TX mode, middle channel, 36 MBit/s

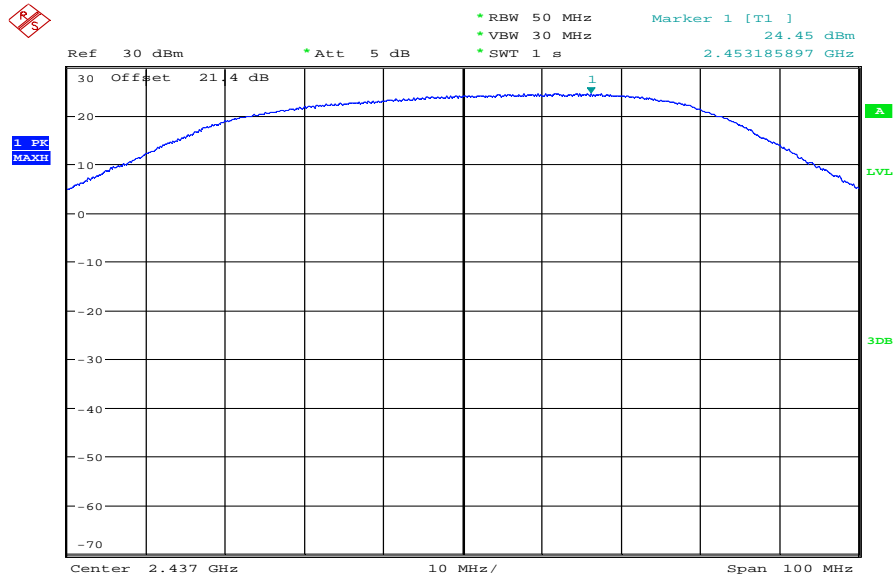

Date: 11.FEB.2011 11:27:10

Plot 7: TX mode, middle channel, 48 MBit/s

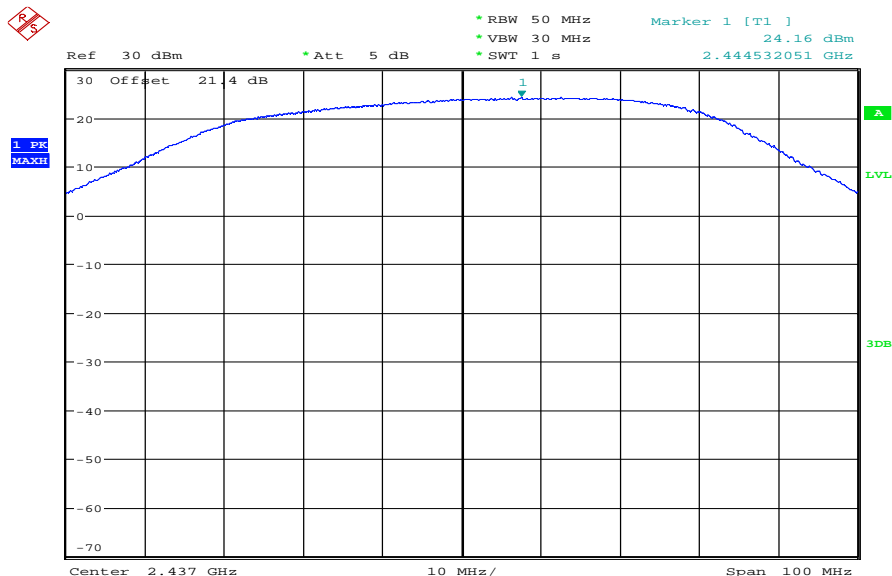

Date: 11.FEB.2011 11:28:24

Plot 8: TX mode, middle channel, 54 MBit/s

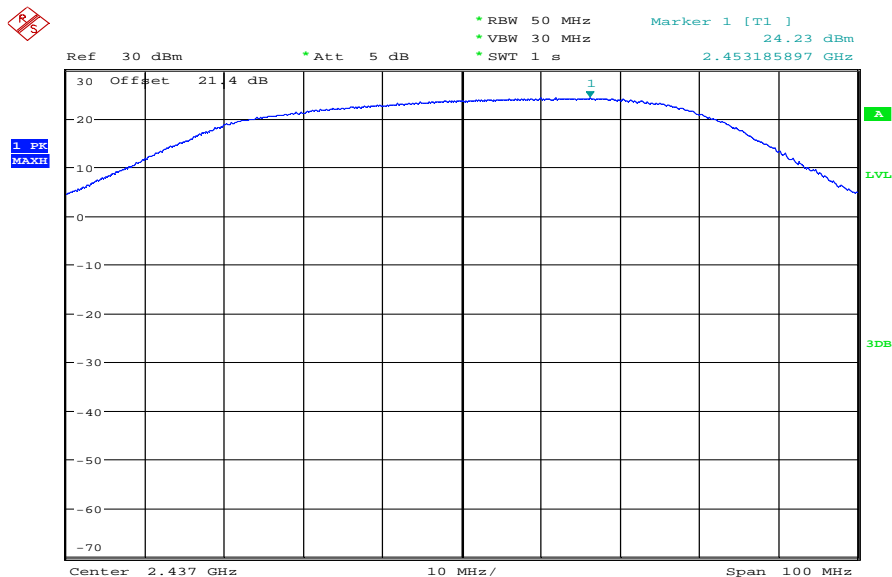

Date: 11.FEB.2011 11:29:24

**Plots: OFDM / n – mode**

**Plot 1: TX mode, middle channel, MCS0**

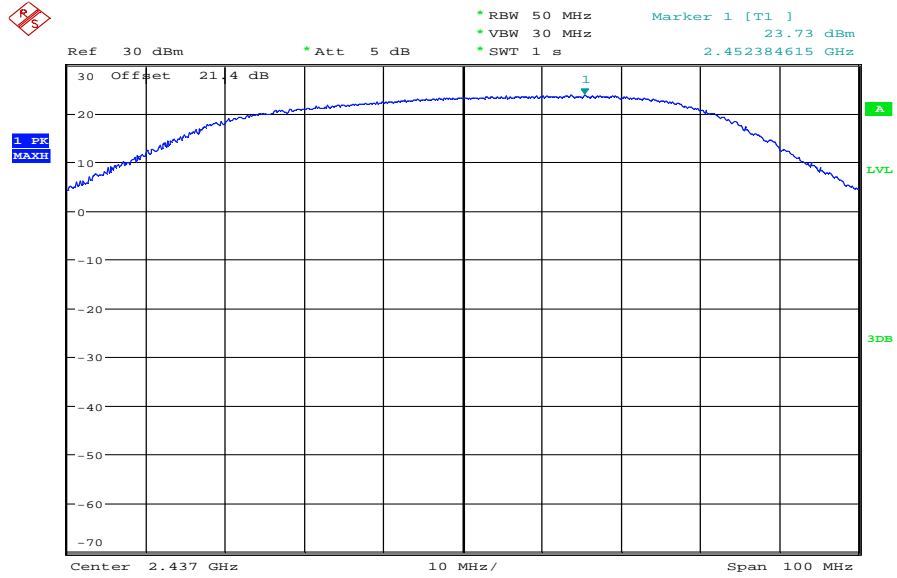

Date: 11.FEB.2011 11:34:33

**Plot 2: TX mode, middle channel, MCS1**

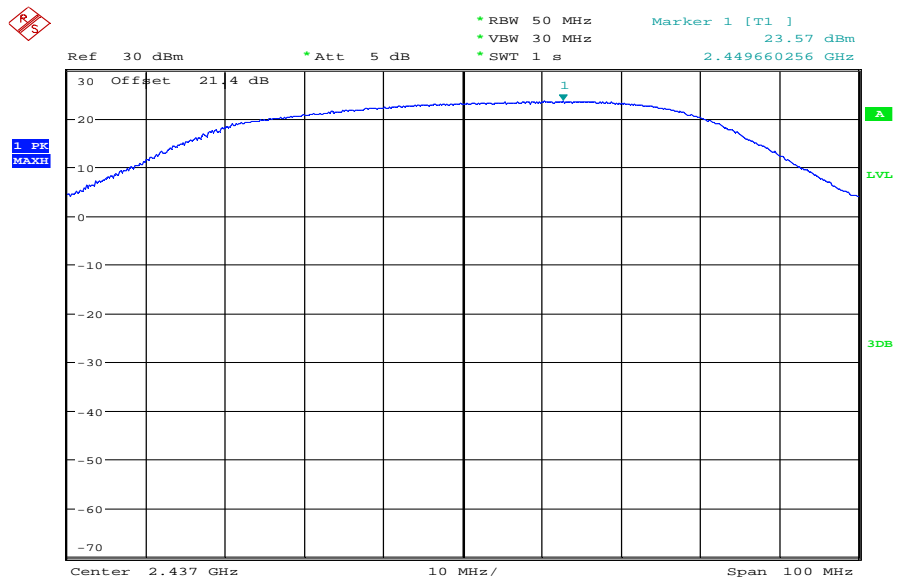

Date: 11.FEB.2011 11:36:53



Plot 3: TX mode, middle channel, MCS2

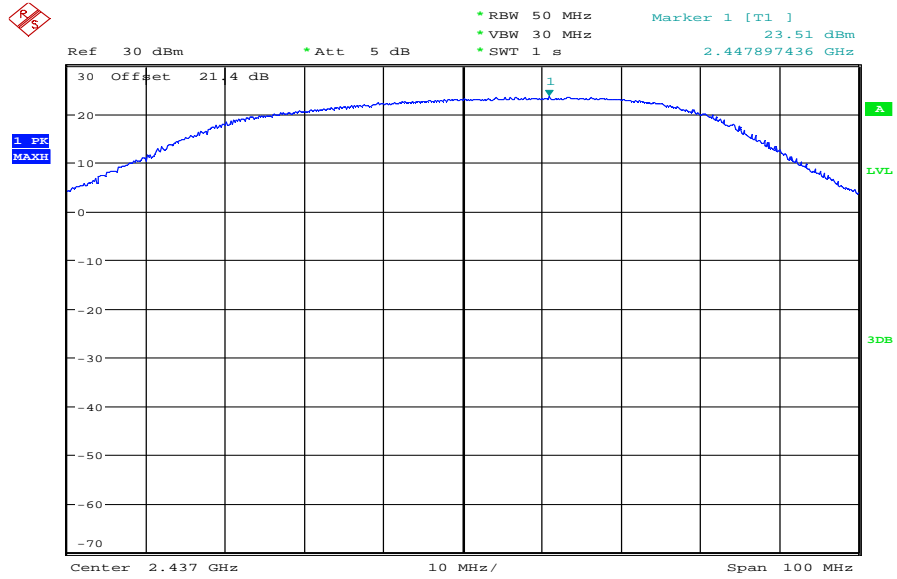

Date: 11.FEB.2011 11:37:58

Plot 4: TX mode, middle channel, MCS3

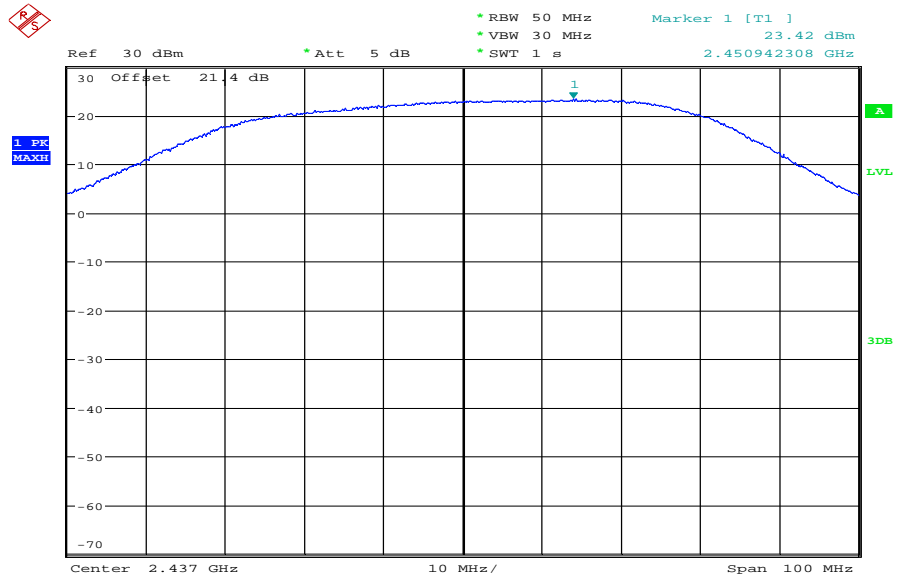

Date: 11.FEB.2011 11:39:04

Plot 5: TX mode, middle channel, MCS4

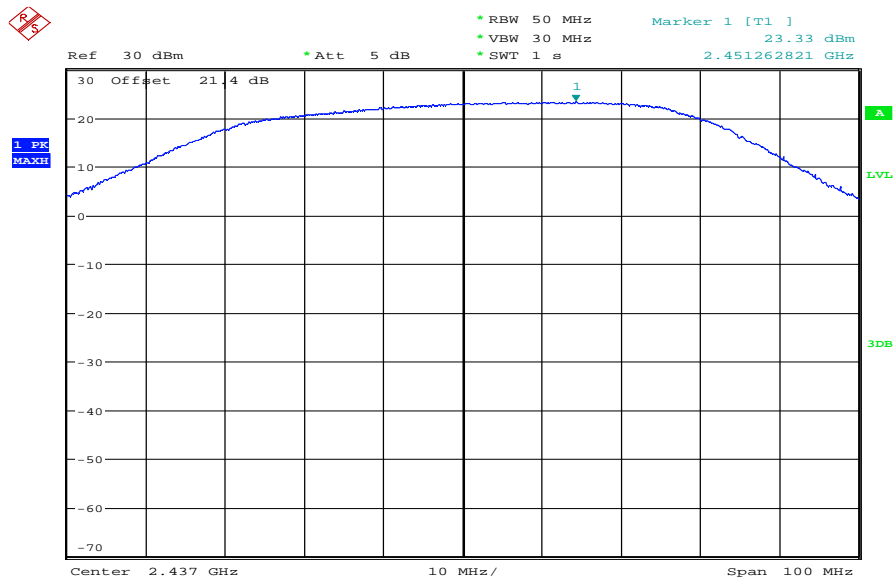

Date: 11.FEB.2011 11:40:09

Plot 6: TX mode, middle channel, MCS5

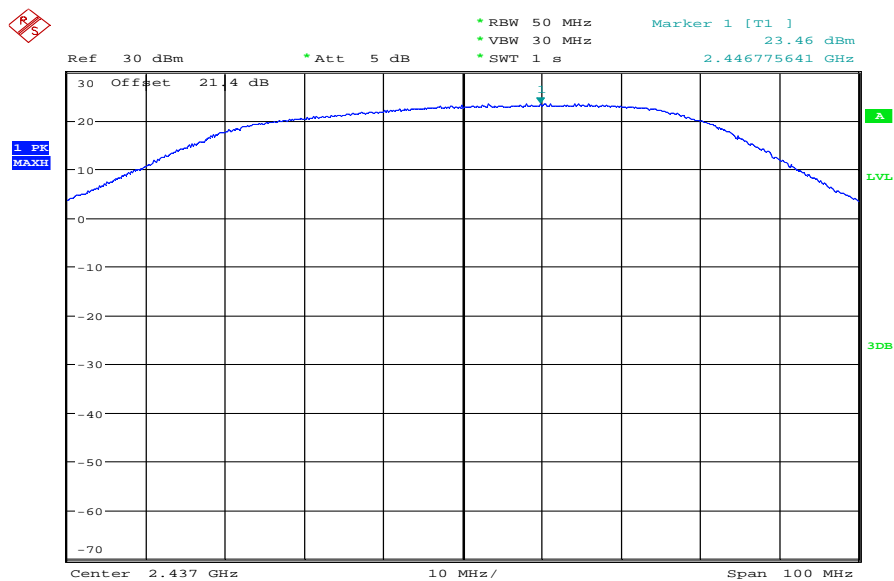

Date: 11.FEB.2011 11:41:16

Plot 7: TX mode, middle channel, MCS6

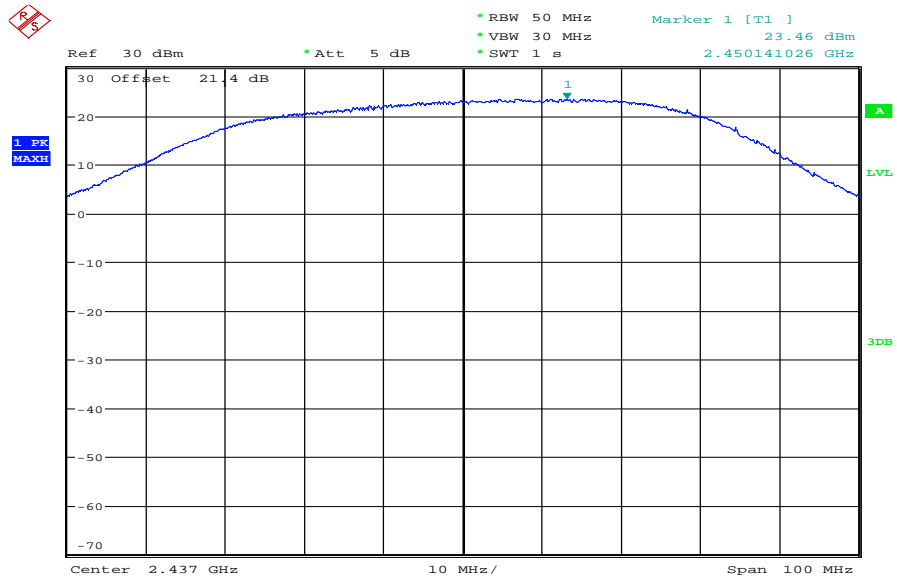

Date: 11.FEB.2011 11:42:21

Plot 8: TX mode, middle channel, MCS7

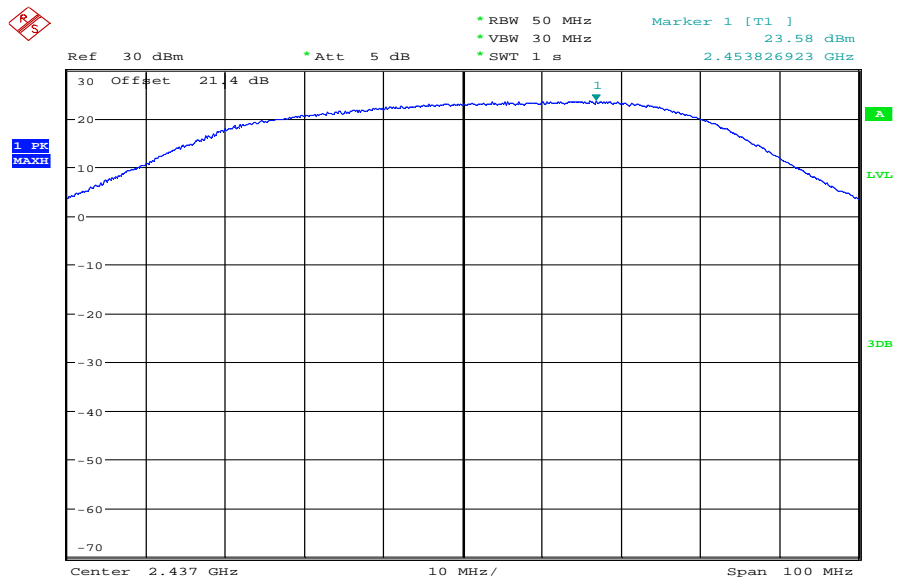

Date: 11.FEB.2011 11:43:22

## 9.2 Antenna gain

### Measurement:

The antenna gain of the complete system is calculated by the difference of radiated power in EIRP and the conducted power of the module. For normal WLAN devices, the DSSS mode is used.

### Measurement parameters:

Measurement parameter	
Detector:	Peak
Sweep time:	1s / Auto
Video bandwidth:	3 MHz
Resolution bandwidth:	3 MHz
Span:	30 MHz
Trace-Mode:	Max hold

### Limits:

FCC	IC
CFR Part 15.247 (b)(4)	RSS 210, Issue 8, A 8.4(2)
Antenna Gain	
6 dBi	

### Results:

$T_{nom}$	$V_{nom}$	lowest channel 2412 MHz	middle channel 2437 MHz	highest channel 2462 MHz
Conducted power [dBm] Measured with DSSS modulation		18.89	18.55	18.40
Radiated power [dBm] Measured with DSSS modulation		17.42	16.77	16.81
Gain [dBi] Calculated		-1.47	-1.78	-1.59

**Result: The result of the measurement is passed.**

**Plots:** DSSS / b – mode, conducted plots

**Plot 1:** TX mode, lowest channel, 5.5 MBit/s

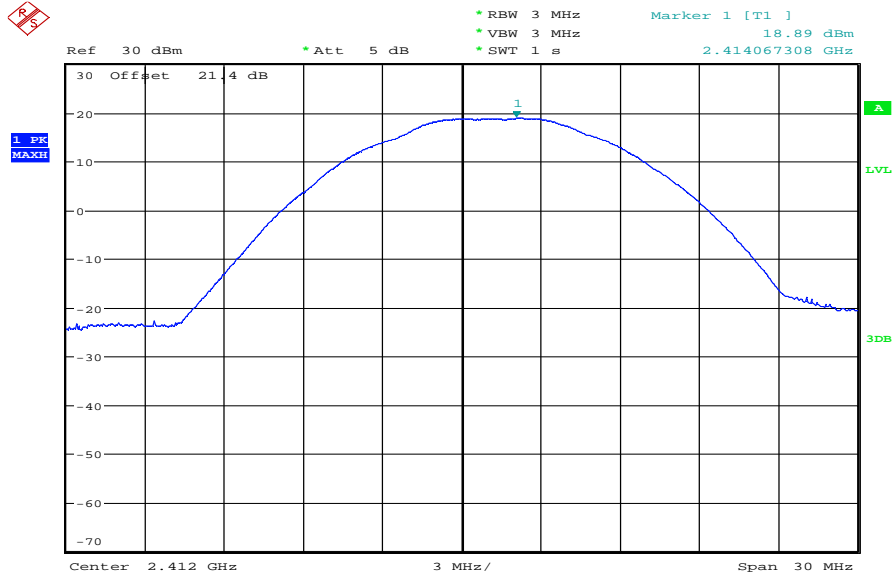

Date: 11.FEB.2011 11:48:45

**Plot 2:** TX mode, middle channel, 5.5 MBit/s

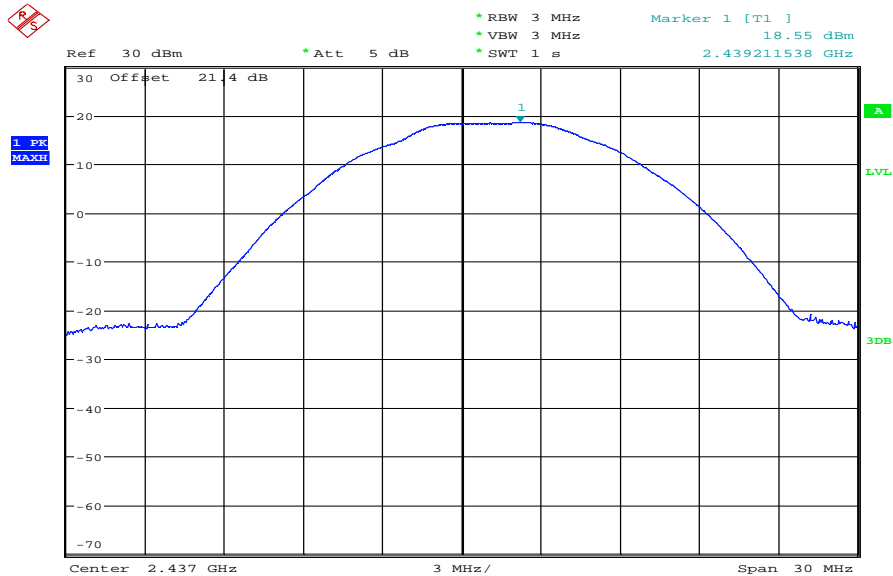

Date: 11.FEB.2011 11:49:53

Plot 3: TX mode, highest channel, 5.5 MBit/s

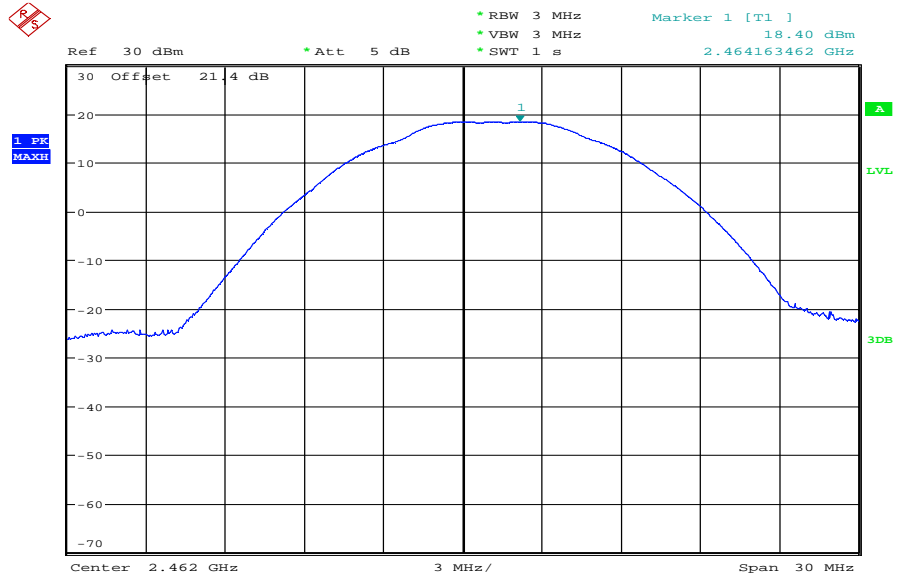

Date: 11.FEB.2011 11:50:53

### 9.3 Power spectral density

#### Description:

Measurement of the power spectral density of a digital modulated system. The measurement is repeated for both modulations at the lowest, middle and highest channel.

#### Measurement:

Measurement parameter	
Detector:	Peak
Sweep time:	500 s
Video bandwidth:	10 kHz
Resolution bandwidth:	3 kHz
Span:	1.5 MHz
Trace-Mode:	Max Hold

#### Limits:

FCC	IC
CFR Part 15.247 (e)	RSS 210, Issue 8, A 8.2(b)
Power Spectral Density	
The transmitter power spectral density conducted from the transmitter to the antenna shall not be greater than 8 dBm in any 3 kHz band during any time interval of continuous transmission or over 1.0 second if the transmission exceeds 1.0-second duration.	

#### Results:

Modulation Frequency	Power Spectral density [dBm/3kHz]		
	2412 MHz	2437 MHz	2462 MHz
DSSS / b – mode	-3.10	-3.94	-3.67
OFDM / g – mode	-6.33	-7.63	-6.76
OFDM / n – mode	-9.14	-10.62	-9.42
Measurement uncertainty	± 0.5 dB		

Result: **The result of the measurement is passed.**

**Plots: DSSS / b – mode**

**Plot 1: TX mode, lowest channel**

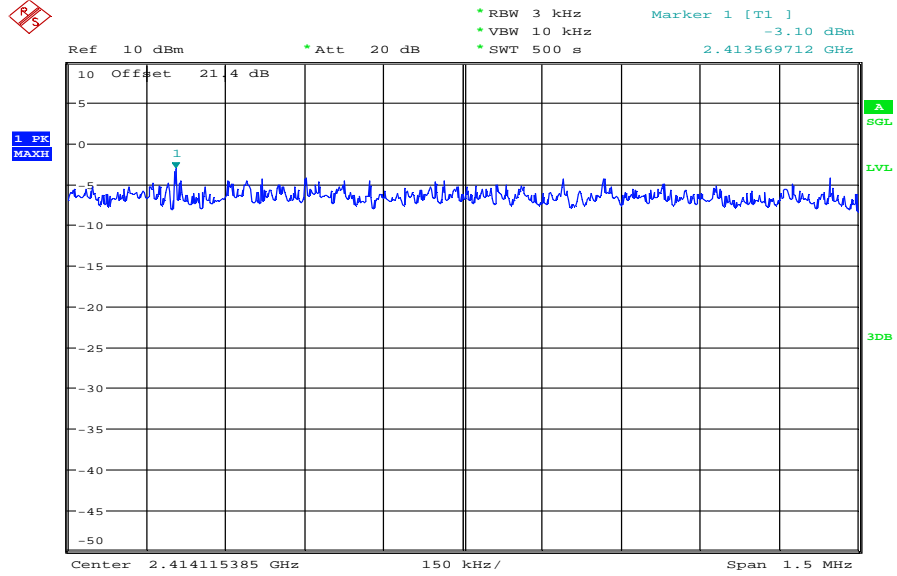

Date: 12.FEB.2011 09:19:09

**Plot 2: TX mode, middle channel**

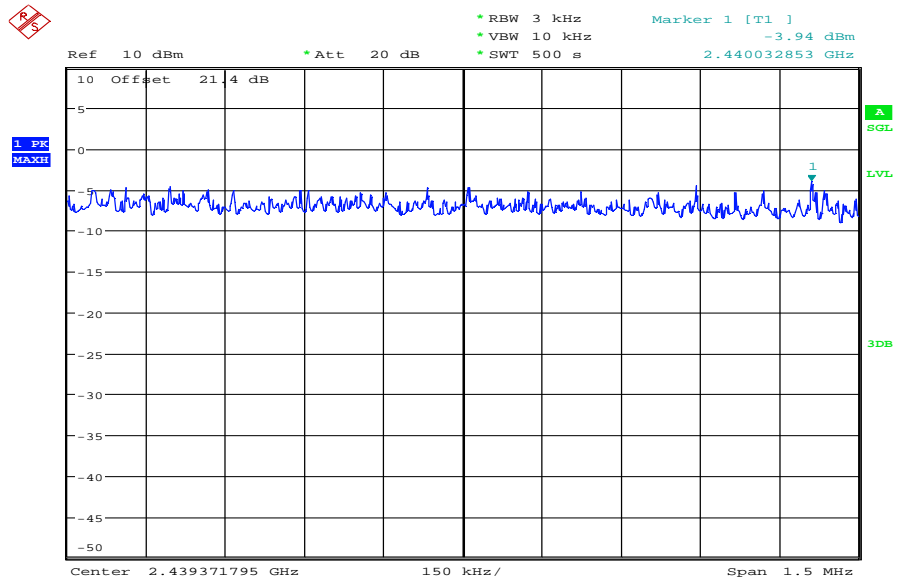

Date: 12.FEB.2011 09:30:37



Plot 3: TX mode, highest channel

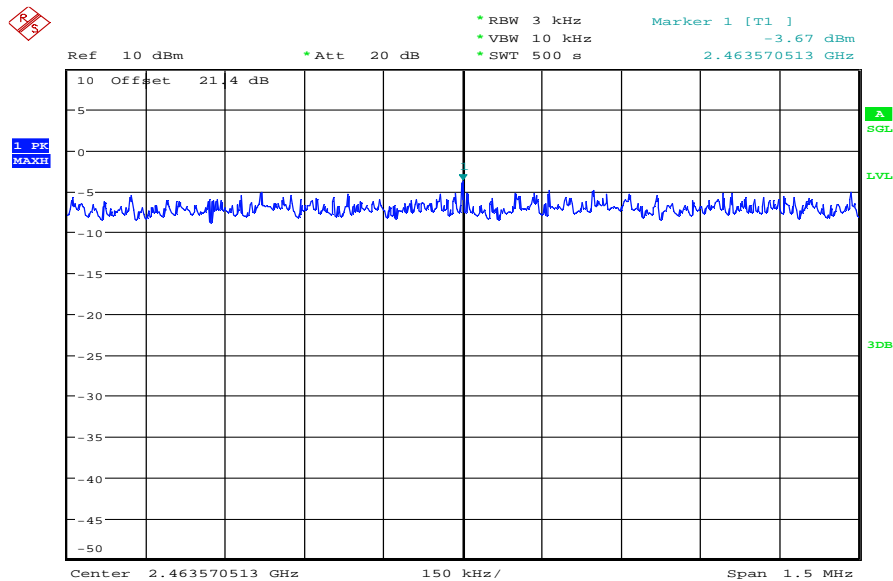

Date: 12.FEB.2011 09:40:21

Plots: OFDM / g – mode

Plot 1: TX mode, lowest channel

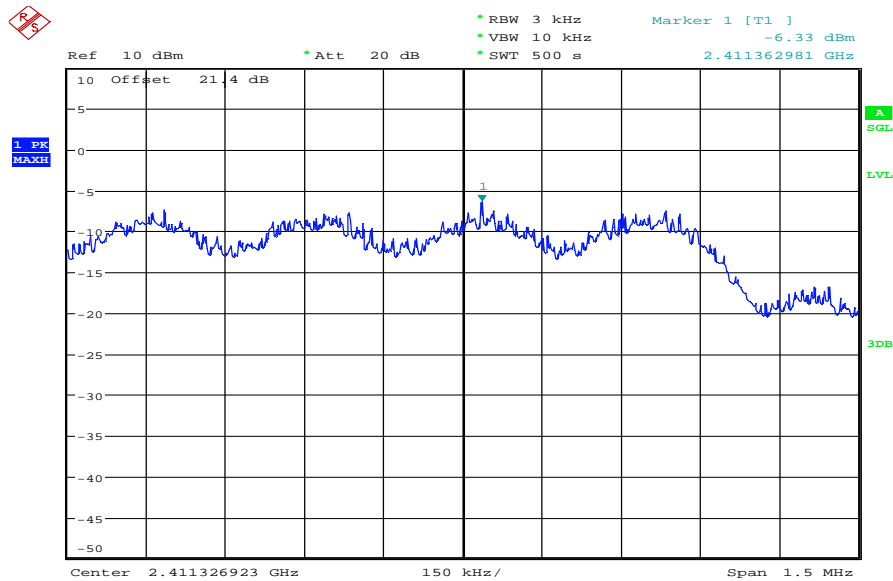

Date: 12.FEB.2011 10:09:08



**Plots: OFDM / n – mode**

**Plot 1: TX mode, lowest channel**

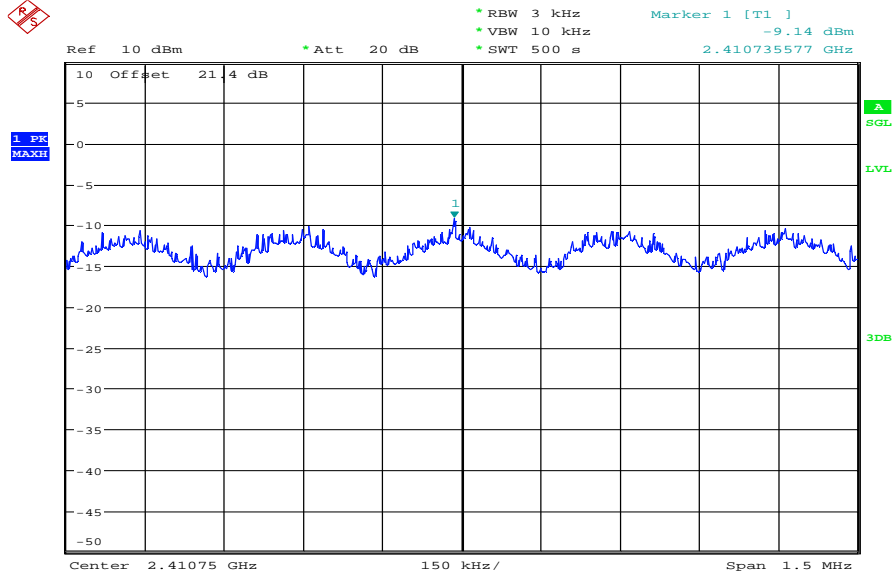

Date: 12.FEB.2011 10:53:48

**Plot 2: TX mode, middle channel**

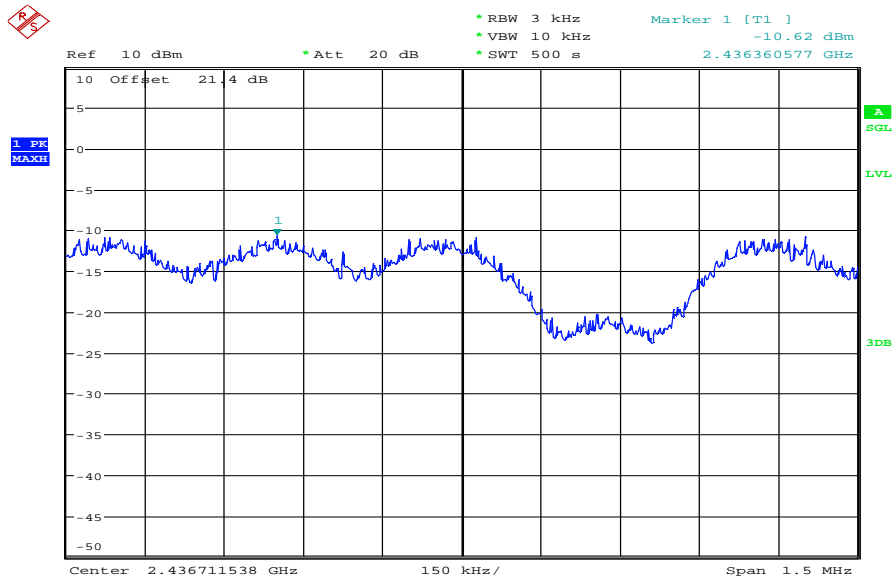

Date: 12.FEB.2011 10:28:33



## 9.4 Spectrum bandwidth of a FHSS system – 6 dB bandwidth

### Description:

Measurement of the 6 dB bandwidth of the modulated signal.

### Measurement:

Measurement parameter	
Detector:	Peak
Sweep time:	Auto
Video bandwidth:	100 kHz
Resolution bandwidth:	100 kHz
Span:	30 MHz
Trace-Mode:	Max Hold

### Limits:

FCC	IC
CFR Part 15.247 (a)(2)	RSS 210, Issue 8, A 8.2(a)
Spectrum Bandwidth of a FHSS System – 6 dB Bandwidth	
Systems using digital modulation techniques may operate in the 2400–2483.5 MHz band. The minimum 6 dB bandwidth shall be at least 500 kHz.	

### Results:

Modulation Frequency	6 dB BANDWIDTH [MHz]		
	2412 MHz	2437 MHz	2462 MHz
DSSS / b – mode	8.37	8.22	8.22
OFDM / g – mode	15.53	15.77	15.53
OFDM / n – mode	15.34	15.19	15.19
Measurement uncertainty	± 100 kHz		

**Result:** The result of the measurement is passed.

**Plots: DSSS / b – mode**

**Plot 1: TX mode, lowest channel, 6 dB bandwidth**

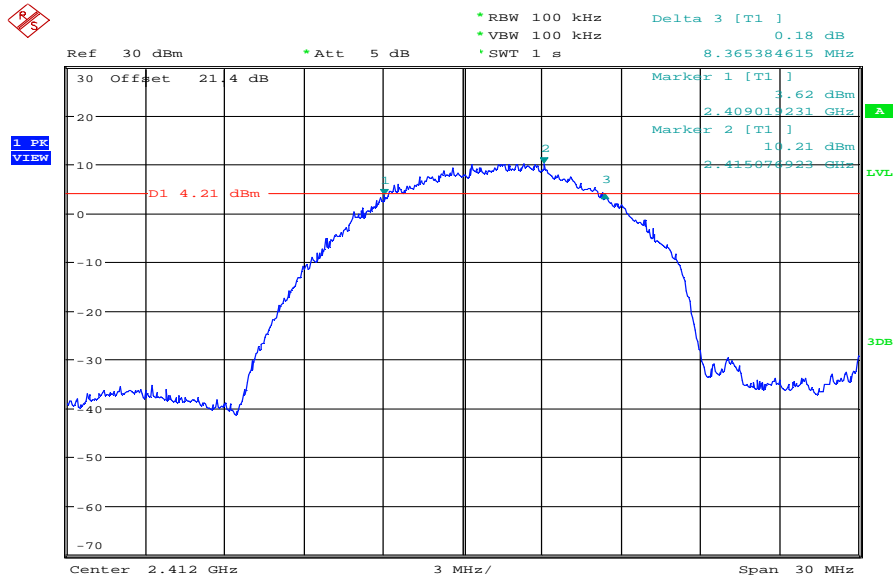

Date: 11.FEB.2011 13:00:04

**Plot 2: TX mode, middle channel, 6 dB bandwidth**

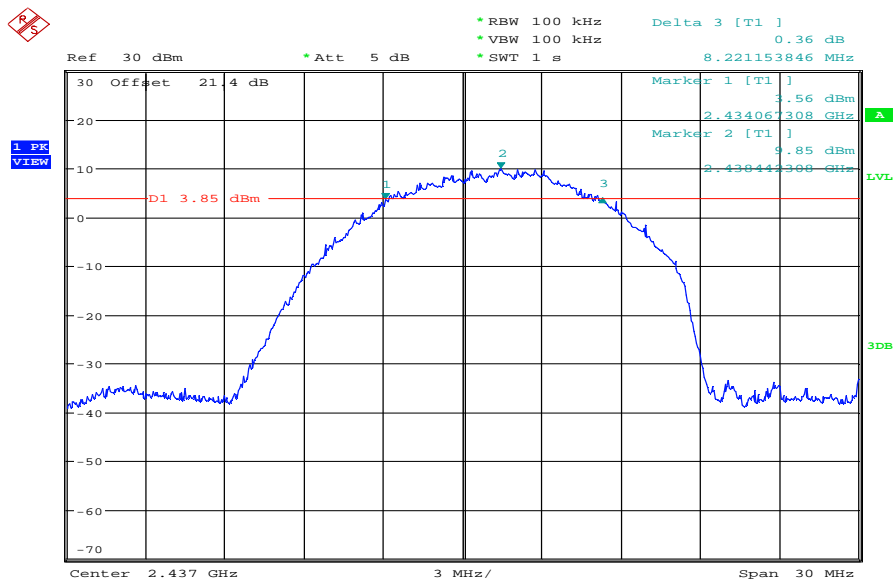

Date: 11.FEB.2011 13:02:45

**Plot 3: TX mode, highest channel, 6 dB bandwidth**

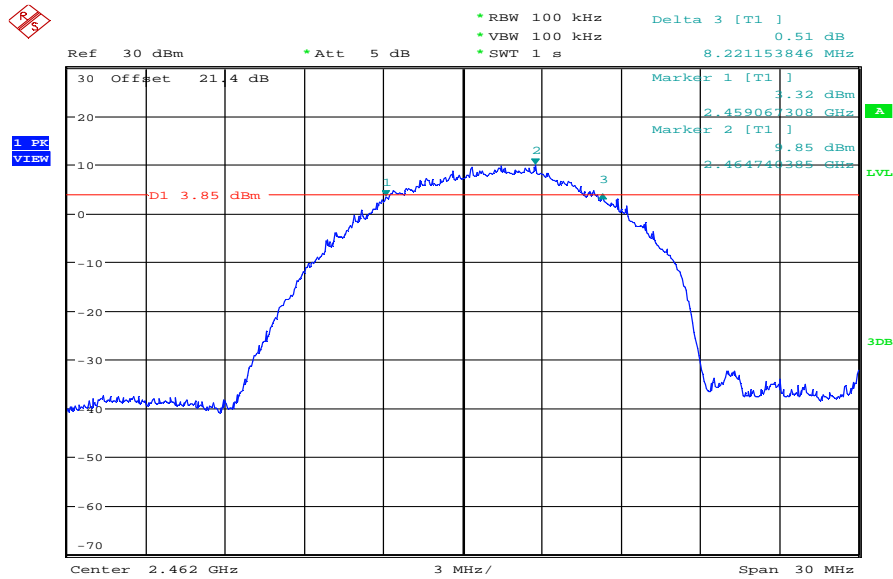

Date: 11.FEB.2011 13:05:24

**Plots: OFDM / g – mode**

**Plot 1: TX mode, lowest channel, 6 dB bandwidth**

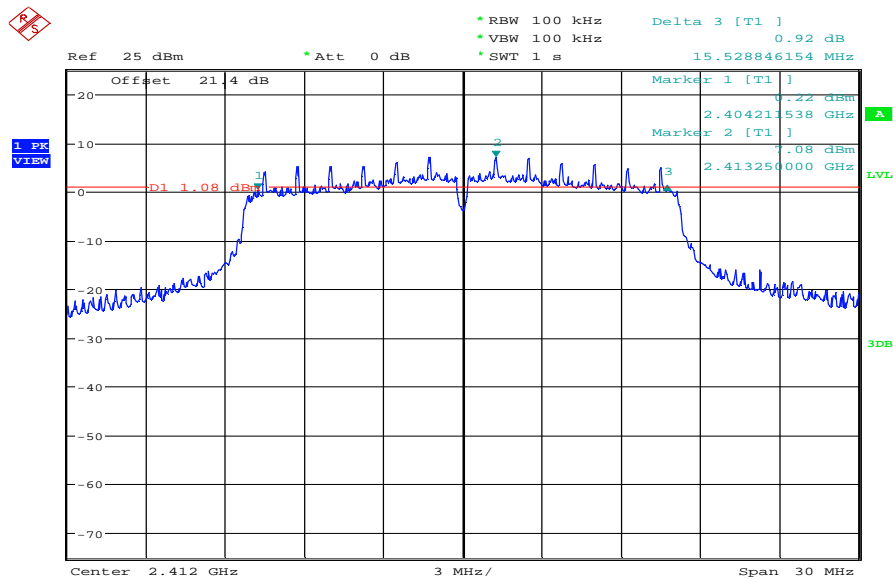

Date: 11.FEB.2011 13:14:21

Plot 2: TX mode, middle channel, 6 dB bandwidth

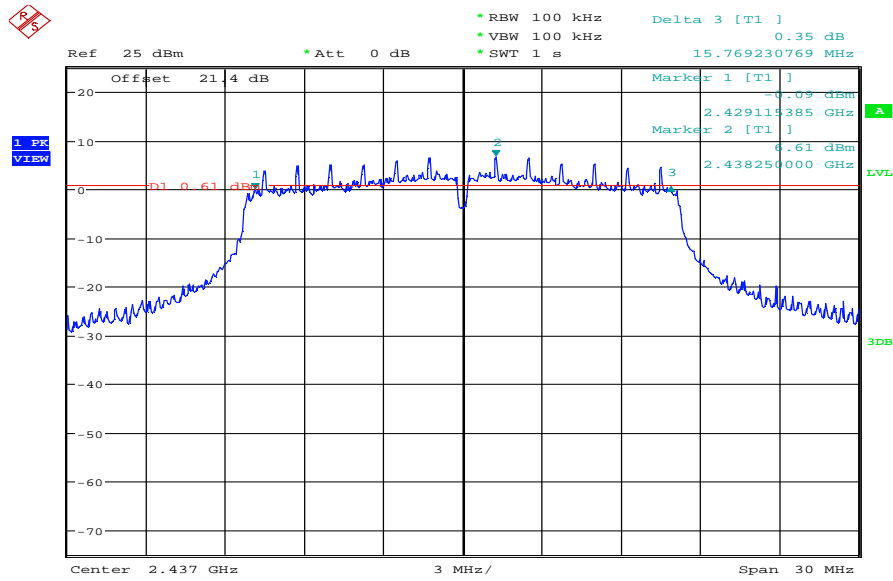

Date: 11.FEB.2011 13:17:39

Plot 3: TX mode, highest channel, 6 dB bandwidth

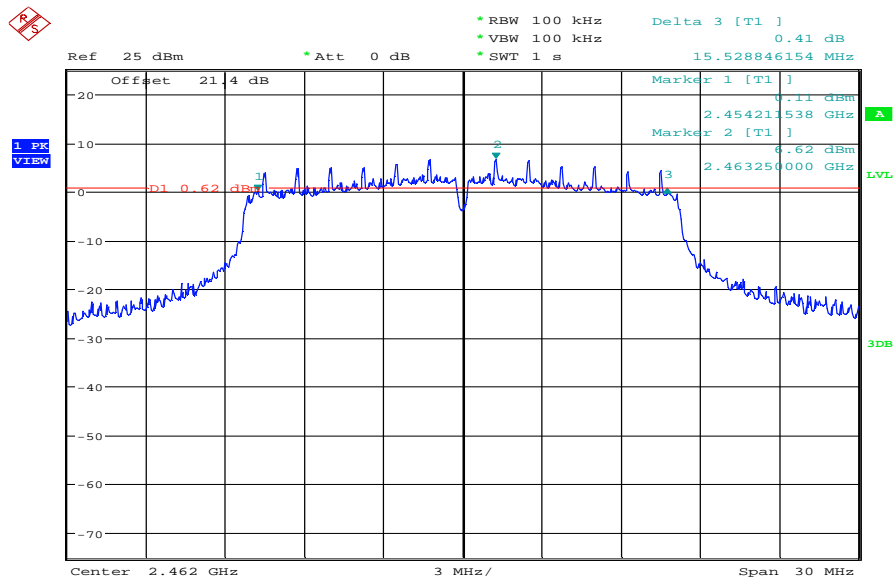

Date: 11.FEB.2011 13:20:52



**Plots: OFDM / n – mode**

**Plot 1: TX mode, lowest channel, 6 dB bandwidth**

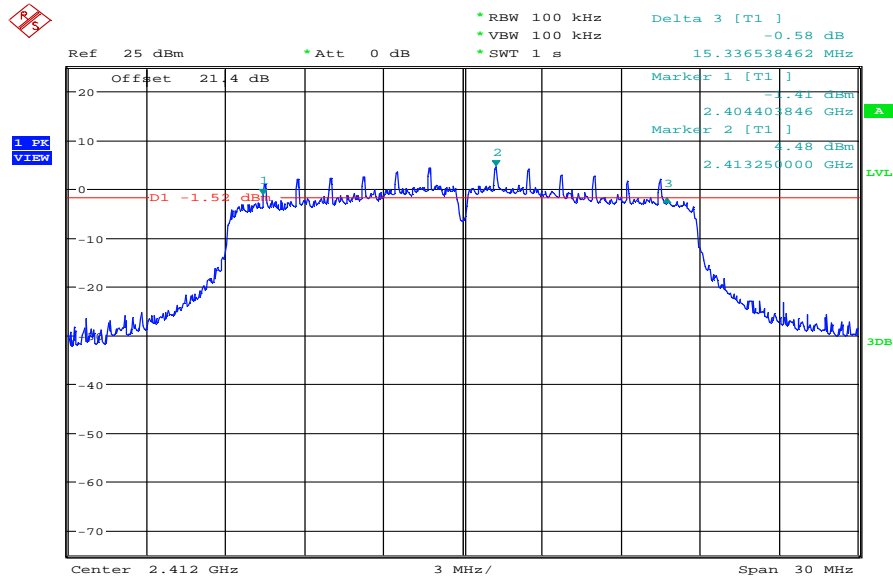

Date: 11.FEB.2011 13:28:36

**Plot 2: TX mode, middle channel, 6 dB bandwidth**

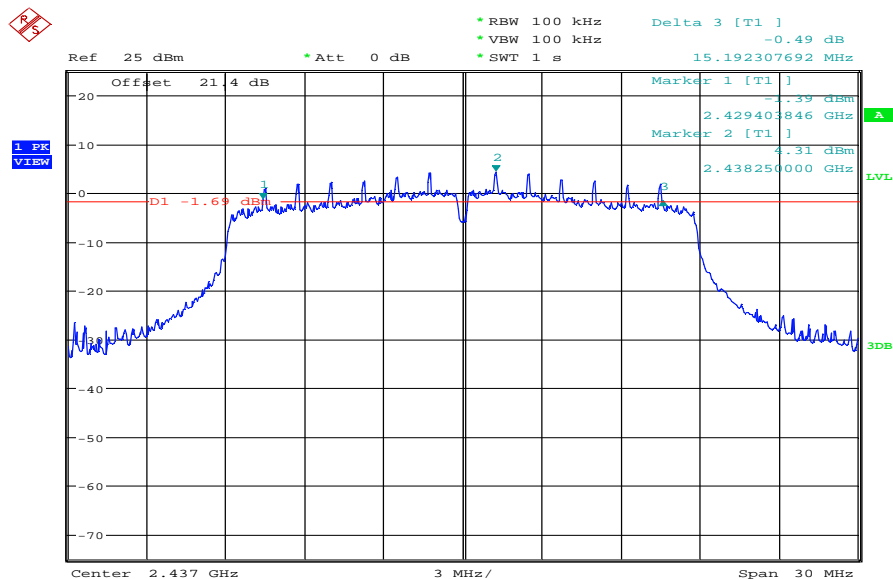

Date: 11.FEB.2011 13:34:12

Plot 3: TX mode, highest channel, 6 dB bandwidth

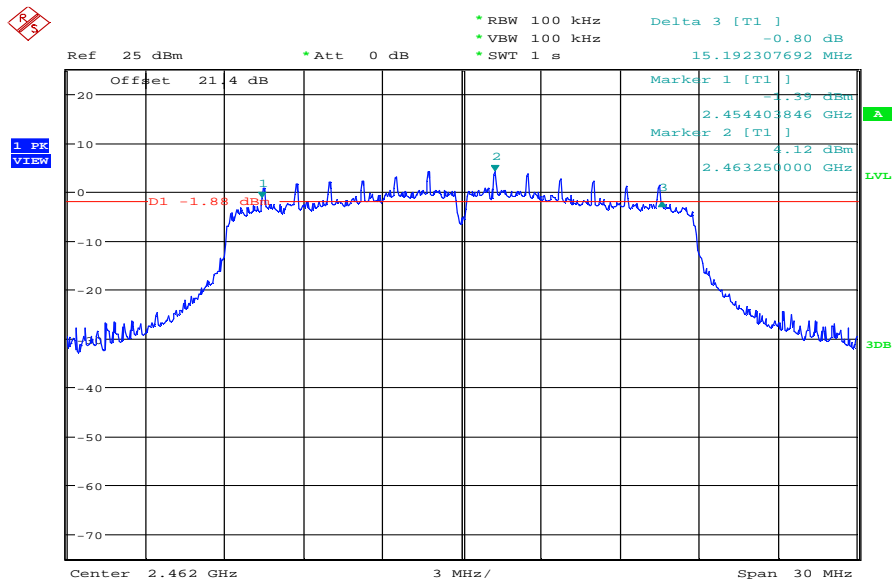

Date: 11.FEB.2011 13:38:09

## 9.5 Spectrum bandwidth of a FHSS system – 20 dB bandwidth

### Description:

Measurement of the 20 dB bandwidth of the modulated signal.

### Measurement:

Measurement parameter	
Detector:	Peak
Sweep time:	Auto
Video bandwidth:	100 kHz
Resolution bandwidth:	100 kHz
Span:	30 MHz
Trace-Mode:	Max Hold

### Limits:

FCC	IC
CFR Part 15.247 (a)(2)	RSS 210, Issue 8, A 8.2(a)
Spectrum Bandwidth of a FHSS System – 20 dB Bandwidth	
Systems using digital modulation techniques may operate in the 2400–2483.5 MHz band. The minimum 6 dB bandwidth shall be at least 500 kHz.	

### Results:

Modulation Frequency	20 dB BANDWIDTH [MHz]		
	2412 MHz	2437 MHz	2462 MHz
DSSS / b – mode	13.94	13.85	13.89
OFDM / g – mode	17.64	17.60	18.17
OFDM / n – mode	18.75	18.65	18.70
Measurement uncertainty	± 100 kHz		

**Result:** The result of the measurement is passed.

**Plots: DSSS / b – mode**

**Plot 1: TX mode, lowest channel, 20 dB bandwidth**

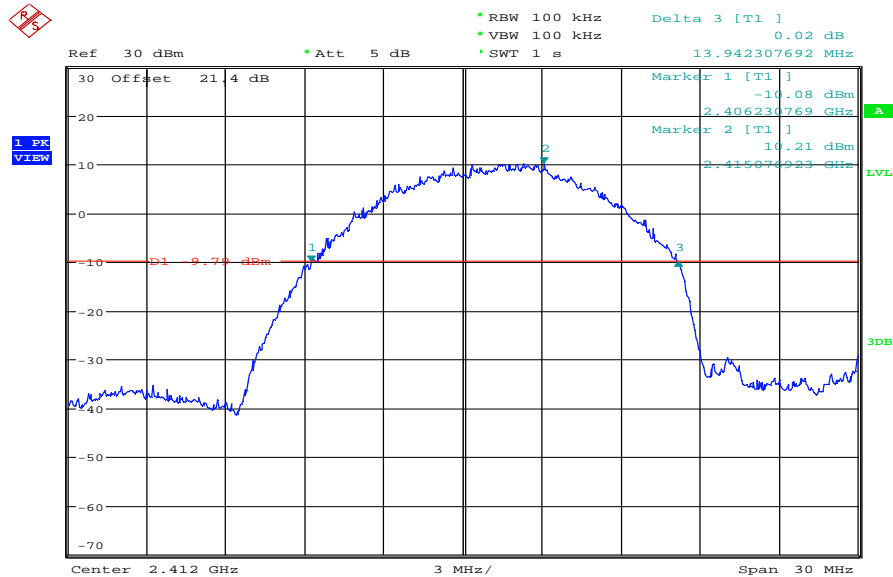

Date: 11.FEB.2011 13:00:47

**Plot 2: TX mode, middle channel, 20 dB bandwidth**

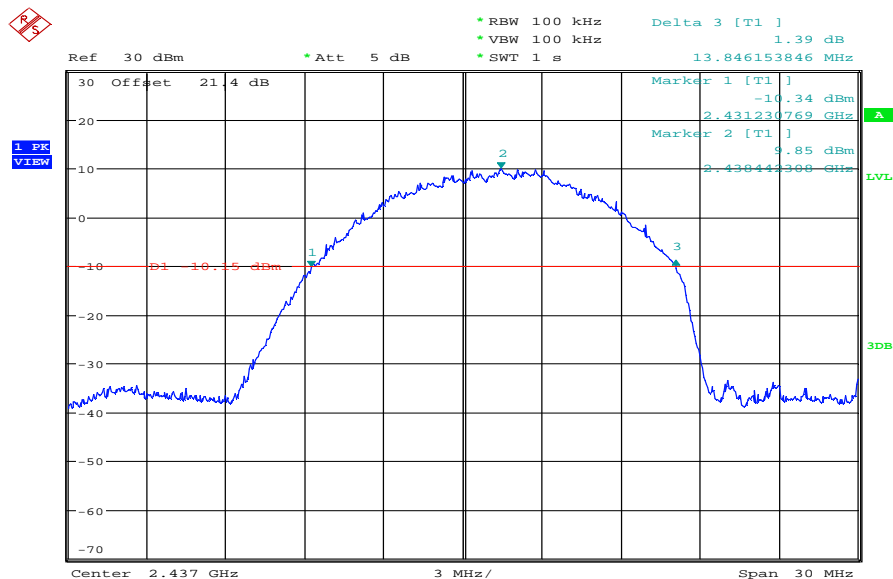

Date: 11.FEB.2011 13:03:29

Plot 3: TX mode, highest channel, 20 dB bandwidth

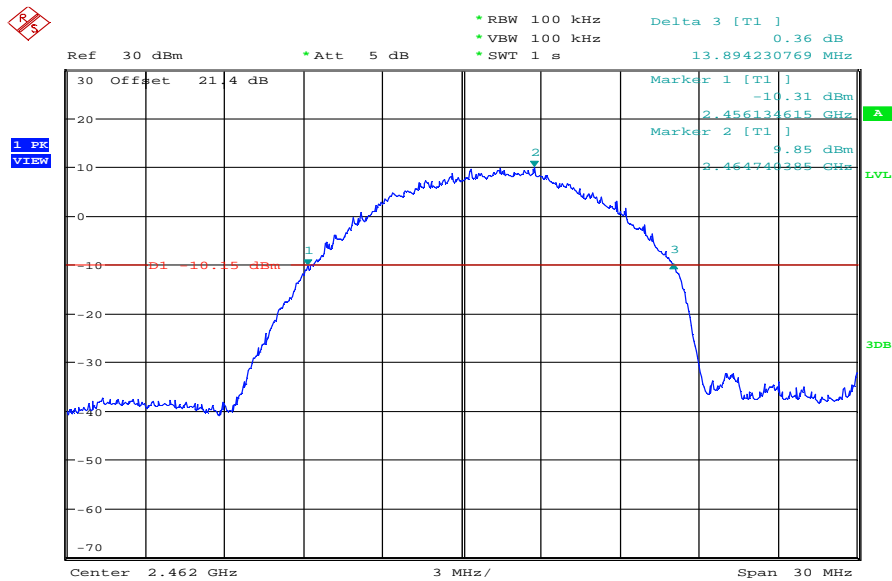

Date: 11.FEB.2011 13:05:58

**Plots: OFDM / g – mode**

Plot 1: TX mode, lowest channel, 20 dB bandwidth

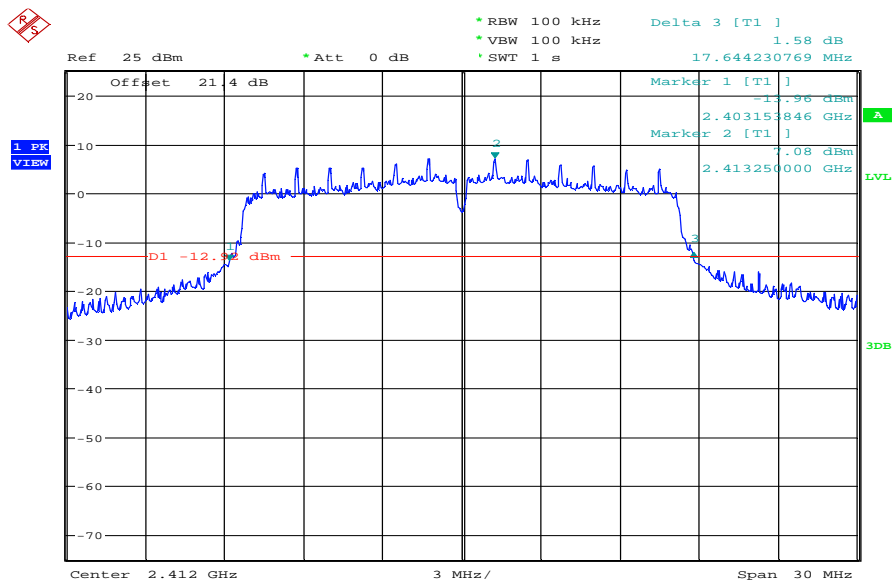

Date: 11.FEB.2011 13:14:53

Plot 2: TX mode, middle channel, 20 dB bandwidth

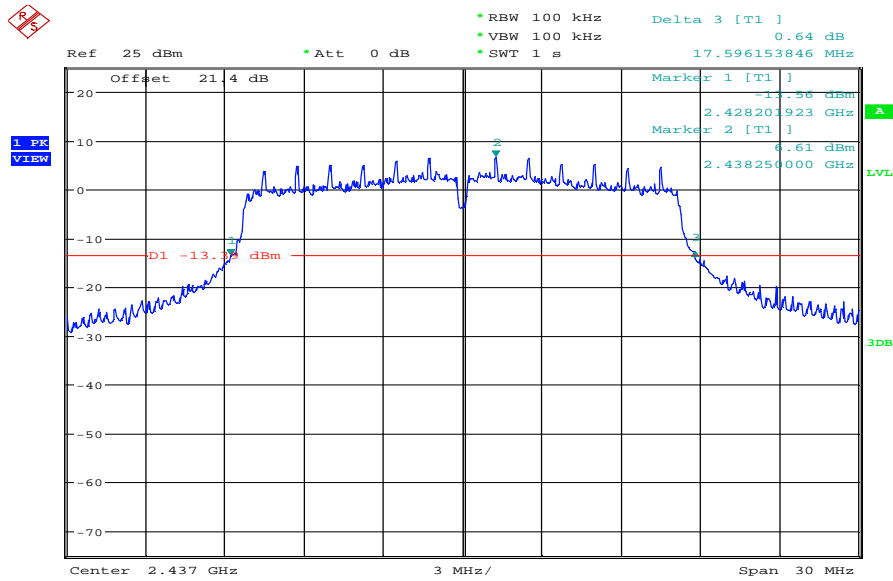

Date: 11.FEB.2011 13:18:26

Plot 3: TX mode, highest channel, 20 dB bandwidth

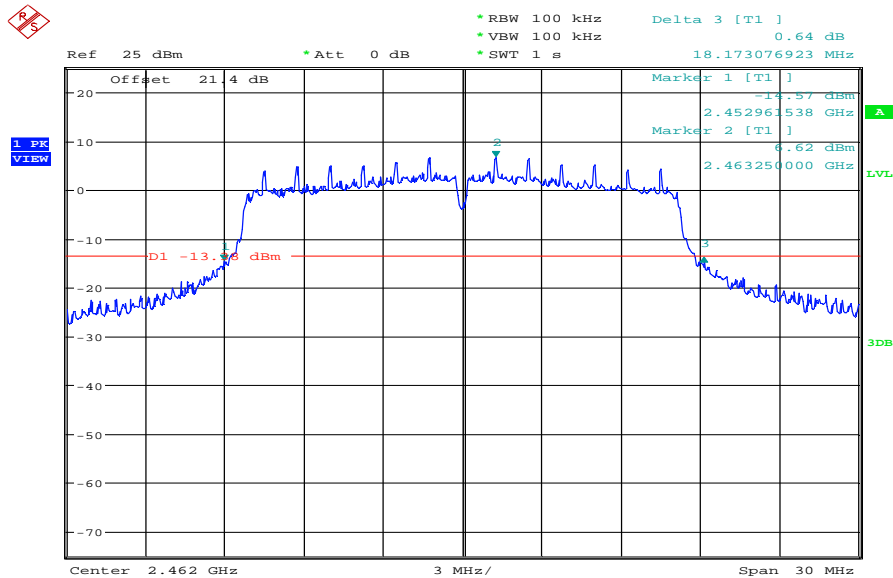

Date: 11.FEB.2011 13:21:26

**Plots: OFDM / n – mode**

**Plot 1: TX mode, lowest channel, 20 dB bandwidth**

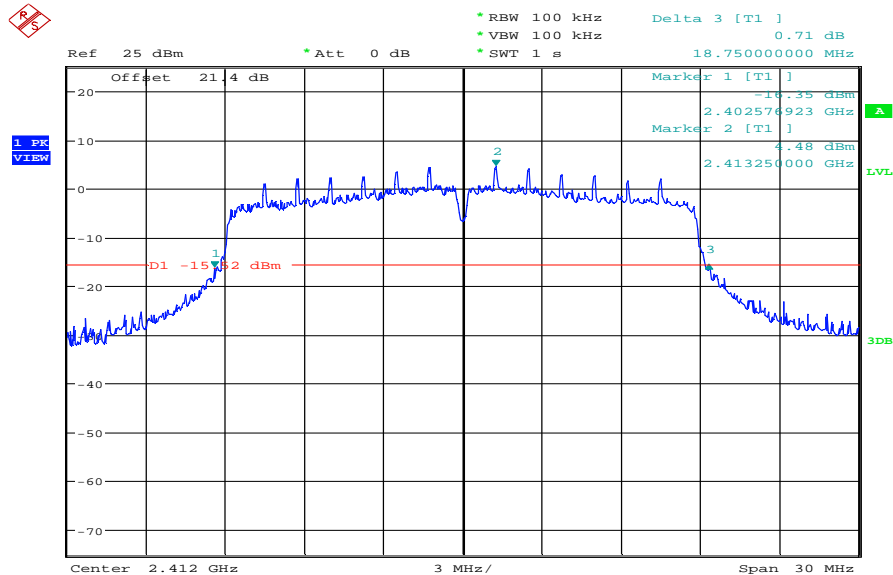

Date: 11.FEB.2011 13:29:11

**Plot 2: TX mode, middle channel, 20 dB bandwidth**

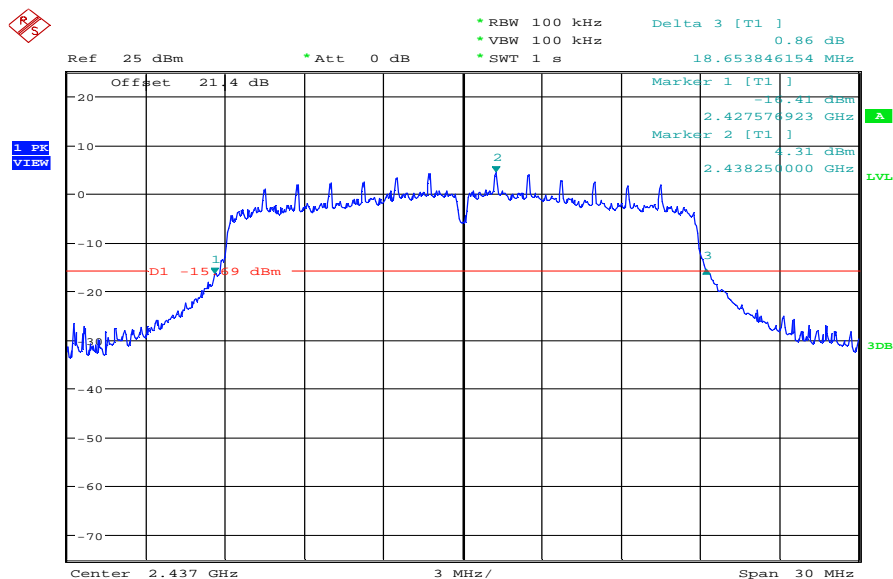

Date: 11.FEB.2011 13:34:48

Plot 3: TX mode, highest channel, 20 dB bandwidth

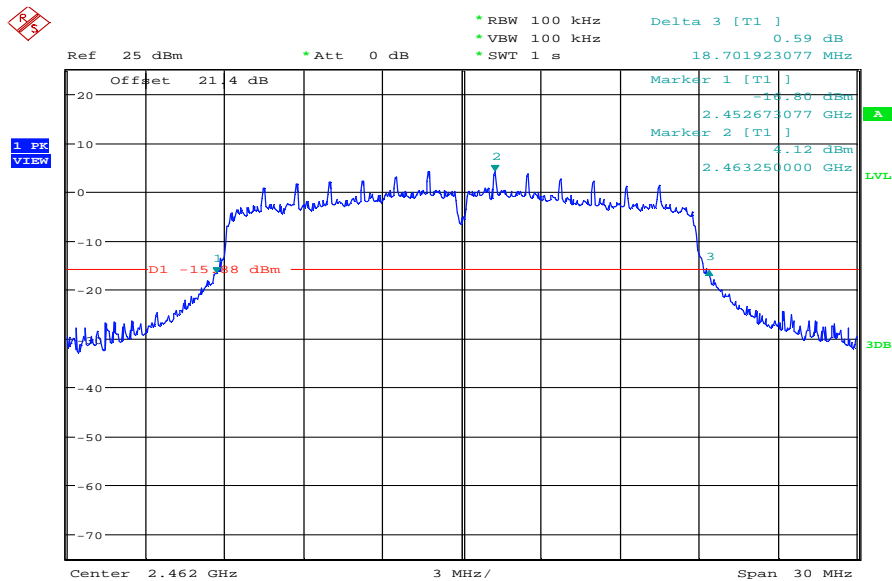

Date: 11.FEB.2011 13:39:04



## 9.6 Maximum output power

### Description:

Measurement of the maximum output power conducted and radiated. The measurements are performed using the data rate producing the highest conducted output power. The determination of these data rates was performed at the beginning of the tests. Additionally the average power is measured using a wideband power meter.

### Measurement:

Measurement parameter	
Detector:	Peak
Sweep time:	1s / Auto
Video bandwidth:	30 MHz
Resolution bandwidth:	50 MHz
Span:	100 MHz
Trace-Mode:	Max Hold

### Limits:

FCC	IC
CFR Part 15.247 (b)(3)	RSS 210, Issue 8, A 8.4(4)
Maximum Output Power	
Conducted: 1.0 W – Antenna Gain max. 6 dBi	

### Results: DSSS / b – mode

DSSS / b – mode Frequency	Maximum Output Power [dBm]		
	2412 MHz	2437 MHz	2462 MHz
Peak Output Power Conducted	21.24	21.07	21.03
Output Power Radiated - EIRP	19.77	19.29	19.44
Measurement uncertainty	± 0.5 dB (cond.) / ± 2 dB (rad.)		

**Result:** The result of the measurement is passed.

**Results: OFDM / g – mode**

OFDM / g – mode Frequency	Maximum Output Power [dBm]		
	2412 MHz	2437 MHz	2462 MHz
Peak Output Power Conducted	24.07	24.54	24.06
Output Power Radiated - EIRP	22.60	22.76	22.47
Measurement uncertainty	± 0.5 dB (cond.) / ± 2 dB (rad.)		

**Result:** The result of the measurement is passed.

**Results: OFDM / n – mode**

OFDM / n – mode Frequency	Maximum Output Power [dBm]		
	2412 MHz	2437 MHz	2462 MHz
Peak Output Power Conducted	23.09	23.73	23.06
Output Power Radiated - EIRP	21.62	21.95	21.47
Measurement uncertainty	± 0.5 dB (cond.) / ± 2 dB (rad.)		

**Result:** The result of the measurement is passed.

**Plots: DSSS / b – mode**

**Plot 1: TX mode, lowest channel**

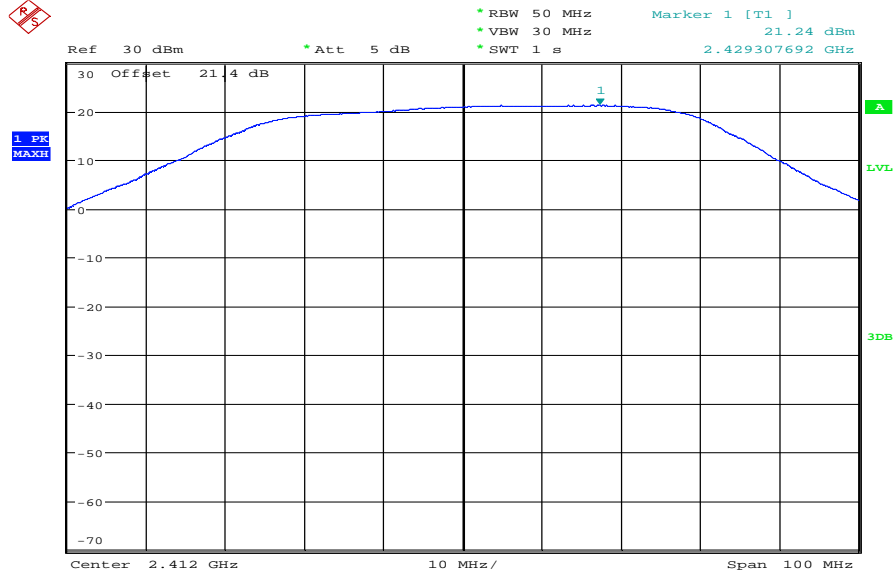

Date: 11.FEB.2011 10:52:49

**Plot 2: TX mode, middle channel**

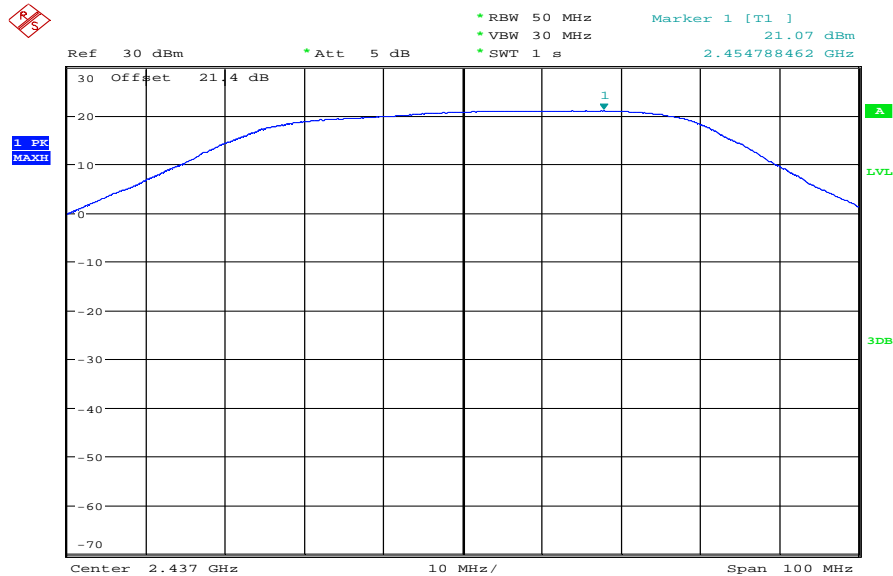

Date: 11.FEB.2011 10:50:13

Plot 3: TX mode, highest channel

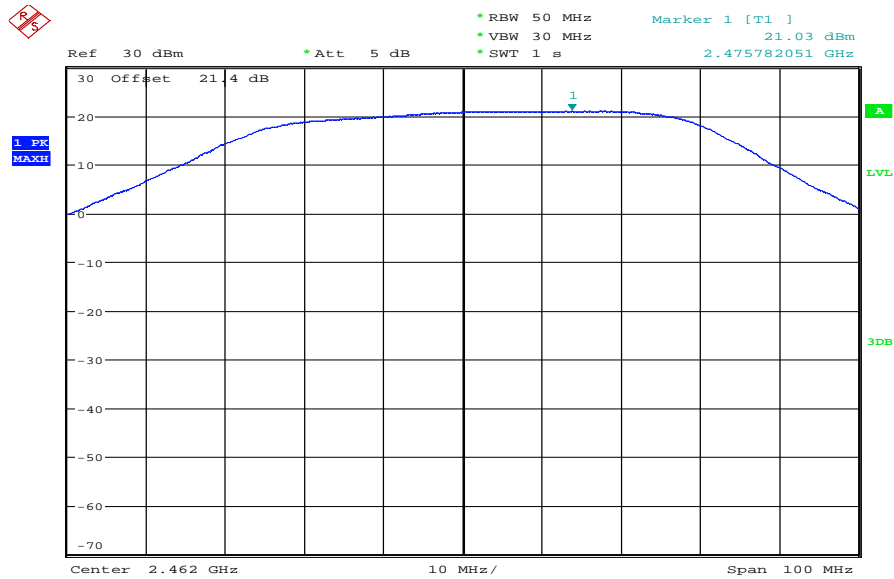

Date: 11.FEB.2011 10:53:52

Plots: OFDM / g – mode

Plot 1: TX mode, lowest channel

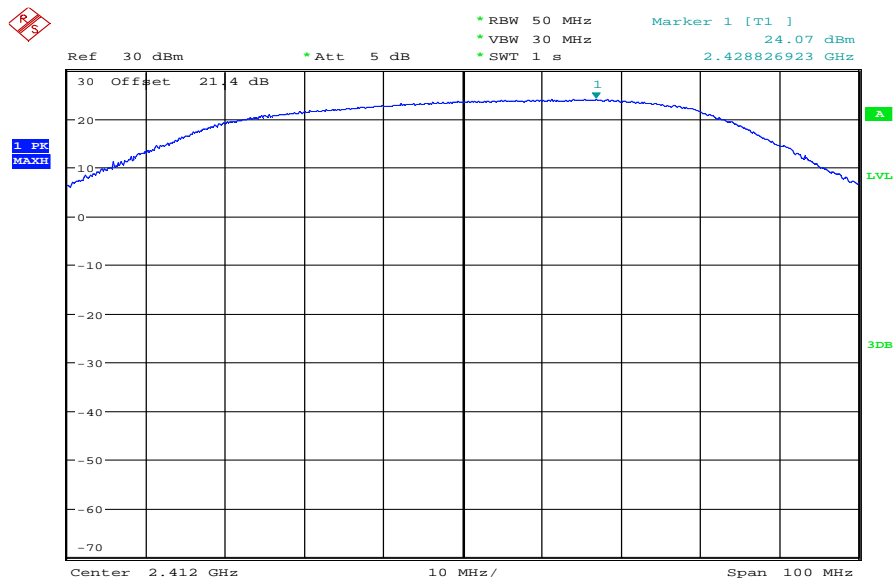

Date: 11.FEB.2011 11:31:09

Plot 2: TX mode, middle channel

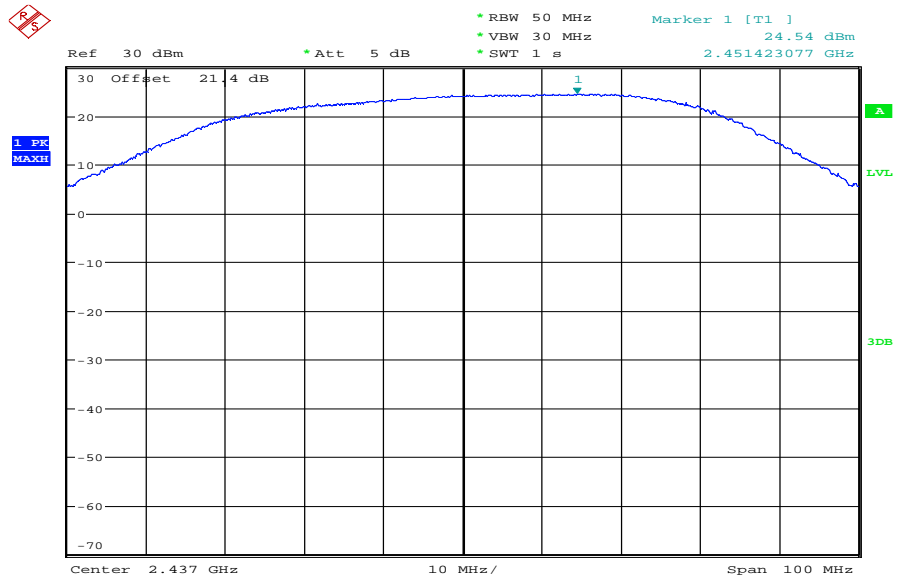

Date: 11.FEB.2011 11:22:35

Plot 3: TX mode, highest channel

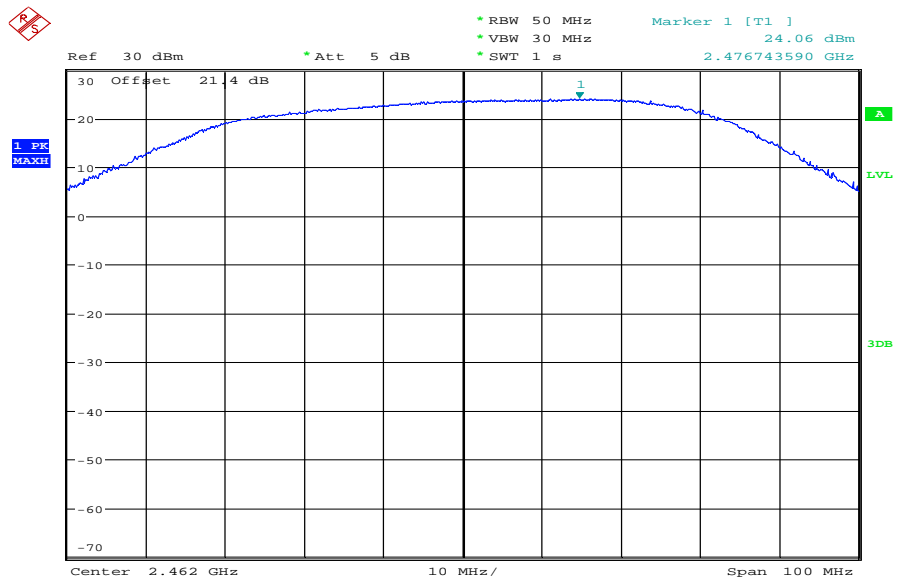

Date: 11.FEB.2011 11:33:02

**Plots: OFDM / n – mode**

**Plot 1: TX mode, lowest channel**

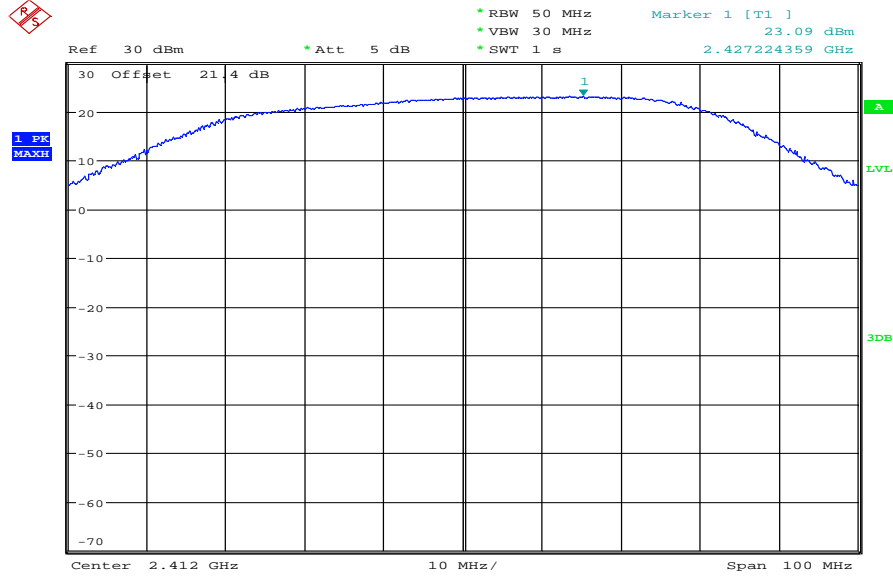

Date: 11.FEB.2011 11:44:59

**Plot 2: TX mode, middle channel**

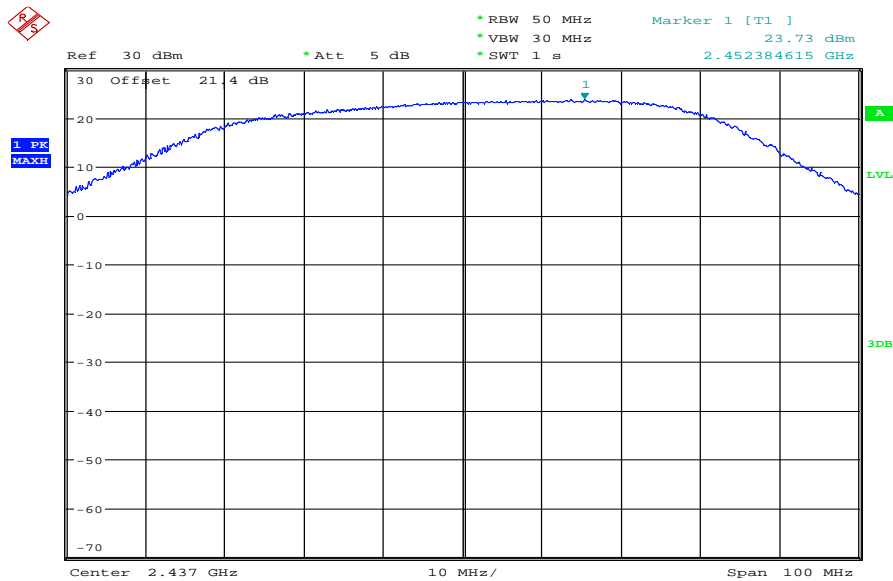

Date: 11.FEB.2011 11:34:33

Plot 3: TX mode, highest channel

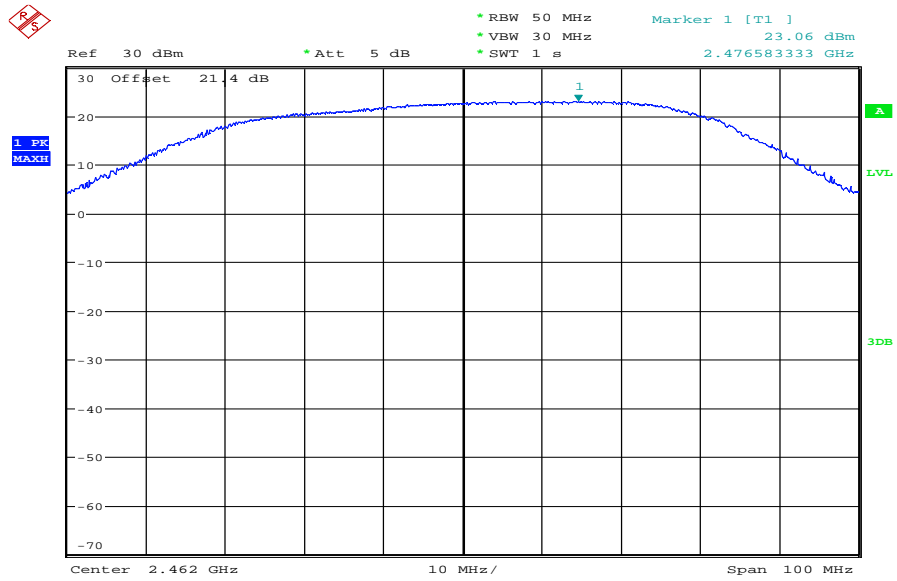

Date: 11.FEB.2011 11:46:26

## 9.7 Band edge compliance conducted

### Description:

Measurement of the conducted band edge compliance. EUT is measured at the lower and upper band edge in both modes.

### Measurement:

Measurement parameter	
Detector:	Peak
Sweep time:	Auto
Video bandwidth:	100 kHz
Resolution bandwidth:	500 kHz
Span:	Lower Band Edge: 2300 – 2425 MHz Upper Band Edge: 2450 – 2500 MHz
Trace-Mode:	Max Hold

### Limits:

FCC	IC
CFR Part 15.247 (d)	RSS 210, Issue 8, A 8.5
Band Edge Compliance Conducted	
<p>In any 100 kHz bandwidth outside the frequency band in which the spread spectrum or digitally modulated intentional radiator is operating, the radio frequency power that is produced by the intentional radiator shall be at least 20 dB below that in the 100 kHz bandwidth within the band that contains the highest level of the desired power, based on either an RF conducted or a radiated measurement. Attenuation below the general limits specified in Section 15.209(a) is not required.</p>	

### Results:

Scenario Modulation	Band Edge Compliance Conducted [dB]	
	DSSS (b – mode)	OFDM (g & n – mode)
Lower Band Edge – Channel 1	> 20 dB (see plot 1)	> 20 dB (see plot 3)
Upper Band Edge – Channel 11	> 20 dB (see plot 2)	> 20 dB (see plot 4)
Measurement uncertainty	± 1.5 dB	

**Result:** The result of the measurement is passed.



**Plots: DSSS / b – mode**

**Plot 1: TX mode, lower band edge**

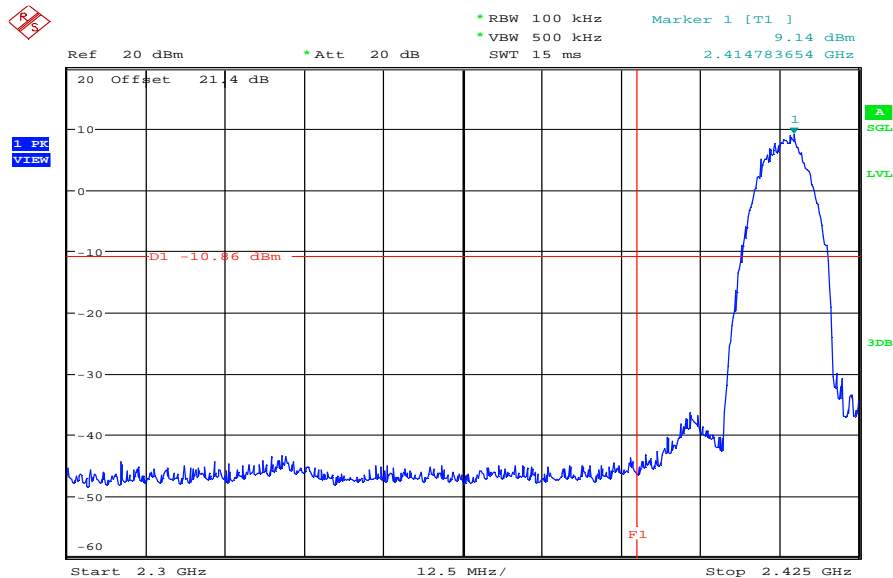

Date: 12.FEB.2011 08:52:36

**Plot 2: TX mode, upper band edge**

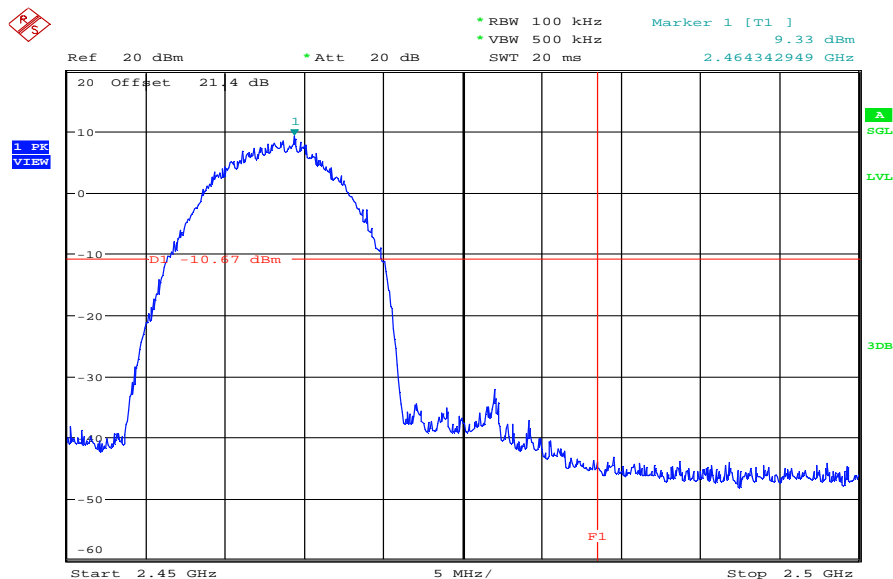

Date: 12.FEB.2011 08:57:52

**Plots: OFDM / g – mode**

**Plot 1: TX mode, lower band edge**

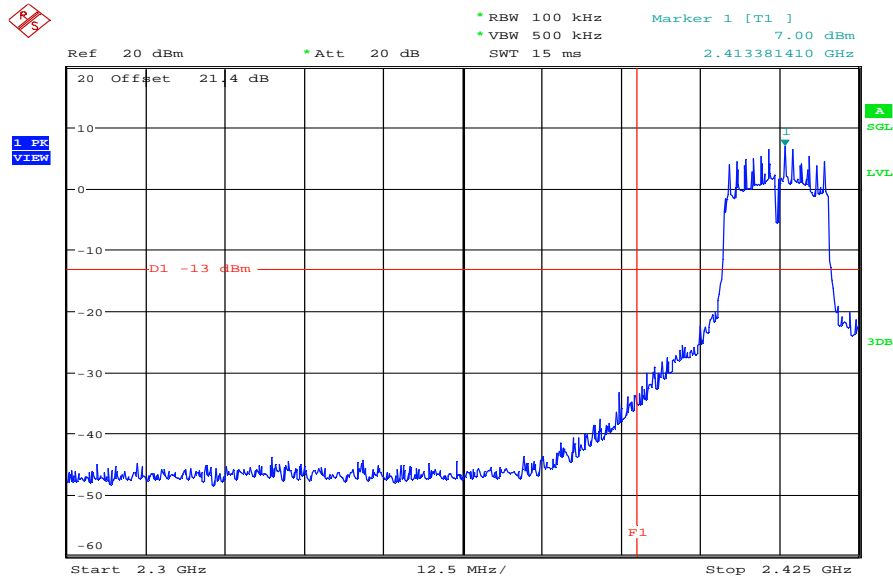

Date: 12.FEB.2011 08:54:05

**Plot 2: TX mode, upper band edge**

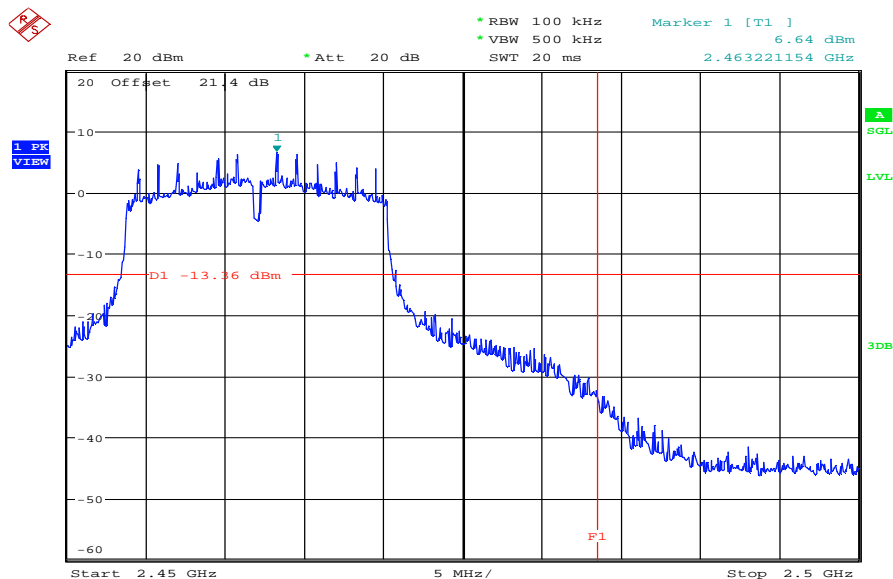

Date: 12.FEB.2011 08:59:19

**Plots: OFDM / n – mode**

**Plot 1: TX mode, lower band edge**

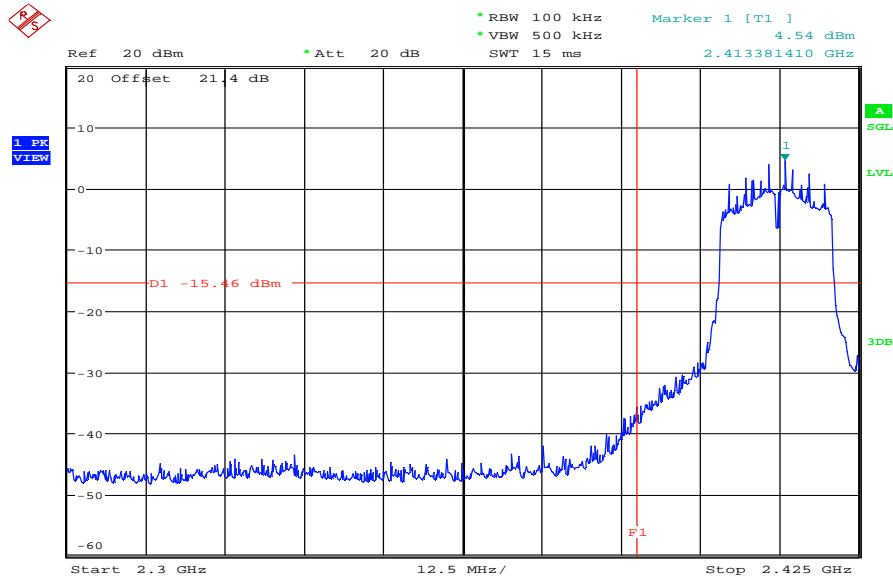

Date: 12.FEB.2011 08:55:38

**Plot 2: TX mode, upper band edge**

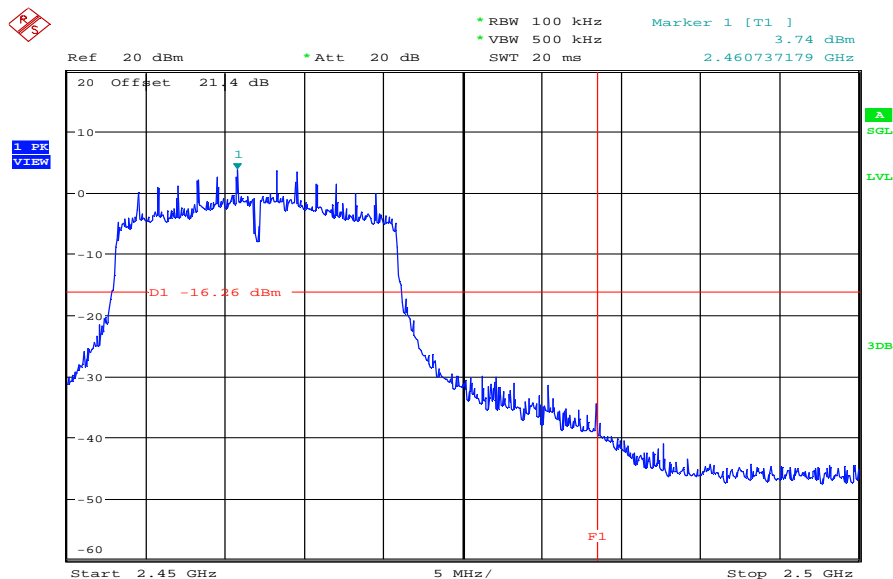

Date: 12.FEB.2011 09:00:35

## 9.8 Band edge compliance radiated

### Description:

Measurement of the radiated band edge compliance. The EUT is turned in the position that results in the maximum level at the band edge. Then a sweep over the corresponding restricted band is performed. The EUT is set to channel 1 for the lower restricted band and to channel 11 for the upper restricted band. The measurement is repeated for all modulations. Measurement distance is 3m.

### Measurement:

Measurement parameter	
Detector:	Peak
Sweep time:	Auto
Video bandwidth:	10 Hz
Resolution bandwidth:	1 MHz
Span:	Lower Band: 2300 – 2400 MHz Higher Band: 2480 – 2500 MHz
Trace-Mode:	Max Hold

### Limits:

FCC	IC
CFR Part 15.205	RSS 210, Issue 8, A 8.5
Band Edge Compliance Radiated	
<p>In any 100 kHz bandwidth outside the frequency band in which the spread spectrum or digitally modulated intentional radiator is operating, the radio frequency power that is produced by the intentional radiator shall be at least 20 dB below that in the 100 kHz bandwidth within the band that contains the highest level of the desired power, based on either an RF conducted or a radiated measurement. Attenuation below the general limits specified in Section 15.209(a) is not required. In addition, radiated emissions which fall in the restricted bands, as defined in Section 15.205(a), must also comply with the radiated emission limits specified in Section 15.209(a) (see Section 5.205(c)).</p>	
54 dBµV/m AVG	

### Results:

Scenario	Band Edge Compliance Radiated [dBµV/m]		
	DSSS (b – mode)	OFDM (g – mode)	OFDM (n – mode)
Modulation			
Lower Band Edge – Channel 1	< 54 dBµV/m (see plot 1/3)	< 54 dBµV/m (see plot 5/7)	< 54 dBµV/m (see plot 9/11)
Upper Band Edge – Channel 11	< 54 dBµV/m (see plot 2/4)	< 54 dBµV/m (see plot 6/8)	< 54 dBµV/m (see plot 10/12)
Measurement uncertainty	± 3 dB		

**Result:** The result of the measurement is passed.

**Plots: DSSS / b – mode**

**Plot 1: TX mode, lower band edge, vertical polarization**

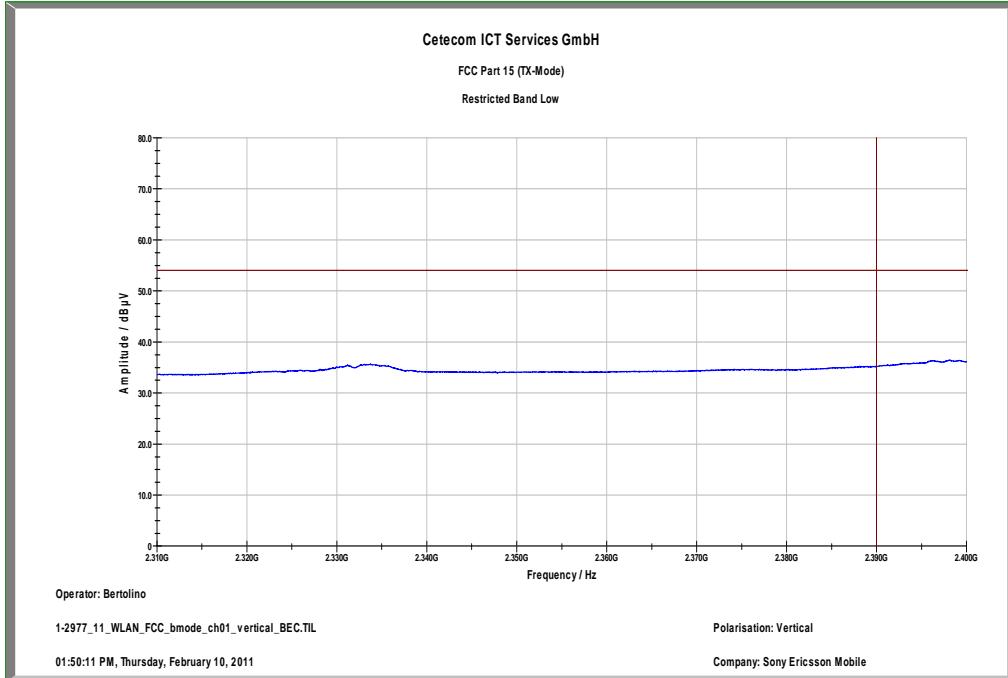

**Plot 2: TX mode, upper band edge, vertical polarization**

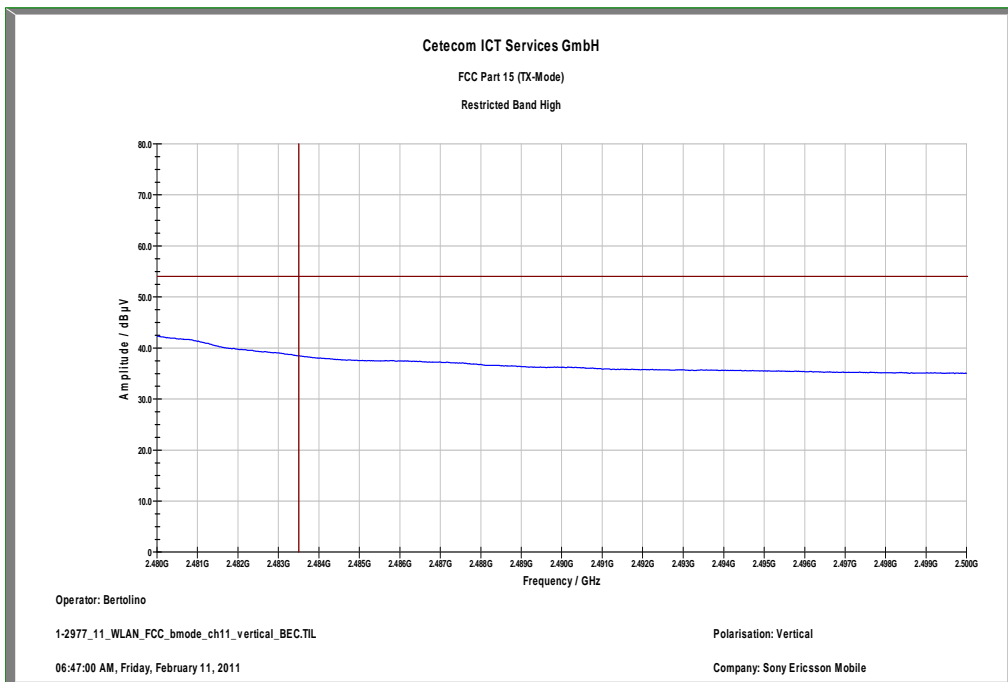

Plot 3: TX mode, lower band edge, horizontal polarization

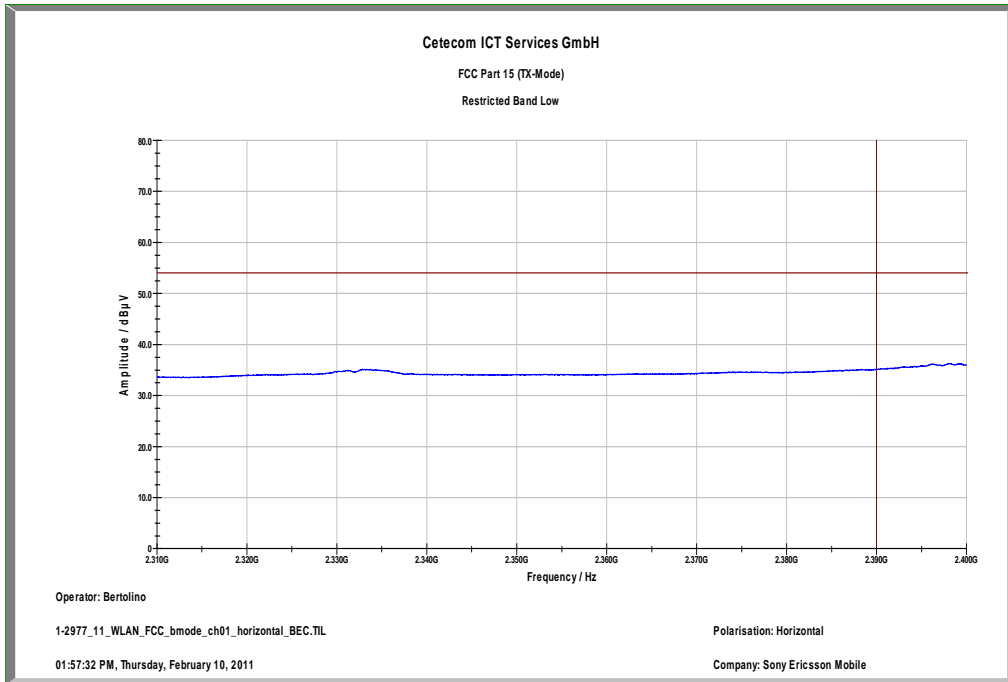

Plot 4: TX mode, upper band edge, horizontal polarization

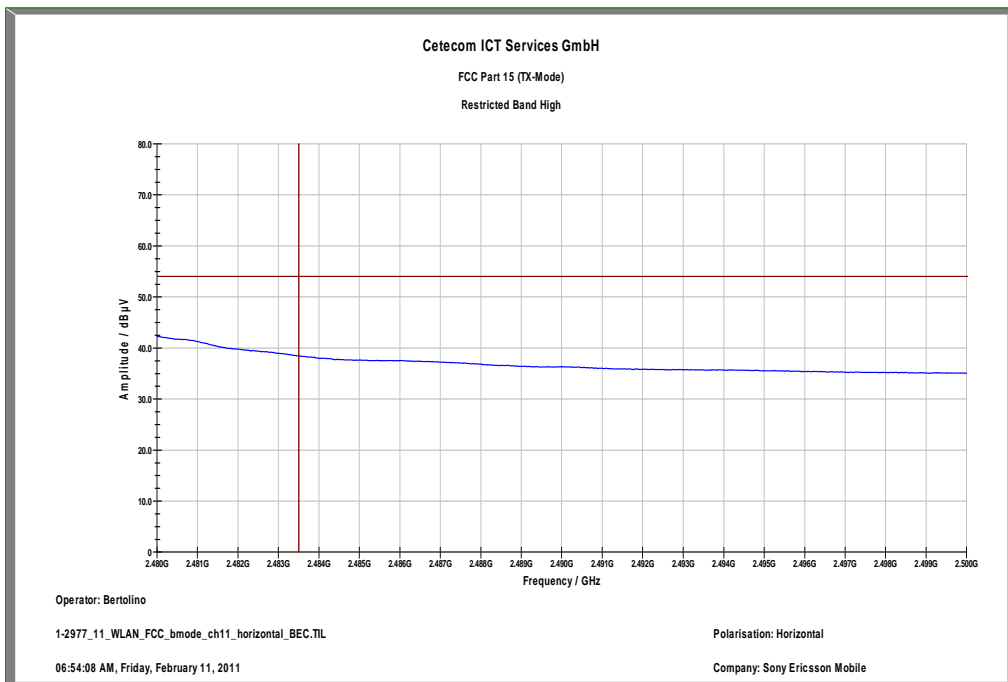

**Plots: OFDM / g – mode**

**Plot 5: TX mode, lower band edge, vertical polarization**

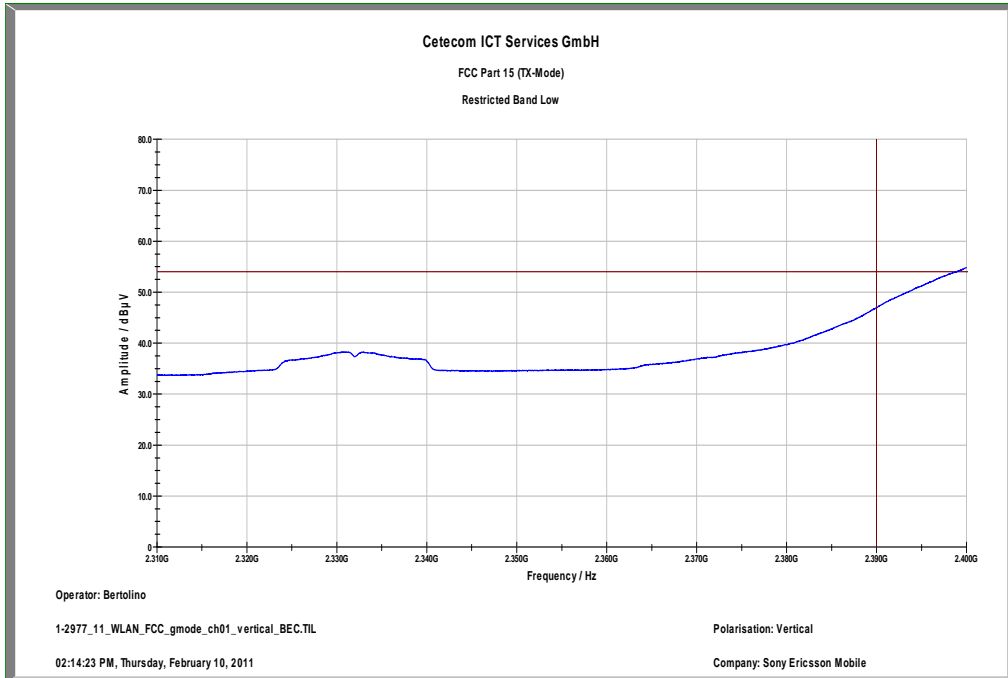

**Plot 6: TX mode, upper band edge, vertical polarization**



Plot 7: TX mode, lower band edge, horizontal polarization

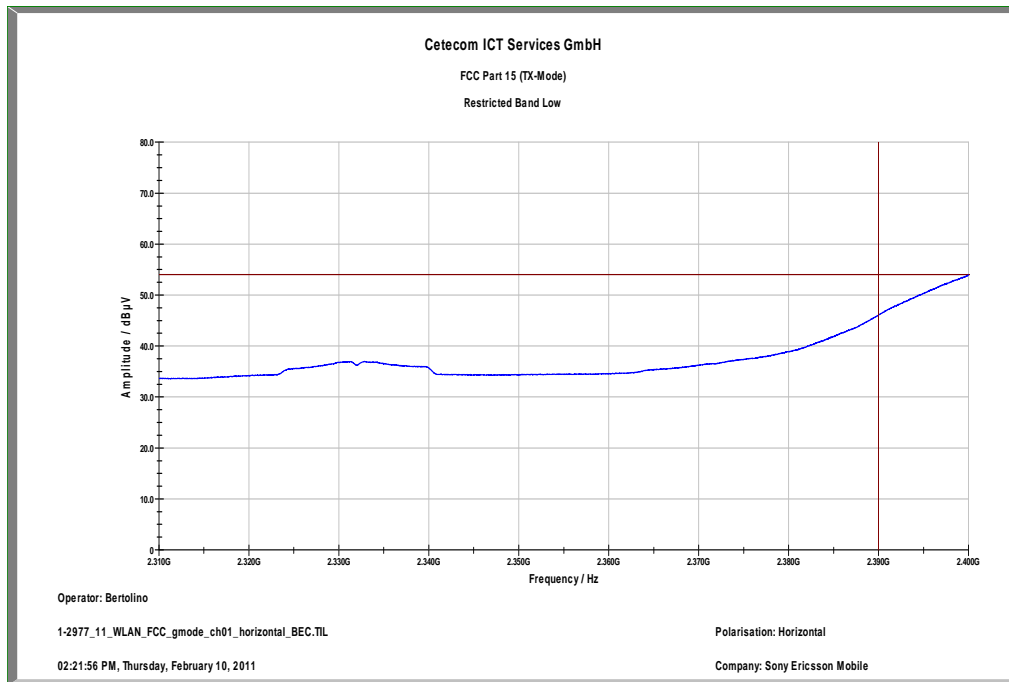

Plot 8: TX mode, upper band edge, horizontal polarization

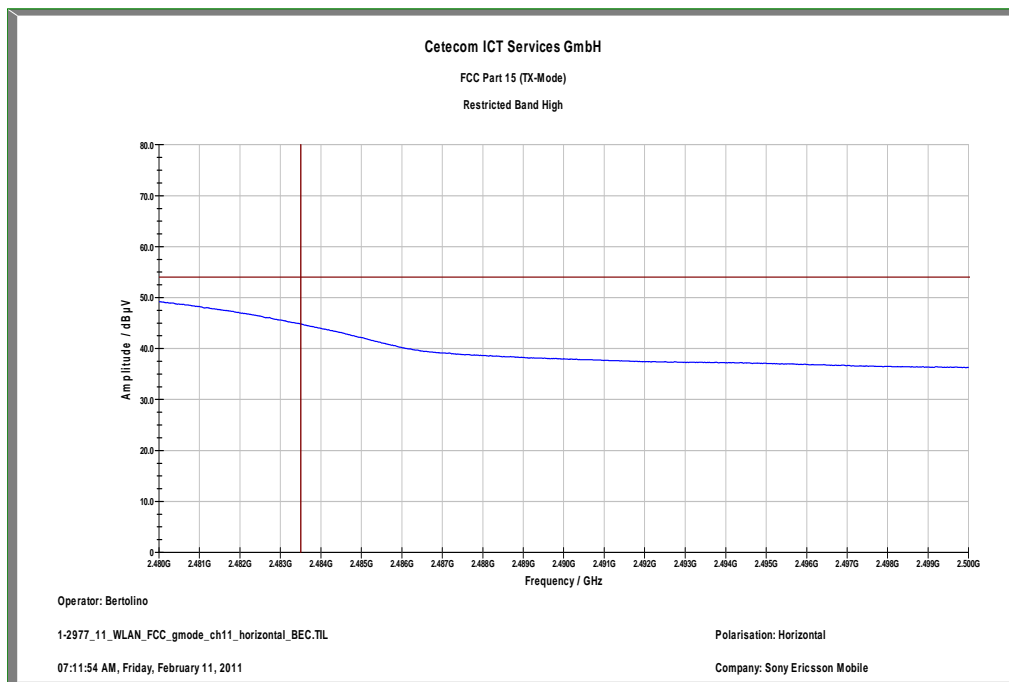



**Plots: OFDM / n – mode**

**Plot 9: TX mode, lower band edge, vertical polarization**

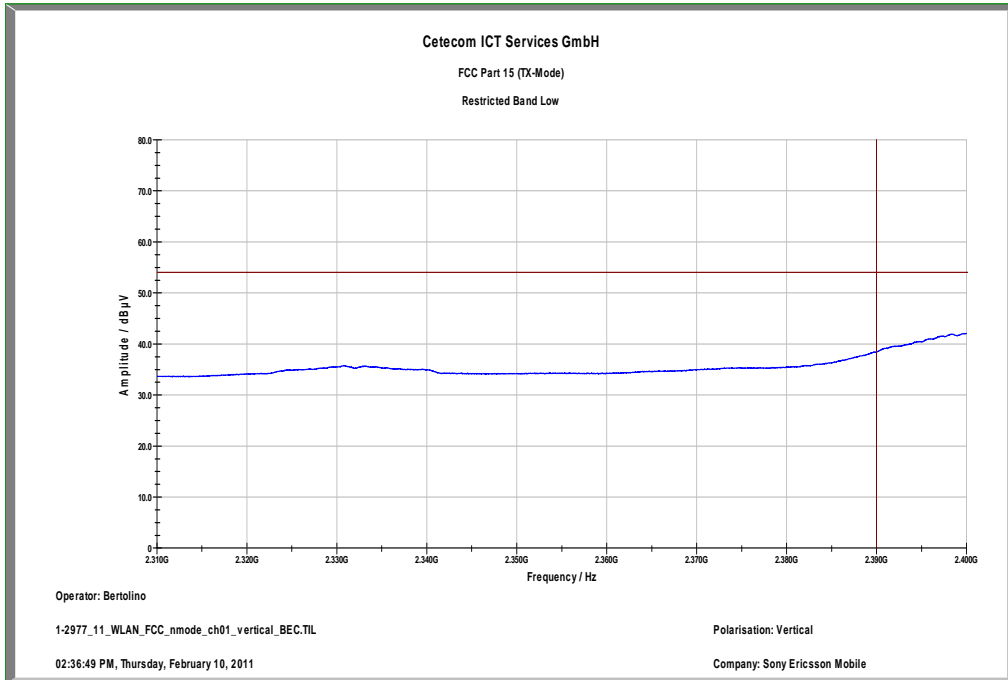

**Plot 10: TX mode, upper band edge, vertical polarization**

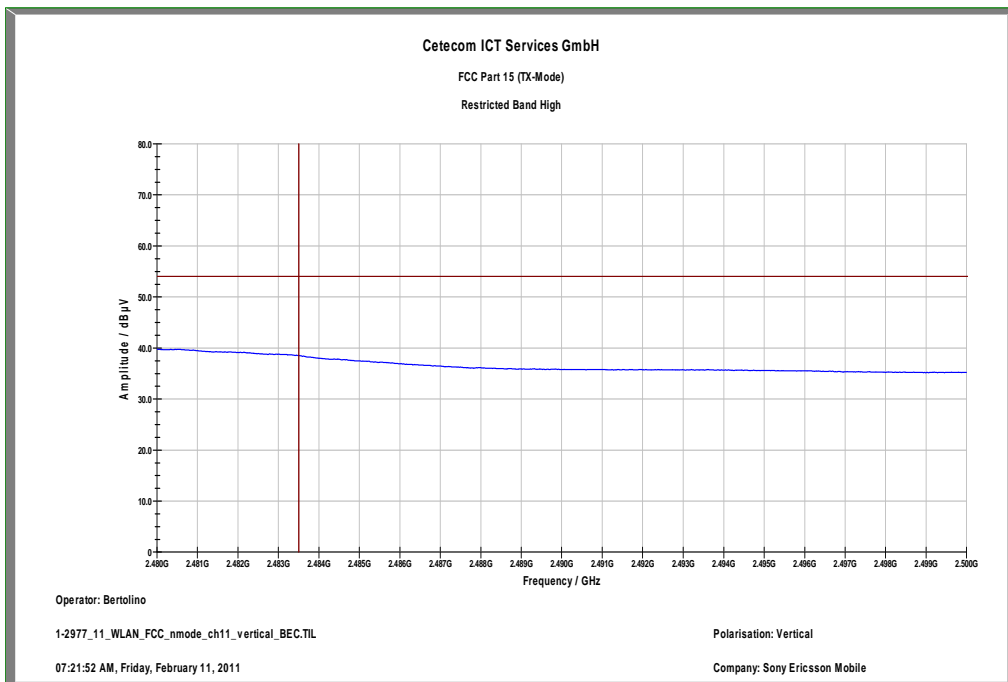

Plot 11: TX mode, lower band edge, horizontal polarization

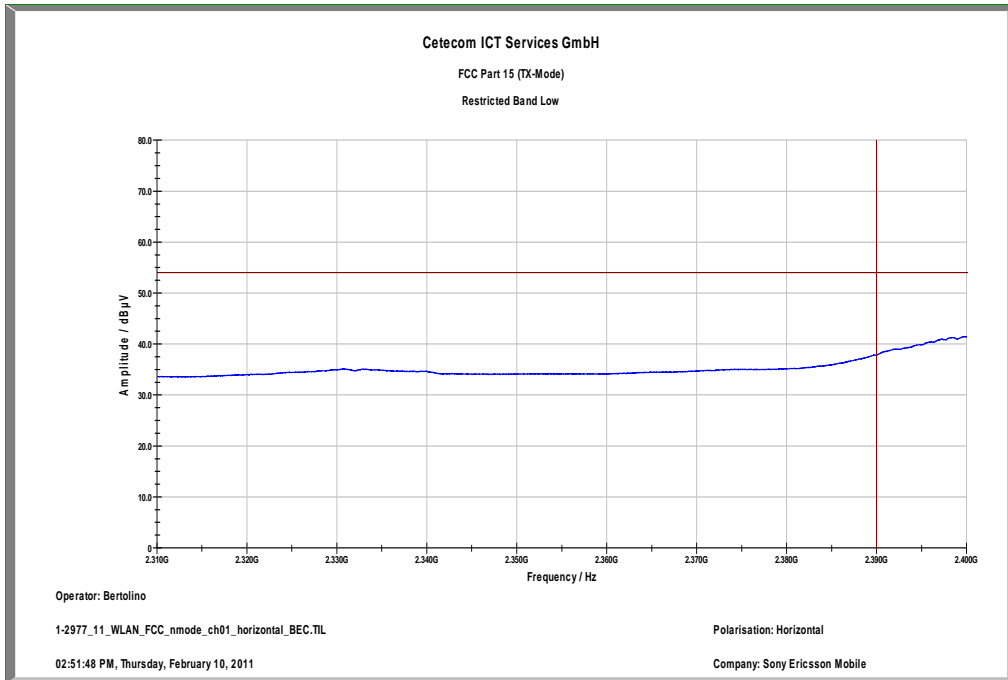

Plot 12: TX mode, upper band edge, horizontal polarization

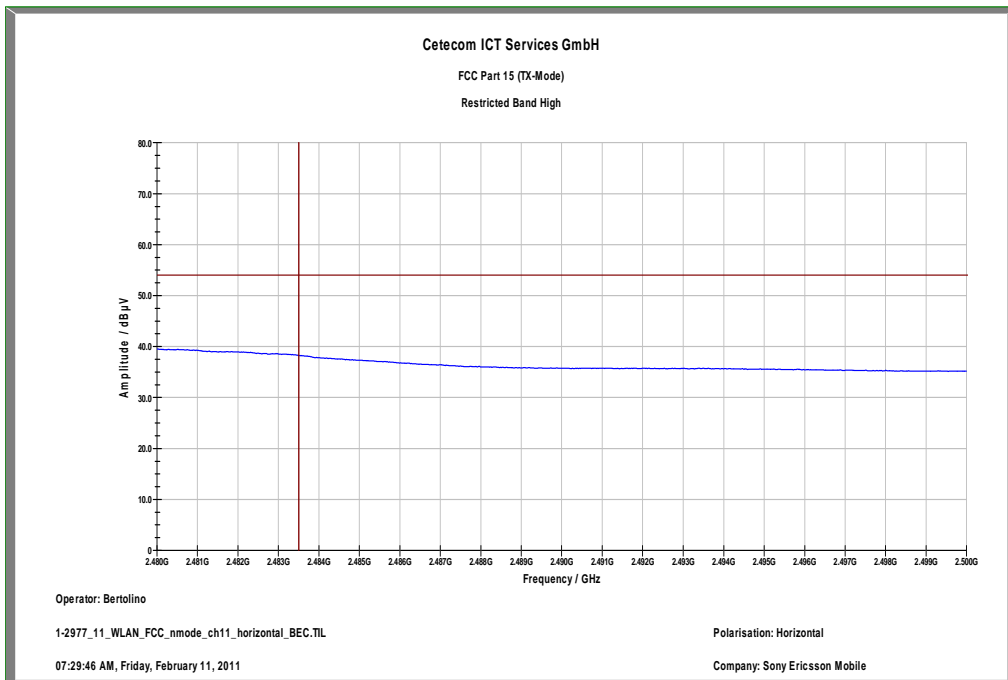

## 9.9 TX spurious emissions conducted

### Description:

Measurement of the conducted spurious emissions in transmit mode. The measurement is performed at channel 1, 6 and 11. The measurement is repeated for all modulations.

### Measurement:

Measurement parameter	
Detector:	Peak
Sweep time:	Auto
Video bandwidth:	F < 1 GHz: 500 kHz F > 1 GHz: 500 kHz
Resolution bandwidth:	F < 1 GHz: 100 kHz F > 1 GHz: 100 kHz
Span:	9 kHz to 26 GHz
Trace-Mode:	Max Hold

### Limits:

FCC	IC
CFR Part 15.247(d)	RSS 210, Issue 8, A 8.5
TX Spurious Emissions Conducted	
<p>In any 100 kHz bandwidth outside the frequency band in which the spread spectrum or digitally modulated intentional radiator is operating, the radio frequency power that is produced by the intentional radiator shall be at least 20 dB below that in the 100 kHz bandwidth within the band that contains the highest level of the desired power, based on either an RF conducted or a radiated measurement. Attenuation below the general limits specified in Section 15.209(a) is not required</p>	

**Results: DSSS / b – mode**

TX Spurious Emissions Conducted					
DSSS - mode					
f [MHz]		amplitude of emission [dBm]	limit max. allowed emission power	actual attenuation below frequency of operation [dB]	results
2412		10.22	30 dBm		Operating frequency
No critical peaks found.			-20 dBc		complies
2437		9.46	30 dBm		Operating frequency
No critical peaks found.			-20 dBc		complies
2462		9.50	30 dBm		Operating frequency
No critical peaks found.			-20 dBc		complies
Measurement uncertainty			± 3 dB		

**Result:** The result of the measurement is passed.

**Results: OFDM / g – mode**

TX Spurious Emissions Conducted					
OFDM - mode					
f [MHz]		amplitude of emission [dBm]	limit max. allowed emission power	actual attenuation below frequency of operation [dB]	results
2412		3.83	30 dBm		Operating frequency
No critical peaks found.			-20 dBc		complies
2437		5.51	30 dBm		Operating frequency
No critical peaks found.			-20 dBc		complies
2462		4.96	30 dBm		Operating frequency
No critical peaks found.			-20 dBc		complies
Measurement uncertainty			± 3 dB		

**Result:** The result of the measurement is passed.

**Results: OFDM / n – mode**

TX Spurious Emissions Conducted					
OFDM - mode					
f [MHz]		amplitude of emission [dBm]	limit max. allowed emission power	actual attenuation below frequency of operation [dB]	results
2412		4.96	30 dBm		Operating frequency
No critical peaks found.			-20 dBc		complies
2437		4.79	30 dBm		Operating frequency
No critical peaks found.			-20 dBc		complies
2462		2.96	30 dBm		Operating frequency
No critical peaks found.			-20 dBc		complies
Measurement uncertainty		± 3 dB			

**Result:** The result of the measurement is passed.

**Plots: DSSS / b – mode**

**Plot 1: TX mode, lowest channel, up to 1 GHz**

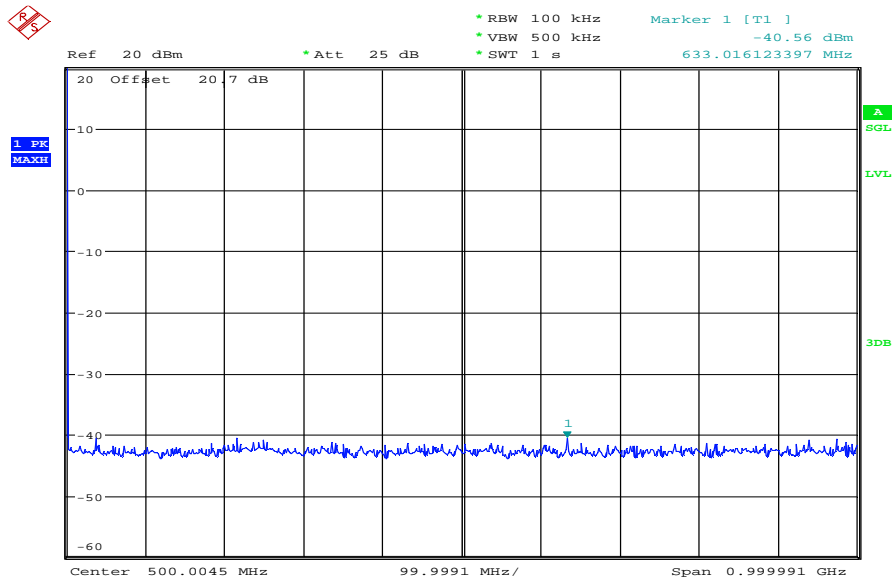

Date: 12.FEB.2011 07:18:08

The peak at the beginning of the plot is the LO from the SA.

**Plot 2: TX mode, lowest channel, 1 GHz to 12 GHz**

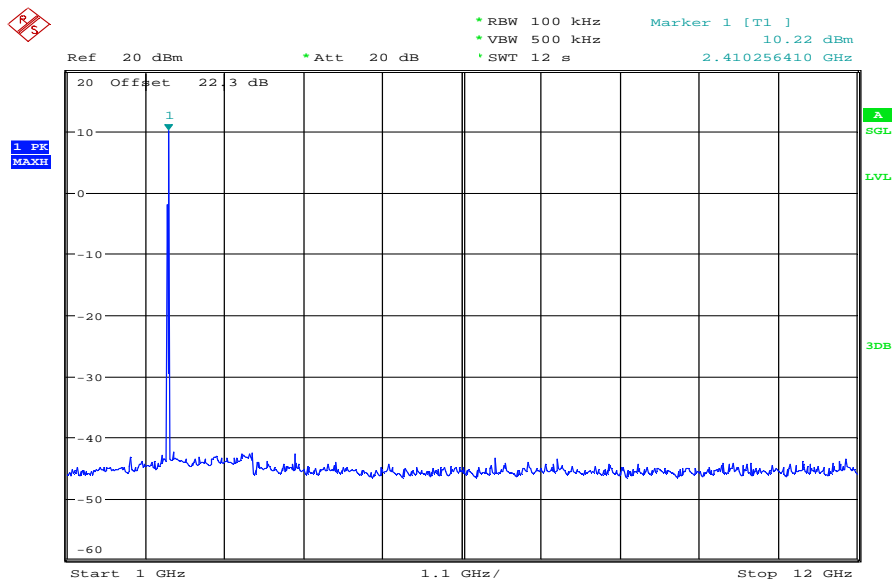

Date: 12.FEB.2011 08:07:20

**Plot 3: TX mode, lowest channel, 12 GHz to 26 GHz**

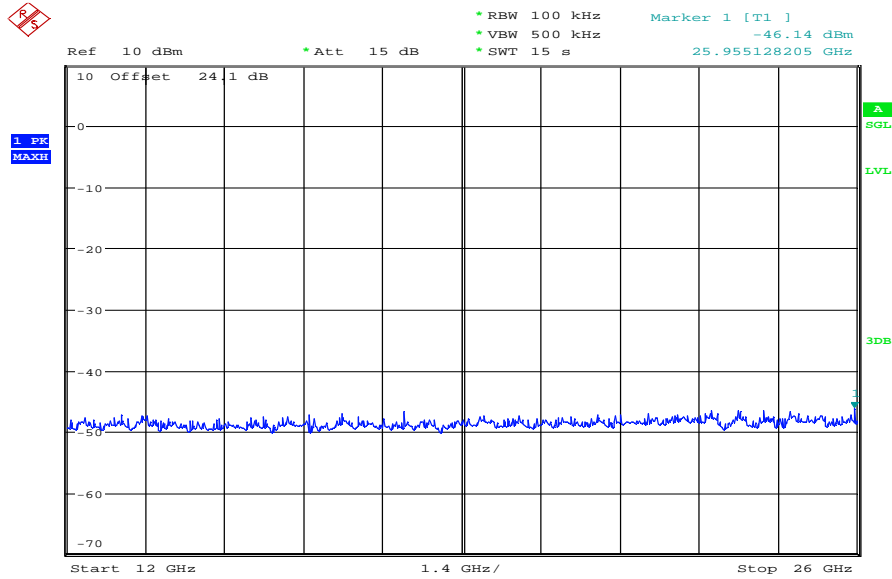

Date: 12.FEB.2011 08:24:41

**Plot 4: TX mode, middle channel, up to 1 GHz**

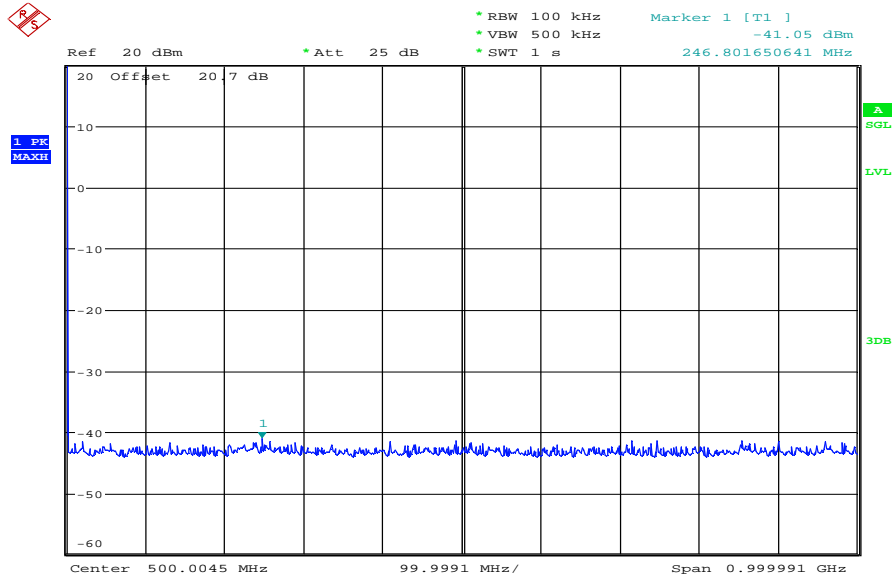

Date: 12.FEB.2011 07:19:39

The peak at the beginning of the plot is the LO from the SA.

Plot 5: TX mode, middle channel, 1 GHz to 12 GHz

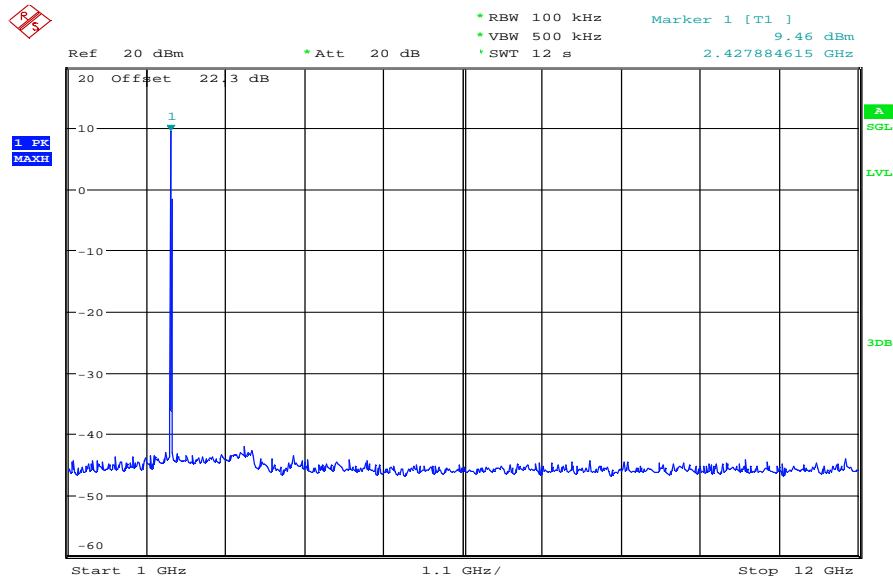

Date: 12.FEB.2011 08:09:17

Plot 6: TX mode, middle channel, 12 GHz to 26 GHz

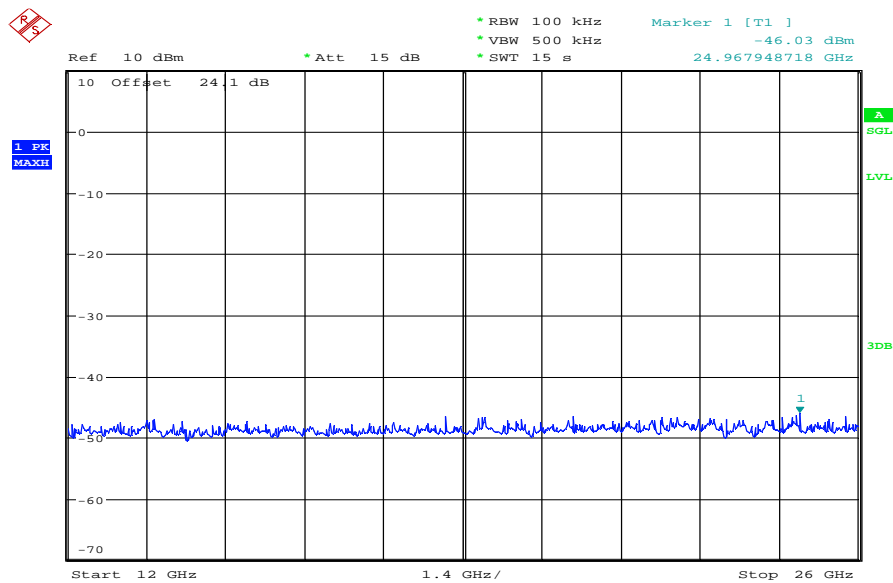

Date: 12.FEB.2011 08:25:53



**Plot 7: TX mode, highest channel, up to 1 GHz**

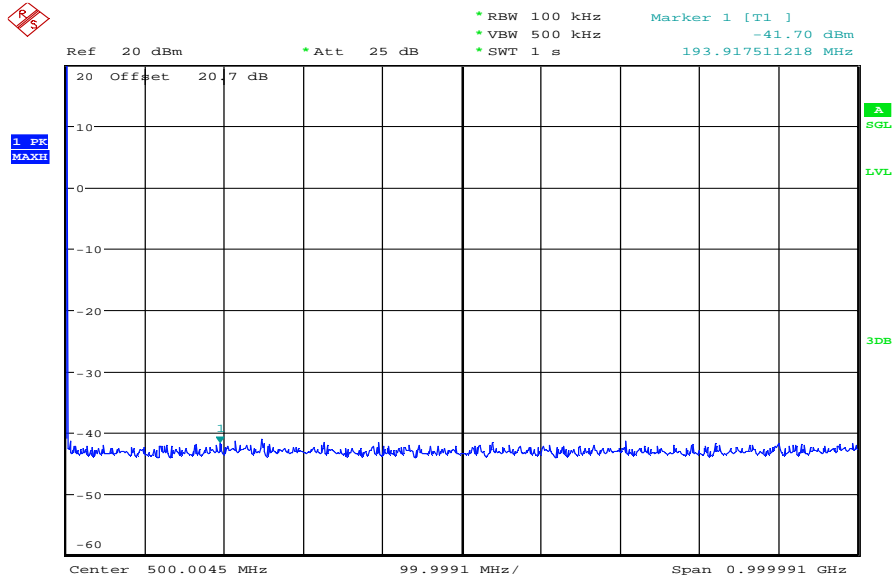

Date: 12.FEB.2011 07:21:01

The peak at the beginning of the plot is the LO from the SA.

**Plot 8: TX mode, highest channel, 1 GHz to 12 GHz**

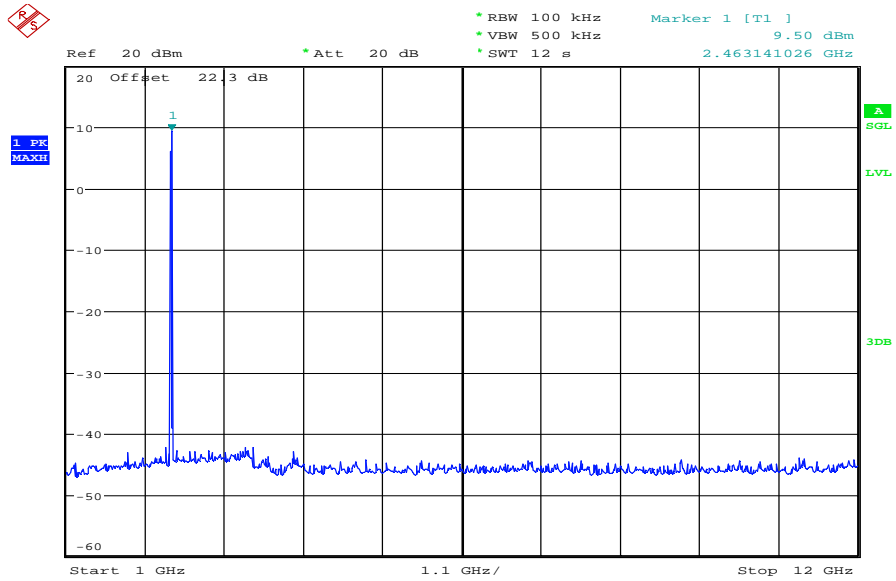

Date: 12.FEB.2011 08:10:54

Plot 9: TX mode, highest channel, 12 GHz to 26 GHz

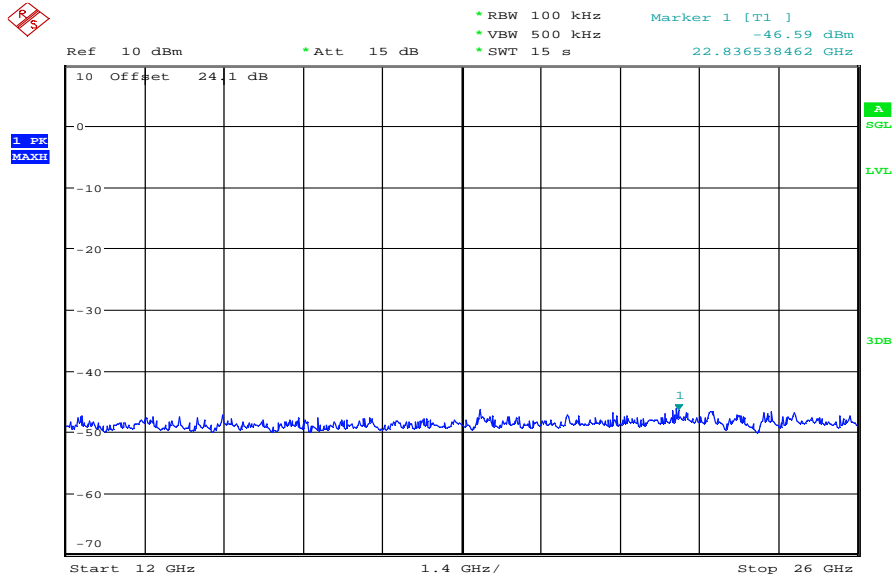

Date: 12.FEB.2011 08:27:02

**Plots: OFDM / g – mode**

**Plot 1: TX mode, lowest channel, up to 1 GHz**

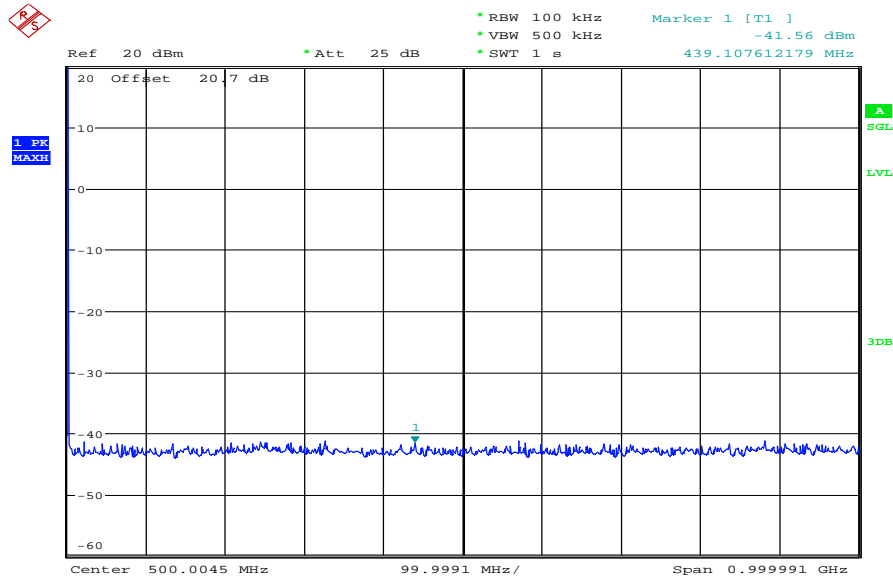

Date: 12.FEB.2011 07:22:41

The peak at the beginning of the plot is the LO from the SA.

**Plot 2: TX mode, lowest channel, 1 GHz to 12 GHz**

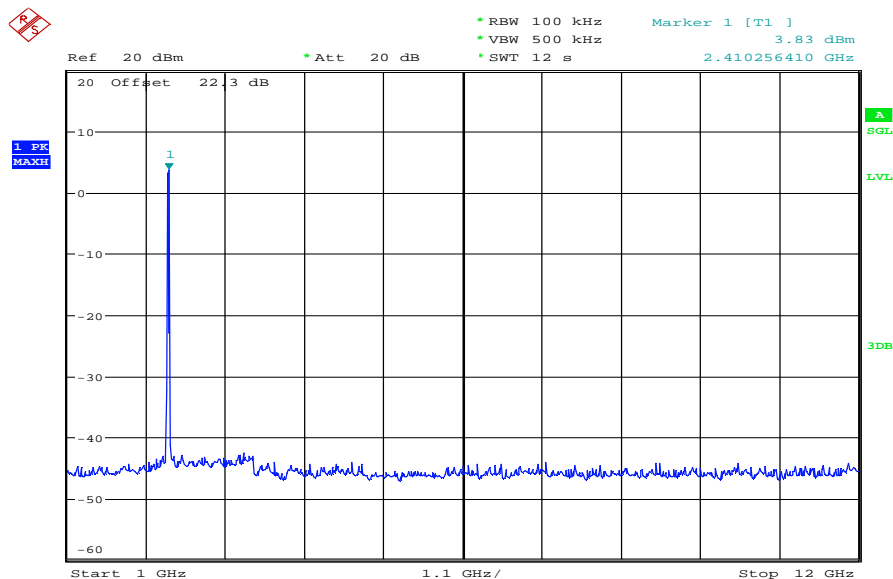

Date: 12.FEB.2011 08:12:20

Plot 3: TX mode, lowest channel, 12 GHz to 26 GHz

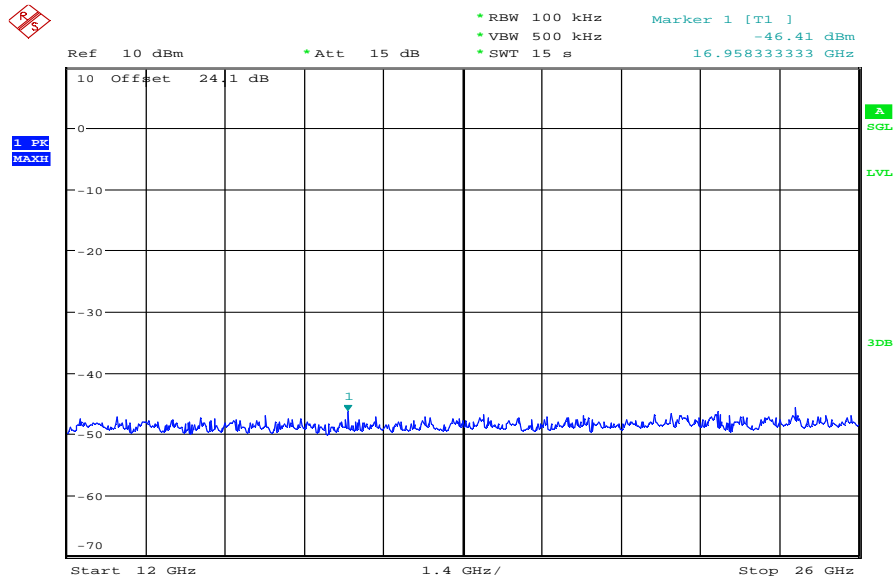

Date: 12.FEB.2011 08:28:21

Plot 4: TX mode, middle channel, up to 1 GHz

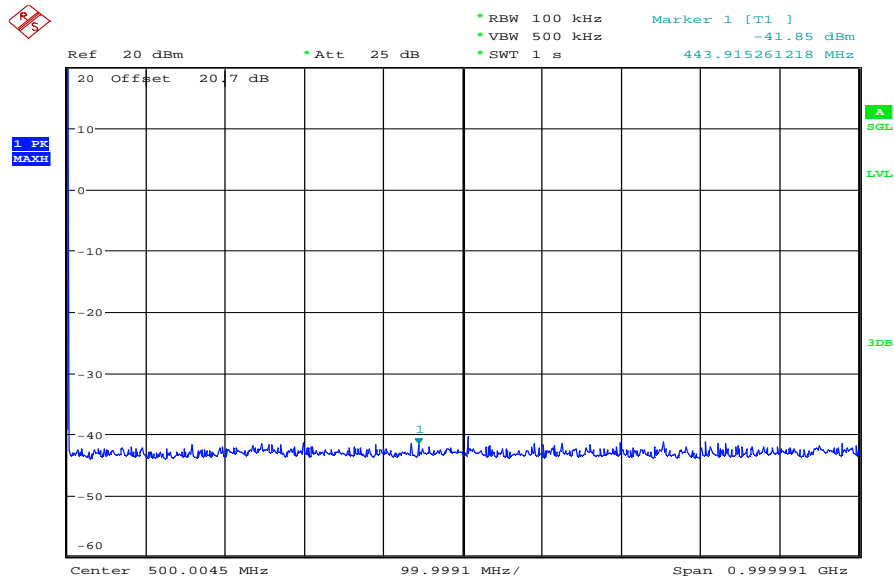

Date: 12.FEB.2011 07:24:08

The peak at the beginning of the plot is the LO from the SA.

Plot 5: TX mode, middle channel, 1 GHz to 12 GHz

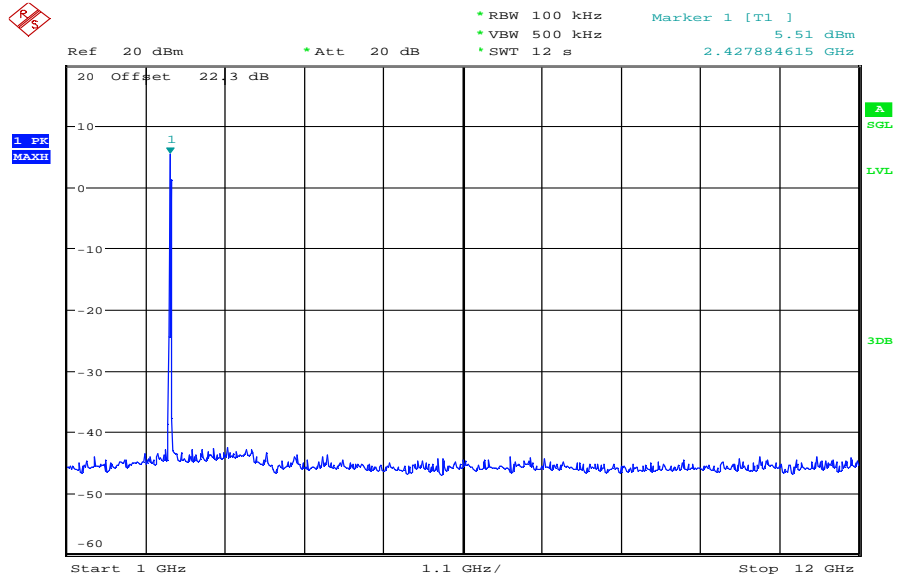

Date: 12.FEB.2011 08:13:50

Plot 6: TX mode, middle channel, 12 GHz to 26 GHz

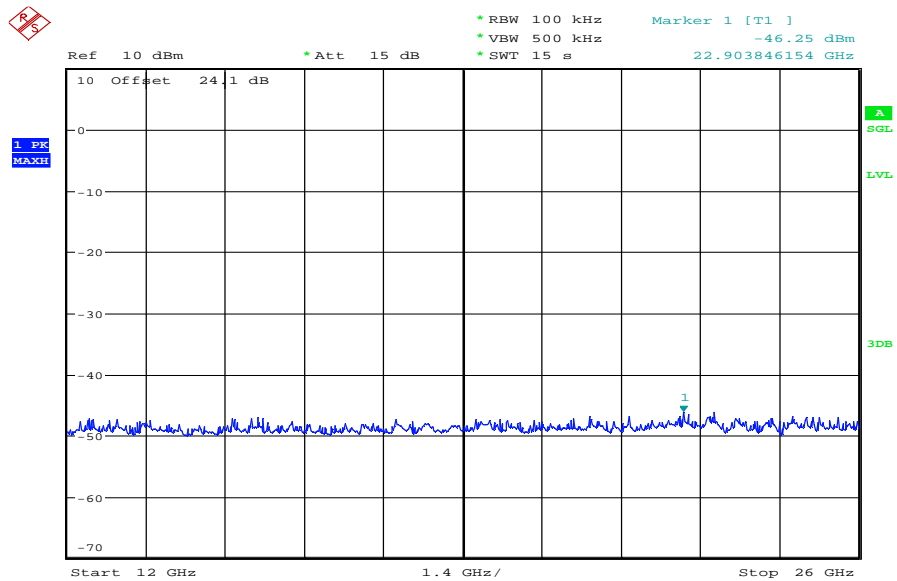

Date: 12.FEB.2011 08:29:31

**Plot 7: TX mode, highest channel, up to 1 GHz**

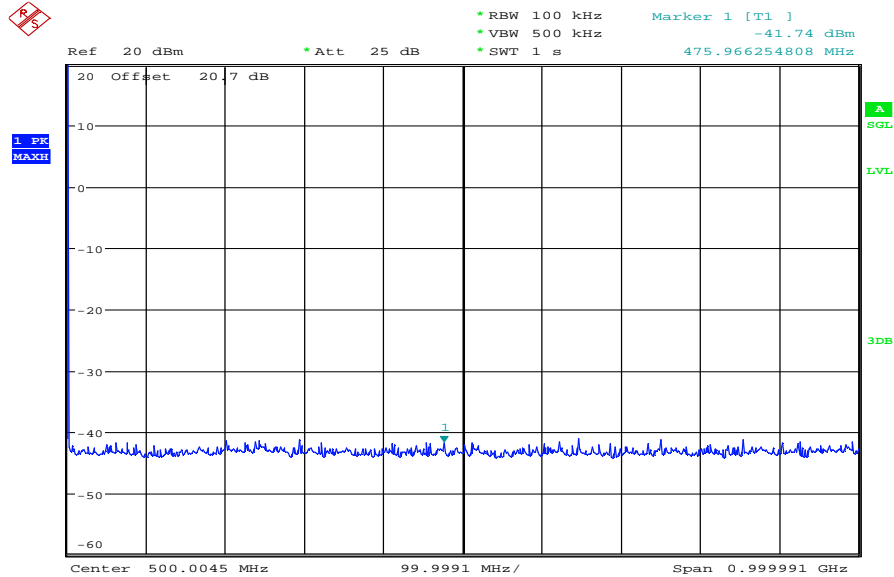

Date: 12.FEB.2011 07:25:07

The peak at the beginning of the plot is the LO from the SA.

**Plot 8: TX mode, highest channel, 1 GHz to 12 GHz**

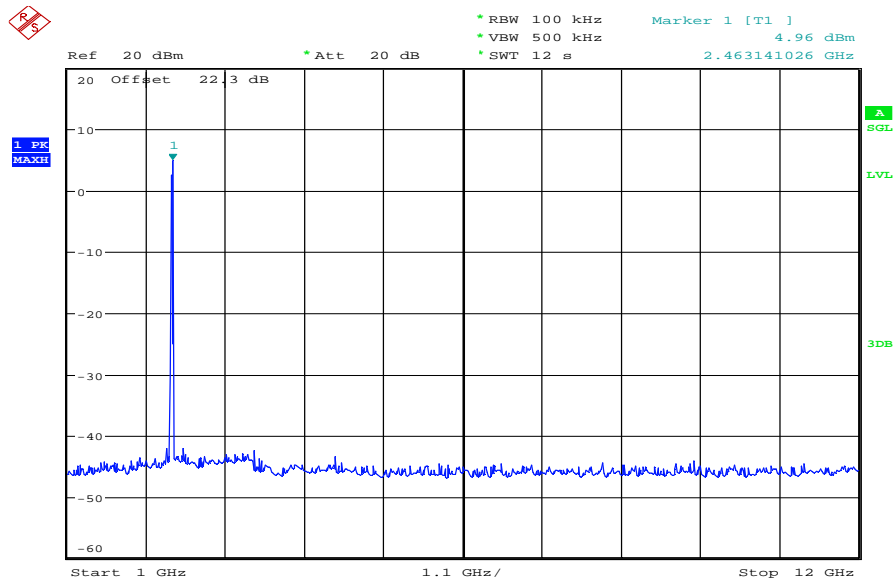

Date: 12.FEB.2011 08:15:01

Plot 9: TX mode, highest channel, 12 GHz to 26 GHz

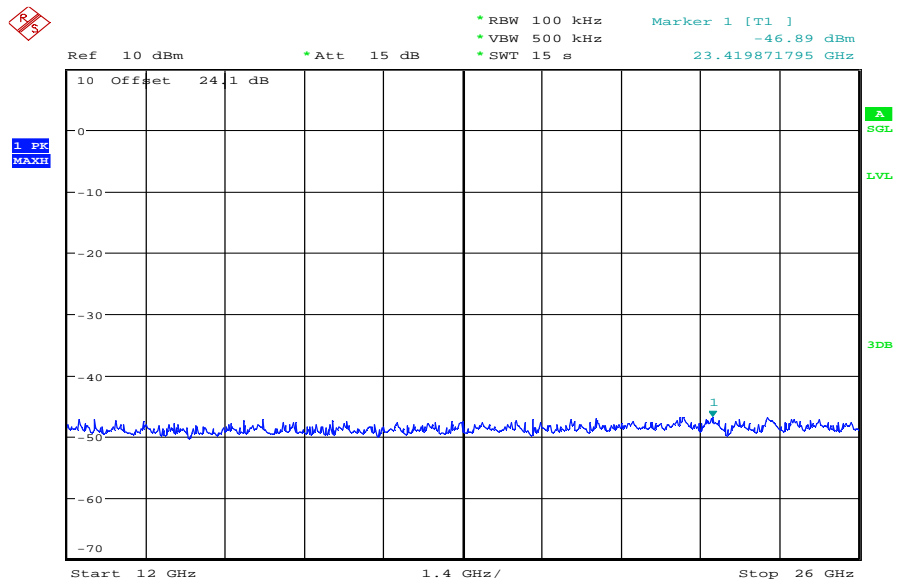

Date: 12.FEB.2011 08:30:47

**Plots: OFDM / n – mode**

**Plot 1: TX mode, lowest channel, up to 1 GHz**

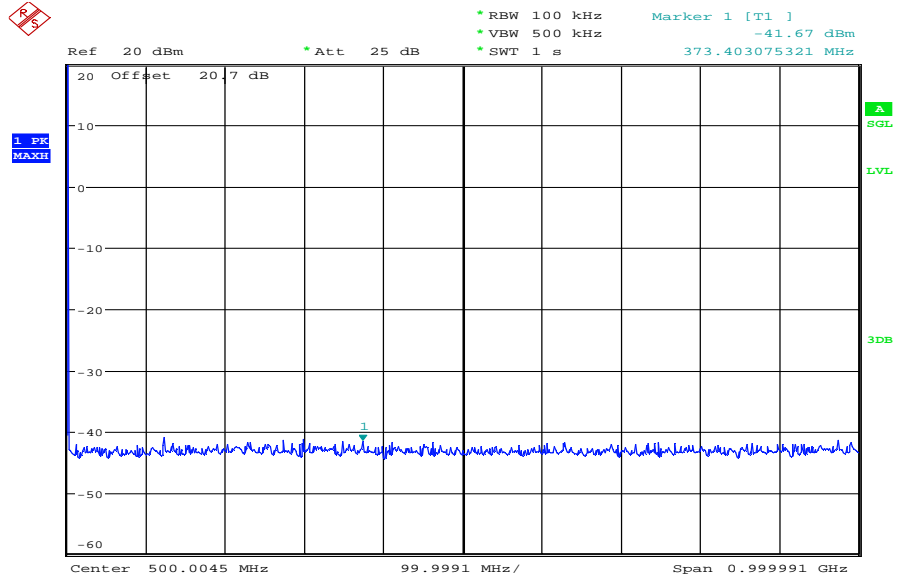

Date: 12.FEB.2011 07:26:23

The peak at the beginning of the plot is the LO from the SA.

**Plot 2: TX mode, lowest channel, 1 GHz to 12 GHz**

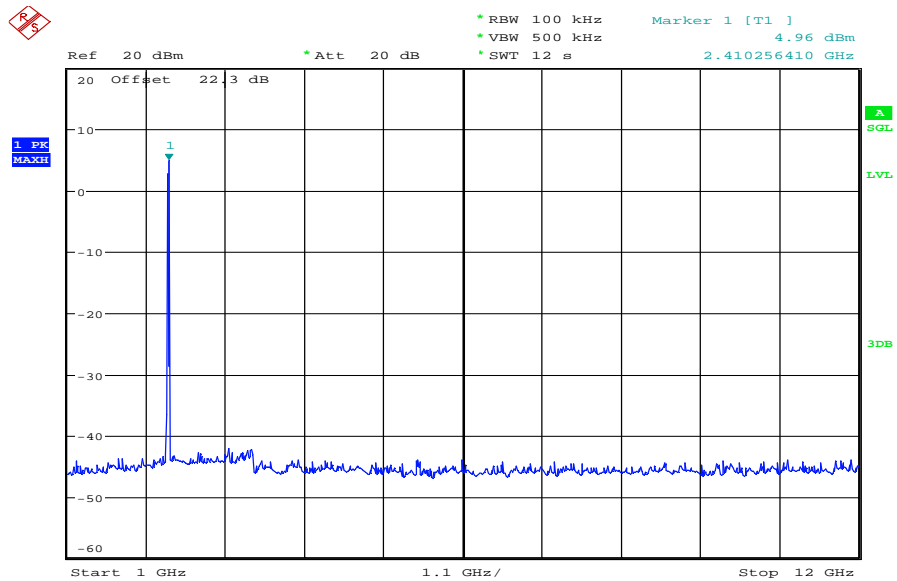

Date: 12.FEB.2011 08:16:41



Plot 3: TX mode, lowest channel, 12 GHz to 26 GHz

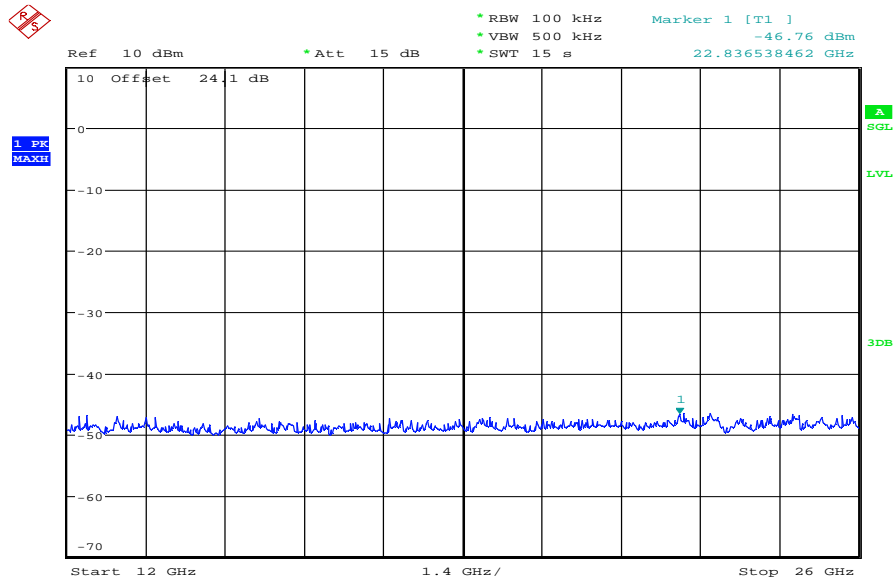

Date: 12.FEB.2011 08:32:07

Plot 4: TX mode, middle channel, up to 1 GHz

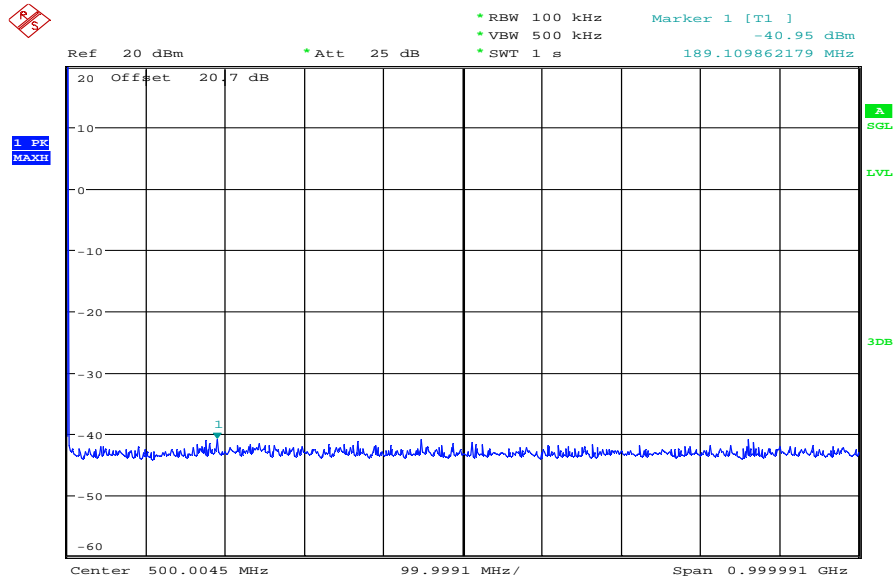

Date: 12.FEB.2011 07:27:59

The peak at the beginning of the plot is the LO from the SA.

Plot 5: TX mode, middle channel, 1 GHz to 12 GHz

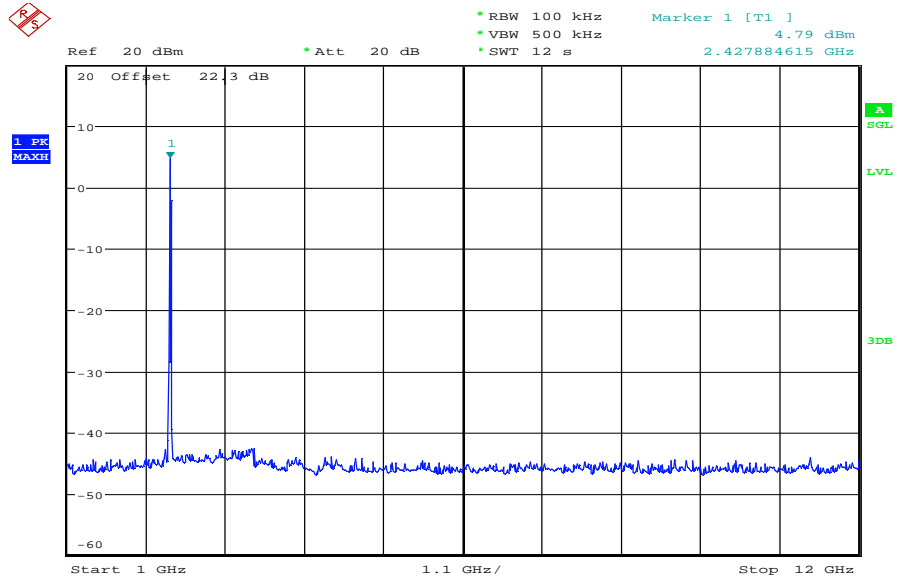

Date: 12.FEB.2011 08:17:55

Plot 6: TX mode, middle channel, 12 GHz to 26 GHz

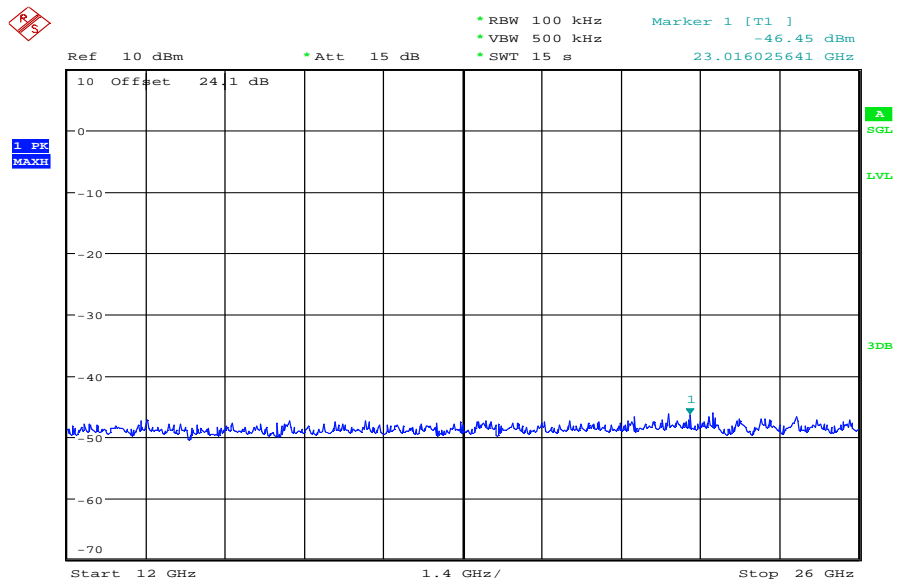

Date: 12.FEB.2011 08:33:23

Plot 7: TX mode, highest channel, up to 1 GHz

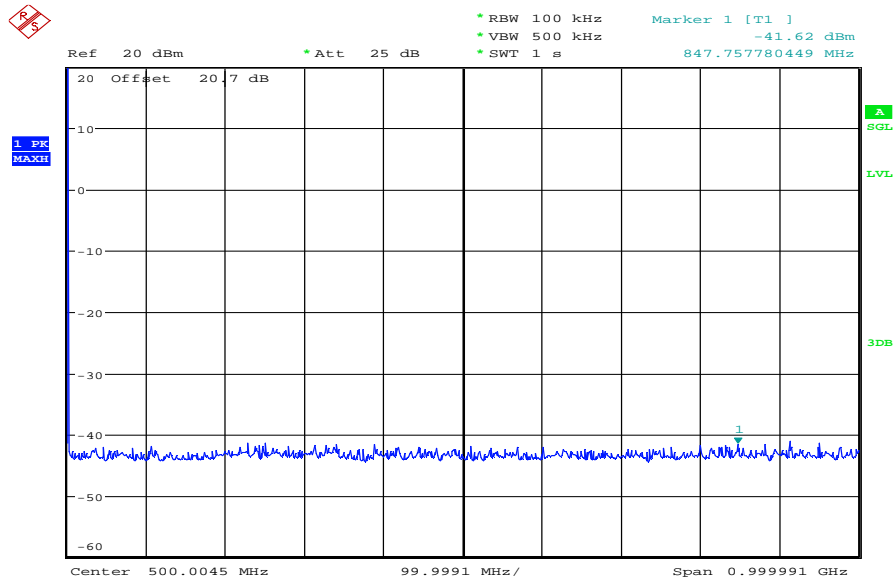

Date: 12.FEB.2011 07:28:56

The peak at the beginning of the plot is the LO from the SA.

Plot 8: TX mode, highest channel, 1 GHz to 12 GHz

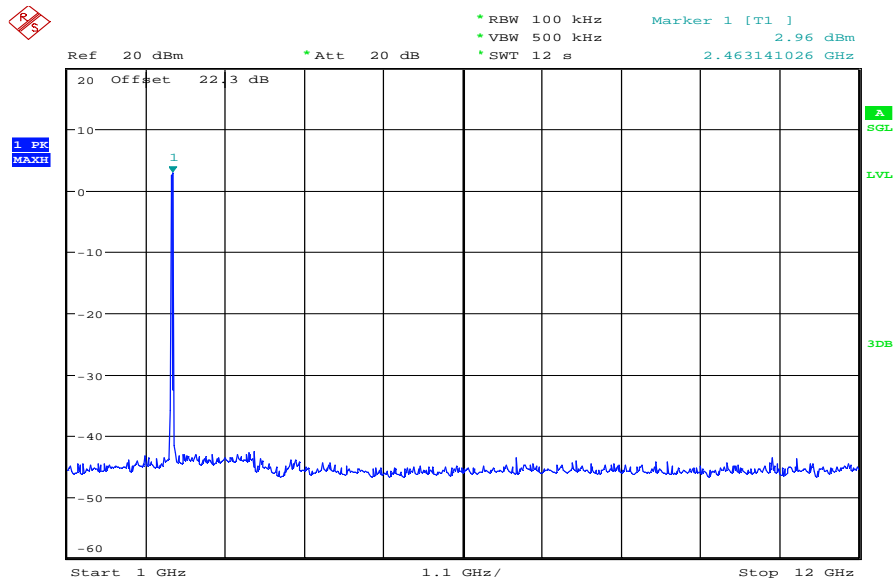

Date: 12.FEB.2011 08:19:27

Plot 9: TX mode, highest channel, 12 GHz to 26 GHz

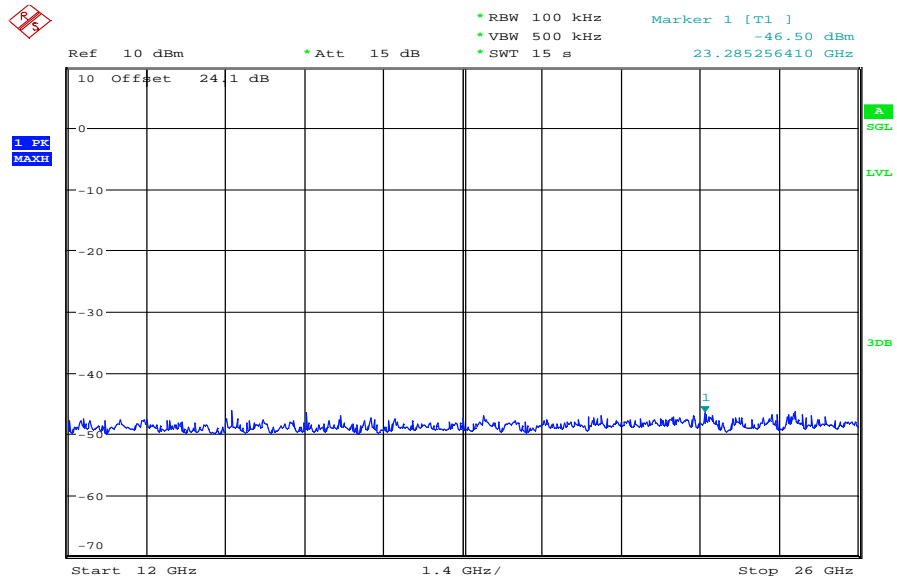

Date: 12.FEB.2011 08:34:37

## 9.10 TX spurious emissions radiated

### Description:

Measurement of the radiated spurious emissions in transmit mode. The measurement is performed at channel 1, 6 and 11. The measurement is repeated for all modulations.

### Measurement:

Measurement parameter	
Detector:	Peak / Quasi Peak
Sweep time:	Auto
Video bandwidth:	Sweep: 100 kHz Remeasurement: 10 Hz
Resolution bandwidth:	F < 1 GHz: 100 kHz F > 1 GHz: 1 MHz
Span:	30 MHz to 25 GHz
Trace-Mode:	Max Hold
Measured modulation / technology	<input checked="" type="checkbox"/> DSSS <input checked="" type="checkbox"/> OFDM (g – mode) <input checked="" type="checkbox"/> OFDM (n – mode)

The modulation with the highest output power was used to perform the transmitter spurious emissions. If spurious were detected a re-measurement was performed on the detected frequency with each modulation.

### Limits:

FCC		IC	
CFR Part 15.247(d)		RSS 210, Issue 8, A 8.5	
TX Spurious Emissions Radiated			
<p>In any 100 kHz bandwidth outside the frequency band in which the spread spectrum or digitally modulated intentional radiator is operating, the radio frequency power that is produced by the intentional radiator shall be at least 20 dB below that in the 100 kHz bandwidth within the band that contains the highest level of the desired power, based on either an RF conducted or a radiated measurement. Attenuation below the general limits specified in Section 15.209(a) is not required. In addition, radiated emissions which fall in the restricted bands, as defined in §15.205(a), must also comply with the radiated emission limits specified in §15.209(a) (see §15.205(c)).</p>			
§15.209			
Frequency (MHz)	Field Strength (dBµV/m)	Measurement distance	
30 - 88	30.0	10	
88 – 216	33.5	10	
216 – 960	36.0	10	
Above 960	54.0	3	

**Results: DSSS / b – mode**

TX Spurious Emissions Radiated [dBµV/m]								
DSSS – mode								
2412 MHz			2437 MHz			2462 MHz		
F [MHz]	Detector	Level [dBµV/m]	F [MHz]	Detector	Level [dBµV/m]	F [MHz]	Detector	Level [dBµV/m]
For emissions below 1 GHz, please take a look at the table below the 1 GHz plot.			For emissions below 1 GHz, please take a look at the table below the 1 GHz plot.			For emissions below 1 GHz, please take a look at the table below the 1 GHz plot.		
2333.2 MHz	1 MHz / 10 Hz	Vertical 37.75 Horizontal 37.62	2358.7 MHz	1 MHz / 10 Hz	Vertical 36.89 Horizontal 36.57	2305.3 MHz	1 MHz / 10 Hz	Vertical 34.23 Horizontal 32.61
4823.8 MHz	1 MHz / 10 Hz	Vertical 34.77 Horizontal 34.58	4874 MHz	1 MHz / 10 Hz	Vertical 35.31 Horizontal 35.19	2541.1 MHz	No restricted band!	
For emissions above 12.75 GHz, please take a look at the plots.			For emissions above 12.75 GHz, please take a look at the plots.			2624.2 MHz	No restricted band!	
						For emissions above 12.75 GHz, please take a look at the plots.		
Measurement uncertainty			± 3 dB					

**Result:** The result of the measurement is passed.

**Results: OFDM / g – mode**

TX Spurious Emissions Radiated [dBµV/m]								
OFDM – mode								
2412 MHz			2437 MHz			2462 MHz		
F [MHz]	Detector	Level [dBµV/m]	F [MHz]	Detector	Level [dBµV/m]	F [MHz]	Detector	Level [dBµV/m]
For emissions below 1 GHz, please take a look at the table below the 1 GHz plot.			For emissions below 1 GHz, please take a look at the table below the 1 GHz plot.			For emissions below 1 GHz, please take a look at the table below the 1 GHz plot.		
2333.2 MHz	1 MHz / 10 Hz	Vertical 34.76 Horizontal 33.72	All detected emissions are more than 20 dB below the limit!			All detected emissions are more than 20 dB below the limit!		
For emissions above 12.75 GHz, please take a look at the plots.			For emissions above 12.75 GHz, please take a look at the plots.			For emissions above 12.75 GHz, please take a look at the plots.		
Measurement uncertainty			± 3 dB					

**Result:** The result of the measurement is passed.

**Results: OFDM / n – mode**

TX Spurious Emissions Radiated [dB $\mu$ V/m]								
OFDM – mode								
2412 MHz			2437 MHz			2462 MHz		
F [MHz]	Detector	Level [dB $\mu$ V/m]	F [MHz]	Detector	Level [dB $\mu$ V/m]	F [MHz]	Detector	Level [dB $\mu$ V/m]
For emissions below 1 GHz, please take a look at the table below the 1 GHz plot.			For emissions below 1 GHz, please take a look at the table below the 1 GHz plot.			For emissions below 1 GHz, please take a look at the table below the 1 GHz plot.		
2333.2 MHz	1 MHz / 10 Hz	Vertical 36.32 Horizontal 35.91	All detected emissions are more than 20 dB below the limit!			All detected emissions are more than 20 dB below the limit!		
For emissions above 12.75 GHz, please take a look at the plots.			For emissions above 12.75 GHz, please take a look at the plots.			For emissions above 12.75 GHz, please take a look at the plots.		
Measurement uncertainty			± 3 dB					

**Result:** The result of the measurement is passed.

**Plots: DSSS / b – mode**

**Plot 1:** Lowest channel, 30 MHz to 1 GHz, vertical & horizontal polarization

**CETECOM ICT Services GmbH**

**Common Information**

EUT: AAD-3880088-BV  
 Serial Number:  
 Test Description: FCC Part 15  
 Operating Conditions: WLAN 11b, CH.1  
 Operator Name: LAN  
 Comment: AC 115V / 60 Hz

**Scan Setup: STAN\_Fin [EMI radiated]**

Hardware Setup: Electric Field (NOS)  
 Level Unit: dBµV/m

Subrange	Detectors	IF Bandwidth	Meas. Time	Receiver
30 MHz - 1,05 GHz	QuasiPeak	120 kHz	15 s	Receiver

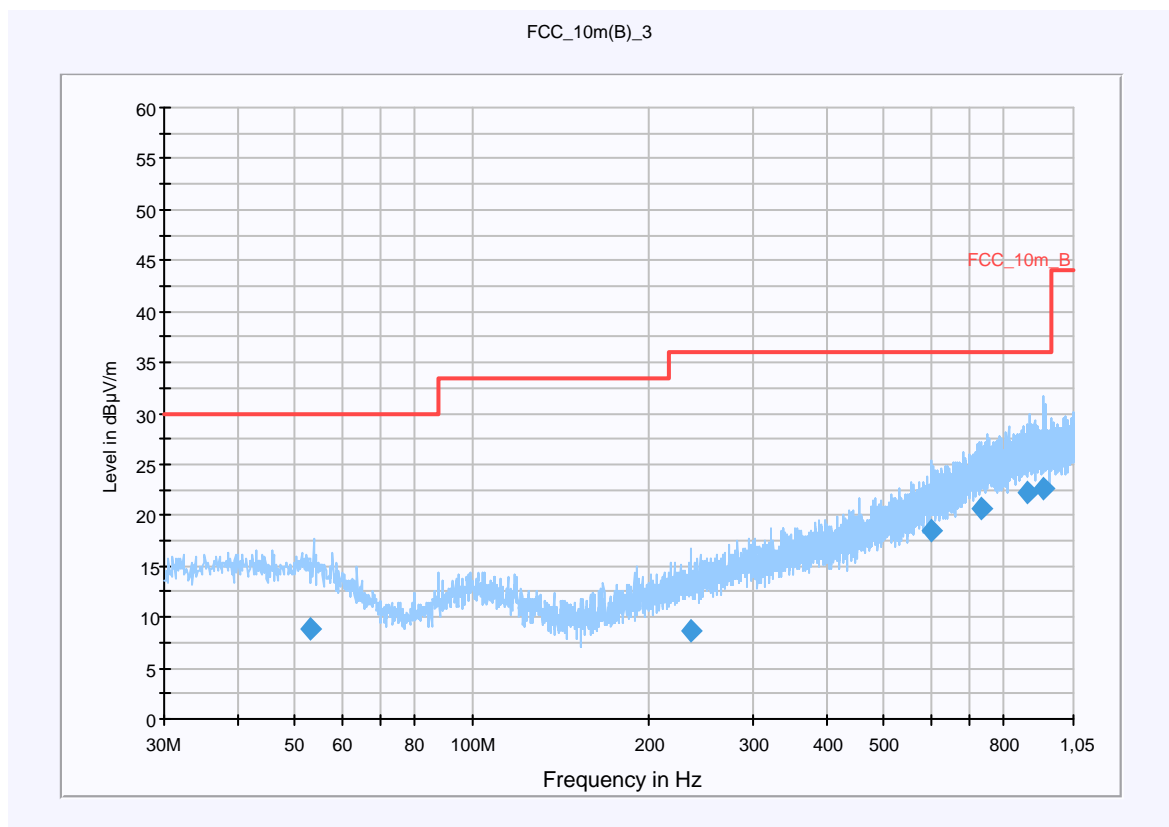

**Final Result 1**

Frequency (MHz)	QuasiPeak (dBµV/m)	Meas. Time (ms)	Bandwidth (kHz)	Antenna height (cm)	Polarity	Turntable position (deg)	Corr. (dB)	Margin (dB)	Limit (dBµV/m)	Comment
53.317800	8.8	15000.000	120.000	220.0	V	164.0	13.0	21.2	30.0	
234.756900	8.6	15000.000	120.000	220.0	V	10.0	12.9	27.4	36.0	
603.061650	18.4	15000.000	120.000	134.0	V	18.0	20.8	17.6	36.0	
731.546550	20.7	15000.000	120.000	179.0	V	123.0	23.2	15.3	36.0	
879.965850	22.3	15000.000	120.000	220.0	H	27.0	24.9	13.7	36.0	
936.920850	22.5	15000.000	120.000	220.0	V	1.0	25.3	13.5	36.0	



**Hardware Setup: EMI radiated\Electric Field (NOS) - [EMI radiated]**

Subrange 1	
Frequency Range:	30 MHz - 2 GHz
Receiver:	Receiver [ESCI 3] @ GPIB0 (ADR 20), SN 100083/003, FW 4.32
Signal Path:	without Notch FW 1.0
Antenna:	VULB 9163 SN 9163-295, FW --- Correction Table (vertical): VULP6113 Correction Table (horizontal): VULP6113 Correction Table: Cable_EN_1GHz (1005)
Antenna Tower:	Tower [EMCO 2090 Antenna Tower] @ GPIB0 (ADR 8), FW REV 3.12
Turntable:	Turntable [EMCO Turntable] @ GPIB0 (ADR 9), FW REV 3.12

EMC 32 Version 8.10.00

**Plot 2:** Lowest channel, 1 GHz to 12.75 GHz, vertical polarization

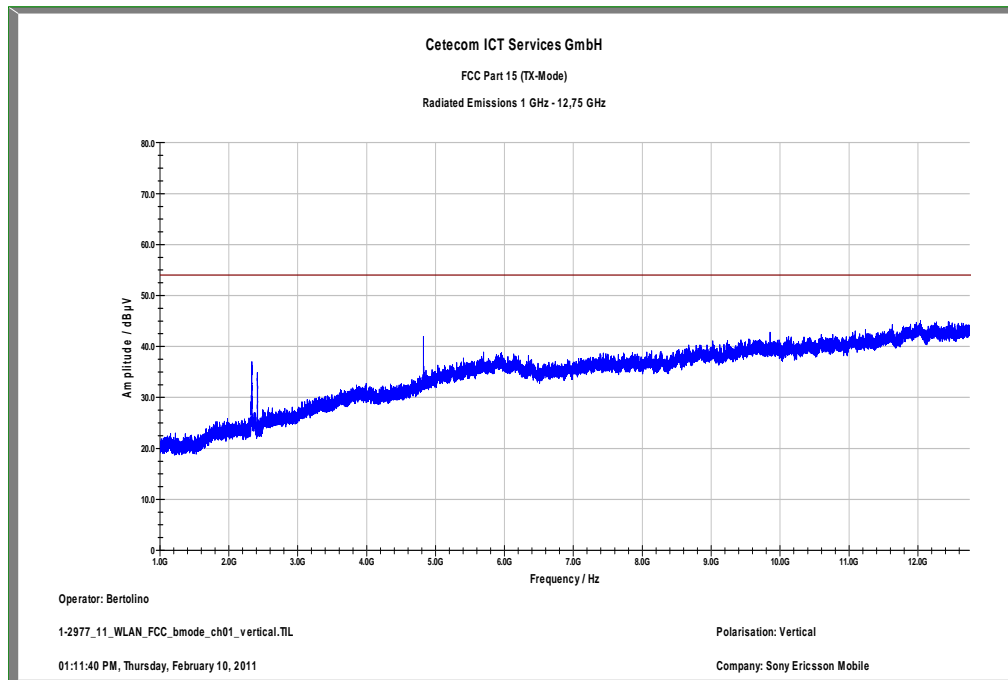

The carrier signal is notched with a 2.4 GHz band rejection filter.

**Plot 3:** Lowest channel, 1 GHz to 12.75 GHz, horizontal polarization

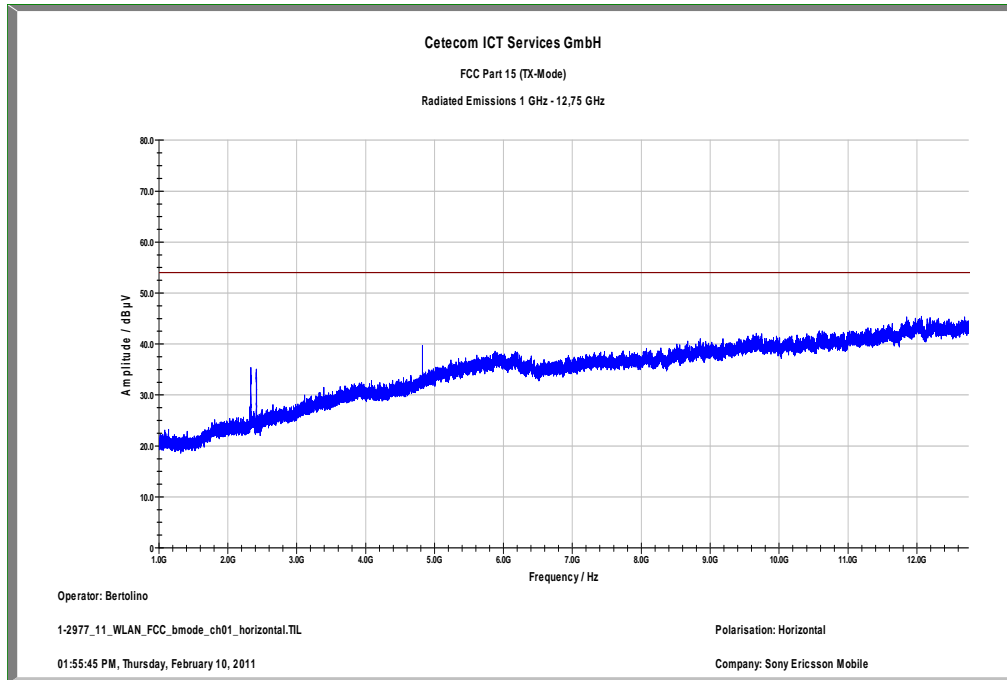

The carrier signal is notched with a 2.4 GHz band rejection filter.

**Plot 4:** Lowest channel, 12.75 GHz to 18 GHz, vertical & horizontal polarization

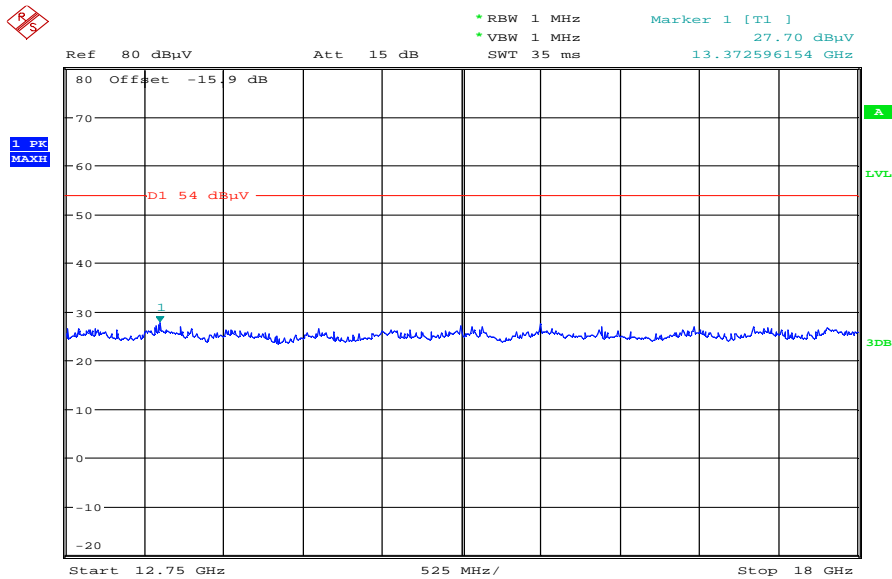

Date: 11.FEB.2011 09:17:43

Plot 5: Lowest channel, 18 GHz to 26 GHz, vertical & horizontal polarization

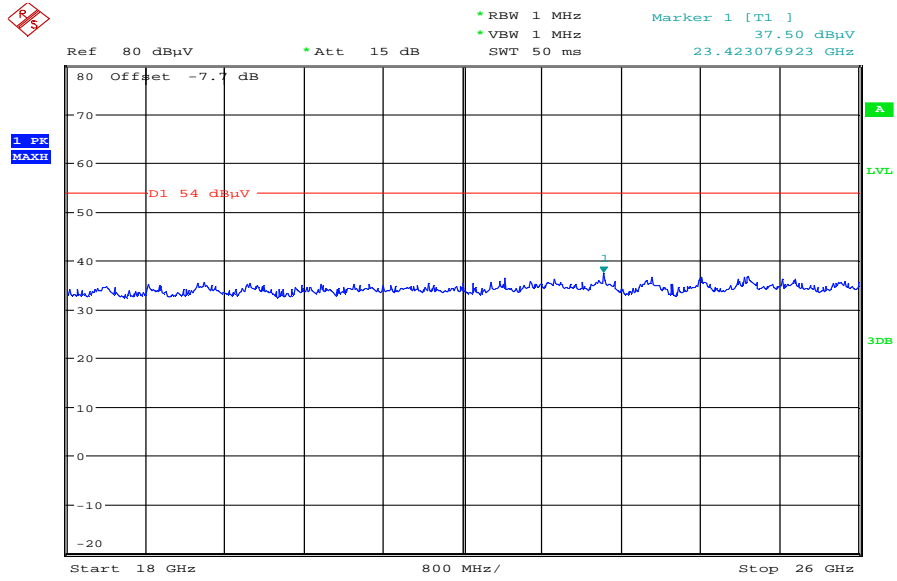

Date: 11.FEB.2011 09:46:41

**Plot 6:** Middle channel, 30 MHz to 1 GHz, vertical & horizontal polarization

**CETECOM ICT Services GmbH**

**Common Information**

EUT: AAD-3880088-BV  
 Serial Number:  
 Test Description: FCC Part 15  
 Operating Conditions: WLAN 11b, CH.6  
 Operator Name: LAN  
 Comment: AC 115V / 60 Hz

**Scan Setup: STAN\_Fin [EMI radiated]**

Hardware Setup: Electric Field (NOS)  
 Level Unit: dBµV/m

Subrange	Detectors	IF Bandwidth	Meas. Time	Receiver
30 MHz - 1,05 GHz	QuasiPeak	120 kHz	15 s	Receiver

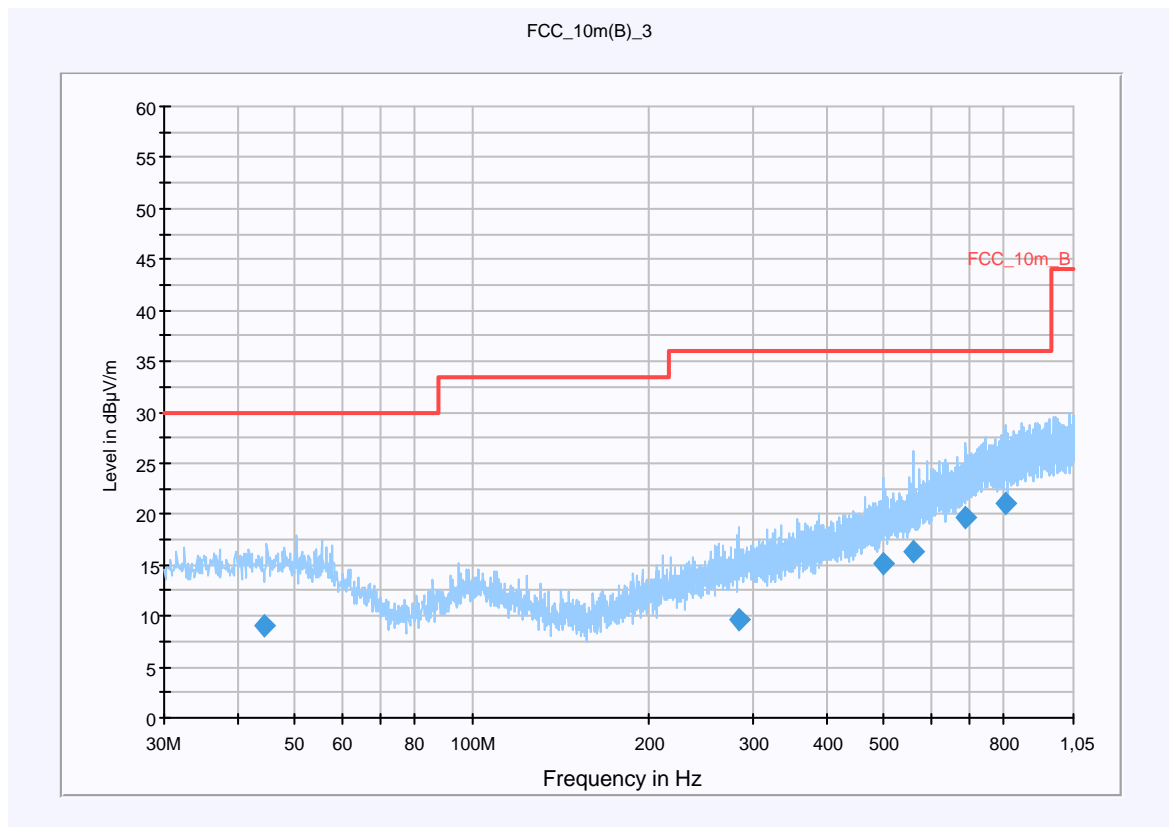

**Final Result 1**

Frequency (MHz)	QuasiPeak (dBµV/m)	Meas. Time (ms)	Bandwidth (kHz)	Antenna height (cm)	Polarity	Turntable position (deg)	Corr. (dB)	Margin (dB)	Limit (dBµV/m)	Comment
44.383350	9.0	15000.000	120.000	220.0	V	309.0	13.3	21.0	30.0	
282.917700	9.7	15000.000	120.000	105.0	V	0.0	14.1	26.3	36.0	
499.539450	15.1	15000.000	120.000	117.0	H	105.0	18.7	20.9	36.0	
562.954650	16.4	15000.000	120.000	120.0	H	53.0	19.7	19.6	36.0	
689.234700	19.6	15000.000	120.000	220.0	H	135.0	22.2	16.4	36.0	
804.114300	21.1	15000.000	120.000	202.0	V	2.0	23.9	14.9	36.0	

**Hardware Setup: EMI radiated\Electric Field (NOS) - [EMI radiated]**

Subrange 1	
Frequency Range:	30 MHz - 2 GHz
Receiver:	Receiver [ESCI 3] @ GPIB0 (ADR 20), SN 100083/003, FW 4.32
Signal Path:	without Notch FW 1.0
Antenna:	VULB 9163 SN 9163-295, FW --- Correction Table (vertical): VULP6113 Correction Table (horizontal): VULP6113 Correction Table: Cable_EN_1GHz (1005)
Antenna Tower:	Tower [EMCO 2090 Antenna Tower] @ GPIB0 (ADR 8), FW REV 3.12
Turntable:	Turntable [EMCO Turntable] @ GPIB0 (ADR 9), FW REV 3.12

EMC 32 Version 8.10.00

**Plot 7:** Middle channel, 1 GHz to 12.75 GHz, vertical polarization

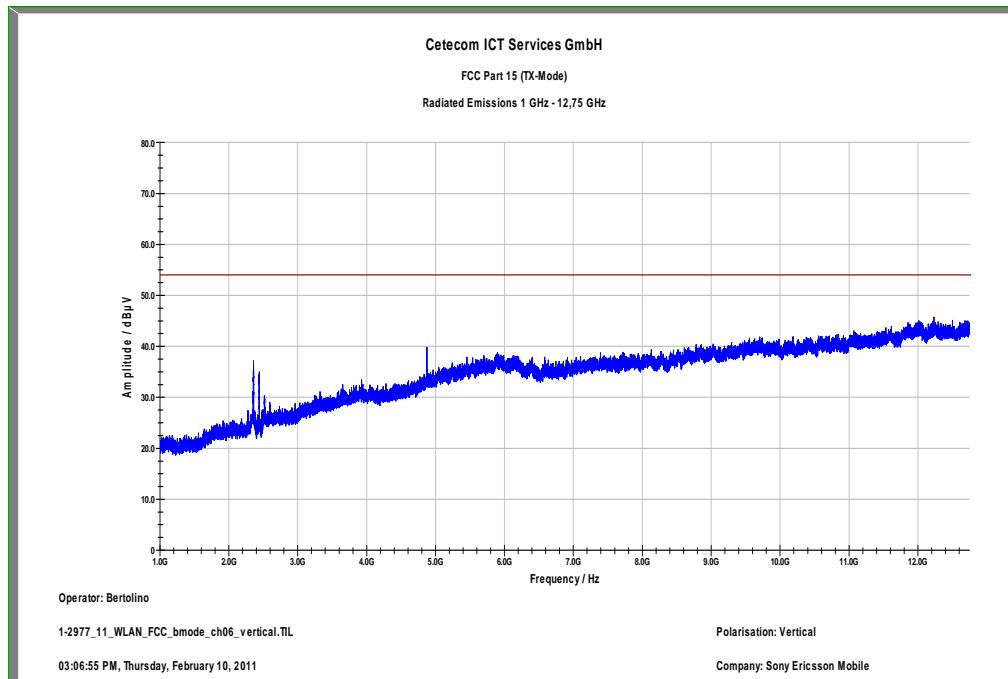

The carrier signal is notched with a 2.4 GHz band rejection filter.

**Plot 8:** Middle channel, 1 GHz to 12.75 GHz, horizontal polarization

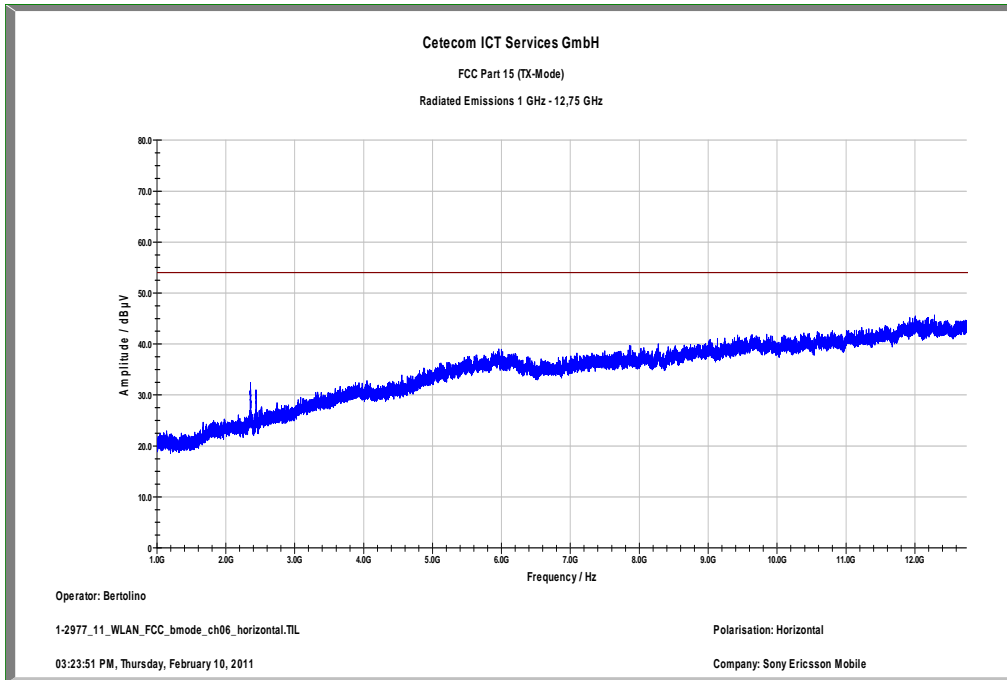

The carrier signal is notched with a 2.4 GHz band rejection filter.

**Plot 9:** Middle channel, 12.75 GHz to 18 GHz, vertical & horizontal polarization

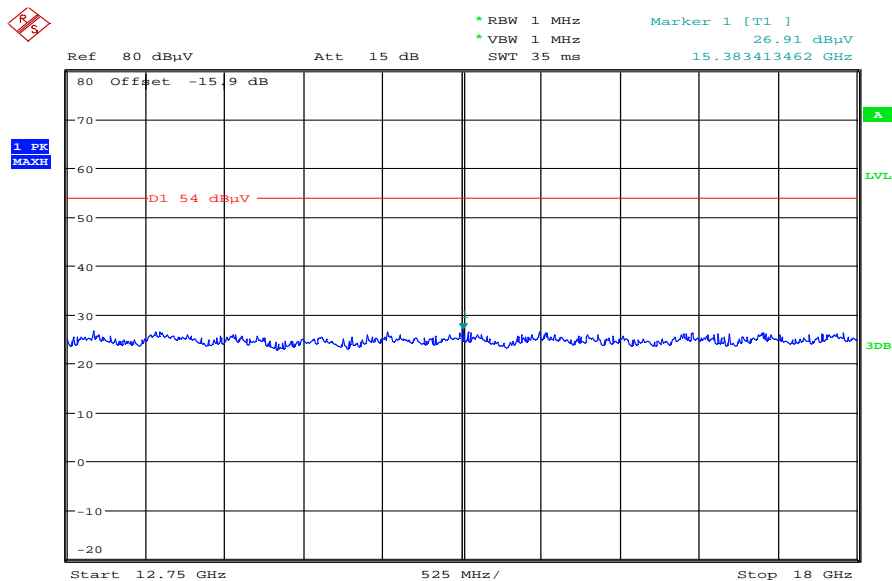

Date: 11.FEB.2011 09:18:49

Plot 10: Middle channel, 18 GHz to 26 GHz, vertical & horizontal polarization

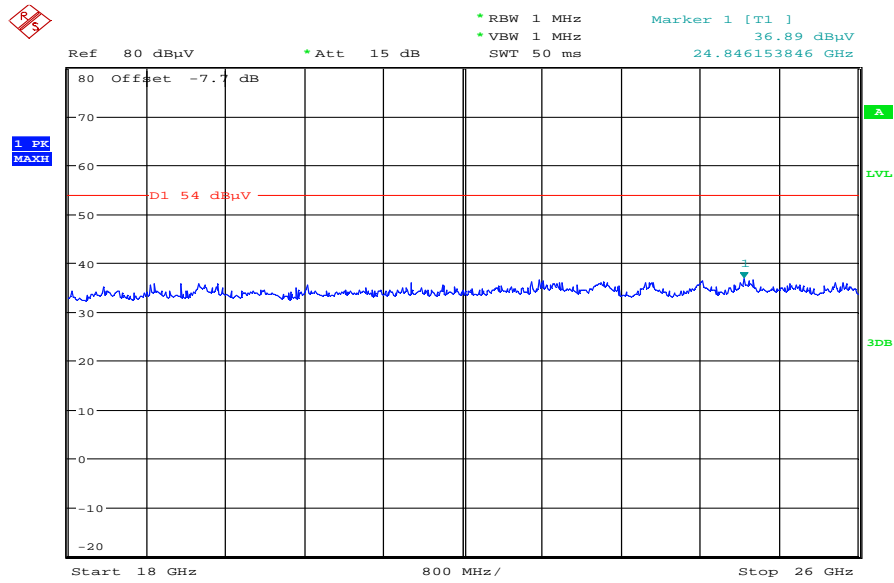

Date: 11.FEB.2011 09:47:48

Plot 11: Highest channel, 30 MHz to 1 GHz, vertical & horizontal polarization

**CETECOM ICT Services GmbH**

**Common Information**

EUT: AAD-3880088-BV  
 Serial Number:  
 Test Description: FCC Part 15  
 Operating Conditions: WLAN 11b, CH.11  
 Operator Name: LAN  
 Comment: AC 115V / 60 Hz

**Scan Setup: STAN\_Fin [EMI radiated]**

Hardware Setup: Electric Field (NOS)  
 Level Unit: dBµV/m  
**Subrange**                      **Detectors**                      **IF Bandwidth**                      **Meas. Time**                      **Receiver**  
 30 MHz - 1,05 GHz              QuasiPeak                      120 kHz                      15 s                      Receiver

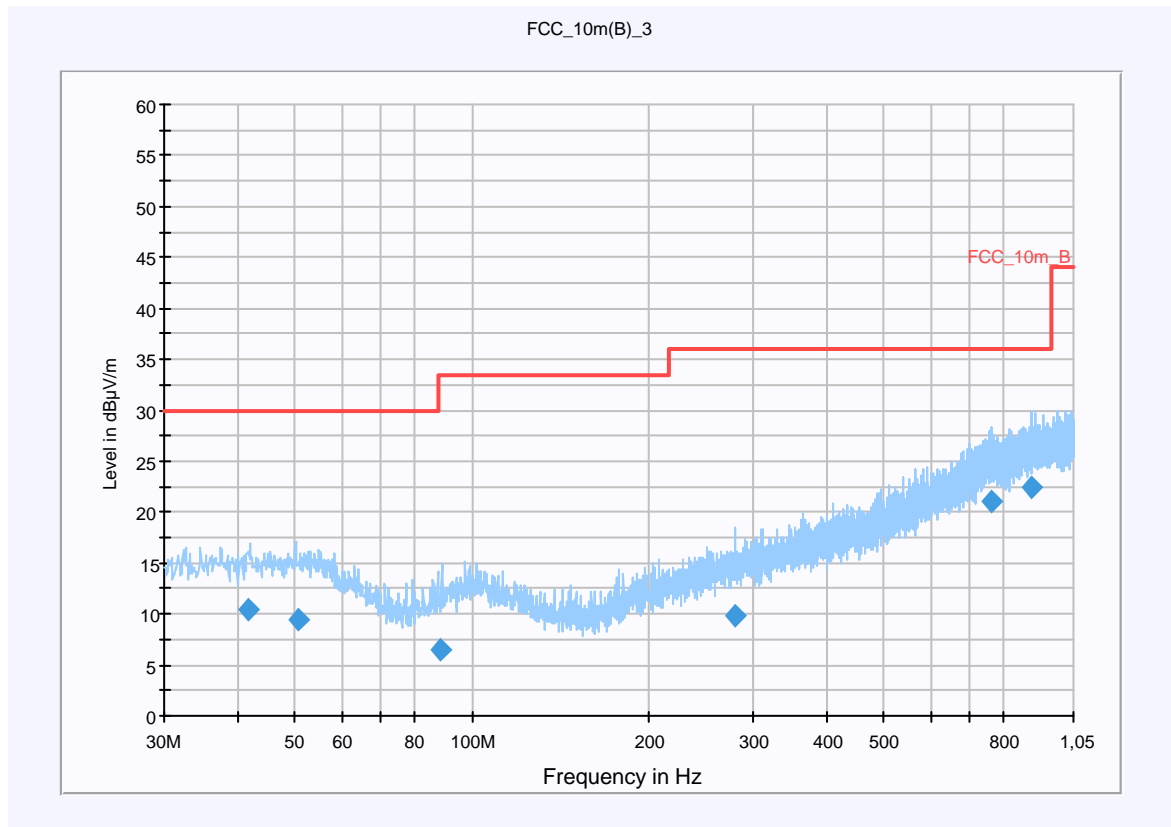

**Final Result 1**

Frequency (MHz)	QuasiPeak (dBµV/m)	Meas. Time (ms)	Bandwidth (kHz)	Antenna height (cm)	Polarity	Turntable position (deg)	Corr. (dB)	Margin (dB)	Limit (dBµV/m)	Comment
41.629350	10.4	15000.000	120.000	112.0	V	264.0	13.4	19.6	30.0	
50.599350	9.5	15000.000	120.000	98.0	H	128.0	13.3	20.5	30.0	
88.430850	6.4	15000.000	120.000	220.0	V	243.0	10.3	27.1	33.5	
280.068750	9.9	15000.000	120.000	220.0	V	289.0	14.1	26.1	36.0	
764.200350	21.0	15000.000	120.000	98.0	V	107.0	23.7	15.0	36.0	
893.451600	22.5	15000.000	120.000	105.0	V	30.0	25.1	13.5	36.0	



**Hardware Setup: EMI radiated\Electric Field (NOS) - [EMI radiated]**

Subrange 1	
Frequency Range:	30 MHz - 2 GHz
Receiver:	Receiver [ESCI 3] @ GPIB0 (ADR 20), SN 100083/003, FW 4.32
Signal Path:	without Notch FW 1.0
Antenna:	VULB 9163 SN 9163-295, FW --- Correction Table (vertical): VULP6113 Correction Table (horizontal): VULP6113 Correction Table: Cable_EN_1GHz (1005)
Antenna Tower:	Tower [EMCO 2090 Antenna Tower] @ GPIB0 (ADR 8), FW REV 3.12
Turntable:	Turntable [EMCO Turntable] @ GPIB0 (ADR 9), FW REV 3.12

EMC 32 Version 8.10.00

**Plot 12:** Highest channel, 1 GHz to 12.75 GHz, vertical polarization

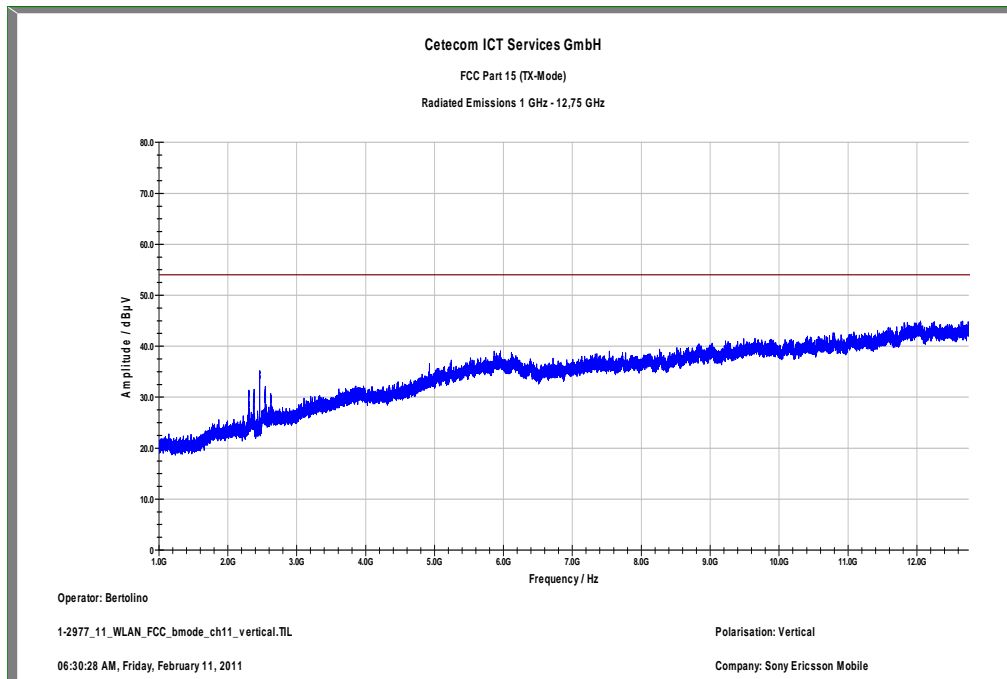

The carrier signal is notched with a 2.4 GHz band rejection filter.

Plot 13: Highest channel, 1 GHz to 12.75 GHz, horizontal polarization

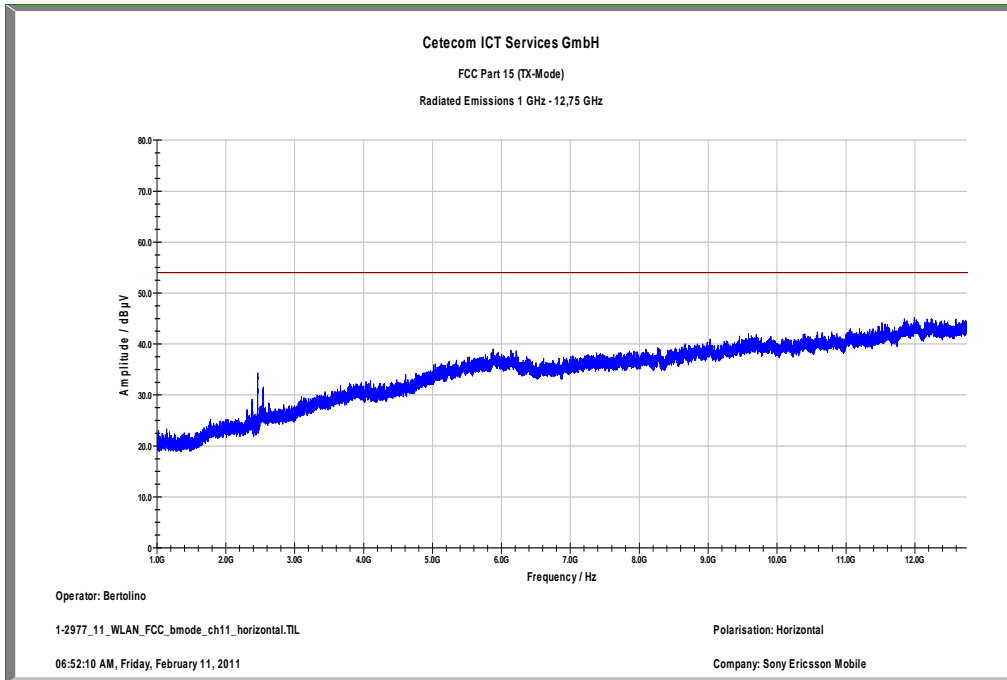

The carrier signal is notched with a 2.4 GHz band rejection filter.

Plot 14: Highest channel, 12.75 GHz to 18 GHz, vertical & horizontal polarization

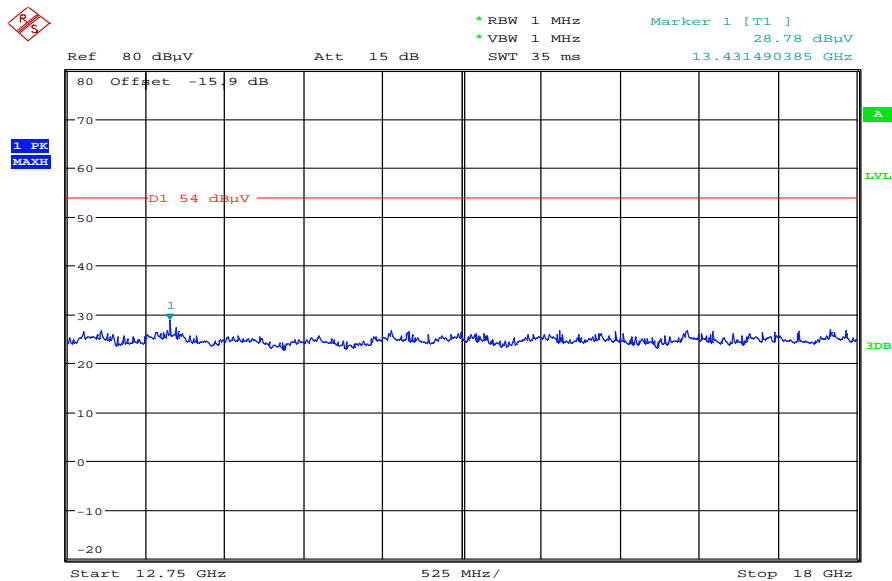

Date: 11.FEB.2011 09:20:02

Plot 15: Highest channel, 18 GHz to 26 GHz, vertical & horizontal polarization

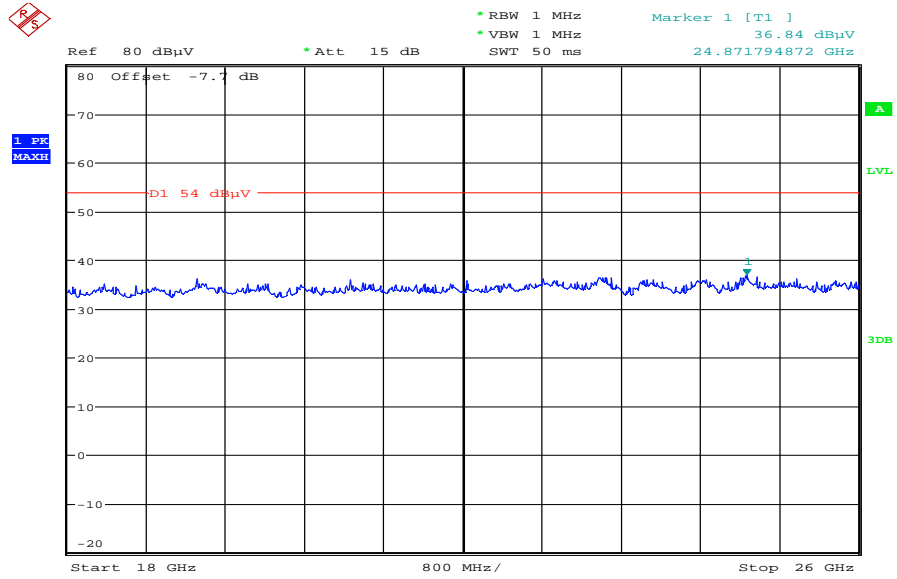

Date: 11.FEB.2011 09:48:54

**Plots: OFDM / g – mode**

**Plot 1:** Lowest channel, 30 MHz to 1 GHz, vertical & horizontal polarization

**CETECOM ICT Services GmbH**

**Common Information**

EUT: AAD-3880088-BV  
 Serial Number:  
 Test Description: FCC Part 15  
 Operating Conditions: WLAN 11 g & n (worst case), CH.1  
 Operator Name: LAN  
 Comment: AC 115V / 60 Hz

**Scan Setup: STAN\_Fin [EMI radiated]**

Hardware Setup: Electric Field (NOS)  
 Level Unit: dBµV/m

Subrange	Detectors	IF Bandwidth	Meas. Time	Receiver
30 MHz - 1,05 GHz	QuasiPeak	120 kHz	15 s	Receiver

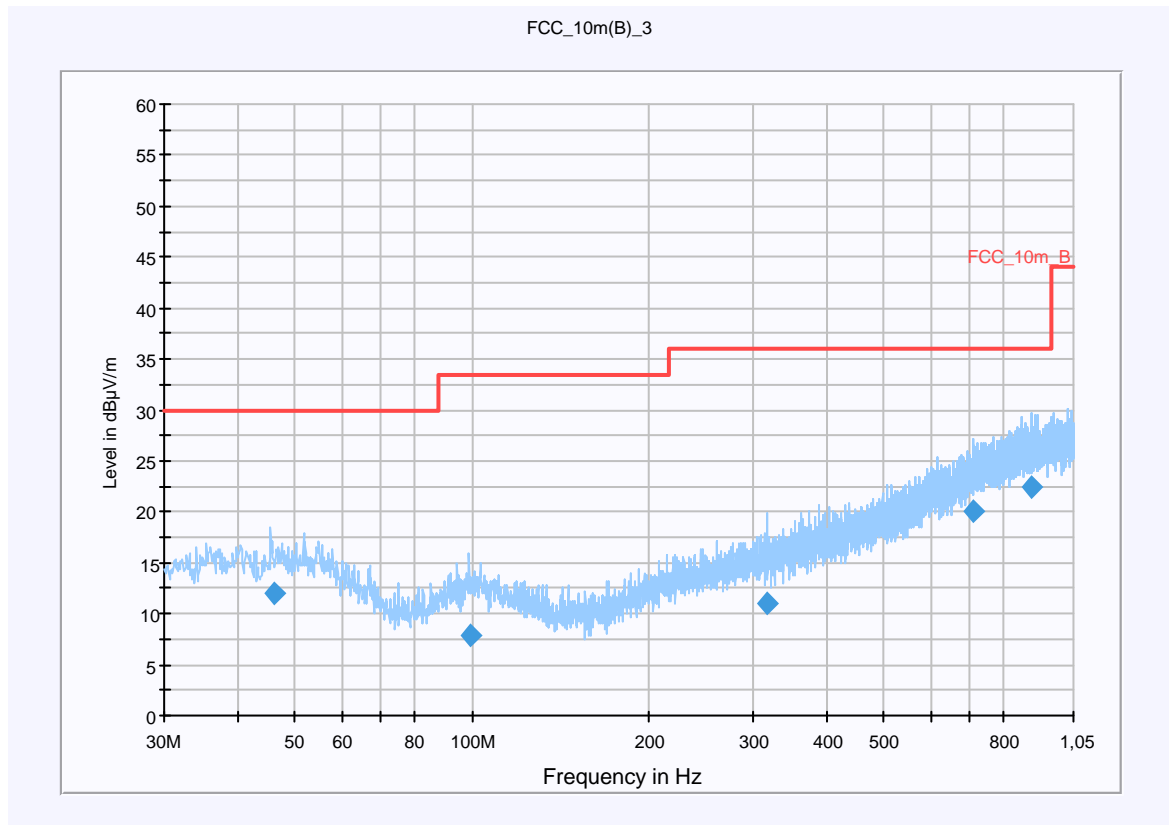

**Final Result 1**

Frequency (MHz)	QuasiPeak (dBµV/m)	Meas. Time (ms)	Bandwidth (kHz)	Antenna height (cm)	Polarity	Turntable position (deg)	Corr. (dB)	Margin (dB)	Limit (dBµV/m)	Comment
45.989850	11.9	15000.000	120.000	220.0	V	146.0	13.3	18.1	30.0	
99.487800	7.9	15000.000	120.000	131.0	V	187.0	11.8	25.6	33.5	
316.213800	11.0	15000.000	120.000	158.0	H	119.0	15.0	25.0	36.0	
707.623950	20.1	15000.000	120.000	220.0	V	82.0	22.7	15.9	36.0	
888.850050	22.4	15000.000	120.000	220.0	H	9.0	25.1	13.6	36.0	

**Hardware Setup: EMI radiated\Electric Field (NOS) - [EMI radiated]**

Subrange 1	
Frequency Range:	30 MHz - 2 GHz
Receiver:	Receiver [ESCI 3] @ GPIB0 (ADR 20), SN 100083/003, FW 4.32
Signal Path:	without Notch FW 1.0
Antenna:	VULB 9163 SN 9163-295, FW --- Correction Table (vertical): VULP6113 Correction Table (horizontal): VULP6113 Correction Table: Cable_EN_1GHz (1005)
Antenna Tower:	Tower [EMCO 2090 Antenna Tower] @ GPIB0 (ADR 8), FW REV 3.12
Turntable:	Turntable [EMCO Turntable] @ GPIB0 (ADR 9), FW REV 3.12

EMC 32 Version 8.10.00

**Plot 2:** Lowest channel, 1 GHz to 12.75 GHz, vertical polarization

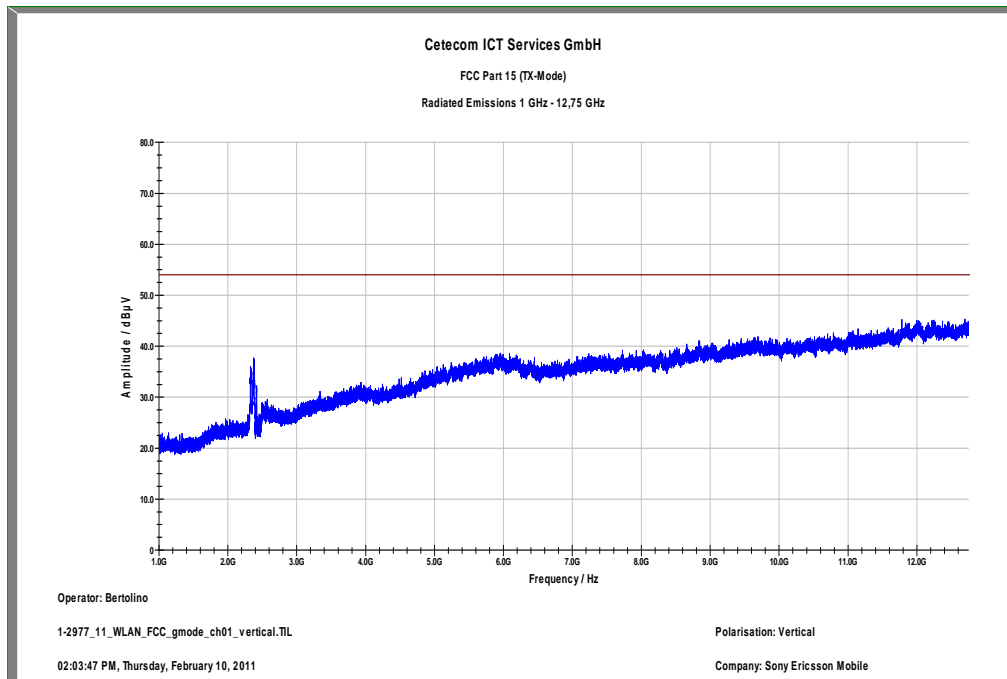

The carrier signal is notched with a 2.4 GHz band rejection filter.

**Plot 3:** Lowest channel, 1 GHz to 12.75 GHz, horizontal polarization

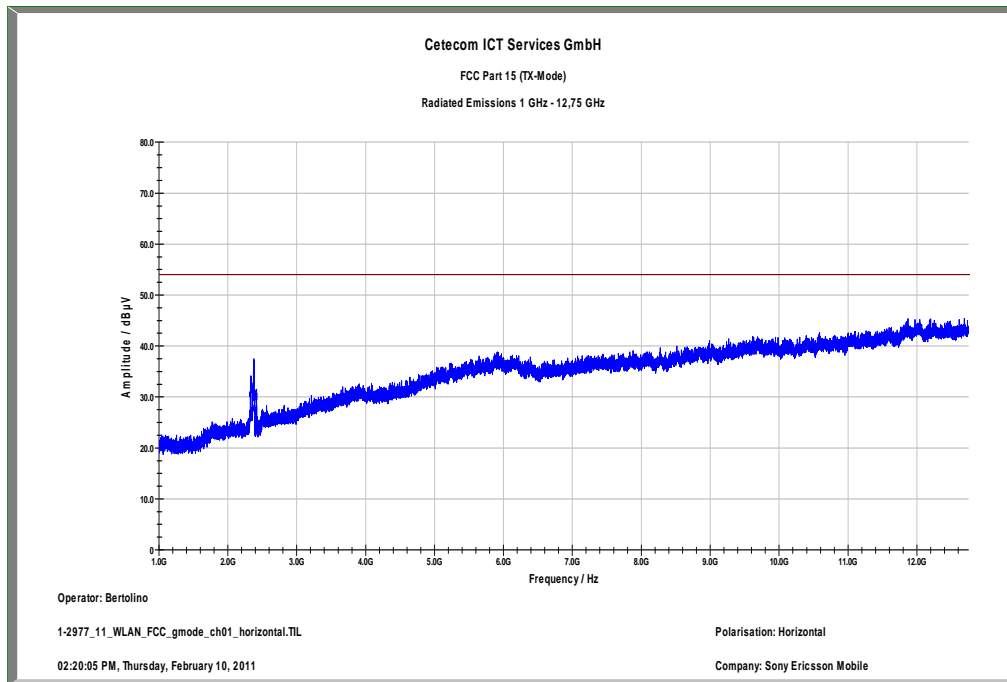

The carrier signal is notched with a 2.4 GHz band rejection filter.

**Plot 4:** Lowest channel, 12.75 GHz to 18 GHz, vertical & horizontal polarization

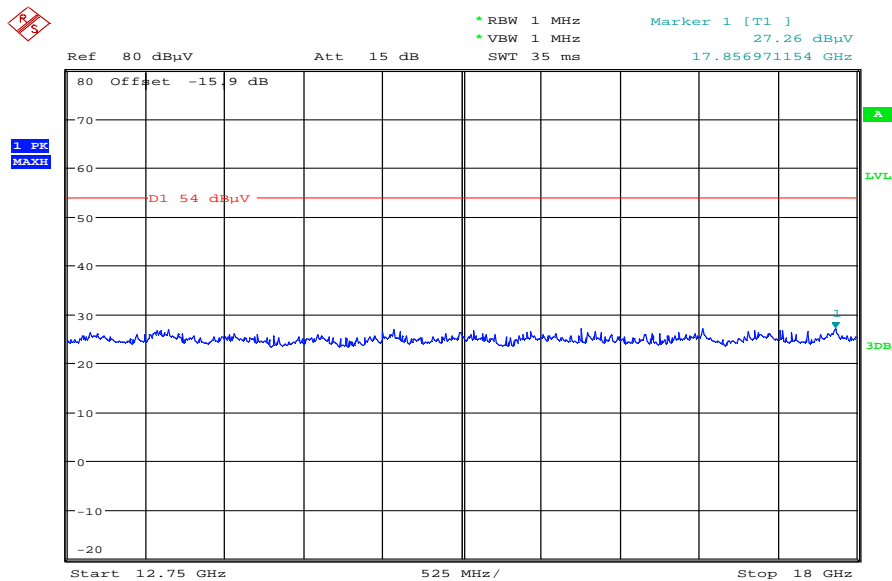

Date: 11.FEB.2011 09:22:08

Plot 5: Lowest channel, 18 GHz to 26 GHz, vertical & horizontal polarization

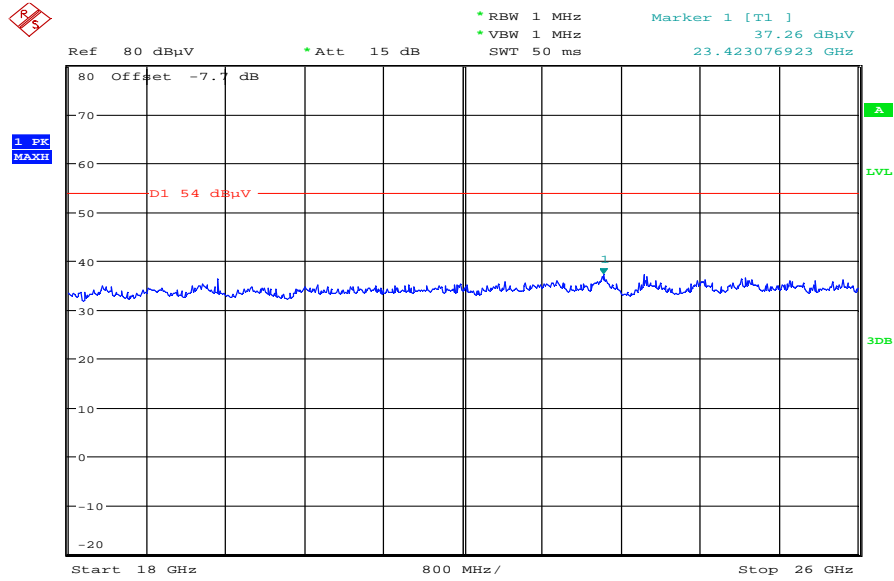

Date: 11.FEB.2011 09:49:58

**Plot 6:** Middle channel, 30 MHz to 1 GHz, vertical & horizontal polarization

**CETECOM ICT Services GmbH**

**Common Information**

EUT: AAD-3880088-BV  
 Serial Number:  
 Test Description: FCC Part 15  
 Operating Conditions: WLAN 11 g & n (worst case), CH.6  
 Operator Name: LAN  
 Comment: AC 115V / 60 Hz

**Scan Setup: STAN\_Fin [EMI radiated]**

Hardware Setup: Electric Field (NOS)  
 Level Unit: dBµV/m

Subrange	Detectors	IF Bandwidth	Meas. Time	Receiver
30 MHz - 1,05 GHz	QuasiPeak	120 kHz	15 s	Receiver

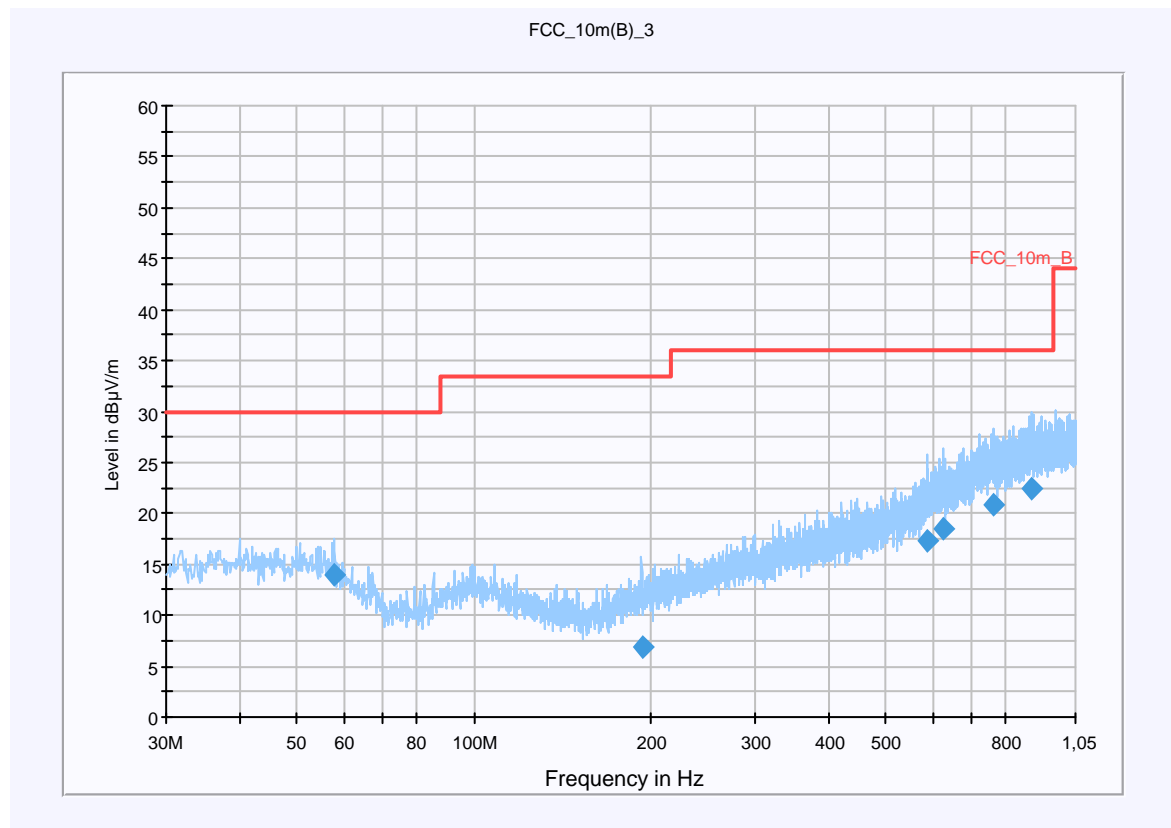

**Final Result 1**

Frequency (MHz)	QuasiPeak (dBµV/m)	Meas. Time (ms)	Bandwidth (kHz)	Antenna height (cm)	Polarity	Turntable position (deg)	Corr. (dB)	Margin (dB)	Limit (dBµV/m)	Comment
58.006200	14.0	15000.000	120.000	120.0	V	47.0	12.1	16.0	30.0	
193.033650	7.0	15000.000	120.000	206.0	V	27.0	11.3	26.5	33.5	
587.995350	17.2	15000.000	120.000	220.0	H	88.0	20.5	18.8	36.0	
628.402350	18.4	15000.000	120.000	148.0	H	53.0	21.0	17.6	36.0	
760.092750	20.9	15000.000	120.000	118.0	V	299.0	23.7	15.1	36.0	
...	...	...	...	...	...	...	...	...	...	...



**Hardware Setup: EMI radiated\Electric Field (NOS) - [EMI radiated]**

Subrange 1	
Frequency Range:	30 MHz - 2 GHz
Receiver:	Receiver [ESCI 3] @ GPIB0 (ADR 20), SN 100083/003, FW 4.32
Signal Path:	without Notch FW 1.0
Antenna:	VULB 9163 SN 9163-295, FW --- Correction Table (vertical): VULP6113 Correction Table (horizontal): VULP6113 Correction Table: Cable_EN_1GHz (1005)
Antenna Tower:	Tower [EMCO 2090 Antenna Tower] @ GPIB0 (ADR 8), FW REV 3.12
Turntable:	Turntable [EMCO Turntable] @ GPIB0 (ADR 9), FW REV 3.12

EMC 32 Version 8.10.00

**Plot 7:** Middle channel, 1 GHz to 12.75 GHz, vertical polarization

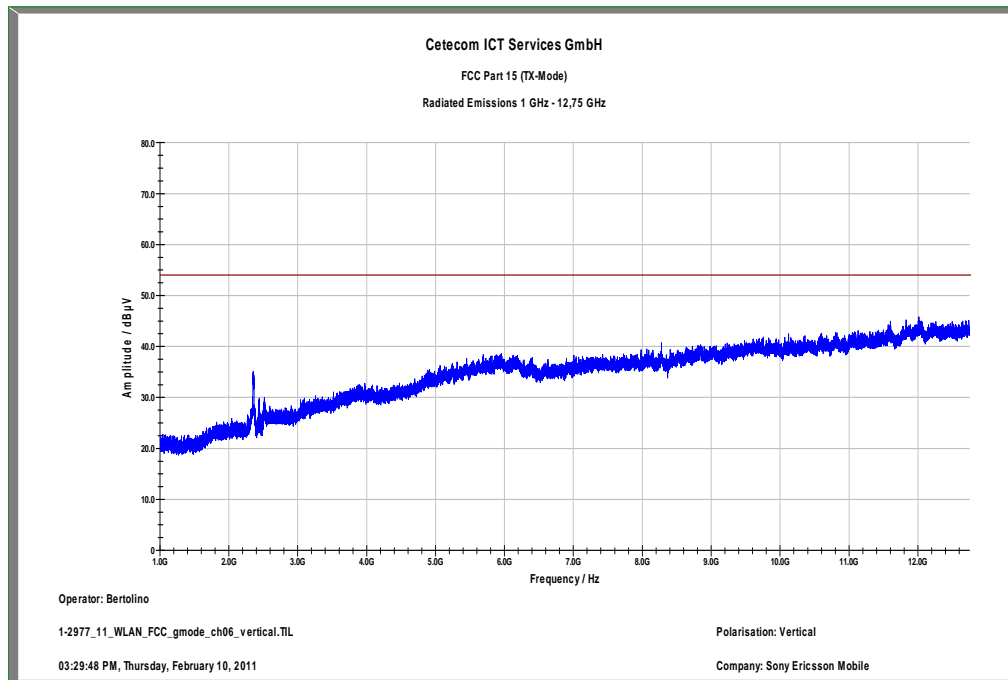

The carrier signal is notched with a 2.4 GHz band rejection filter.

**Plot 8:** Middle channel, 1 GHz to 12.75 GHz, horizontal polarization

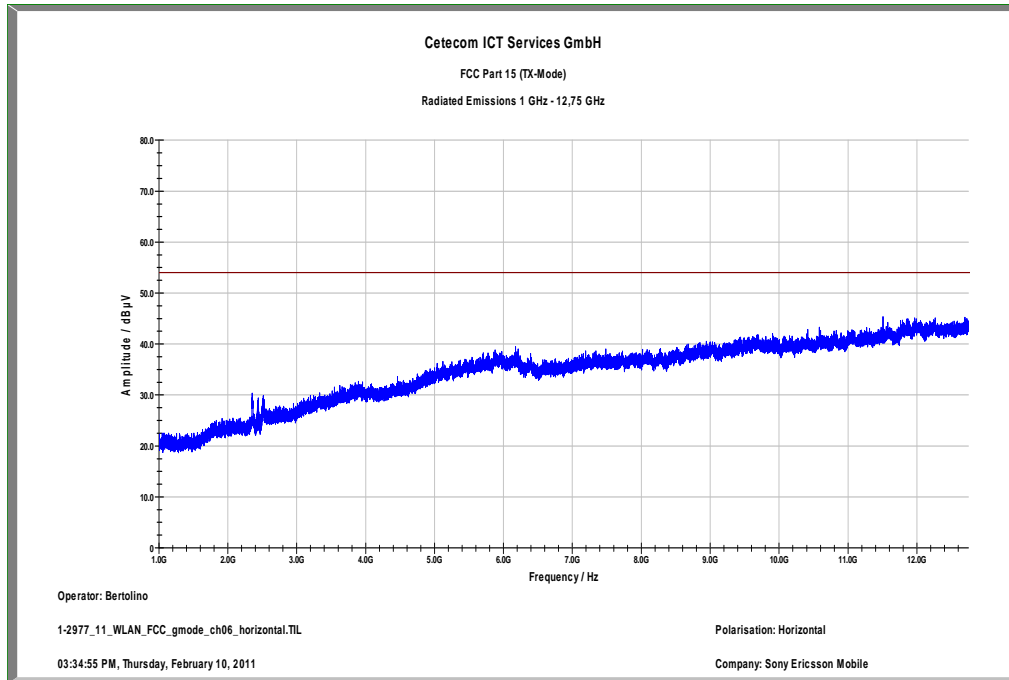

The carrier signal is notched with a 2.4 GHz band rejection filter.

**Plot 9:** Middle channel, 12.75 GHz to 18 GHz, vertical & horizontal polarization

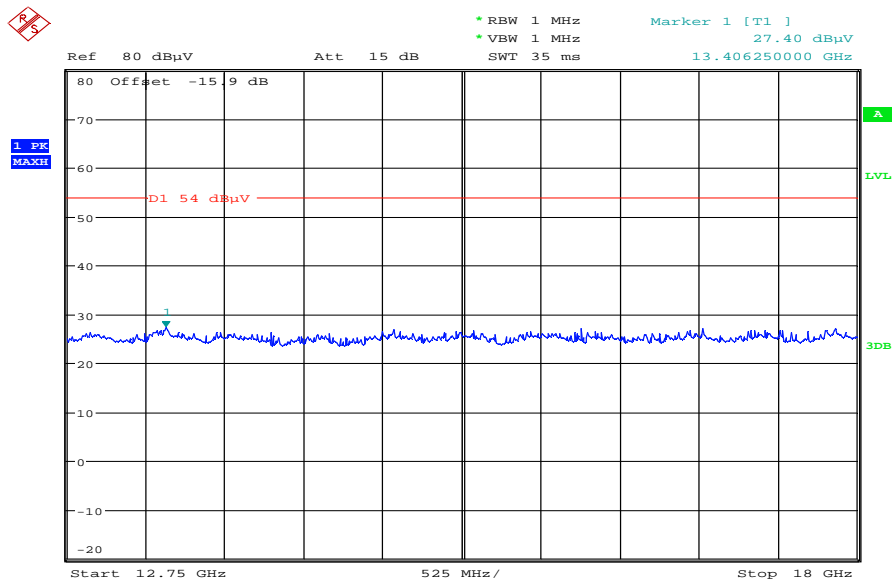

Date: 11.FEB.2011 09:23:15

Plot 10: Middle channel, 18 GHz to 26 GHz, vertical & horizontal polarization

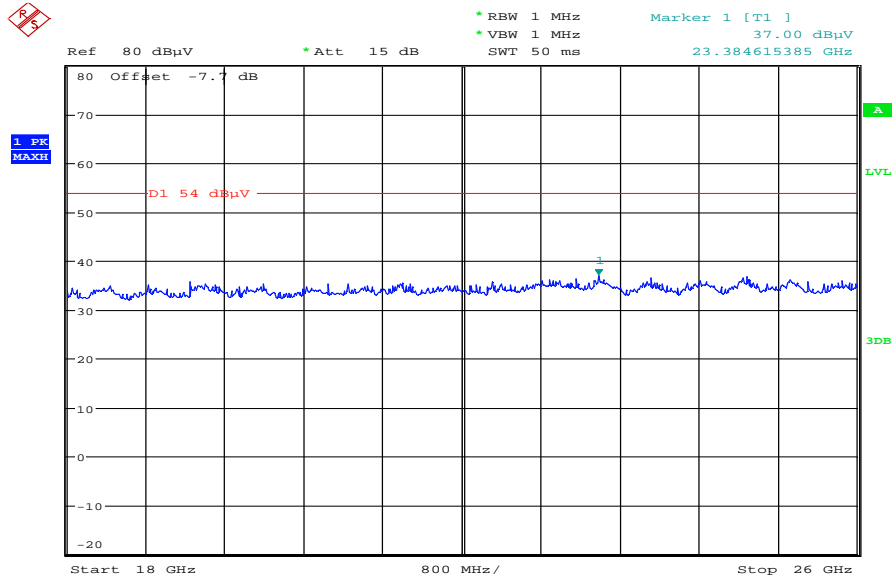

Date: 11.FEB.2011 09:51:06

Plot 11: Highest channel, 30 MHz to 1 GHz, vertical & horizontal polarization

### CETECOM ICT Services GmbH

#### Common Information

EUT: AAD-3880088-BV  
 Serial Number:  
 Test Description: FCC Part 15  
 Operating Conditions: WLAN 11 g & n (worst case), CH.11  
 Operator Name: LAN  
 Comment: AC 115V / 60 Hz

#### Scan Setup: STAN\_Fin [EMI radiated]

Hardware Setup: Electric Field (NOS)  
 Level Unit: dBµV/m

Subrange	Detectors	IF Bandwidth	Meas. Time	Receiver
30 MHz - 1,05 GHz	QuasiPeak	120 kHz	15 s	Receiver

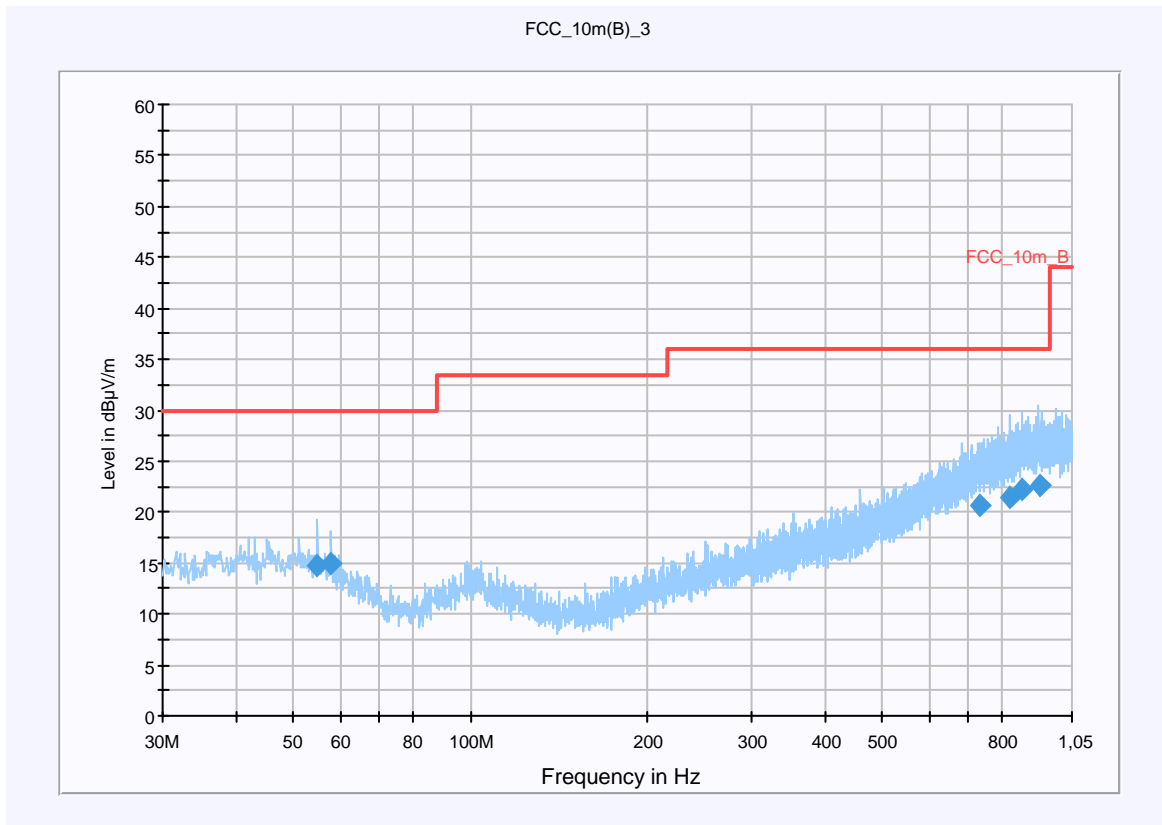

#### Final Result 1

Frequency (MHz)	QuasiPeak (dBµV/m)	Meas. Time (ms)	Bandwidth (kHz)	Antenna height (cm)	Polarity	Turntable position (deg)	Corr. (dB)	Margin (dB)	Limit (dBµV/m)	Comment
54.997650	14.7	15000.000	120.000	220.0	V	283.0	12.9	15.3	30.0	
58.005900	15.0	15000.000	120.000	98.0	V	21.0	12.1	15.0	30.0	
732.085800	20.6	15000.000	120.000	220.0	V	146.0	23.2	15.4	36.0	
821.716050	21.4	15000.000	120.000	220.0	V	39.0	24.1	14.6	36.0	
866.546550	22.2	15000.000	120.000	220.0	V	97.0	24.8	13.8	36.0	
...	...	...	...	...	...	...	...	...	...	...

**Hardware Setup: EMI radiated\Electric Field (NOS) - [EMI radiated]**

Subrange 1	
Frequency Range:	30 MHz - 2 GHz
Receiver:	Receiver [ESCI 3] @ GPIB0 (ADR 20), SN 100083/003, FW 4.32
Signal Path:	without Notch FW 1.0
Antenna:	VULB 9163 SN 9163-295, FW --- Correction Table (vertical): VULP6113 Correction Table (horizontal): VULP6113 Correction Table: Cable_EN_1GHz (1005)
Antenna Tower:	Tower [EMCO 2090 Antenna Tower] @ GPIB0 (ADR 8), FW REV 3.12
Turntable:	Turntable [EMCO Turntable] @ GPIB0 (ADR 9), FW REV 3.12

EMC 32 Version 8.10.00

**Plot 12:** Highest channel, 1 GHz to 12.75 GHz, vertical polarization

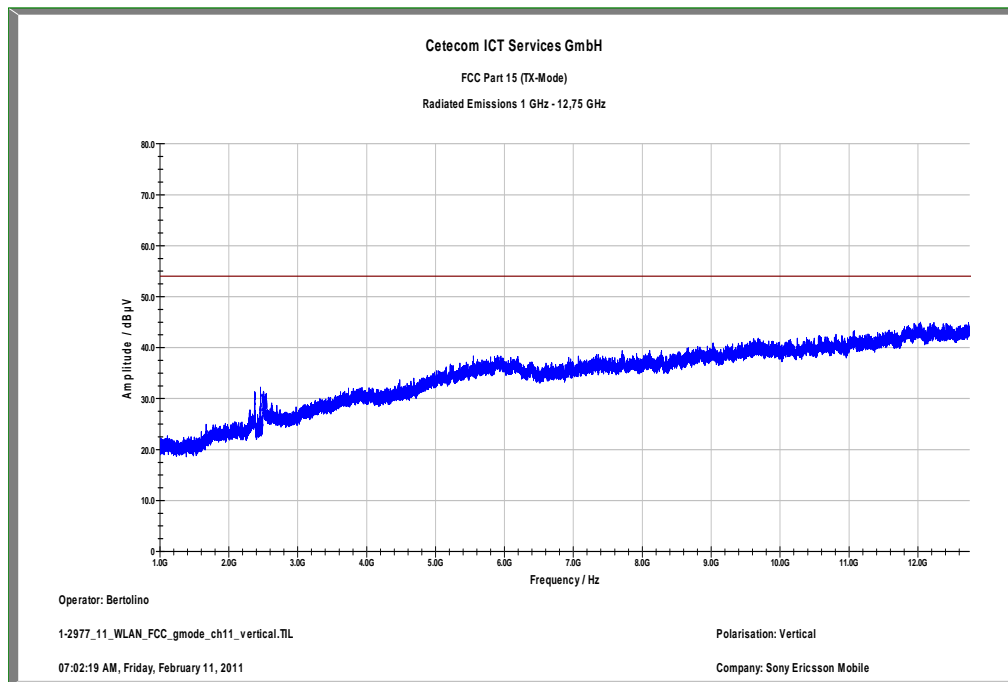

The carrier signal is notched with a 2.4 GHz band rejection filter.

**Plot 13:** Highest channel, 1 GHz to 12.75 GHz, horizontal polarization

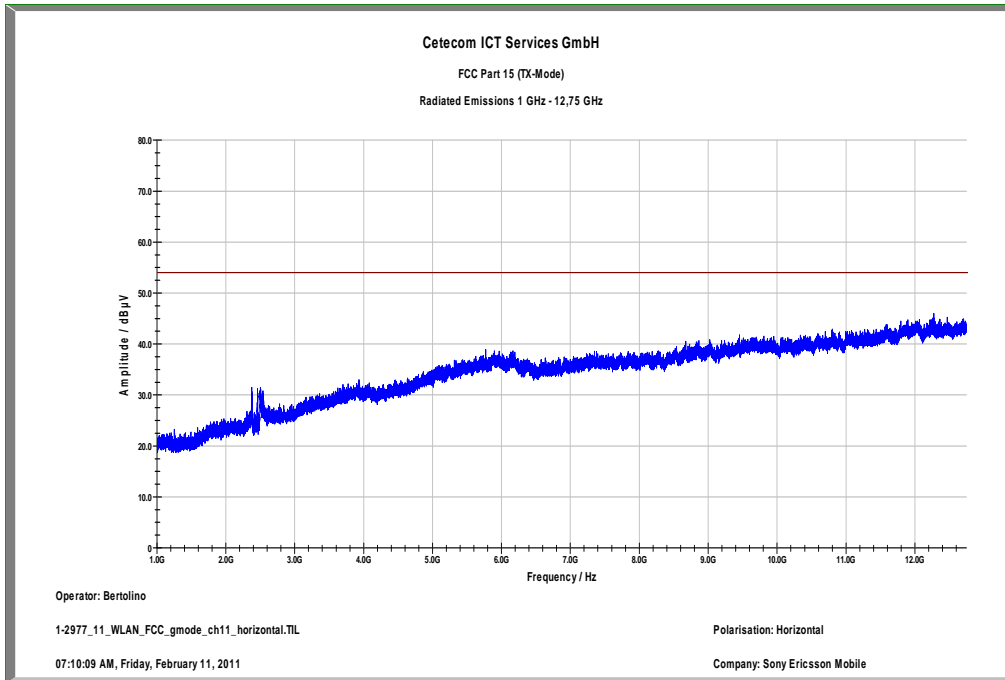

The carrier signal is notched with a 2.4 GHz band rejection filter.

**Plot 14:** Highest channel, 12.75 GHz to 18 GHz, vertical & horizontal polarization

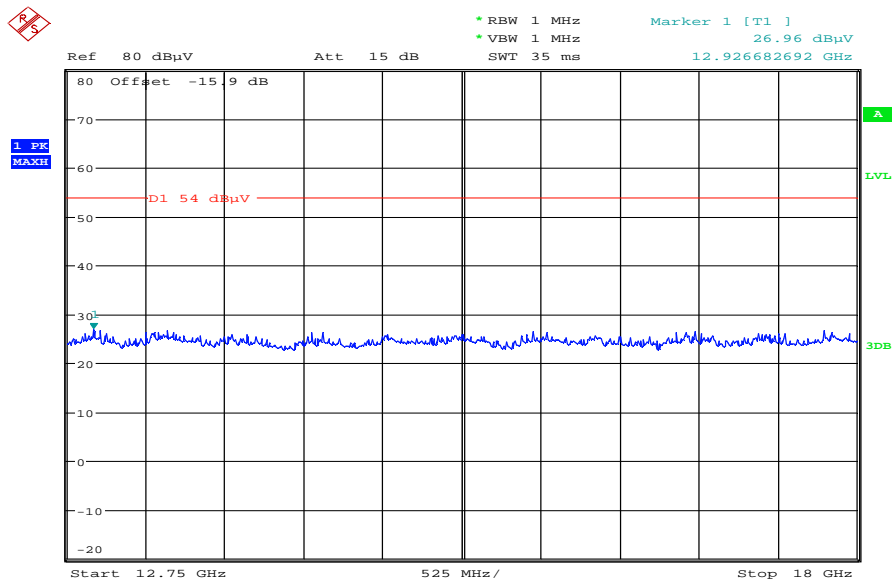

Date: 11.FEB.2011 09:24:00

Plot 15: Highest channel, 18 GHz to 26 GHz, vertical & horizontal polarization

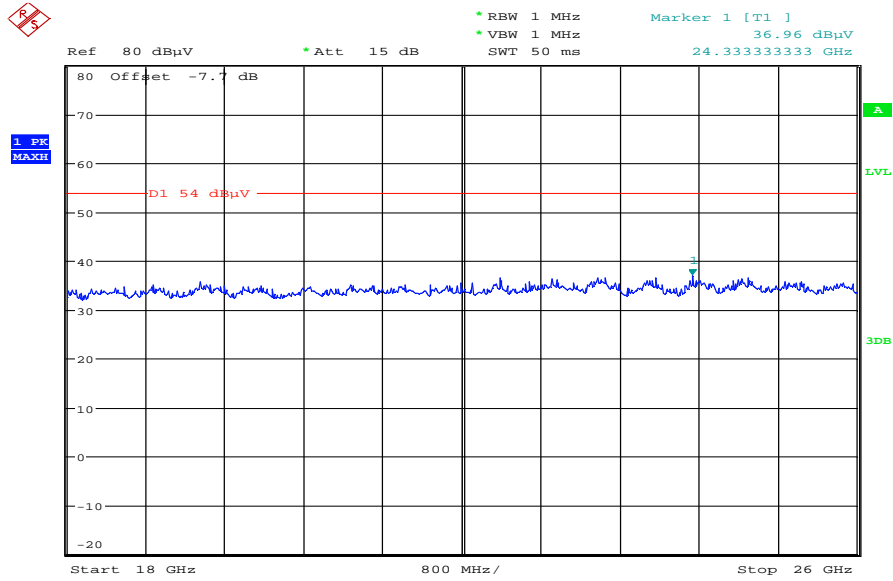

Date: 11.FEB.2011 09:52:17

**Plots: OFDM / n – mode**

**Plot 1:** Lowest channel, 30 MHz to 1 GHz, vertical & horizontal polarization

**CETECOM ICT Services GmbH**

**Common Information**

EUT: AAD-3880088-BV  
 Serial Number:  
 Test Description: FCC Part 15  
 Operating Conditions: WLAN 11 g & n (worst case), CH.1  
 Operator Name: LAN  
 Comment: AC 115V / 60 Hz

**Scan Setup: STAN\_Fin [EMI radiated]**

Hardware Setup: Electric Field (NOS)  
 Level Unit: dBµV/m

Subrange	Detectors	IF Bandwidth	Meas. Time	Receiver
30 MHz - 1,05 GHz	QuasiPeak	120 kHz	15 s	Receiver

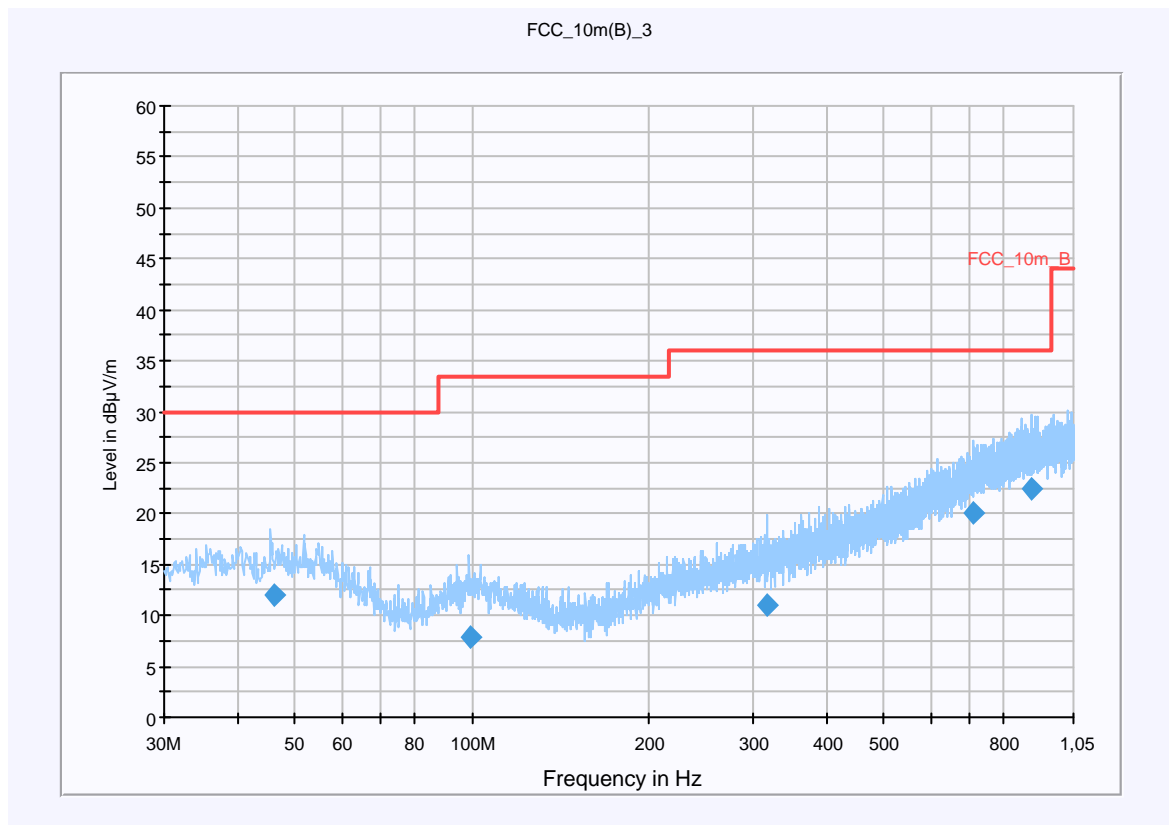

**Final Result 1**

Frequency (MHz)	QuasiPeak (dBµV/m)	Meas. Time (ms)	Bandwidth (kHz)	Antenna height (cm)	Polarity	Turntable position (deg)	Corr. (dB)	Margin (dB)	Limit (dBµV/m)	Comment
45.989850	11.9	15000.000	120.000	220.0	V	146.0	13.3	18.1	30.0	
99.487800	7.9	15000.000	120.000	131.0	V	187.0	11.8	25.6	33.5	
316.213800	11.0	15000.000	120.000	158.0	H	119.0	15.0	25.0	36.0	
707.623950	20.1	15000.000	120.000	220.0	V	82.0	22.7	15.9	36.0	
888.850050	22.4	15000.000	120.000	220.0	H	9.0	25.1	13.6	36.0	



**Hardware Setup: EMI radiated\Electric Field (NOS) - [EMI radiated]**

Subrange 1	
Frequency Range:	30 MHz - 2 GHz
Receiver:	Receiver [ESCI 3] @ GPIB0 (ADR 20), SN 100083/003, FW 4.32
Signal Path:	without Notch FW 1.0
Antenna:	VULB 9163 SN 9163-295, FW --- Correction Table (vertical): VULP6113 Correction Table (horizontal): VULP6113 Correction Table: Cable_EN_1GHz (1005)
Antenna Tower:	Tower [EMCO 2090 Antenna Tower] @ GPIB0 (ADR 8), FW REV 3.12
Turntable:	Turntable [EMCO Turntable] @ GPIB0 (ADR 9), FW REV 3.12

EMC 32 Version 8.10.00

**Plot 2:** Lowest channel, 1 GHz to 12.75 GHz, vertical polarization

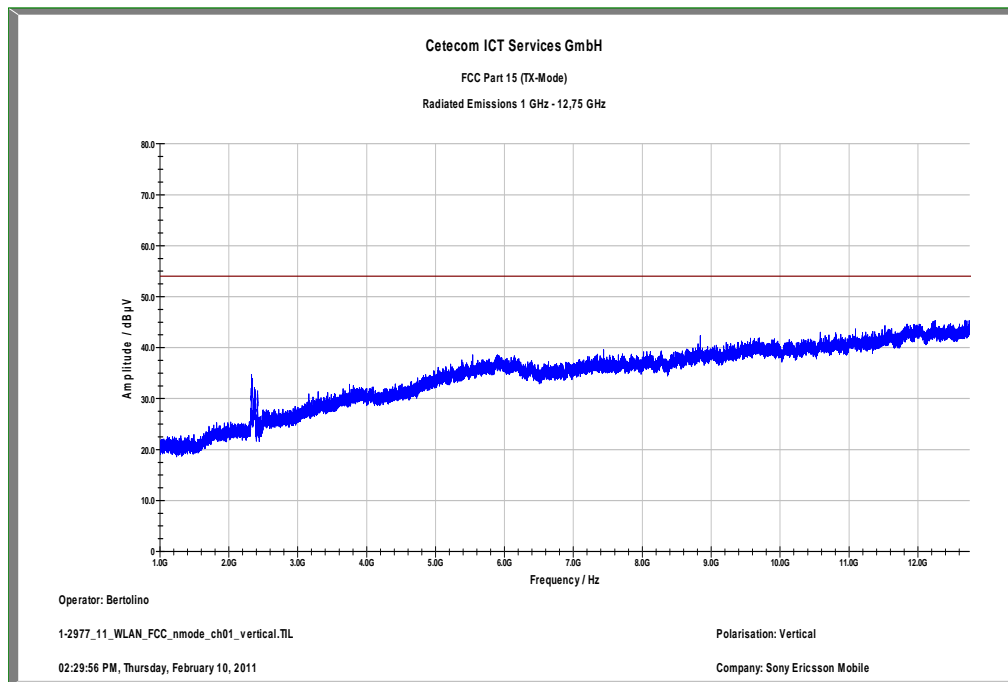

The carrier signal is notched with a 2.4 GHz band rejection filter.

**Plot 3:** Lowest channel, 1 GHz to 12.75 GHz, horizontal polarization

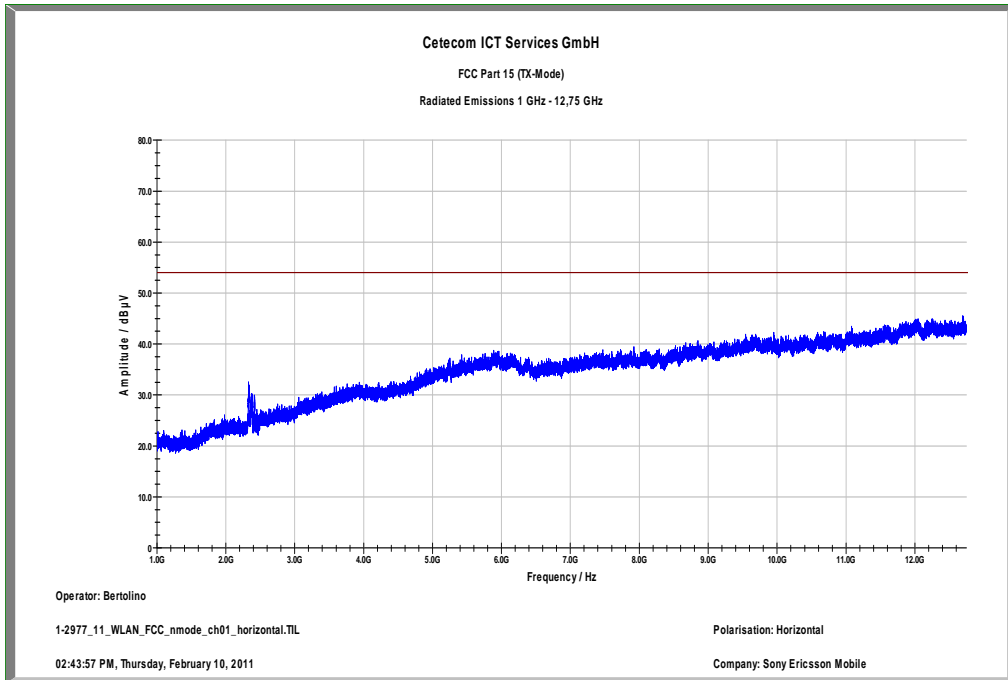

The carrier signal is notched with a 2.4 GHz band rejection filter.

**Plot 4:** Lowest channel, 12.75 GHz to 18 GHz, vertical & horizontal polarization

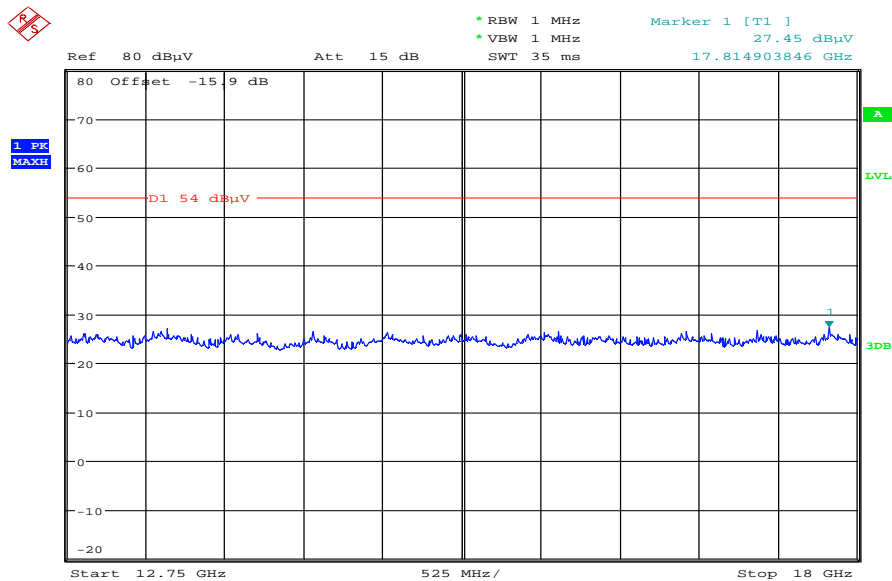

Date: 11.FEB.2011 09:25:00

Plot 5: Lowest channel, 18 GHz to 26 GHz, vertical & horizontal polarization

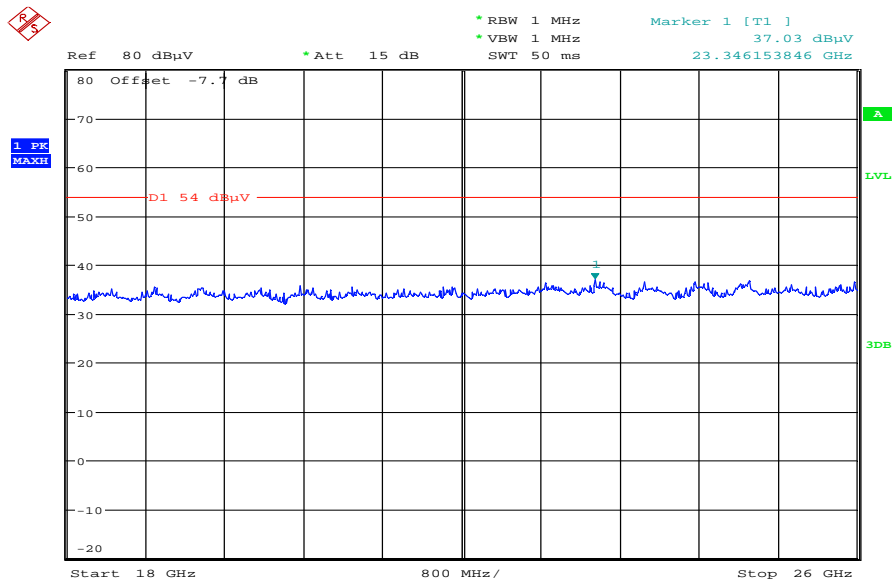

Date: 11.FEB.2011 09:53:33

**Plot 6:** Middle channel, 30 MHz to 1 GHz, vertical & horizontal polarization

**CETECOM ICT Services GmbH**

**Common Information**

EUT: AAD-3880088-BV  
 Serial Number:  
 Test Description: FCC Part 15  
 Operating Conditions: WLAN 11 g & n (worst case), CH.6  
 Operator Name: LAN  
 Comment: AC 115V / 60 Hz

**Scan Setup: STAN\_Fin [EMI radiated]**

Hardware Setup: Electric Field (NOS)  
 Level Unit: dBµV/m  
**Subrange**                      **Detectors**                      **IF Bandwidth**                      **Meas. Time**                      **Receiver**  
 30 MHz - 1,05 GHz              QuasiPeak                      120 kHz                      15 s                      Receiver

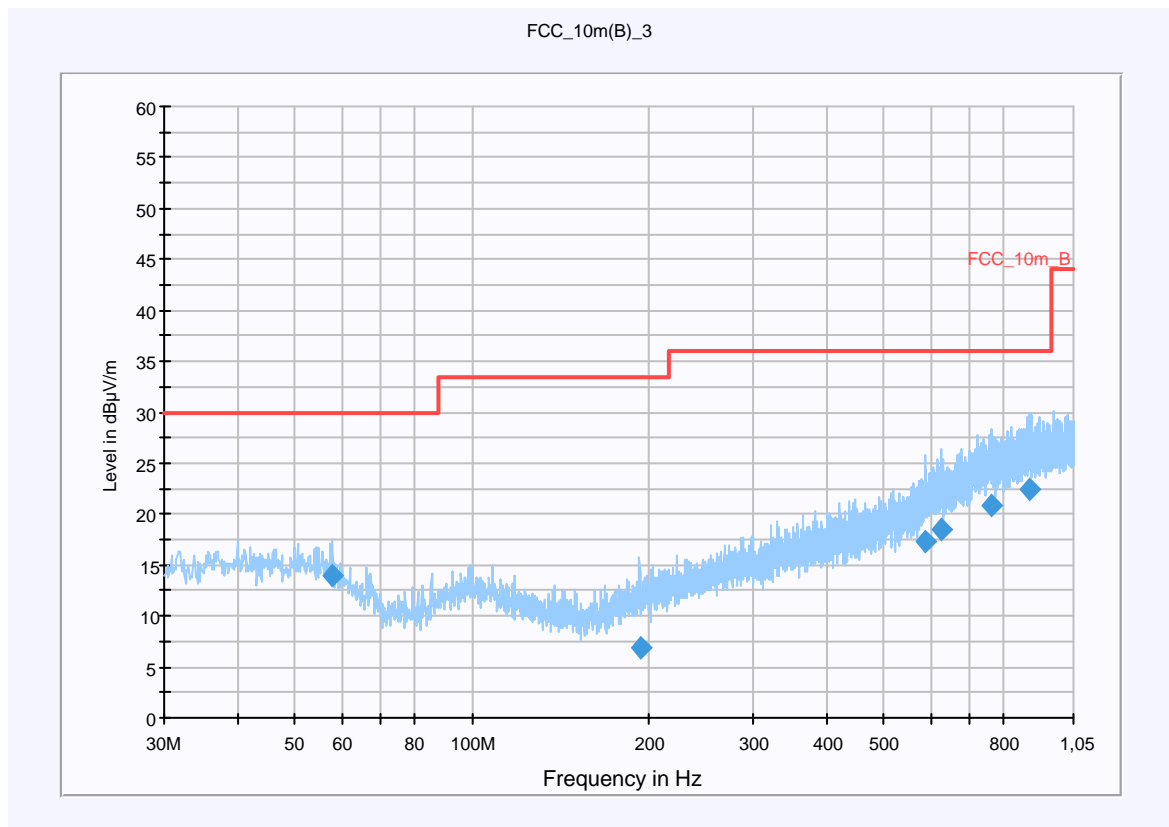

**Final Result 1**

Frequency (MHz)	QuasiPeak (dBµV/m)	Meas. Time (ms)	Bandwidth (kHz)	Antenna height (cm)	Polarity	Turntable position (deg)	Corr. (dB)	Margin (dB)	Limit (dBµV/m)	Comment
58.006200	14.0	15000.000	120.000	120.0	V	47.0	12.1	16.0	30.0	
193.033650	7.0	15000.000	120.000	206.0	V	27.0	11.3	26.5	33.5	
587.995350	17.2	15000.000	120.000	220.0	H	88.0	20.5	18.8	36.0	
628.402350	18.4	15000.000	120.000	148.0	H	53.0	21.0	17.6	36.0	
760.092750	20.9	15000.000	120.000	118.0	V	299.0	23.7	15.1	36.0	
...	...	...	...	...	...	...	...	...	...	...

**Hardware Setup: EMI radiated\Electric Field (NOS) - [EMI radiated]**

Subrange 1	
Frequency Range:	30 MHz - 2 GHz
Receiver:	Receiver [ESCI 3] @ GPIB0 (ADR 20), SN 100083/003, FW 4.32
Signal Path:	without Notch FW 1.0
Antenna:	VULB 9163 SN 9163-295, FW --- Correction Table (vertical): VULP6113 Correction Table (horizontal): VULP6113 Correction Table: Cable_EN_1GHz (1005)
Antenna Tower:	Tower [EMCO 2090 Antenna Tower] @ GPIB0 (ADR 8), FW REV 3.12
Turntable:	Turntable [EMCO Turntable] @ GPIB0 (ADR 9), FW REV 3.12

EMC 32 Version 8.10.00

**Plot 7:** Middle channel, 1 GHz to 12.75 GHz, vertical polarization

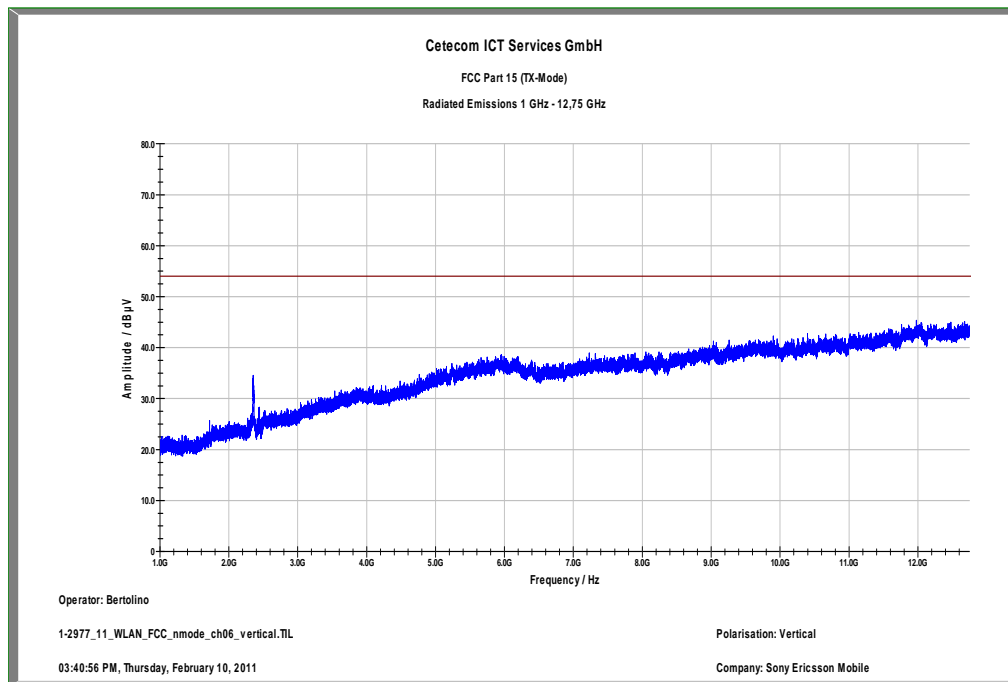

The carrier signal is notched with a 2.4 GHz band rejection filter.

**Plot 8:** Middle channel, 1 GHz to 12.75 GHz, horizontal polarization

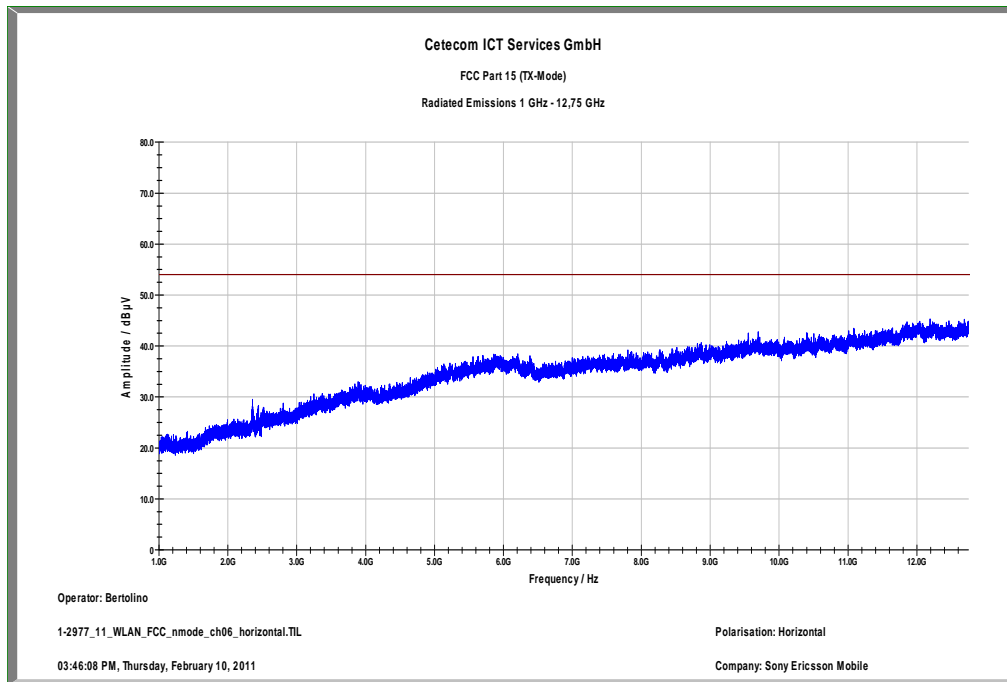

The carrier signal is notched with a 2.4 GHz band rejection filter.

**Plot 9:** Middle channel, 12.75 GHz to 18 GHz, vertical & horizontal polarization

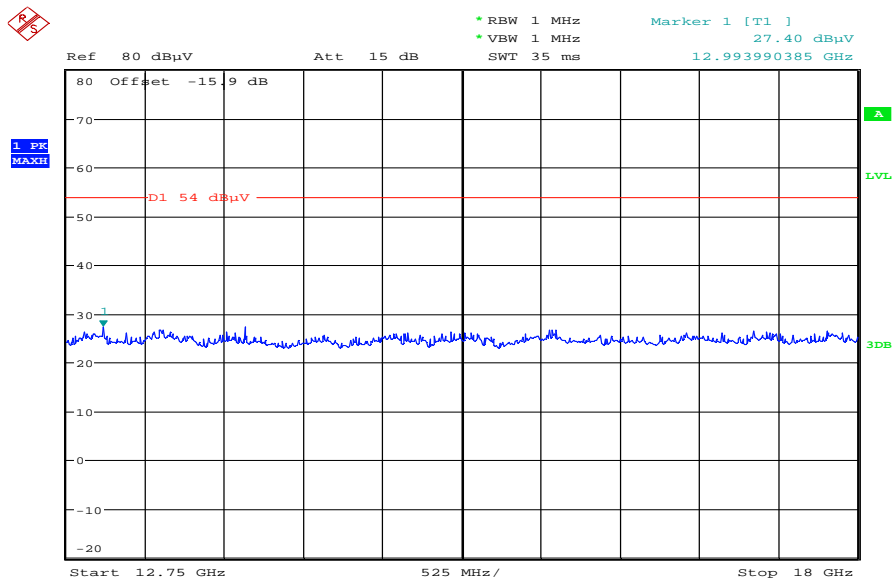

Date: 11.FEB.2011 09:26:01

Plot 10: Middle channel, 18 GHz to 26 GHz, vertical & horizontal polarization

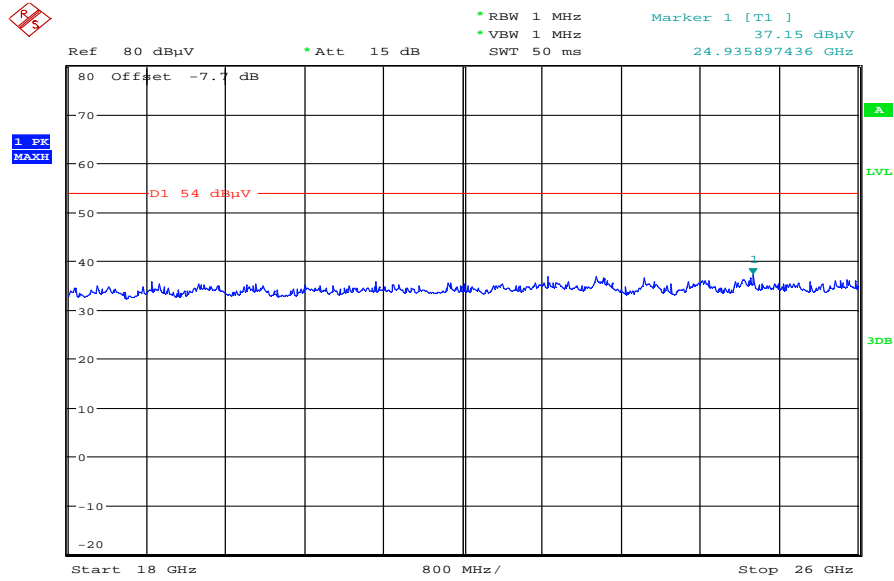

Date: 11.FEB.2011 09:54:50

Plot 11: Highest channel, 30 MHz to 1 GHz, vertical & horizontal polarization

**CETECOM ICT Services GmbH**

**Common Information**

EUT: AAD-3880088-BV  
 Serial Number:  
 Test Description: FCC Part 15  
 Operating Conditions: WLAN 11 g & n (worst case), CH.11  
 Operator Name: LAN  
 Comment: AC 115V / 60 Hz

**Scan Setup: STAN\_Fin [EMI radiated]**

Hardware Setup: Electric Field (NOS)  
 Level Unit: dBµV/m  
**Subrange**                      **Detectors**                      **IF Bandwidth**                      **Meas. Time**                      **Receiver**  
 30 MHz - 1,05 GHz              QuasiPeak                      120 kHz                      15 s                      Receiver

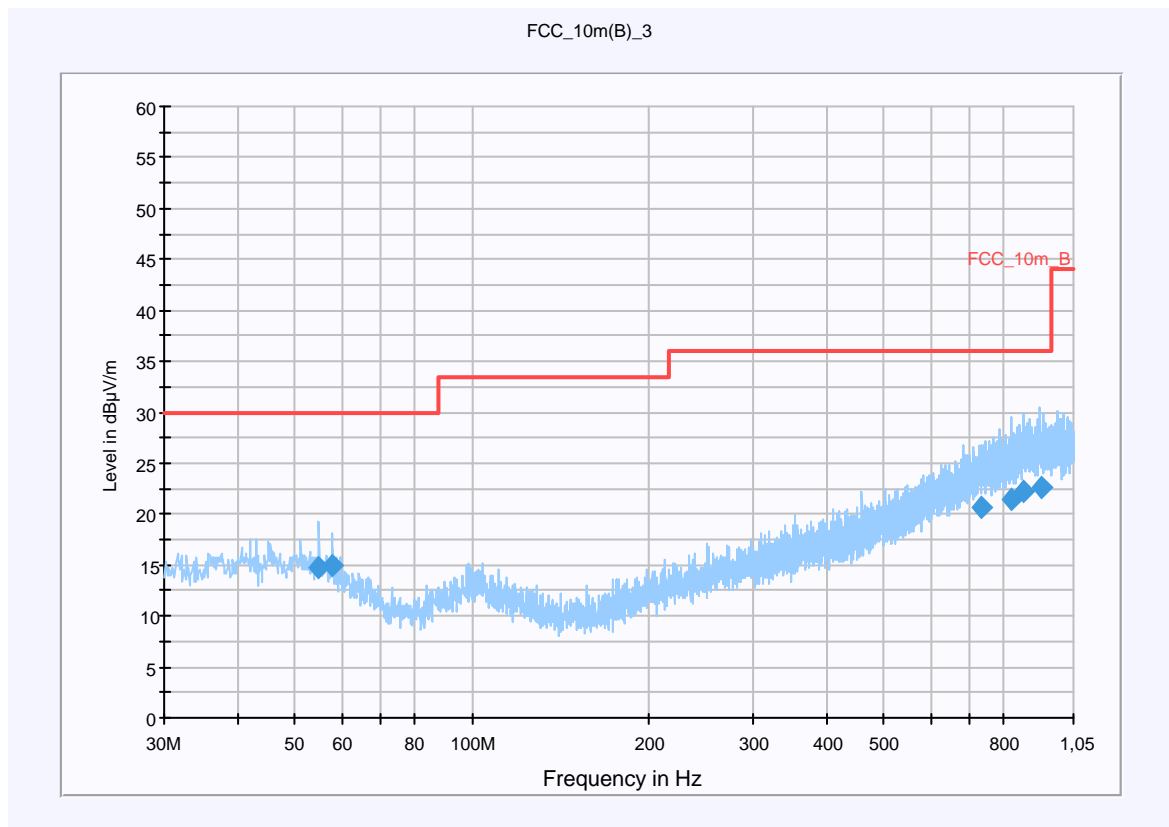

**Final Result 1**

Frequency (MHz)	QuasiPeak (dBµV/m)	Meas. Time (ms)	Bandwidth (kHz)	Antenna height (cm)	Polarity	Turntable position (deg)	Corr. (dB)	Margin (dB)	Limit (dBµV/m)	Comment
54.997650	14.7	15000.000	120.000	220.0	V	283.0	12.9	15.3	30.0	
58.005900	15.0	15000.000	120.000	98.0	V	21.0	12.1	15.0	30.0	
732.085800	20.6	15000.000	120.000	220.0	V	146.0	23.2	15.4	36.0	
821.716050	21.4	15000.000	120.000	220.0	V	39.0	24.1	14.6	36.0	
866.546550	22.2	15000.000	120.000	220.0	V	97.0	24.8	13.8	36.0	
...	...	...	...	...	...	...	...	...	...	...



**Hardware Setup: EMI radiated\Electric Field (NOS) - [EMI radiated]**

Subrange 1	
Frequency Range:	30 MHz - 2 GHz
Receiver:	Receiver [ESCI 3] @ GPIB0 (ADR 20), SN 100083/003, FW 4.32
Signal Path:	without Notch FW 1.0
Antenna:	VULB 9163 SN 9163-295, FW --- Correction Table (vertical): VULP6113 Correction Table (horizontal): VULP6113 Correction Table: Cable_EN_1GHz (1005)
Antenna Tower:	Tower [EMCO 2090 Antenna Tower] @ GPIB0 (ADR 8), FW REV 3.12
Turntable:	Turntable [EMCO Turntable] @ GPIB0 (ADR 9), FW REV 3.12

EMC 32 Version 8.10.00

**Plot 12:** Highest channel, 1 GHz to 12.75 GHz, vertical polarization

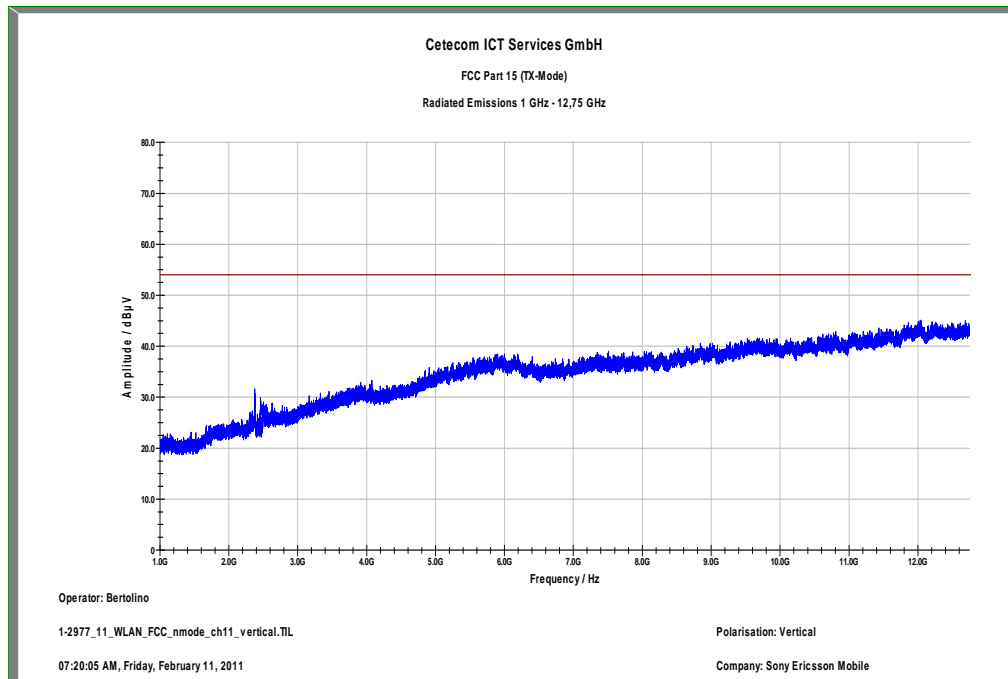

The carrier signal is notched with a 2.4 GHz band rejection filter.

Plot 13: Highest channel, 1 GHz to 12.75 GHz, horizontal polarization

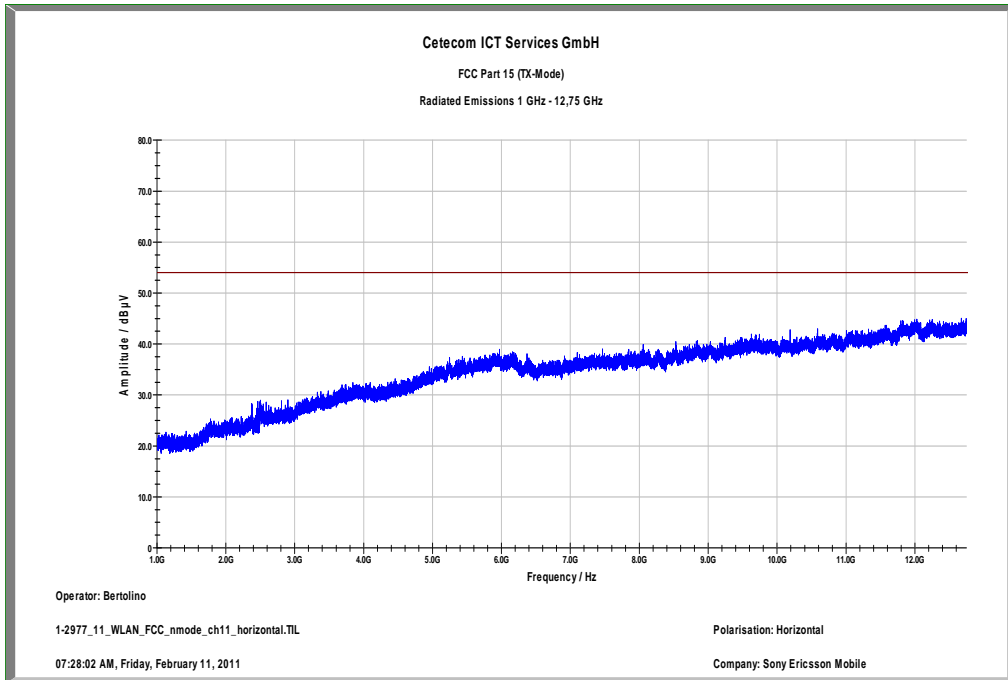

The carrier signal is notched with a 2.4 GHz band rejection filter.

Plot 14: Highest channel, 12.75 GHz to 18 GHz, vertical & horizontal polarization

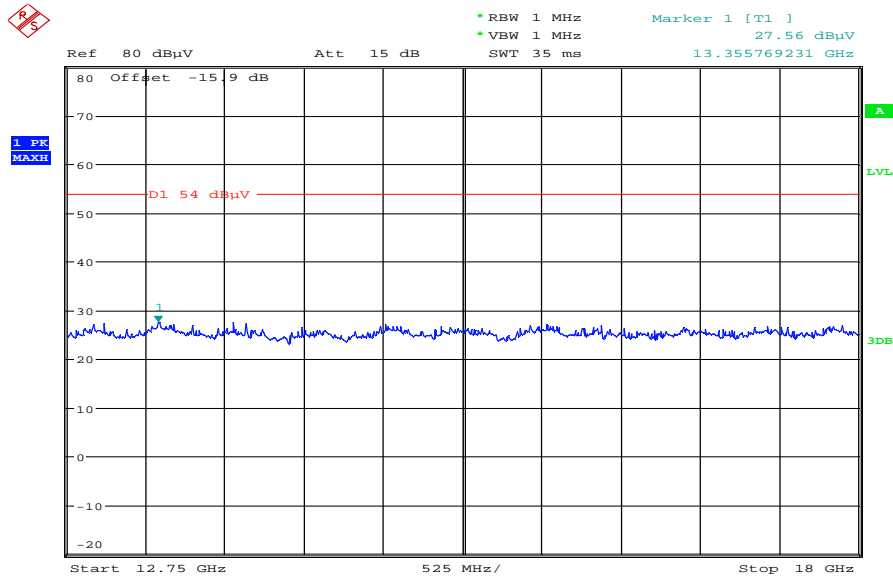

Date: 11.FEB.2011 09:28:24

Plot 15: Highest channel, 18 GHz to 26 GHz, vertical & horizontal polarization

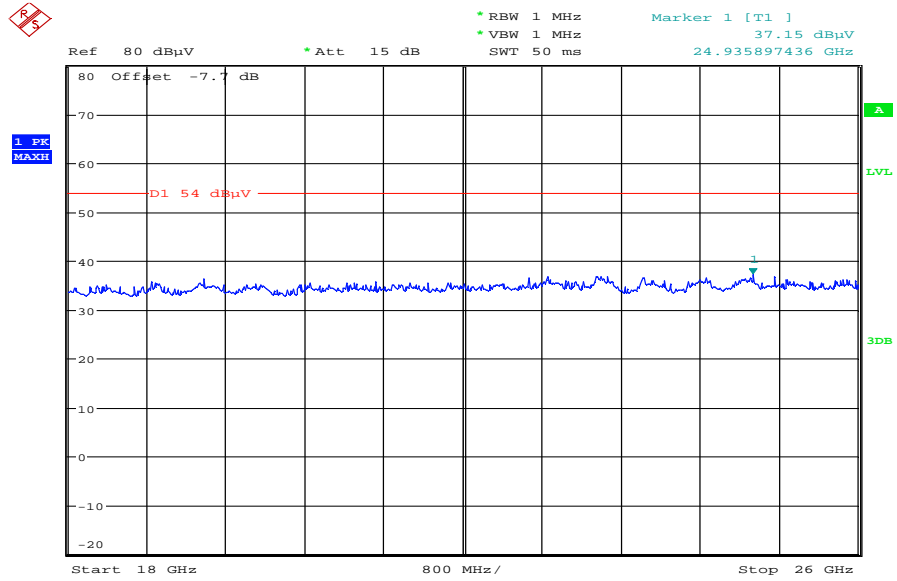

Date: 11.FEB.2011 09:56:15

## 9.11 RX spurious emissions radiated

### Description:

Measurement of the radiated spurious emissions in idle/receive mode. The results are valid for both modes.

### Measurement:

Measurement parameter	
Detector:	Peak / Quasi Peak
Sweep time:	Auto
Video bandwidth:	Sweep: 100 kHz Remeasurement: 10 Hz
Resolution bandwidth:	F < 1 GHz: 100 kHz F > 1 GHz: 1 MHz
Span:	30 MHz to 25 GHz
Trace-Mode:	Max Hold

### Limits:

FCC		IC
CFR Part 15.109		RSS Gen, Issue 2, 4.10
RX Spurious Emissions Radiated		
Frequency (MHz)	Field Strength (dB $\mu$ V/m)	Measurement distance
30 - 88	30.0	10
88 - 216	33.5	10
216 - 960	36.0	10
Above 960	54.0	3

### Results:

RX Spurious Emissions Radiated [dB $\mu$ V/m]		
F [MHz]	Detector	Level [dB $\mu$ V/m]
For emissions below 1 GHz, please take a look at the table below the 1 GHz plot.		
No emissions detected between 1 GHz and 12.75 GHz.		
For emissions above 12.75 GHz, please take a look at the plots.		
Measurement uncertainty	± 3 dB	

**Result:** The result of the measurement is passed.

**Plots: RX / Idle – mode**

**Plot 1:** 30 MHz to 1 GHz, vertical & horizontal polarization

**CETECOM ICT Services GmbH**

**Common Information**

EUT: AAD-3880088-BV  
 Serial Number:  
 Test Description: FCC Part 15  
 Operating Conditions: WLAN idle  
 Operator Name: LAN  
 Comment: AC 115V / 60 Hz

**Scan Setup: STAN\_Fin [EMI radiated]**

Hardware Setup: Electric Field (NOS)  
 Level Unit: dBµV/m

Subrange	Detectors	IF Bandwidth	Meas. Time	Receiver
30 MHz - 1,05 GHz	QuasiPeak	120 kHz	15 s	Receiver

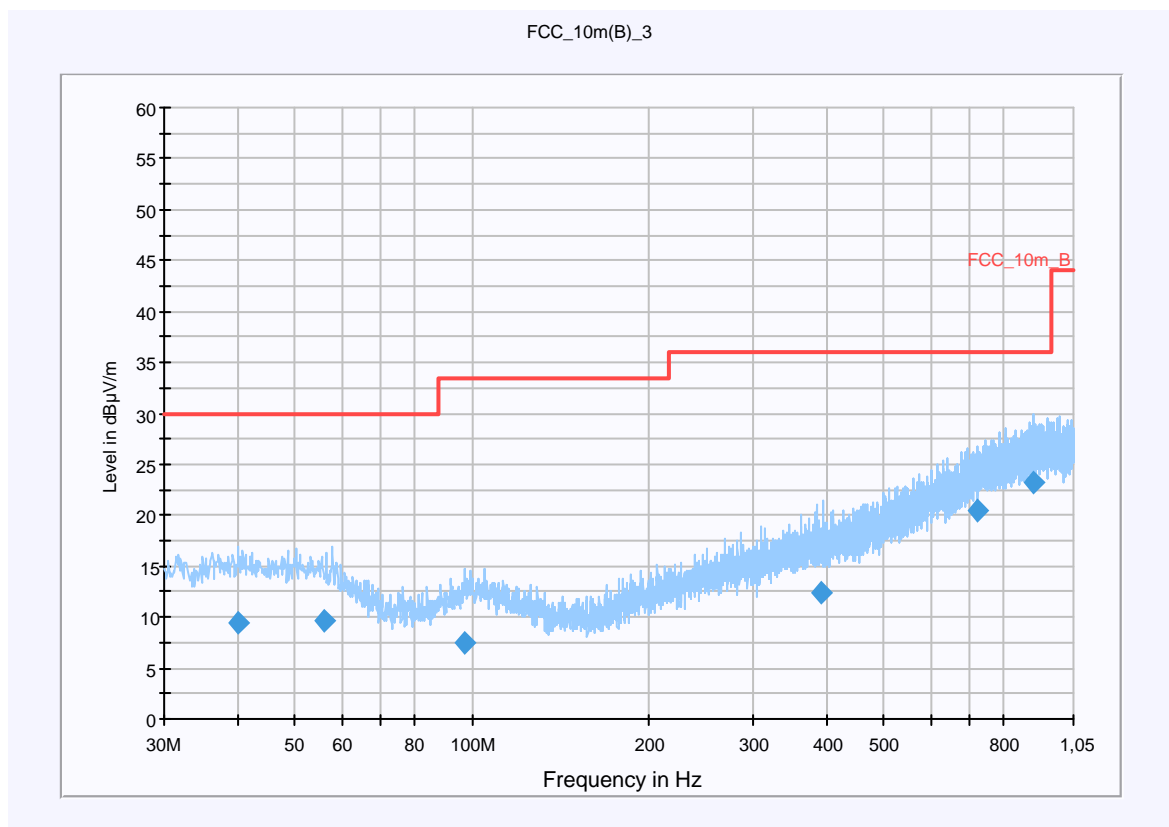

**Final Result 1**

Frequency (MHz)	QuasiPeak (dBµV/m)	Meas. Time (ms)	Bandwidth (kHz)	Antenna height (cm)	Polarity	Turntable position (deg)	Corr. (dB)	Margin (dB)	Limit (dBµV/m)	Comment
40.069350	9.5	15000.000	120.000	170.0	H	87.0	13.4	20.5	30.0	
56.030100	9.6	15000.000	120.000	220.0	V	34.0	12.6	20.4	30.0	
97.138050	7.5	15000.000	120.000	123.0	V	277.0	11.5	26.0	33.5	
392.681550	12.4	15000.000	120.000	220.0	V	158.0	16.8	23.6	36.0	
719.696550	20.4	15000.000	120.000	220.0	H	89.0	23.0	15.6	36.0	
895.994850	23.3	15000.000	120.000	121.0	V	49.0	25.1	12.7	36.0	

**Hardware Setup: EMI radiated\Electric Field (NOS) - [EMI radiated]**

Subrange 1	
Frequency Range:	30 MHz - 2 GHz
Receiver:	Receiver [ESCI 3] @ GPIB0 (ADR 20), SN 100083/003, FW 4.32
Signal Path:	without Notch FW 1.0
Antenna:	VULB 9163 SN 9163-295, FW --- Correction Table (vertical): VULP6113 Correction Table (horizontal): VULP6113 Correction Table: Cable_EN_1GHz (1005)
Antenna Tower:	Tower [EMCO 2090 Antenna Tower] @ GPIB0 (ADR 8), FW REV 3.12
Turntable:	Turntable [EMCO Turntable] @ GPIB0 (ADR 9), FW REV 3.12

EMC 32 Version 8.10.00

**Plot 2: 1 GHz to 12.75 GHz, vertical polarization**

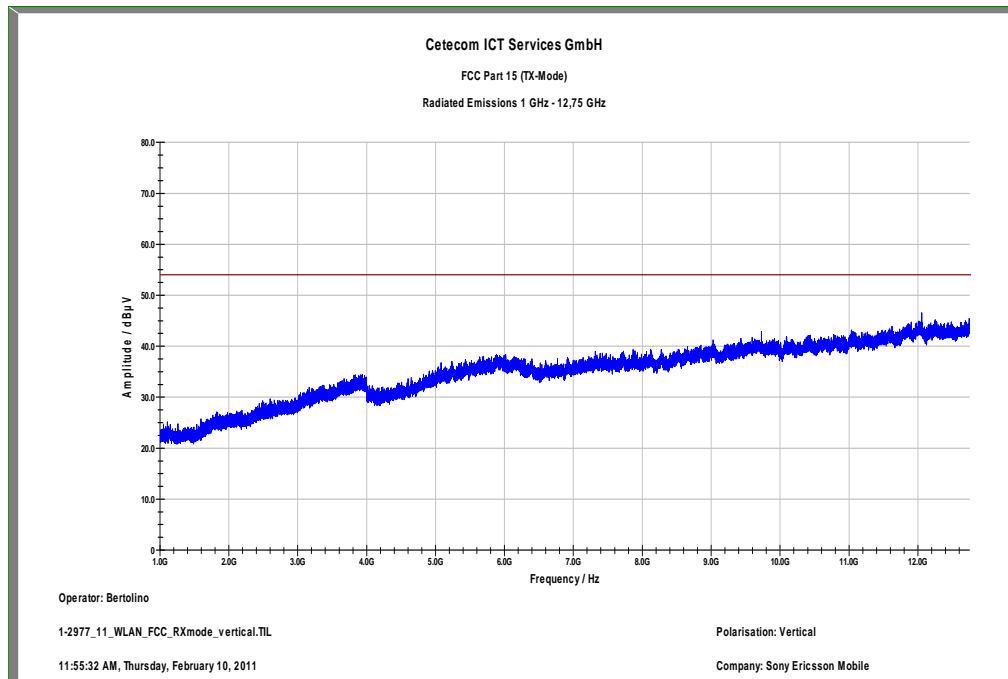

Plot 3: 1 GHz to 12.75 GHz, horizontal polarization

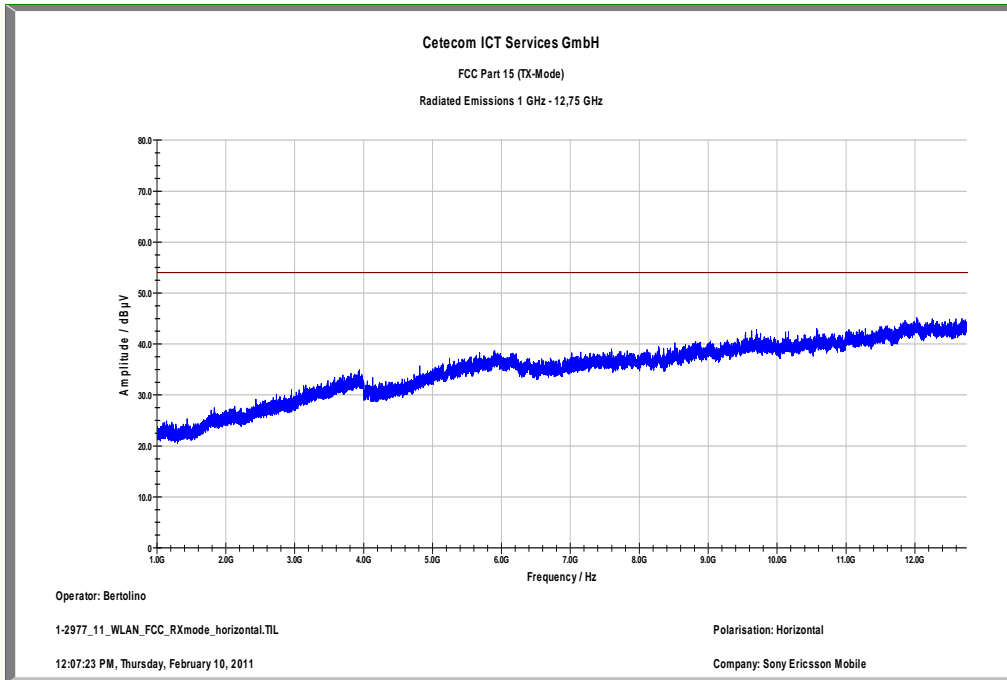

Plot 4: 12.75 GHz to 18 GHz, vertical & horizontal polarization

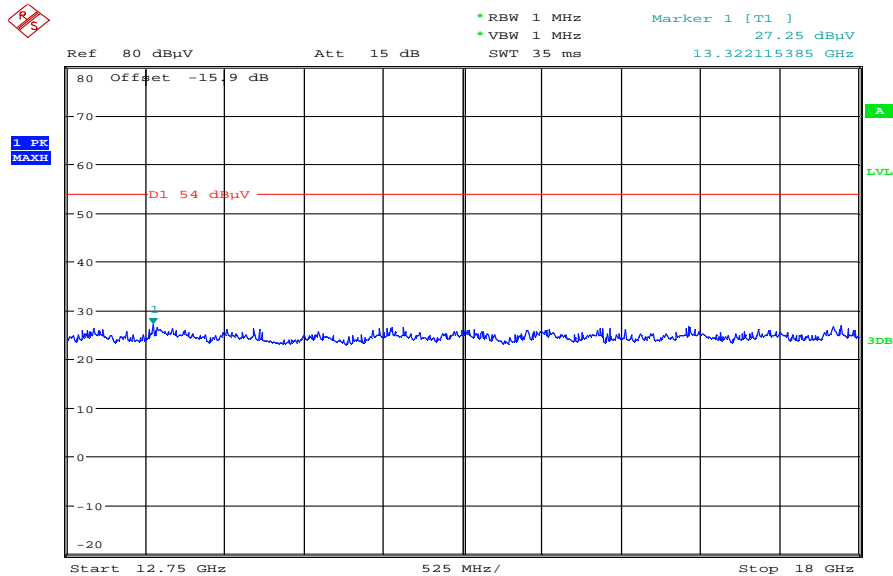

Plot 5: 18 GHz to 26 GHz, vertical & horizontal polarization

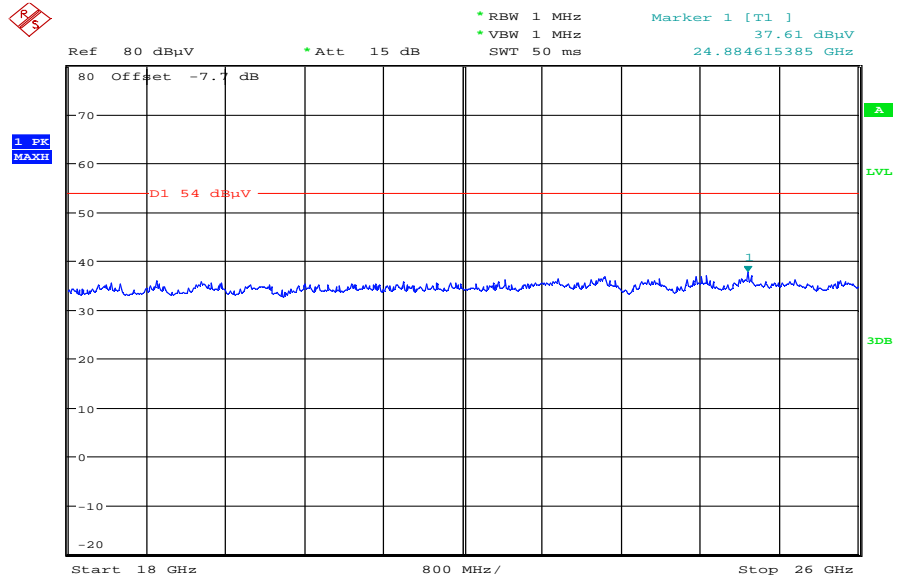

Date: 11.FEB.2011 09:45:28



## 9.12 TX spurious emissions radiated < 30 MHz

### Description:

Measurement of the radiated spurious emissions in transmit mode below 30 MHz. The EUT is set to channel 6. This measurement is representative for all channels and modes. If critical peaks are found channel 1 and channel 11 will be measured too. The measurement is performed with the data rate producing the highest output power. The limits are recalculated to a measurement distance of 3 m with 40 dB/decade according CFR Part 2.

### Measurement:

Measurement parameter	
Detector:	Peak / Quasi Peak
Sweep time:	Auto
Video bandwidth:	F < 150 kHz: 200 Hz F > 150 kHz: 9 kHz
Resolution bandwidth:	F < 150 kHz: 1 kHz F > 150 kHz: 100 kHz
Span:	9 kHz to 30 MHz
Trace-Mode:	Max Hold

### Limits:

FCC		IC	
CFR Part 15.209(a)		RSS –Gen	
TX Spurious Emissions Radiated < 30 MHz			
Frequency (MHz)	Field Strength (dB $\mu$ V/m)	Measurement distance	
0.009 – 0.490	2400/F(kHz)	300	
0.490 – 1.705	24000/F(kHz)	30	
1.705 – 30.0	30	30	

### Results:

TX Spurious Emissions Radiated < 30 MHz [dB $\mu$ V/m]		
F [MHz]	Detector	Level [dB $\mu$ V/m]
No critical peaks detected.		
Measurement uncertainty	± 3 dB	

**Result:** The result of the measurement is passed.

**Plots: DSSS / b – mode**

**Plot 1: Lowest channel, 9 kHz to 30 MHz**

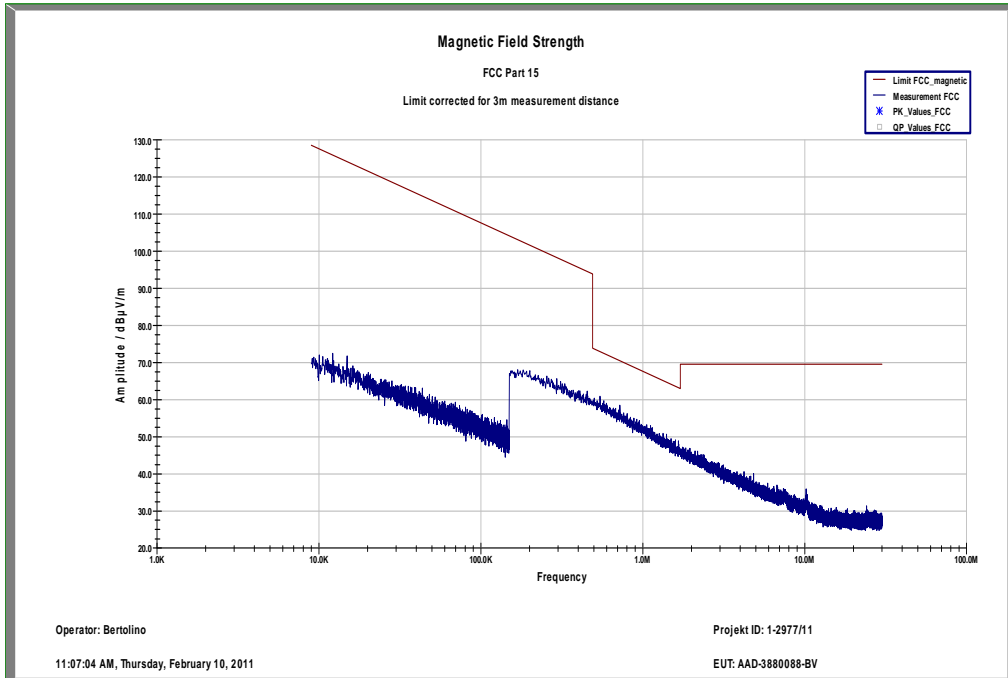

**Plot 2: Middle channel, 9 kHz to 30 MHz**

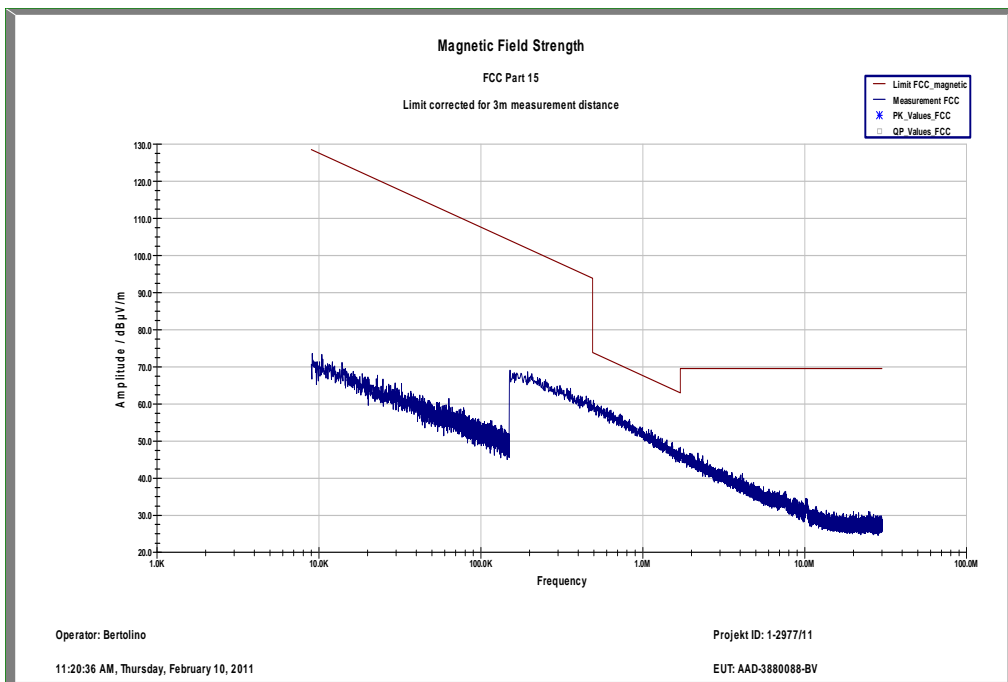

Plot 3: Highest channel, 9 kHz to 30 MHz

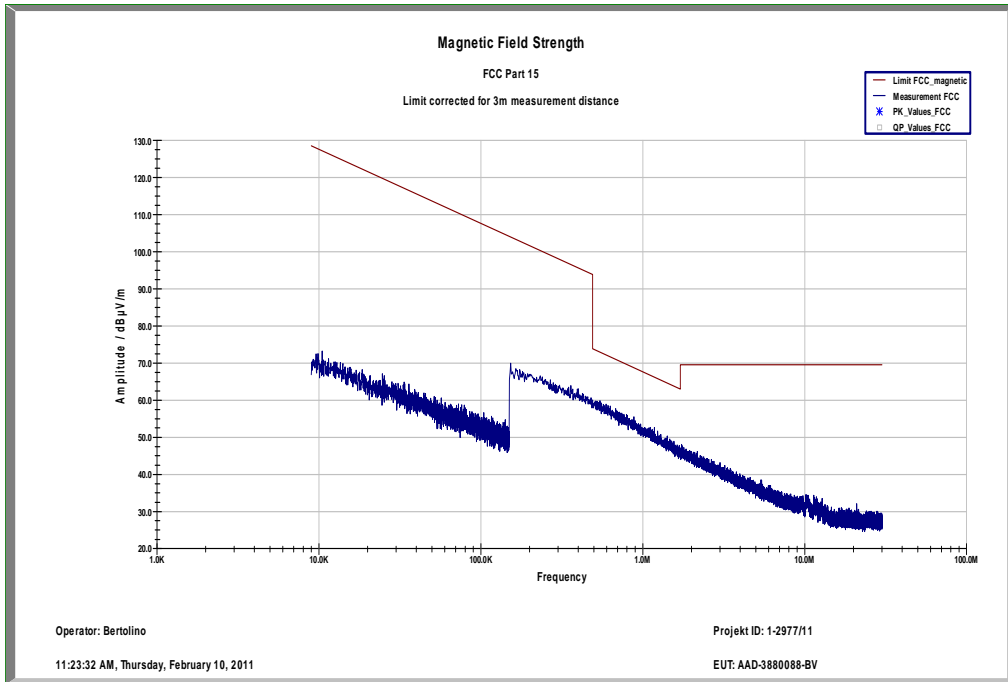

**Plots: OFDM / g – mode**

Plot 1: Lowest channel, 9 kHz to 30 MHz

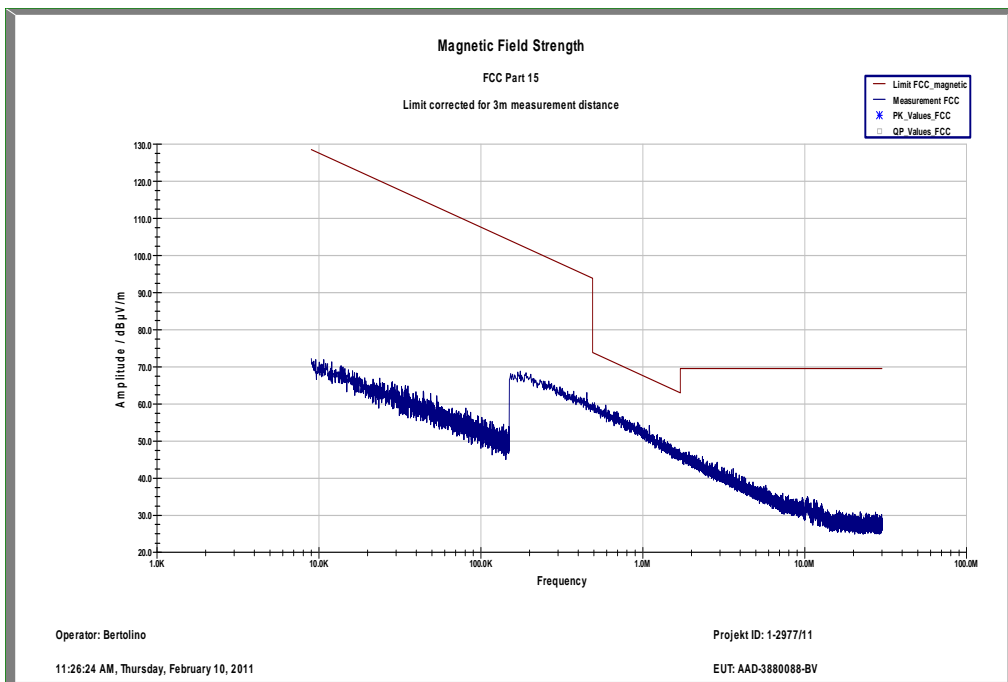

Plot 2: Middle channel, 9 kHz to 30 MHz

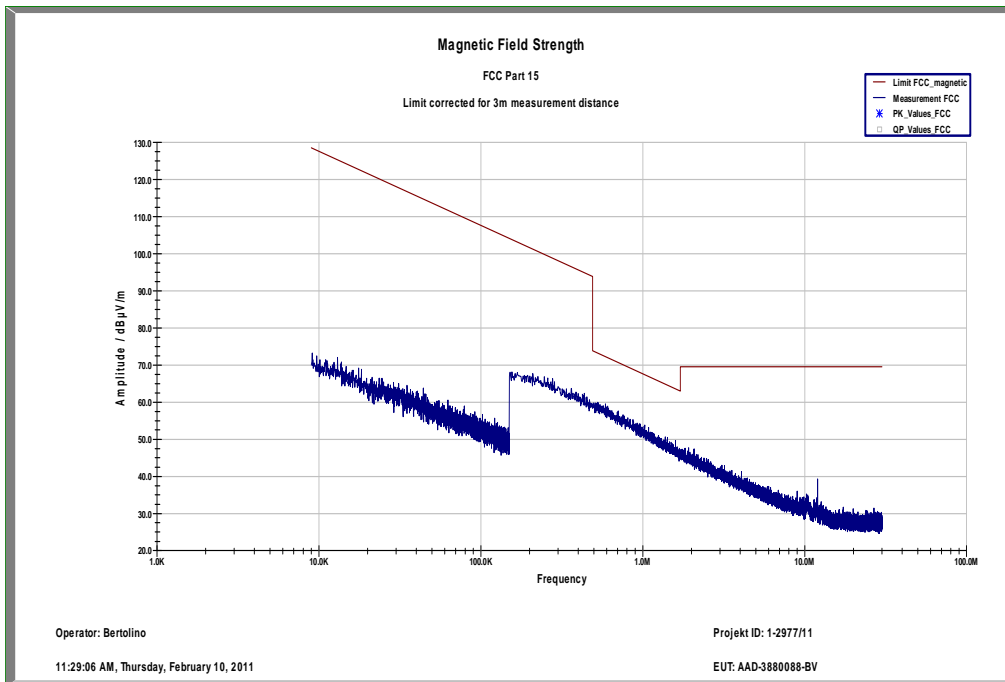

Plot 3: Highest channel, 9 kHz to 30 MHz

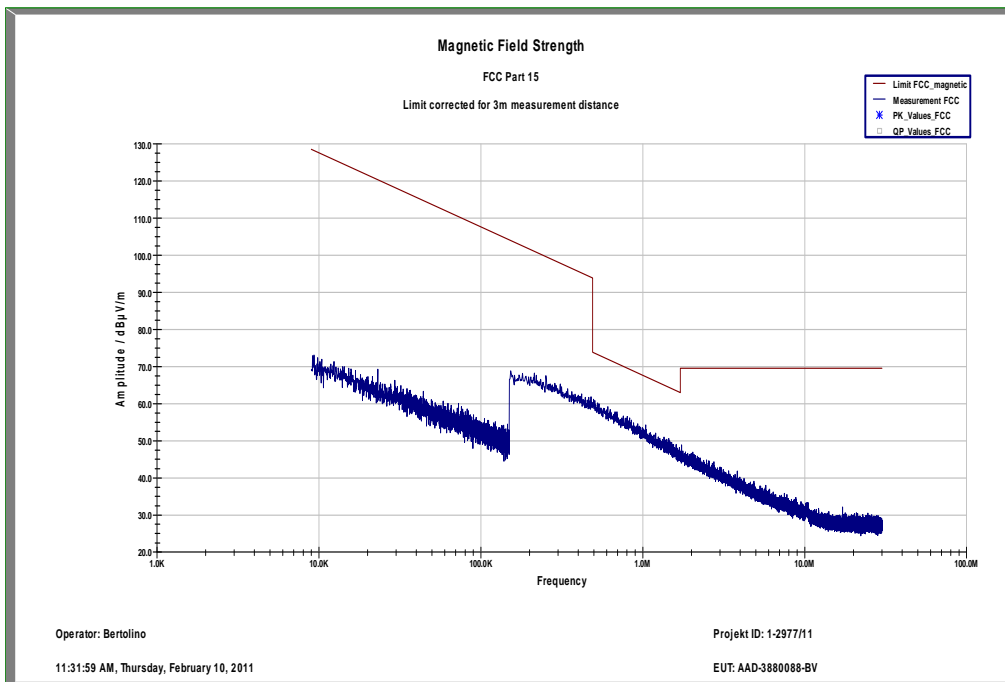

**Plots: OFDM / n – mode**

**Plot 1: Lowest channel, 9 kHz to 30 MHz**

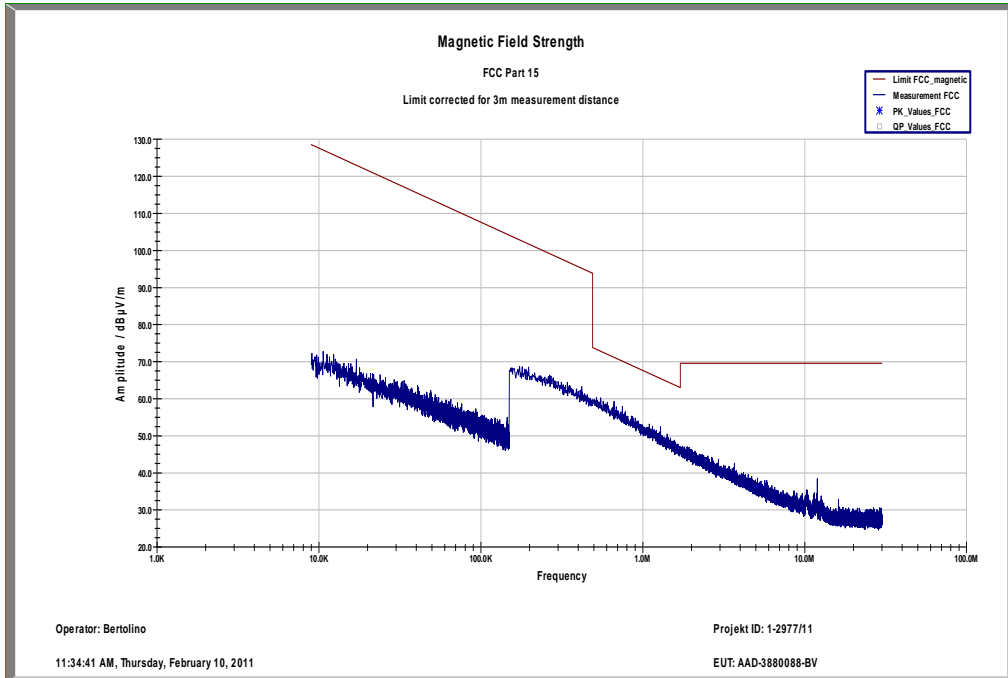

**Plot 2: Middle channel, 9 kHz to 30 MHz**

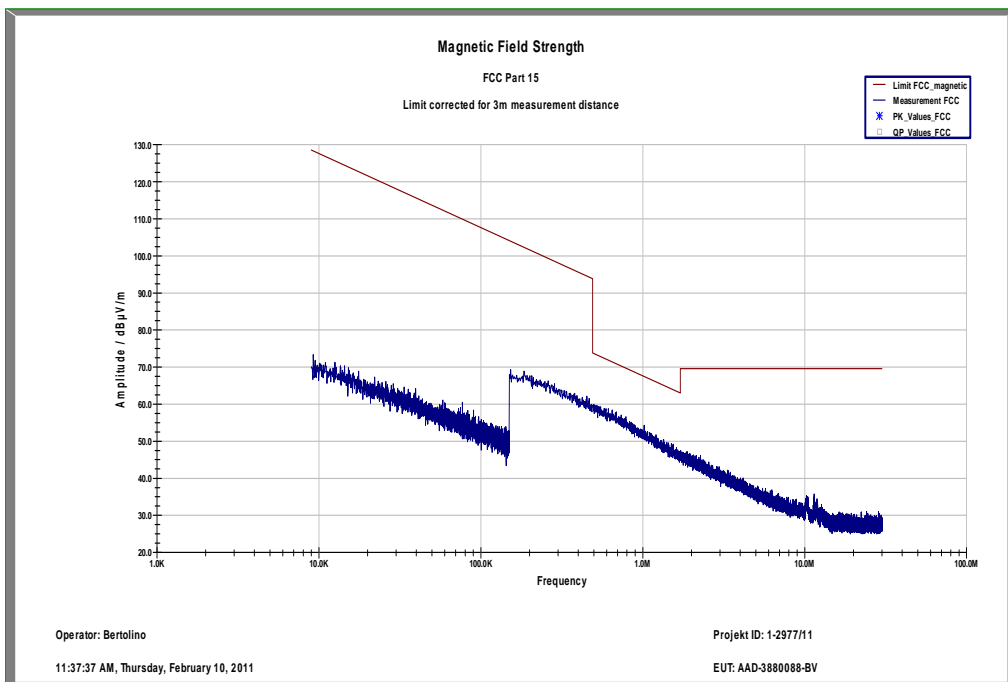

Plot 3: Highest channel, 9 kHz to 30 MHz

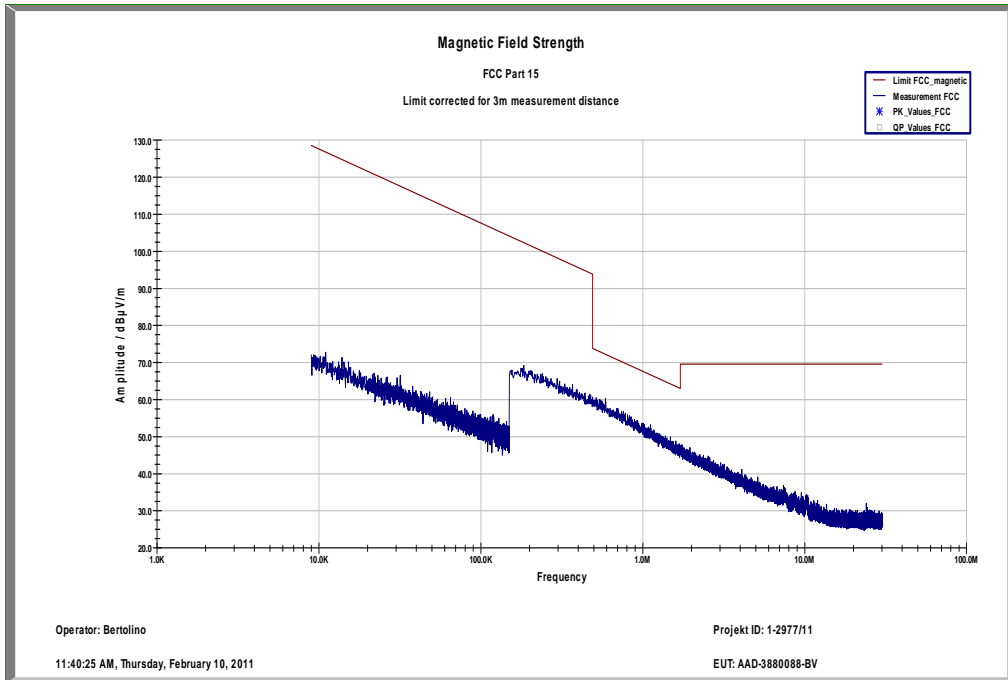

**Plots: RX / Idle – mode**

Plot 1: 9 kHz to 30 MHz

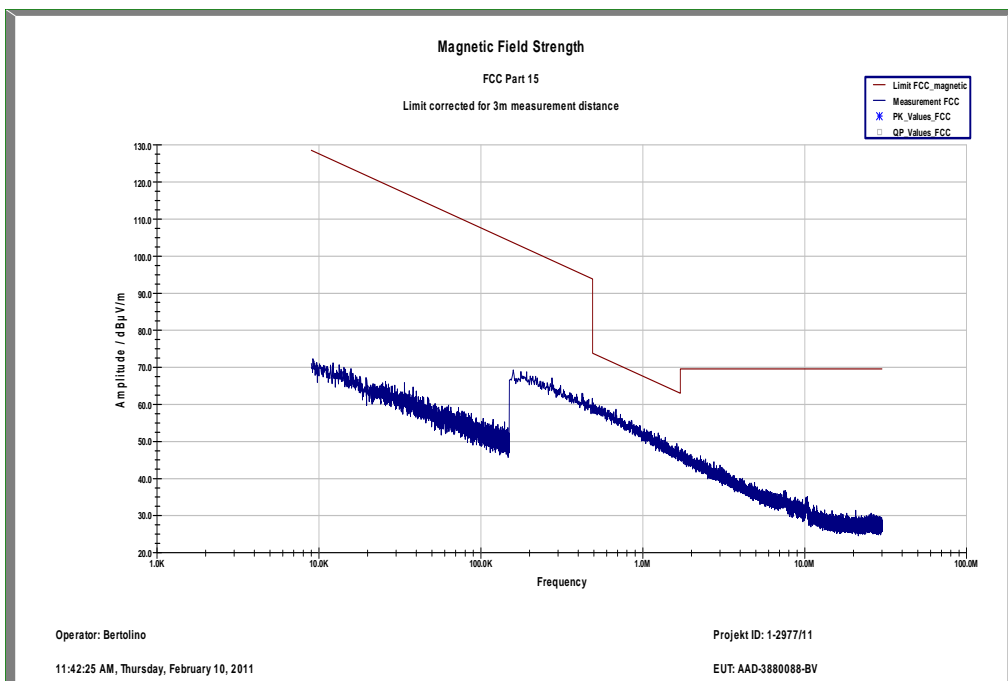

### 9.13 TX spurious emissions conducted < 30 MHz

**Description:**

Measurement of the conducted spurious emissions in transmit mode below 30 MHz. The EUT is set to channel 6. This measurement is repeated for DSSS and OFDM modulation. If critical peaks are found channel 1 and channel 11 will be measured too. The measurement is performed with the data rate producing the highest output power. Both power lines, phase and neutral line, are measured. Found peaks are remeasured with average and quasi peak detection to show compliance to the limits.

**Measurement:**

Measurement parameter	
Detector:	Peak - Quasi Peak / Average
Sweep time:	Auto
Video bandwidth:	F < 150 kHz: 200 Hz F > 150 kHz: 9 kHz
Resolution bandwidth:	F < 150 kHz: 1 kHz F > 150 kHz: 100 kHz
Span:	9 kHz to 30 MHz
Trace-Mode:	Max Hold

**Limits:**

FCC		IC	
CFR Part 15.107(a)		ICES-003, Issue 4	
TX Spurious Emissions Conducted < 30 MHz			
Frequency (MHz)	Quasi-Peak (dBµV/m)	Average (dBµV/m)	
0.15 – 0.5	66 to 56*	56 to 46*	
0.5 – 5	56	46	
5 – 30.0	60	50	

\*Decreases with the logarithm of the frequency

**Results:**

TX Spurious Emissions Conducted < 30 MHz [dBµV/m]		
F [MHz]	Detector	Level [dBµV/m]
No critical peaks detected.		
Measurement uncertainty	± 3 dB	

**Result:** The result of the measurement is passed.

**Plots:**

**Plot 1:** DSSS / b – mode, 9 kHz to 30 MHz, phase line

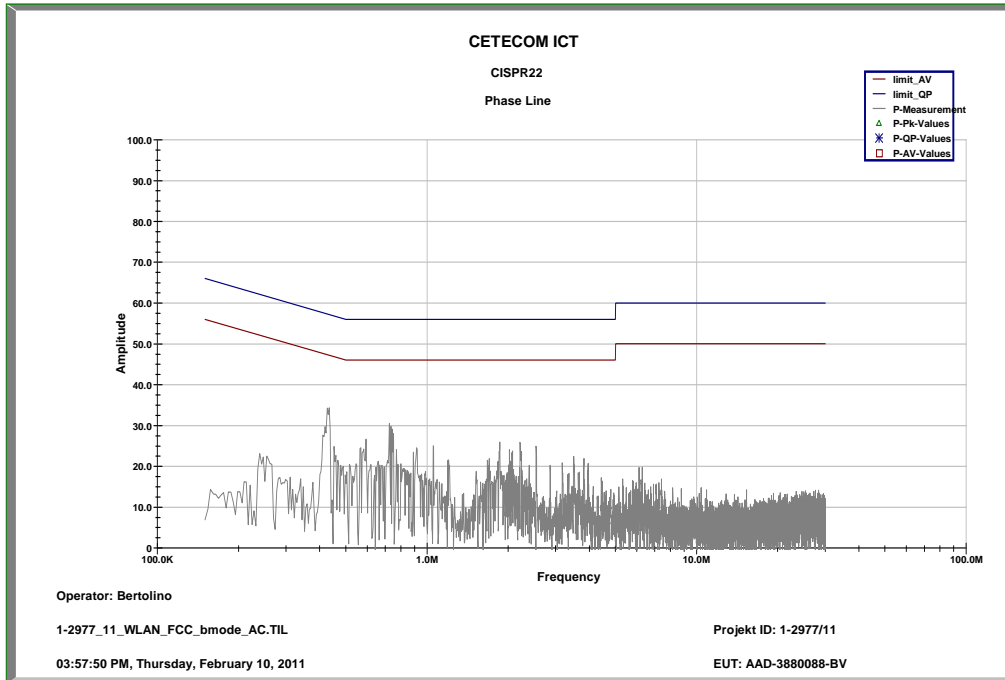

**Plot 2:** DSSS / b – mode, 9 kHz to 30 MHz, neutral line

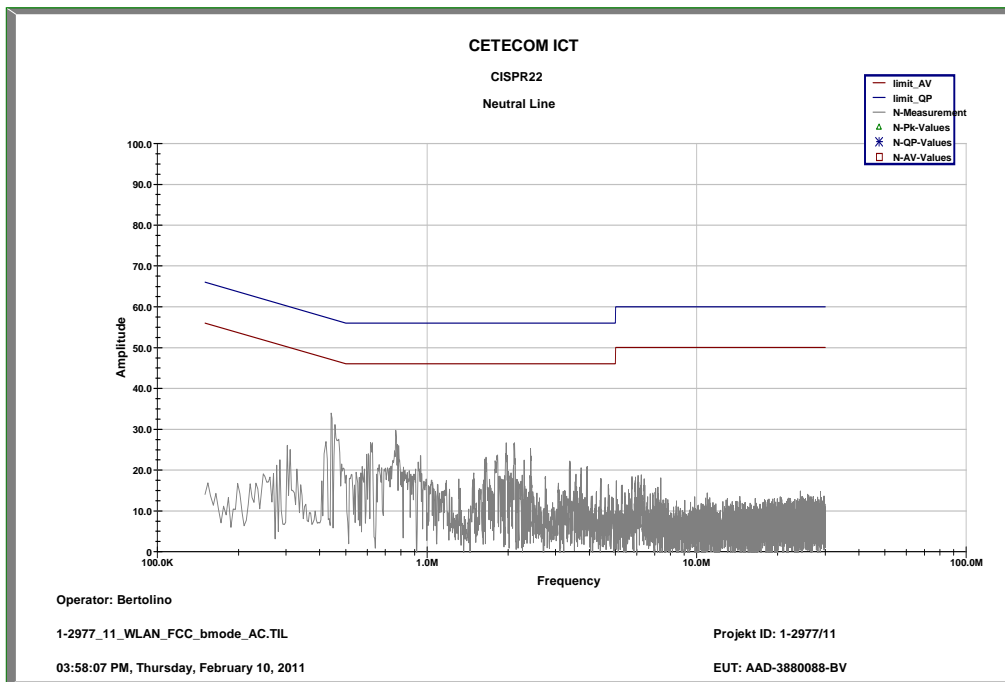



Plot 3: OFDM / g – mode, 9 kHz to 30 MHz, phase line

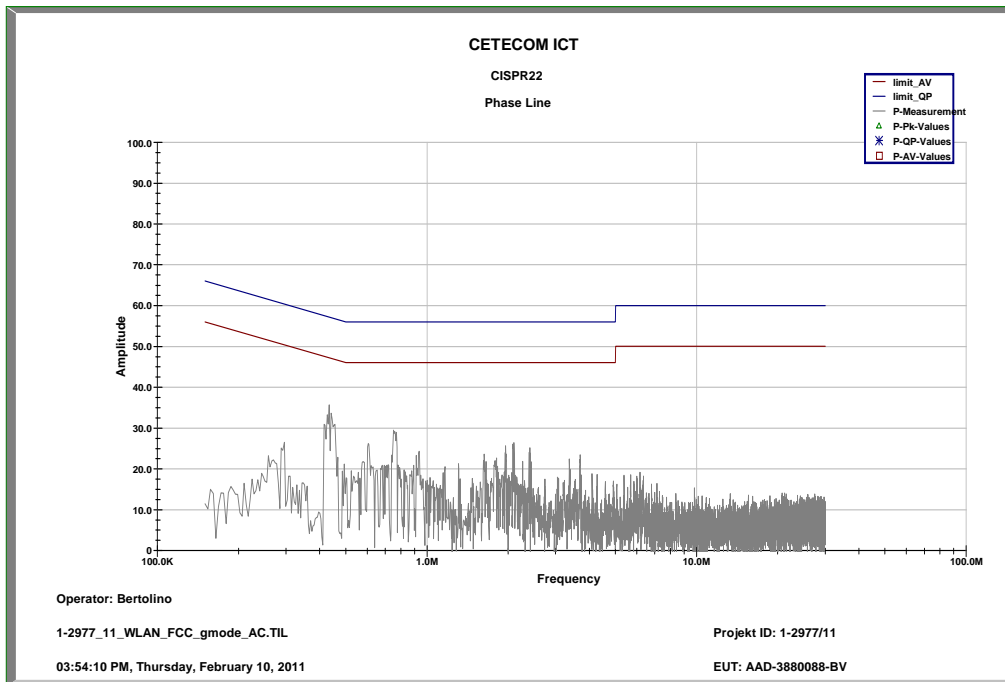

Plot 4: OFDM / g – mode, 9 kHz to 30 MHz, neutral line

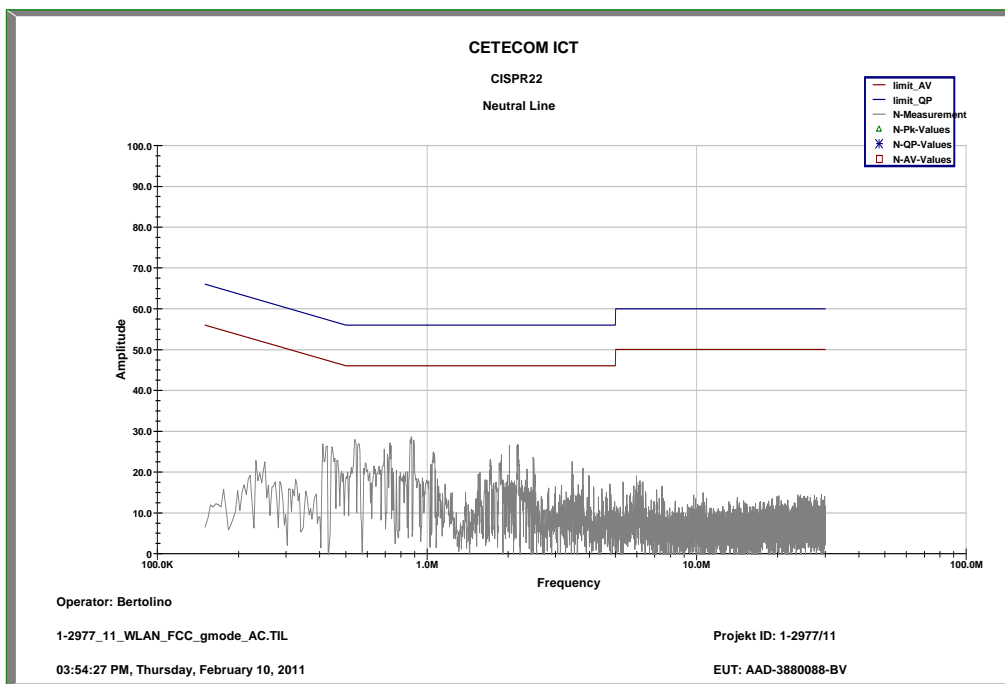

Plot 5: OFDM / n – mode, 9 kHz to 30 MHz, phase line

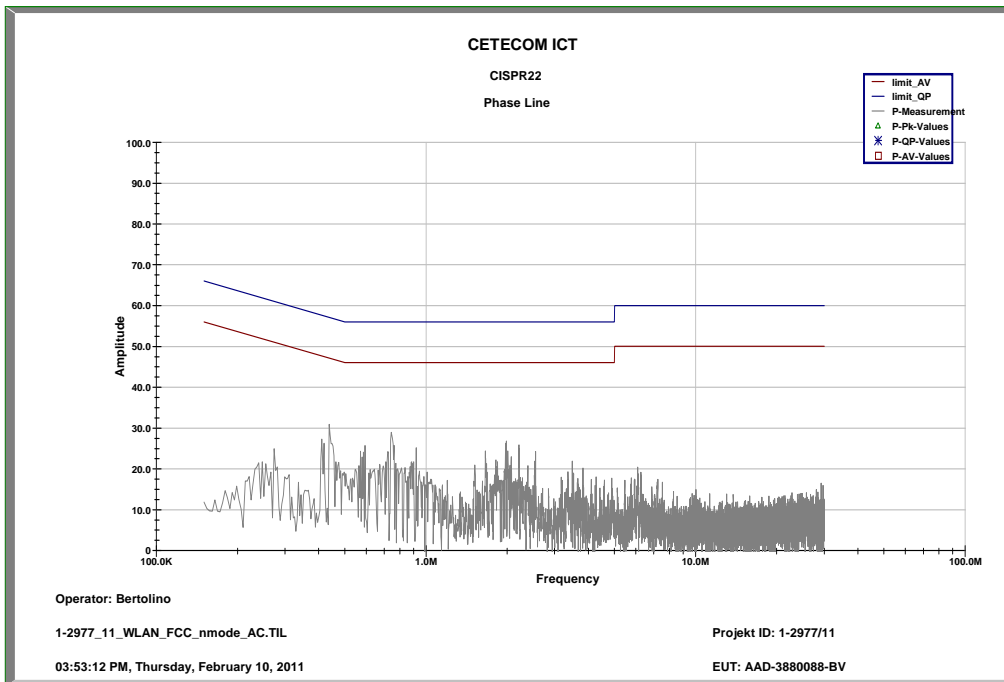

Plot 6: OFDM / n – mode, 9 kHz to 30 MHz, neutral line

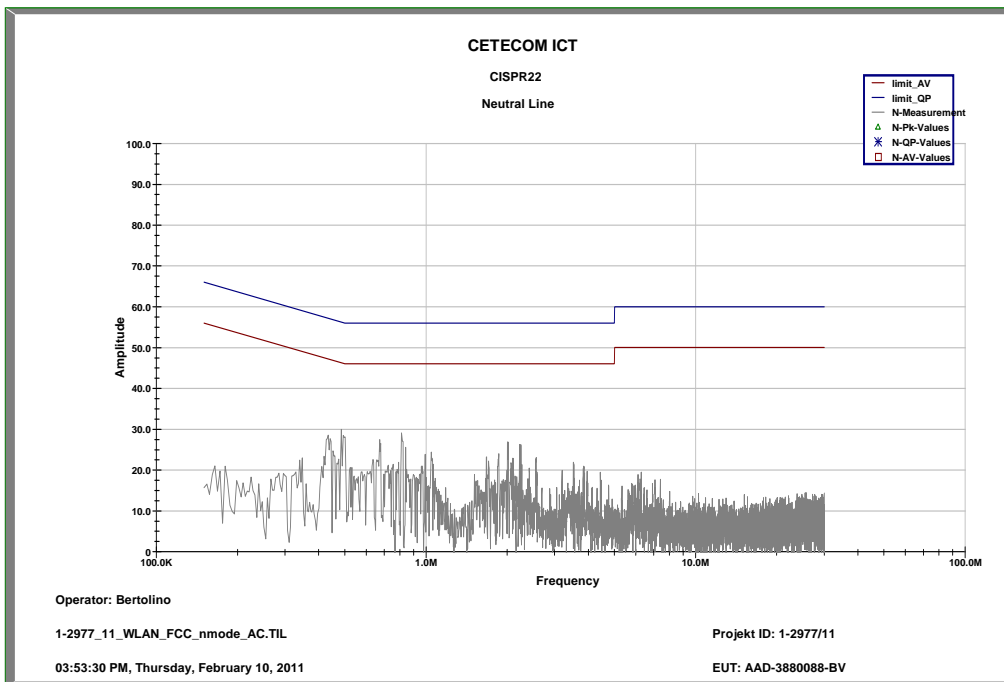

Plot 7: RX / Idle – mode, 9 kHz to 30 MHz, phase line

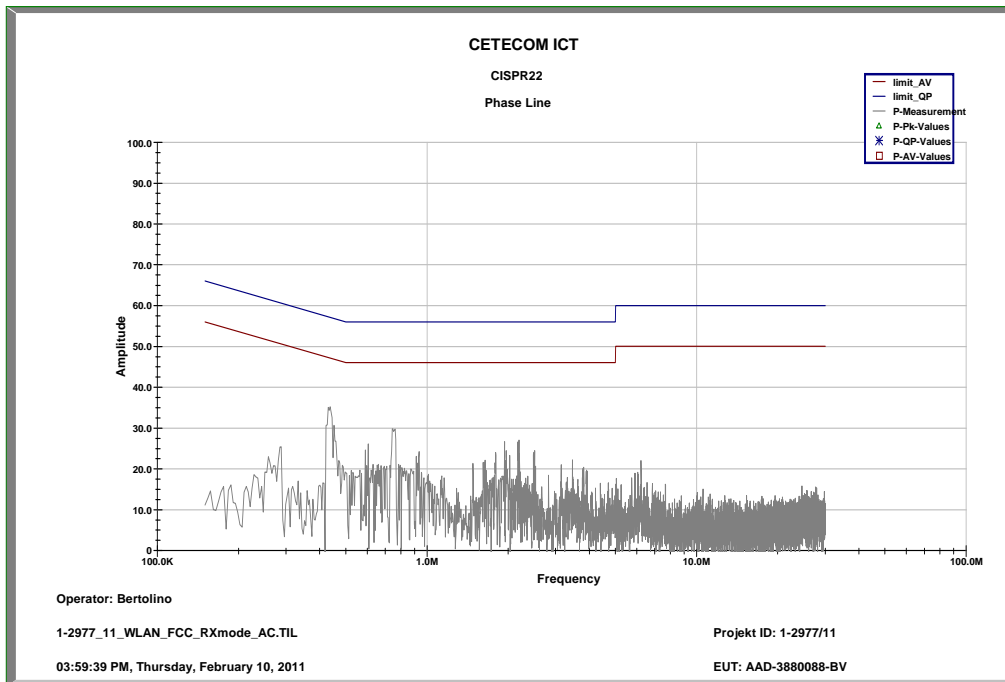

Plot 8: RX / Idle – mode, 9 kHz to 30 MHz, neutral line

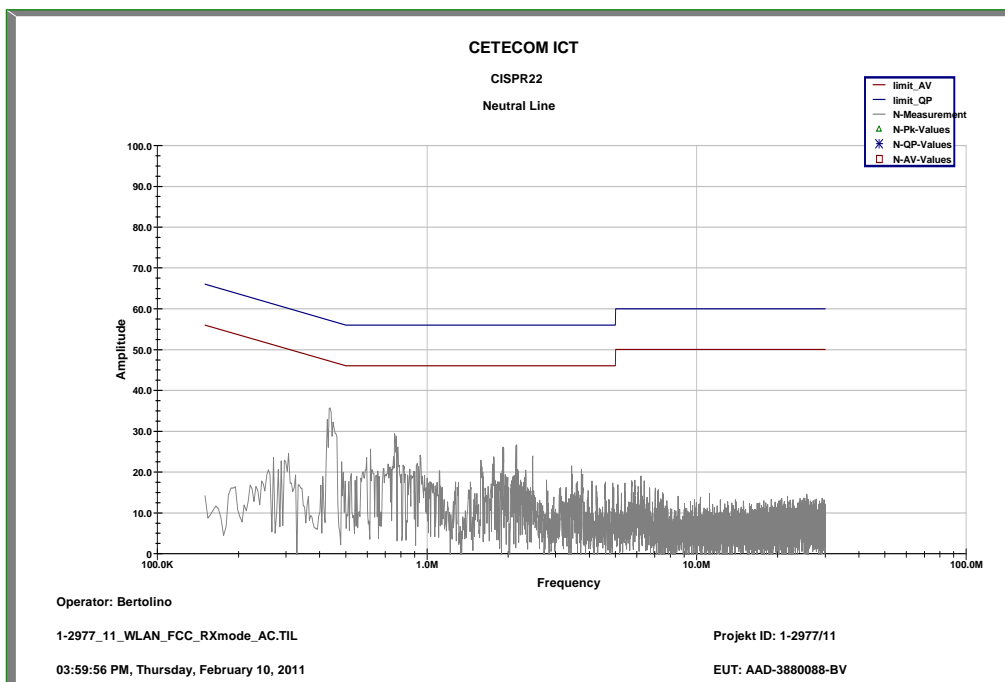

## 10 Test equipment and ancillaries used for tests

Typically, the calibrations of the test apparatus are commissioned to and performed by an accredited calibration laboratory. The calibration intervals are determined in accordance with the DIN EN ISO/IEC 17025. In addition to the external calibrations, the laboratory executes comparison measurements with other calibrated test systems or effective verifications. Weekly chamber inspections and range calibrations are performed. Where possible, rf-generating and signalling equipment as well as measuring receivers and analyzers are connected to an external high-precision 10 MHz reference (GPS-based or rubidium frequency standard).

In order to simplify the identification of the equipment used at some special tests, some items of test equipment and ancillaries can be provided with an identifier or number in the equipment list below (Labor/Item).

No.	Lab / Item	Equipment	Type	Manufact.	Serial No.	INV. No Cetecom	Kind of Calibration	Last Calibration	Next Calibration
1	45	Switch-Unit	3488A	HP Meßtechnik	2719A14505	300000368	g		
2	n. a.	software	SPS_PHE 1.4f	Spitzberger & Spieß	B5981; 5D1081;B5979	300000210	ne		
3	n. a.	EMI Test Receiver	ESCI 1166.5950.03	R&S	100083	300003312	k	08.01.2010	08.01.2012
4	n. a.	Amplifier	JS42-00502650- 28-5A	MITEQ	1084532	300003379	ev		
5	n. a.	Antenna Tower	Model 2175	ETS- LINDGREN	64762	300003745	izw		
6	n. a.	Positioning Controller	Model 2090	ETS- LINDGREN	64672	300003746	izw		
7	n. a.	Turntable Interface-Box	Model 105637	ETS- LINDGREN	44583	300003747	izw		
8	n. a.	TRILOG Broadband Test-Antenna 30 MHz - 3 GHz	VULB9163	Schwarzbeck	295	300003787	k	01.04.2010	01.04.2012
9	n. a.	Spectrum-Analyzer	FSU26	R&S	200809	300003874	k	08.01.2010	08.01.2012
10	n. a.	Isolating Transformer	RT5A	Grundig	8041	300001626	g		
11	n. a.	PowerAttenuator	8325	Byrd	1530	300001595	ev		
12	n. a.	Double-Ridged Waveguide Horn Antenna 1- 18.0GHz	3115	EMCO	8812-3088	300001032	viKI!	05.03.2009	05.03.2011
13	n. a.	Active Loop Antenna	6502	EMCO	2210	300001015	ne		
14	n. a.	Anechoic chamber	FAC 3/5m	MWB / TDK	87400/02	300000996		23.03.2009	
15	n. a.	Relais Matrix	3488A	HP Meßtechnik	2719A15013	300001156	ne		
16	n. a.	Relais Matrix	PSU	R&S	890167/024	300001168	ne		
17	n. a.	Three-Way Power Splitter, 50 Ohm	11850C	HP Meßtechnik		300000997	ne		
18	n. a.	Amplifier	js42-00502650- 28-5a	Parzich GMBH	928979	300003143	ne		
19	n. a.	Band Reject filter	WRCG2400/2483- 2375/2505- 50/10SS	Wainwright	11	300003351	ev		
20	n. a.	TILE-Software Emission	Quantum Change, Modell TILE- ICS/FULL	EMCO	none	300003451	ne		
21	n. a.	PSA Spectrum Analyzer 3 Hz - 26.5 GHz	E4440A	Agilent Technologies	MY48250080	300003812	k	08.09.2010	08.09.2012
22	n. a.	RF Filter Section 9kHz - 1GHz	N9039A	Agilent Technologies	MY48260003	300003825	viKI!	08.09.2010	08.09.2012
23	n. a.	TRILOG Broadband Test-Antenna 30 MHz - 3 GHz	VULB9163	Schwarzbeck	371	300003854	viKI!	17.12.2008	17.12.2011
24	A026	Std. Gain Horn Antenna 12.4 to 18.0 GHz	639	Narda		300000787	ne		
25	A029	Std. Gain Horn Antenna 18.0 to 26.5 GHz	638	Narda		300002442	ne		
26	n. a.	Spectrum	FSU50	R&S	200012	300003443	ve	01.07.2010	01.07.2012

		Analyzer 20 Hz - 50 GHz							
27	n. a.	Spectrum Analyzer 9kHz to 30GHz - 140...+30dBm	FSP30	R&S	100886	300003575	k	07.09.2010	07.09.2012
28	11b	Microwave System Amplifier, 0.5-26.5 GHz; 25 dB gain	83017A	HP Meßtechnik	3123A00105	300002268	ev		

**Agenda:** Kind of Calibration

- |      |  |     |  |
|------|--|-----|--|
| k    | calibration / calibrated                   | EK  | limited calibration                                  |
| ne   | not required (k, ev, izw, zw not required) | zw  | cyclical maintenance (external cyclical maintenance) |
| ev   | periodic self verification                 | izw | internal cyclical maintenance                        |
| Ve   | long-term stability recognized             | g   | blocked for accredited testing                       |
| vkI! | Attention: extended calibration interval   |     |  |
| NK!  | Attention: not calibrated                  | *)  | next calibration ordered / currently in progress     |