

User guide

Please read the **Important information** before you use your mobile phone.

Experience more. Discover how.

Fill it with pop and let it rock. Share your life in pictures. Or why not go online for the latest updates? Your new phone is the key to a wider world. And it's just around the corner. Get started with this User guide. And join us online to get the full picture. Music, games, apps, updates, downloads, support and more. All in one place:
www.sonyericsson.com/Yari
www.sonyericsson.com/Aino

⚡ **Don't forget** to update your phone software. See *Updating your phone* on page 28.

User guide in the phone

An extended User guide is available in your phone.

To access the **User guide in your phone**

- Select **Menu** > **Settings** > **User help** > **User guide**.

Getting started

Assembly

Before you start using your phone, you need to insert a SIM card and the battery.

To insert the SIM card



- 1 Remove the battery cover.
- 2 Slide the SIM card into its holder with the gold-coloured contacts facing down.

To insert the battery

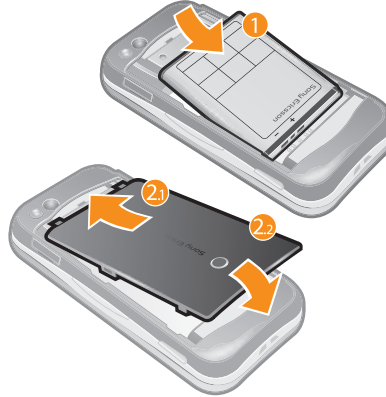

- 1 Insert the battery with the label side up and the connectors facing each other.
- 2 Attach the battery cover.

Phone overview

- 1 Ear speaker
- 2 Video call camera
- 3 Gaming keys
- 4 Screen
- 5 Connector for charger, handsfree and USB cable
- 6 Selection keys
- 7 Call key
- 8 Activity menu key
- 9 Navigation key
- 10 End key, On/off key
- 11 C key (Clear)

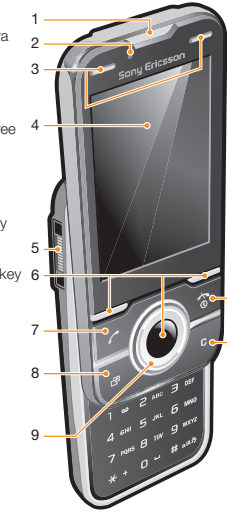

- 12 Main camera
- 13 Flash light
- 14 Memory card slot
- 15 Volume, digital zoom key
- 16 Stereo speakers
- 17 Camera key
- 18 Antenna
- 19 Strap hole

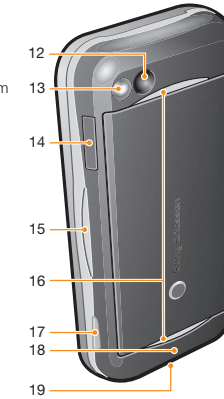

Turning on the phone

To turn on the phone



- 1 Press and hold down (1).
 - 2 Enter your SIM card PIN (Personal Identification Number), if requested, and select **OK**.
 - 3 Select a language.
 - 4 Follow the instructions that appear.
- ⚡ If you want to correct a mistake when you enter your PIN, press (C).

More information

In addition to this User guide, Feature guides and more information are available at www.sonyericsson.com/support.

Yari™ phone

To view tips and tricks

- Select **Menu** > **Settings** > **User help** > **Tips and tricks**.

To view information about functions

- Scroll to a function and select **Info**. If available. In some cases, **Info** appears under **Options**.

To view the phone status

- Press the volume key. Phone, memory and battery information is shown.

Supported services and features

- Some of the services and features described in this User guide are not supported by all networks and/or service providers in all areas. Without limitation, this applies to the GSM International Emergency Number 112. Please contact your network operator or service provider to determine availability of any specific service or feature and whether additional access or usage fees apply.

Charging the battery

The phone battery is partly charged when you buy it.

To charge the battery



- 1 Connect the charger to the phone.
- 2 Remove the charger by tilting the plug upwards.

Maximising battery performance

- Charge your phone often. The battery lasts longer if you charge it frequently.
- If you are in an area with no coverage, your phone repeatedly scans for available networks. This consumes power. If you cannot move to an area with better coverage, turn off your phone temporarily.
- Turn off 3G, Bluetooth™ wireless technology and Wi-Fi™ when you do not need these functions.
- Do not cover the phone antenna when you are engaged in a call.

Navigation

To access the main menu

- When **Menu** appears on the screen, press the centre selection key to select **Menu**.
- If **Menu** does not appear on the screen, press (M) and then press the centre selection key to select **Menu**.

To navigate the phone menus



- Press the navigation key upwards, downwards, left or right to move through the menus.

To end a function

- Press (M).

To return to standby

- Press (M).

To delete items

- Press (C) to delete items such as numbers, letters, pictures and sounds.

Shortcuts

You can use the navigation key shortcuts to go directly to functions from standby.

To use navigation key shortcuts

- Press the navigation key upwards, downwards, left or right, to go directly to a function.

To edit a navigation key shortcut

- 1 Select **Menu** > **Settings** > **General** > **Shortcuts**.
- 2 Scroll to an option and select **Edit**.
- 3 Scroll to a menu option and select **Shortc...**

Activity menu

The activity menu gives you quick access to:

- **New events** – missed calls and new messages.
- **Running apps** – applications that are running in the background.
- **My shortcuts** – add your favourite functions to access them quickly.
- **Internet** – connect conveniently to the Internet.

To open the activity menu

- Press (M).

Memory card

- ⚡ You may have to purchase a memory card separately.

Your phone supports a microSD™ memory card adding more storage space to your phone. It can also be used as a portable memory card with other compatible devices. You can move content between a memory card and the phone memory.

To insert a memory card



- Open the cover and insert a memory card with the gold-coloured contacts facing down.

To remove a memory card

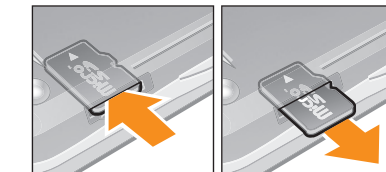

- Open the cover and press the edge of the memory card to release and remove it.

Entering text

You can use multitap text input or Quick text input to enter text. The Quick text input method uses a dictionary application in your phone.

To change the writing language

- When you enter text, press and hold down (L) to change to Quick text input.

To change the text input method

- When you enter text, press and hold down (M) to change to Quick text input.

To shift between upper- and lower-case letters or numbers

- When you enter text, press (N) repeatedly until the desired letter appears.

To enter numbers

- 1 When you enter text, press (O) until (P) appears at the top of the screen.

2 To enter a number, press (Q) – (S).

- To enter a number from text input mode, you can press and hold down (Q) – (S).

To enter punctuation marks and symbols

- 1 When you enter text, press (T) briefly.
- 2 Scroll to a symbol and select **Insert**.

- To select from the most commonly used punctuation marks, you can also press (U).

To enter text using Quick text input

- 1 Select, for example, **Menu** > **Messaging** > **Write new** > **Message**.

- 2 If (V) is not displayed, press and hold down (W) to change to Quick text input.

- 3 Press each key only once, even if the letter you want is not the first letter on the key. For example, to write the word "Jane", press (X), (Y), (Z), (A). Write the whole word before looking at the suggestions.

- 4 To view word suggestions, press (B) or press the navigation key downwards.

- 5 Press (C) to accept a suggestion and add a space.

To enter text using the multitap method

- 1 Select, for example, **Menu** > **Messaging** > **Write new** > **Message**.

- 2 If (V) is displayed, press and hold down (W) to change to multitap text input.

- 3 Press (Z) – (A) repeatedly until the desired letter appears.

- 4 Press (C) to add a space.

To add words to the phone dictionary

- 1 When you enter text using Quick text input, select **Options** > **Spell word**.
- 2 Write the word using multitap input and select **Save**.

Calling

You need to turn on your phone and be within range of a network.

Making and answering calls

To make a call

- 1 Enter a phone number (with international country code and area code, if applicable).
- 2 Press (M).

- You can call numbers from your contacts and call list.

To end a call

- Press (M).

To make international calls

- 1 Press and hold down (N) until a "+" sign appears.
- 2 Enter the country code, area code (without the first zero) and phone number.
- 3 Press (M).

To answer a call

- Press (M).

To reject a call

- Press (M).

To change the ear speaker volume during a call

- Press the volume key up or down.

To mute the microphone during a call

- 1 Press and hold down (M) (M) appears.
- 2 Press and hold down (M) again to resume.

To turn on the loudspeaker during a call

- Select **Spkr on**. (M) appears.

⚡ Do not hold the phone to your ear when using the loudspeaker. This could damage your hearing.

Emergency calls

Your phone supports international emergency numbers, for example, 112 or 911. You can normally use these numbers to make emergency calls in any country, with or without the SIM card inserted, if you are within range of a network.

- In some countries, other emergency numbers may also be promoted. Your network operator may therefore have saved additional local emergency numbers on the SIM card.

To make an emergency call

- Enter 112 (the international emergency number) and press (M).

To view your local emergency numbers

- 1 Select **Menu** > **Contacts**.
- 2 Scroll to **New contact** and select **Options** > **Special numbers** > **Emergency numbers**.

Call list

You can view information about answered (M), dialled (M) and missed or rejected (M) calls.

To call a number from the call list

- 1 Press (M) and scroll to a tab.
- 2 Scroll to a name or a number and press (M).

Contacts

You can save names, phone numbers and personal information in **Contacts**. Information can be saved in the phone memory or on the SIM card.

- You can synchronise your contacts using the **Sony Ericsson PC Suite**.

To add a phone contact

- 1 Select **Menu** > **Contacts**.
- 2 Scroll to **New contact** and select **Add**.
- 3 Enter the name and select **OK**.
- 4 Scroll to **New number** and select **Add**.
- 5 Enter the number and select **OK**.
- 6 Select a number option.
- 7 Scroll between the tabs and add information to the fields.
- 8 Select **Save**.

Calling contacts

To call with Smart search

- 1 Press (M) – (M) to enter a sequence of (at least two) digits. All entries which match the sequence of digits or corresponding letters are shown in a list.
- 2 Scroll to a contact or a phone number and press (M).

To turn on or off Smart search

- 1 Select **Menu** > **Settings** > **Calls** > **Smart search**.
- 2 Select an option.

Imaging

You can take photos and record videos to view, save or send. You can find saved photos and videos in **Media** and in **File manager**.

Viewfinder and camera keys

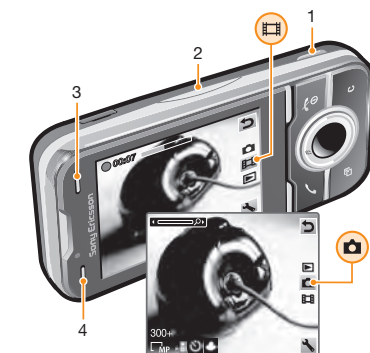

- 1 Activate the camera/Take photos/Record video

- 2 Zoom in or out
- 3 Still: **Flash Video: Light**
- 4 Still: **Scenes Video: Night mode**

To activate the camera

- From standby press and hold down (M).

Using the still camera

To take a photo

- 1 Activate the camera and press the navigation key to scroll to (M).
- 2 Press (M) halfway down to use auto focus. (M) fully down to take a photo. The photo is automatically saved.
- 3 When the dot and focus frame are green, press (M) fully down to take a photo. The photo is automatically saved.
- 4 To take another photo, press (M) to return to the viewfinder.

To use zoom

- Press the volume key.

To adjust brightness

- Press the navigation key. The amount of brightness is shown beside the (M).

Using the video camera

To record a video clip

- 1 Activate the camera and press the navigation key to scroll to (M).
- 2 Press (M) fully down to start recording.

- 3 To stop recording, press (M) fully down. The video clip is automatically saved.

Working with photos

You can view, enhance and organise photos and videos on your computer by installing the **Adobe™ Photoshop™ Album Starter Edition**. It is available for download at www.sonyericsson.com/support.

Use the **Media Go™** application to transfer content to and from your phone.

Using photos

You can add a photo to a contact, use the photo during phone startup, as a wallpaper in standby, or as a screen saver.

To use photos

- 1 Select **Menu** > **Media** > **Photo** > **Camera album**.
- 2 Select a month.
- 3 Scroll to a photo and select **View**.
- 4 Select **Options** > **Use as**.
- 5 Select an option.

Video player

To play videos

- 1 Select **Menu** > **Media** > **Video** > **Videos**.
- 2 Scroll to a title and select **Play**.

Music

You can listen to music, audio books and podcasts. Use the **Media Go™** application to transfer content to and from

your phone. For more information, see *Transferring content to and from a computer* on page 27.

Stereo portable handsfree



Music player

To play music

- 1 Select **Menu** > **Media** > **Music**.
- 2 Browse by category using the navigation key.
- 3 Scroll to a title and select **Play**.

To stop playing music

- Press the centre selection key.

To fast forward and rewind

- Press and hold down the navigation key right or left.

To move between tracks

- Press the navigation key right or left.

To change the volume

- Press the volume key up or down.

PlayNow™

When you select **PlayNow™** you enter PlayNow™ arena, where you can download music, games, ringtones, themes and wallpapers. You can preview or listen to content before you purchase and download it to your phone. If you cannot use PlayNow™ and PlayNow™ arena, see *I cannot use Internet-based services* on page 34.

- This service is not available in all countries.

For extended functionality, you can also access the PlayNow™ arena Web shop on a computer from www.playnow-arena.com. For more information, go to www.sonyericsson.com/support to read the PlayNow™ arena Feature guide.

To use PlayNow™

- 1 Select **Menu** > **PlayNow™**.
- 2 Scroll through PlayNow™ arena and follow the instructions to preview and purchase content.

spaces if no other items are added to the message. If you enter more than 160 characters, a second message is created. Your messages are sent as one concatenated message.

To create and send a message

- 1 Select **Menu** > **Messaging** > **Write new** > **Message**.
- 2 Enter text. To add items to the message, press the navigation key downwards, scroll by pressing the navigation key left or right, and select an item.
- 3 Select **Continue** > **Contacts look-up**.
- 4 Select a recipient and select **Send**.

- If you send a message to a group, you may be charged for each member. Contact your service provider for details.

Internet

If you cannot use the Internet, see *I cannot use Internet-based services* on page 34.

To start browsing

- 1 Select **Search**.
- 2 Enter a web address, a search phrase or the name of a bookmark.
- 3 Scroll to an item in the list and select **Go to** or **Search**.

To exit the browser

- 1 When you are browsing the web, select and then select .
- 2 Select **Exit browser**.

More features

Flight mode
In **Flight mode** the network and radio transceivers are turned off to prevent disturbance to sensitive equipment. When the flight mode menu is activated you are asked to select a mode the next time you turn on your phone:

- **Normal mode** – full functionality
- **Flight mode** – limited functionality

To activate the flight mode menu

- Select **Menu** > **Settings** > **General** > **Flight mode** > **Continue** > **Show at startup**.

To select flight mode

- 1 When the flight mode menu is activated, turn off your phone.
- 2 Turn on your phone and select **Flight mode**. appears.

Alarms

You can set a sound or the radio as an alarm signal. The alarm sounds even if the phone is turned off. When the alarm sounds you can silence it or turn it off.

To set the alarm

- 1 Select **Menu** > **Organiser** > **Alarms**.
- 2 Scroll to an alarm and select **Edit**.
- 3 Scroll to **Timer**, and select **Edit**.
- 4 Enter a time and select **OK** > **Save**.

To silence the alarm

- When the alarm sounds, press any key.

Error messages

Insert SIM

There is no SIM card in your phone or you may have inserted it incorrectly. See *To insert the SIM card* on page 3.

The SIM card connectors need cleaning. If the card is damaged, contact your network operator.

Insert correct SIM card

Your phone is set to work only with certain SIM cards. Check if you are using the correct operator SIM card.

Incorrect PIN/Incorrect PIN2

You have entered your PIN or PIN2 incorrectly. Enter the correct PIN or PIN2 and select **OK**.

PIN blocked/PIN2 blocked

You have entered your PIN or PIN2 code incorrectly three times in a row. To unblock, see *SIM protection* on page 32.

No netw. coverage

- Your phone is in flight mode. See *Flight mode* on page 30.
- Your phone is not receiving any network signal, or the received signal is too weak. Contact your network operator and make sure that the network has coverage where you are.
- The SIM card is not working properly. Insert your SIM card in another phone. If this works, it is probably your

TrackID™

TrackID™ is a music recognition service. You can search for title, artist and album name for a track you hear playing through a loudspeaker or on the radio in your phone. If you cannot use TrackID™, see *I cannot use Internet-based services* on page 34.

To search for track information

- When you hear a track through a loudspeaker, select **Menu** > **Entertainment** > **TrackID™** > **Start**.
- When the radio in your phone is playing select **Options** > **TrackID™**.

For best results, use TrackID™ in a quiet area.

Radio

- Do not use your phone as a radio in places where this is prohibited.

To turn on the radio

- 1 Connect a handsfree to the phone.
- 2 Select **Menu** > **Entertainment** > **Radio**.

Saving channels

You can save up to 20 preset channels.

To save channels automatically

- Select **Options** > **Channels** > **Auto save**.

To switch between saved channels

- Press the navigation key upwards or downwards.

You can also select a saved channel by pressing

- > .

Transferring and handling content

You can transfer and handle content such as pictures and music.

- You are not allowed to exchange some copyright-protected material. identifies a protected item.

Handling content in the phone

You can use **File manager** in your phone, to handle content saved in the phone memory or on a memory card. Tabs and icons in **File manager** show where the content is saved. If the memory is full, delete some content to create space.

To select more than one item in a folder

- 1 Select **Menu** > **Organiser** > **File manager**.
- 2 Scroll to a folder and select **Open**.
- 3 Select **Options** > **Mark** > **Mark several**.
- 4 For each item you want to mark, scroll to the item and select **Mark**.

To move items between the phone memory and the memory card

- 1 Select **Menu** > **Organiser** > **File manager**.
- 2 Find an item and select **Options** > **Manage file** > **Move**.

To select Memory card or Phone.

- 4 Scroll to a folder and select **Open**.
- 5 Select **Paste**.

To repeat the alarm, select **Snooze**.

To turn off the alarm

- When the alarm sounds, press any key, then select **Turn off**.

Calendar

You can synchronise your calendar with a computer calendar, with a calendar on the Web or with a Microsoft® Exchange Server (Microsoft® Outlook®).

Appointments

You can add new appointments or reuse existing appointments.

To add an appointment

- 1 Select **Menu** > **Organiser** > **Calendar**.
- 2 Select a date.
- 3 Scroll to **New entry** and select **Add**.
- 4 Enter the information and confirm each entry.
- 5 Select **Save**.

To set when reminders should sound

- 1 Select **Menu** > **Organiser** > **Calendar**.
- 2 Select a date.
- 3 Select **Options** > **Advanced** > **Reminders**.
- 4 Select an option.

A reminders option set in calendar affects a reminders option set in tasks.

To unlock the SIM card

- 1 When **PIN blocked** appears, enter your PUK and select **OK**.
- 2 Enter a new four-to-eight-digit PIN and select **OK**.
- 3 Re-enter the new PIN and select **OK**.

To edit the PIN

- 1 Select **Menu** > **Settings** > **General** > **PIN codes** > **SIM protection** > **Change PIN**.
- 2 Enter your PIN and select **OK**.
- 3 Enter a new four-to-eight-digit PIN and select **OK**.

Sending content to another phone

You can send content, for example, in messages or using Bluetooth wireless technology.

To send content

- 1 Scroll to an item and select **Options** > **Send**.
- 2 Select a transfer method.

Make sure the receiving device supports the transfer method you select.

Using a USB cable

You can connect your phone to a computer with a USB cable. If you are using a PC, you are asked to install PC Companion the first time you connect.

You may have to purchase a USB cable separately.

- Only use a USB cable supported by your phone.

PC Companion

PC Companion lets you:

- Explore content in your phone.
- Use your phone as a modem.
- Install PC Software used to synchronise, transfer and back up phone content.

For more information, go to www.sonyericsson.com/support to read Feature guides.

To download Mac compatible software, go to www.sonyericsson.com/support.

To install PC Companion

- 1 Connect your phone to a PC using a USB cable supported by your phone.

2 Computer: Follow the instructions.

To disconnect the USB cable safely

- Do not disconnect the USB cable when transferring content as this may corrupt the content.

- 1 Computer: Right-click the Safely Remove Hardware icon in Microsoft® Windows® Explorer.
- 2 Select the drives you want to disconnect. Select **Stop**.
- 3 Wait until you are notified that it is safe to remove the drive. Disconnect the USB cable.

Required operating systems

You need one of these operating systems to use Sony Ericsson PC software:

- Microsoft® Windows Vista™
- Microsoft® Windows® XP, Service Pack 2 or higher

Drag and drop content

You can drag and drop content between your phone, a memory card and a computer in Microsoft Windows Explorer.

To drag and drop content

- 1 Connect your phone to a computer using a USB cable.
- 2 Computer: Wait until the phone memory and memory card appear as external disks in Microsoft® Windows® Explorer.
- 3 Drag and drop selected files between the phone and the computer.

4 Re-enter the new PIN and select **OK**.

- If **Codes do not match** appears, you entered the new PIN incorrectly. If **Incorrect PIN** appears, you entered the old PIN incorrectly.

Troubleshooting

Some problems can be fixed using Update Service. Using Update Service on a regular basis will optimise the phone's performance. See *Updating your phone* on page 28. Some problems will require you to call your network operator.

For more support go to www.sonyericsson.com/support.

Common questions

I have problems with memory capacity or the phone is working slowly
Restart your phone every day to free memory or do a **Master reset**.

Master reset

If you select **Reset settings**, the changes that you have made to settings will be deleted.

If you select **Reset all**, your settings and content, such as contacts, messages, pictures, sounds and downloaded games, will be deleted. You may also lose content that was in the phone at purchase.

To reset the phone

- 1 Select **Menu** > **Settings** > **General** > **Master reset**.
- 2 Select an option.
- 3 Follow the instructions that appear.

Transferring content to and from a computer

You can use Media Go™ to transfer media content between your phone and a computer. Media Go™ is available for download through PC Companion or from www.sonyericsson.com/support.

To download Mac® compatible software, go to www.sonyericsson.com/support.

To transfer content using Media Go™

- 1 Connect the phone to a computer with a USB cable supported by your phone.
- 2 Computer: Select **Start/Programs/Sony/Media Go™**.
- 3 Select *Transfer to or from Device using Media Go™* and click **OK**.
- 4 Wait until the phone appears in Media Go™.
- 5 Move files between your phone and the computer in Media Go™.

Backing up and restoring

You can back up and restore contacts, the calendar, tasks, notes and bookmarks using the Sony Ericsson PC Suite. Before backing up and restoring, you need to install the Sony Ericsson PC Suite, which is available through PC Companion or from www.sonyericsson.com/support.

You can back up and restore contacts in your phone using a memory card. You can move content between the memory card and the phone memory. See *Handling content in the phone* on page 24.

Back up your phone content regularly to make sure you do not lose it.

To make a backup using the Sony Ericsson PC Suite

- 1 Computer: Start the Sony Ericsson PC Suite from *Start/Programs/Sony Ericsson/Sony Ericsson PC Suite*.
- 2 Follow the instructions in the Sony Ericsson PC Suite on how to connect.
- 3 Go to the backup and restore section in the Sony Ericsson PC Suite and make a backup of your phone content.

Updating your phone

You can update your phone to the most recent software for optimal performance and to get the latest enhancements. You need a USB cable and an Internet-connected PC.

To learn how, go to www.sonyericsson.com/update.

Remember to back up your phone content before updating. See *Backing up and restoring* on page 27.

Messaging

To view a message from the inbox

- 1 Select **Menu** > **Messaging** > **Messages** > **Inbox**.
- 2 Scroll to the message and select **View**.

To call a number in a message

- When you view the message, scroll to the phone number and press .

Sending messages
You can send messages from your phone. The maximum size of a standard text message is 160 characters including

To send most picture messages, you must set an MMS profile and the address of your message server. If no MMS profile or message server exists, you can receive all the settings automatically from your network operator, download settings using the Settings download or at www.sonyericsson.com/support.

To enter a service centre number

- 1 Select **Menu** > **Settings** > **Connectivity** > **Message settings** > **Text message** and scroll to the SIM card. The number is shown if it is saved on the SIM card.
- 2 If there is no number shown, select **Edit**.
- 3 Scroll to **New service centre** and select **Add**.
- 4 Enter the number, including the international "+" sign and country code.
- 5 Select **Save**.

To set the message server address

- 1 Select **Menu** > **Settings** > **Connectivity** > **Message settings** > **Multim. message**.
- 2 Select an existing profile or create a new one.

To select an MMS profile

- 1 Select **Menu** > **Settings** > **Connectivity** > **Message settings** > **Multim. message**.
- 2 Scroll to a profile and select **Options** > **Edit**.
- 3 Scroll to **Message server** and select **Edit**.
- 4 Enter the address and select **OK** > **Save**.

I cannot send messages from my phone
To send messages, you need to set a service centre number. The number is supplied by your service provider and is usually saved on the SIM card. If the number to your service centre is not saved on your SIM card, you must enter the number yourself.

The software or the USB drivers have not been properly installed. Go to www.sonyericsson.com/support to read

Feature guides which contain detailed installation instructions and troubleshooting sections.

Error messages

Insert SIM

There is no SIM card in your phone or you may have inserted it incorrectly. See *To insert the SIM card* on page 3.

The SIM card connectors need cleaning. If the card is damaged, contact your network operator.

Insert correct SIM card

Your phone is set to work only with certain SIM cards. Check if you are using the correct operator SIM card.

Incorrect PIN/Incorrect PIN2

You have entered your PIN or PIN2 incorrectly. Enter the correct PIN or PIN2 and select **OK**.

PIN blocked/PIN2 blocked

You have entered your PIN or PIN2 code incorrectly three times in a row. To unblock, see *SIM protection* on page 32.

No netw. coverage

- Your phone is in flight mode. See *Flight mode* on page 30.
- Your phone is not receiving any network signal, or the received signal is too weak. Contact your network operator and make sure that the network has coverage where you are.
- The SIM card is not working properly. Insert your SIM card in another phone. If this works, it is probably your

phone that is causing the problem. Please contact the nearest Sony Ericsson service location.

Emergency calls only

You are within range of a network, but you are not allowed to use it. However, in an emergency, some network operators allow you to call the international emergency number 112. See *Emergency calls* on page 16.

Legal information

Sony Ericsson Yari™ phone U100i/U100a
This User guide is published by Sony Ericsson Mobile Communications AB or its local affiliated company, without any warranty. Improvements and changes to this User guide necessitated by typographical errors, inaccuracies of current information, or improvements to programs and/or equipment, may be made by Sony Ericsson Mobile Communications AB at any time and without notice. Such changes will, however, be incorporated into new editions of this User guide.

All rights reserved.
©Sony Ericsson Mobile Communications AB, 2009
Publication number: xxx-xxxx.1

Your mobile phone has the capability to download, store and forward additional content, e.g. ringtones. The use of such content may be restricted or prohibited by rights of third parties, including but not limited to restriction under applicable copyright laws. You, and not Sony Ericsson, are entirely responsible for additional content that you download to or forward from your mobile phone. Prior to your use of any additional content, please verify that your intended use is properly licensed or is otherwise authorized. Sony Ericsson does not guarantee the accuracy, integrity or quality of any additional content or any other third party content. Under no circumstances will Sony Ericsson be liable in any way for your improper use of additional content or other third party content.

Bluetooth is a trademark or a registered trademark of Bluetooth SIG Inc. and any use of such mark by Sony Ericsson is under license.

The Liquid Identity logo, PlayNow and Yari™ phone are trademarks or registered trademarks of Sony Ericsson Mobile Communications AB. Sony is a trademark or registered trademark of Sony Corporation.

Media Go is a trademark or registered trademark of Sony Media Software and Services.

microSD is a trademark or a registered trademark of SanDisk Corporation.

Ericsson is a trademark or registered trademark of Telefonaktiebolaget LM Ericsson.

Adobe Photoshop Album Starter Edition is a trademark or registered trademark of Adobe Systems Incorporated in the United States and/or other countries.

Mac is a trademark of Apple Inc., registered in the U.S. and other countries.

Microsoft, Windows, Outlook, Windows Vista, Windows Server and ActiveSync are registered trademarks or trademarks of Microsoft Corporation in the United States and/or other countries.

This product is protected by certain intellectual property rights of Microsoft. Use or distribution of such technology outside of this product is prohibited without a license from Microsoft.

Other product and company names mentioned herein may be the trademarks of their respective owners.

Any rights not expressly granted herein are reserved. All illustrations are for illustration only and may not accurately depict the actual phone.

www.sonyericsson.com

Sony Ericsson

Sony Ericsson Mobile Communications AB
SE-221 88 Lund, Sweden

xxxx-xxxx.1

36

37

38

39

40

41

42



Sony Ericsson Mobile Communications AB
SE-221 88 Lund, Sweden



1226-7525.2

Sony Ericsson U100i

UMTS HSPA Band 1 8 GSM GPRS/EDGE 850/900/1800/1900

Important Information

United States & Canada

THIS PHONE MODEL HAS BEEN CERTIFIED IN COMPLIANCE WITH THE GOVERNMENT'S REQUIREMENTS FOR EXPOSURE TO RADIO WAVES.

The Series mobile phones have been designed to comply with applicable safety requirements for exposure to radio waves. Your wireless phone is a radio transmitter and receiver. It is designed to not exceed the limits* of exposure to radio frequency (RF) energy set by governmental authorities. These limits establish permitted levels of RF energy for the general population. The guidelines are based on standards that were developed by international scientific organizations through periodic and thorough evaluation of scientific studies. The standards include a safety margin designed to assure the safety of all individuals, regardless of age and health.

The radio wave exposure guidelines employ a unit of measurement known as the Specific Absorption Rate (SAR). Tests for SAR are conducted using standardized methods with the phone transmitting at its highest certified power level in all used frequency bands. While there may be differences between the SAR levels of various phone models, they are all designed to meet the relevant guidelines for exposure to radio waves. For more information on SAR, please refer to the safe and efficient use chapter in the User Guide.

The highest SAR value as reported to the authorities for this phone model when tested for use by the ear is 0.71 W/kg*, and when worn on the body is 0.34 W/kg* for speech and 0.41 W/kg* for data calls. Body worn measurements are made while the phone is in use and worn on the body with a Sony Ericsson accessory supplied with or designated for use with this phone. It is therefore recommended that only Ericsson and Sony Ericsson original accessories be used in conjunction with Sony Ericsson phones.

**Before a phone model is available for sale to the public in the US, it must be tested and certified by the Federal Communications Commission (FCC) that it does not exceed the limit established by

2

the government-adopted requirement for safe exposure*. The tests are performed in positions and locations (i.e., by the ear and worn on the body) as required by the FCC for each model. The FCC has granted an Equipment Authorization for this phone model with all reported SAR levels evaluated as in compliance with the FCC RF exposure guidelines. While there may be differences between the SAR levels of various phones, all mobile phones granted an FCC equipment authorization meet the government requirement for safe exposure. SAR information on this phone model is on file at the FCC and can be found under the Display Grant section of <http://www.fcc.gov/oet/fccid> after searching on FCC ID PY7A3880046. Additional information on SAR can be found on the Cellular Telecommunications & Internet Association (CTIA) website at <http://www.phonefacts.net>.

* In the United States and Canada, the SAR limit for mobile phones used by the public is 1.6 watts/kilogram (W/kg) averaged over one gram of tissue. The standard incorporates a margin of safety to give additional protection for the public and to account for any variations in measurements.

**This paragraph is only applicable to authorities and customers in the United States.

3

Renseignements importants

États-Unis et Canada

CE MODÈLE DE TÉLÉPHONE A ÉTÉ CERTIFIÉ CONFORME AUX EXIGENCES GOUVERNEMENTALES RELATIVES À L'EXPOSITION AUX ONDES RADIOÉLECTRIQUES.

Les téléphones mobiles ont été conçus pour répondre aux normes de sécurité en vigueur en matière d'exposition aux ondes radioélectriques. Votre téléphone sans fil est un émetteur et un récepteur radio. Il est conçu de manière à ne pas dépasser les limites* d'exposition aux signaux radiofréquences (RF) établies par les autorités gouvernementales. Ces limites fixent les niveaux maximaux d'énergie radiofréquence auxquels peut être soumis le grand public. Ces lignes directrices sont basées sur des normes qui ont été élaborées par des organisations scientifiques internationales par le biais d'évaluations périodiques et approfondies des études scientifiques. Ces normes prévoient une marge de sécurité visant à assurer la protection de toutes les personnes, quels que soient leur âge et leur état de santé.

Les lignes directrices relatives à l'exposition aux ondes radioélectriques utilisent une unité de mesure appelée "Débit d'absorption spécifique" (SAR). Les tests de SAR sont effectués selon des méthodes standardisées dans lesquelles le téléphone émet dans toutes les bandes de fréquences utilisées, à la plus forte puissance pour laquelle il a été homologué. Bien que le débit d'absorption spécifique puisse être différent d'un modèle de téléphone à un autre, tous les appareils sont conçus pour respecter les lignes directrices relatives aux ondes radioélectriques. Pour en savoir plus sur le débit d'absorption spécifique, reportez-vous au chapitre sur l'utilisation efficace et sans danger de ce présent guide.

Le débit d'absorption spécifique le plus élevé relevé par les autorités pour ce modèle de téléphone est de 0,71 W/kg* lorsqu'il est testé en utilisation près de l'oreille, et de 0,34 W/kg* (pour les appels vocaux) et de 0,41 W/kg* (pour les appels de données) lorsqu'il est porté sur le corps. Lors des mesures de port sur le corps, le téléphone était maintenu par un accessoire Sony

4

Ericsson fourni avec ce téléphone ou conçu pour être utilisé avec l'appareil. Il est par conséquent recommandé de n'utiliser que les accessoires authentiques Ericsson et Sony Ericsson avec les téléphones Sony Ericsson.

**Avant qu'un modèle de téléphone ne soit offert au public aux États-Unis, la FCC (Federal Communications Commission) doit le tester et certifier qu'il respecte les limites fixées dans les exigences gouvernementales d'exposition sans danger*. Pour chaque modèle, les tests sont effectués en position et aux endroits d'usage (c'est-à-dire près de l'oreille et porté sur le corps), tel que l'exige la FCC. La FCC a accordé une autorisation d'équipement (Equipment Authorization) pour ce modèle de téléphone, après que tous les débits d'absorption spécifique indiqués aient été évalués et considérés conformes aux lignes directrices de la FCC en matière d'exposition aux radiofréquences. Même s'il peut y avoir des différences entre les niveaux de SAR des différents téléphones, tous les téléphones mobiles auxquels la FCC a accordé une autorisation d'équipement répondent aux normes gouvernementales en matière d'exposition sans danger. La FCC conserve dans ses dossiers l'information relative aux débits d'absorption spécifique relevés pour ce modèle de téléphone. Vous pouvez la consulter au <http://www.fcc.gov/oet/fccid>, sous la rubrique "Display Grant". Vous trouverez des renseignements supplémentaires concernant le débit d'absorption spécifique (SAR) sur le site Web de la Cellular Telecommunications & Internet Association (CTIA) au <http://www.phonefacts.net>.

*Aux États-Unis et au Canada, la limite de débit d'absorption spécifique (SAR) des téléphones mobiles utilisés par le public est de 1,6 watt/kg (W/kg) en moyenne sur un gramme de tissu. Cette norme comporte une marge importante de sécurité afin d'assurer une protection supplémentaire et de tenir compte de toute variation dans les mesures.

**Ce paragraphe ne concerne que les autorités et les clients des États-Unis.

5

Información importante

Estados Unidos y Canadá

ESTE MODELO DE TELÉFONO HA SIDO CERTIFICADO Y CUMPLE CON LOS REQUISITOS GUBERNAMENTALES DE EXPOSICIÓN A LAS ONDAS DE RADIO.

El teléfono móvil ha sido diseñado para cumplir con los requisitos de seguridad aplicables de exposición a las ondas de radio. El teléfono inalámbrico es un transmisor y receptor de radio. Está diseñado para no superar los límites* de exposición a la energía de radiofrecuencia (RF) establecidos por las autoridades gubernamentales. Estos límites establecen los niveles permitidos de energía de RF para la población en general. Las especificaciones se basan en los estándares desarrollados por organizaciones científicas internacionales mediante una evaluación periódica y minuciosa de estudios científicos. Estos estándares incluyen un margen de seguridad destinado a garantizar la seguridad de todas las personas, independientemente de su edad y condición de salud.

Las especificaciones de exposición a las ondas de radio emplean una unidad de medición conocida como Tasa específica de absorción (SAR). Las pruebas de SAR se realizan usando métodos estandarizados mientras el teléfono transmite al nivel de potencia más alto certificado en todas las bandas de frecuencia utilizadas. Si bien puede haber diferencias entre los niveles de SAR de diversos modelos de teléfono, todos los teléfonos han sido diseñados para cumplir con las especificaciones pertinentes de exposición a las ondas de radio. Para obtener más información acerca de SAR, consulte el capítulo sobre uso seguro y eficaz en la Guía del usuario.

El mayor valor SAR según lo informado a las autoridades para este teléfono cuando se evaluó para su uso cerca del oído fue de 0,71 W/kg*, y cuando se utilizó cerca del cuerpo fue de 0,34 W/kg* para llamadas de voz y 0,41 W/kg* para llamadas de datos. Las mediciones para el uso cerca del cuerpo se realizan mientras el teléfono está en uso y ubicado cerca del cuerpo con un accesorio Sony Ericsson proporcionado con el teléfono o diseñado para su

6

uso con este teléfono. Por lo tanto, se recomienda utilizar sólo accesorios originales Ericsson y Sony Ericsson en conjunto con los teléfonos Sony Ericsson.

**Antes de que un modelo de teléfono esté disponible para la venta al público en los EE.UU., se debe probar y certificar ante la Comisión Federal de Comunicaciones (FCC) que no supera el límite establecido por los requisitos gubernamentales de exposición segura*. Las pruebas se realizan en las posiciones y lugares (es decir, en el oído y cerca del cuerpo) exigidos por la FCC para cada modelo. La FCC ha otorgado una Autorización de equipo para este modelo de teléfono con todos los niveles SAR informados y que han sido evaluados en cumplimiento con las especificaciones de exposición de RF de la FCC. Si bien puede haber diferencias en los niveles SAR entre distintos modelos de teléfonos móviles, todos los teléfonos móviles que han recibido una autorización de equipo de la FCC cumplen con los requisitos gubernamentales de exposición segura. La información de SAR acerca de este modelo de teléfono está archivada en la FCC y se puede encontrar en la sección Display Grant de <http://www.fcc.gov/oet/fccid> luego de buscar en FCC ID PY7A3880046. Si desea información adicional acerca de SAR, puede encontrarla en el sitio Web de la Asociación de Telecomunicaciones Celulares e Internet (CTIA, Cellular Telecommunications & Internet Association) en la dirección <http://www.phonefacts.net>.

* En los Estados Unidos y Canadá, el límite SAR para teléfonos móviles utilizados por el público es de 1,6 watts/kilogramo (W/kg) promediado sobre un gramo de tejido. El estándar incorpora un margen de seguridad para entregar protección adicional al público y para representar las variaciones en las mediciones.

**Este párrafo sólo es aplicable a las autoridades y clientes en los Estados Unidos.

7

Important Information

Latin & South America

Radio wave exposure and Specific Absorption Rate (SAR) information

The Series mobile phones have been designed to comply with applicable safety requirements for exposure to radio waves. These requirements are based on scientific guidelines that include safety margins designed to assure the safety of all persons, regardless of age and health.

The radio wave exposure guidelines employ a unit of measurement known as the Specific Absorption Rate, or SAR. Tests for SAR are conducted using standardised methods with the phone transmitting at its highest certified power level in all used frequency bands.

While there may be differences between the SAR levels of various phone models, they are all designed to meet the relevant guidelines for exposure to radio waves.

For more information on SAR, please refer to the safety chapter in the User Guide.

SAR data information for residents in countries that have adopted the SAR limit recommended by the International Commission on Non-Ionizing Radiation Protection (ICNIRP), which is 2 W/kg averaged over ten (10) gram of tissue (for example European Union, Japan, Brazil and New Zealand):

The highest SAR value for this model phone when tested by Sony Ericsson for use at the ear is 0.69 W/kg (10g).

8

Información importante

Latinoamérica y América del Sur

Información acerca de la exposición a ondas de radio y la Tasa específica de absorción (SAR)

El teléfono móvil ha sido diseñado para cumplir con los requisitos de seguridad aplicables de exposición a las ondas de radio. Dichos requisitos se basan en directrices científicas que establecen márgenes de seguridad con el fin de evitar perjuicios a todas las personas, independientemente de su edad o estado de salud.

Las directrices de exposición a ondas de radio utilizan una unidad de medida denominada coeficiente de absorción específica o SAR. Las pruebas de SAR se llevan a cabo utilizando métodos normalizados, con el teléfono transmitiendo en el nivel más elevado de potencia autorizado en todas las bandas de frecuencia utilizadas.

Aunque puede existir diferencias entre los niveles de SAR de diferentes modelos de teléfono, todos han sido diseñados para cumplir las directrices pertinentes sobre exposición a ondas de radio.

Para obtener más información sobre el SAR, consulte el capítulo sobre seguridad en la guía del usuario.

Información sobre datos de SAR para residentes de países en los que se haya adoptado el límite de SAR recomendado por la International Commission on Non-Ionizing Radiation Protection (ICNIRP, Comisión internacional de protección contra la radiación no ionizantes (ICNIRP, International Commission on Non-Ionizing Radiation Protection), es 2 W/kg promedio por cada diez (10) gramos de tejido (por ejemplo, la Unión Europea, Japón, Brasil y Nueva Zelanda):

El valor de SAR más elevado para este modelo de teléfono cuando Sony Ericsson realizó la prueba para su uso en la oreja era de 0,69 W/kg (10g).

9

Informação importante

América do Sul e Latina

Informações sobre SAR (Taxa de Absorção Específica) e exposição à radiofrequência

O celular foi projetado para cumprir os requisitos de segurança aplicáveis para exposição à radiofrequência. Esses requisitos têm como base diretrizes científicas que incluem as margens de segurança para garantir a segurança de todas as pessoas, independentemente da idade e da saúde.

As diretrizes de exposição à radiofrequência usam uma unidade de medida conhecida como SAR ou Taxa de Absorção Específica. Os testes de SAR são conduzidos por métodos padronizados com a transmissão telefônica em seu nível certificado de energia mais alto em todas as faixas de frequência usadas.

Embora possa haver diferenças entre os níveis de SAR de vários modelos de telefone, todos foram projetados para atender as diretrizes relevantes de exposição à radiofrequência.

Para obter mais informações sobre SAR, consulte o capítulo de segurança do Guia do Usuário.

Informações sobre os dados de SAR para moradores de países que adotaram o limite SAR recomendado pelo ICNIRP (International Commission on Non-Ionizing Radiation Protection) que é o limite médio de 2 W/kg em dez (10) gramas de tecido (por exemplo, União Européia, Japão, Brasil e Nova Zelândia).

Quando testado pela Sony Ericsson, o valor de SAR mais alto para este modelo de telefone para uso junto ao ouvido foi de 0,69 W/kg (10g).

10

FCC Statement

This device complies with Part 15 of the FCC rules.

Operation is subject to the following two conditions: (1)

This device may not cause harmful interference, and (2)

This device must accept any interference received, including interference that may cause undesired operation.

Any change or modification not expressly approved by Sony Ericsson may void the user's authority to operate the equipment.

This equipment has been tested and found to comply with the limits for a Class B digital device, pursuant to Part 15 of the FCC Rules. These limits are designed to provide reasonable protection against harmful interference in a residential installation. This equipment generates, uses and can radiate radio frequency energy and, if not installed and used in accordance with the instructions, may cause harmful interference to radio communications. However, there is no guarantee that interference will not occur in a particular installation.

If this equipment does cause harmful interference to radio or television reception, which can be determined by turning the equipment off and on, the user is encouraged to try to correct the interference by one or more of the following measures:

- Reorient or relocate the receiving antenna.
- Increase the separation between the equipment and receiver.
- Connect the equipment into an outlet on a circuit different from that to which the receiver is connected.
- Consult the dealer or an experienced radio/TV technician for help.



11

Industry Canada Statement

This device complies with RSS-210 of Industry Canada.

Operation is subject to the following two conditions: (1) this device may not cause interference, and (2) this device must accept any interference, including interference that may cause undesired operation of the device.

This Class B digital apparatus complies with Canadian ICES-003.

Cet appareil numérique de la classe B est conforme à la norme NMB-003 du Canada.

12

Declaration of Conformity for U100i

We, **Sony Ericsson Mobile Communications AB** of

Nya Vattentorget

SE-221 88 Lund, Sweden

declare under our sole responsibility that our product

Sony Ericsson type AAD-3880046-BV

and in combination with our accessories, to which this declaration relates is in conformity with the appropriate standards EN 301 511:V9.0.2, EN 301 908-1:V3.2.1, EN 301 908-2:V3.2.1, EN 300 328:V1.7.1, EN 301 489-7:V1.3.1, EN 301 489-17:V2.1.1, EN 301 489-24:V1.4.1 and EN 60 950-1:2006 following the provisions of, Radio Equipment and Telecommunication Terminal Equipment directive **1999/5/EC**.

Lund, August 2009

CE 0682

Rikko Sakaguchi,

Corporate Vice President and Head of Creation & Development

We fulfil the requirements of the R&TTE Directive (1999/5/EC).

Ce produit est conforme aux directives de R&TTE (1999/5/EC).

Cumplimos con los requisitos de la Directiva R&TTE – Normas sobre equipos de terminales de radio y telecomunicaciones (1999/5/EC).

Atendemos aos requisitos da Diretriz R&TTE (1999/5/EC).

13

Sony Ericsson

Important information

Sony Ericsson Consumer Web site

At www.sonyericsson.com/support there is a support section where help and tips are only a few clicks away. Here you will find the latest computer software updates and tips on how to use your product more efficiently.

Service and support

You have access to a portfolio of exclusive service advantages such as:

- Global and local Web sites providing support.
- A global network of call centres.
- An extensive network of Sony Ericsson service partners.
- A warranty period. Learn more about the warranty conditions in the Important information.

At www.sonyericsson.com/support, you can find the latest support tools and information. For operator-specific services and features, please contact your network operator.

You can also contact our call centres. If your country/region is not represented in the list below, please contact your local dealer. (Calls are charged according to national rates, including local taxes, unless the phone number is a toll-free number.)

If your product needs service, please contact the dealer from whom it was purchased, or one of our service partners. For warranty claims, save proof of purchase.

Guidelines for Safe and Efficient Use

Please follow these guidelines. Failure to do so might entail a potential health risk or product malfunction. If in doubt as to its proper function, have the product checked by a certified service partner before charging or using it.



Recommendations for care and safe use of our products

- Handle with care and keep in a clean and dust-free place.
- **Warning!** May explode if disposed of in fire.

- Do not expose to liquid or moisture or excess humidity.
- For optimum performance, the product should not be operated in temperatures below $-10^{\circ}\text{C}(+14^{\circ}\text{F})$ or above $+45^{\circ}\text{C}(+113^{\circ}\text{F})$. Do not expose the battery to temperatures above $+60^{\circ}\text{C}(+140^{\circ}\text{F})$.



- Do not expose to flames or lit tobacco products.
- Do not drop, throw or try to bend the product.
- Do not paint or attempt to disassemble or modify the product. Only Sony Ericsson authorised personnel should perform service.
- Consult with authorised medical staff and the instructions of the medical device manufacturer before using the product near pacemakers or other medical devices or equipment.



- Discontinue use of electronic devices, or disable the radio transmitting functionality of the device, where required or requested to do so.
- Do not use where a potentially explosive atmosphere exists.
- Do not place the product, or install wireless equipment, in the area above an air bag in a car.
- **Caution:** Cracked or broken displays may create sharp edges or splinters that could be harmful upon contact.
- Do not use the Bluetooth Headset in positions where it is uncomfortable or will be subject to pressure.

Children

Warning! Keep out of the reach of children. Do not allow children to play with mobile phones or accessories. They could hurt themselves or others. Products may contain small parts that could become detached and create a choking hazard.



Power supply (Charger)

Connect the charger to power sources as marked on the product. Do not use outdoors or in damp areas. Do not alter or subject the cord to damage or stress. Unplug the unit before cleaning it. Never alter the plug. If it does not fit into the outlet, have a proper

outlet installed by an electrician. When a power supply is connected there is a small drain of power. To avoid this small energy waste, disconnect the power supply when the product is fully charged. Use of charging devices that are not Sony Ericsson branded may pose increased safety risks.

Battery

New or idle batteries can have short-term reduced capacity. Fully charge the battery before initial use. Use for the intended purpose only. Charge the battery in temperatures between +5°C(+41°F) and +45°C(+113°F). Do not put the battery into your mouth. Do not let the battery contacts touch another metal object. Turn off the product before removing the battery. Performance depends on temperatures, signal strength, usage patterns, features selected and voice or data transmissions. Only Sony Ericsson service partners should remove or replace built-in batteries. Use of batteries that are not Sony Ericsson branded may pose increased safety risks. Replace the battery only with another Sony Ericsson battery that has been qualified with the product per the standard IEEE-1725. Use of an unqualified battery may present a risk of fire, explosion, leakage or other hazard.

Personal medical devices

Mobile phones may affect implanted medical equipment. Reduce risk of interference by keeping a minimum distance of 15 cm(6 inches) between the phone and the device. Use the phone at your right ear. Do not carry the phone in your breast pocket. Turn off the phone if you suspect interference. For all medical devices, consult a physician and the manufacturer.

Driving

Some vehicle manufacturers forbid the use of phones in their vehicles unless a handsfree kit with an external antenna supports the installation. Check with the vehicle manufacturer's representative to be sure that the mobile phone or Bluetooth handsfree will not affect the electronic systems in the vehicle. Full attention should be given to driving at all times and local laws and

regulations restricting the use of wireless devices while driving must be observed.

GPS/Location based functions

Some products provide GPS/Location based functions. Location determining functionality is provided "As is" and "With all faults". Sony Ericsson does not make any representation or warranty as to the accuracy of such location information.

Use of location-based information by the device may not be uninterrupted or error free and may additionally be dependent on network service availability. Please note that functionality may be reduced or prevented in certain environments such as building interiors or areas adjacent to buildings.

Caution: Do not use GPS functionality in a manner which causes distraction from driving.

Emergency calls

Calls cannot be guaranteed under all conditions. Never rely solely upon mobile phones for essential communication. Calls may not be possible in all areas, on all networks, or when certain network services and/or phone features are used.

Antenna

Use of antenna devices not marketed by Sony Ericsson could damage the phone, reduce performance, and produce SAR levels above the established limits. Do not cover the antenna with your hand as this affects call quality, power levels and can shorten talk and standby times.

Radio Frequency (RF) exposure and Specific Absorption Rate (SAR)

When the phone or Bluetooth handsfree is turned on, it emits low levels of radio frequency energy. International safety guidelines have been developed through periodic and thorough evaluation of scientific studies. These guidelines establish permitted levels of radio wave exposure. The guidelines include a safety margin

designed to assure the safety of all persons and to account for any variations in measurements.

Specific Absorption Rate (SAR) is used to measure radio frequency energy absorbed by the body when using a mobile phone. The SAR value is determined at the highest certified power level in laboratory conditions, but because the phone is designed to use the minimum power necessary to access the chosen network, the actual SAR level can be well below this value. There is no proof of difference in safety based on difference in SAR value.

Products with radio transmitters sold in the US must be certified by the Federal Communications Commission (FCC). When required, tests are performed when the phone is placed at the ear and when worn on the body. For body-worn operation, the phone has been tested when positioned a minimum of 15 mm from the body without any metal parts in the vicinity of the phone or when properly used with an appropriate Sony Ericsson accessory and worn on the body.

For more information about SAR and radio frequency exposure, go to: www.sonyericsson.com/health.

Flight mode

Bluetooth and WLAN functionality, if available in the device, can be enabled in Flight mode but may be prohibited onboard aircraft or in other areas where radio transmissions are prohibited. In such environments, please seek proper authorisation before enabling Bluetooth or WLAN functionality even in Flight mode.

Malware

Malware (short for malicious software) is software that can harm the mobile phone or other computers. Malware or harmful applications can include viruses, worms, spyware, and other unwanted programs. While the device does employ security measures to resist such efforts, Sony Ericsson does not warrant or represent that the device will be impervious to the introduction of malware. You can however reduce the risk of malware attacks by using care when downloading content or accepting

applications, refraining from opening or responding to messages from unknown sources, using trustworthy services to access the Internet, and only downloading content to the mobile phone from known, reliable sources.

Accessories

Use only Sony Ericsson branded original accessories and certified service partners. Sony Ericsson does not test third-party accessories. Accessories may influence RF exposure, radio performance, loudness, electric safety and other areas. Third-party accessories and parts may pose a risk to your health or safety or decrease performance.

Accessible Solutions/Special Needs

In the US, compatible Sony Ericsson phones may offer compatibility with TTY terminals (with use of necessary accessory). For more information call the Sony Ericsson Special Needs Center on 877 878 1996 (TTY) or 877 207 2056 (voice), or go to www.sonyericsson-snc.com.

Disposal of old electrical and electronic equipment

Electronic equipment and batteries should not be included as household waste but should be left at an appropriate collection point for recycling. This helps prevent potential negative consequences for the environment and human health. Check local regulations by contacting your local city office, your household waste disposal service, the shop where you purchased the product or calling a Sony Ericsson call centre. Do not attempt to remove internal batteries. Internal batteries shall be removed only by a waste treatment facility or trained service professional.



Disposing of the battery

Check local regulations or call a Sony Ericsson call centre for information. Never use municipal waste.



Memory card

If the product comes complete with a removable memory card, it is generally compatible with the handset purchased but may not be compatible with other devices or the capabilities of their memory cards. Check other devices for compatibility before purchase or use. If the product is equipped with a memory card reader, check memory card compatibility before purchase or use.

Memory cards are generally formatted prior to shipping. To reformat the memory card, use a compatible device. Do not use the standard operating system format when formatting the memory card on a PC. For details, refer to the operating instructions of the device or contact customer support.

Warning!

If the device requires an adapter for insertion into the handset or another device, do not insert the card directly without the required adapter.

Precautions on memory card use

- Do not expose the memory card to moisture.
- Do not touch terminal connections with your hand or any metal object.
- Do not strike, bend, or drop the memory card.
- Do not attempt to disassemble or modify the memory card.
- Do not use or store the memory card in humid or corrosive locations or in excessive heat such as a closed car in summer, in direct sunlight or near a heater, etc.
- Do not press or bend the end of the memory card adapter with excessive force.
- Do not let dirt, dust, or foreign objects get into the insert port of any memory card adapter.
- Check you have inserted the memory card correctly.
- Insert the memory card as far as it will go into any memory card adapter needed. The memory card may not operate properly unless fully inserted.

- We recommend that you make a backup copy of important data. We are not responsible for any loss or damage to content you store on the memory card.
- Recorded data may be damaged or lost when you remove the memory card or memory card adapter, turn off the power while formatting, reading or writing data, or use the memory card in locations subject to static electricity or high electrical field emissions.

Protection of personal information

Erase personal data before disposing of the product. To delete data, perform a master reset. Deleting data from the phone memory does not ensure that it cannot be recovered. Sony Ericsson does not warrant against recovery of information and does not assume responsibility for disclosure of any information even after a master reset.

Loudness warning!

Avoid volume levels that may be harmful to your hearing.

End User Licence Agreement

Software delivered with this device and its media is owned by Sony Ericsson Mobile Communications AB, and/or its affiliated companies and its suppliers and licensors.

Sony Ericsson grants you a non-exclusive limited licence to use the Software solely in conjunction with the Device on which it is installed or delivered. Ownership of the Software is not sold, transferred or otherwise conveyed.

Do not use any means to discover the source code or any component of the Software, reproduce and distribute the Software, or modify the Software. You are entitled to transfer rights and obligations to the Software to a third party, solely together with the Device with which you received the Software, provided the third party agrees in writing to be bound by the terms of this Licence.

This licence exists throughout the useful life of this Device. It can be terminated by transferring your rights to the Device to a third party in writing.

Failure to comply with any of these terms and conditions will terminate the licence immediately.

Sony Ericsson and its third party suppliers and licensors retain all rights, title and interest in and to the Software. To the extent that the Software contains material or code of a third party, such third parties shall be beneficiaries of these terms.

This licence is governed by the laws of Sweden. When applicable, the foregoing applies to statutory consumer rights.

In the event Software accompanying or provided in conjunction with your device is provided with additional terms and conditions, such provisions shall also govern your possession and usage of the Software.

Limited Warranty

Sony Ericsson Mobile Communications AB, SE-221 88 Lund, Sweden, (Sony Ericsson) or its local affiliated company, provides this Limited Warranty for your mobile phone, original accessory delivered with your mobile phone, and/or your mobile computing product (hereinafter referred to as "Product").

Should your Product need warranty service, please return it to the dealer from whom it was purchased, or contact your local Sony Ericsson Call Center (national rates may apply) or visit www.sonyericsson.com to get further information.

Our warranty

Subject to the conditions of this Limited Warranty, Sony Ericsson warrants this Product to be free from defects in design, material and workmanship at the time of its original purchase by a consumer. This Limited Warranty will last for a period of two (2) years as from the original date of purchase of the Product for your mobile phone, and for a period of one (1) year following the original purchase date of the Product for all original accessories

(such as the battery, charger or handsfree kit) which may be delivered with your mobile phone.

What we will do

If, during the warranty period, this Product fails to operate under normal use and service, due to defects in design, materials or workmanship, Sony Ericsson authorised distributors or service partners, in the country/region* where you purchased the Product, will, at their option, either repair or replace the Product in accordance with the terms and conditions stipulated herein.

Sony Ericsson and its service partners reserve the right to charge a handling fee if a returned Product is found not to be under warranty according to the conditions below.

Please note that some of your personal settings, downloads and other information may be lost when your Sony Ericsson Product is repaired or replaced. At present, Sony Ericsson may be prevented by applicable law, other regulation or technical restrictions from making a backup copy of certain downloads. Sony Ericsson does not take any responsibility for any lost information of any kind and will not reimburse you for any such loss. You should always make backup copies of all the information stored on your Sony Ericsson Product such as downloads, calendar and contacts before handing in your Sony Ericsson Product for repair or replacement.

Conditions

1. This Limited Warranty is valid only if the original proof of purchase for this Product issued by a Sony Ericsson authorised dealer specifying the date of purchase and serial number**, is presented with the Product to be repaired or replaced. Sony Ericsson reserves the right to refuse warranty service if this information has been removed or changed after the original purchase of the Product from the dealer.
2. If Sony Ericsson repairs or replaces the Product, the repair for the defect concerned, or the replaced Product shall be warranted for the remaining time of the original warranty period or for ninety (90) days from the date of repair, whichever is

longer. Repair or replacement may involve the use of functionally equivalent reconditioned units. Replaced parts or components will become the property of Sony Ericsson.

3. This warranty does not cover any failure of the Product due to normal wear and tear, or due to misuse, including but not limited to use in other than the normal and customary manner, in accordance with the Sony Ericsson instructions for use and maintenance of the Product. Nor does this warranty cover any failure of the Product due to accident, software or hardware modification or adjustment, acts of God or damage resulting from liquid.

A rechargeable battery can be charged and discharged more than a hundred times. However, it will eventually wear out – this is not a defect and corresponds to normal wear and tear. When the talk-time or standby time is noticeably shorter, it is time to replace the battery. Sony Ericsson recommends that you use only batteries and chargers approved by Sony Ericsson.

Minor variations in display brightness and colour may occur between phones. There may be tiny bright or dark dots on the display. These are called defective pixels and occur when individual dots have malfunctioned and can not be adjusted. Two defective pixels are deemed acceptable.

Minor variations in camera image appearance may occur between phones. This is nothing uncommon and is not regarded as a defective camera module.

4. Since the cellular system on which the Product is to operate is provided by a carrier independent from Sony Ericsson, Sony Ericsson will not be responsible for the operation, availability, coverage, services or range of that system.
5. This warranty does not cover Product failures caused by installations, modifications, or repair or opening of the Product performed by a non-Sony Ericsson authorised person.
6. The warranty does not cover Product failures which have been caused by use of accessories or other peripheral devices which are not Sony Ericsson branded original accessories intended for use with the Product.

Sony Ericsson disclaims any and all warranties, whether express or implied, for failures caused to the Product or peripheral devices as a result of viruses, trojan horses, spyware, or other malicious software. Sony Ericsson strongly recommends that you install appropriate virus protection software on your Product and any peripheral devices connected to it, as available, and update it regularly, to better protect your device. It is understood, however, that such software will never fully protect your Product or its peripheral devices and Sony Ericsson disclaims all warranties, whether express or implied, in case of failure by such antivirus software to fulfil its intended purpose.

7. Tampering with any of the seals on the Product will void the warranty.
8. THERE ARE NO EXPRESS WARRANTIES, WHETHER WRITTEN OR ORAL, OTHER THAN THIS PRINTED LIMITED WARRANTY. ALL IMPLIED WARRANTIES, INCLUDING WITHOUT LIMITATION THE IMPLIED WARRANTIES OF MERCHANTABILITY OR FITNESS FOR A PARTICULAR PURPOSE, ARE LIMITED TO THE DURATION OF THIS LIMITED WARRANTY. IN NO EVENT SHALL SONY ERICSSON OR ITS LICENSORS BE LIABLE FOR INCIDENTAL OR CONSEQUENTIAL DAMAGES OF ANY NATURE WHATSOEVER, INCLUDING BUT NOT LIMITED TO LOST PROFITS OR COMMERCIAL LOSS TO THE FULL EXTENT THOSE DAMAGES CAN BE DISCLAIMED BY LAW.

Some countries/states do not allow the exclusion or limitation of incidental or consequential damages, or limitation of the duration of implied warranties, so the preceding limitations or exclusions may not apply to you.

The warranty provided does not affect the consumer's statutory rights under applicable legislation in force, nor the consumer's rights against the dealer arising from their sales / purchase contract.

***Geographical scope of the warranty**

If you have purchased your Product in a country member of the European Economic Area (EEA) or in Switzerland or the Republic

of Turkey, and such Product was intended for sale in the EEA or in Switzerland or in Turkey, you can have your Product serviced in any EEA country or in Switzerland or in Turkey, under the warranty conditions prevailing in the country in which you require servicing, provided that an identical Product is sold in such country by an authorised Sony Ericsson distributor. To find out if your Product is sold in the country you are in, please call the local Sony Ericsson Call Center. Please observe that certain services may not be available outside the country of original purchase, for example, due to the fact that your Product may have an interior or exterior which is different from equivalent models sold in other countries. Please note in addition that it may sometimes not be possible to repair SIM-locked Products.

** In some countries/regions additional information (such as a valid warranty card) may be requested.

Trademarks and acknowledgements

The Liquid Identity logo and Xperia are trademarks or registered trademarks of Sony Ericsson Mobile Communications AB.

Sony is a trademark or a registered trademark of Sony Corporation.

Ericsson is a trademark or registered trademark of Telefonaktiebolaget LM Ericsson.

Bluetooth is a trademark or a registered trademark of Bluetooth SIG Inc. and any use of such mark by Sony Ericsson is under license.

Other product and company names mentioned herein may be the trademarks of their respective owners.

Any rights not expressly granted herein are reserved.

Support

Anguilla	1-800-080-9518 (Toll Free)	questions.CO@support.sonyericsson.com
Antigua and Barbuda	1-800-081-9518 (Toll Free)	questions.CO@support.sonyericsson.com
Argentina	0800-333-7427 (número gratuito)	questions.CO@support.sonyericsson.com
Australia	1300 650-050 (Toll Free)	questions.AU@support.sonyericsson.com
The Bahamas	1-800-205-6062 (Toll Free)	questions.CO@support.sonyericsson.com
Barbados	1-800-082-9518 (Toll Free)	questions.CO@support.sonyericsson.com
Belgique/ België	02-0745 1611	questions.BE@support.sonyericsson.com
Belize	AN 815, PIN 5597 (Toll Free)	questions.CO@support.sonyericsson.com
Bermuda	1-800-083-9518 (Toll Free)	questions.CO@support.sonyericsson.com
Bolivia	800-100-542 (número gratuito)	questions.CO@support.sonyericsson.com
Brasil	4001-0444 (ligação gratuita)	questions.BR@support.sonyericsson.com
Canada	1 866 766 9374 (Toll Free / sans frais)	questions.CA@support.sonyericsson.com
Cayman Islands	1-800-084-9518 (Toll Free)	questions.CO@support.sonyericsson.com
Central and Southern Africa	+27 11 506 0123	questions.CF@support.sonyericsson.com
Česká republika	0844 550 055	questions.CZ@support.sonyericsson.com
Chile	800-646-425 (número gratuito)	questions.CO@support.sonyericsson.com
Colombia	01800-0966-080 (número gratuito)	questions.CO@support.sonyericsson.com
Costa Rica	0 800 011 0400 (número gratuito)	questions.CO@support.sonyericsson.com
Danmark	3331 2828	questions.DK@support.sonyericsson.com

Deutschland	0180 534 2020 (ortsübliche Gebühren)	questions.DE@support.sonyericsson.com
Dominica	1-800-085-9518 (Toll Free)	questions.CO@support.sonyericsson.com
Ecuador	1-800-0102-50 (número gratuito)	questions.CO@support.sonyericsson.com
Eesti	06 032 032	questions.EE@support.sonyericsson.com
Egypt/مصر	16727	questions.EG@support.sonyericsson.com
Ελλάδα	801 11 810 810 +30 210 899 19 19 (από κινητό τηλέφωνο)	questions.GR@support.sonyericsson.com
El Salvador	800-6323 (número gratuito)	questions.CO@support.sonyericsson.com
España	902 180 576 (tarifa local)	questions.ES@support.sonyericsson.com
France	09 69 32 21 21 09 69 32 21 22 (Xperia™ uniquement)	questions.FR@support.sonyericsson.com
Guatemala	1-800-300-0057 (número gratuito)	questions.CO@support.sonyericsson.com
Haïti/Ayiti	AN 193, PIN 5598 (numéro gratuit / nimewo gratis)	questions.CO@support.sonyericsson.com
Honduras	AN 8000122, PIN 5599 (número gratuito)	questions.CO@support.sonyericsson.com
Hong Kong/香港	+852 8203 8863	questions.HK@support.sonyericsson.com
Hrvatska	062 000 000	questions.HR@support.sonyericsson.com
India/भारत	1800 11 1800 (Toll Free) +91 (011) 39011111	questions.IN@support.sonyericsson.com
Indonesia	021 2701388	questions.ID@support.sonyericsson.com
Irland	1850 545 888 (Local rate)	questions.IE@support.sonyericsson.com
Italia	06 48895206 (tariffa locale)	questions.IT@support.sonyericsson.com
Jamaica	1-800-442-3471 (Toll Free)	questions.CO@support.sonyericsson.com

Kύπρος/ Kibris	0800 90 909	questions.CY@support.sonyericsson.com
Latvija	67 21 43 01	questions.LV@support.sonyericsson.com
Lietuva	8 700 55030	questions.LT@support.sonyericsson.com
Magyarország	01 880 47 47	questions.HU@support.sonyericsson.com
Malaysia	1800-88-9900 (Toll Free / bebas tol)	questions.MY@support.sonyericsson.com
Maroc/ المغرب	+212 2 2958 344	questions.MA@support.sonyericsson.com
México	0 1800 000 4722 (número gratuito)	questions.MX@support.sonyericsson.com
Nederland	0900 8998318	questions.NL@support.sonyericsson.com
Nederlandse Antillen	001-866-509-8660 (gratis nummer)	questions.CO@support.sonyericsson.com
New Zealand	0800-100-150 (Toll Free)	questions.NZ@support.sonyericsson.com
Nicaragua	AN 1800-0166, PIN 5600 (número gratuito)	questions.CO@support.sonyericsson.com
Norge	815 00 840 (lokaltakst)	questions.NO@support.sonyericsson.com
Österreich	0810 200 245	questions.AT@support.sonyericsson.com
Pakistan/ پاکستان	021 - 111 22 55 73	questions.PK@support.sonyericsson.com
Panamá	00800-787-0009 (número gratuito)	questions.CO@support.sonyericsson.com
Paraguay	009 800 54 20032 (número gratuito)	questions.CO@support.sonyericsson.com
Perú	0800-532-38 (número gratuito)	questions.CO@support.sonyericsson.com
Philippines/ Pilipinas	+63 2 7891860	questions.PH@support.sonyericsson.com
Polska	+48 22 22 77 444	questions.PL@support.sonyericsson.com
Portugal	808 204 466 (chamada local)	questions.PT@support.sonyericsson.com
República Dominicana	1-800-751-3370 (número gratuito)	questions.CO@support.sonyericsson.com
România	+40 21 401 0401	questions.RO@support.sonyericsson.com
Saint Kitts and Nevis	1-800-087-9518 (Toll Free)	questions.CO@support.sonyericsson.com

Saint Vincent and the Grenadines	1-800-088-9518 (Toll Free)	questions.CO@support.sonyericsson.com
Schweiz/ Suisse/ Svizzera	0848 824 040	questions.CH@support.sonyericsson.com
Singapore	+65 6744 0733	questions.SG@support.sonyericsson.com
Slovensko	02 5443 6443	questions.SK@support.sonyericsson.com
South Africa	0861 632222	questions.ZA@support.sonyericsson.com
South Korea/ 대한민국	(+82) 1588 4170	questions.KO@support.sonyericsson.com
Suomi	09 299 2000	questions.FI@support.sonyericsson.com
Sverige	013 24 45 00 (lokal taxa)	questions.SE@support.sonyericsson.com
Trinidad and Tobago	1-800-080-9521 (Toll Free)	questions.CO@support.sonyericsson.com
Türkiye	+90 212 473 77 77	questions.TR@support.sonyericsson.com
United Kingdom	08705 237 237 (Local rate)	questions.GB@support.sonyericsson.com
United States	1 866 766 9374	questions.US@support.sonyericsson.com
Uruguay	000-401-787-013 (número gratuito)	questions.CO@support.sonyericsson.com
Venezuela	0-800-1-00-2250 (número gratuito)	questions.CO@support.sonyericsson.com
Việt Nam	1900 1525 (miễn phí)	questions.VN@support.sonyericsson.com
Беларусь	8 82 00 361 0001	questions.BY@support.sonyericsson.com
България	0800 1 8778	questions.BG@support.sonyericsson.com
Россия	+7 (495) 7870986	questions.RU@support.sonyericsson.com
Україна	(+380) 44 590 1515	questions.UA@support.sonyericsson.com
الأردن	+971 4 3919 880	questions.JO@support.sonyericsson.com
الإمارات العربية المتحدة	+971 4 3919 880 (UAE)	questions.AE@support.sonyericsson.com
الكويت	+971 4 3919 880	questions.KW@support.sonyericsson.com
المملكة العربية السعودية	800-8200-727	questions.SA@support.sonyericsson.com
中国	+86 400 810 0000	questions.CN@support.sonyericsson.com
台灣	+886 2 25625511	questions.TW@support.sonyericsson.com
ไทย	02 2483 030	questions.TH@support.sonyericsson.com

www.sonyericsson.com



Sony Ericsson

Sony Ericsson Mobile Communications AB
SE-221 88 Lund, Sweden

1222-9269.1