



Company Internal REPORT

Prepared (also subject responsible if other)

BA/SEM/BGLINS Robert Carr

No.

BGLI08:071.

Approved

Checked

Date

Rev

Reference

LD/SEMC/BGLI/NC Peter Lindeborg

01/02/08

31/01/08

A

File

Report issued by Accredited SAR Laboratory

For

PY7A1032052 (Z555a)

Date of test: 16,21,22,29 January 2008

Laboratory: Sony Ericsson SAR Test Laboratory
Sony Ericsson Mobile Communications AB
Maplewood, Chineham Business Park
Basingstoke, RG24 8YB,
England

Testing Engineer: Robert Carr
Robert.Carr@sonyericsson.com
+44 1256 77 48 95

Handwritten signature: ROBERT CARR

Testing Approval Peter Lindeborg
Peter.Lindeborg@sonyericsson.com
+46462126180

Handwritten signature: PL Lindeborg

Statement of Compliance

Sony Ericsson Mobile Communications AB declares under its sole responsibility that the product

Sony Ericsson Type : AAB-1032052-BV; FCC ID : PY7A1032052; IC:4170B-A1032052

To which this declaration relates, is in conformity with the appropriate RF exposure standards recommendations and guidelines. It also declares that the product was tested in accordance with the appropriate measurement standards, guidelines and recommended practices. Any deviations from these standards, guidelines and recommended practices are noted below:

(None)

This laboratory is accredited to ISO/IEC 17025 (SWEDAC accreditation no. 1847).



Laboratories are accredited by the Swedish Board for Accreditation and Conformity Assessment (SWEDAC) under the terms of Swedish legislation. The accredited laboratory activities meet the requirements in SS-EN ISO/IEC 17025 (2005). This report may not be reproduced other than in full, except with the prior written approval of the issuing laboratory.

The results and statements contained herein relate only to the items tested. The names of individuals involved may be mentioned only in connection with the statements or results from this report.

Sony Ericsson encourages all feedback, both positive and negative, on this report.

© Sony Ericsson Mobile Communication AB, 2008

**Company Internal
REPORT**

Prepared (also subject responsible if other)

BA/SEM/BGLINS Robert Carr

Approved

LD/SEMC/BGLI/NC Peter Lindeborg

Checked

01/02/08

No.

BGLI08:071.

Date

31/01/08

Rev

A

Reference

File
Table of contents

1	INTRODUCTION	3
2	DEVICE UNDER TEST	3
2.1	SAMPLES	3
2.2	ANTENNA DESCRIPTION	3
2.3	DEVICE DESCRIPTION	4
3	TEST EQUIPMENT.....	5
3.1	DOSIMETRIC SYSTEM	5
3.2	ADDITIONAL EQUIPMENT	5
4	ELECTRICAL PARAMETERS ON THE TISSUE SIMULATING LIQUID	6
5	SYSTEM ACCURACY VERIFICATION	6
6	SAR MEASUREMENT UNCERTAINTY	7
7	TEST RESULTS	8
8	REFERENCES	10
9	APPENDIX.....	11
9.1	PHOTOGRAPHS OF THE DEVICE UNDER TEST.....	11
9.2	DEVICE POSITION ON SAM TWIN PHANTOM.....	12
9.3	PHOTOGRAPHS OF TSL FLUID DEPTHS	13
10	ATTACHMENTS.....	15



Prepared (also subject responsible if other)

BA/SEM/BGLINS Robert Carr

Approved

LD/SEMC/BGLI/NC Peter Lindeborg

Checked

01/02/08

No.

BGLI08:071.

Date

31/01/08

Rev

A

Reference

File

1 Introduction

In this test report, compliance of the Sony Ericsson PY7A1032052 (Z555a) portable telephone with RF safety guidelines is demonstrated. The applicable RF safety guidelines and the SAR measurement specifications used for the test are described in the *SAR Measurement Specifications of Wireless Handsets* [1].

2 Device Under Test

2.1 Samples

For the purpose of the test two different color samples were used to maximise the SAR value across the different frequency bands.

2.2 Antenna Description

Type	Built in	
Location	Bottom of phone	
Dimensions	Max length	11mm
	Max width	44mm
Configuration	Semi-PIFA	

**Company Internal
REPORT**

Prepared (also subject responsible if other)

BA/SEM/BGLINS Robert Carr

Approved

LD/SEMC/BGLI/NC Peter Lindeborg

Checked

01/02/08

No.

BGLI08:071.

Date

31/01/08

Rev

A

Reference

File

2.3 Device description

Device model	PY7A1032052					
Market name	Z555a					
Serial numbers (EUT #)	CB510VZPPS (#10204)			CB510VYH1K (#10203)		
Mode	GSM 850			GSM 1900		
Crest factor	8.3			8.3		
Multiple access scheme	TDMA			TDMA		
Maximum output power setting [dBm]	Ch. 128	Ch. 190	Ch. 251	Ch. 512	Ch. 661	Ch. 810
	33.4	33.5	33.5	30.5	30.5	30.5
Factory tolerance in power setting	±0.5 dB			±0.5 dB		
Maximum peak output power [dBm]	33.5	33.5	33.5	30.5	30.5	30.5
Mode	GSM850 – GPRS/EDGE 2Tx			GSM1900 – GPRS/EDGE 2Tx		
Crest factor	4.15			4.15		
Multiple access scheme	TDMA			TDMA		
Maximum output power setting [dBm]	Ch. 128	Ch. 190	Ch. 251	Ch. 512	Ch. 661	Ch. 810
	33.4	33.5	33.5	30.5	30.5	30.5
Factory tolerance in power setting	±0.5 dB			±0.5 dB		
Maximum peak output power [dBm]	33.5	33.5	33.5	30.5	30.5	30.5
Transmitting frequency range [MHz]	824.2 - 848.8			1850.2 - 1909.8		
GPRS Multislot class	10					
GPRS Capability class	B					
Prototype or production unit	Preproduction (HW:AP2)					
Device category	Portable					
RF exposure environment	General population / uncontrolled					

**Company Internal
REPORT**

Prepared (also subject responsible if other)

BA/SEM/BGLINS Robert Carr

Approved

LD/SEMC/BGLI/NC Peter Lindeborg

Checked

01/02/08

No.

BGLI08:071.

Date

31/01/08

Rev

A

Reference

File

3 Test equipment

3.1 Dosimetric system

SAR measurements were made using the DASY4 professional system (software version 4.7, Built 44) with SAM twin phantom, manufactured by Schmid & Partner Engineering AG (SPEAG). The list of calibrated equipment is given below.

Description	Serial Number	Due Date
DASY4 DAE3	448	15-11-2008
E-field probe ET3DV6	1610	14-11-2008
Dipole Validation Kit, D835V2	442	06-12-2008
Dipole Validation Kit, D1900V2	539	12-12-2008

3.2 Additional equipment

Description	Inventory Number	Due Date
Signal generator R&S SMY 02	3.094	24-04-08
Directional coupler HP778D	15.233	None
Power meter R&S NRVD	4.073	24-04-08
Power sensor R&S NRV-Z5	4.074	24-04-08
Power sensor R&S NRV-Z5	4.076	24-04-08
Network analyzer Agilent 8719D	2.022	23-04-08
Dielectric probe kit HP8507C	14.046	Self Cal
R&S CMU200	20011497	08-05-08

**Company Internal
REPORT**

Prepared (also subject responsible if other)

BA/SEM/BGLINS Robert Carr

Approved

LD/SEMC/BGLI/NC Peter Lindeborg

Checked

01/02/08

No.

BGLI08:071.

Date

31/01/08

Rev

A

Reference

File

4 Electrical parameters on the tissue simulating liquid

Prior to conducting SAR measurements, the relative permittivity, ϵ_r , and the conductivity, σ , of the tissue simulating liquids were measured with the dielectric probe kit. These values are shown in the table below. The mass density, ρ , entered into the DASY software is also given. Recommended parameters for permittivity ϵ_r , conductivity σ and mass density ρ are also shown.

f [MHz]	Tissue type	Measured / Recommended	Dielectric Parameters		Density
			ϵ_r	σ [S/m]	ρ [g/cm ³]
850	Head	Measured, 16-01-08	39.66	0.87	1.00
		Recommended	41.50	0.90	1.00
	Body	Measured, 21-01-08	55.14	0.97	1.00
		Recommended	55.20	0.97	1.00
1900	Head	Measured, 22-01-08	39.46	1.47	1.00
		Recommended	40.00	1.40	1.00
	Body	Measured, 29-01-08	50.97	1.59	1.00
		Recommended	53.30	1.52	1.00

5 System accuracy verification

A system accuracy verification of the DASY4 was performed using the dipole validation kit listed in section 3.1. The system verification test was conducted on the same day as the measurement of the DUT. The measurements were made at an ambient temperature of 22-24.3°C and humidity 30-40.3%. The obtained results are displayed in the table below.

RF noise had been measured in the liquid when all RF equipment in lab was switched off. Measured value was 0.00000289 mW/g in 1g mass.

f [MHz]	Tissue type	Measured / Reference	SAR [W/kg] 1g / 10g	Dielectric Parameters		Density	Liquid T [°C]
				ϵ_r	σ [S/m]	ρ [g/cm ³]	
850	Head	Measured, 16-01-08	9.2 / 6.1	39.66	0.87	1.00	22.1
		Reference	9.4 / 6.2	41.50	0.90	1.00	22.0
	Body	Measured, 21-01-08	9.5 / 6.3	55.14	0.97	1.00	21.9
		Reference	9.7 / 6.5	55.20	0.97	1.00	22.0
1900	Head	Measured, 22-01-08	39.0 / 20.1	39.46	1.47	1.00	22.0
		Reference	35.9 / 19.1	40.00	1.40	1.00	22.0
	Body	Measured, 29-01-08	40.4 / 21	50.97	1.59	1.00	21.7
		Reference	37.0 / 19.8	53.30	1.52	1.00	22.0

Prepared (also subject responsible if other)

BA/SEM/BGLINS Robert Carr

Approved

LD/SEMC/BGLI/NC Peter Lindeborg

Checked

01/02/08

No.

BGLI08:071.

Date

31/01/08

Rev

A

Reference

File

6 SAR measurement uncertainty

DASY4 SAR measurement uncertainty evaluation for Sony Ericsson PY7A1032052 phone According to IEEE 1528

Uncertainty Component	Uncer. (%)	Prob Dist.	Div.	C _i	1g mass
Measurement System					
Probe Calibration	±5.9	N	1	1	±5.9
Axial Isotropy	±4.7	R	√3	0.7	±1.9
Spherical Isotropy	±9.6	R	√3	0.7	±3.9
Boundary effect	±1.0	R	√3	1	±0.6
Probe linearity	±4.7	R	√3	1	±2.7
Detection limit	±1.0	R	√3	1	±0.6
Readout electronics	±0.3	N	1	1	±0.3
Response time	±0.8	R	√3	1	±0.5
Integration time	±2.6	R	√3	1	±1.5
RF Ambient Conditions	±3.0	R	√3	1	±1.7
Mech. Constraints of robot	±0.4	R	√3	1	±0.2
Probe positioning	±2.9	R	√3	1	±1.7
Extrap, interpolation and integration	±1.0	R	√3	1	±0.6
<i>Measurement System Uncertainty</i>					±8.4
Test Sample Related					
Device positioning	±3.5	N	1	1	±3.5
Device holder uncertainty	±3.5	N	1	1	±3.5
Power drift	±5.0	R	√3	1	±2.9
<i>Test Sample Related Uncertainty</i>					±5.5
Phantom and Tissue Parameters					
Phantom uncertainty	±4.0	R	√3	1	±2.3
Liquid conductivity (measured)	±2.5	R	1	0.64	±1.6
Liquid conductivity (target)	±5.0	R	√3	0.64	±1.8
Liquid Permittivity (measured)	±2.5	R	1	0.6	±1.5
Liquid Permittivity (target)	±5.0	R	√3	0.6	±1.7
<i>Phantom and Tissue Parameters Uncertainty</i>					±4.1
Combined standard uncertainty					±10.8
Extended standard uncertainty (k=2)					±21.6

**Company Internal
REPORT**

Prepared (also subject responsible if other)

BA/SEM/BGLINS Robert Carr

Approved

LD/SEMC/BGLI/NC Peter Lindeborg

Checked

01/02/08

No.

BGLI08:071.

Date

31/01/08

Rev

A

Reference

File

7 Test results

The measured 1-gram averaged SAR values of the device towards the head and body are provided in Table 1 and Table 2. The ambient humidity and temperature of test facility were (30-40.3) % and (22-24.3) °C respectively. The depth of the head and body tissue simulating liquids were greater than 15.5cm. A base station simulator was used to control the device during the SAR measurements. The phone was supplied with a fully-charged battery for each measurement. For head measurement, the device was tested on the right-hand phantom and the left-hand phantom in two different phones position, cheek (touch) and tilt (cheek + 15deg). For all modes, the device was tested at the lowest, middle and highest frequencies in the transmission band.

For body measurement the DUT was tested with the antenna (back) and display (front) towards the phantom flat section with 15 mm distance in both speech and data mode. Available data modes were GPRS and EDGE. The device was tested at the lowest, middle and highest frequencies in the transmission band. For portable hands free (PHF) usage the Sony Ericsson head set HPB-60 was connected to the DUT, and for Bluetooth calls the DUT was paired with Sony Ericsson HBH-DS970.

Band	Channel	Power [dBm]	Position	Liquid T [°C]	Measured SAR [W/kg]	
					Left-hand 1g mass	Right-hand 1g mass
GSM 850	128	33.4	Cheek	22.1	0.58	0.48
			Tilt	-	-	-
	190	33.5	Cheek	22.1	0.67	0.55
			Tilt	22.1	0.25	0.23
	251	33.5	Cheek	22.1	0.65	0.53
			Tilt	-	-	-
GSM 1900	512	30.5	Cheek	22.0	0.24	0.35
			Tilt	-	-	-
	661	30.5	Cheek	22.0	0.29	0.38
			Tilt	22.0	0.06	0.11
	810	30.5	Cheek	22.0	0.27	0.35
			Tilt	--	-	-

Table1: Head SAR measurement results for Sony Ericsson PY7A1032052 telephone at highest possible output power.



Sony Ericsson

Company Internal
REPORT

Prepared (also subject responsible if other)

BA/SEM/BGLINS Robert Carr

Approved

LD/SEMC/BGLI/NC Peter Lindeborg

Checked

01/02/08

No.

BGLI08:071.

Date

31/01/08

Rev

A

Reference

File

Band	Channel	Power [dBm]	Position / Mode	Liquid T [°C]	Measured SAR 1g mass [W/kg]
GSM 850	128	33.4	Back GPRS	21.9	0.63
			Front GPRS	21.9	0.27
		27.4	Back EDGE	21.9	0.16
		33.4	Back Bluetooth	21.9	0.33
	Back PHF		21.9	0.29	
	190	33.5	Back GPRS	21.9	0.51
			Back Bluetooth	21.9	0.27
	251	33.5	Back GPRS	21.9	0.43
Back Bluetooth			21.9	0.23	
GSM 1900	512	30.5	Back GPRS	21.4	0.88
			Front GPRS	21.4	0.26
		27.0	Back EDGE	21.4	0.30
		30.5	Back Bluetooth	21.4	0.46
	Back PHF		21.4	0.54	
	661	30.5	Back GPRS	21.4	0.80
			Back Bluetooth	21.4	0.42
	810	30.5	Back GPRS	21.4	0.66
Back Bluetooth			21.4	0.35	

Table2: Body SAR measurement results for Sony Ericsson PY7A1032052 telephone at highest possible output power.

**Company Internal
REPORT**

Prepared (also subject responsible if other)

BA/SEM/BGLINS Robert Carr

Approved

LD/SEMC/BGLI/NC Peter Lindeborg

Checked

01/02/08

No.

BGLI08:071.

Date

31/01/08

Rev

A

Reference

File

8 References

[1] R.Plicanic, "SAR Measurement Specification of Wireless Handsets", Sony Ericsson SAR Test Laboratory internal document GUG/N 03:141

[2] FCC, "Evaluating Compliance with FCC Guidelines for Human Exposure to Radio Frequency Electromagnetic Fields: Additional Information for Evaluating Compliance of Mobile and Portable Devices with FCC Limits for Human Exposure to Radio Frequency Emissions," Supplement C (Edition 01-01) to OET Bulletin 65 (Edition 97- 01).

[3] IEEE, "Recommended Practice for Determining the Peak Spatial-Average Specific Absorption Rate (SAR) in the Human Body Due to Wireless Communications Devices: Experimental Techniques," Std 1528-2003, June, 2003.

[4] IEC, "Procedure to determine the specific absorption rate (SAR) for hand-held devices used in close proximity to the ear (frequency range of 300MHz to 3GHz," Std. 62209-1, February, 2005.

Prepared (also subject responsible if other)

BA/SEM/BGLINS Robert Carr

Approved

LD/SEMC/BGLI/NC Peter Lindeborg

Checked

01/02/08

No.

BGLI08:071.

Date

31/01/08

Rev

A

Reference

File

9 Appendix

9.1 Photographs of the device under test



Front & Back

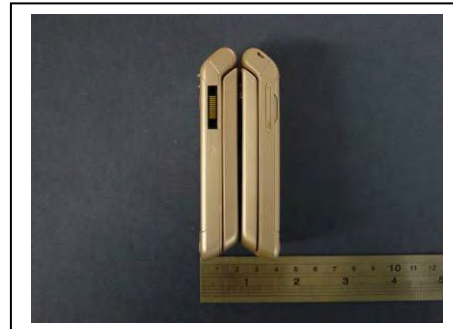

Sides



Back side with battery



Top and Bottom



Samples Front



Samples Back

Prepared (also subject responsible if other)

BA/SEM/BGLINS Robert Carr

Approved

LD/SEMC/BGLI/NC Peter Lindeborg

Checked

01/02/08

Company Internal
REPORT

No.

BGLI08:071.

Date

31/01/08

Rev

A

Reference

File

9.2 Device position on SAM Twin Phantom

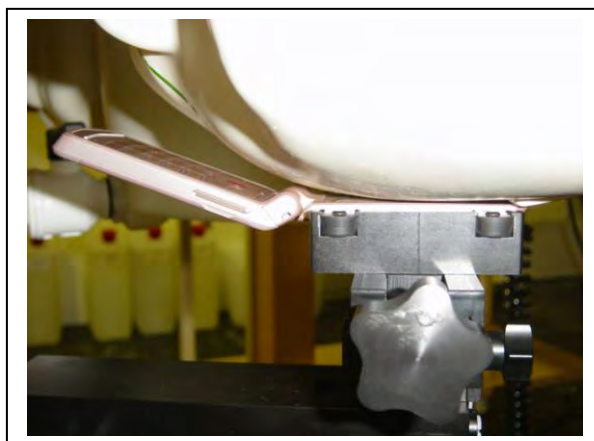
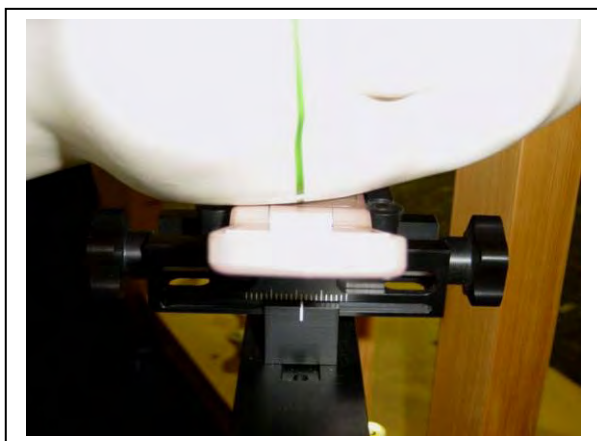

Device position against the head: Cheek (touch) phone position

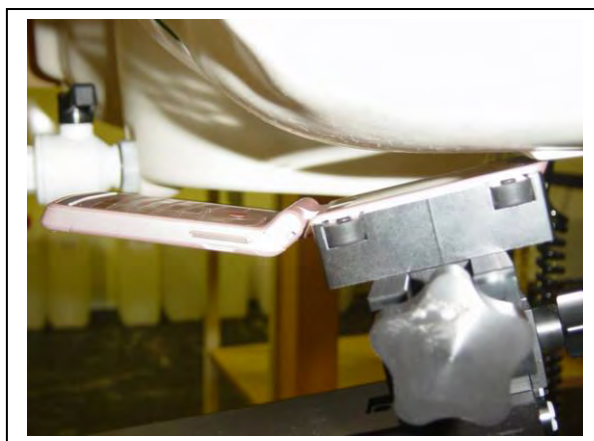
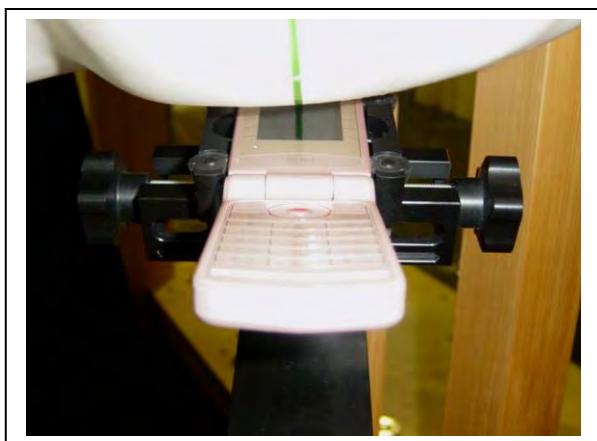

Device position against the head: Tilt (cheek+15deg) phone position

Prepared (also subject responsible if other)

BA/SEM/BGLINS Robert Carr

Approved

LD/SEMC/BGLI/NC Peter Lindeborg

Checked

01/02/08

Company Internal
REPORT

No.

BGLI08:071.

Date

31/01/08

Rev

A

Reference

File

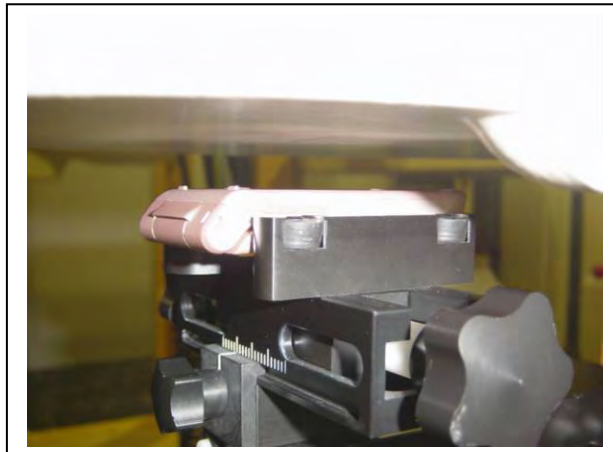

Device position against the body: 15mm distance from Phantom.

9.3 Photographs of TSL Fluid Depths

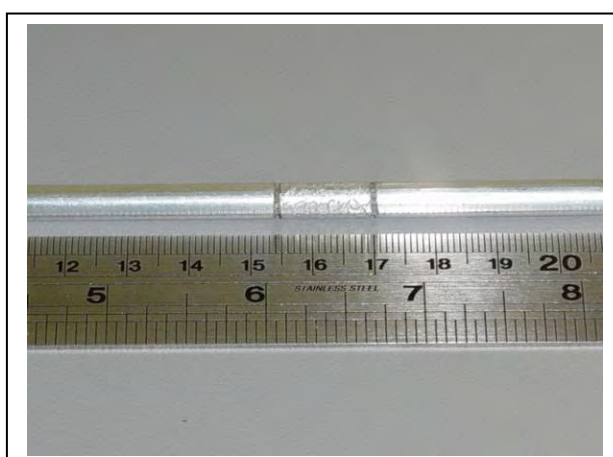
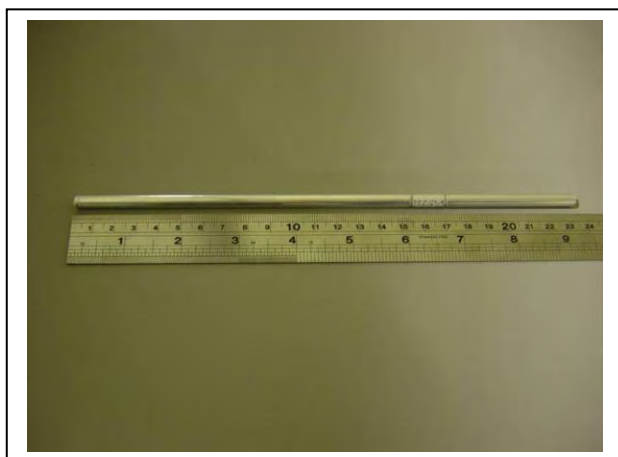

Pictures to show depth gauge used for measuring TSL depth.
Note: The low end of the scale is a depth of 15.5 cm.

Company Internal
REPORT

Prepared (also subject responsible if other)

BA/SEM/BGLINS Robert Carr

Approved

LD/SEMC/BGLI/NC Peter Lindeborg

Checked

01/02/08

No.

BGLI08:071.

Date

31/01/08

Rev

A

Reference

File

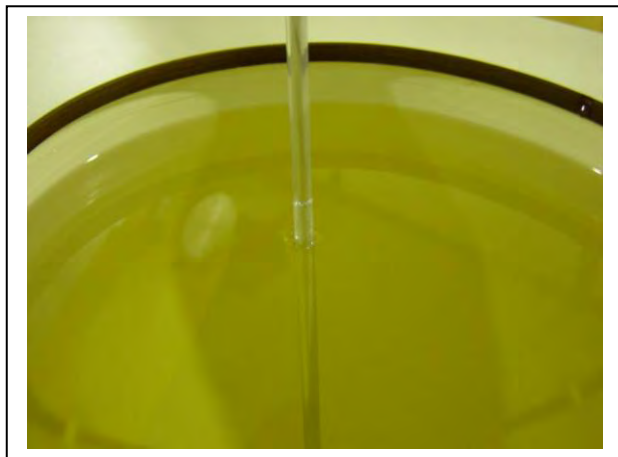

850 Head

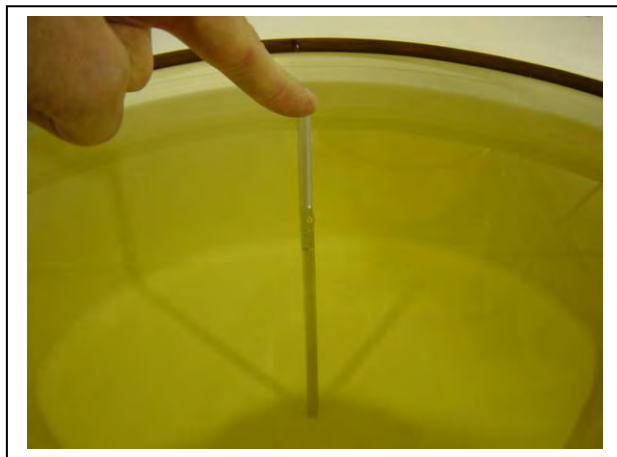

850 Body



1900 Head



1900 Body

Pictures showing Phantom fluid depths.

**Company Internal
REPORT**

Prepared (also subject responsible if other)

BA/SEM/BGLINS Robert Carr

Approved

LD/SEMC/BGLI/NC Peter Lindeborg

Checked

01/02/08

No.

BGLI08:071.

Date

31/01/08

Rev

A

Reference

File**10 Attachments**

- Measurement plots and system validation
- Dipole calibration

Date/Time: 1/22/2008 12:12:11 PM

Test Laboratory: Sony Ericsson Mobile Communications International AB

Validation-D1900-22-01-08**DUT: Dipole 1900 MHz; Type: D1900V2; Serial: D1900V2 - SN:539**

Communication System: CW; Frequency: 1900 MHz; Duty Cycle: 1:1

Medium parameters used: $f = 1900$ MHz; $\sigma = 1.47$ mho/m; $\epsilon_r = 39.5$; $\rho = 1000$ kg/m³

Phantom section: Flat Section

Measurement Standard: DAS4 (High Precision Assessment)

DASY4 Configuration:

- Probe: ET3DV6 - SN1610; ConvF(5.18, 5.18, 5.18); Calibrated: 11/14/2007
 - Sensor-Surface: 4mm (Mechanical Surface Detection)
 - Electronics: DAE3 Sn448; Calibrated: 15/11/2007
 - Phantom: SAM-1; Type: SAM; Serial: 1437
 - Measurement SW: DAS4, V4.7 Build 53; Postprocessing SW: SEMCAD, V1.8 Build 172
- d=10mm, Pin=250mW/Area Scan (61x61x1):** Measurement grid: dx=15mm, dy=15mm
Maximum value of SAR (interpolated) = 11.9 mW/g
- d=10mm, Pin=250mW/Zoom Scan (7x7x7) (7x7x7)/Cube 0:** Measurement grid:
dx=5mm, dy=5mm, dz=5mm
Reference Value = 88.4 V/m; Power Drift = 0.129 dB
Peak SAR (extrapolated) = 18.4 W/kg
SAR(1 g) = 9.74 mW/g; SAR(10 g) = 5.03 mW/g
Maximum value of SAR (measured) = 11.0 mW/g

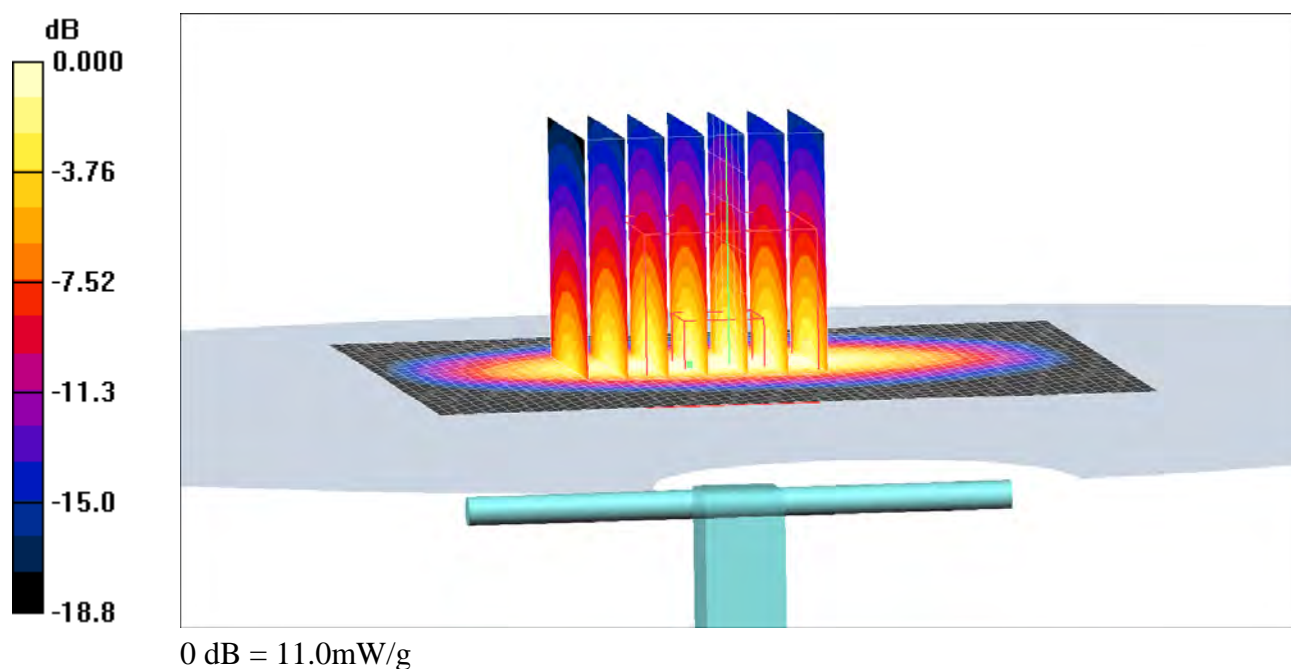

Date/Time: 1/29/2008 1:58:08 PM

Test Laboratory: Sony Ericsson Mobile Communications International AB

Validation-D1900-29-01-08-Body**DUT: Dipole 1900 MHz; Type: D1900V2; Serial: D1900V2 - SN:539**

Communication System: CW; Frequency: 1900 MHz; Duty Cycle: 1:1

Medium parameters used: $f = 1900$ MHz; $\sigma = 1.59$ mho/m; $\epsilon_r = 51$; $\rho = 1000$ kg/m³

Phantom section: Flat Section

Measurement Standard: DAS4 (High Precision Assessment)

DASY4 Configuration:

- Probe: ET3DV6 - SN1610; ConvF(4.68, 4.68, 4.68); Calibrated: 11/14/2007
 - Sensor-Surface: 4mm (Mechanical Surface Detection)
 - Electronics: DAE3 Sn448; Calibrated: 15/11/2007
 - Phantom: SAM-3; Type: SAM; Serial: 1436
 - Measurement SW: DAS4, V4.7 Build 53; Postprocessing SW: SEMCAD, V1.8 Build 172
- d=10mm, Pin=250mW/Area Scan (61x61x1):** Measurement grid: dx=15mm, dy=15mm
Maximum value of SAR (interpolated) = 12.8 mW/g
- d=10mm, Pin=250mW/Zoom Scan (7x7x7) (7x7x7)/Cube 0:** Measurement grid:
dx=5mm, dy=5mm, dz=5mm
Reference Value = 86.4 V/m; Power Drift = 0.101 dB
Peak SAR (extrapolated) = 18.5 W/kg
SAR(1 g) = 10.1 mW/g; SAR(10 g) = 5.24 mW/g
Maximum value of SAR (measured) = 11.3 mW/g

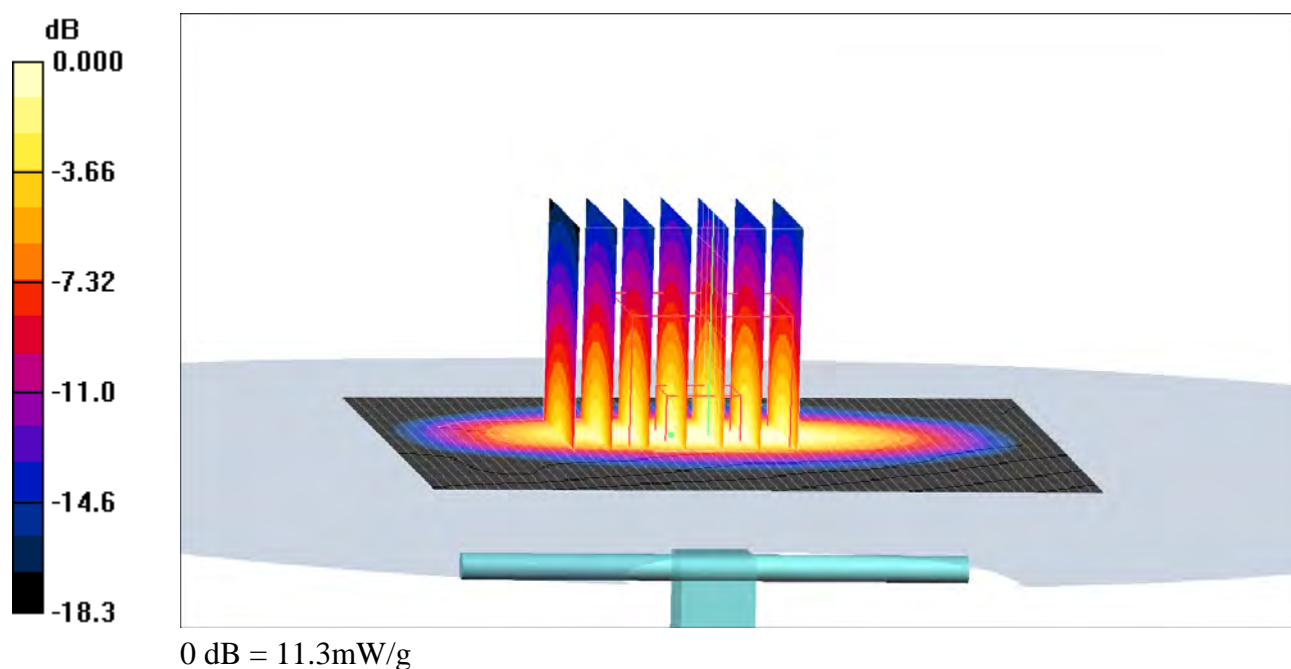

Date/Time: 1/22/2008 4:40:37 PM

Test Laboratory: Sony Ericsson Mobile Communications International AB

Magdalena-RightHandSide-GSM1900-Tilt-Middle**DUT: Magdalena; Type: DUT; Serial: #10203**

Communication System: DCS 1900; Frequency: 1880 MHz; Duty Cycle: 1:8.3

Medium parameters used: $f = 1880$ MHz; $\sigma = 1.45$ mho/m; $\epsilon_r = 39.5$; $\rho = 1000$ kg/m³

Phantom section: Right Section

Measurement Standard: DAS4 (High Precision Assessment)

DASY4 Configuration:

- Probe: ET3DV6 - SN1610; ConvF(5.18, 5.18, 5.18); Calibrated: 11/14/2007
 - Sensor-Surface: 4mm (Mechanical Surface Detection)
 - Electronics: DAE3 Sn448; Calibrated: 15/11/2007
 - Phantom: SAM-1; Type: SAM; Serial: 1437
 - Measurement SW: DAS4, V4.7 Build 53; Postprocessing SW: SEMCAD, V1.8 Build 172
- Tilt position - Middle/Area Scan (71x131x1):** Measurement grid: dx=10mm, dy=10mm
Maximum value of SAR (interpolated) = 0.118 mW/g
- Tilt position - Middle/Zoom Scan (5x5x7) (5x5x7)/Cube 0:** Measurement grid:
dx=8mm, dy=8mm, dz=5mm
Reference Value = 6.39 V/m; Power Drift = 0.107 dB
Peak SAR (extrapolated) = 0.176 W/kg
SAR(1 g) = 0.107 mW/g; SAR(10 g) = 0.063 mW/g
Maximum value of SAR (measured) = 0.113 mW/g

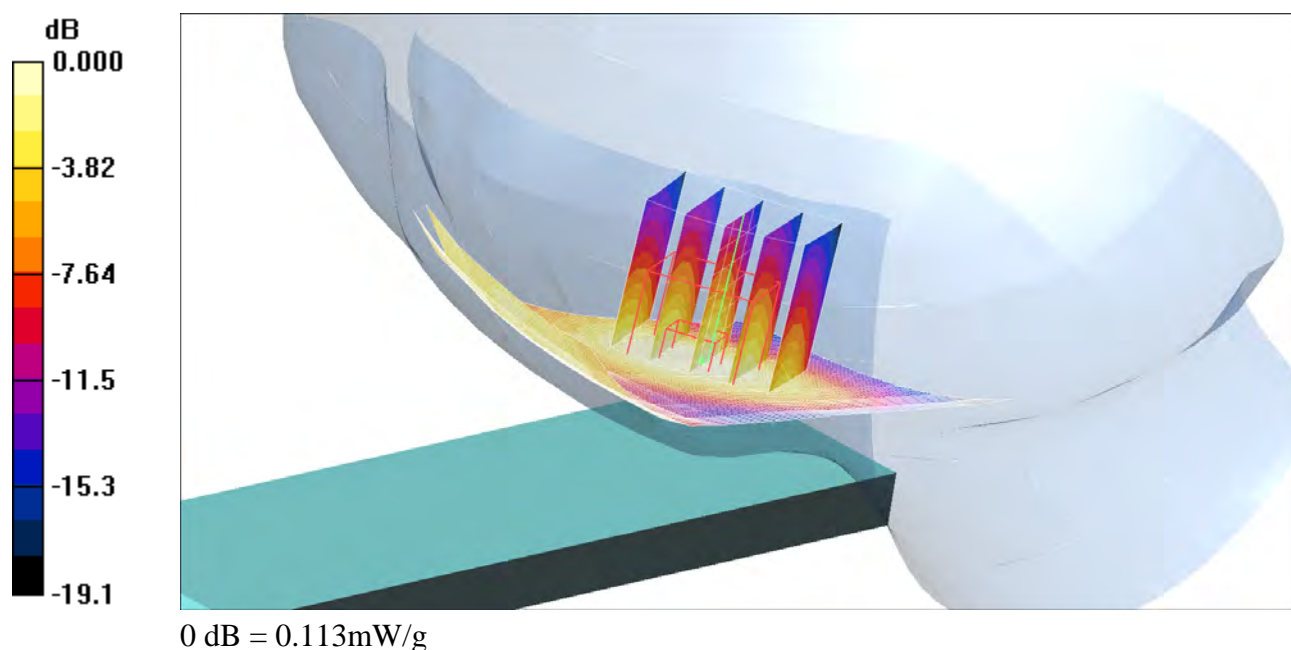

Date/Time: 1/22/2008 4:21:41 PM

Test Laboratory: Sony Ericsson Mobile Communications International AB

Magdalena-RightHandSide-GSM1900-Touch-High**DUT: Magdalena; Type: DUT; Serial: #10203**

Communication System: DCS 1900; Frequency: 1909.8 MHz; Duty Cycle: 1:8.3

Medium parameters used: $f = 1909.8$ MHz; $\sigma = 1.49$ mho/m; $\epsilon_r = 39.4$; $\rho = 1000$ kg/m³

Phantom section: Right Section

Measurement Standard: DAS4 (High Precision Assessment)

DASY4 Configuration:

- Probe: ET3DV6 - SN1610; ConvF(5.18, 5.18, 5.18); Calibrated: 11/14/2007
 - Sensor-Surface: 4mm (Mechanical Surface Detection)
 - Electronics: DAE3 Sn448; Calibrated: 15/11/2007
 - Phantom: SAM-1; Type: SAM; Serial: 1437
 - Measurement SW: DAS4, V4.7 Build 53; Postprocessing SW: SEMCAD, V1.8 Build 172
- Touch Position - High/Area Scan (71x131x1):** Measurement grid: dx=10mm, dy=10mm
Maximum value of SAR (interpolated) = 0.380 mW/g
- Touch Position - High/Zoom Scan (5x5x7) (5x5x7)/Cube 0:** Measurement grid:
dx=8mm, dy=8mm, dz=5mm
Reference Value = 2.17 V/m; Power Drift = -0.143 dB
Peak SAR (extrapolated) = 0.543 W/kg
SAR(1 g) = 0.352 mW/g; SAR(10 g) = 0.221 mW/g
Maximum value of SAR (measured) = 0.371 mW/g

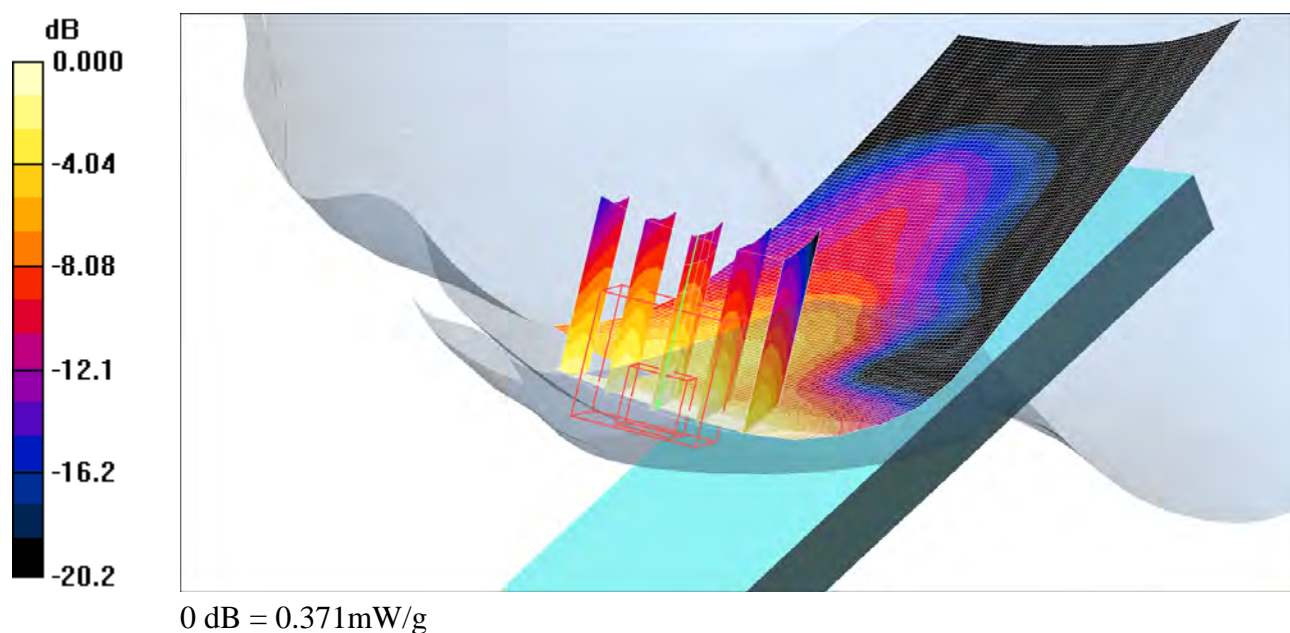

Date/Time: 1/22/2008 4:03:17 PM

Test Laboratory: Sony Ericsson Mobile Communications International AB

Magdalena-RightHandSide-GSM1900-Touch-Low**DUT: Magdalena; Type: DUT; Serial: #10203**

Communication System: DCS 1900; Frequency: 1850.2 MHz; Duty Cycle: 1:8.3

Medium parameters used: $f = 1850.2$ MHz; $\sigma = 1.42$ mho/m; $\epsilon_r = 39.6$; $\rho = 1000$ kg/m³

Phantom section: Right Section

Measurement Standard: DAS4 (High Precision Assessment)

DASY4 Configuration:

- Probe: ET3DV6 - SN1610; ConvF(5.18, 5.18, 5.18); Calibrated: 11/14/2007
 - Sensor-Surface: 4mm (Mechanical Surface Detection)
 - Electronics: DAE3 Sn448; Calibrated: 15/11/2007
 - Phantom: SAM-1; Type: SAM; Serial: 1437
 - Measurement SW: DAS4, V4.7 Build 53; Postprocessing SW: SEMCAD, V1.8 Build 172
- Touch Position- Low/Area Scan (71x131x1):** Measurement grid: dx=10mm, dy=10mm
Maximum value of SAR (interpolated) = 0.365 mW/g
- Touch Position- Low/Zoom Scan (5x5x7) (5x5x7)/Cube 0:** Measurement grid:
dx=8mm, dy=8mm, dz=5mm
Reference Value = 2.56 V/m; Power Drift = 0.144 dB
Peak SAR (extrapolated) = 0.538 W/kg
SAR(1 g) = 0.349 mW/g; SAR(10 g) = 0.217 mW/g
Maximum value of SAR (measured) = 0.369 mW/g

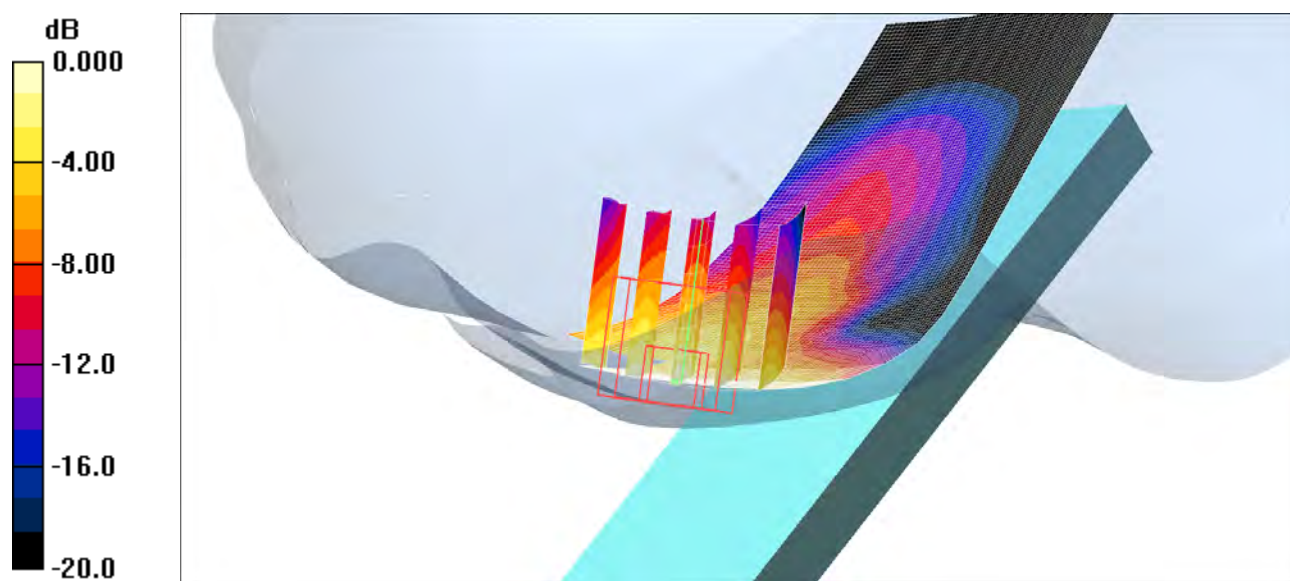

0 dB = 0.369mW/g

Date/Time: 1/22/2008 3:44:55 PM

Test Laboratory: Sony Ericsson Mobile Communications International AB

Magdalena-RightHandSide-GSM1900-Touch-Middle**DUT: Magdalena; Type: DUT; Serial: #10203**

Communication System: DCS 1900; Frequency: 1880 MHz; Duty Cycle: 1:8.3

Medium parameters used: $f = 1880$ MHz; $\sigma = 1.45$ mho/m; $\epsilon_r = 39.5$; $\rho = 1000$ kg/m³

Phantom section: Right Section

Measurement Standard: DAS4 (High Precision Assessment)

DASY4 Configuration:

- Probe: ET3DV6 - SN1610; ConvF(5.18, 5.18, 5.18); Calibrated: 11/14/2007
- Sensor-Surface: 4mm (Mechanical Surface Detection)
- Electronics: DAE3 Sn448; Calibrated: 15/11/2007
- Phantom: SAM-1; Type: SAM; Serial: 1437
- Measurement SW: DAS4, V4.7 Build 53; Postprocessing SW: SEMCAD, V1.8 Build 172

Touch position - Middle/Area Scan (71x131x1): Measurement grid: dx=10mm, dy=10mm

Maximum value of SAR (interpolated) = 0.405 mW/g

Touch position - Middle/Zoom Scan (5x5x7) (5x5x7)/Cube 0: Measurement grid: dx=8mm, dy=8mm, dz=5mm

Reference Value = 2.83 V/m; Power Drift = -0.137 dB

Peak SAR (extrapolated) = 0.587 W/kg

SAR(1 g) = 0.377 mW/g; SAR(10 g) = 0.236 mW/g

Maximum value of SAR (measured) = 0.399 mW/g

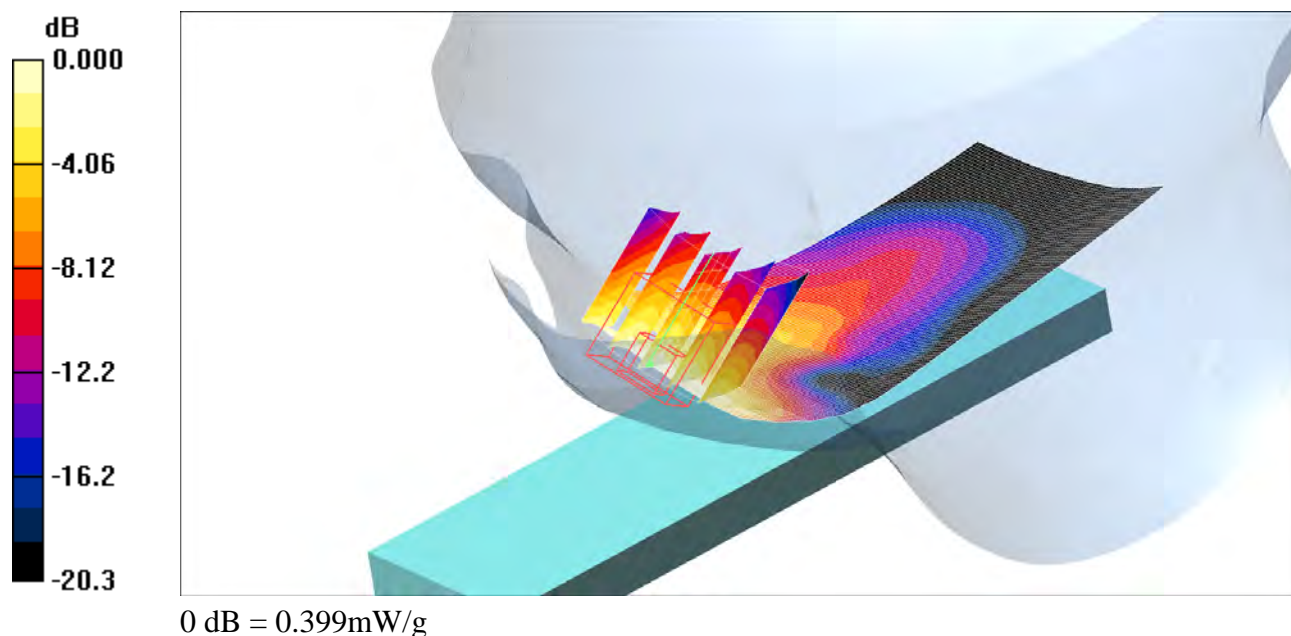

Date/Time: 1/22/2008 2:01:52 PM

Test Laboratory: Sony Ericsson Mobile Communications International AB

Magdalena-LeftHandSide-GSM1900-Tilt-Middle**DUT: Magdalena; Type: DUT; Serial: #10203**

Communication System: DCS 1900; Frequency: 1880 MHz; Duty Cycle: 1:8.3

Medium parameters used: $f = 1880$ MHz; $\sigma = 1.45$ mho/m; $\epsilon_r = 39.5$; $\rho = 1000$ kg/m³

Phantom section: Left Section

Measurement Standard: DAS4 (High Precision Assessment)

DASY4 Configuration:

- Probe: ET3DV6 - SN1610; ConvF(5.18, 5.18, 5.18); Calibrated: 11/14/2007
 - Sensor-Surface: 4mm (Mechanical Surface Detection)
 - Electronics: DAE3 Sn448; Calibrated: 15/11/2007
 - Phantom: SAM-1; Type: SAM; Serial: 1437
 - Measurement SW: DAS4, V4.7 Build 53; Postprocessing SW: SEMCAD, V1.8 Build 172
- Tilt position - Middle/Area Scan (71x131x1):** Measurement grid: dx=10mm, dy=10mm
Maximum value of SAR (interpolated) = 0.065 mW/g
- Tilt position - Middle/Zoom Scan (5x5x7) (5x5x7)/Cube 0:** Measurement grid:
dx=8mm, dy=8mm, dz=5mm
Reference Value = 4.80 V/m; Power Drift = 0.017 dB
Peak SAR (extrapolated) = 0.094 W/kg
SAR(1 g) = 0.059 mW/g; SAR(10 g) = 0.036 mW/g
Maximum value of SAR (measured) = 0.063 mW/g

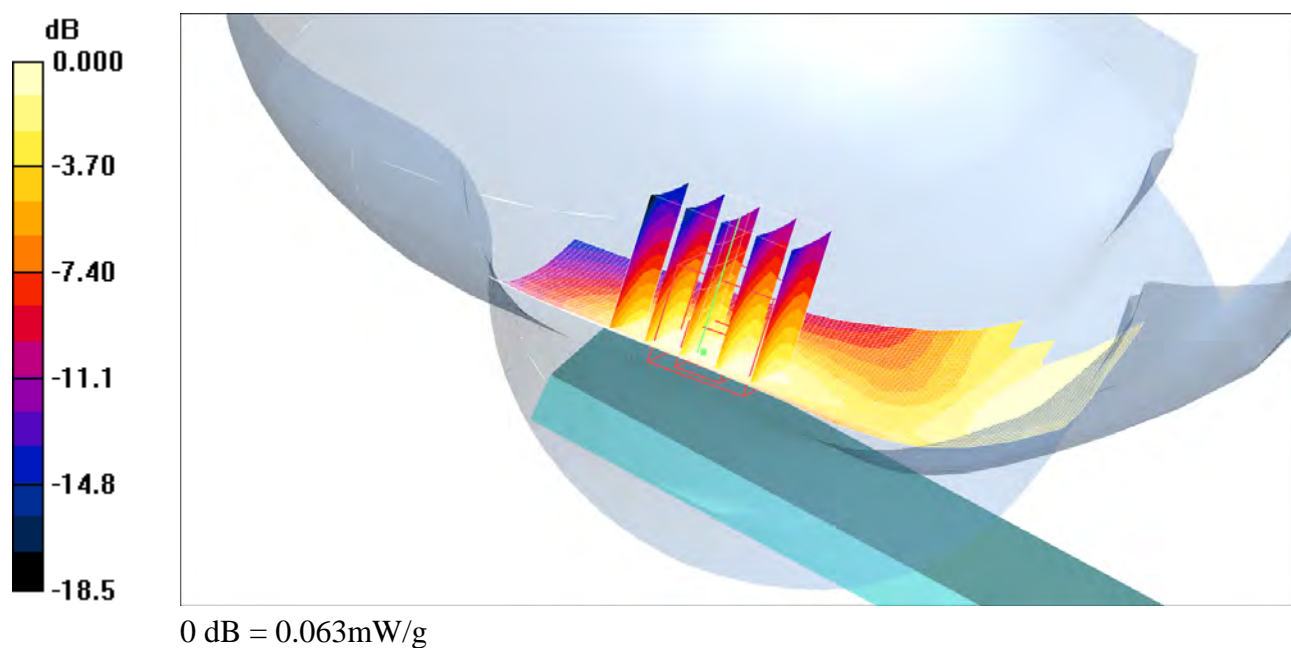

Date/Time: 1/22/2008 2:59:58 PM

Test Laboratory: Sony Ericsson Mobile Communications International AB

Magdalena-LeftHandSide-GSM1900-Touch-High**DUT: Magdalena; Type: DUT; Serial: #10203**

Communication System: DCS 1900; Frequency: 1909.8 MHz; Duty Cycle: 1:8.3

Medium parameters used: $f = 1909.8$ MHz; $\sigma = 1.49$ mho/m; $\epsilon_r = 39.4$; $\rho = 1000$ kg/m³

Phantom section: Left Section

Measurement Standard: DAS4 (High Precision Assessment)

DASY4 Configuration:

- Probe: ET3DV6 - SN1610; ConvF(5.18, 5.18, 5.18); Calibrated: 11/14/2007
- Sensor-Surface: 4mm (Mechanical Surface Detection)
- Electronics: DAE3 Sn448; Calibrated: 15/11/2007
- Phantom: SAM-1; Type: SAM; Serial: 1437
- Measurement SW: DAS4, V4.7 Build 53; Postprocessing SW: SEMCAD, V1.8 Build 172

Touch - High/Area Scan (71x131x1): Measurement grid: dx=10mm, dy=10mm

Maximum value of SAR (interpolated) = 0.300 mW/g

Touch - High/Zoom Scan (5x5x7) (5x5x7)/Cube 0: Measurement grid: dx=8mm, dy=8mm, dz=5mm

Reference Value = 2.15 V/m; Power Drift = 0.141 dB

Peak SAR (extrapolated) = 0.506 W/kg

SAR(1 g) = 0.272 mW/g; SAR(10 g) = 0.155 mW/g

Maximum value of SAR (measured) = 0.312 mW/g

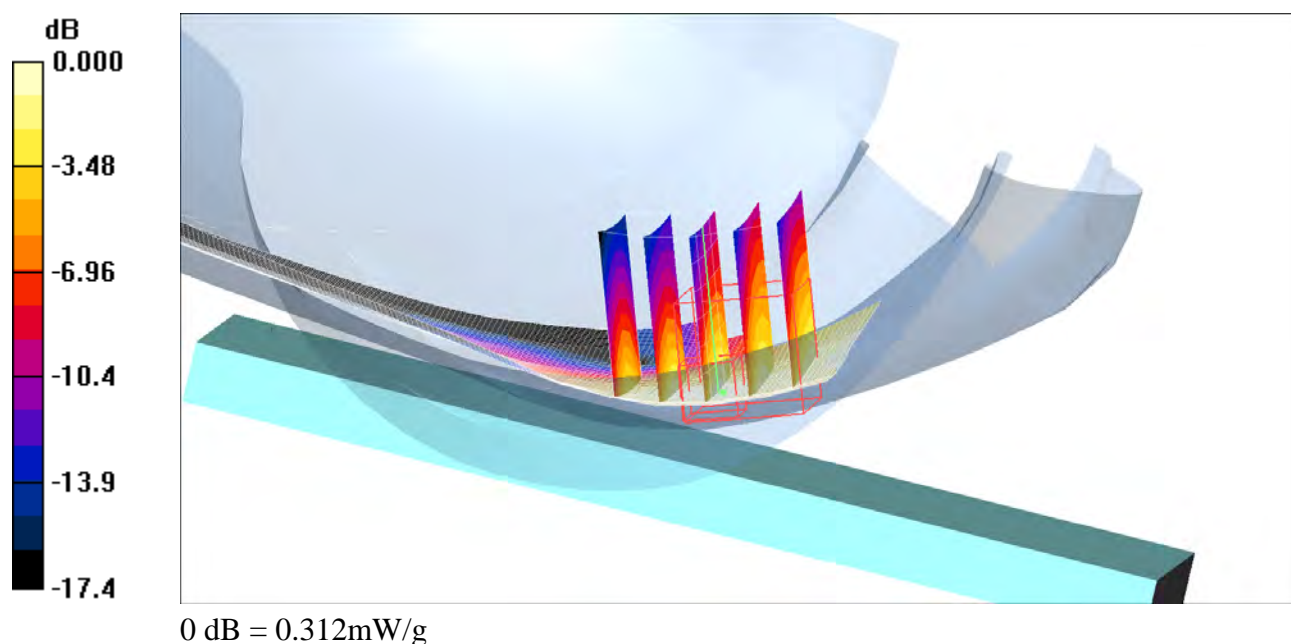

Date/Time: 1/22/2008 2:40:26 PM

Test Laboratory: Sony Ericsson Mobile Communications International AB

Magdalena-LeftHandSide-GSM1900-Touch-Low**DUT: Magdalena; Type: DUT; Serial: #10203**

Communication System: DCS 1900; Frequency: 1850.2 MHz; Duty Cycle: 1:8.3

Medium parameters used: $f = 1850.2$ MHz; $\sigma = 1.42$ mho/m; $\epsilon_r = 39.6$; $\rho = 1000$ kg/m³

Phantom section: Left Section

Measurement Standard: DAS4 (High Precision Assessment)

DASY4 Configuration:

- Probe: ET3DV6 - SN1610; ConvF(5.18, 5.18, 5.18); Calibrated: 11/14/2007
- Sensor-Surface: 4mm (Mechanical Surface Detection)
- Electronics: DAE3 Sn448; Calibrated: 15/11/2007
- Phantom: SAM-1; Type: SAM; Serial: 1437
- Measurement SW: DAS4, V4.7 Build 53; Postprocessing SW: SEMCAD, V1.8 Build 172

Touch - Low/Area Scan (71x131x1): Measurement grid: dx=10mm, dy=10mm

Maximum value of SAR (interpolated) = 0.266 mW/g

Touch - Low/Zoom Scan (5x5x7) (5x5x7)/Cube 0: Measurement grid: dx=8mm, dy=8mm, dz=5mm

Reference Value = 2.33 V/m; Power Drift = -0.052 dB

Peak SAR (extrapolated) = 0.435 W/kg

SAR(1 g) = 0.241 mW/g; SAR(10 g) = 0.141 mW/g

Maximum value of SAR (measured) = 0.277 mW/g

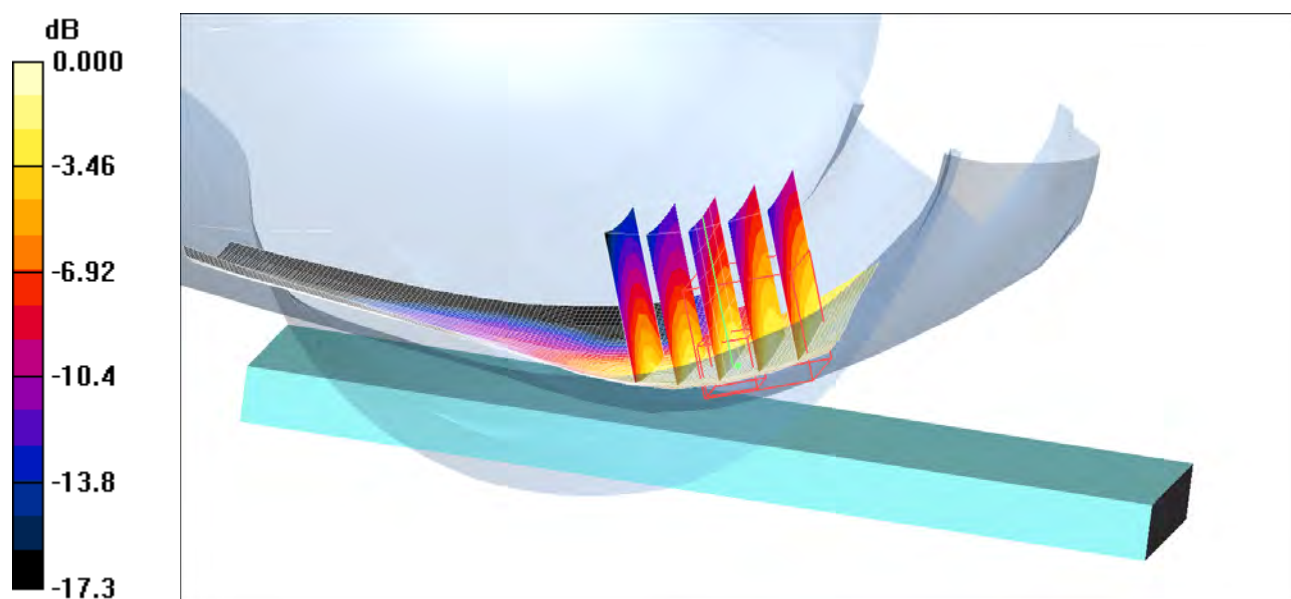

Date/Time: 1/22/2008 1:25:59 PM

Test Laboratory: Sony Ericsson Mobile Communications International AB

Magdalena-LeftHandSide-GSM1900-Touch-Middle**DUT: Magdalena; Type: DUT; Serial: #10203**

Communication System: DCS 1900; Frequency: 1880 MHz; Duty Cycle: 1:8.3

Medium parameters used: $f = 1880$ MHz; $\sigma = 1.45$ mho/m; $\epsilon_r = 39.5$; $\rho = 1000$ kg/m³

Phantom section: Left Section

Measurement Standard: DAS4 (High Precision Assessment)

DASY4 Configuration:

- Probe: ET3DV6 - SN1610; ConvF(5.18, 5.18, 5.18); Calibrated: 11/14/2007
- Sensor-Surface: 4mm (Mechanical Surface Detection)
- Electronics: DAE3 Sn448; Calibrated: 15/11/2007
- Phantom: SAM-1; Type: SAM; Serial: 1437
- Measurement SW: DAS4, V4.7 Build 53; Postprocessing SW: SEMCAD, V1.8 Build 172

Touch position - Middle/Area Scan (71x131x1): Measurement grid: dx=10mm, dy=10mm

Maximum value of SAR (interpolated) = 0.321 mW/g

Touch position - Middle/Zoom Scan (5x5x7) (5x5x7)/Cube 0: Measurement grid: dx=8mm, dy=8mm, dz=5mm

Reference Value = 2.74 V/m; Power Drift = -0.009 dB

Peak SAR (extrapolated) = 0.533 W/kg

SAR(1 g) = 0.289 mW/g; SAR(10 g) = 0.166 mW/g

Maximum value of SAR (measured) = 0.333 mW/g

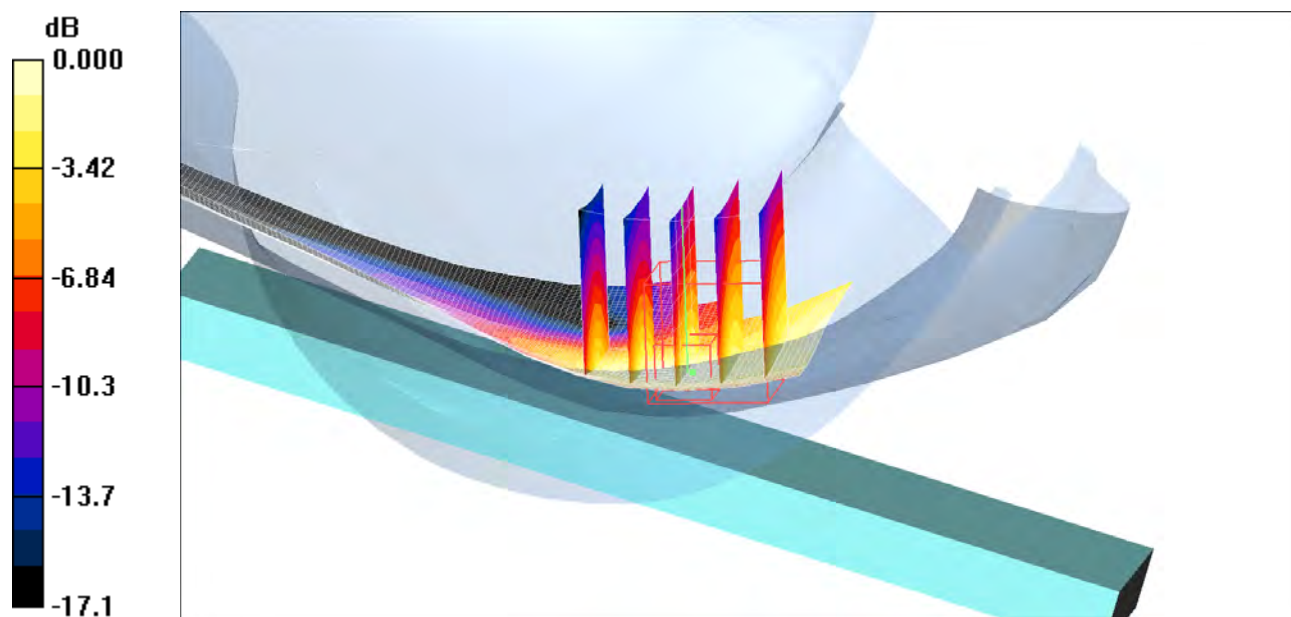

0 dB = 0.333mW/g

Date/Time: 1/29/2008 4:51:36 PM

Test Laboratory: Sony Ericsson Mobile Communications International AB

Body-Flat15mm-Magdalena-1900Bluetooth-High**DUT: Magdalena; Type: DUT; Serial: #10203**

Communication System: DCS 1900; Frequency: 1909.8 MHz; Duty Cycle: 1:8.3

Medium parameters used: $f = 1909.8$ MHz; $\sigma = 1.61$ mho/m; $\epsilon_r = 51$; $\rho = 1000$ kg/m³

Phantom section: Flat Section

Measurement Standard: DAS4 (High Precision Assessment)

DASY4 Configuration:

- Probe: ET3DV6 - SN1610; ConvF(4.68, 4.68, 4.68); Calibrated: 11/14/2007
- Sensor-Surface: 4mm (Mechanical Surface Detection)
- Electronics: DAE3 Sn448; Calibrated: 15/11/2007
- Phantom: SAM-3; Type: SAM; Serial: 1436
- Measurement SW: DAS4, V4.7 Build 53; Postprocessing SW: SEMCAD, V1.8 Build 172

Body 3/Area Scan (41x71x1): Measurement grid: dx=15mm, dy=15mm

Maximum value of SAR (interpolated) = 0.373 mW/g

Body 3/Zoom Scan (7x5x5)/Cube 0: Measurement grid: dx=5mm, dy=8mm, dz=8mm

Reference Value = 13.7 V/m; Power Drift = -0.022 dB

Peak SAR (extrapolated) = 0.563 W/kg

SAR(1 g) = 0.346 mW/g; SAR(10 g) = 0.209 mW/g

Maximum value of SAR (measured) = 0.370 mW/g

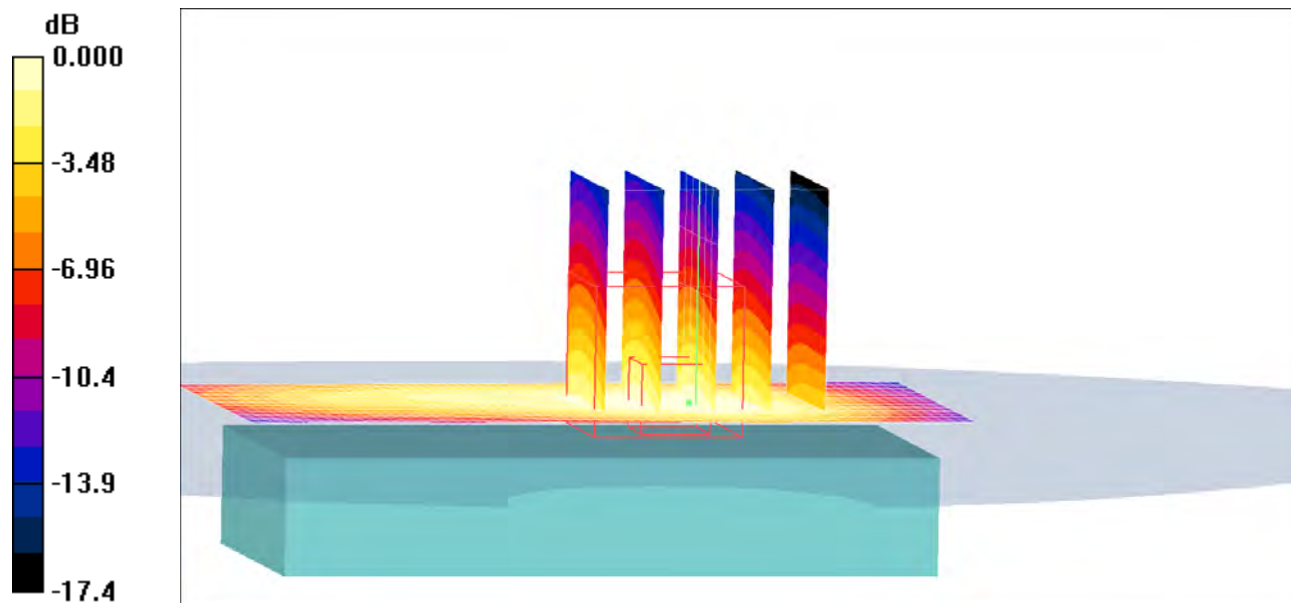

0 dB = 0.370mW/g

Date/Time: 1/29/2008 4:26:49 PM

Test Laboratory: Sony Ericsson Mobile Communications International AB

Body-Flat15mm-Magdalena-1900Bluetooth-Low**DUT: Magdalena; Type: DUT; Serial: #10203**

Communication System: DCS 1900; Frequency: 1850.2 MHz; Duty Cycle: 1:8.3

Medium parameters used: $f = 1850.2$ MHz; $\sigma = 1.54$ mho/m; $\epsilon_r = 51.1$; $\rho = 1000$ kg/m³

Phantom section: Flat Section

Measurement Standard: DAS4 (High Precision Assessment)

DASY4 Configuration:

- Probe: ET3DV6 - SN1610; ConvF(4.68, 4.68, 4.68); Calibrated: 11/14/2007
- Sensor-Surface: 4mm (Mechanical Surface Detection)
- Electronics: DAE3 Sn448; Calibrated: 15/11/2007
- Phantom: SAM-3; Type: SAM; Serial: 1436
- Measurement SW: DAS4, V4.7 Build 53; Postprocessing SW: SEMCAD, V1.8 Build 172

Body/Area Scan (41x71x1): Measurement grid: dx=15mm, dy=15mm

Maximum value of SAR (interpolated) = 0.494 mW/g

Body/Zoom Scan (7x5x5)/Cube 0: Measurement grid: dx=5mm, dy=8mm, dz=8mm

Reference Value = 16.0 V/m; Power Drift = -0.005 dB

Peak SAR (extrapolated) = 0.729 W/kg

SAR(1 g) = 0.462 mW/g; SAR(10 g) = 0.283 mW/g

Maximum value of SAR (measured) = 0.497 mW/g

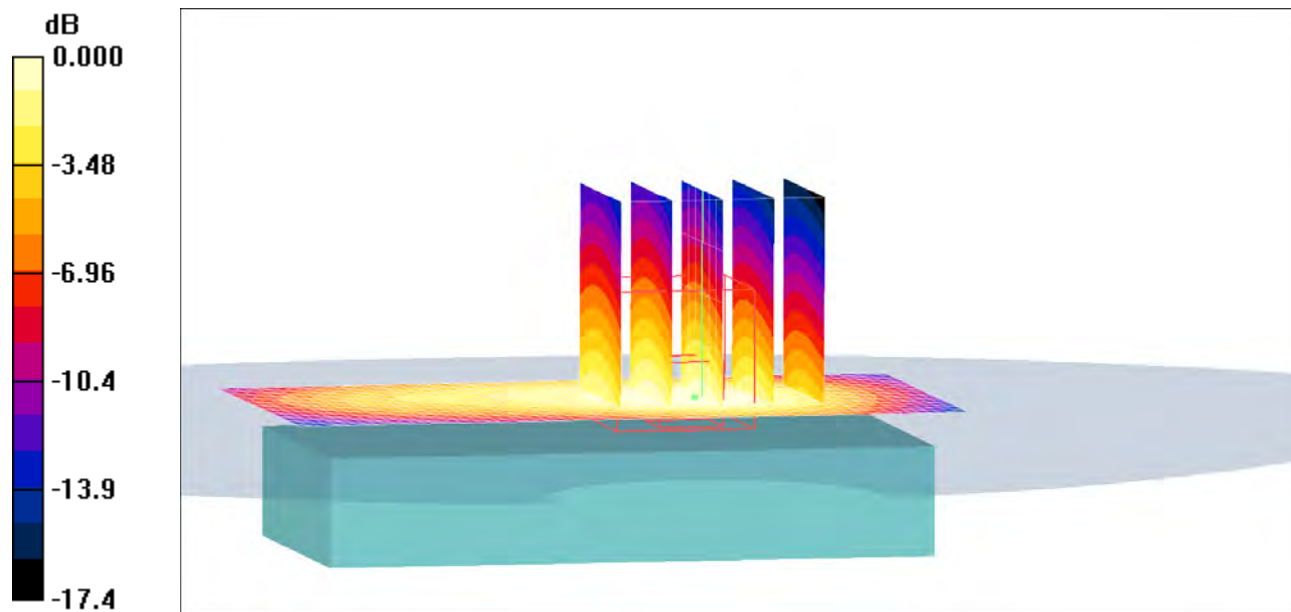

0 dB = 0.497mW/g

Date/Time: 1/29/2008 4:39:48 PM

Test Laboratory: Sony Ericsson Mobile Communications International AB

Body-Flat15mm-Magdalena-1900Bluetooth-Middle**DUT: Magdalena; Type: DUT; Serial: #10203**

Communication System: DCS 1900; Frequency: 1880 MHz; Duty Cycle: 1:8.3

Medium parameters used: $f = 1880$ MHz; $\sigma = 1.57$ mho/m; $\epsilon_r = 51$; $\rho = 1000$ kg/m³

Phantom section: Flat Section

Measurement Standard: DAS4 (High Precision Assessment)

DASY4 Configuration:

- Probe: ET3DV6 - SN1610; ConvF(4.68, 4.68, 4.68); Calibrated: 11/14/2007
- Sensor-Surface: 4mm (Mechanical Surface Detection)
- Electronics: DAE3 Sn448; Calibrated: 15/11/2007
- Phantom: SAM-3; Type: SAM; Serial: 1436
- Measurement SW: DAS4, V4.7 Build 53; Postprocessing SW: SEMCAD, V1.8 Build 172

Body 2/Area Scan (41x71x1): Measurement grid: dx=15mm, dy=15mm

Maximum value of SAR (interpolated) = 0.452 mW/g

Body 2/Zoom Scan (7x5x5)/Cube 0: Measurement grid: dx=5mm, dy=8mm, dz=8mm

Reference Value = 15.3 V/m; Power Drift = 0.004 dB

Peak SAR (extrapolated) = 0.665 W/kg

SAR(1 g) = 0.418 mW/g; SAR(10 g) = 0.255 mW/g

Maximum value of SAR (measured) = 0.443 mW/g

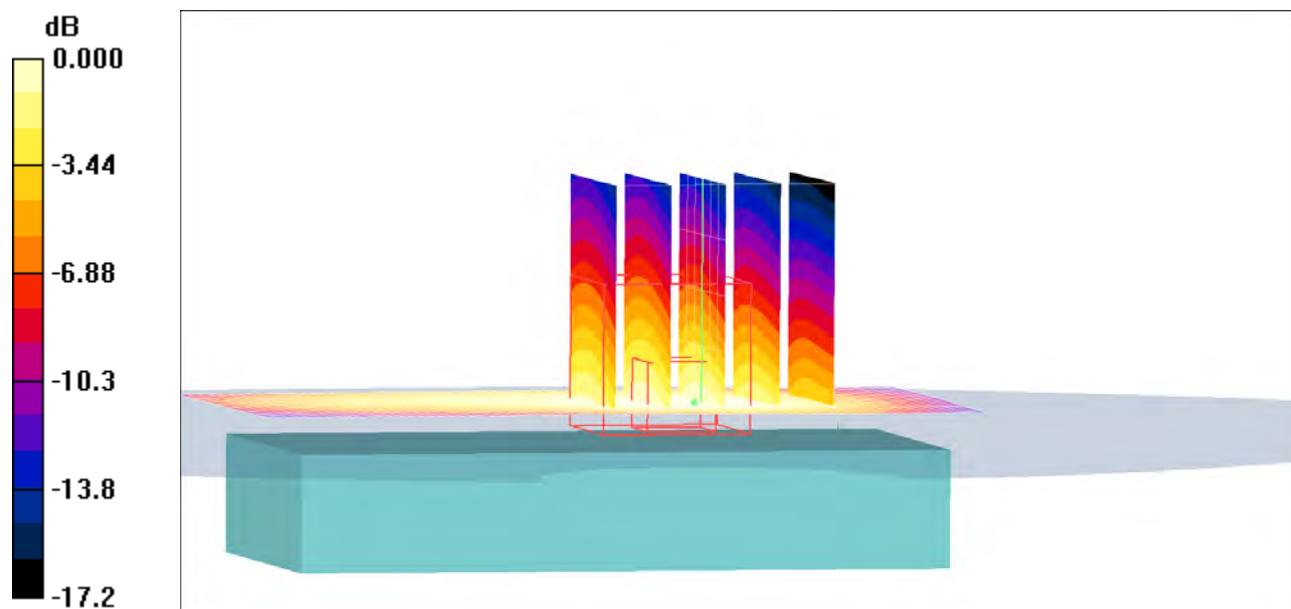

0 dB = 0.443mW/g

Date/Time: 1/29/2008 4:04:41 PM

Test Laboratory: Sony Ericsson Mobile Communications International AB

Body-Flat15mm-Magdalena-1900EDGE-Low**DUT: Magdalena; Type: DUT; Serial: #10203**

Communication System: GPRS 1900; Frequency: 1850.2 MHz; Duty Cycle: 1:4.15

Medium parameters used: $f = 1850.2$ MHz; $\sigma = 1.54$ mho/m; $\epsilon_r = 51.1$; $\rho = 1000$ kg/m³

Phantom section: Flat Section

Measurement Standard: DAS4 (High Precision Assessment)

DASY4 Configuration:

- Probe: ET3DV6 - SN1610; ConvF(4.68, 4.68, 4.68); Calibrated: 11/14/2007
- Sensor-Surface: 4mm (Mechanical Surface Detection)
- Electronics: DAE3 Sn448; Calibrated: 15/11/2007
- Phantom: SAM-3; Type: SAM; Serial: 1436
- Measurement SW: DAS4, V4.7 Build 53; Postprocessing SW: SEMCAD, V1.8 Build 172

Body/Area Scan (41x71x1): Measurement grid: dx=15mm, dy=15mm

Maximum value of SAR (interpolated) = 0.316 mW/g

Body/Zoom Scan (7x5x5)/Cube 0: Measurement grid: dx=5mm, dy=8mm, dz=8mm

Reference Value = 12.7 V/m; Power Drift = 0.014 dB

Peak SAR (extrapolated) = 0.504 W/kg

SAR(1 g) = 0.304 mW/g; SAR(10 g) = 0.187 mW/g

Maximum value of SAR (measured) = 0.327 mW/g

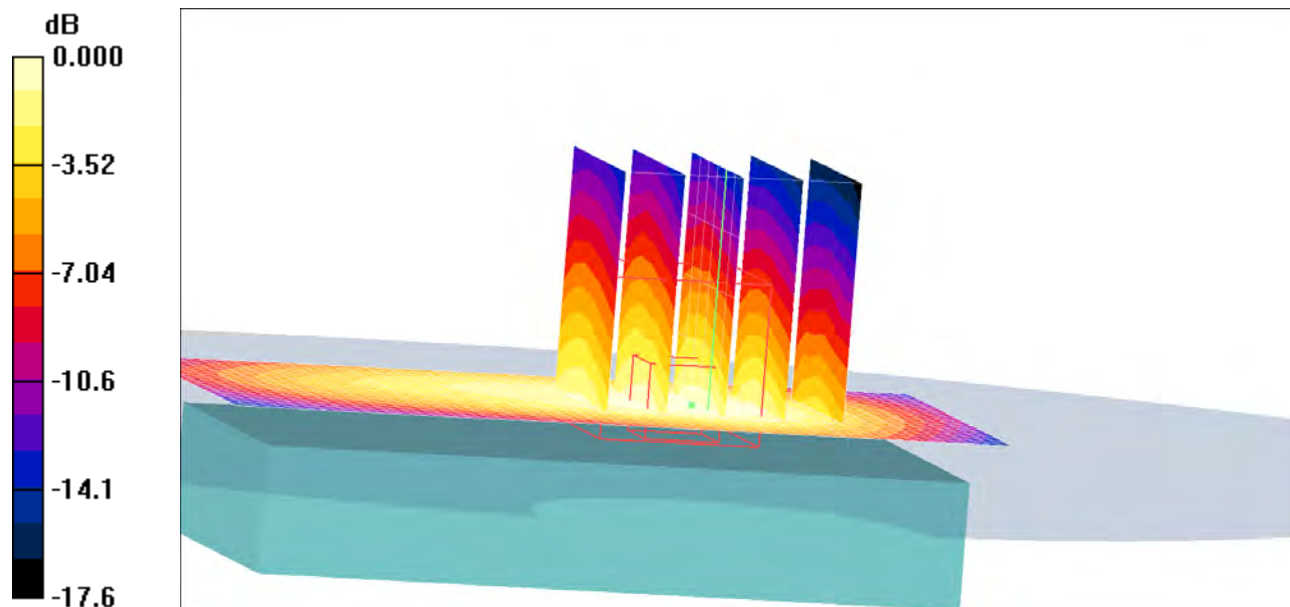

0 dB = 0.327mW/g

Date/Time: 1/29/2008 5:25:40 PM

Test Laboratory: Sony Ericsson Mobile Communications International AB

Body-Flat15mm-Magdalena-1900-Front-To-Phantom-Low**DUT: Magdalena; Type: DUT; Serial: #10203**

Communication System: GPRS 1900; Frequency: 1850.2 MHz; Duty Cycle: 1:4.15

Medium parameters used: $f = 1850.2$ MHz; $\sigma = 1.54$ mho/m; $\epsilon_r = 51.1$; $\rho = 1000$ kg/m³

Phantom section: Flat Section

Measurement Standard: DAS4 (High Precision Assessment)

DASY4 Configuration:

- Probe: ET3DV6 - SN1610; ConvF(4.68, 4.68, 4.68); Calibrated: 11/14/2007
- Sensor-Surface: 4mm (Mechanical Surface Detection)
- Electronics: DAE3 Sn448; Calibrated: 15/11/2007
- Phantom: SAM-3; Type: SAM; Serial: 1436
- Measurement SW: DAS4, V4.7 Build 53; Postprocessing SW: SEMCAD, V1.8 Build 172

Body/Area Scan (41x71x1): Measurement grid: dx=15mm, dy=15mm

Maximum value of SAR (interpolated) = 0.288 mW/g

Body/Zoom Scan (7x5x5)/Cube 0: Measurement grid: dx=5mm, dy=8mm, dz=8mm

Reference Value = 9.00 V/m; Power Drift = -0.042 dB

Peak SAR (extrapolated) = 0.400 W/kg

SAR(1 g) = 0.262 mW/g; SAR(10 g) = 0.165 mW/g

Maximum value of SAR (measured) = 0.282 mW/g

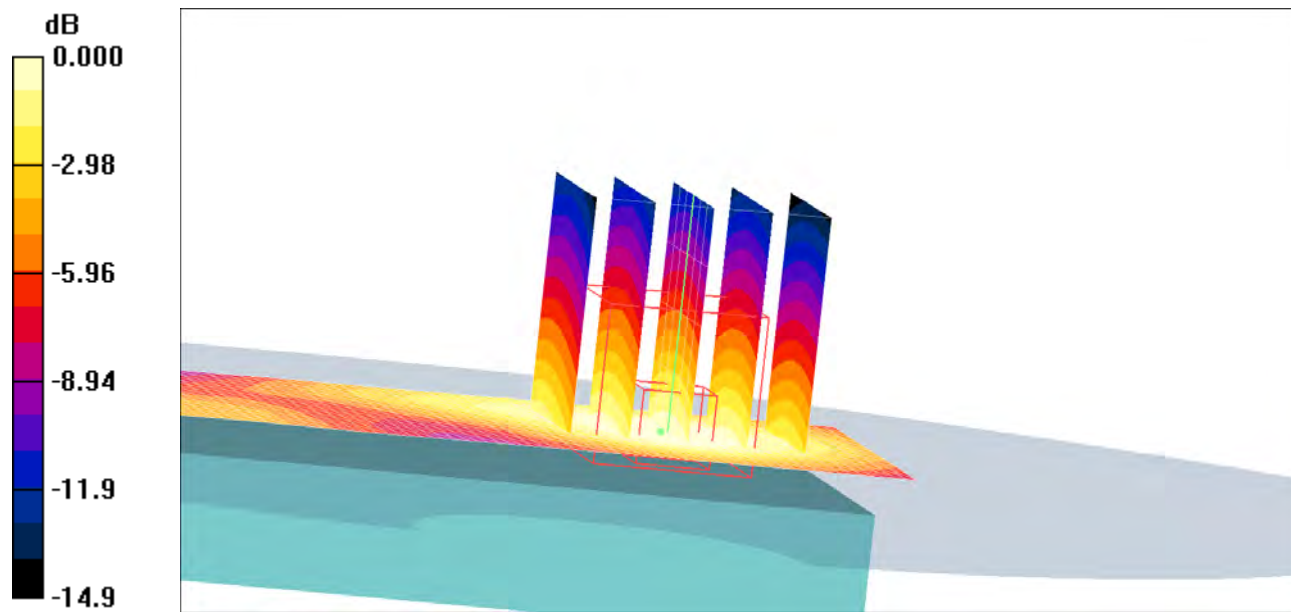

0 dB = 0.282mW/g

Date/Time: 1/29/2008 3:39:08 PM

Test Laboratory: Sony Ericsson Mobile Communications International AB

Body-Flat15mm-Magdalena-1900GPRS-High**DUT: Magdalena; Type: DUT; Serial: #10203**

Communication System: GPRS 1900; Frequency: 1909.8 MHz; Duty Cycle: 1:4.15

Medium parameters used: $f = 1909.8$ MHz; $\sigma = 1.61$ mho/m; $\epsilon_r = 51$; $\rho = 1000$ kg/m³

Phantom section: Flat Section

Measurement Standard: DAS4 (High Precision Assessment)

DASY4 Configuration:

- Probe: ET3DV6 - SN1610; ConvF(4.68, 4.68, 4.68); Calibrated: 11/14/2007
- Sensor-Surface: 4mm (Mechanical Surface Detection)
- Electronics: DAE3 Sn448; Calibrated: 15/11/2007
- Phantom: SAM-3; Type: SAM; Serial: 1436
- Measurement SW: DAS4, V4.7 Build 53; Postprocessing SW: SEMCAD, V1.8 Build 172

Body 3/Area Scan (41x71x1): Measurement grid: dx=15mm, dy=15mm

Maximum value of SAR (interpolated) = 0.710 mW/g

Body 3/Zoom Scan (7x5x5)/Cube 0: Measurement grid: dx=5mm, dy=8mm, dz=8mm

Reference Value = 19.3 V/m; Power Drift = -0.052 dB

Peak SAR (extrapolated) = 1.07 W/kg

SAR(1 g) = 0.660 mW/g; SAR(10 g) = 0.401 mW/g

Maximum value of SAR (measured) = 0.703 mW/g

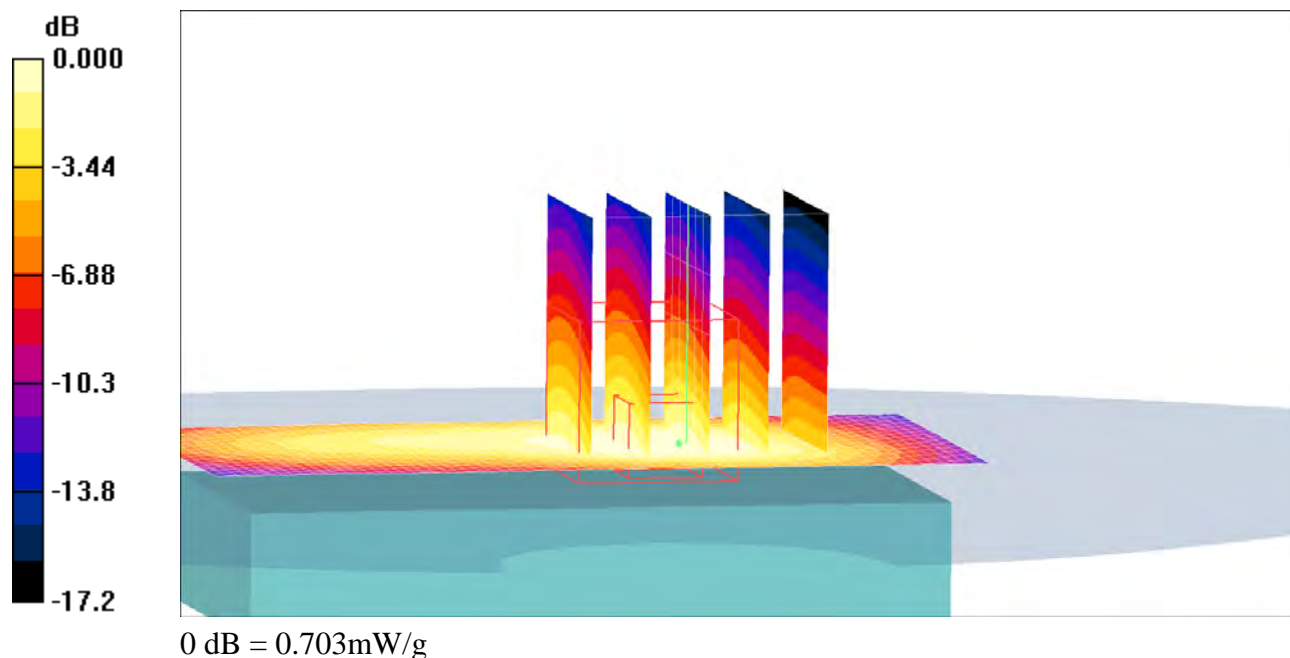

Date/Time: 1/29/2008 3:04:27 PM

Test Laboratory: Sony Ericsson Mobile Communications International AB

Body-Flat15mm-Magdalena-1900GPRS-Low**DUT: Magdalena; Type: DUT; Serial: #10203**

Communication System: GPRS 1900; Frequency: 1850.2 MHz; Duty Cycle: 1:4.15

Medium parameters used: $f = 1850.2$ MHz; $\sigma = 1.54$ mho/m; $\epsilon_r = 51.1$; $\rho = 1000$ kg/m³

Phantom section: Flat Section

Measurement Standard: DAS4 (High Precision Assessment)

DASY4 Configuration:

- Probe: ET3DV6 - SN1610; ConvF(4.68, 4.68, 4.68); Calibrated: 11/14/2007
- Sensor-Surface: 4mm (Mechanical Surface Detection)
- Electronics: DAE3 Sn448; Calibrated: 15/11/2007
- Phantom: SAM-3; Type: SAM; Serial: 1436
- Measurement SW: DAS4, V4.7 Build 53; Postprocessing SW: SEMCAD, V1.8 Build 172

Body/Area Scan (41x71x1): Measurement grid: dx=15mm, dy=15mm

Maximum value of SAR (interpolated) = 0.973 mW/g

Body/Zoom Scan (7x5x5)/Cube 0: Measurement grid: dx=5mm, dy=8mm, dz=8mm

Reference Value = 22.5 V/m; Power Drift = -0.085 dB

Peak SAR (extrapolated) = 1.37 W/kg

SAR(1 g) = 0.883 mW/g; SAR(10 g) = 0.546 mW/g

Maximum value of SAR (measured) = 0.952 mW/g

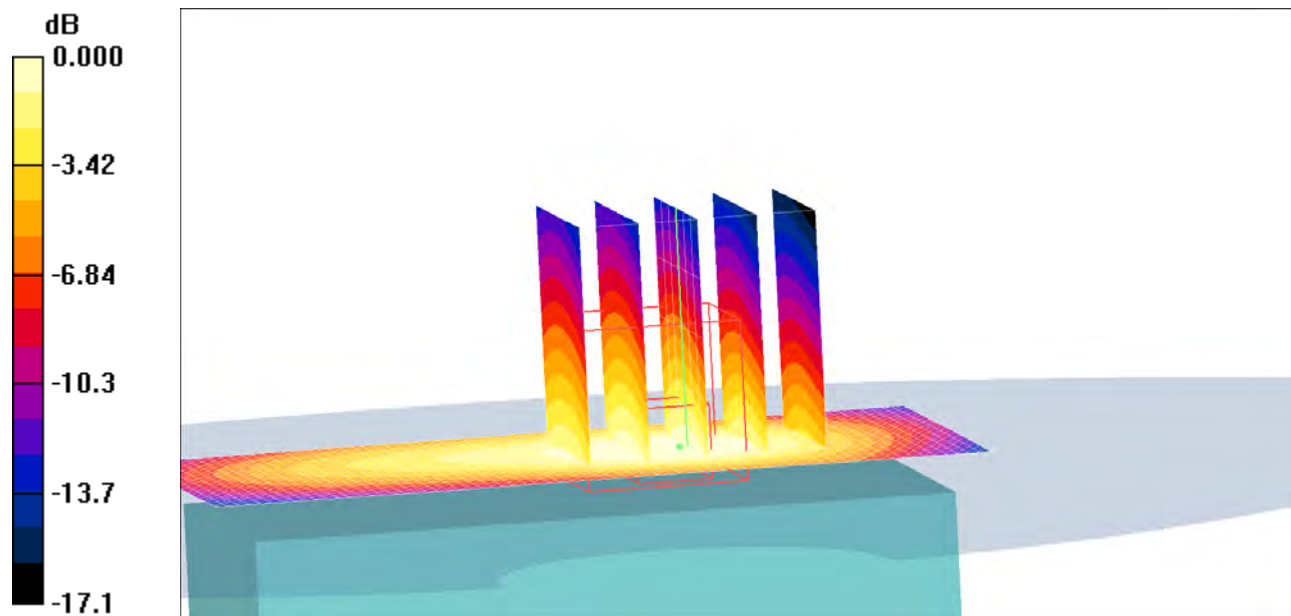

0 dB = 0.952mW/g

Date/Time: 1/29/2008 3:21:22 PM

Test Laboratory: Sony Ericsson Mobile Communications International AB

Body-Flat15mm-Magdalena-1900GPRS-Middle**DUT: Magdalena; Type: DUT; Serial: #10203**

Communication System: GPRS 1900; Frequency: 1880 MHz; Duty Cycle: 1:4.15

Medium parameters used: $f = 1880$ MHz; $\sigma = 1.57$ mho/m; $\epsilon_r = 51$; $\rho = 1000$ kg/m³

Phantom section: Flat Section

Measurement Standard: DAS4 (High Precision Assessment)

DASY4 Configuration:

- Probe: ET3DV6 - SN1610; ConvF(4.68, 4.68, 4.68); Calibrated: 11/14/2007
- Sensor-Surface: 4mm (Mechanical Surface Detection)
- Electronics: DAE3 Sn448; Calibrated: 15/11/2007
- Phantom: SAM-3; Type: SAM; Serial: 1436
- Measurement SW: DAS4, V4.7 Build 53; Postprocessing SW: SEMCAD, V1.8 Build 172

Body 2/Area Scan (41x71x1): Measurement grid: dx=15mm, dy=15mm

Maximum value of SAR (interpolated) = 0.880 mW/g

Body 2/Zoom Scan (7x5x5)/Cube 0: Measurement grid: dx=5mm, dy=8mm, dz=8mm

Reference Value = 21.6 V/m; Power Drift = -0.134 dB

Peak SAR (extrapolated) = 1.28 W/kg

SAR(1 g) = 0.802 mW/g; SAR(10 g) = 0.491 mW/g

Maximum value of SAR (measured) = 0.861 mW/g

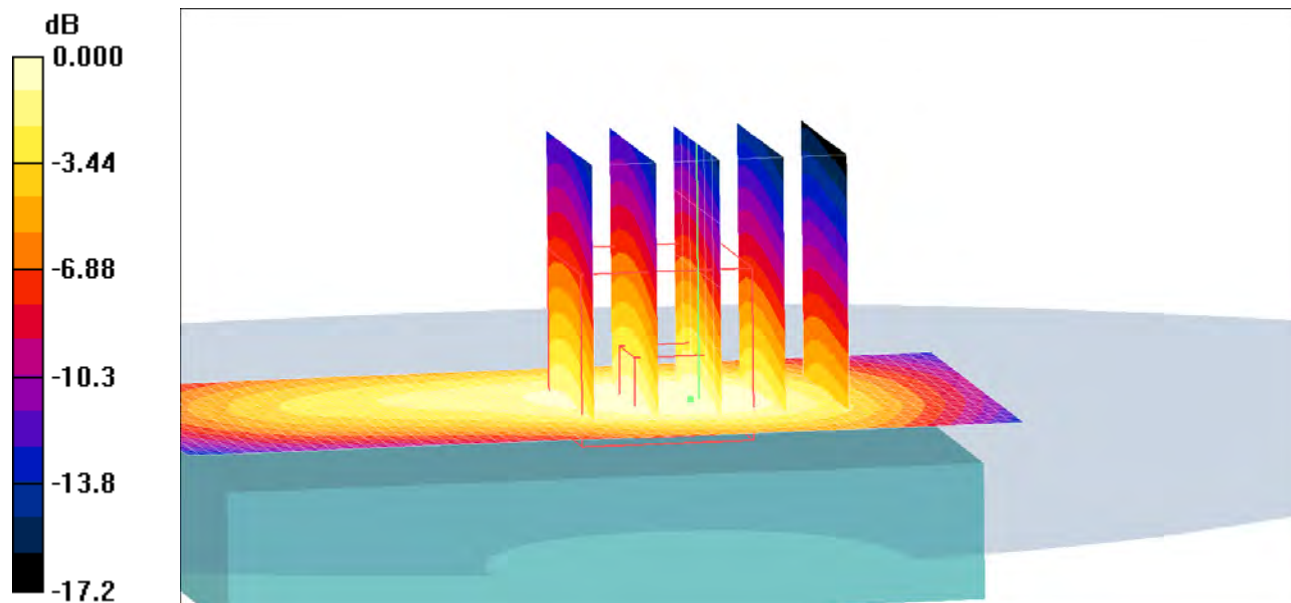

0 dB = 0.861mW/g

Date/Time: 1/29/2008 5:11:00 PM

Test Laboratory: Sony Ericsson Mobile Communications International AB

Body-Flat15mm-Magdalena-1900PHF-Low**DUT: Magdalena; Type: DUT; Serial: #10203**

Communication System: DCS 1900; Frequency: 1850.2 MHz; Duty Cycle: 1:8.3

Medium parameters used: $f = 1850.2$ MHz; $\sigma = 1.54$ mho/m; $\epsilon_r = 51.1$; $\rho = 1000$ kg/m³

Phantom section: Flat Section

Measurement Standard: DAS4 (High Precision Assessment)

DASY4 Configuration:

- Probe: ET3DV6 - SN1610; ConvF(4.68, 4.68, 4.68); Calibrated: 11/14/2007
- Sensor-Surface: 4mm (Mechanical Surface Detection)
- Electronics: DAE3 Sn448; Calibrated: 15/11/2007
- Phantom: SAM-3; Type: SAM; Serial: 1436
- Measurement SW: DAS4, V4.7 Build 53; Postprocessing SW: SEMCAD, V1.8 Build 172

Body/Area Scan (41x71x1): Measurement grid: dx=15mm, dy=15mm

Maximum value of SAR (interpolated) = 0.600 mW/g

Body/Zoom Scan (7x5x5)/Cube 0: Measurement grid: dx=5mm, dy=8mm, dz=8mm

Reference Value = 15.4 V/m; Power Drift = -0.039 dB

Peak SAR (extrapolated) = 0.867 W/kg

SAR(1 g) = 0.540 mW/g; SAR(10 g) = 0.323 mW/g

Maximum value of SAR (measured) = 0.576 mW/g

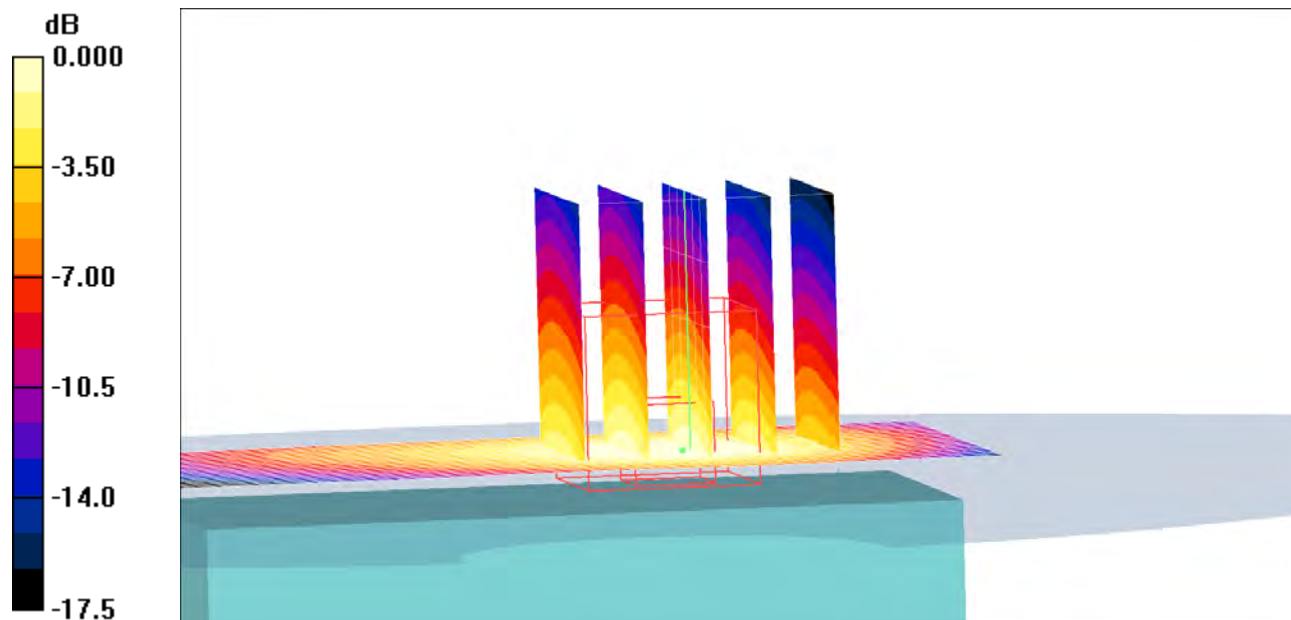

0 dB = 0.576mW/g

Date/Time: 1/16/2008 11:47:42 AM

Test Laboratory: Sony Ericsson Mobile Communications International AB

SystemPerformanceCheck-D850-16-01-08**DUT: Dipole 835 MHz; Type: D835V2; Serial: D835V2 - SN:442**

Communication System: CW; Frequency: 835 MHz; Duty Cycle: 1:1

Medium parameters used: $f = 835 \text{ MHz}$; $\sigma = 0.86 \text{ mho/m}$; $\epsilon_r = 39.7$; $\rho = 1000 \text{ kg/m}^3$

Phantom section: Flat Section

Measurement Standard: DAS4 (High Precision Assessment)

DASY4 Configuration:

- Probe: ET3DV6 - SN1610; ConvF(6.69, 6.69, 6.69); Calibrated: 11/14/2007
 - Sensor-Surface: 4mm (Mechanical Surface Detection)
 - Electronics: DAE3 Sn448; Calibrated: 15/11/2007
 - Phantom: SAM-2; Type: SAM; Serial: 1025
 - Measurement SW: DAS4, V4.7 Build 53; Postprocessing SW: SEMCAD, V1.8 Build 172
- d=15mm, Pin=250mW/Area Scan (61x81x1):** Measurement grid: dx=15mm, dy=15mm
Maximum value of SAR (interpolated) = 2.47 mW/g
- d=15mm, Pin=250mW/Zoom Scan (7x7x7) (5x5x7)/Cube 0:** Measurement grid:
dx=8mm, dy=8mm, dz=5mm
Reference Value = 55.9 V/m; Power Drift = 0.034 dB
Peak SAR (extrapolated) = 3.22 W/kg
SAR(1 g) = 2.3 mW/g; SAR(10 g) = 1.53 mW/g
Maximum value of SAR (measured) = 2.49 mW/g

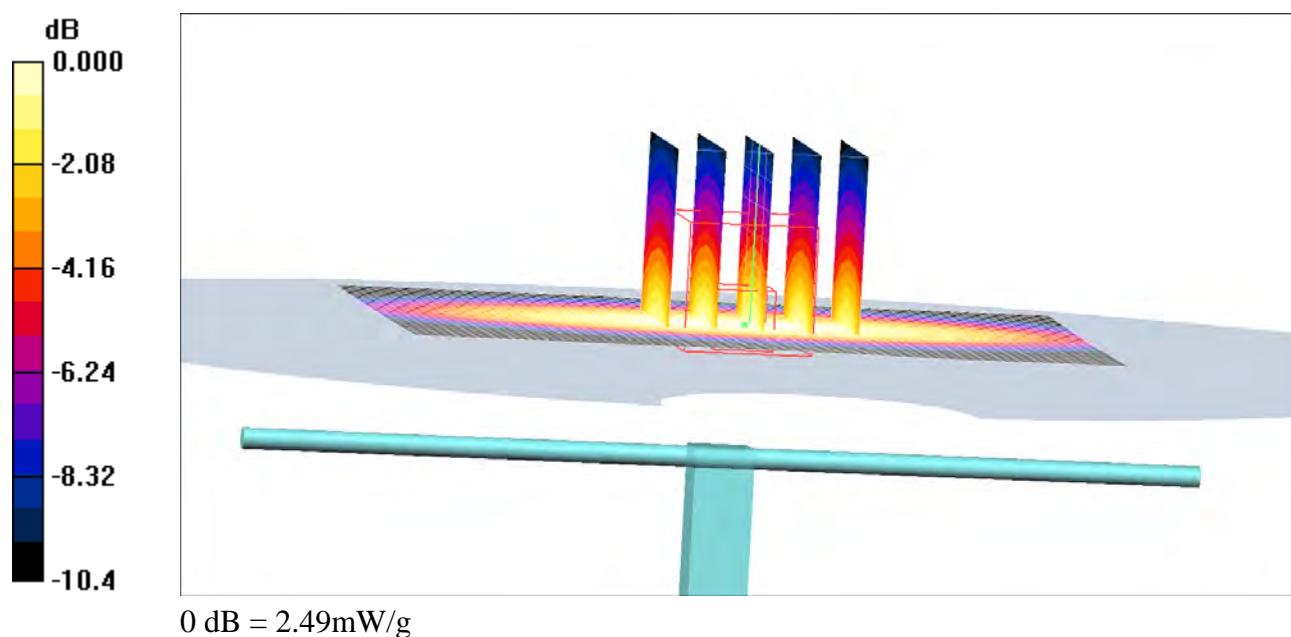

Date/Time: 1/21/2008 9:50:49 AM

Test Laboratory: Sony Ericsson Mobile Communications International AB

SystemPerformanceCheck-D850-21-01-08-Body**DUT: Dipole 835 MHz; Type: D835V2; Serial: D835V2 - SN:442**

Communication System: CW; Frequency: 835 MHz; Duty Cycle: 1:1

Medium parameters used: $f = 835$ MHz; $\sigma = 0.98$ mho/m; $\epsilon_r = 55.1$; $\rho = 1000$ kg/m³

Phantom section: Flat Section

Measurement Standard: DAS4 (High Precision Assessment)

DASY4 Configuration:

- Probe: ET3DV6 - SN1610; ConvF(6.39, 6.39, 6.39); Calibrated: 11/14/2007
 - Sensor-Surface: 4mm (Mechanical Surface Detection)
 - Electronics: DAE3 Sn448; Calibrated: 15/11/2007
 - Phantom: SAM-3; Type: SAM; Serial: 1436
 - Measurement SW: DAS4, V4.7 Build 53; Postprocessing SW: SEMCAD, V1.8 Build 172
- d=15mm, Pin=250mW/Area Scan (61x81x1):** Measurement grid: dx=15mm, dy=15mm
Maximum value of SAR (interpolated) = 2.56 mW/g
- d=15mm, Pin=250mW/Zoom Scan (7x7x7) (5x5x7)/Cube 0:** Measurement grid:
dx=8mm, dy=8mm, dz=5mm
Reference Value = 53.7 V/m; Power Drift = 0.017 dB
Peak SAR (extrapolated) = 3.24 W/kg
SAR(1 g) = 2.37 mW/g; SAR(10 g) = 1.57 mW/g
Maximum value of SAR (measured) = 2.57 mW/g

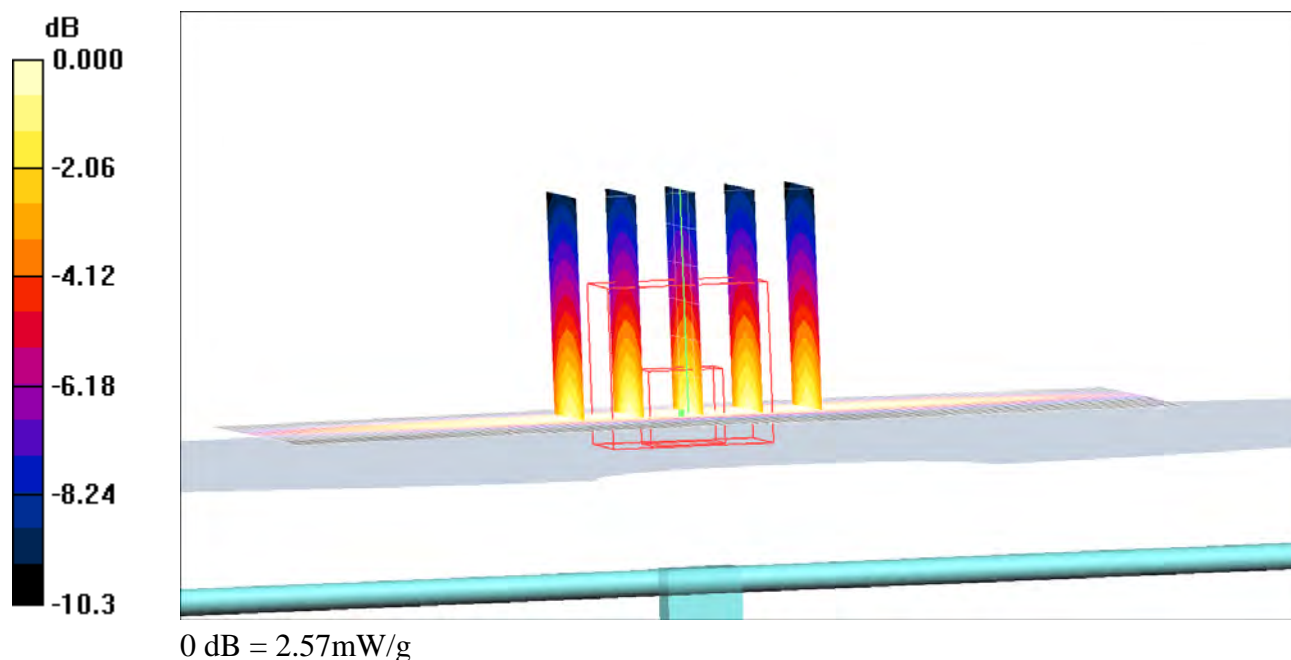

Date/Time: 1/21/2008 1:52:06 PM

Test Laboratory: Sony Ericsson Mobile Communications International AB

Body-Flat15mm-Magdalena-850Bluetooth-High**DUT: Magdalena; Type: DUT; Serial: #10204**

Communication System: GSM 850; Frequency: 848.8 MHz; Duty Cycle: 1:8.3

Medium parameters used: $f = 848.8$ MHz; $\sigma = 1$ mho/m; $\epsilon_r = 55$; $\rho = 1000$ kg/m³

Phantom section: Flat Section

Measurement Standard: DAS4 (High Precision Assessment)

DASY4 Configuration:

- Probe: ET3DV6 - SN1610; ConvF(6.39, 6.39, 6.39); Calibrated: 11/14/2007
- Sensor-Surface: 4mm (Mechanical Surface Detection)
- Electronics: DAE3 Sn448; Calibrated: 15/11/2007
- Phantom: SAM-3; Type: SAM; Serial: 1436
- Measurement SW: DAS4, V4.7 Build 53; Postprocessing SW: SEMCAD, V1.8 Build 172

Body 3/Area Scan (41x71x1): Measurement grid: dx=15mm, dy=15mm

Maximum value of SAR (interpolated) = 0.247 mW/g

Body 3/Zoom Scan (7x5x5)/Cube 0: Measurement grid: dx=5mm, dy=8mm, dz=8mm

Reference Value = 15.6 V/m; Power Drift = -0.049 dB

Peak SAR (extrapolated) = 0.306 W/kg

SAR(1 g) = 0.232 mW/g; SAR(10 g) = 0.164 mW/g

Maximum value of SAR (measured) = 0.247 mW/g

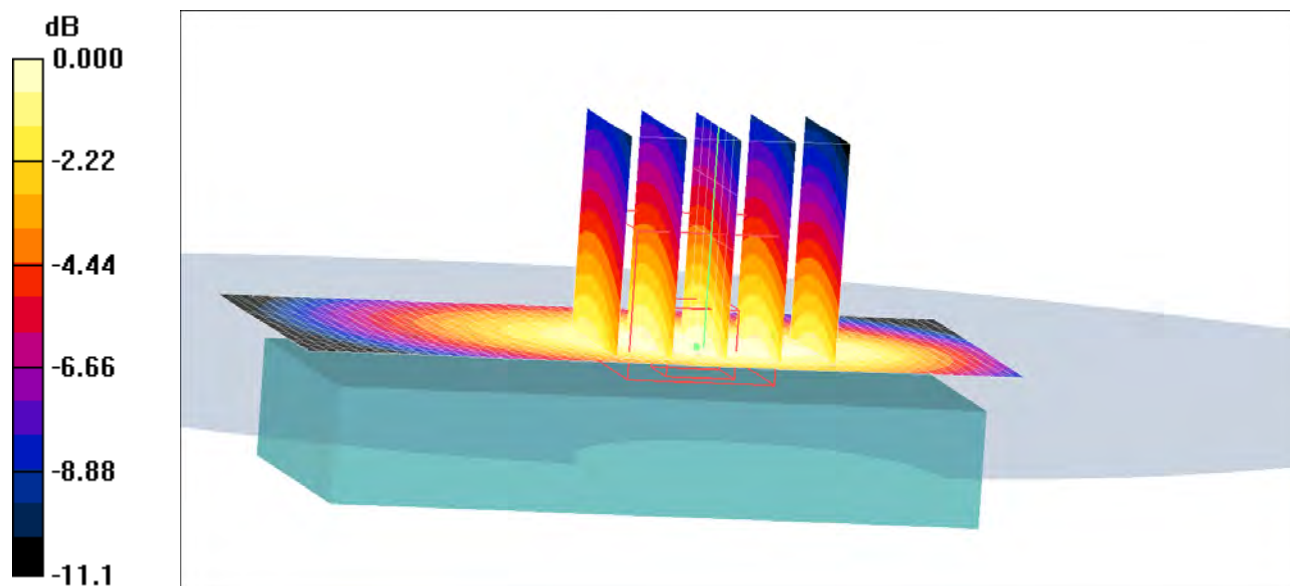

0 dB = 0.247mW/g

Date/Time: 1/21/2008 12:55:32 PM

Test Laboratory: Sony Ericsson Mobile Communications International AB

Body-Flat15mm-Magdalena-850Bluetooth-Low**DUT: Magdalena; Type: DUT; Serial: #10204**

Communication System: GSM 850; Frequency: 824.2 MHz; Duty Cycle: 1:8.3

Medium parameters used: $f = 824.2$ MHz; $\sigma = 0.97$ mho/m; $\epsilon_r = 55.3$; $\rho = 1000$ kg/m³

Phantom section: Flat Section

Measurement Standard: DAS4 (High Precision Assessment)

DASY4 Configuration:

- Probe: ET3DV6 - SN1610; ConvF(6.39, 6.39, 6.39); Calibrated: 11/14/2007
- Sensor-Surface: 4mm (Mechanical Surface Detection)
- Electronics: DAE3 Sn448; Calibrated: 15/11/2007
- Phantom: SAM-3; Type: SAM; Serial: 1436
- Measurement SW: DAS4, V4.7 Build 53; Postprocessing SW: SEMCAD, V1.8 Build 172

Body/Area Scan (41x71x1): Measurement grid: dx=15mm, dy=15mm

Maximum value of SAR (interpolated) = 0.355 mW/g

Body/Zoom Scan (7x5x5)/Cube 0: Measurement grid: dx=5mm, dy=8mm, dz=8mm

Reference Value = 19.0 V/m; Power Drift = -0.162 dB

Peak SAR (extrapolated) = 0.436 W/kg

SAR(1 g) = 0.333 mW/g; SAR(10 g) = 0.236 mW/g

Maximum value of SAR (measured) = 0.355 mW/g

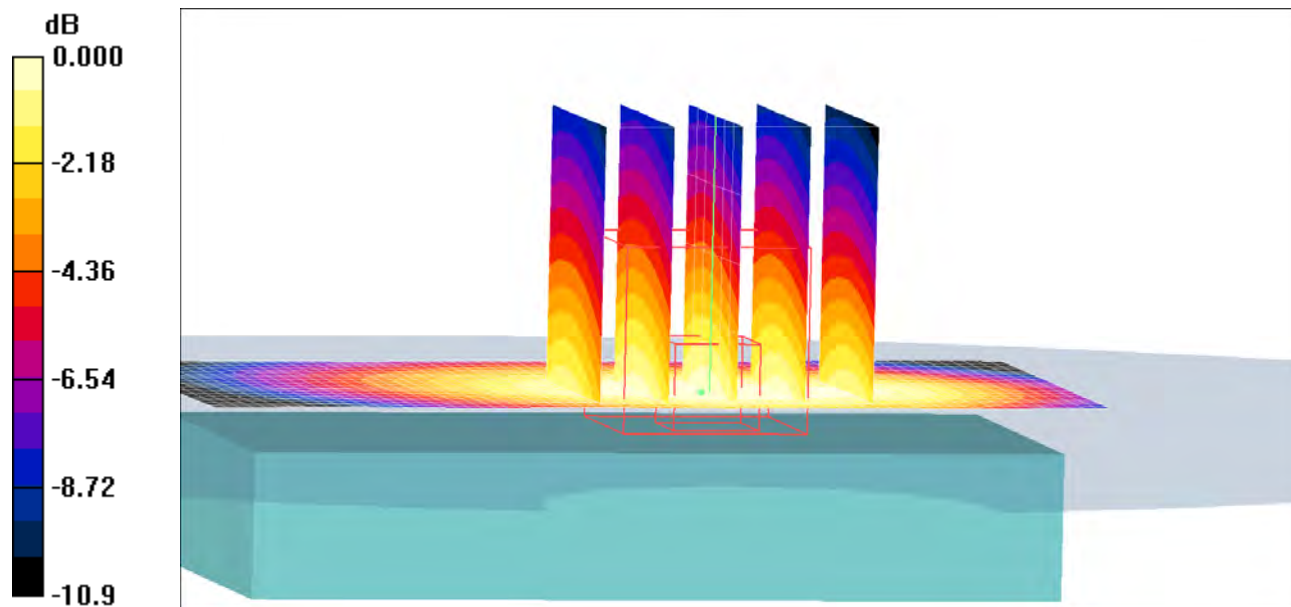

0 dB = 0.355mW/g

Date/Time: 1/21/2008 1:38:32 PM

Test Laboratory: Sony Ericsson Mobile Communications International AB

Body-Flat15mm-Magdalena-850Bluetooth-Middle**DUT: Magdalena; Type: DUT; Serial: #10204**

Communication System: GSM 850; Frequency: 836.6 MHz; Duty Cycle: 1:8.3

Medium parameters used: $f = 836.6$ MHz; $\sigma = 0.99$ mho/m; $\epsilon_r = 54.1$; $\rho = 1000$ kg/m³

Phantom section: Flat Section

Measurement Standard: DAS4 (High Precision Assessment)

DASY4 Configuration:

- Probe: ET3DV6 - SN1610; ConvF(6.39, 6.39, 6.39); Calibrated: 11/14/2007
- Sensor-Surface: 4mm (Mechanical Surface Detection)
- Electronics: DAE3 Sn448; Calibrated: 15/11/2007
- Phantom: SAM-3; Type: SAM; Serial: 1436
- Measurement SW: DAS4, V4.7 Build 53; Postprocessing SW: SEMCAD, V1.8 Build 172

Body 2/Area Scan (41x71x1): Measurement grid: dx=15mm, dy=15mm

Maximum value of SAR (interpolated) = 0.281 mW/g

Body 2/Zoom Scan (7x5x5)/Cube 0: Measurement grid: dx=5mm, dy=8mm, dz=8mm

Reference Value = 16.7 V/m; Power Drift = -0.042 dB

Peak SAR (extrapolated) = 0.351 W/kg

SAR(1 g) = 0.265 mW/g; SAR(10 g) = 0.188 mW/g

Maximum value of SAR (measured) = 0.284 mW/g

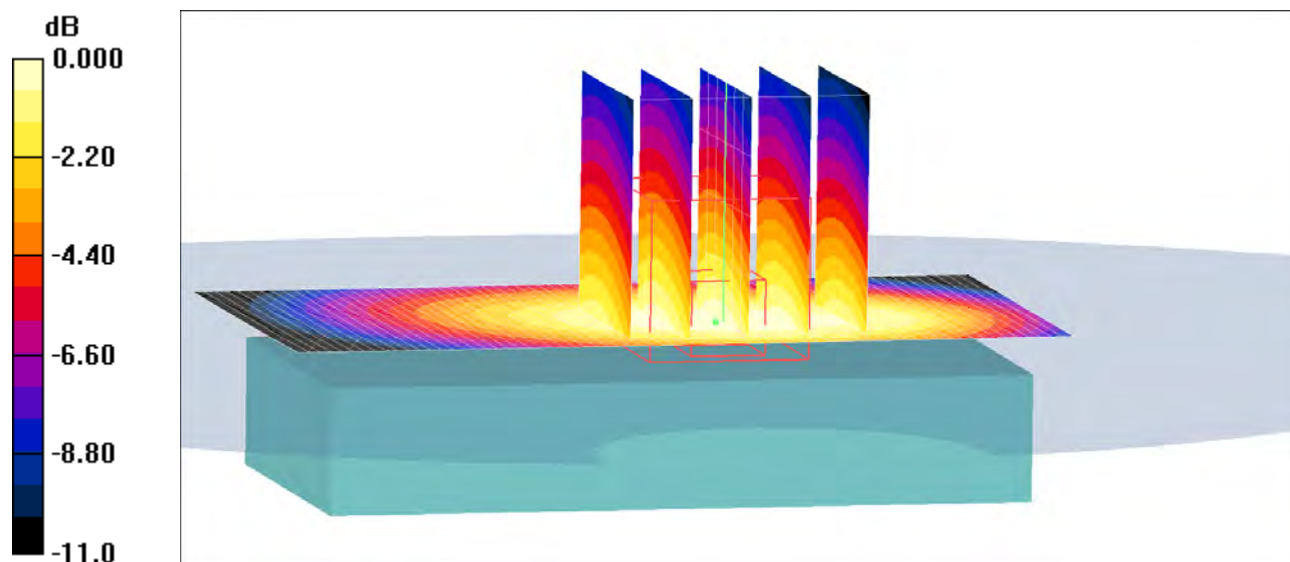

0 dB = 0.284mW/g

Date/Time: 1/21/2008 11:36:35 AM

Test Laboratory: Sony Ericsson Mobile Communications International AB

Body-Flat15mm-Magdalena-850EDGE-Low**DUT: Magdalena; Type: DUT; Serial: #10204**

Communication System: GSM 850; Frequency: 824.2 MHz; Duty Cycle: 1:4.15

Medium parameters used: $f = 824.2$ MHz; $\sigma = 0.97$ mho/m; $\epsilon_r = 55.3$; $\rho = 1000$ kg/m³

Phantom section: Flat Section

Measurement Standard: DAS4 (High Precision Assessment)

DASY4 Configuration:

- Probe: ET3DV6 - SN1610; ConvF(6.39, 6.39, 6.39); Calibrated: 11/14/2007
- Sensor-Surface: 4mm (Mechanical Surface Detection)
- Electronics: DAE3 Sn448; Calibrated: 15/11/2007
- Phantom: SAM-3; Type: SAM; Serial: 1436
- Measurement SW: DAS4, V4.7 Build 53; Postprocessing SW: SEMCAD, V1.8 Build 172

Body/Area Scan (41x71x1): Measurement grid: dx=15mm, dy=15mm

Maximum value of SAR (interpolated) = 0.167 mW/g

Body/Zoom Scan (7x5x5)/Cube 0: Measurement grid: dx=5mm, dy=8mm, dz=8mm

Reference Value = 12.5 V/m; Power Drift = -0.009 dB

Peak SAR (extrapolated) = 0.228 W/kg

SAR(1 g) = 0.160 mW/g; SAR(10 g) = 0.112 mW/g

Maximum value of SAR (measured) = 0.178 mW/g

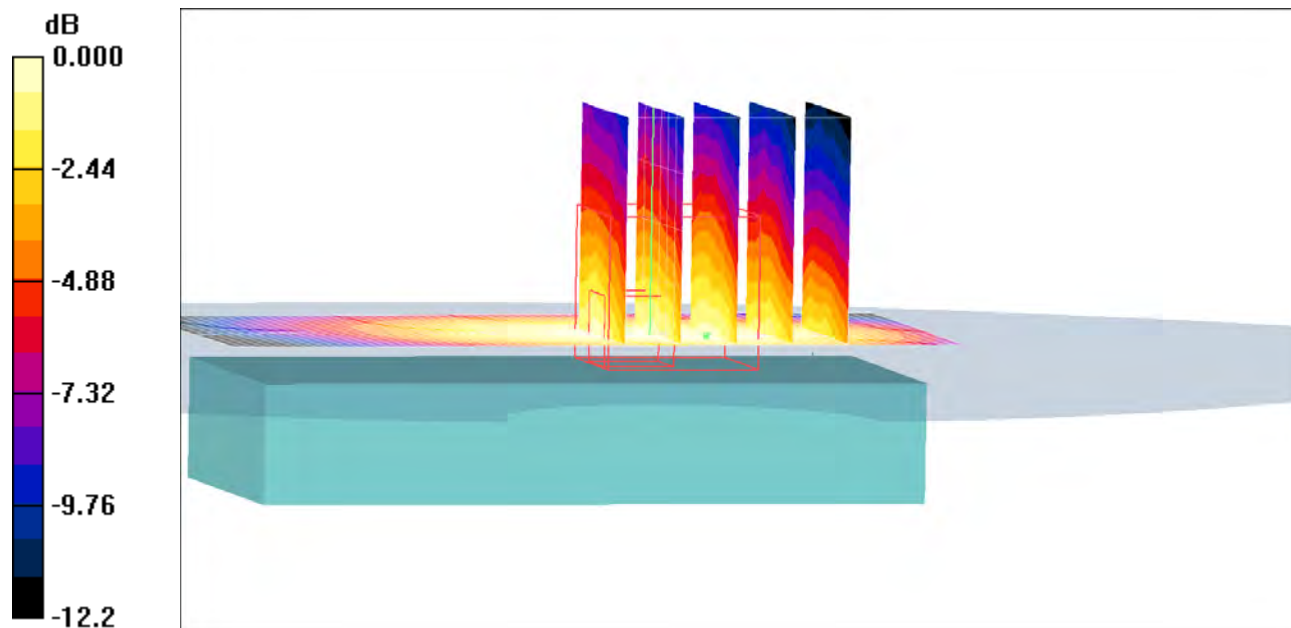

0 dB = 0.178mW/g

Date/Time: 1/21/2008 3:18:06 PM

Test Laboratory: Sony Ericsson Mobile Communications International AB

Body-Flat15mm-Magdalena-850-Front-to-Phantom-Low**DUT: Magdalena; Type: DUT; Serial: #10204**

Communication System: GSM 850; Frequency: 824.2 MHz; Duty Cycle: 1:4.15

Medium parameters used: $f = 824.2$ MHz; $\sigma = 0.97$ mho/m; $\epsilon_r = 55.3$; $\rho = 1000$ kg/m³

Phantom section: Flat Section

Measurement Standard: DAS4 (High Precision Assessment)

DASY4 Configuration:

- Probe: ET3DV6 - SN1610; ConvF(6.39, 6.39, 6.39); Calibrated: 11/14/2007
- Sensor-Surface: 4mm (Mechanical Surface Detection)
- Electronics: DAE3 Sn448; Calibrated: 15/11/2007
- Phantom: SAM-3; Type: SAM; Serial: 1436
- Measurement SW: DAS4, V4.7 Build 53; Postprocessing SW: SEMCAD, V1.8 Build 172

Body/Area Scan (41x71x1): Measurement grid: dx=15mm, dy=15mm

Maximum value of SAR (interpolated) = 0.292 mW/g

Body/Zoom Scan (7x5x5)/Cube 0: Measurement grid: dx=5mm, dy=8mm, dz=8mm

Reference Value = 16.3 V/m; Power Drift = -0.074 dB

Peak SAR (extrapolated) = 0.351 W/kg

SAR(1 g) = 0.273 mW/g; SAR(10 g) = 0.199 mW/g

Maximum value of SAR (measured) = 0.289 mW/g

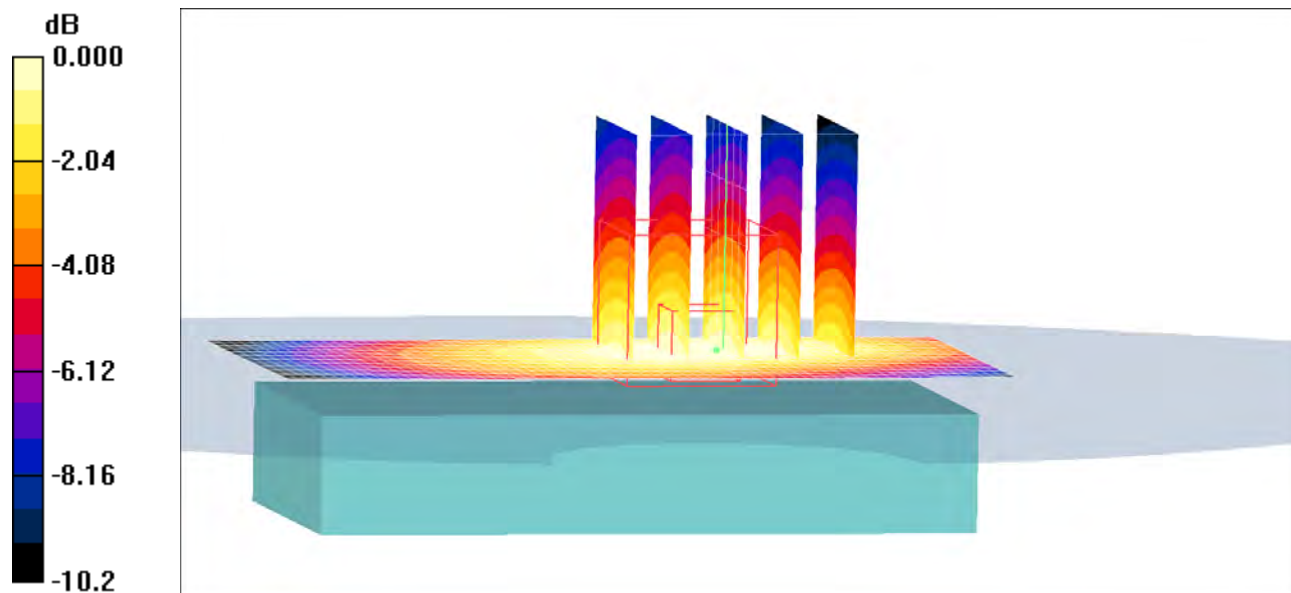

Date/Time: 1/21/2008 11:19:19 AM

Test Laboratory: Sony Ericsson Mobile Communications International AB

Body-Flat15mm-Magdalena-850GPRS-High**DUT: Magdalena; Type: DUT; Serial: #10204**

Communication System: GSM 850; Frequency: 848.8 MHz; Duty Cycle: 1:4.15

Medium parameters used: $f = 848.8 \text{ MHz}$; $\sigma = 1 \text{ mho/m}$; $\epsilon_r = 55$; $\rho = 1000 \text{ kg/m}^3$

Phantom section: Flat Section

Measurement Standard: DAS4 (High Precision Assessment)

DASY4 Configuration:

- Probe: ET3DV6 - SN1610; ConvF(6.39, 6.39, 6.39); Calibrated: 11/14/2007
- Sensor-Surface: 4mm (Mechanical Surface Detection)
- Electronics: DAE3 Sn448; Calibrated: 15/11/2007
- Phantom: SAM-3; Type: SAM; Serial: 1436
- Measurement SW: DAS4, V4.7 Build 53; Postprocessing SW: SEMCAD, V1.8 Build 172

Body 3/Area Scan (41x71x1): Measurement grid: $dx=15\text{mm}$, $dy=15\text{mm}$

Maximum value of SAR (interpolated) = 0.455 mW/g

Body 3/Zoom Scan (7x5x5)/Cube 0: Measurement grid: $dx=5\text{mm}$, $dy=8\text{mm}$, $dz=8\text{mm}$

Reference Value = 21.1 V/m; Power Drift = -0.143 dB

Peak SAR (extrapolated) = 0.567 W/kg

SAR(1 g) = 0.430 mW/g; SAR(10 g) = 0.304 mW/g

Maximum value of SAR (measured) = 0.460 mW/g

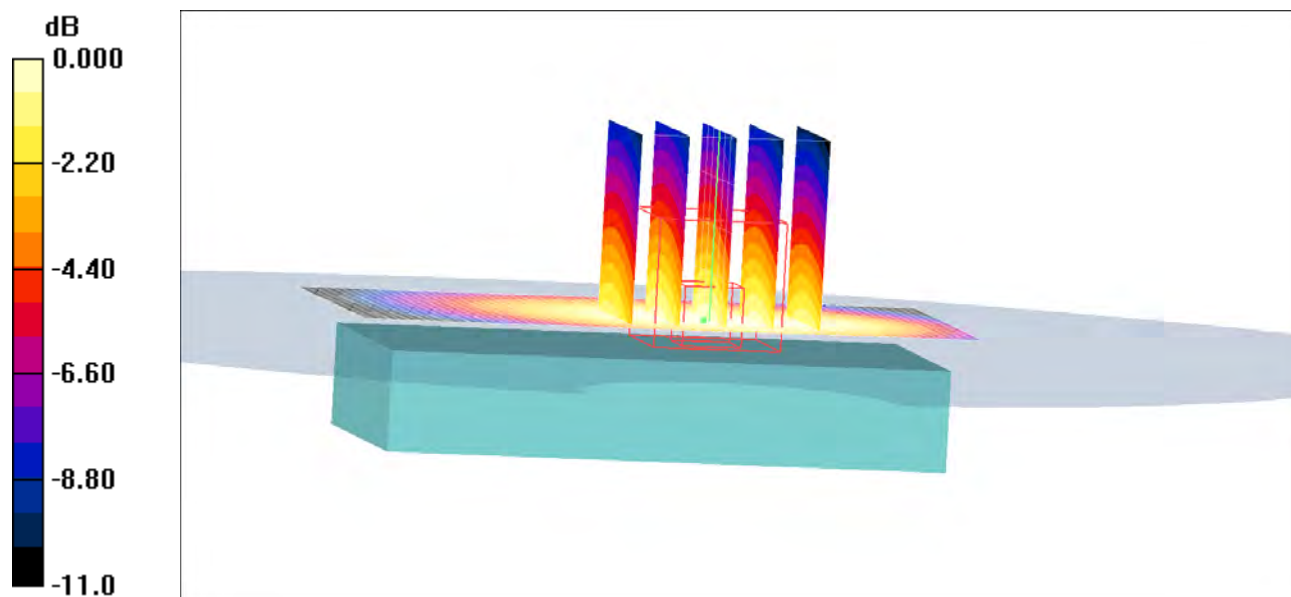

0 dB = 0.460mW/g

Date/Time: 1/21/2008 10:31:13 AM

Test Laboratory: Sony Ericsson Mobile Communications International AB

Body-Flat15mm-Magdalena-850GPRS-Low**DUT: Magdalena; Type: DUT; Serial: #10204**

Communication System: GSM 850; Frequency: 824.2 MHz; Duty Cycle: 1:4.15

Medium parameters used: $f = 824.2$ MHz; $\sigma = 0.97$ mho/m; $\epsilon_r = 55.3$; $\rho = 1000$ kg/m³

Phantom section: Flat Section

Measurement Standard: DAS4 (High Precision Assessment)

DASY4 Configuration:

- Probe: ET3DV6 - SN1610; ConvF(6.39, 6.39, 6.39); Calibrated: 11/14/2007
- Sensor-Surface: 4mm (Mechanical Surface Detection)
- Electronics: DAE3 Sn448; Calibrated: 15/11/2007
- Phantom: SAM-3; Type: SAM; Serial: 1436
- Measurement SW: DAS4, V4.7 Build 53; Postprocessing SW: SEMCAD, V1.8 Build 172

Body/Area Scan (41x71x1): Measurement grid: dx=15mm, dy=15mm

Maximum value of SAR (interpolated) = 0.670 mW/g

Body/Zoom Scan (7x5x5)/Cube 0: Measurement grid: dx=5mm, dy=8mm, dz=8mm

Reference Value = 25.9 V/m; Power Drift = -0.161 dB

Peak SAR (extrapolated) = 0.827 W/kg

SAR(1 g) = 0.631 mW/g; SAR(10 g) = 0.448 mW/g

Maximum value of SAR (measured) = 0.676 mW/g

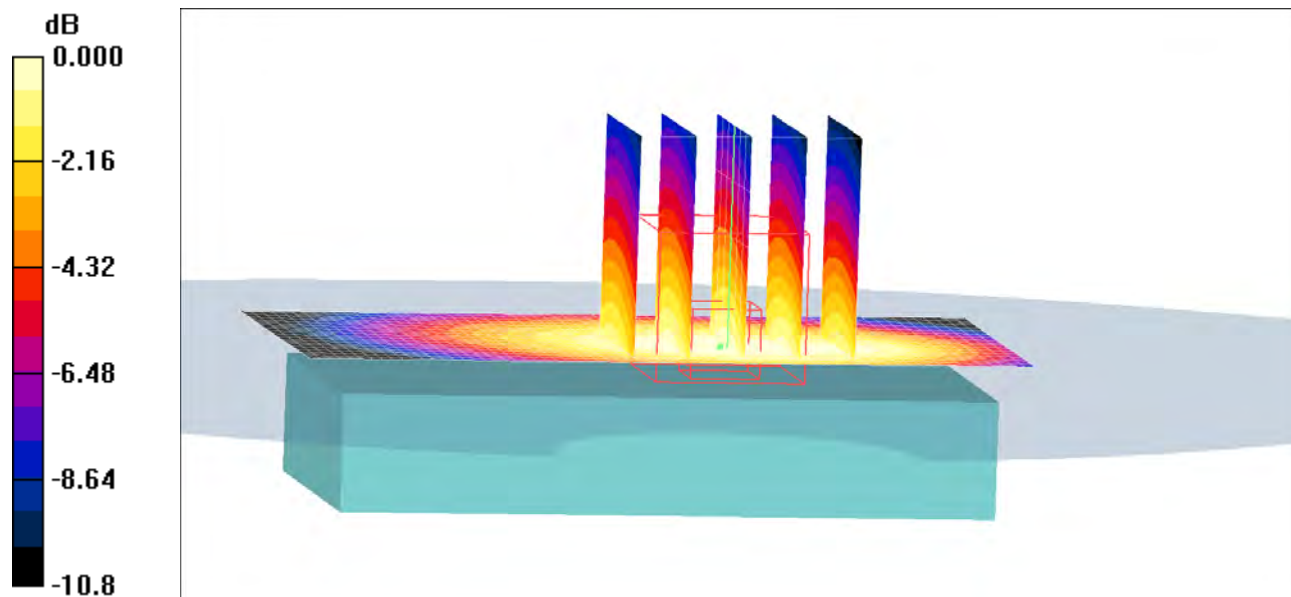

0 dB = 0.676mW/g

Date/Time: 1/21/2008 10:46:25 AM

Test Laboratory: Sony Ericsson Mobile Communications International AB

Body-Flat15mm-Magdalena-850GPRS-Middle**DUT: Magdalena; Type: DUT; Serial: #10204**

Communication System: GSM 850; Frequency: 836.6 MHz; Duty Cycle: 1:4.15

Medium parameters used: $f = 836.6$ MHz; $\sigma = 0.99$ mho/m; $\epsilon_r = 54.1$; $\rho = 1000$ kg/m³

Phantom section: Flat Section

Measurement Standard: DAS4 (High Precision Assessment)

DASY4 Configuration:

- Probe: ET3DV6 - SN1610; ConvF(6.39, 6.39, 6.39); Calibrated: 11/14/2007
- Sensor-Surface: 4mm (Mechanical Surface Detection)
- Electronics: DAE3 Sn448; Calibrated: 15/11/2007
- Phantom: SAM-3; Type: SAM; Serial: 1436
- Measurement SW: DAS4, V4.7 Build 53; Postprocessing SW: SEMCAD, V1.8 Build 172

Body 2/Area Scan (41x71x1): Measurement grid: dx=15mm, dy=15mm

Maximum value of SAR (interpolated) = 0.541 mW/g

Body 2/Zoom Scan (7x5x5)/Cube 0: Measurement grid: dx=5mm, dy=8mm, dz=8mm

Reference Value = 22.9 V/m; Power Drift = -0.143 dB

Peak SAR (extrapolated) = 0.662 W/kg

SAR(1 g) = 0.507 mW/g; SAR(10 g) = 0.360 mW/g

Maximum value of SAR (measured) = 0.537 mW/g

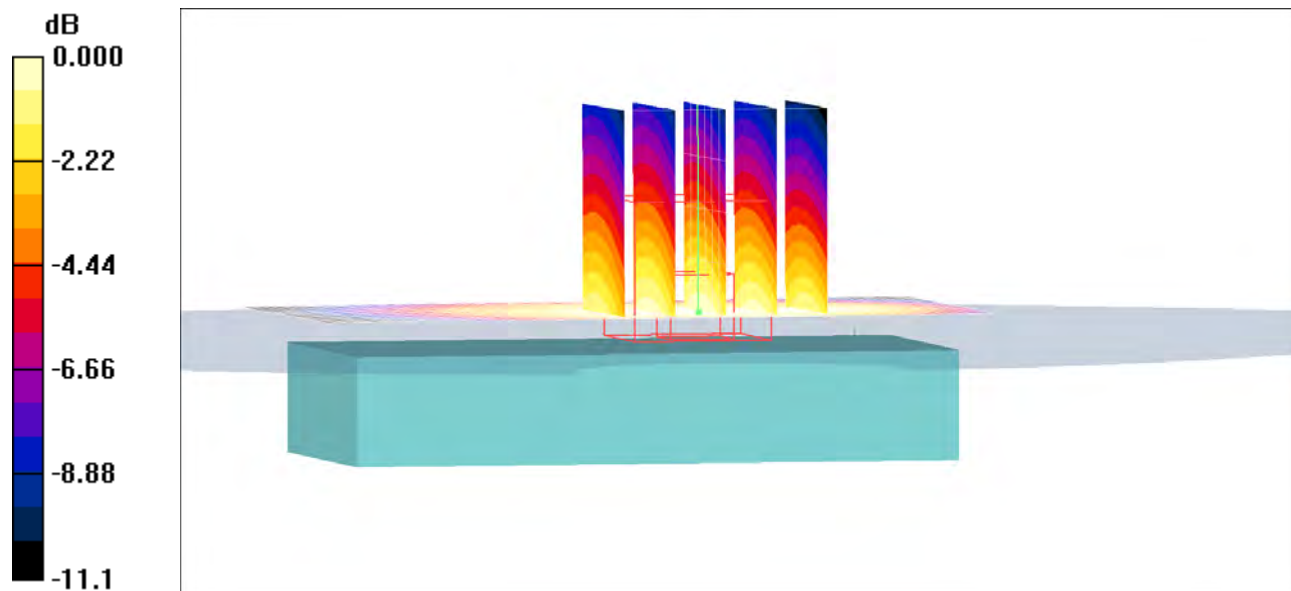

0 dB = 0.537mW/g

Date/Time: 1/21/2008 2:20:54 PM

Test Laboratory: Sony Ericsson Mobile Communications International AB

Body-Flat15mm-Magdalena-850PHF-Low**DUT: Magdalena; Type: DUT; Serial: #10204**

Communication System: GSM 850; Frequency: 824.2 MHz; Duty Cycle: 1:8.3

Medium parameters used: $f = 824.2$ MHz; $\sigma = 0.97$ mho/m; $\epsilon_r = 55.3$; $\rho = 1000$ kg/m³

Phantom section: Flat Section

Measurement Standard: DAS4 (High Precision Assessment)

DASY4 Configuration:

- Probe: ET3DV6 - SN1610; ConvF(6.39, 6.39, 6.39); Calibrated: 11/14/2007
- Sensor-Surface: 4mm (Mechanical Surface Detection)
- Electronics: DAE3 Sn448; Calibrated: 15/11/2007
- Phantom: SAM-3; Type: SAM; Serial: 1436
- Measurement SW: DAS4, V4.7 Build 53; Postprocessing SW: SEMCAD, V1.8 Build 172

Body/Area Scan (41x71x1): Measurement grid: dx=15mm, dy=15mm

Maximum value of SAR (interpolated) = 0.299 mW/g

Body/Zoom Scan (7x5x5)/Cube 0: Measurement grid: dx=5mm, dy=8mm, dz=8mm

Reference Value = 17.5 V/m; Power Drift = -0.090 dB

Peak SAR (extrapolated) = 0.376 W/kg

SAR(1 g) = 0.285 mW/g; SAR(10 g) = 0.203 mW/g

Maximum value of SAR (measured) = 0.303 mW/g

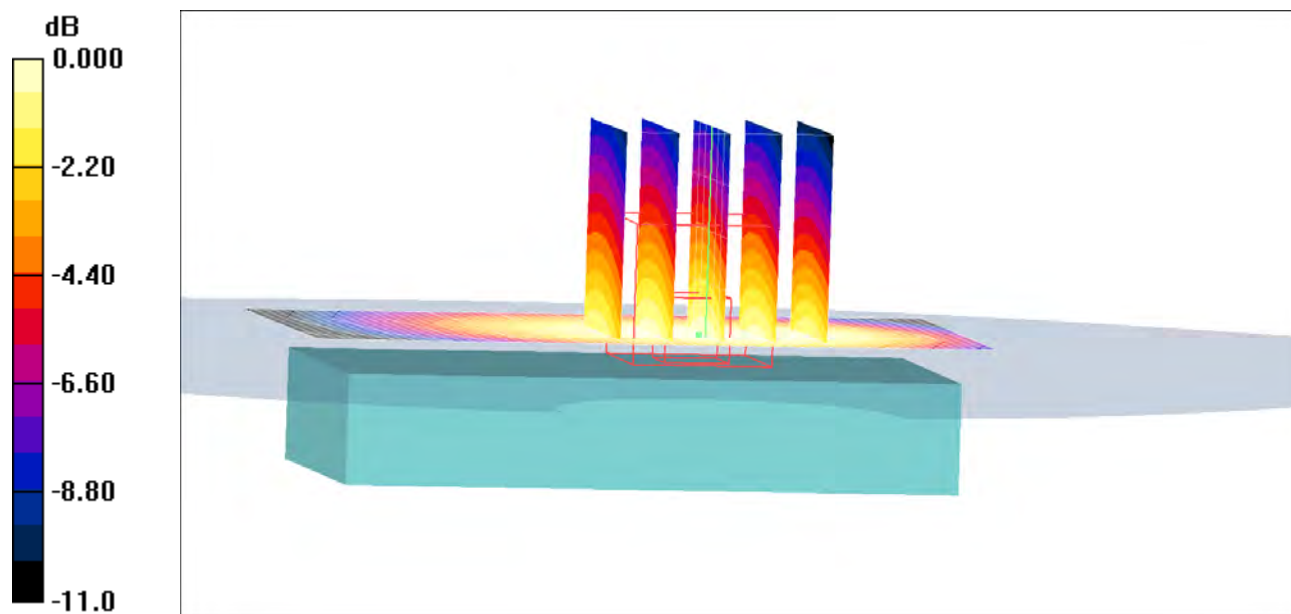

0 dB = 0.303mW/g

Date/Time: 1/16/2008 1:52:11 PM

Test Laboratory: Sony Ericsson Mobile Communications International AB

Magdalena-LeftHandSide-GSM850-Tilt-Middle**DUT: Magdalena; Type: DUT; Serial: #10204**

Communication System: GSM 850; Frequency: 836.6 MHz; Duty Cycle: 1:8.3

Medium parameters used: $f = 836.6$ MHz; $\sigma = 0.86$ mho/m; $\epsilon_r = 39.6$; $\rho = 1000$ kg/m³

Phantom section: Left Section

Measurement Standard: DAS4 (High Precision Assessment)

DASY4 Configuration:

- Probe: ET3DV6 - SN1610; ConvF(6.69, 6.69, 6.69); Calibrated: 11/14/2007
 - Sensor-Surface: 4mm (Mechanical Surface Detection)
 - Electronics: DAE3 Sn448; Calibrated: 15/11/2007
 - Phantom: SAM-2; Type: SAM; Serial: 1025
 - Measurement SW: DAS4, V4.7 Build 53; Postprocessing SW: SEMCAD, V1.8 Build 172
- Tilt position - Middle/Area Scan (71x131x1):** Measurement grid: dx=10mm, dy=10mm
Maximum value of SAR (interpolated) = 0.262 mW/g
- Tilt position - Middle/Zoom Scan (5x5x7) (5x5x7)/Cube 0:** Measurement grid:
dx=8mm, dy=8mm, dz=5mm
Reference Value = 10.5 V/m; Power Drift = -0.037 dB
Peak SAR (extrapolated) = 0.299 W/kg
SAR(1 g) = 0.248 mW/g; SAR(10 g) = 0.187 mW/g
Maximum value of SAR (measured) = 0.260 mW/g

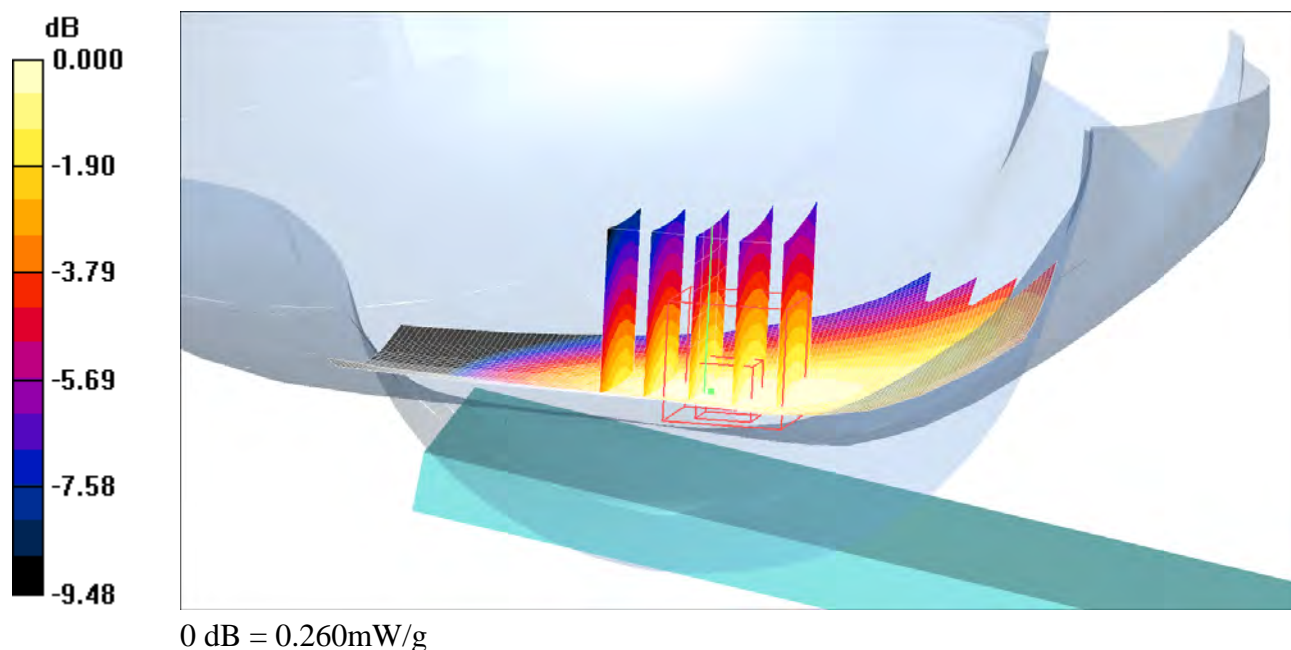

Date/Time: 1/16/2008 2:39:34 PM

Test Laboratory: Sony Ericsson Mobile Communications International AB

Magdalena-LeftHandSide-GSM850-Touch-High**DUT: Magdalena; Type: DUT; Serial: #10204**

Communication System: GSM 850; Frequency: 848.8 MHz; Duty Cycle: 1:8.3

Medium parameters used: $f = 848.8$ MHz; $\sigma = 0.87$ mho/m; $\epsilon_r = 39.5$; $\rho = 1000$ kg/m³

Phantom section: Left Section

Measurement Standard: DAS4 (High Precision Assessment)

DASY4 Configuration:

- Probe: ET3DV6 - SN1610; ConvF(6.69, 6.69, 6.69); Calibrated: 11/14/2007
- Sensor-Surface: 4mm (Mechanical Surface Detection)
- Electronics: DAE3 Sn448; Calibrated: 15/11/2007
- Phantom: SAM-2; Type: SAM; Serial: 1025
- Measurement SW: DAS4, V4.7 Build 53; Postprocessing SW: SEMCAD, V1.8 Build 172

Touch - High/Area Scan (71x131x1): Measurement grid: dx=10mm, dy=10mm

Maximum value of SAR (interpolated) = 0.712 mW/g

Touch - High/Zoom Scan (5x5x7) (5x5x7)/Cube 0: Measurement grid: dx=8mm, dy=8mm, dz=5mm

Reference Value = 4.68 V/m; Power Drift = -0.055 dB

Peak SAR (extrapolated) = 1.10 W/kg

SAR(1 g) = 0.652 mW/g; SAR(10 g) = 0.424 mW/g

Maximum value of SAR (measured) = 0.725 mW/g

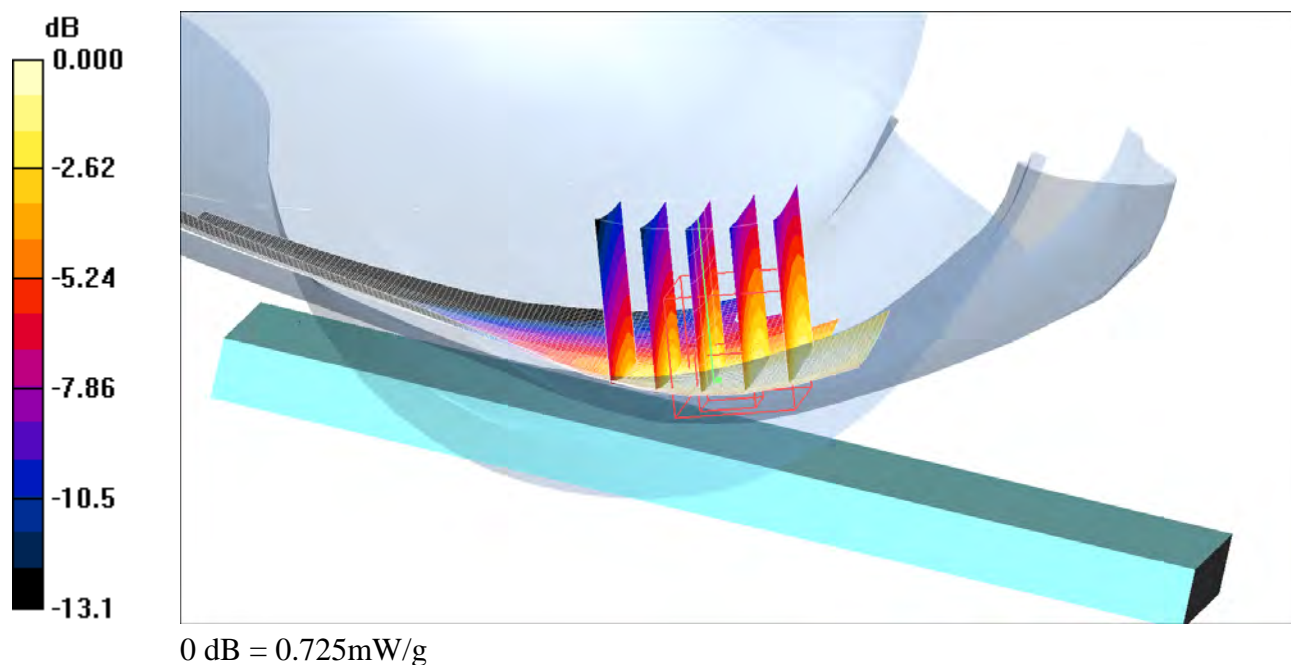

Date/Time: 1/16/2008 2:16:37 PM

Test Laboratory: Sony Ericsson Mobile Communications International AB

Magdalena-LeftHandSide-GSM850-Touch-Low**DUT: Magdalena; Type: DUT; Serial: #10204**

Communication System: GSM 850; Frequency: 824.2 MHz; Duty Cycle: 1:8.3

Medium parameters used: $f = 824.2$ MHz; $\sigma = 0.85$ mho/m; $\epsilon_r = 39.8$; $\rho = 1000$ kg/m³

Phantom section: Left Section

Measurement Standard: DAS4 (High Precision Assessment)

DASY4 Configuration:

- Probe: ET3DV6 - SN1610; ConvF(6.69, 6.69, 6.69); Calibrated: 11/14/2007
- Sensor-Surface: 4mm (Mechanical Surface Detection)
- Electronics: DAE3 Sn448; Calibrated: 15/11/2007
- Phantom: SAM-2; Type: SAM; Serial: 1025
- Measurement SW: DAS4, V4.7 Build 53; Postprocessing SW: SEMCAD, V1.8 Build 172

Touch - Low/Area Scan (71x131x1): Measurement grid: dx=10mm, dy=10mm

Maximum value of SAR (interpolated) = 0.628 mW/g

Touch - Low/Zoom Scan (5x5x7) (5x5x7)/Cube 0: Measurement grid: dx=8mm, dy=8mm, dz=5mm

Reference Value = 4.13 V/m; Power Drift = -0.105 dB

Peak SAR (extrapolated) = 1.00 W/kg

SAR(1 g) = 0.576 mW/g; SAR(10 g) = 0.401 mW/g

Maximum value of SAR (measured) = 0.616 mW/g

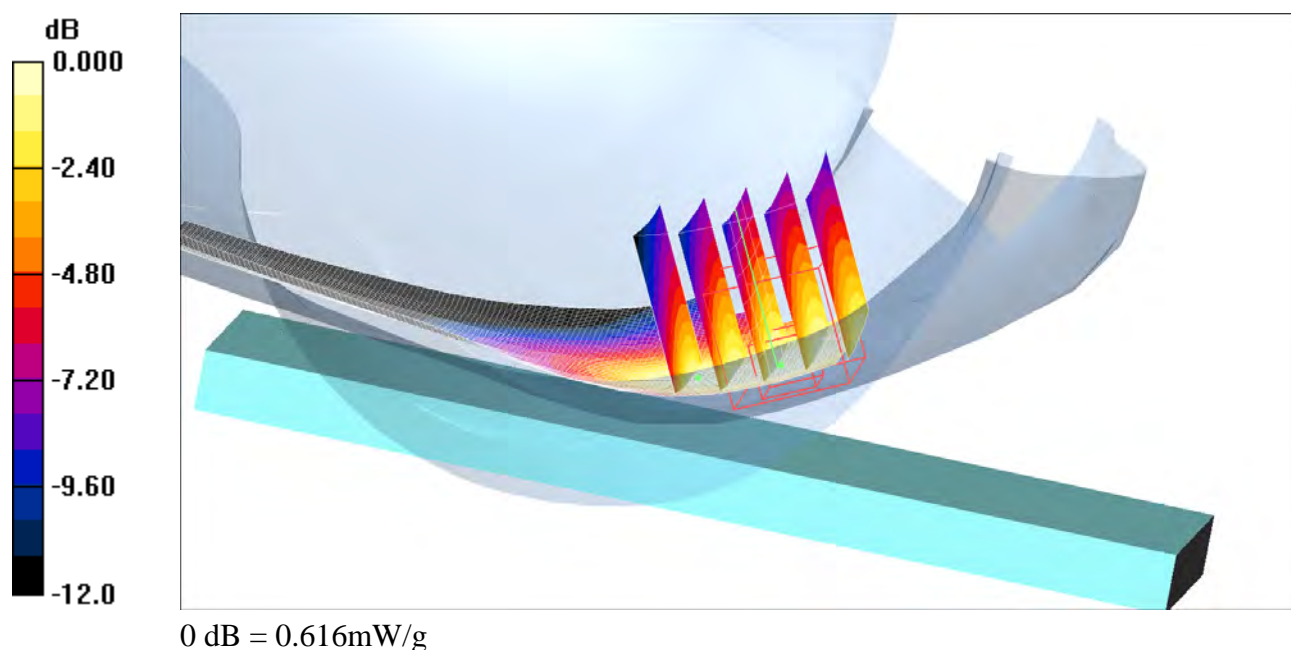

Date/Time: 1/16/2008 1:29:42 PM

Test Laboratory: Sony Ericsson Mobile Communications International AB

Magdalena-LeftHandSide-GSM850-Touch-Middle**DUT: Magdalena; Type: DUT; Serial: #10204**

Communication System: GSM 850; Frequency: 836.6 MHz; Duty Cycle: 1:8.3

Medium parameters used: $f = 836.6$ MHz; $\sigma = 0.86$ mho/m; $\epsilon_r = 39.6$; $\rho = 1000$ kg/m³

Phantom section: Left Section

Measurement Standard: DAS4 (High Precision Assessment)

DASY4 Configuration:

- Probe: ET3DV6 - SN1610; ConvF(6.69, 6.69, 6.69); Calibrated: 11/14/2007
- Sensor-Surface: 4mm (Mechanical Surface Detection)
- Electronics: DAE3 Sn448; Calibrated: 15/11/2007
- Phantom: SAM-2; Type: SAM; Serial: 1025
- Measurement SW: DAS4, V4.7 Build 53; Postprocessing SW: SEMCAD, V1.8 Build 172

Touch position - Middle/Area Scan (71x131x1): Measurement grid: dx=10mm, dy=10mm

Maximum value of SAR (interpolated) = 0.734 mW/g

Touch position - Middle/Zoom Scan (5x5x7) (5x5x7)/Cube 0: Measurement grid: dx=8mm, dy=8mm, dz=5mm

Reference Value = 4.34 V/m; Power Drift = -0.018 dB

Peak SAR (extrapolated) = 1.13 W/kg

SAR(1 g) = 0.672 mW/g; SAR(10 g) = 0.467 mW/g

Maximum value of SAR (measured) = 0.719 mW/g

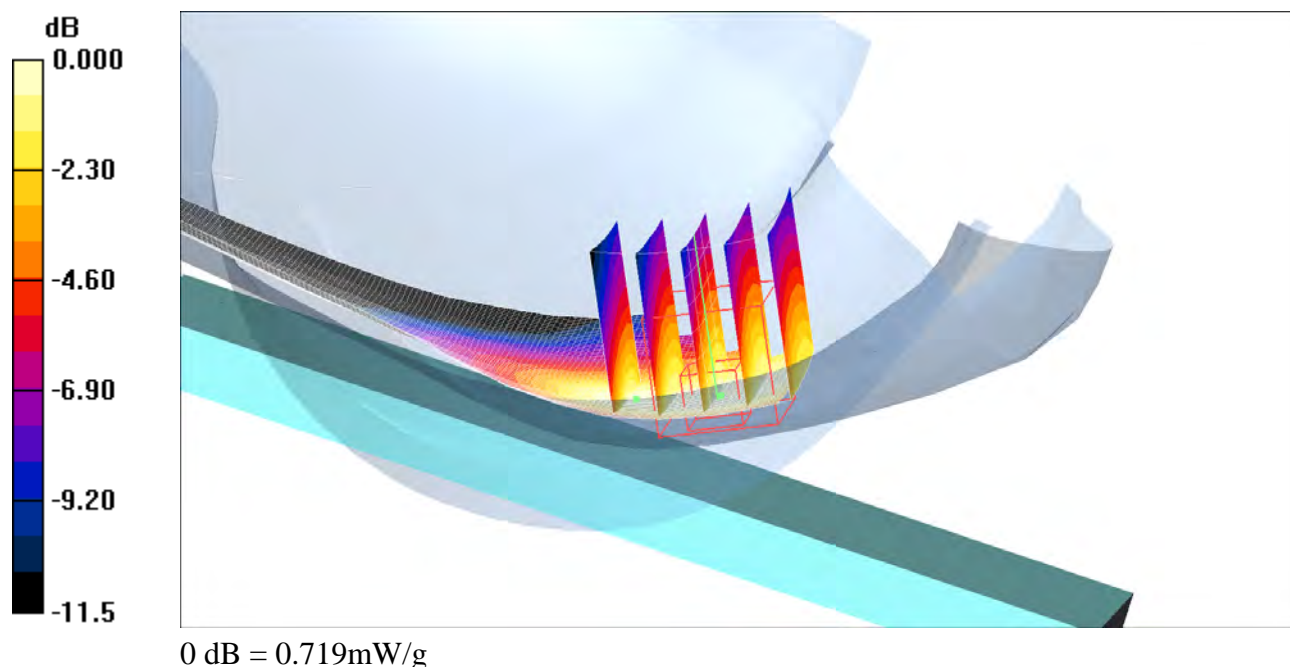

Date/Time: 1/16/2008 3:28:35 PM

Test Laboratory: Sony Ericsson Mobile Communications International AB

Magdalena-RightHandSide-GSM850-Tilt-Middle**DUT: Magdalena; Type: DUT; Serial: #10204**

Communication System: GSM 850; Frequency: 836.6 MHz; Duty Cycle: 1:8.3

Medium parameters used: $f = 836.6$ MHz; $\sigma = 0.86$ mho/m; $\epsilon_r = 39.6$; $\rho = 1000$ kg/m³

Phantom section: Right Section

Measurement Standard: DAS4 (High Precision Assessment)

DASY4 Configuration:

- Probe: ET3DV6 - SN1610; ConvF(6.69, 6.69, 6.69); Calibrated: 11/14/2007
 - Sensor-Surface: 4mm (Mechanical Surface Detection)
 - Electronics: DAE3 Sn448; Calibrated: 15/11/2007
 - Phantom: SAM-2; Type: SAM; Serial: 1025
 - Measurement SW: DAS4, V4.7 Build 53; Postprocessing SW: SEMCAD, V1.8 Build 172
- Tilt position - Middle/Area Scan (71x131x1):** Measurement grid: dx=10mm, dy=10mm
Maximum value of SAR (interpolated) = 0.248 mW/g
- Tilt position - Middle/Zoom Scan (5x5x7) (5x5x7)/Cube 0:** Measurement grid:
dx=8mm, dy=8mm, dz=5mm
Reference Value = 11.2 V/m; Power Drift = -0.068 dB
Peak SAR (extrapolated) = 0.276 W/kg
SAR(1 g) = 0.233 mW/g; SAR(10 g) = 0.178 mW/g
Maximum value of SAR (measured) = 0.244 mW/g

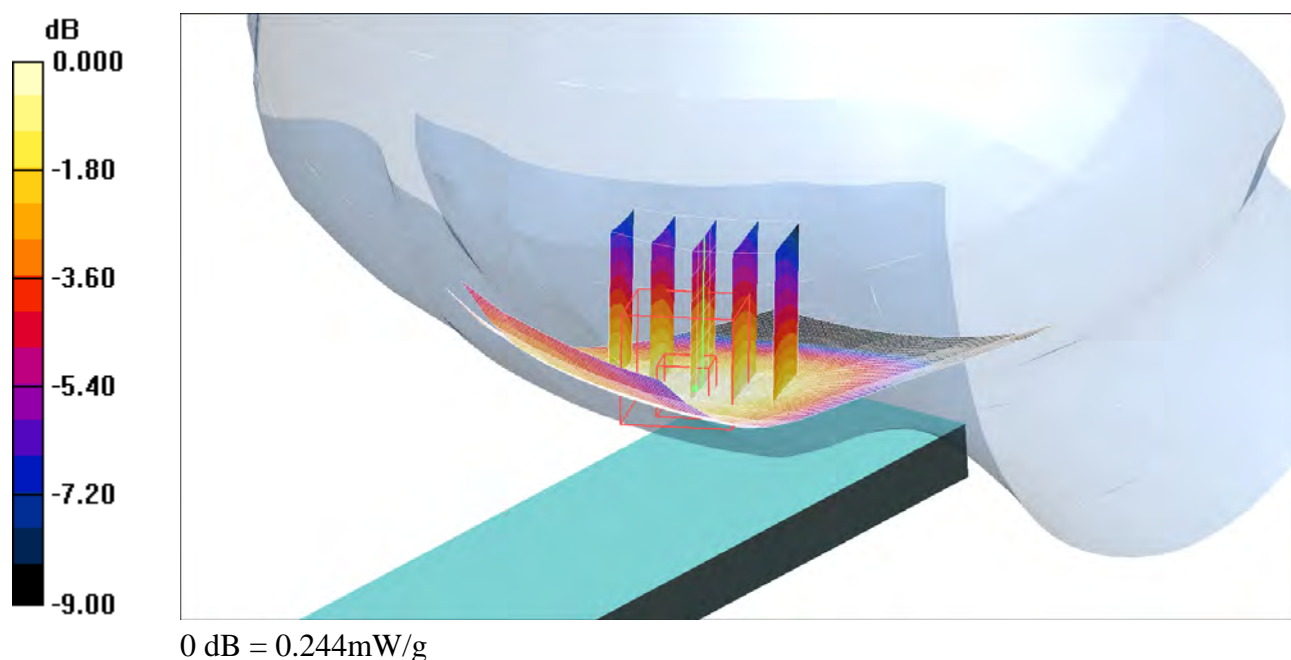

Date/Time: 1/16/2008 4:55:05 PM

Test Laboratory: Sony Ericsson Mobile Communications International AB

Magdalena-RightHandSide-GSM850-Touch-High**DUT: Magdalena; Type: DUT; Serial: #10204**

Communication System: GSM 850; Frequency: 848.8 MHz; Duty Cycle: 1:8.3

Medium parameters used: $f = 848.8$ MHz; $\sigma = 0.87$ mho/m; $\epsilon_r = 39.5$; $\rho = 1000$ kg/m³

Phantom section: Right Section

Measurement Standard: DAS4 (High Precision Assessment)

DASY4 Configuration:

- Probe: ET3DV6 - SN1610; ConvF(6.69, 6.69, 6.69); Calibrated: 11/14/2007
- Sensor-Surface: 4mm (Mechanical Surface Detection)
- Electronics: DAE3 Sn448; Calibrated: 15/11/2007
- Phantom: SAM-2; Type: SAM; Serial: 1025
- Measurement SW: DAS4, V4.7 Build 53; Postprocessing SW: SEMCAD, V1.8 Build 172

Touch - High/Area Scan (71x131x1): Measurement grid: dx=10mm, dy=10mm

Maximum value of SAR (interpolated) = 0.573 mW/g

Touch - High/Zoom Scan (5x5x7) (5x5x7)/Cube 0: Measurement grid: dx=8mm, dy=8mm, dz=5mm

Reference Value = 5.44 V/m; Power Drift = 0.048 dB

Peak SAR (extrapolated) = 0.765 W/kg

SAR(1 g) = 0.533 mW/g; SAR(10 g) = 0.366 mW/g

Maximum value of SAR (measured) = 0.575 mW/g

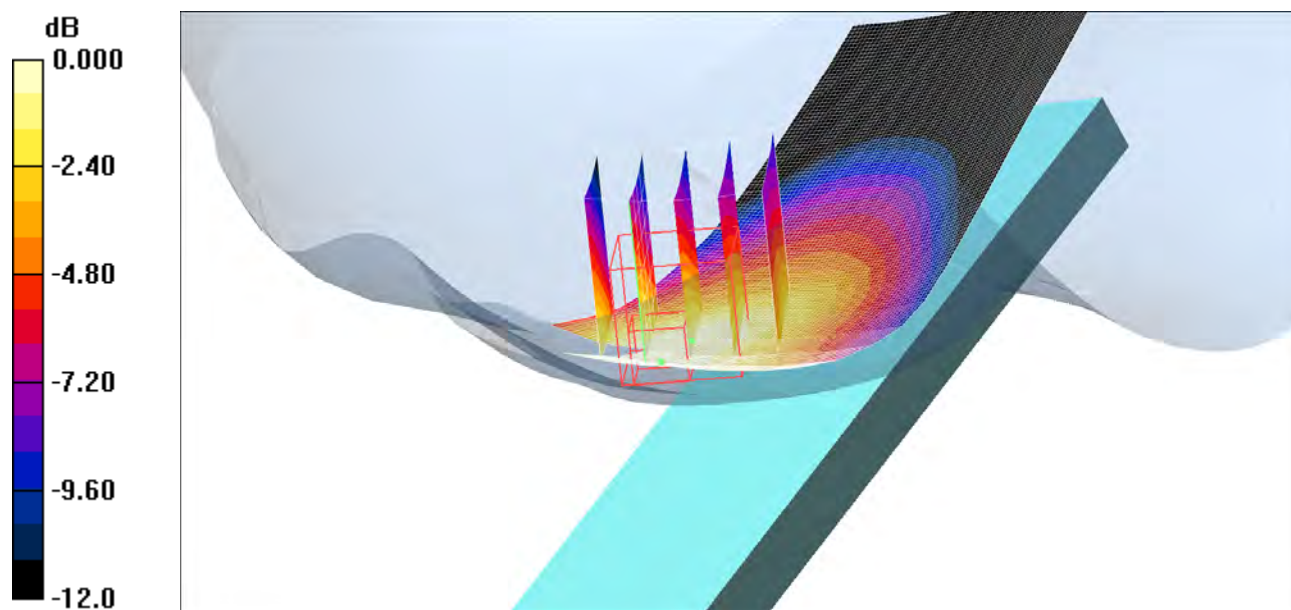

0 dB = 0.575mW/g

Date/Time: 1/16/2008 4:35:07 PM

Test Laboratory: Sony Ericsson Mobile Communications International AB

Magdalena-RightHandSide-GSM850-Touch-Low**DUT: Magdalena; Type: DUT; Serial: #10204**

Communication System: GSM 850; Frequency: 824.2 MHz; Duty Cycle: 1:8.3

Medium parameters used: $f = 824.2$ MHz; $\sigma = 0.85$ mho/m; $\epsilon_r = 39.8$; $\rho = 1000$ kg/m³

Phantom section: Right Section

Measurement Standard: DAS4 (High Precision Assessment)

DASY4 Configuration:

- Probe: ET3DV6 - SN1610; ConvF(6.69, 6.69, 6.69); Calibrated: 11/14/2007
- Sensor-Surface: 4mm (Mechanical Surface Detection)
- Electronics: DAE3 Sn448; Calibrated: 15/11/2007
- Phantom: SAM-2; Type: SAM; Serial: 1025
- Measurement SW: DAS4, V4.7 Build 53; Postprocessing SW: SEMCAD, V1.8 Build 172

Touch - Low/Area Scan (71x131x1): Measurement grid: dx=10mm, dy=10mm

Maximum value of SAR (interpolated) = 0.510 mW/g

Touch - Low/Zoom Scan (5x5x7) (5x5x7)/Cube 0: Measurement grid: dx=8mm, dy=8mm, dz=5mm

Reference Value = 4.77 V/m; Power Drift = -0.111 dB

Peak SAR (extrapolated) = 0.603 W/kg

SAR(1 g) = 0.480 mW/g; SAR(10 g) = 0.352 mW/g

Maximum value of SAR (measured) = 0.510 mW/g

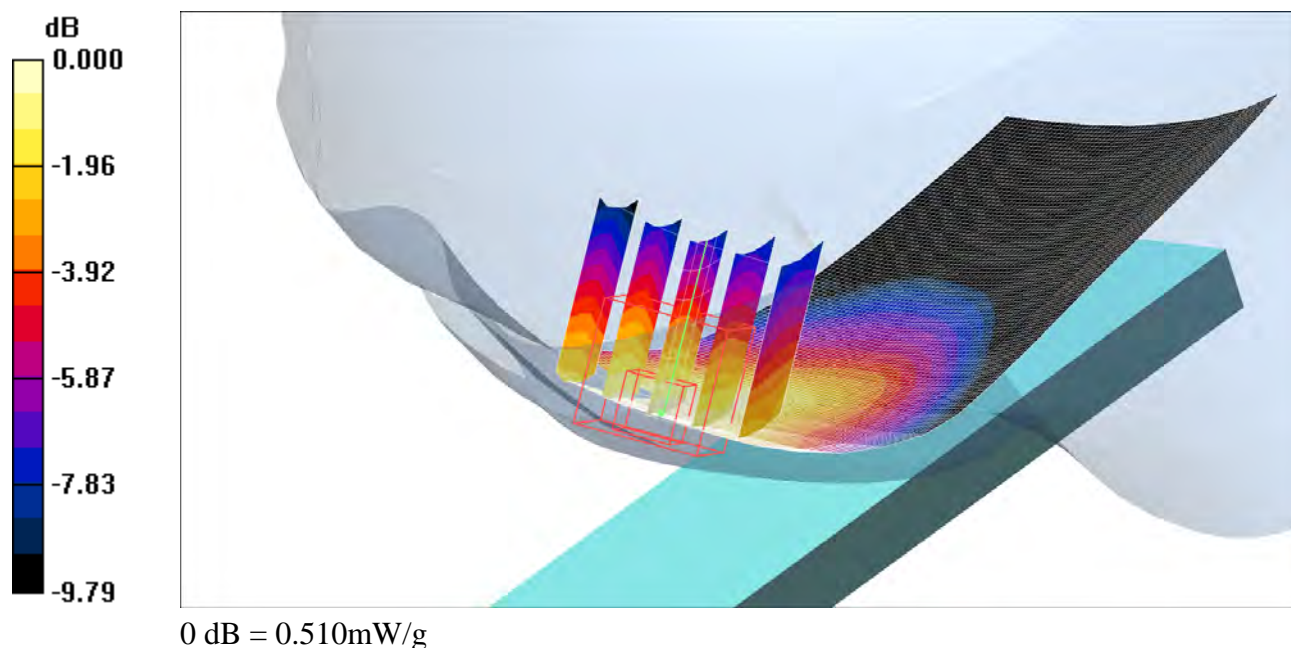

Date/Time: 1/16/2008 3:08:29 PM

Test Laboratory: Sony Ericsson Mobile Communications International AB

Magdalena-RightHandSide-GSM850-Touch-Middle**DUT: Magdalena; Type: DUT; Serial: #10204**

Communication System: GSM 850; Frequency: 836.6 MHz; Duty Cycle: 1:8.3

Medium parameters used: $f = 836.6$ MHz; $\sigma = 0.86$ mho/m; $\epsilon_r = 39.6$; $\rho = 1000$ kg/m³

Phantom section: Right Section

Measurement Standard: DAS4 (High Precision Assessment)

DASY4 Configuration:

- Probe: ET3DV6 - SN1610; ConvF(6.69, 6.69, 6.69); Calibrated: 11/14/2007
- Sensor-Surface: 4mm (Mechanical Surface Detection)
- Electronics: DAE3 Sn448; Calibrated: 15/11/2007
- Phantom: SAM-2; Type: SAM; Serial: 1025
- Measurement SW: DAS4, V4.7 Build 53; Postprocessing SW: SEMCAD, V1.8 Build 172

Touch position - Middle/Area Scan (71x131x1): Measurement grid: dx=10mm, dy=10mm

Maximum value of SAR (interpolated) = 0.594 mW/g

Touch position - Middle/Zoom Scan (5x5x7) (5x5x7)/Cube 0: Measurement grid: dx=8mm, dy=8mm, dz=5mm

Reference Value = 5.49 V/m; Power Drift = -0.075 dB

Peak SAR (extrapolated) = 0.756 W/kg

SAR(1 g) = 0.554 mW/g; SAR(10 g) = 0.403 mW/g

Maximum value of SAR (measured) = 0.591 mW/g

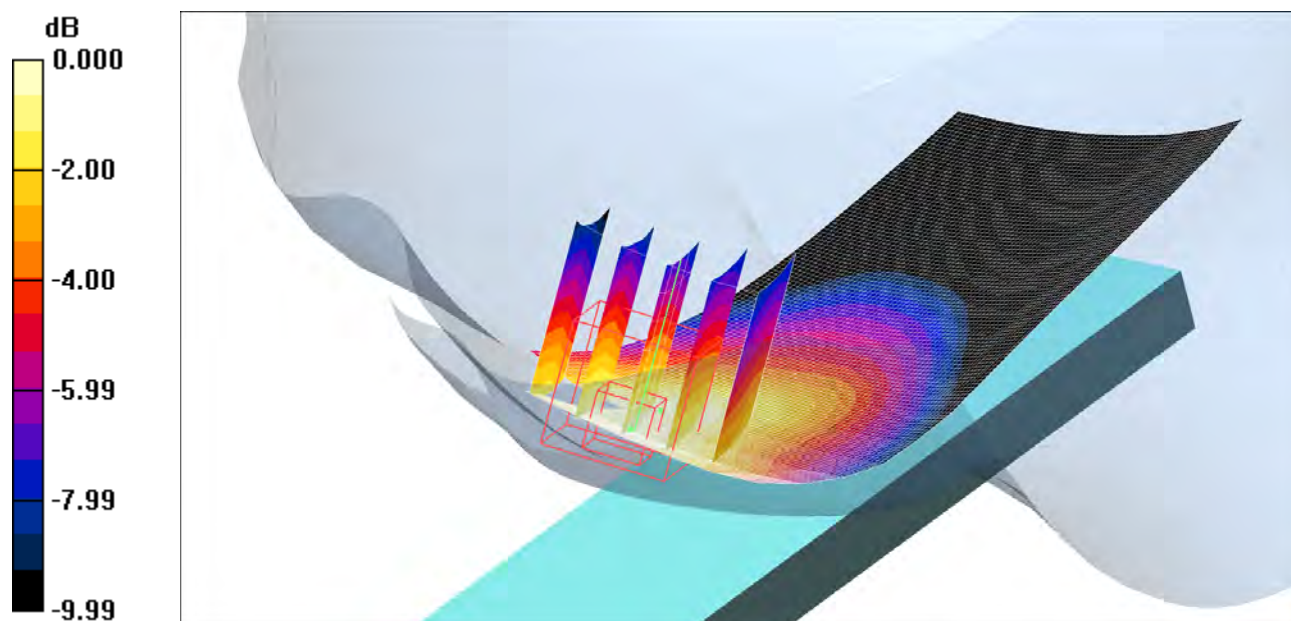

0 dB = 0.591mW/g



Accredited by the Swiss Federal Office of Metrology and Accreditation
The Swiss Accreditation Service is one of the signatories to the EA
Multilateral Agreement for the recognition of calibration certificates

Accreditation No.: **SCS 108**

Client **Ericsson UK**

Certificate No: **D1900V2-539_Dec06**

CALIBRATION CERTIFICATE

Object **D1900V2 - SN: 539**

Calibration procedure(s) **QA CAL-05 v6
Calibration procedure for dipole validation kits**

Calibration date: **December 12, 2006**

Condition of the calibrated item **In Tolerance**

This calibration certificate documents the traceability to national standards, which realize the physical units of measurements (SI).
The measurements and the uncertainties with confidence probability are given on the following pages and are part of the certificate.

All calibrations have been conducted in the closed laboratory facility: environment temperature (22 ± 3)°C and humidity < 70%.

Calibration Equipment used (M&TE critical for calibration)

Primary Standards	ID #	Cal Date (Calibrated by, Certificate No.)	Scheduled Calibration
Power meter EPM-442A	GB37480704	03-Oct-06 (METAS, No. 217-00608)	Oct-07
Power sensor HP 8481A	US37292783	03-Oct-06 (METAS, No. 217-00608)	Oct-07
Reference 20 dB Attenuator	SN: 5086 (20g)	10-Aug-06 (METAS, No 217-00591)	Aug-07
Reference 10 dB Attenuator	SN: 5047.2 (10r)	10-Aug-06 (METAS, No 217-00591)	Aug-07
Reference Probe ET3DV6	SN: 1507	19-Oct-06 (SPEAG, No. ET3-1507_Oct06)	Oct-07
Reference Probe ES3DV3	SN: 3025	19-Oct-06 (SPEAG, No. ES3-3025_Oct06)	Oct-07
DAE4	SN: 601	15-Dec-05 (SPEAG, No. DAE4-601_Dec05)	Dec-06
Secondary Standards	ID #	Check Date (in house)	Scheduled Check
Power sensor HP 8481A	MY41092317	18-Oct-02 (SPEAG, in house check Oct-05)	In house check: Oct-07
RF generator Agilent E4421B	MY41000675	11-May-05 (SPEAG, in house check Nov-05)	In house check: Nov-07
Network Analyzer HP 8753E	US37390585 S4206	18-Oct-01 (SPEAG, in house check Oct-06)	In house check: Oct-07

Calibrated by: **Mike Mell** **Laboratory Technician** *M. Mell*

Approved by: **Katja Pokovic** **Technical Manager** *Katja Pokovic*

Issued: December 13, 2006

This calibration certificate shall not be reproduced except in full without written approval of the laboratory.



Accredited by the Swiss Federal Office of Metrology and Accreditation
The Swiss Accreditation Service is one of the signatories to the EA
Multilateral Agreement for the recognition of calibration certificates

Accreditation No.: **SCS 108**

Glossary:

TSL	tissue simulating liquid
ConvF	sensitivity in TSL / NORM x,y,z
N/A	not applicable or not measured

Calibration is Performed According to the Following Standards:

- IEEE Std 1528-2003, "IEEE Recommended Practice for Determining the Peak Spatial-Averaged Specific Absorption Rate (SAR) in the Human Head from Wireless Communications Devices: Measurement Techniques", December 2003
- CENELEC EN 50361, "Basic standard for the measurement of Specific Absorption Rate related to human exposure to electromagnetic fields from mobile phones (300 MHz - 3 GHz), July 2001
- Federal Communications Commission Office of Engineering & Technology (FCC OET), "Evaluating Compliance with FCC Guidelines for Human Exposure to Radiofrequency Electromagnetic Fields; Additional Information for Evaluating Compliance of Mobile and Portable Devices with FCC Limits for Human Exposure to Radiofrequency Emissions", Supplement C (Edition 01-01) to Bulletin 65

Additional Documentation:

- DASY4 System Handbook

Methods Applied and Interpretation of Parameters:

- Measurement Conditions:** Further details are available from the Validation Report at the end of the certificate. All figures stated in the certificate are valid at the frequency indicated.
- Antenna Parameters with TSL:** The dipole is mounted with the spacer to position its feed point exactly below the center marking of the flat phantom section, with the arms oriented parallel to the body axis.
- Feed Point Impedance and Return Loss:** These parameters are measured with the dipole positioned under the liquid filled phantom. The impedance stated is transformed from the measurement at the SMA connector to the feed point. The Return Loss ensures low reflected power. No uncertainty required.
- Electrical Delay:** One-way delay between the SMA connector and the antenna feed point. No uncertainty required.
- SAR measured:** SAR measured at the stated antenna input power.
- SAR normalized:** SAR as measured, normalized to an input power of 1 W at the antenna connector.
- SAR for nominal TSL parameters:** The measured TSL parameters are used to calculate the nominal SAR result.

Measurement Conditions

DASY system configuration, as far as not given on page 1.

DASY Version	DASY4	V4.7
Extrapolation	Advanced Extrapolation	
Phantom	Modular Flat Phantom V5.0	
Distance Dipole Center - TSL	10 mm	with Spacer
Area Scan Resolution	dx, dy = 15 mm	
Zoom Scan Resolution	dx, dy, dz = 5 mm	
Frequency	1900 MHz \pm 1 MHz	

Head TSL parameters

The following parameters and calculations were applied.

	Temperature	Permittivity	Conductivity
Nominal Head TSL parameters	22.0 °C	40.0	1.40 mho/m
Measured Head TSL parameters	(22.0 \pm 0.2) °C	38.4 \pm 6 %	1.40 mho/m \pm 6 %
Head TSL temperature during test	(21.2 \pm 0.2) °C	---	---

SAR result with Head TSL

SAR averaged over 1 cm³ (1 g) of Head TSL	condition	
SAR measured	250 mW input power	9.18 mW / g
SAR normalized	normalized to 1W	36.7 mW / g
SAR for nominal Head TSL parameters ¹	normalized to 1W	35.9 mW / g \pm 17.0 % (k=2)

SAR averaged over 10 cm³ (10 g) of Head TSL	Condition	
SAR measured	250 mW input power	4.85 mW / g
SAR normalized	normalized to 1W	19.4 mW / g
SAR for nominal Head TSL parameters ¹	normalized to 1W	19.1 mW / g \pm 16.5 % (k=2)

¹ Correction to nominal TSL parameters according to d), chapter "SAR Sensitivities"

Body TSL parameters

The following parameters and calculations were applied.

	Temperature	Permittivity	Conductivity
Nominal Body TSL parameters	22.0 °C	53.3	1.52 mho/m
Measured Body TSL parameters	(22.0 ± 0.2) °C	51.8 ± 6 %	1.54 mho/m ± 6 %
Body TSL temperature during test	(21.6 ± 0.2) °C	—	—

SAR result with Body TSL

SAR averaged over 1 cm ³ (1 g) of Body TSL	Condition	
SAR measured	250 mW input power	9.49 mW / g
SAR normalized	normalized to 1W	38.0 mW / g
SAR for nominal Body TSL parameters ²	normalized to 1W	37.0 mW / g ± 17.0 % (k=2)

SAR averaged over 10 cm ³ (10 g) of Body TSL	condition	
SAR measured	250 mW input power	5.05 mW / g
SAR normalized	normalized to 1W	20.2 mW / g
SAR for nominal Body TSL parameters ²	normalized to 1W	19.8 mW / g ± 16.5 % (k=2)

² Correction to nominal TSL parameters according to d), chapter "SAR Sensitivities"

Appendix

Antenna Parameters with Head TSL

Impedance, transformed to feed point	54.1 Ω + 0.9 j Ω
Return Loss	- 27.9 dB

Antenna Parameters with Body TSL

Impedance, transformed to feed point	49.0 Ω + 2.7 j Ω
Return Loss	- 30.7 dB

General Antenna Parameters and Design

Electrical Delay (one direction)	1.200 ns
----------------------------------	----------

After long term use with 100W radiated power, only a slight warming of the dipole near the feedpoint can be measured.

The dipole is made of standard semirigid coaxial cable. The center conductor of the feeding line is directly connected to the second arm of the dipole. The antenna is therefore short-circuited for DC-signals.

No excessive force must be applied to the dipole arms, because they might bend or the soldered connections near the feedpoint may be damaged.

Additional EUT Data

Manufactured by	SPEAG
Manufactured on	July 26, 2001

DASY4 Validation Report for Head TSL

Date/Time: 11.12.2006 17:13:38

Test Laboratory: SPEAG, Zurich, Switzerland

DUT: Dipole 1900 MHz; Type: D1900V2; Serial: D1900V2 - SN:539

Communication System: CW; Frequency: 1900 MHz; Duty Cycle: 1:1

Medium: HSL U10 BB;

Medium parameters used: $f = 1900$ MHz; $\sigma = 1.4$ mho/m; $\epsilon_r = 38.4$; $\rho = 1000$ kg/m³

Phantom section: Flat Section

Measurement Standard: DASY4 (High Precision Assessment)

DASY4 Configuration:

- Probe: ET3DV6 - SN1507 (HF); ConvF(4.97, 4.97, 4.97); Calibrated: 19.10.2006
- Sensor-Surface: 4mm (Mechanical Surface Detection)
- Electronics: DAE4 Sn601; Calibrated: 15.12.2005
- Phantom: Flat Phantom 5.0 (front); Type: QD000P50AA; ;
- Measurement SW: DASY4, V4.7 Build 44; Postprocessing SW: SEMCAD, V1.8 Build 171

Pin = 250 mW; d = 10 mm/Area Scan (101x101x1):

Measurement grid: dx=10mm, dy=10mm

Maximum value of SAR (interpolated) = 10.3 mW/g

Pin = 250 mW; d = 10 mm/Zoom Scan (7x7x7)/Cube 0:

Measurement grid: dx=5mm, dy=5mm, dz=5mm

Reference Value = 86.4 V/m; Power Drift = 0.045 dB

Peak SAR (extrapolated) = 15.7 W/kg

SAR(1 g) = 9.18 mW/g; SAR(10 g) = 4.85 mW/g

Maximum value of SAR (measured) = 10.5 mW/g

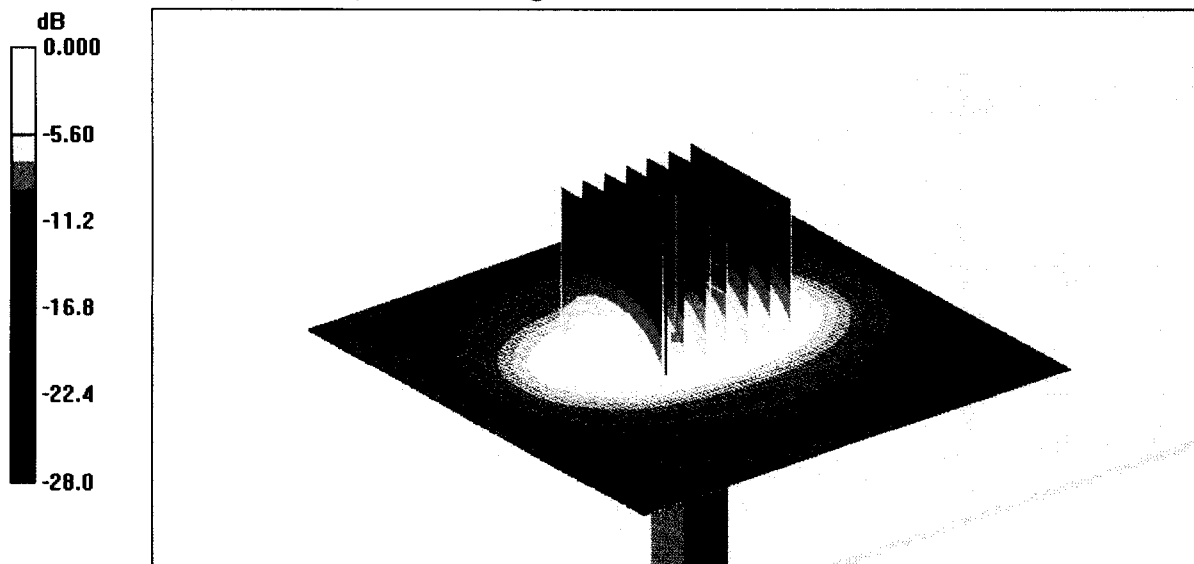

0 dB = 10.5mW/g

Impedance Measurement Plot for Head TSL

11 Dec 2006 12:34:44

CH1 S11 1 U FS 2: 54.098 Ω 0.8848 Ω 74.113 μH 1 900.000 000 MHz

*
Del
Cor

Avg
16

↑

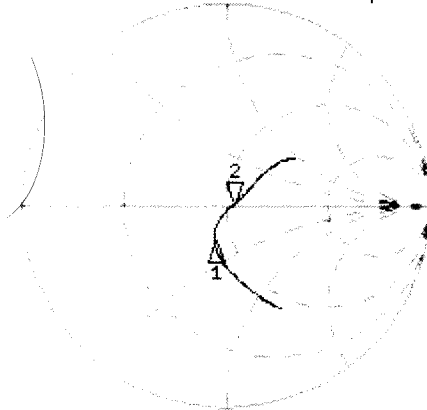

CH1 Markers

1: 42.035 Ω
-15.363 Ω
1.80000 GHz

CH2 S11 LOG 5 dB/REF -20 dB 2: -27.899 dB 1 900.000 000 MHz

Cor

Avg
16

↑

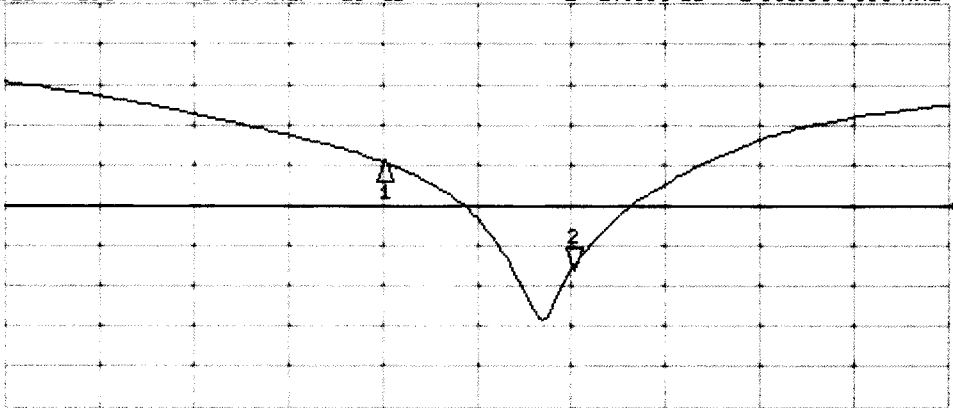

CH2 Markers

1: -14.635 dB
1.80000 GHz

START 1 600.000 000 MHz

STOP 2 100.000 000 MHz

DASY4 Validation Report for Body TSL

Date/Time: 12.12.2006 15:22:28

Test Laboratory: SPEAG, Zurich, Switzerland

DUT: Dipole 1900 MHz; Type: D1900V2; Serial: D1900V2 - SN:539

Communication System: CW; Frequency: 1900 MHz; Duty Cycle: 1:1

Medium: MSL U10 BB;

Medium parameters used: $f = 1900$ MHz; $\sigma = 1.54$ mho/m; $\epsilon_r = 51.8$; $\rho = 1000$ kg/m³

Phantom section: Flat Section

Measurement Standard: DASY4 (High Precision Assessment)

DASY4 Configuration:

- Probe: ET3DV6 - SN1507 (HF); ConvF(4.43, 4.43, 4.43); Calibrated: 19.10.2006
- Sensor-Surface: 4mm (Mechanical Surface Detection)
- Electronics: DAE4 Sn601; Calibrated: 15.12.2005
- Phantom: Flat Phantom 5.0 (front); Type: QD000P50AA; ;
- Measurement SW: DASY4, V4.7 Build 44; Postprocessing SW: SEMCAD, V1.8 Build 171

Pin = 250 mW; d = 10 mm/Zoom Scan (7x7x7)/Cube 0:

Measurement grid: dx=5mm, dy=5mm, dz=5mm

Reference Value = 89.4 V/m; Power Drift = -0.001 dB

Peak SAR (extrapolated) = 15.8 W/kg

SAR(1 g) = 9.49 mW/g; SAR(10 g) = 5.05 mW/g

Maximum value of SAR (measured) = 10.5 mW/g

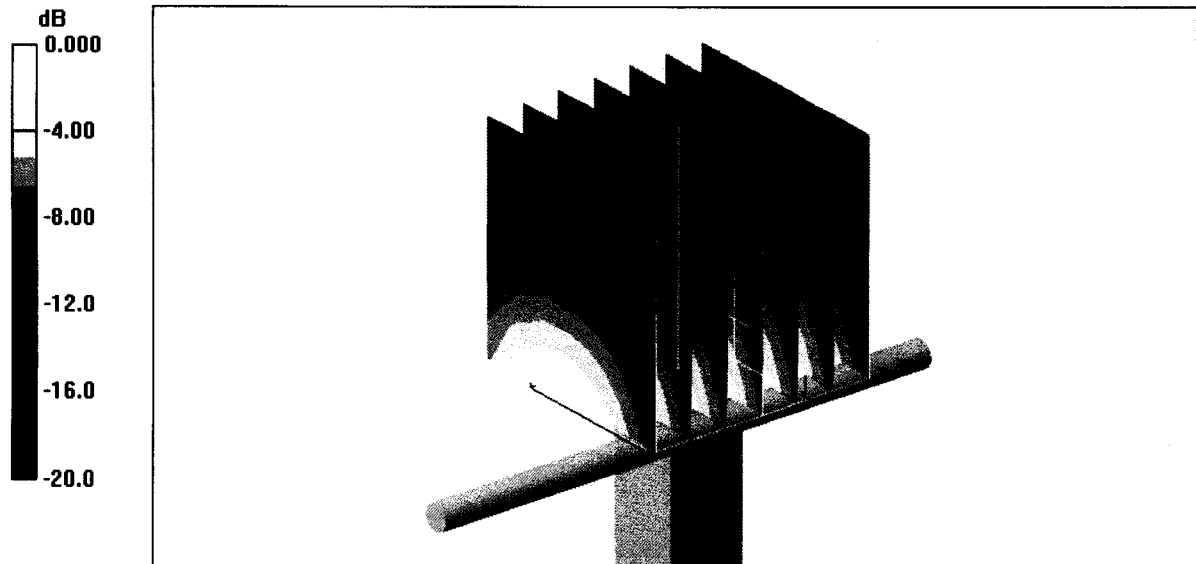

Impedance Measurement Plot for Body TSL

12 Dec 2006 11:17:34

[CH1] S11 1 U FS 1: 48.984 Ω 2.6953 Ω 225.77 pF 1 900.000 000 MHz

*
Del
Cor
Avg
16
↑

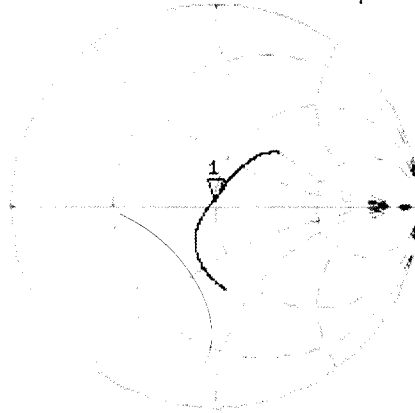

CH2 S11 LOG 3 dB/REF -20 dB 1:-30.733 dB 1 900.000 000 MHz

Cor
Avg
16
↑

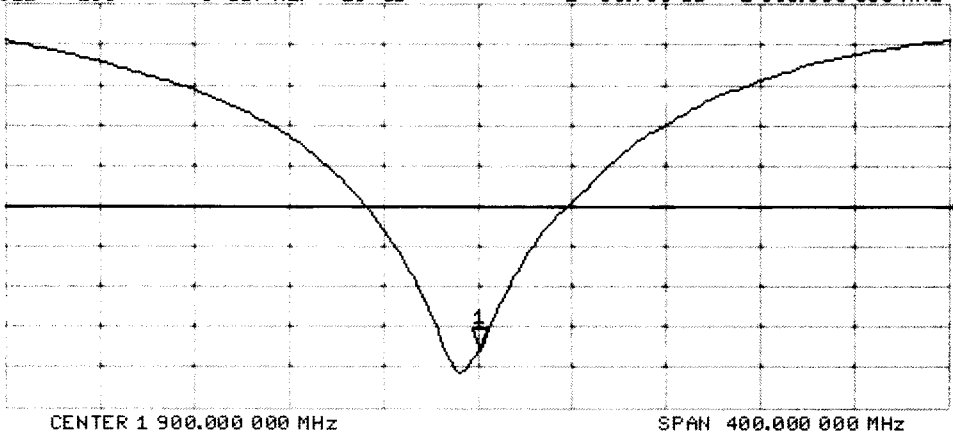



Accredited by the Swiss Federal Office of Metrology and Accreditation
The Swiss Accreditation Service is one of the signatories to the EA
Multilateral Agreement for the recognition of calibration certificates

Accreditation No.: **SCS 108**

Client **Ericsson UK**

Certificate No: **D835V2-442_Dec06**

CALIBRATION CERTIFICATE

Object **D835V2 - SN: 442**

Calibration procedure(s) **QA CAL-05.v6
Calibration procedure for dipole validation kits**

Calibration date: **December 06, 2006**

Condition of the calibrated item **In Tolerance**

This calibration certificate documents the traceability to national standards, which realize the physical units of measurements (SI).
The measurements and the uncertainties with confidence probability are given on the following pages and are part of the certificate.

All calibrations have been conducted in the closed laboratory facility: environment temperature (22 ± 3)°C and humidity < 70%.

Calibration Equipment used (M&TE critical for calibration)

Primary Standards	ID #	Cal Date (Calibrated by, Certificate No.)	Scheduled Calibration
Power meter EPM-442A	GB37480704	03-Oct-06 (METAS, No. 217-00608)	Oct-07
Power sensor HP 8481A	US37292783	03-Oct-06 (METAS, No. 217-00608)	Oct-07
Reference 20 dB Attenuator	SN: 5086 (20g)	10-Aug-06 (METAS, No 217-00591)	Aug-07
Reference 10 dB Attenuator	SN: 5047.2 (10r)	10-Aug-06 (METAS, No 217-00591)	Aug-07
Reference Probe ET3DV6 (HF)	SN 1507	19-Oct-06 (SPEAG, No. ET3-1507_Oct06)	Oct-07
DAE4	SN 601	15-Dec-05 (SPEAG, No. DAE4-601_Dec05)	Dec-06
Secondary Standards	ID #	Check Date (in house)	Scheduled Check
Power sensor HP 8481A	MY41092317	18-Oct-02 (SPEAG, in house check Oct-05)	In house check: Oct-07
RF generator Agilent E4421B	MY41000675	11-May-05 (SPEAG, in house check Nov-05)	In house check: Nov-07
Network Analyzer HP 8753E	US37390585 S4206	18-Oct-01 (SPEAG, in house check Oct-06)	In house check: Oct-07

	Name	Function	Signature
Calibrated by:	Claudio Leubler	Laboratory Technician	
Approved by:	Katja Pokovic	Technical Manager	

Issued: December 8, 2006

This calibration certificate shall not be reproduced except in full without written approval of the laboratory.



Accredited by the Swiss Federal Office of Metrology and Accreditation
The Swiss Accreditation Service is one of the signatories to the EA
Multilateral Agreement for the recognition of calibration certificates

Accreditation No.: **SCS 108**

Glossary:

TSL	tissue simulating liquid
ConvF	sensitivity in TSL / NORM x,y,z
N/A	not applicable or not measured

Calibration is Performed According to the Following Standards:

- IEEE Std 1528-2003, "IEEE Recommended Practice for Determining the Peak Spatial-Averaged Specific Absorption Rate (SAR) in the Human Head from Wireless Communications Devices: Measurement Techniques", December 2003
- CENELEC EN 50361, "Basic standard for the measurement of Specific Absorption Rate related to human exposure to electromagnetic fields from mobile phones (300 MHz - 3 GHz), July 2001
- Federal Communications Commission Office of Engineering & Technology (FCC OET), "Evaluating Compliance with FCC Guidelines for Human Exposure to Radiofrequency Electromagnetic Fields; Additional Information for Evaluating Compliance of Mobile and Portable Devices with FCC Limits for Human Exposure to Radiofrequency Emissions", Supplement C (Edition 01-01) to Bulletin 65

Additional Documentation:

- DASY4 System Handbook

Methods Applied and Interpretation of Parameters:

- Measurement Conditions:** Further details are available from the Validation Report at the end of the certificate. All figures stated in the certificate are valid at the frequency indicated.
- Antenna Parameters with TSL:** The dipole is mounted with the spacer to position its feed point exactly below the center marking of the flat phantom section, with the arms oriented parallel to the body axis.
- Feed Point Impedance and Return Loss:** These parameters are measured with the dipole positioned under the liquid filled phantom. The impedance stated is transformed from the measurement at the SMA connector to the feed point. The Return Loss ensures low reflected power. No uncertainty required.
- Electrical Delay:** One-way delay between the SMA connector and the antenna feed point. No uncertainty required.
- SAR measured:** SAR measured at the stated antenna input power.
- SAR normalized:** SAR as measured, normalized to an input power of 1 W at the antenna connector.
- SAR for nominal TSL parameters:** The measured TSL parameters are used to calculate the nominal SAR result.

Measurement Conditions

DASY system configuration, as far as not given on page 1.

DASY Version	DASY4	V4.7
Extrapolation	Advanced Extrapolation	
Phantom	Modular Flat Phantom V4.9	
Distance Dipole Center - TSL	15 mm	with Spacer
Zoom Scan Resolution	dx, dy, dz = 5 mm	
Frequency	835 MHz ± 1 MHz	

Head TSL parameters

The following parameters and calculations were applied.

	Temperature	Permittivity	Conductivity
Nominal Head TSL parameters	22.0 °C	41.5	0.90 mho/m
Measured Head TSL parameters	(22.0 ± 0.2) °C	41.7 ± 6 %	0.90 mho/m ± 6 %
Head TSL temperature during test	(22.8 ± 0.2) °C	---	---

SAR result with Head TSL

SAR averaged over 1 cm³ (1 g) of Head TSL	Condition	
SAR measured	250 mW input power	2.35 mW / g
SAR normalized	normalized to 1W	9.40 mW / g
SAR for nominal Head TSL parameters ¹	normalized to 1W	9.43 mW / g ± 17.0 % (k=2)

SAR averaged over 10 cm³ (10 g) of Head TSL	condition	
SAR measured	250 mW input power	1.54 mW / g
SAR normalized	normalized to 1W	6.16 mW / g
SAR for nominal Head TSL parameters ¹	normalized to 1W	6.17 mW / g ± 16.5 % (k=2)

¹ Correction to nominal TSL parameters according to d), chapter "SAR Sensitivities"

Body TSL parameters

The following parameters and calculations were applied.

	Temperature	Permittivity	Conductivity
Nominal Body TSL parameters	22.0 °C	55.2	0.97 mho/m
Measured Body TSL parameters	(22.0 ± 0.2) °C	54.1 ± 6 %	1.00 mho/m ± 6 %
Body TSL temperature during test	(22.0 ± 0.2) °C	—	—

SAR result with Body TSL

SAR averaged over 1 cm ³ (1 g) of Body TSL	condition	
SAR measured	250 mW input power	2.51 mW / g
SAR normalized	normalized to 1W	10.0 mW / g
SAR for nominal Body TSL parameters ²	normalized to 1W	9.70 mW / g ± 17.0 % (k=2)

SAR averaged over 10 cm ³ (10 g) of Body TSL	condition	
SAR measured	250 mW input power	1.67 mW / g
SAR normalized	normalized to 1W	6.68 mW / g
SAR for nominal Body TSL parameters ²	normalized to 1W	6.51 mW / g ± 16.5 % (k=2)

² Correction to nominal TSL parameters according to d), chapter "SAR Sensitivities"

Appendix

Antenna Parameters with Head TSL

Impedance, transformed to feed point	50.3 Ω - 7.5 j Ω
Return Loss	- 22.5 dB

Antenna Parameters with Body TSL

Impedance, transformed to feed point	46.2 Ω - 9.7 j Ω
Return Loss	- 19.4 dB

General Antenna Parameters and Design

Electrical Delay (one direction)	1.390 ns
----------------------------------	----------

After long term use with 100W radiated power, only a slight warming of the dipole near the feedpoint can be measured.

The dipole is made of standard semirigid coaxial cable. The center conductor of the feeding line is directly connected to the second arm of the dipole. The antenna is therefore short-circuited for DC-signals.

No excessive force must be applied to the dipole arms, because they might bend or the soldered connections near the feedpoint may be damaged.

Additional EUT Data

Manufactured by	SPEAG
Manufactured on	July 26, 2001

DASY4 Validation Report for Head TSL

Date/Time: 05.12.2006 12:25:28

Test Laboratory: SPEAG, Zurich, Switzerland

DUT: Dipole 835 MHz; Type: D835V2; Serial: D835V2 - SN: 442

Communication System: CW; Frequency: 835 MHz; Duty Cycle: 1:1

Medium: HSL 900 MHz;

Medium parameters used: $f = 835 \text{ MHz}$; $\sigma = 0.902 \text{ mho/m}$; $\epsilon_r = 42$; $\rho = 1000 \text{ kg/m}^3$

Phantom section: Flat Section

Measurement Standard: DASY4 (High Precision Assessment)

DASY4 Configuration:

- Probe: ET3DV6 - SN1507 (HF); ConvF(6.09, 6.09, 6.09); Calibrated: 19.10.2006
- Sensor-Surface: 4mm (Mechanical Surface Detection)
- Electronics: DAE4 Sn601; Calibrated: 15.12.2005
- Phantom: Flat Phantom 4.9L; Type: QD000P49AA; ;
- Measurement SW: DASY4, V4.7 Build 46; Postprocessing SW: SEMCAD, V1.8 Build 171

Pin = 250 mW; d = 15 mm/Zoom Scan (7x7x7)/Cube 0:

Measurement grid: $dx=5\text{mm}$, $dy=5\text{mm}$, $dz=5\text{mm}$

Reference Value = 55.5 V/m; Power Drift = -0.017 dB

Peak SAR (extrapolated) = 3.40 W/kg

SAR(1 g) = 2.35 mW/g; SAR(10 g) = 1.54 mW/g

Maximum value of SAR (measured) = 2.55 mW/g

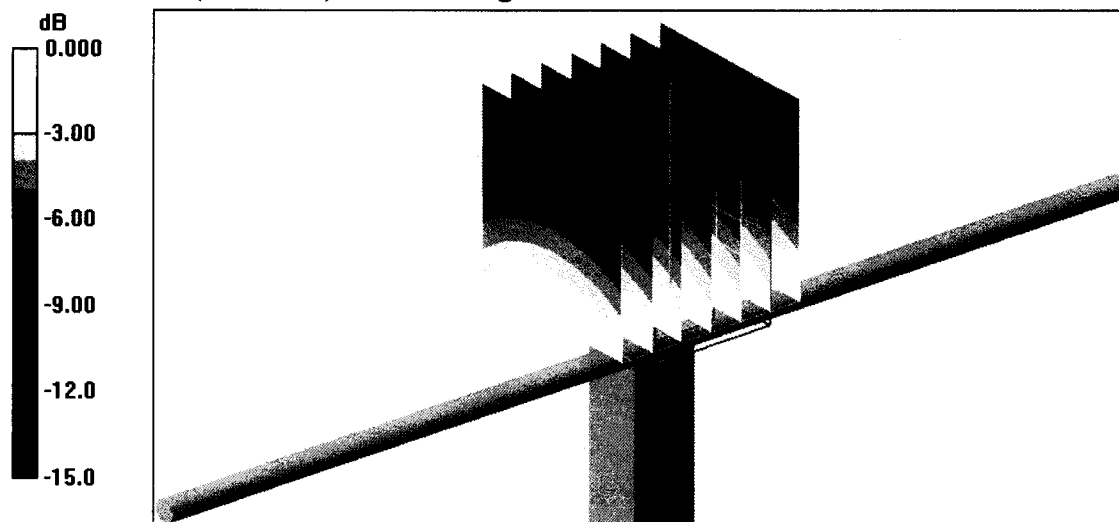

0 dB = 2.55mW/g

Impedance Measurement Plot for Head TSL

5 Dec 2006 12:03:21

CH1 S11 1 U FS 1: 50.336 Ω -7.5410 Ω 25.276 pF 835.000 000 MHz

*
Del
CA

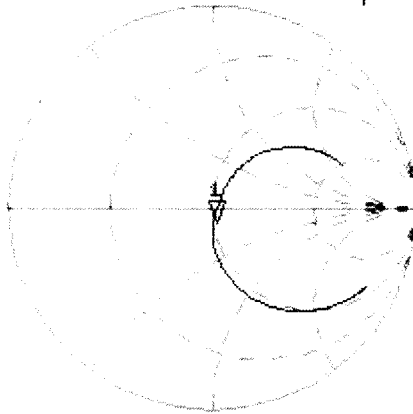

Avg
16
↑

CH2 S11 LOG 5 dB/REF -20 dB 1:-22.494 dB 835.000 000 MHz

CA
Avg
16
↑

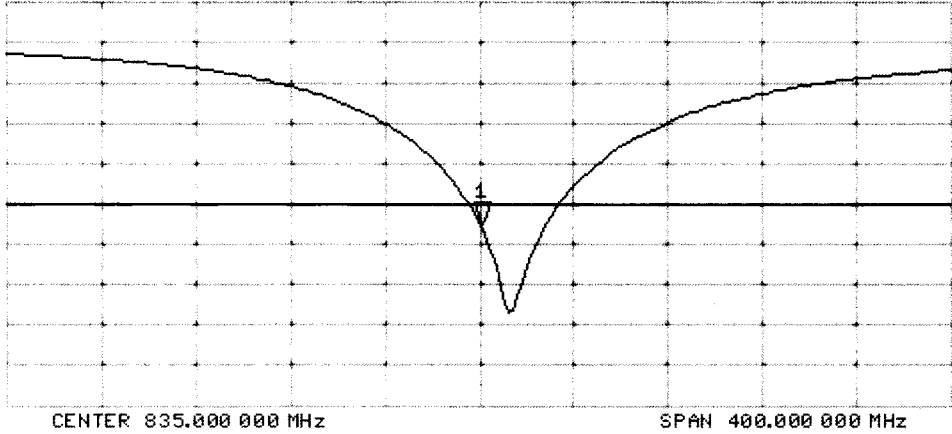

DASY4 Validation Report for Body TSL

Date/Time: 06.12.2006 13:07:13

Test Laboratory: SPEAG, Zurich, Switzerland

DUT: Dipole 835 MHz; Type: D835V2; Serial: D835V2 - SN:442

Communication System: CW; Frequency: 835 MHz; Duty Cycle: 1:1

Medium: MSL900;

Medium parameters used: $f = 835 \text{ MHz}$; $\sigma = 1 \text{ mho/m}$; $\epsilon_r = 54.1$; $\rho = 1000 \text{ kg/m}^3$

Phantom section: Flat Section

Measurement Standard: DASY4 (High Precision Assessment)

DASY4 Configuration:

- Probe: ET3DV6 - SN1507 (HF); ConvF(5.75, 5.75, 5.75); Calibrated: 19.10.2006
- Sensor-Surface: 4mm (Mechanical Surface Detection)
- Electronics: DAE4 Sn601; Calibrated: 15.12.2005
- Phantom: Flat Phantom 4.9L; Type: QD000P49AA; ;
- Measurement SW: DASY4, V4.7 Build 46; Postprocessing SW: SEMCAD, V1.8 Build 171

Pin = 250 mW; d = 15 mm/Zoom Scan (7x7x7)/Cube 0:

Measurement grid: dx=5mm, dy=5mm, dz=5mm

Reference Value = 54.7 V/m; Power Drift = -0.002 dB

Peak SAR (extrapolated) = 3.49 W/kg

SAR(1 g) = 2.51 mW/g; SAR(10 g) = 1.67 mW/g

Maximum value of SAR (measured) = 2.72 mW/g

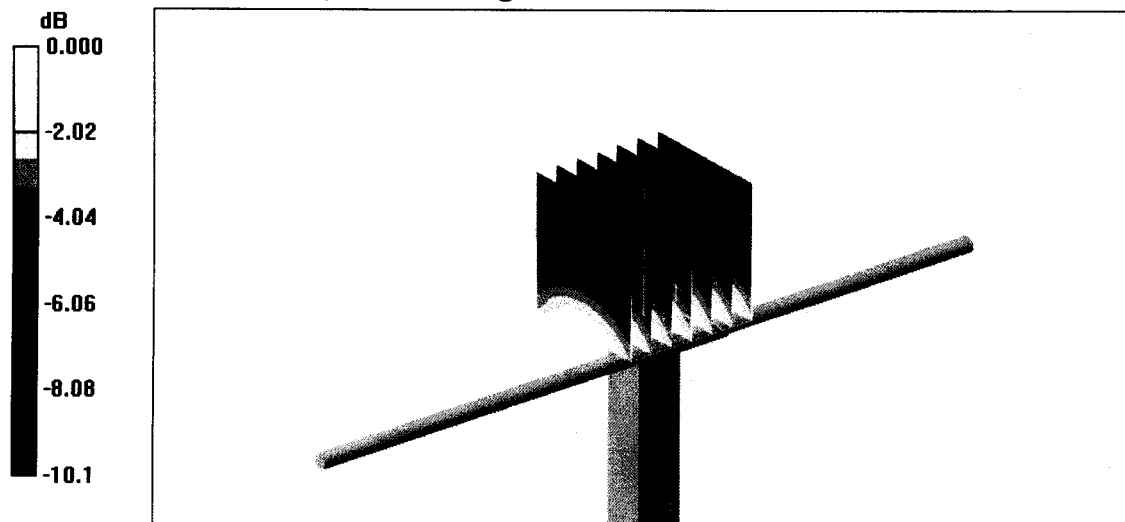

0 dB = 2.72mW/g

Impedance Measurement Plot for Body TSL

6 Dec 2006 10:32:17

CH1 S11 1 U FS 1: 46.182 Ω -9.6504 Ω 19.751 pF 835.000 000 MHz

*
Del
Cor

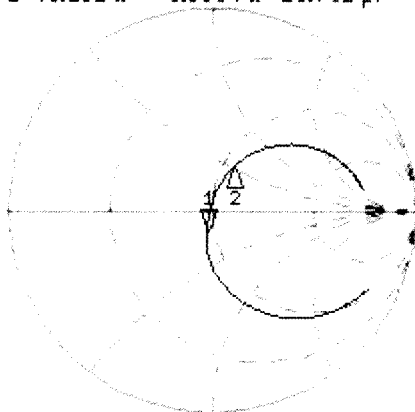

CH1 Markers
2: 55.250 Ω
25.500 Ω
900.000 MHz

Avg
16

↑

CH2 S11 LOG 5 dB/REF -20 dB 1: -19.385 dB 835.000 000 MHz

Cor

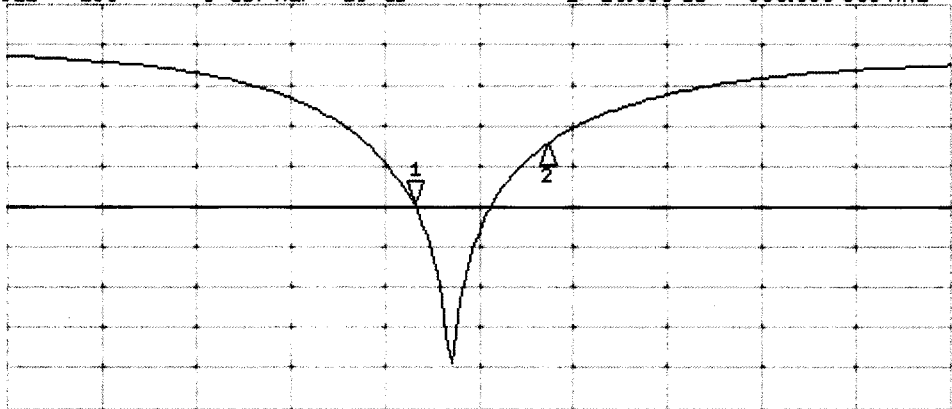

CH2 Markers
2: -12.379 dB
900.000 MHz

Avg
16

↑

START 635.000 000 MHz

STOP 1 100.000 000 MHz



Accredited by the Swiss Accreditation Service (SAS)
The Swiss Accreditation Service is one of the signatories to the EA
Multilateral Agreement for the recognition of calibration certificates

Accreditation No.: **SCS 108**

Client **Sony Electronics UK**

Certificate No: **DAE3-448_Nov07**

CALIBRATION CERTIFICATE

Object **DAE3 - SD 000 D03 AE - SN: 448**

Calibration procedure(s) **QA CAL-06.v12
Calibration procedure for the data acquisition electronics (DAE)**

Calibration date: **November 15, 2007**

Condition of the calibrated item **In Tolerance**

This calibration certificate documents the traceability to national standards, which realize the physical units of measurements (SI).
The measurements and the uncertainties with confidence probability are given on the following pages and are part of the certificate.

All calibrations have been conducted in the closed laboratory facility: environment temperature (22 ± 3)°C and humidity < 70%.

Calibration Equipment used (M&TE critical for calibration)

Primary Standards	ID #	Cal Date (Calibrated by, Certificate No.)	Scheduled Calibration
Fluke Process Calibrator Type 702	SN: 6295803	04-Oct-07 (Elcal AG, No: 6467)	Oct-08
Keithley Multimeter Type 2001	SN: 0810278	03-Oct-07 (Elcal AG, No: 6465)	Oct-08
Secondary Standards	ID #	Check Date (in house)	Scheduled Check
Calibrator Box V1.1	SE UMS 006 AB 1004	25-Jun-07 (SPEAG, in house check)	In house check Jun-08

Calibrated by: **Name** **Dominique Steffen** **Function** **Technician** **Signature**

Approved by: **Fin Bornholt** **R&D Director**

Issued: November 15, 2007

This calibration certificate shall not be reproduced except in full without written approval of the laboratory.



Glossary

DAE	data acquisition electronics
Connector angle	information used in DASY system to align probe sensor X to the robot coordinate system.

Methods Applied and Interpretation of Parameters

- **DC Voltage Measurement:** Calibration Factor assessed for use in DASY system by comparison with a calibrated instrument traceable to national standards. The figure given corresponds to the full scale range of the voltmeter in the respective range.
- **Connector angle:** The angle of the connector is assessed measuring the angle mechanically by a tool inserted. Uncertainty is not required.
- The following parameters contain technical information as a result from the performance test and require no uncertainty.
- **DC Voltage Measurement Linearity:** Verification of the Linearity at +10% and -10% of the nominal calibration voltage. Influence of offset voltage is included in this measurement.
- **Common mode sensitivity:** Influence of a positive or negative common mode voltage on the differential measurement.
- **Channel separation:** Influence of a voltage on the neighbor channels not subject to an input voltage.
- **AD Converter Values with inputs shorted:** Values on the internal AD converter corresponding to zero input voltage
- **Input Offset Measurement:** Output voltage and statistical results over a large number of zero voltage measurements.
- **Input Offset Current:** Typical value for information; Maximum channel input offset current, not considering the input resistance.
- **Input resistance:** DAE input resistance at the connector, during internal auto-zeroing and during measurement.
- **Low Battery Alarm Voltage:** Typical value for information. Below this voltage, a battery alarm signal is generated.
- **Power consumption:** Typical value for information. Supply currents in various operating modes.

DC Voltage Measurement

A/D - Converter Resolution nominal

High Range: 1LSB = 6.1 μ V, full range = -100...+300 mV

Low Range: 1LSB = 61nV, full range = -1.....+3mV

DASY measurement parameters: Auto Zero Time: 3 sec; Measuring time: 3 sec

Calibration Factors	X	Y	Z
High Range	403.816 \pm 0.1% (k=2)	404.070 \pm 0.1% (k=2)	403.834 \pm 0.1% (k=2)
Low Range	3.95937 \pm 0.7% (k=2)	3.96143 \pm 0.7% (k=2)	3.93067 \pm 0.7% (k=2)

Connector Angle

Connector Angle to be used in DASY system	277 $^{\circ}$ \pm 1 $^{\circ}$
---	-----------------------------------

Appendix

1. DC Voltage Linearity

High Range	Input (μV)	Reading (μV)	Error (%)
Channel X + Input	200000	200000.1	0.00
Channel X + Input	20000	20008.04	0.04
Channel X - Input	20000	-20002.96	0.01
Channel Y + Input	200000	199999.5	0.00
Channel Y + Input	20000	20005.57	0.03
Channel Y - Input	20000	-20005.68	0.03
Channel Z + Input	200000	199999.3	0.00
Channel Z + Input	20000	20006.62	0.03
Channel Z - Input	20000	-20004.64	0.02

Low Range	Input (μV)	Reading (μV)	Error (%)
Channel X + Input	2000	1999.9	0.00
Channel X + Input	200	201.18	0.59
Channel X - Input	200	-199.65	-0.17
Channel Y + Input	2000	2000	0.00
Channel Y + Input	200	199.43	-0.28
Channel Y - Input	200	-200.60	0.30
Channel Z + Input	2000	2000.1	0.00
Channel Z + Input	200	199.20	-0.40
Channel Z - Input	200	-200.60	0.30

2. Common mode sensitivity

DASY measurement parameters: Auto Zero Time: 3 sec; Measuring time: 3 sec

	Common mode Input Voltage (mV)	High Range Average Reading (μV)	Low Range Average Reading (μV)
Channel X	200	10.80	9.16
	- 200	-8.06	-8.82
Channel Y	200	-9.03	-8.67
	- 200	7.38	7.30
Channel Z	200	11.34	10.22
	- 200	-11.97	-11.93

3. Channel separation

DASY measurement parameters: Auto Zero Time: 3 sec; Measuring time: 3 sec

	Input Voltage (mV)	Channel X (μV)	Channel Y (μV)	Channel Z (μV)
Channel X	200	-	1.80	0.18
Channel Y	200	0.22	-	3.40
Channel Z	200	-2.84	-0.85	-

4. AD-Converter Values with inputs shorted

DASY measurement parameters: Auto Zero Time: 3 sec; Measuring time: 3 sec

	High Range (LSB)	Low Range (LSB)
Channel X	16252	17093
Channel Y	16361	17876
Channel Z	16104	15739

5. Input Offset Measurement

DASY measurement parameters: Auto Zero Time: 3 sec; Measuring time: 3 sec

Input 10M Ω

	Average (μ V)	min. Offset (μ V)	max. Offset (μ V)	Std. Deviation (μ V)
Channel X	0.19	-1.33	1.54	0.41
Channel Y	-0.76	-2.61	0.61	0.29
Channel Z	-0.83	-2.27	0.40	0.38

6. Input Offset Current

Nominal Input circuitry offset current on all channels: <25fA

7. Input Resistance

	Zeroing (MOhm)	Measuring (MOhm)
Channel X	0.2000	199.7
Channel Y	0.1999	200.9
Channel Z	0.1999	201.1

8. Low Battery Alarm Voltage (verified during pre test)

Typical values	Alarm Level (VDC)
Supply (+ Vcc)	+7.9
Supply (- Vcc)	-7.6

9. Power Consumption (verified during pre test)

Typical values	Switched off (mA)	Stand by (mA)	Transmitting (mA)
Supply (+ Vcc)	+0.0	+6	+14
Supply (- Vcc)	-0.01	-8	-9



Accredited by the Swiss Accreditation Service (SAS)
The Swiss Accreditation Service is one of the signatories to the EA
Multilateral Agreement for the recognition of calibration certificates

Accreditation No.: **SCS 108**

Client

Sony Electronics Inc.

[Redacted]

CALIBRATION CERTIFICATE

Object: **ET3DV6 - SN:1610**

Calibration procedure(s): **GR CAL-01-V6**
Calibration procedure for Frequency Standard: Frequency Standard

Calibration date: **November 14, 2007**

Condition of the calibrated item: **In Tolerance**

This calibration certificate documents the traceability to national standards, which realize the physical units of measurements (SI).
The measurements and the uncertainties with confidence probability are given on the following pages and are part of the certificate.

All calibrations have been conducted in the closed laboratory facility: environment temperature (22 ± 3)°C and humidity < 70%.

Calibration Equipment used (M&TE critical for calibration)

Primary Standards	ID #	Cal Date (Calibrated by, Certificate No.)	Scheduled Calibration
Power meter E4419B	GB41293874	29-Mar-07 (METAS, No. 217-00670)	Mar-08
Power sensor E4412A	MY41495277	29-Mar-07 (METAS, No. 217-00670)	Mar-08
Power sensor E4412A	MY41498087	29-Mar-07 (METAS, No. 217-00670)	Mar-08
Reference 3 dB Attenuator	SN: S5054 (3c)	8-Aug-07 (METAS, No. 217-00719)	Aug-08
Reference 20 dB Attenuator	SN: S5086 (20b)	29-Mar-07 (METAS, No. 217-00671)	Mar-08
Reference 30 dB Attenuator	SN: S5129 (30b)	8-Aug-07 (METAS, No. 217-00720)	Aug-08
Reference Probe ES3DV2	SN: 3013	4-Jan-07 (SPEAG, No. ES3-3013_Jan07)	Jan-08
DAE4	SN: 654	20-Apr-07 (SPEAG, No. DAE4-654_Apr07)	Apr-08

Secondary Standards	ID #	Check Date (in house)	Scheduled Check
RF generator HP 8648C	US3642U01700	4-Aug-99 (SPEAG, in house check Oct-07)	In house check: Oct-09
Network Analyzer HP 8753E	US37390585	18-Oct-01 (SPEAG, in house check Oct-07)	In house check: Oct-08

	Name	Function	Signature
Calibrated by:	Kolja Fritsch	Technical Manager	[Signature]
Approved by:	Markus Kuster	Quality Manager	[Signature]

Issued: November 14, 2007

This calibration certificate shall not be reproduced except in full without written approval of the laboratory.



Accredited by the Swiss Accreditation Service (SAS)

The Swiss Accreditation Service is one of the signatories to the EA
Multilateral Agreement for the recognition of calibration certificates

Accreditation No.: **SCS 108**

Glossary:

TSL	tissue simulating liquid
NORM _{x,y,z}	sensitivity in free space
ConF	sensitivity in TSL / NORM _{x,y,z}
DCP	diode compression point
Polarization φ	φ rotation around probe axis
Polarization ϑ	ϑ rotation around an axis that is in the plane normal to probe axis (at measurement center), i.e., $\vartheta = 0$ is normal to probe axis

Calibration is Performed According to the Following Standards:

- IEEE Std 1528-2003, "IEEE Recommended Practice for Determining the Peak Spatial-Averaged Specific Absorption Rate (SAR) in the Human Head from Wireless Communications Devices: Measurement Techniques", December 2003
- IEC 62209-1, "Procedure to measure the Specific Absorption Rate (SAR) for hand-held devices used in close proximity to the ear (frequency range of 300 MHz to 3 GHz)", February 2005

Methods Applied and Interpretation of Parameters:

- NORM_{x,y,z}**: Assessed for E-field polarization $\vartheta = 0$ ($f \leq 900$ MHz in TEM-cell; $f > 1800$ MHz: R22 waveguide). NORM_{x,y,z} are only intermediate values, i.e., the uncertainties of NORM_{x,y,z} does not effect the E²-field uncertainty inside TSL (see below *ConvF*).
- NORM(f)_{x,y,z} = NORM_{x,y,z} * frequency_response** (see Frequency Response Chart). This linearization is implemented in DASY4 software versions later than 4.2. The uncertainty of the frequency response is included in the stated uncertainty of *ConvF*.
- DCP_{x,y,z}**: DCP are numerical linearization parameters assessed based on the data of power sweep (no uncertainty required). DCP does not depend on frequency nor media.
- ConvF and Boundary Effect Parameters**: Assessed in flat phantom using E-field (or Temperature Transfer Standard for $f \leq 800$ MHz) and inside waveguide using analytical field distributions based on power measurements for $f > 800$ MHz. The same setups are used for assessment of the parameters applied for boundary compensation (alpha, depth) of which typical uncertainty values are given. These parameters are used in DASY4 software to improve probe accuracy close to the boundary. The sensitivity in TSL corresponds to NORM_{x,y,z} * *ConvF* whereby the uncertainty corresponds to that given for *ConvF*. A frequency dependent *ConvF* is used in DASY version 4.4 and higher which allows extending the validity from ± 50 MHz to ± 100 MHz.
- Spherical isotropy (3D deviation from isotropy)**: in a field of low gradients realized using a flat phantom exposed by a patch antenna.
- Sensor Offset**: The sensor offset corresponds to the offset of virtual measurement center from the probe tip (on probe axis). No tolerance required.

Probe ET3DV6

SN:1610

Manufactured:	July 27, 2001
Last calibrated:	November 17, 2006
Recalibrated:	November 14, 2007

Calibrated for DASY Systems

(Note: non-compatible with DASY2 system!)

DASY - Parameters of Probe: ET3DV6 SN:1610

Sensitivity in Free Space^A

NormX	1.73 ± 10.1%	$\mu\text{V}/(\text{V}/\text{m})^2$
NormY	1.70 ± 10.1%	$\mu\text{V}/(\text{V}/\text{m})^2$
NormZ	1.74 ± 10.1%	$\mu\text{V}/(\text{V}/\text{m})^2$

Diode Compression^B

DCP X	93 mV
DCP Y	95 mV
DCP Z	92 mV

Sensitivity in Tissue Simulating Liquid (Conversion Factors)

Please see Page 8.

Boundary Effect

TSL 900 MHz Typical SAR gradient: 5 % per mm

Sensor Center to Phantom Surface Distance		3.7 mm	4.7 mm
SAR _{be} [%]	Without Correction Algorithm	10.3	6.1
SAR _{be} [%]	With Correction Algorithm	1.6	0.7

TSL 1750 MHz Typical SAR gradient: 10 % per mm

Sensor Center to Phantom Surface Distance		3.7 mm	4.7 mm
SAR _{be} [%]	Without Correction Algorithm	9.9	6.1
SAR _{be} [%]	With Correction Algorithm	0.0	0.8

Sensor Offset

Probe Tip to Sensor Center 2.7 mm

The reported uncertainty of measurement is stated as the standard uncertainty of measurement multiplied by the coverage factor k=2, which for a normal distribution corresponds to a coverage probability of approximately 95%.

^A The uncertainties of NormX,Y,Z do not affect the E²-field uncertainty inside TSL (see Page 8).

^B Numerical linearization parameter: uncertainty not required.

Frequency Response of E-Field

(TEM-Cell:ifi110 EXX, Waveguide: R22)

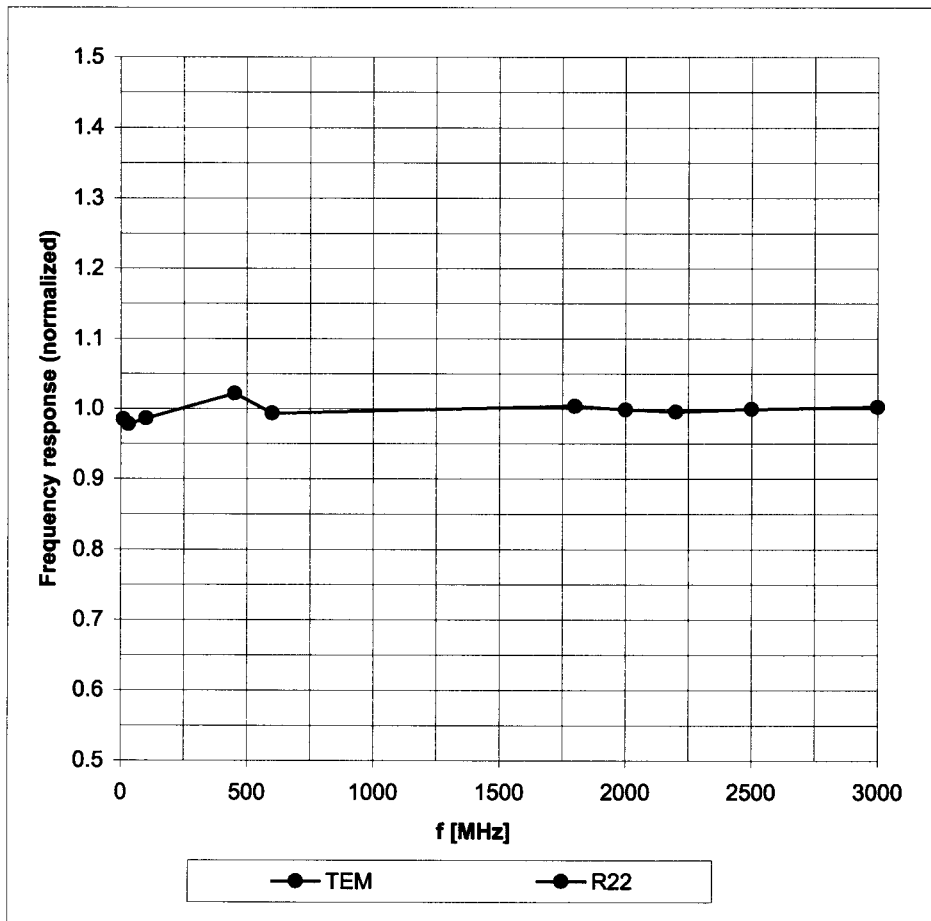

Uncertainty of Frequency Response of E-field: $\pm 6.3\%$ ($k=2$)

Receiving Pattern (ϕ), $\vartheta = 0^\circ$

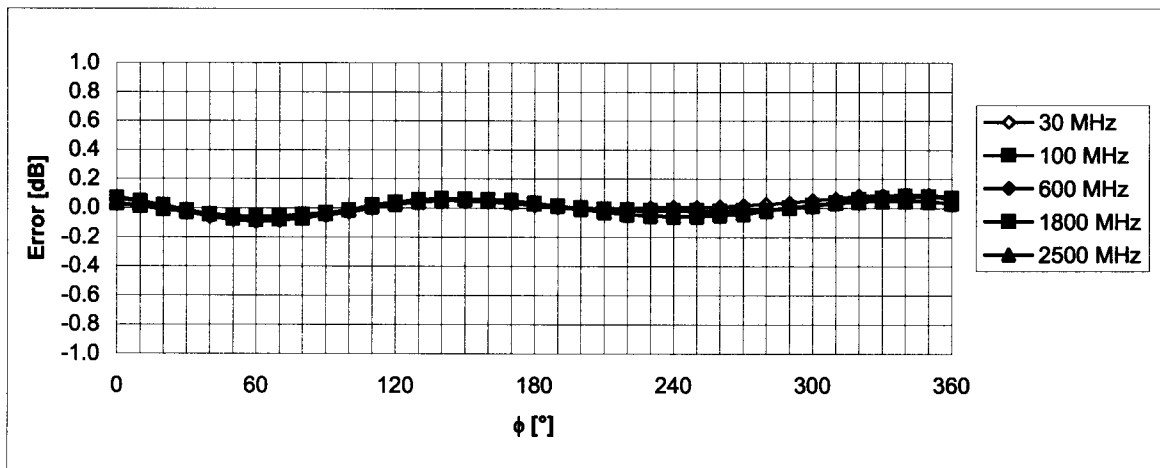
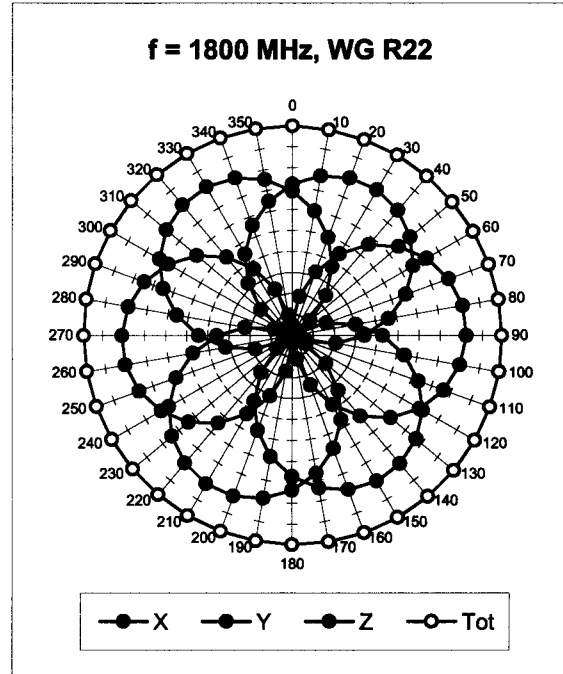
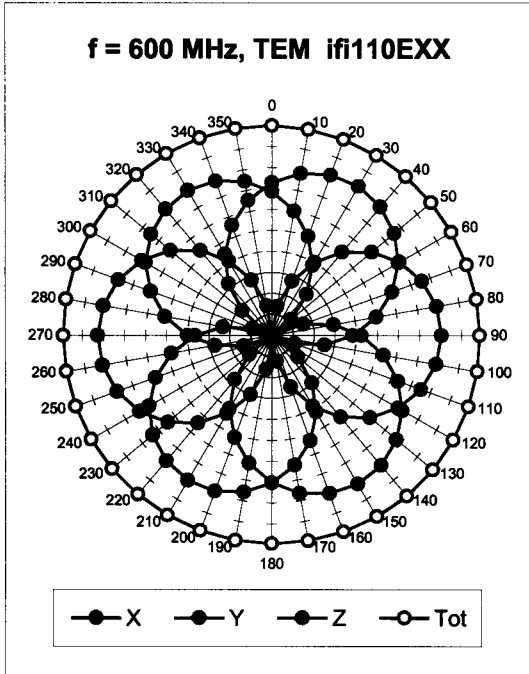

Uncertainty of Axial Isotropy Assessment: $\pm 0.5\%$ ($k=2$)

Dynamic Range f(SAR_{head}) (Waveguide R22, f = 1800 MHz)

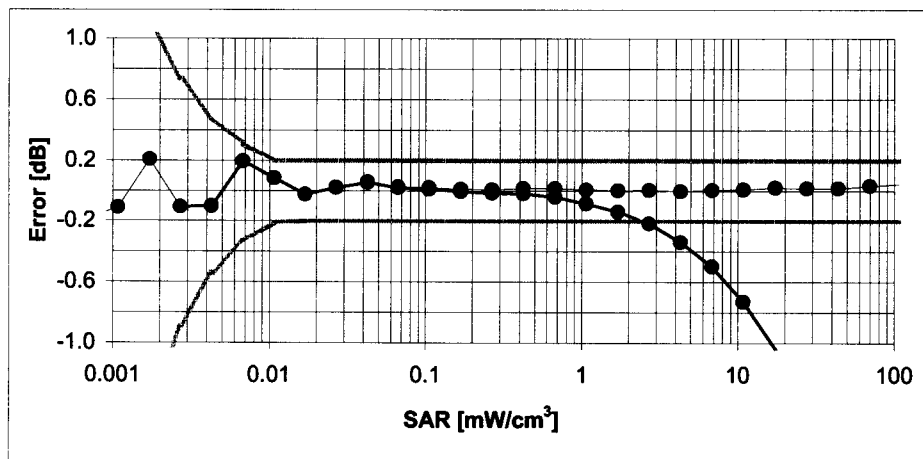
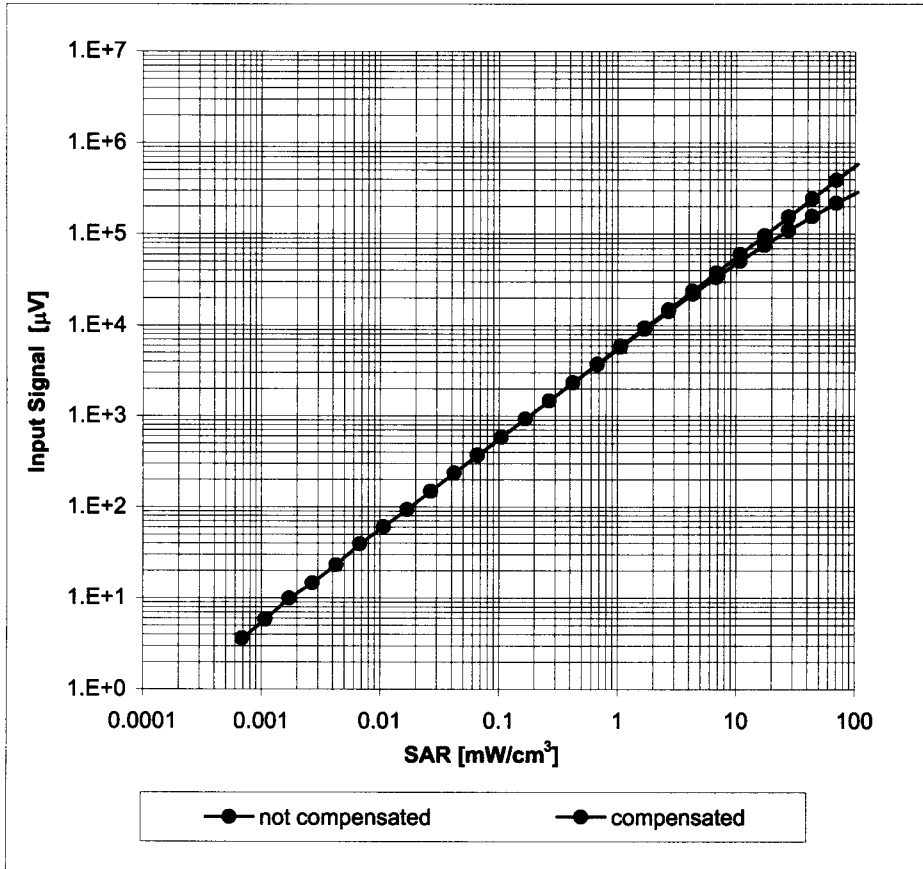

Uncertainty of Linearity Assessment: $\pm 0.6\%$ (k=2)

Conversion Factor Assessment

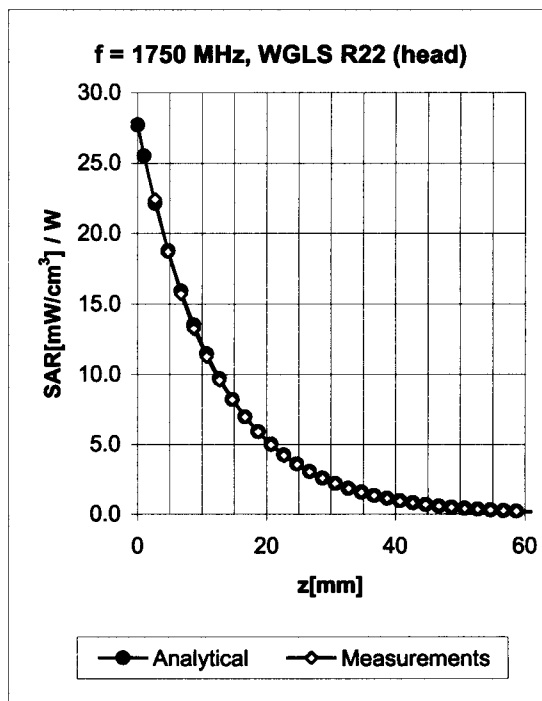
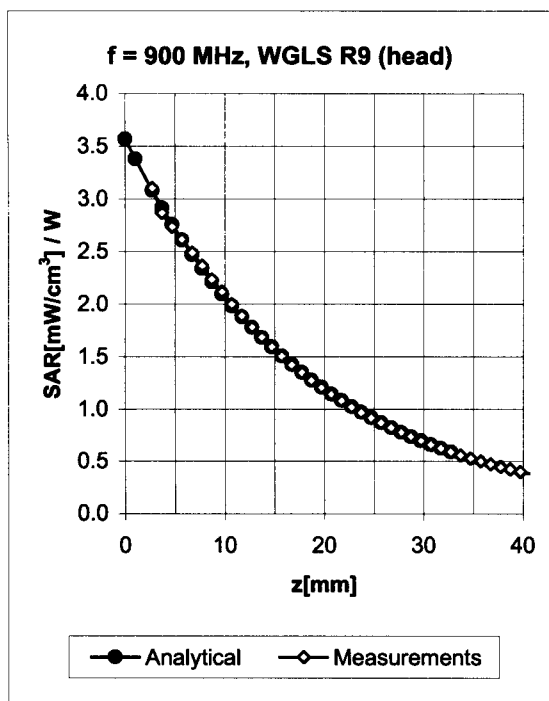

f [MHz]	Validity [MHz] ^c	TSL	Permittivity	Conductivity	Alpha	Depth	ConvF Uncertainty
835	± 50 / ± 100	Head	41.5 ± 5%	0.90 ± 5%	0.76	1.87	6.69 ± 11.0% (k=2)
900	± 50 / ± 100	Head	41.5 ± 5%	0.97 ± 5%	0.73	1.94	6.59 ± 11.0% (k=2)
1750	± 50 / ± 100	Head	40.1 ± 5%	1.37 ± 5%	0.81	1.69	5.35 ± 11.0% (k=2)
1900	± 50 / ± 100	Head	40.0 ± 5%	1.40 ± 5%	0.87	1.65	5.18 ± 11.0% (k=2)
2450	± 50 / ± 100	Head	39.2 ± 5%	1.80 ± 5%	0.78	1.91	4.70 ± 11.8% (k=2)
835	± 50 / ± 100	Body	55.2 ± 5%	0.97 ± 5%	0.76	1.93	6.39 ± 11.0% (k=2)
900	± 50 / ± 100	Body	55.0 ± 5%	1.05 ± 5%	0.66	2.00	6.07 ± 11.0% (k=2)
1750	± 50 / ± 100	Body	53.4 ± 5%	1.49 ± 5%	0.77	1.94	4.89 ± 11.0% (k=2)
1900	± 50 / ± 100	Body	53.3 ± 5%	1.52 ± 5%	0.74	1.99	4.68 ± 11.0% (k=2)
2450	± 50 / ± 100	Body	52.7 ± 5%	1.95 ± 5%	0.90	1.73	4.09 ± 11.8% (k=2)

^c The validity of ± 100 MHz only applies for DASY v4.4 and higher (see Page 2). The uncertainty is the RSS of the ConvF uncertainty at calibration frequency and the uncertainty for the indicated frequency band.

Deviation from Isotropy in HSL

Error (ϕ , ϑ), $f = 900$ MHz

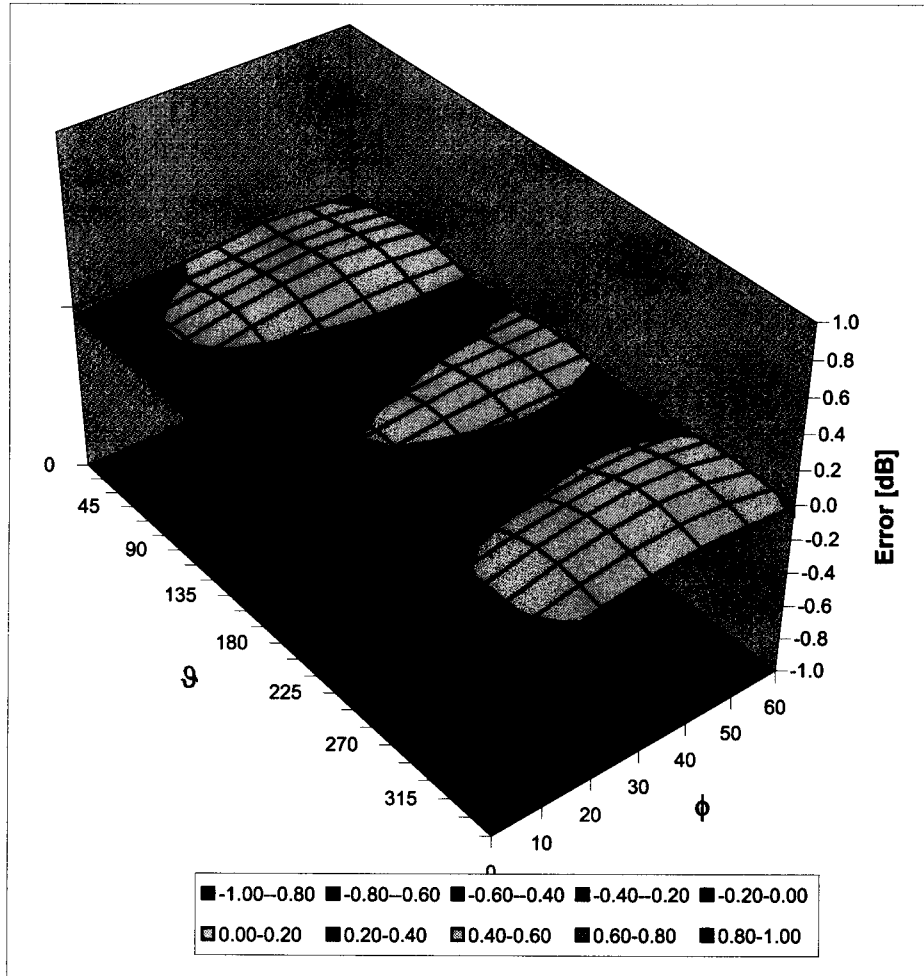

Uncertainty of Spherical Isotropy Assessment: $\pm 2.6\%$ ($k=2$)