

Scale 1:1

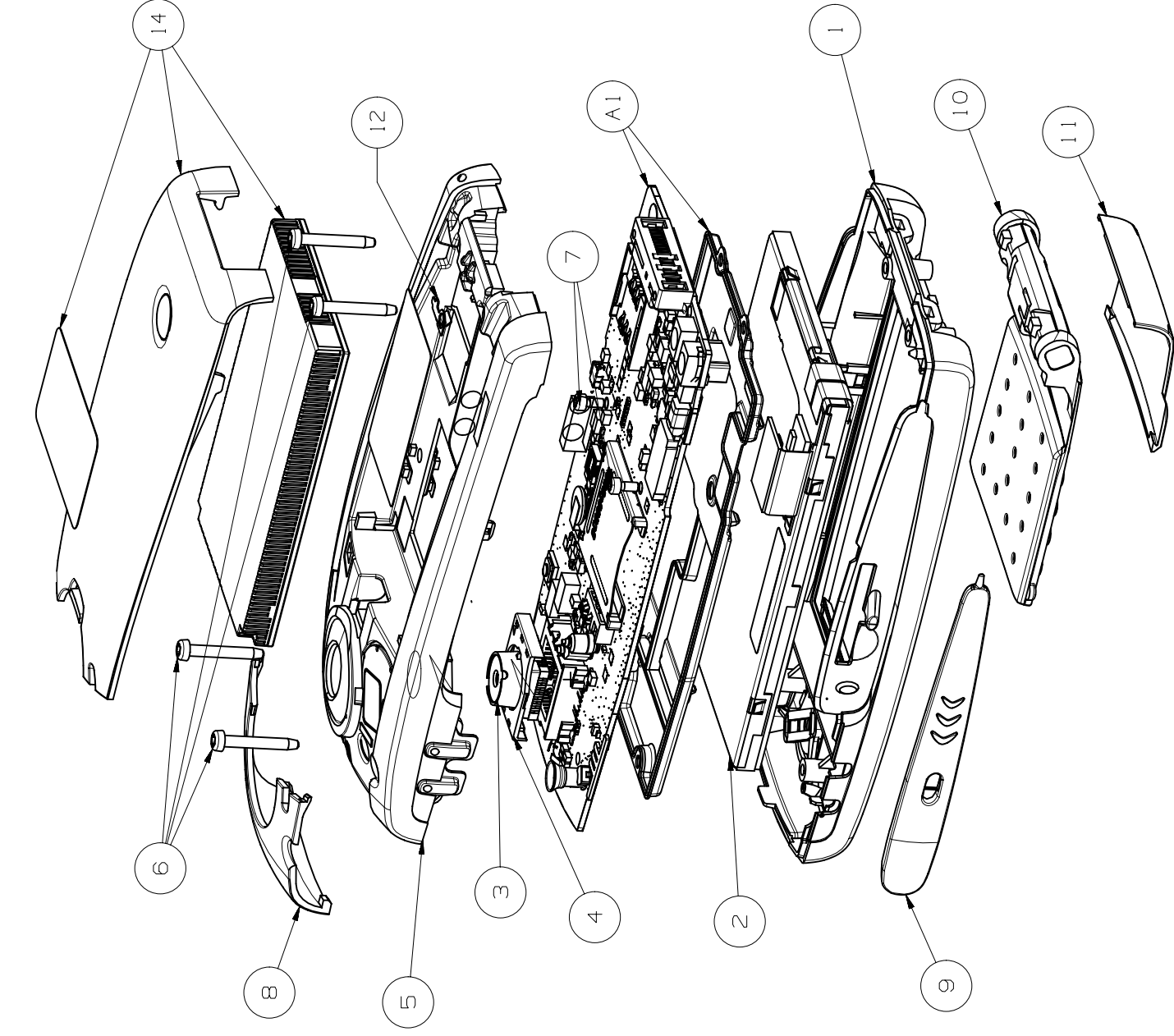

Notes:

- Ⓐ) Contains Shielding pot and ROA.
- Ⓘ) Torque 30±2 Ncm.
- Ⓙ) Torque 15±2 Ncm.
- ⓓ) Label shall be positioned fully within recess. Included in DPY.
- ⓔ) Included in DPY

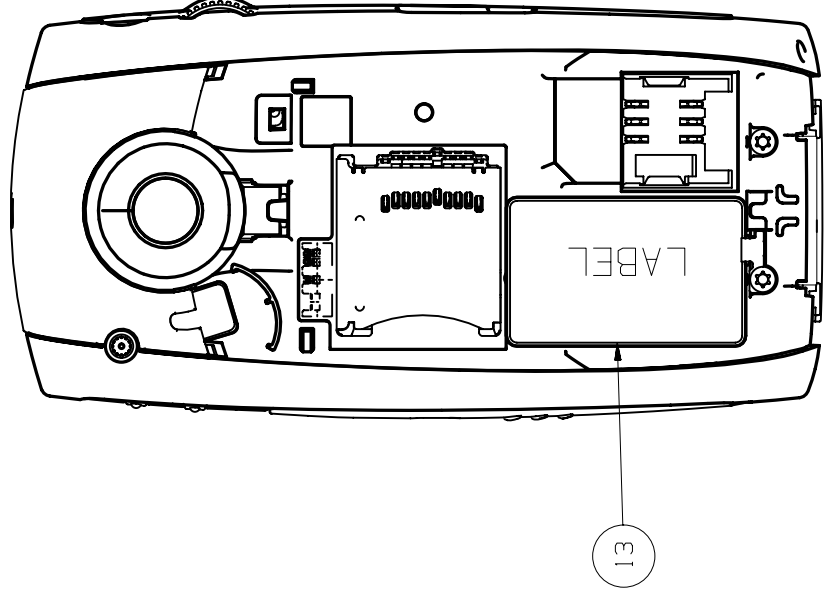

View showing positioning of label

ASSEMBLY DRAWING

Sony Ericsson

Drawing Rules

Tolerance



CAD: UNIGRAPHICS V16.0

Reference

Scale

Units mm

Size

A3

Prepared (Also Subject Responsible if Other)

SEM/GKT/LZ Anders Persson

Doc Responsible/Approved

GKT/LZC (S. Pettersson)

Date

2002-04-25

Rev

A

Product Name

Smartphone unit

Document No.

15188-KRH 101 05 Uen

Sheet

1 (1)



Limited Internal
MARKING DRAWING

Prepared (also subject responsible if other)

SEM/GKT/LDC Arne Rahm

Approved

KI/SEM/GKT/LZC (Sven Pettersson)

Checked

No.

151 86-SVV 104 57/1 Uen

Date

2002-05-23

Rev

A

Reference

Type 713 05 01-BV.

Smartphone P800

1. Label

The label used for marking is defined in the Manufacturing Specification on the SVF 930 361/1.

2. Placing

The label shall be placed on the back of the telephone according to the Assembly Drawing (151 88-) for the KRH.

3. Print layout

Printing area 31.6 x 18.5 mm.

Line nbr

1.	2541/1 RXX Rywxxx P800	x
2.	Type 713 05 01-BV G1G2G3HY1Y2Y3	x
3.		x
4.	XXXXXXXX-XX-XXXXXXXX-X	x
5.		
6.	XXXXXXXXXX yyWww CDAxxxxxxx Rxx	
7.	CAN: xxxxxxxx-xxxxxxxxxxxx	
8.	FCC ID: PY7XXXXXXXXXX	
9.		
10.		
11.		

Line	Text	Text height
1.	Reduced DPY-number, R-state, Repair week, Model name	min 1.2 mm
2.	Type number, G1,G2, G3, H, Y1, Y2, Y3 field	min 1.2 mm
3.	IMEI number as bar code	min 3.5 mm
4.	IMEI number as characters	min 1.2 mm
5.	Serial number as bar code	min 3.5 mm
6.	Serial number as characters, production week, CDA number , R-state. TBD	min 1.2 mm
7.	Country approval mark 1. TBD	min 1.2 mm
8.	Country approval mark 2. TBD	min 1.5 mm
9.	Approval marks (1, 2), angled 90° cclw, Additional field, angled 90° cclw	Min 5.0 mm min 2.5 mm min 1.2 mm
10.	Sony Ericsson trademark, angled 90° cclw	min 2.0 mm
11.	Marking of origin, angled 90° cclw	min 1.2 mm

Prepared (also subject responsible if other)

SEM/GKT/LDC Arne Rahm

Approved

KI/SEM/GKT/LZC Sven Pettersson

Checked

Limited Internal
MARKING DRAWING

No.

151 86-SVV 104 57/1 Uen

Date

2002-05-23

Rev



A

Reference

4. Print layout Prototype label

Printing area 31.6 x 18.5 mm.

Line nbr

1.	147/x RXX Rywwxx P800	Sony Ericsson Marking of origin
2.	NOT TYPE APPROVED	
3.		
4.	004601-01-XXXXXX-X	
5.		
6.	XXXXXXXXXX yyWww CDAxxxxxxx Rxx	
7.		
8.	PROTOTYPE XXX	
9.		
10.		
11.		

Line	Text	Text height
1.	Prototype DPY-number, R-state, Repair week, Model name	min 1.2 mm
2.	"NOT TYPE APPROVED"	min 1.2 mm
3.	IMEI number as bar code. See line 4.	min 3.5 mm
4.	IMEI number as characters. Must consist of 004601-01-SNR-CD . Were SNR = serial number 270000-274999. CD = check digit 0-9.	min 1.2 mm
5.	Serial number as bar code	min 3.5 mm
6.	Serial number as characters, production week, CDA number, R-state. TBD	min 1.2 mm
7. 8	"PROTOTYPE XXX" (EPx, FPx, etc)	min 3.5 mm
9.	Blank	min 1.2 mm
10.	Sony Ericsson trademark, angled 90° cclw	min 2.0 mm
11.	Marking of origin, angled 90° cclw	min 1.2 mm

5. Definitions:

- | | | |
|----|--------------------|--|
| 1. | Reduced DPY-number | The DPY number for the product without DPY 101 e.g. if you are producing DPY 101 2541/1 the printing should be 2541/1. (7 pos) |
| | R-state | The R-state for the DPY according to the 1095- for the DPY. (3 pos) |
| | Repair week | The field shall be left blank unless a repair centre repairs the unit. The repair week shall then be given as Rywwxx. (R = repair, y = year, ww = week, xx = R-state e.g. 1A). (6 pos) |

Limited Internal
 MARKING DRAWING

Prepared (also subject responsible if other)

SEM/GKT/LDC Arne Rahm

Approved

KI/SEM/GKT/LZC Sven Pettersson

Checked

No.

151 86-SVV 104 57/1 Uen

Date

2002-05-23

Rev

A

Reference

	Model name	The model name P800
	Approval mark	1. According to 1424 - SVF 930 196
2.	Ericsson Type number	The type number 7130501-BV and shall be printed "Type 7130501-BV". (15 pos)
	G1-field	R-state identification of the CXC-phone sw according to the Type approval report 17452- for the SVV.
	G2-field	R-state identification of the CXC-organizer sw according to the Type approval report 17452- for the SVV.
	G3-field	R-state identification of the CXC-BT sw according to the Type approval report 17452- for the SVV.
	H-field	R-state identification of the hardware according to the Type approval report 17452- for the SVV.
	Y1-field	R-state identification of the KRH according to the Marking drawing 1/151 86- for the SVV.
	Y2-field	ROA structure identification according to the Marking drawing 1/151 86- for the SVV.
	Y3-field	R-state identification of the ROA according to the Marking drawing 1/151 86- for the SVV.
3.	IMEI number as bar code	See below for definition of IMEI-number. The bar code shall only contain the digits of the IMEI number (no dash).
4.	IMEI number as characters	The IMEI number has format: TAC-FAC-SNR-CD (18 pos) TAC = TBD (Type approval code, V25) (6 pos) FAC = 45 for the Hungary factory (2 pos) = 61 for the Linköping factory = 62 for the Beijing factory = 63 for the Nanjing factory = 71 for the Shah Alam factory SNR = Serial number from 000 000 to 999 999 (6 pos) CD = A check digit, from 0-9, calculated (1 pos) according to the Luhn formula (ISO/IEC 7812), GSM 02.16.
5.	Serial number as bar code	According to Ericsson corporate standard 102 01 - 109.
6.	Serial number as characters	According to Ericsson group standard (10 pos) 0012-101. Ericsson group factory number system according the Ericsson corporate standard 1120-101 Factory codes: Linköping A61 Beijing CB5 Nanjing CB9 Shah Alam BD3 Hungary TZ4
	Production week	The production week shall be given as yyWww (yy = year, ww = week) according to the ISO 8601 standard. (5 pos)

Prepared (also subject responsible if other)

SEM/GKT/LDC Arne Rahm

Approved

KI/SEM/GKT/LZC Sven Pettersson

Checked

**Limited Internal
MARKING DRAWING**

No.

151 86-SVV 104 57/1 Uen

Date

2002-05-23

Rev

A

Reference

- | | |
|---|--|
| <p>CDA number,
R-state</p> <p>7. Country approval
mark 1</p> <p>8. Country approval
mark 2</p> <p>9. Approval marks</p> <p>Additional field</p> <p>10. Sony Ericsson
Trademark</p> <p>11. Marking of origin</p> | <p>The number on the CDA file including the R-state of the file. (16 pos)</p> <p>Consist of text: IC xxxxxx-xxxxxxx TBD</p> <p>Consist of text: FCC ID: PY7xxxxxTBD within a frame with height > 1,5 mm.</p> <p>1. According to 1424 - SVF 930 52</p> <p>2. The notified body number according to the TTE Annex III certificate for the production plant. If this is not available, use the notified body number from the type approval certificate (normally 0682). The print size (height) for the notified body number (e.g. 0682) and the corresponding approval marks shall be minimum 5 mm. This is a regulatory requirement.</p> <p>The field shall be left blank unless otherwise stated in a separate 2/151 86- document for the SVV.</p> <p>According to corporate standard 190 89-EN/LZT 108 5347.</p> <p>The field shall be left blank unless otherwise stated in a separate 3/151 86-SVV document.</p> |
|---|--|