

Prepared by  
HW PM Torbjörn Samuelsson  
Contents responsible if other than preparer

Date  
2013-12-20  
Remarks  
This document is handled in SPACE

Approved by  
HW PM Torbjörn Samuelsson

---

- **Type number: RD-0071**
- **FCC id: PY7-RD0071**
- **IC id: 4170B-RD0071**

## Specification Core Unit Marking

### Contents

1	Printing information.....	2
2	Contents and positioning of laser etch printing .....	2
2.1	Contents.....	2
2.2	Positioning of printing .....	3
3	REVISION INFORMATION .....	4

### Abstract

This document describes the label printing for Everest (SmartBand 2, SWR12)  
1291-1904

## 1 Printing information



The printing is laser etched in a grey color. The printing shall be sharp and well readable and shall withstand wearing.



## 2 Contents and positioning of laser etch printing

### 2.1 Contents

The label shall have the following content, Position and alignment may vary:

RTL type

Position	Text	Align	Note
Top cover	Model: <b>SWR12</b>	3,5pt	Commercial name Shall be used for MP only
Top cover	1291-1904.x	3,5pt	X = revision for MP
Top cover	Type: RD-0071 AAA	3,5pt	Type: RD-XXXX EFF E=HW version FF=SW version  Three blank spaces between the Type No. and EFF
Top cover	FCC ID: PY7-RD0071	3,5pt	
Top cover	IC: 4170B-RD0071	3,5pt	
Top cover		NFC icon height: 3.0mm Isolation zone: 1.5mm	
Top cover	Made in China	3,5pt	
Top cover	yyWww	3,5pt	yy = production year ww = production week
Top cover	BDA: XXXXXXXXXXXX	3,5pt	actual unique BT address
Top cover	S/N: YYWWPSLCXXXXXXXXC	3,5pt	Note 1
Top cover	Li-ion電池のリサイクルにご協力を	Size: 1.0x9.5mm	Japanese Lithium Ion battery statement
Top cover	 <b>007-AC0284</b>	Symbol size: 3.0mm text 3,5pt	Telec number. JATE not needed Symbol size: 3mm, text 1mm height

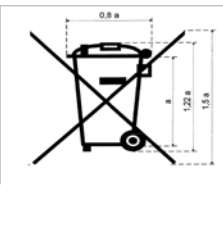
Top cover		height: 5.0mm height: 1.0mm for numbers	CE-mark, symbol height 5.0mm
Top cover		RCM height: 3.0mm	RCM compliance mark: Oceania (Australia, New Zealand, Fiji, Papa New Guinea)
Top cover		height:5.0 width:4.5	<b>Recycling WEEE</b> icon ref.doc. 1003-0743 Min size: 5mm height of cross

Note1: Serial No according to below:  
**YYWWPSLCXXXXXC**  
 YY = Year  
 WW = Week of production  
 P = Product Code  
 S = Supplier Site (D for Goertek)  
 L = Production Line  
 XXXXXX = Serial value  
 C = Checksum (in two positions)

## 2.2 Positioning of printing

The logotype, text and safety approval symbols mentioned under content shall be placed on the top surface on the module.

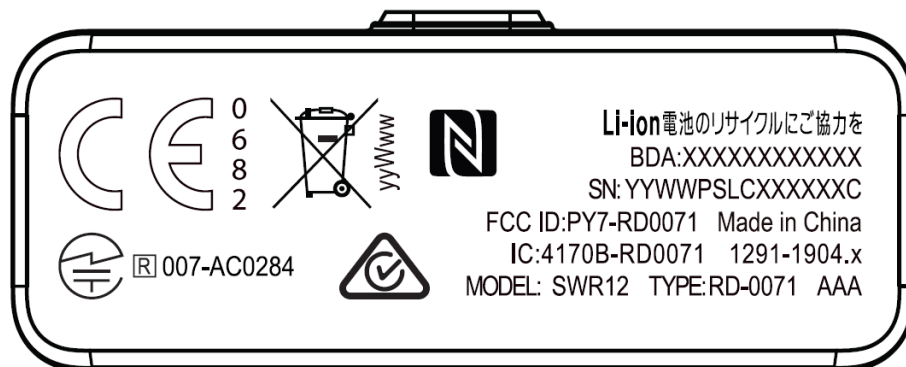

## 3 REVISION INFORMATION

<u>Version</u>	<u>Date</u>	<u>Note</u>
1		Development revision