



FCC RF Test Report

APPLICANT : Sony Mobile Communications Inc.
EQUIPMENT : Smart phone
BRAND NAME : Sony
FCC ID : PY7-PM0952
STANDARD : FCC Part 15 Subpart C §15.247
CLASSIFICATION : (DTS) Digital Transmission System

The product was received on Feb. 04, 2016 and testing was completed on Feb. 26, 2016. We, SPORTON INTERNATIONAL INC., would like to declare that the tested sample has been evaluated in accordance with the test procedures and has been in compliance with the applicable technical standards.

The test results in this report apply exclusively to the tested model / sample. Without written approval of SPORTON INTERNATIONAL INC., the test report shall not be reproduced except in full.

Reviewed by: Joseph Lin / Supervisor

Approved by: Jones Tsai / Manager



SPORTON INTERNATIONAL INC.

No. 52, Hwa Ya 1st Rd., Hwa Ya Technology Park, Kwei-Shan District, Tao Yuan City, Taiwan, R.O.C.



TABLE OF CONTENTS

REVISION HISTORY..... 3

SUMMARY OF TEST RESULT 4

1 GENERAL DESCRIPTION 5

 1.1 Applicant 5

 1.2 Manufacturer 5

 1.3 Product Feature of Equipment Under Test 5

 1.4 Modification of EUT 7

 1.5 Testing Location 7

 1.6 Applicable Standards 7

2 TEST CONFIGURATION OF EQUIPMENT UNDER TEST 8

 2.1 Carrier Frequency Channel 8

 2.2 Pre-Scanned RF Power 9

 2.3 Test Mode 9

 2.4 Connection Diagram of Test System 10

 2.5 Support Unit used in test configuration and system 11

 2.6 EUT Operation Test Setup 11

 2.7 Measurement Results Explanation Example 11

3 TEST RESULT 12

 3.1 6dB and 99% Bandwidth Measurement 12

 3.2 Output Power Measurement 14

 3.3 Power Spectral Density Measurement 15

 3.4 Conducted Band Edges and Spurious Emission Measurement 17

 3.5 Radiated Band Edges and Spurious Emission Measurement 30

 3.6 AC Conducted Emission Measurement 36

 3.7 Antenna Requirements 40

4 LIST OF MEASURING EQUIPMENT 41

5 UNCERTAINTY OF EVALUATION 43

APPENDIX A. CONDUCTED TEST RESULTS

APPENDIX B. RADIATED TEST RESULTS

APPENDIX C. RADIATED SPURIOUS EMISSION PLOTS



REVISION HISTORY

REPORT NO.	VERSION	DESCRIPTION	ISSUED DATE
FR620405C	Rev. 01	Initial issue of report	Apr. 28, 2016
FR620405C	Rev. 02	Updating EUT information in section 1.3.	May 10, 2016
FR620405C	Rev. 03	Adjust band edge and fundamental plot position in appendix C.	May 26, 2016



SUMMARY OF TEST RESULT

Report Section	FCC Rule	Description	Limit	Result	Remark
3.1	15.247(a)(2)	6dB Bandwidth	$\geq 0.5\text{MHz}$	Pass	-
3.1	-	99% Bandwidth	-	Pass	-
3.2	15.247(b)	Power Output Measurement	$\leq 30\text{dBm}$	Pass	-
3.3	15.247(e)	Power Spectral Density	$\leq 8\text{dBm}/3\text{kHz}$	Pass	-
3.4	15.247(d)	Conducted Band Edges	$\leq 20\text{dBc}$	Pass	-
		Conducted Spurious Emission		Pass	-
3.5	15.247(d)	Radiated Band Edges and Radiated Spurious Emission	15.209(a) & 15.247(d)	Pass	Under limit 3.26 dB at 4924.000 MHz
3.6	15.207	AC Conducted Emission	15.207(a)	Pass	Under limit 15.90 dB at 0.478 MHz
3.7	15.203 & 15.247(b)	Antenna Requirement	N/A	Pass	-



1 General Description

1.1 Applicant

Sony Mobile Communications Inc.

4-12-3 Higashi-Shinagawa, Shinagawa-ku, Tokyo, 140-0002, Japan

1.2 Manufacturer

Sony Mobile Communications Inc.

4-12-3 Higashi-Shinagawa, Shinagawa-ku, Tokyo, 140-0002, Japan

1.3 Product Feature of Equipment Under Test

GSM/WCDMA/LTE, Bluetooth, DTS/UNII, a/b/g/n, GPS and NFC

Product Specification subjective to this standard	
Antenna Type / Gain	PIFA Antenna type with gain -2.00 dBi

EUT Information List				
IMEI	HW Version	SW Version	S/N	Performed Test Item
004402455816987	A	36.0.A.1.28	WUJ01M8LEX	RF conducted measurement
004402455814016			WUJ01M8BA5	Radiated Spurious Emission
004402455814008			WUJ01M8BA4	Conducted Emission



Accessory List	
AC Adapter	Model No. : UCH20
	Type No. : AC-0060-US
	S/N :
	1315W52500072 (for radiated spurious emission) 1315W52500025 (for conducted emission)
Earphone	Model No. : MH410c
	Type No. : AG-1110
	S/N :
	1435204403A9122 (for radiated spurious emission) 14321E5F00817B2 (for conducted emission)
USB Cable	Model No. : UCB16
	Type No. : AI-0142
	S/N :
	1602A901000542E (for radiated spurious emission) 1602A90A000378C (for conducted emission)

Note:

1. Above EUT list and accessory list used are electrically identical per declared by manufacturer.
2. Above the accessories list are used to exercise the EUT during test.
3. For other wireless features of this EUT, test report will be issued separately.



1.4 Modification of EUT

No modifications are made to the EUT during all test items.

1.5 Testing Location

Sporton Lab is accredited to ISO 17025 by Taiwan Accreditation Foundation (TAF code : 1190) and the FCC designation No. TW1022 under the FCC 2.948(e) by Mutual Recognition Agreement (MRA) in FCC Test.

Test Site	SPORTON INTERNATIONAL INC.		
Test Site Location	No. 52, Hwa Ya 1 st Rd., Hwa Ya Technology Park, Kwei-Shan District, Tao Yuan City, Taiwan, R.O.C. TEL: +886-3-327-3456 FAX: +886-3-328-4978		
Test Site No.	Sporton Site No.		
	TH05-HY	CO05-HY	03CH07-HY

Note: The test site complies with ANSI C63.4 2014 requirement.

1.6 Applicable Standards

According to the specifications of the manufacturer, the EUT must comply with the requirements of the following standards:

- ♦ FCC Part 15 Subpart C §15.247
- ♦ FCC KDB Publication No. 558074 D01 DTS Meas. Guidance v03r05
- ♦ ANSI C63.10-2013

Remark:

1. All test items were verified and recorded according to the standards and without any deviation during the test.
2. This EUT has also been tested and complied with the requirements of FCC Part 15, Subpart B, recorded in a separate test report.



2 Test Configuration of Equipment Under Test

The EUT has been associated with peripherals and configuration operated in a manner tended to maximize its emission characteristics in a typical application. Frequency range investigated: conducted emission (150 kHz to 30 MHz) and radiated emission (9 kHz to the 10th harmonic of the highest fundamental frequency or to 40 GHz, whichever is lower). For radiated measurement, pre-scanned in three orthogonal panels, X, Y, Z. The worst cases (X plane) were recorded in this report.

The final configuration from all the combinations and the worst-case data rates were investigated by measuring the maximum power across all the data rates and modulation modes under section 2.2.

Based on the worst configuration found above, the RF power setting is set individually to meet FCC compliance limit for the final conducted and radiated tests shown in section 2.3.

2.1 Carrier Frequency Channel

Frequency Band	Channel	Freq. (MHz)	Channel	Freq. (MHz)
2400-2483.5 MHz	1	2412	7	2442
	2	2417	8	2447
	3	2422	9	2452
	4	2427	10	2457
	5	2432	11	2462
	6	2437	-	-



2.2 Pre-Scanned RF Power

Preliminary tests were performed in different data rate and data rate associated with the highest power were chosen for full test shown in the following tables.

2.4GHz 802.11b mode				
Data Rate (MHz)	1M bps	2M bps	5.5M bps	11M bps
Peak Power (dBm)	20.99	20.76	20.64	20.68

2.4GHz 802.11g mode								
Data Rate (MHz)	6M bps	9M bps	12M bps	18M bps	24M bps	36M bps	48M bps	54M bps
Peak Power (dBm)	23.79	23.66	23.74	23.77	23.72	23.58	23.72	23.71

2.4GHz 802.11n HT20 mode								
Data Rate (MHz)	MCS0	MCS1	MCS2	MCS3	MCS4	MCS5	MCS6	MCS7
Peak Power (dBm)	21.66	21.43	21.28	21.33	21.44	21.53	21.58	21.61

2.4GHz 802.11n HT40 mode								
Data Rate (MHz)	MCS0	MCS1	MCS2	MCS3	MCS4	MCS5	MCS6	MCS7
Peak Power (dBm)	22.62	21.57	21.53	21.15	21.43	21.63	21.55	21.72

2.3 Test Mode

Final test mode of conducted test items and radiated spurious emissions are considering the modulation and worse data rates from the power table described in section 2.2.

Modulation	Data Rate
802.11b	1 Mbps
802.11g	6 Mbps
802.11n HT20	MCS0
802.11n HT40	MCS0

Test Cases	
AC Conducted Emission	Mode 1 : GSM1900 Idle + Bluetooth Link + WLAN (2.4GHz) Link + Camera + Earphone + USB Cable (Charging from Adapter)

2.4 Connection Diagram of Test System

<WLAN Tx Mode>

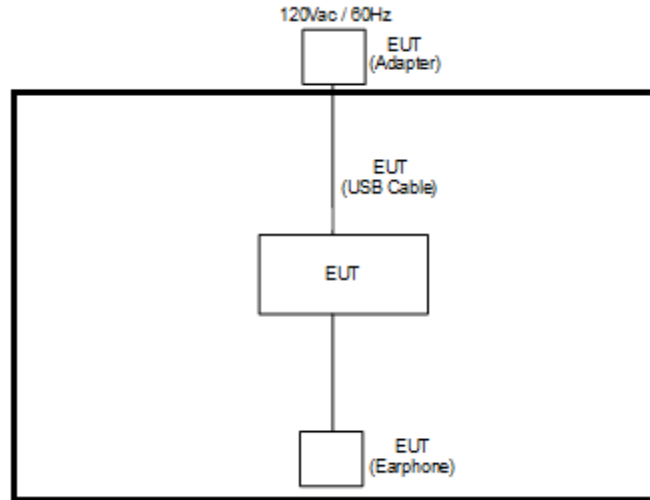

<AC Conducted Emission Mode>

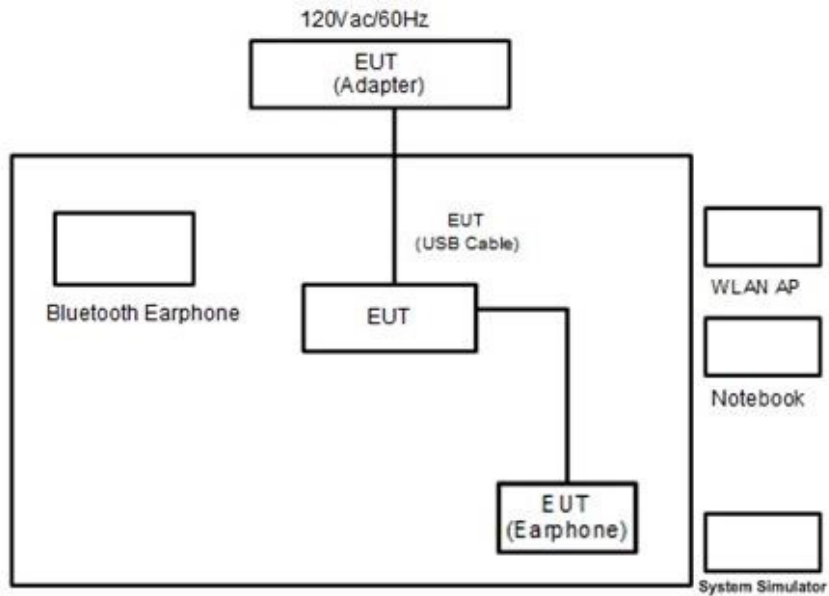



2.5 Support Unit used in test configuration and system

Item	Equipment	Trade Name	Model Name	FCC ID	Data Cable	Power Cord
1.	System Simulator	Anritsu	MT8820C	N/A	N/A	Unshielded, 1.8 m
2.	WLAN AP	D-Link	DIR-865L	KA2IR865LA1	N/A	Unshielded, 1.8 m
3.	Bluetooth Earphone	Samsung	SBH20	PY7-RD0010	Unshielded, 0.75 m	N/A
4.	Notebook	DELL	Latitude E6320	FCC DoC/ Contains FCC ID: QDS-BRCM1054	N/A	AC I/P: Unshielded, 1.2 m DC O/P: Shielded, 1.8 m
5.	SD Card	SanDisk	MicroSD HC	FCC DoC	N/A	N/A

2.6 EUT Operation Test Setup

For WLAN RF test items, an engineering test program was provided and enabled to make EUT continuous transmit/receive.

2.7 Measurement Results Explanation Example

For all conducted test items:

The offset level is set in the spectrum analyzer to compensate the RF cable loss and attenuator factor between EUT conducted output port and spectrum analyzer. With the offset compensation, the spectrum analyzer reading level is exactly the EUT RF output level.

Example :

The spectrum analyzer offset is derived from RF cable loss and attenuator factor.

Offset = RF cable loss + attenuator factor.

Following shows an offset computation example with cable loss 4.2 dB and 10dB attenuator.

$$\begin{aligned} \text{Offset(dB)} &= \text{RF cable loss(dB)} + \text{attenuator factor(dB)}. \\ &= 4.2 + 10 = 14.2 \text{ (dB)} \end{aligned}$$

3 Test Result

3.1 6dB and 99% Bandwidth Measurement

3.1.1 Limit of 6dB and 99% Bandwidth

The minimum 6 dB bandwidth shall be at least 500 kHz.

3.1.2 Measuring Instruments

The measuring equipment is listed in the section 4 of this test report.

3.1.3 Test Procedures

1. The testing follows FCC KDB Publication No. 558074 DTS D01 Meas. Guidance v03r05.
2. The RF output of EUT was connected to the spectrum analyzer by RF cable and attenuator. The path loss was compensated to the results for each measurement.
3. Set to the maximum power setting and enable the EUT transmit continuously.
4. Make the measurement with the spectrum analyzer's resolution bandwidth (RBW) = 100 kHz. Set the Video bandwidth (VBW) = 300 kHz. In order to make an accurate measurement. The 6 dB bandwidth must be greater than 500 kHz.
5. For 99% Bandwidth Measurement, the spectrum analyzer's resolution bandwidth (RBW) = 1MHz and set the Video bandwidth (VBW) = 3MHz.
6. Measure and record the results in the test report.

3.1.4 Test Setup

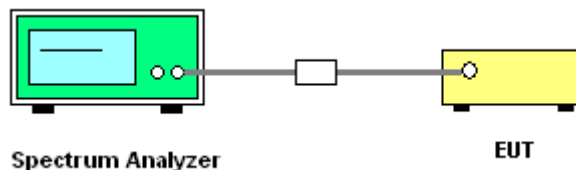

3.1.5 Test Result of 6dB and 99% Occupied Bandwidth

Please refer to Appendix A of this test report.

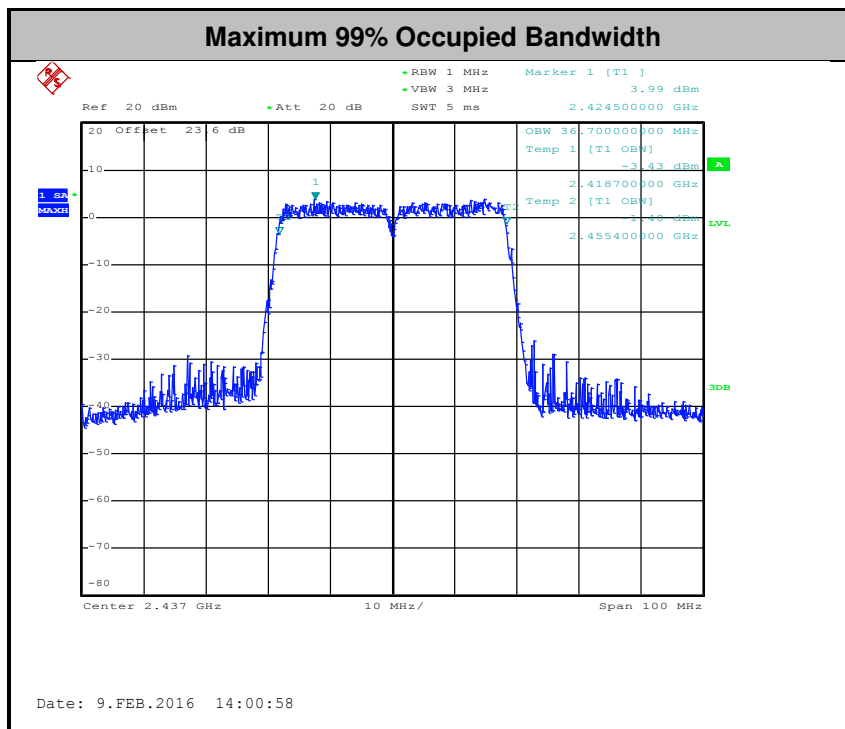
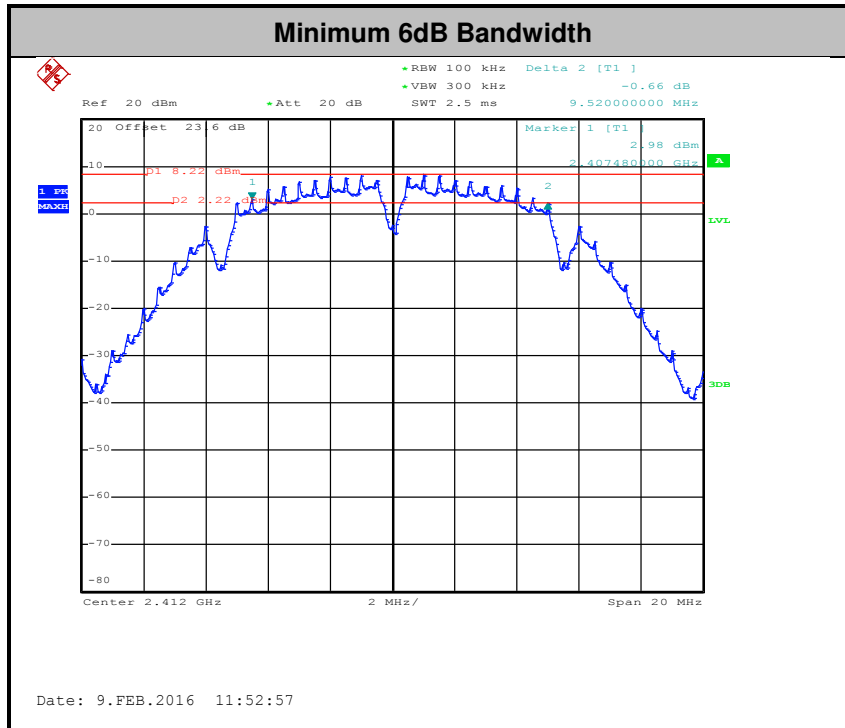

Note: The occupied channel bandwidth is maintained within the band of operation for all of the modulations.

3.2 Output Power Measurement

3.2.1 Limit of Output Power

For systems using digital modulation in the 2400-2483.5MHz, the limit for peak output power is 30dBm. If transmitting Antenna of directional gain greater than 6dBi are used the peak output power from the intentional radiator shall be reduced below the above stated value by the amount in dB that the directional gain of the Antenna exceeds 6 dBi. In case of point-to-point operation, the limit has to be reduced by 1dB for every 3dB that the directional gain of the Antenna exceeds 6dBi.

3.2.2 Measuring Instruments

The measuring equipment is listed in the section 4 of this test report.

3.2.3 Test Procedures

1. The testing follows the Measurement Procedure of FCC KDB No. 558074 DTS D01 Meas. Guidance v03r05 section 9.1.2 PKPM1 Peak power meter method.
2. The RF output of EUT was connected to the power meter by RF cable and attenuator. The path loss was compensated to the results for each measurement.
3. Set to the maximum power setting and enable the EUT transmit continuously.
4. Measure the conducted output power and record the results in the test report.

3.2.4 Test Setup

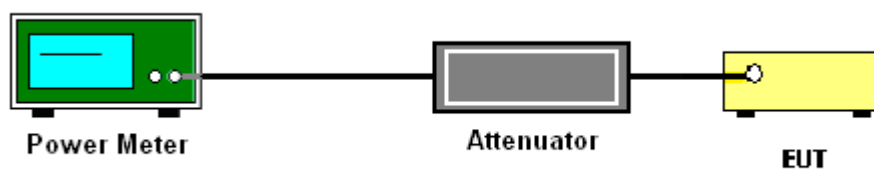

3.2.5 Test Result of Peak Output Power

Please refer to Appendix A of this test report.

3.2.6 Test Result of Average output Power (Reporting Only)

Please refer to Appendix A of this test report.

3.3 Power Spectral Density Measurement

3.3.1 Limit of Power Spectral Density

The peak power spectral density shall not be greater than 8dBm in any 3kHz band at any time interval of continuous transmission.

3.3.2 Measuring Instruments

The measuring equipment is listed in the section 4 of this test report.

3.3.3 Test Procedures

1. The testing follows Measurement Procedure 10.2 Method PKPSD of FCC KDB Publication No. 558074 D01 DTS Meas. Guidance v03r05.
2. The RF output of EUT was connected to the spectrum analyzer by RF cable and attenuator. The path loss was compensated to the results for each measurement.
3. Set to the maximum power setting and enable the EUT transmit continuously.
4. Make the measurement with the spectrum analyzer's resolution bandwidth (RBW) = 3 kHz. Video bandwidth VBW = 10 kHz In order to make an accurate measurement, set the span to 1.5 times DTS Channel Bandwidth. (6dB BW)
5. Detector = peak, Sweep time = auto couple, Trace mode = max hold, Allow trace to fully stabilize. Use the peak marker function to determine the maximum power level.
6. Measure and record the results in the test report.

3.3.4 Test Setup





3.3.5 Test Result of Power Spectral Density

Please refer to Appendix A of this test report.

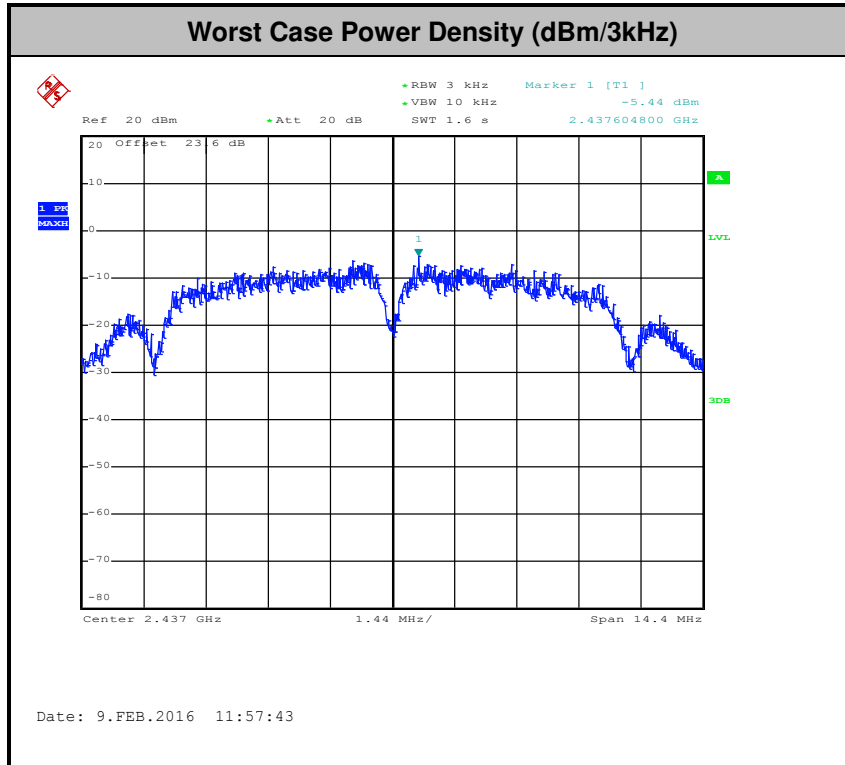

3.4 Conducted Band Edges and Spurious Emission Measurement

3.4.1 Limit of Conducted Band Edges and Spurious Emission Measurement

In any 100 kHz bandwidth outside of the authorized frequency band, the emissions which fall in the non-restricted bands shall be attenuated at least 20 dB / 30dB relative to the maximum PSD level in 100 kHz by RF conducted measurement and radiated emissions which fall in the restricted bands, as defined in Section 15.205(a), must also comply with the radiated emission limits specified in Section 15.209(a).

3.4.2 Measuring Instruments

The measuring equipment is listed in the section 4 of this test report.

3.4.3 Test Procedures

1. The testing follows FCC KDB Publication No. 558074 D01 DTS Meas. Guidance v03r05.
2. The RF output of EUT was connected to the spectrum analyzer by RF cable and attenuator. The path loss was compensated to the results for each measurement.
3. Set to the maximum power setting and enable the EUT transmit continuously.
4. Set RBW = 100 kHz, VBW=300 kHz, Peak Detector. Unwanted Emissions measured in any 100 kHz bandwidth outside of the authorized frequency band shall be attenuated by at least 20 dB relative to the maximum in-band peak PSD level in 100 kHz when maximum peak conducted output power procedure is used. If the transmitter complies with the conducted power limits based on the use of RMS averaging over a time interval, the attenuation required under this paragraph shall be 30 dB instead of 20 dB per 15.247(d).
5. Measure and record the results in the test report.
6. The RF fundamental frequency should be excluded against the limit line in the operating frequency band.

3.4.4 Test Setup

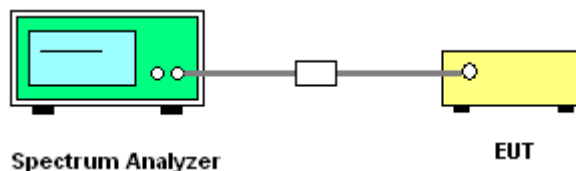



3.4.5 Test Result of Conducted Band Edges and Spurious Emission

Test Mode :	802.11b	Temperature :	21~25°C
Test Band :	2.4GHz Low	Relative Humidity :	51~54%
Test Channel :	01	Test Engineer :	Luffy Lin

WLAN 802.11b Channel 01

100kHz PSD reference Level	Low Channel Plot
-----------------------------------	-------------------------

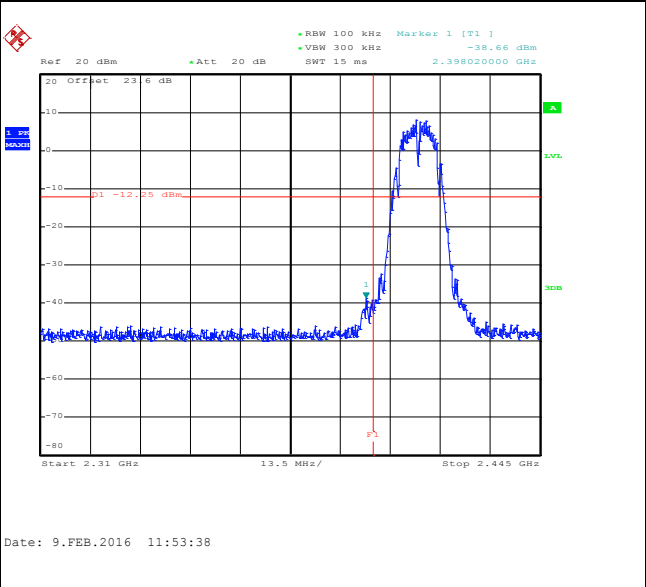
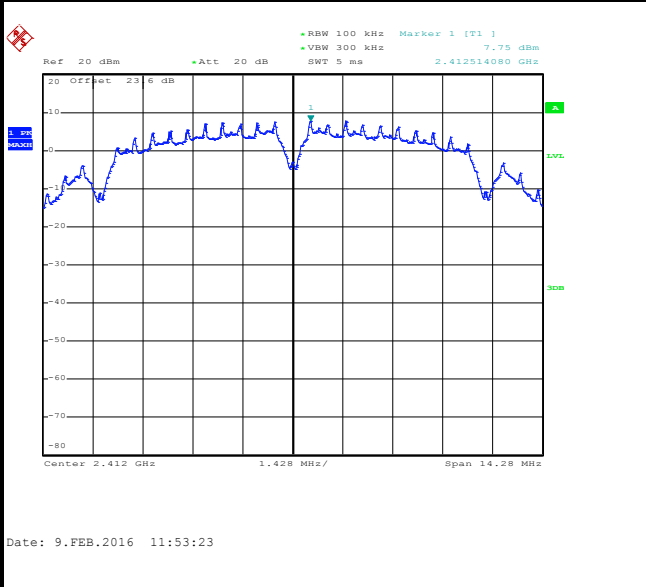

Spurious Emission 30MHz~3GHz

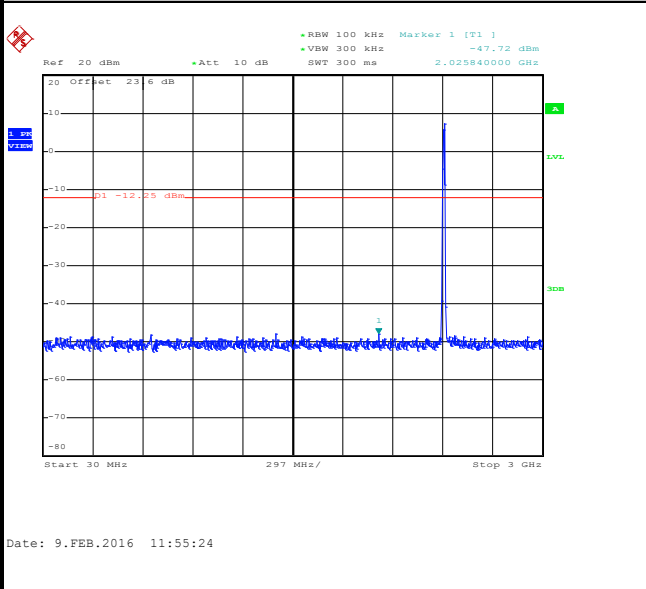

Spurious Emission 2GHz~25GHz

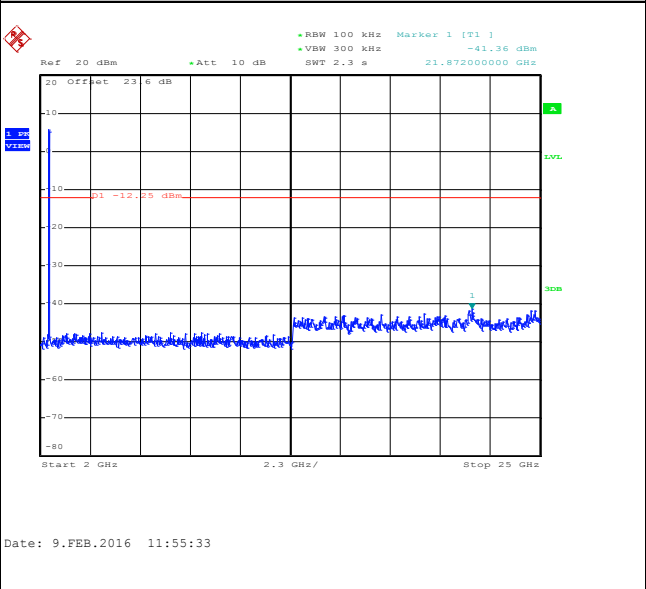



Test Mode :	802.11b	Temperature :	21~25°C
Test Band :	2.4GHz Mid	Relative Humidity :	51~54%
Test Channel :	06	Test Engineer :	Luffy Lin

WLAN 802.11b Channel 06

100kHz PSD reference Level

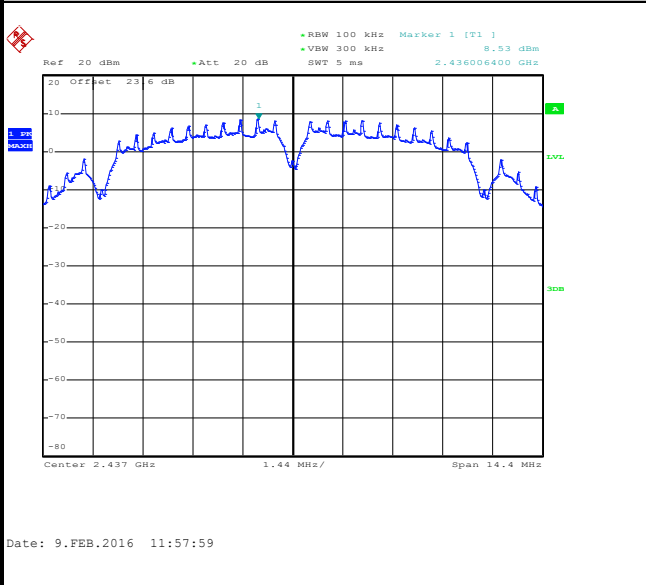

Spurious Emission 30MHz~3GHz

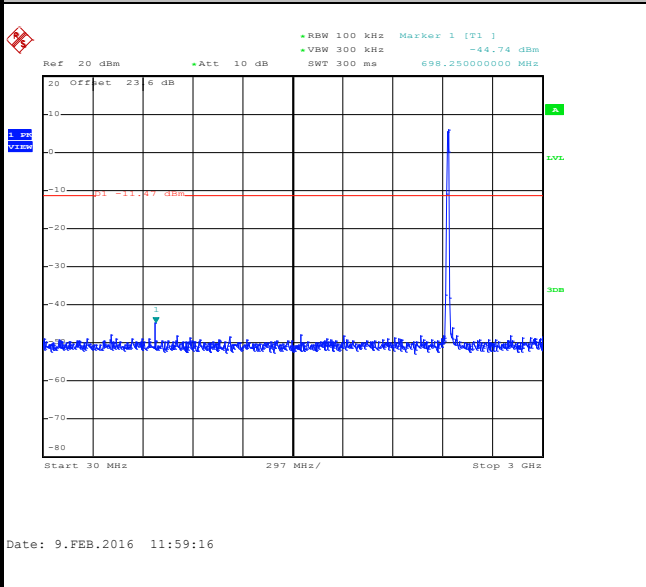

Spurious Emission 2GHz~25GHz

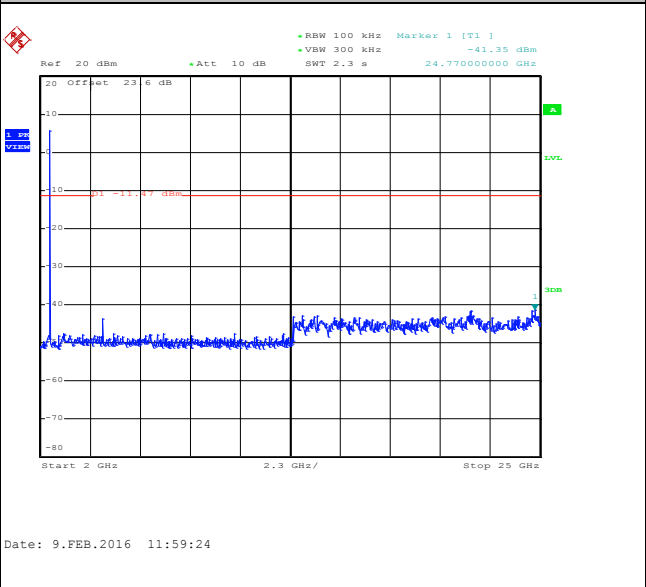



Test Mode :	802.11b	Temperature :	21~25°C
Test Band :	2.4GHz High	Relative Humidity :	51~54%
Test Channel :	11	Test Engineer :	Luffy Lin

WLAN 802.11b Channel 11

100kHz PSD reference Level

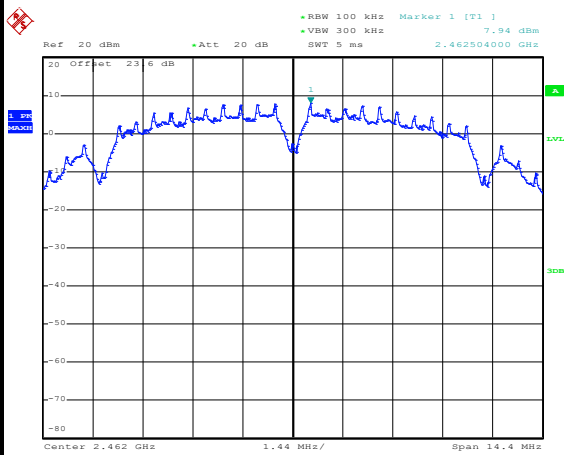

Date: 9.FEB.2016 12:02:56

High Channel Plot

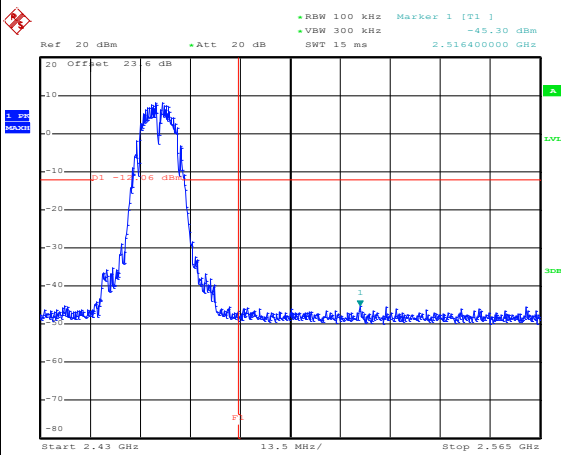

Date: 9.FEB.2016 12:03:14

Spurious Emission 30MHz~3GHz

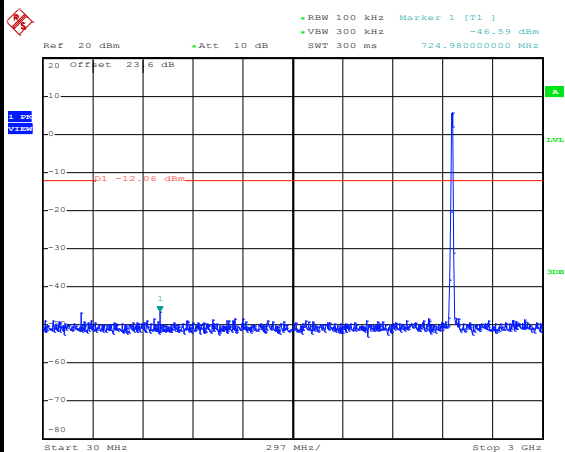

Date: 9.FEB.2016 12:03:30

Spurious Emission 2GHz~25GHz

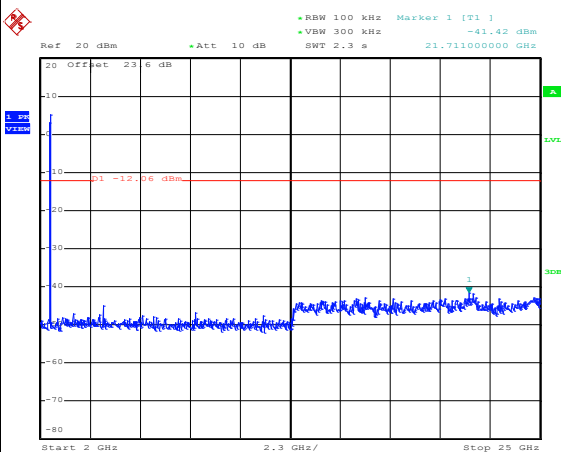

Date: 9.FEB.2016 12:03:39



Test Mode :	802.11g	Temperature :	21~25°C
Test Band :	2.4GHz Low	Relative Humidity :	51~54%
Test Channel :	01	Test Engineer :	Luffy Lin

WLAN 802.11g Channel 01

100kHz PSD reference Level

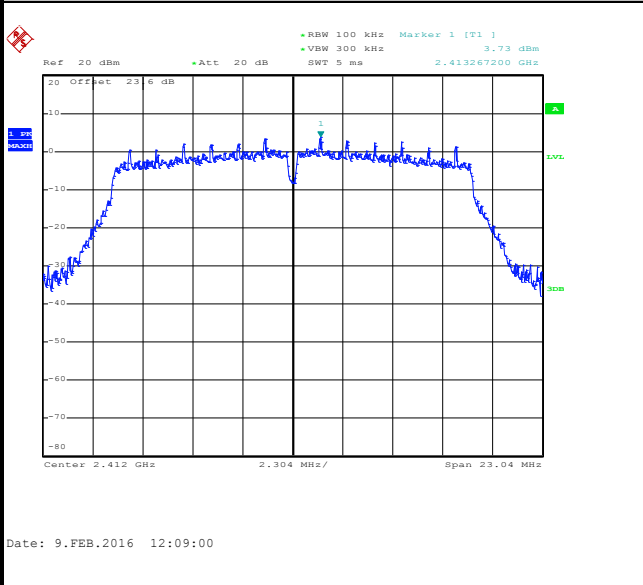

Low Channel Plot

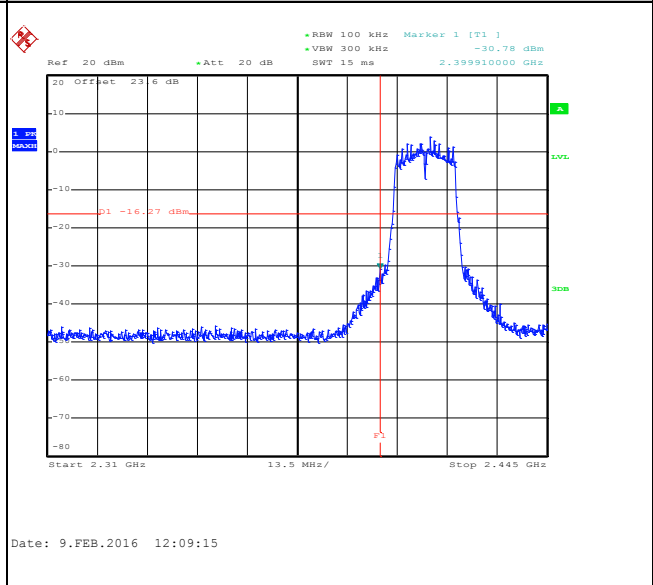

Spurious Emission 30MHz~3GHz

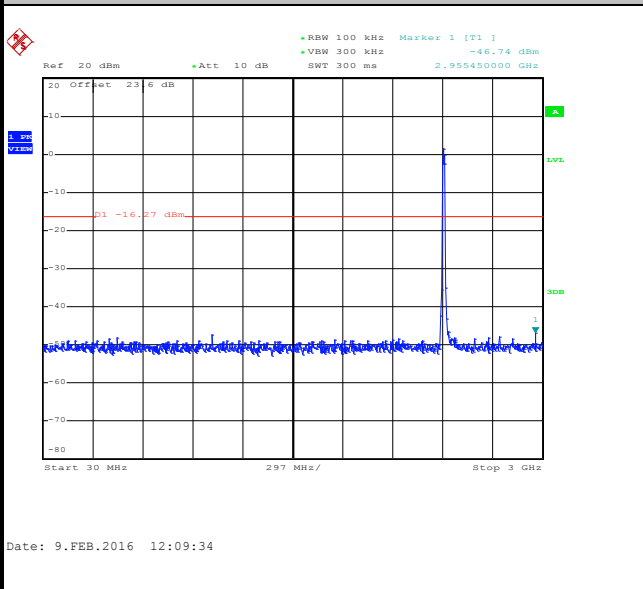

Spurious Emission 2GHz~25GHz

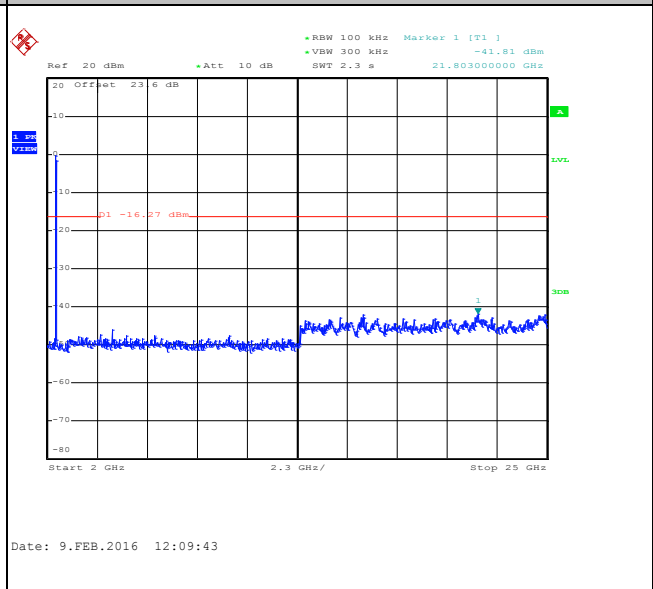



Test Mode :	802.11g	Temperature :	21~25°C
Test Band :	2.4GHz Mid	Relative Humidity :	51~54%
Test Channel :	06	Test Engineer :	Luffy Lin

WLAN 802.11g Channel 06

100kHz PSD reference Level

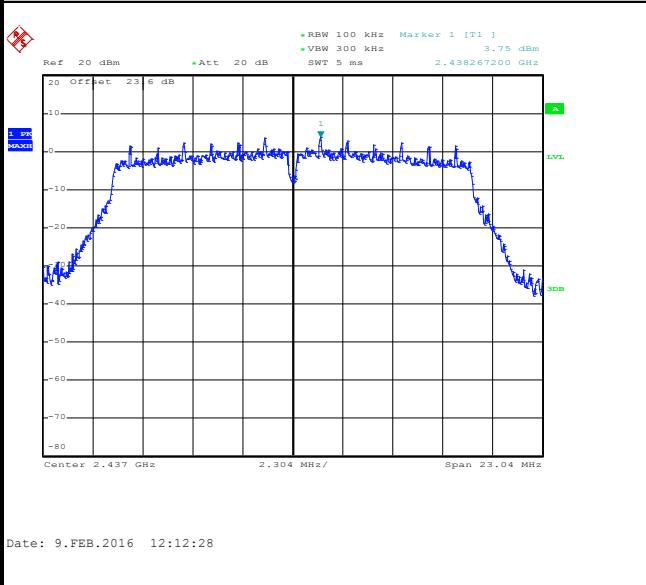

Spurious Emission 30MHz~3GHz

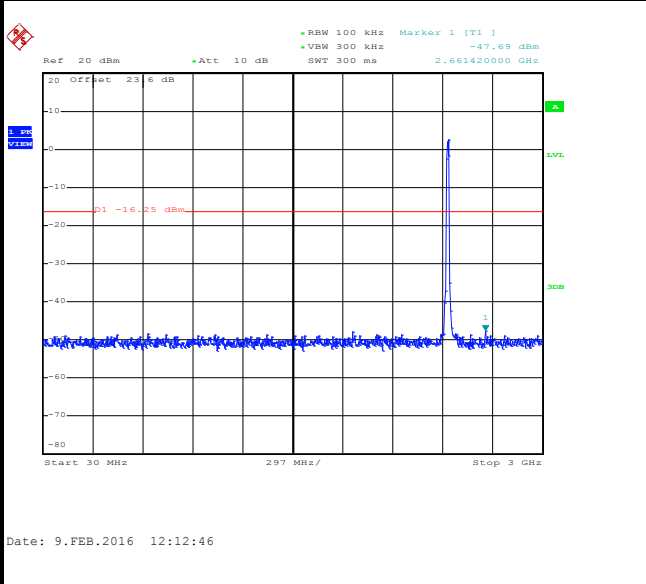

Spurious Emission 2GHz~25GHz

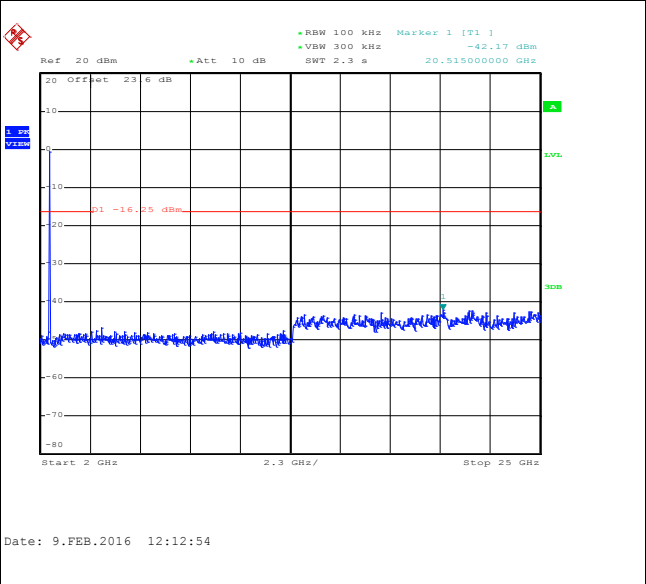



Test Mode :	802.11g	Temperature :	21~25°C
Test Band :	2.4GHz High	Relative Humidity :	51~54%
Test Channel :	11	Test Engineer :	Luffy Lin

WLAN 802.11g Channel 11

100kHz PSD reference Level

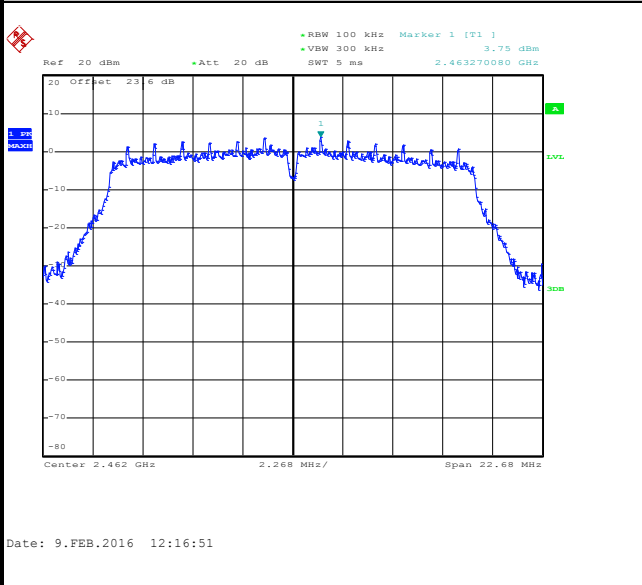

High Channel Plot

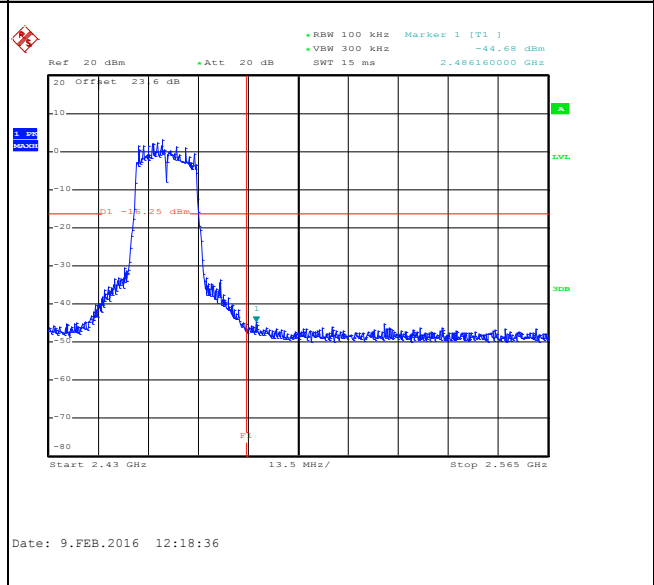

Spurious Emission 30MHz~3GHz

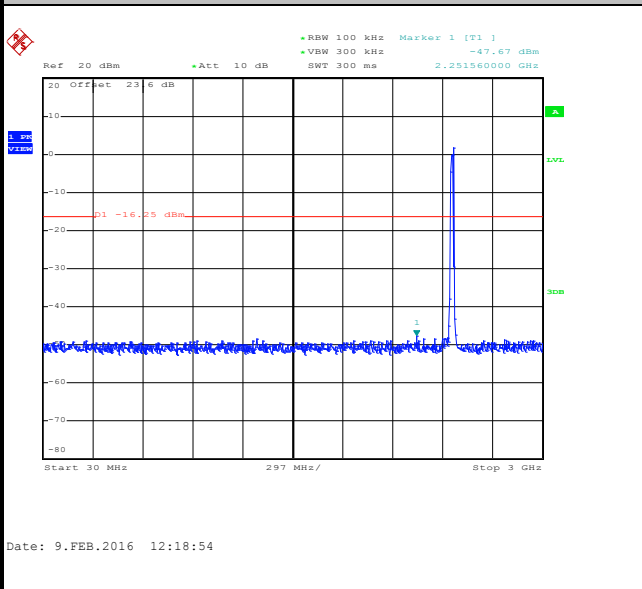

Spurious Emission 2GHz~25GHz

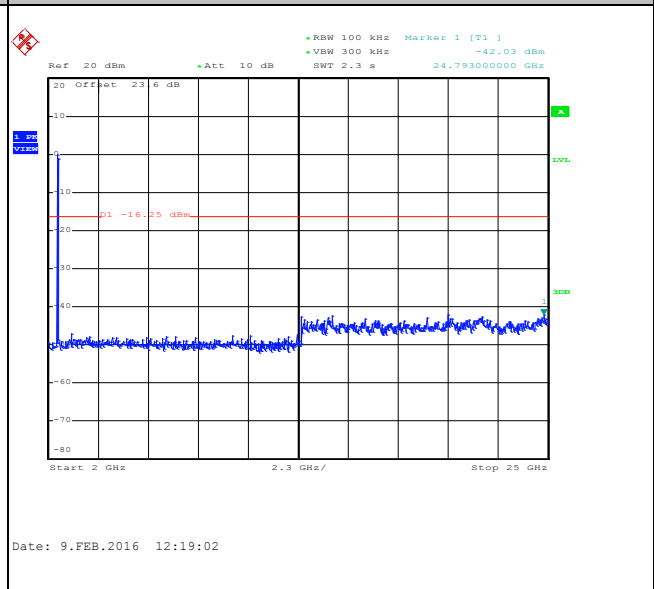



Test Mode :	802.11n HT20	Temperature :	21~25°C
Test Band :	2.4GHz Low	Relative Humidity :	51~54%
Test Channel :	01	Test Engineer :	Luffy Lin

WLAN 802.11n HT20 Channel 01

100kHz PSD reference Level

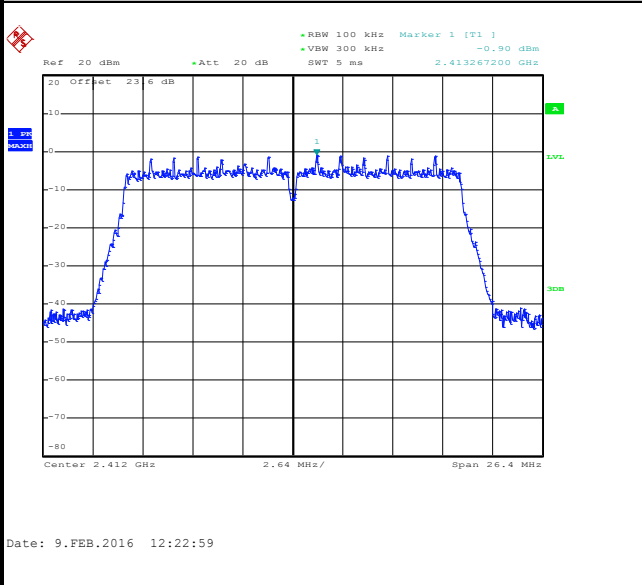

Low Channel Plot

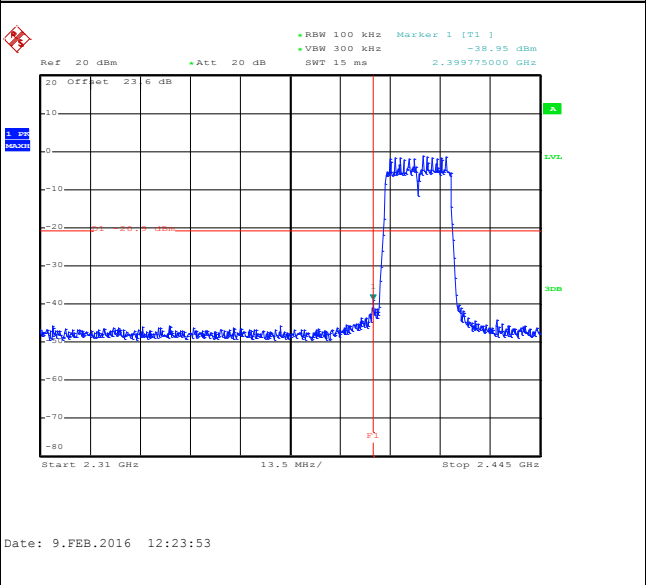

Spurious Emission 30MHz~3GHz

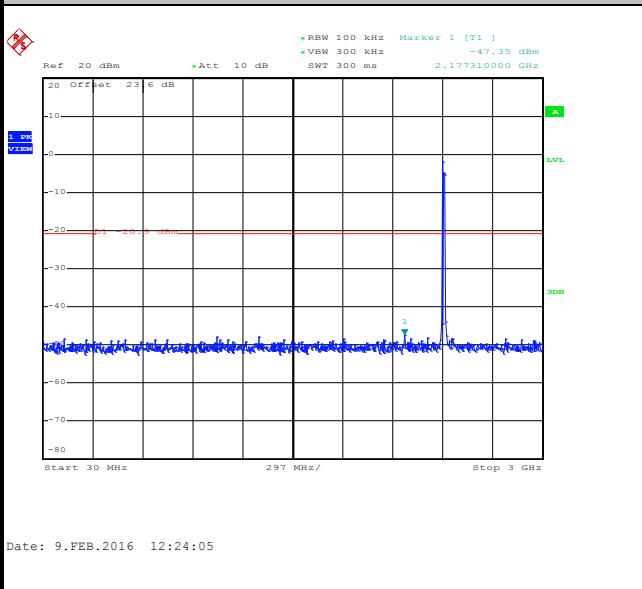

Spurious Emission 2GHz~25GHz

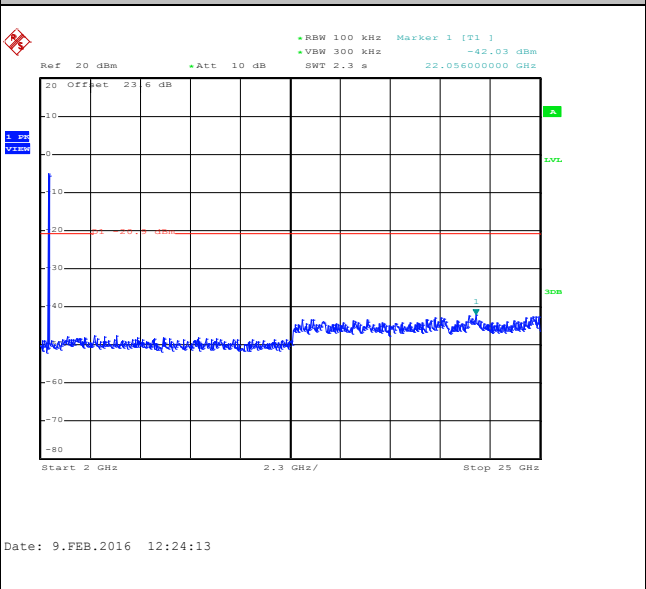



Test Mode :	802.11n HT20	Temperature :	21~25°C
Test Band :	2.4GHz Mid	Relative Humidity :	51~54%
Test Channel :	06	Test Engineer :	Luffy Lin

WLAN 802.11n HT20 Channel 06

100kHz PSD reference Level

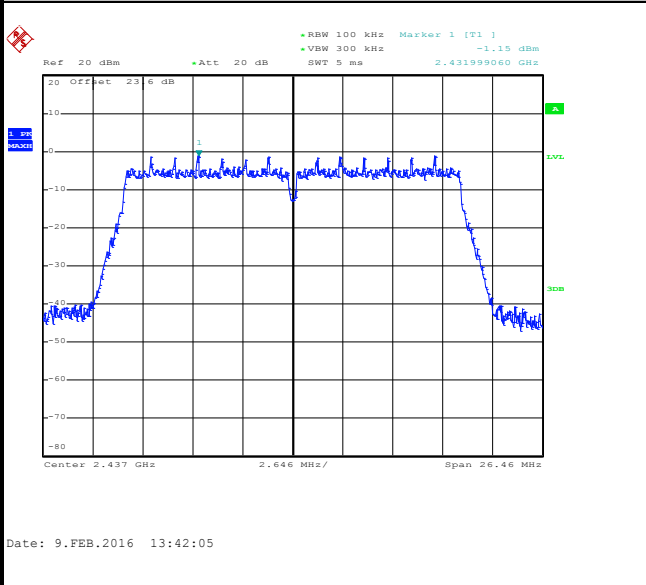

Spurious Emission 30MHz~3GHz

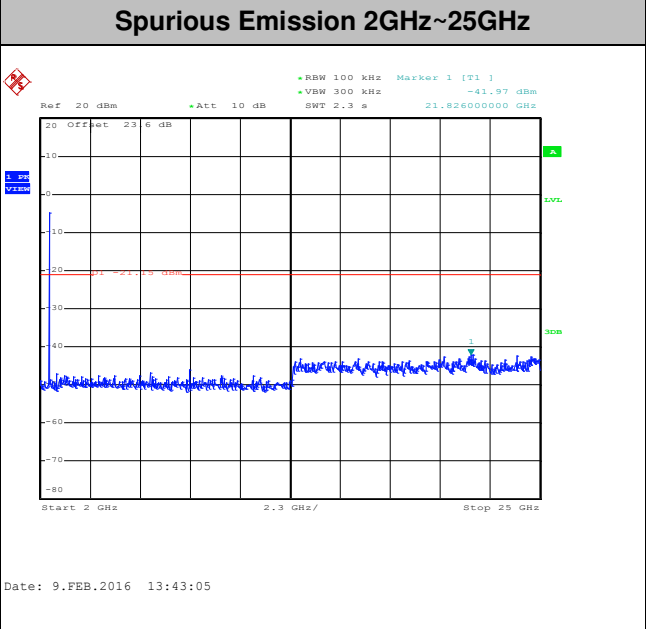
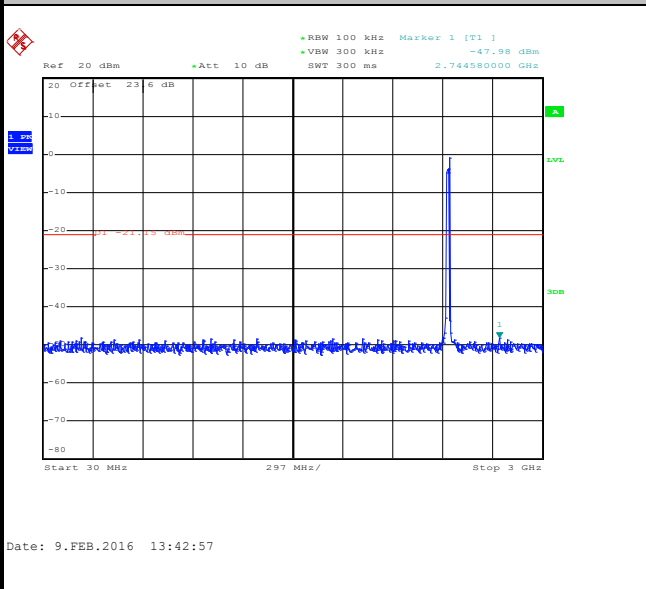



Test Mode :	802.11n HT20	Temperature :	21~25°C
Test Band :	2.4GHz High	Relative Humidity :	51~54%
Test Channel :	11	Test Engineer :	Luffy Lin

WLAN 802.11n HT20 Channel 11

100kHz PSD reference Level

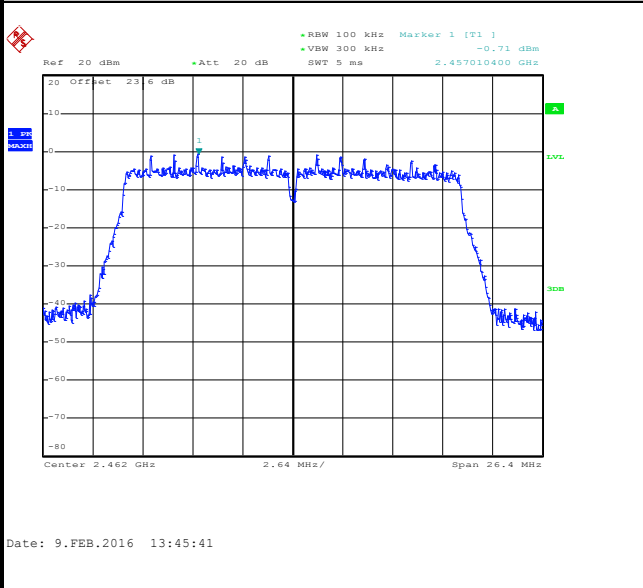

High Channel Plot

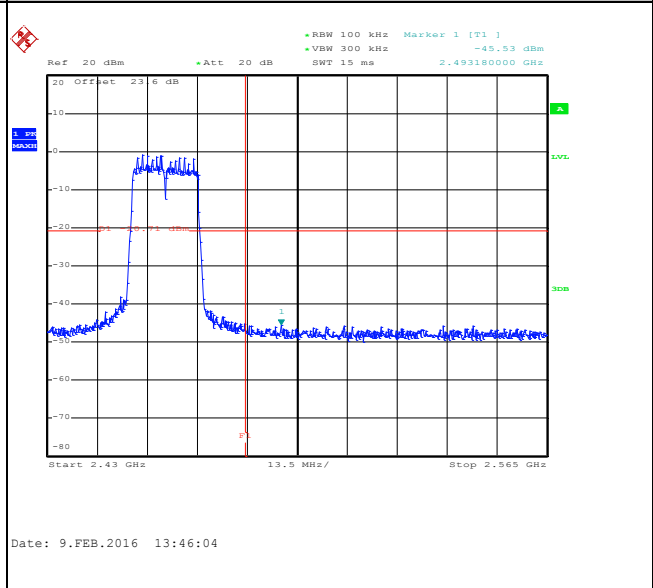

Spurious Emission 30MHz~3GHz

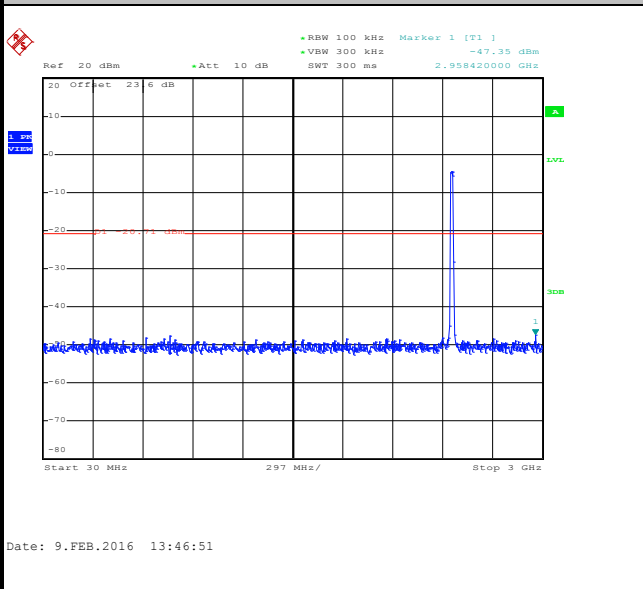

Spurious Emission 2GHz~25GHz

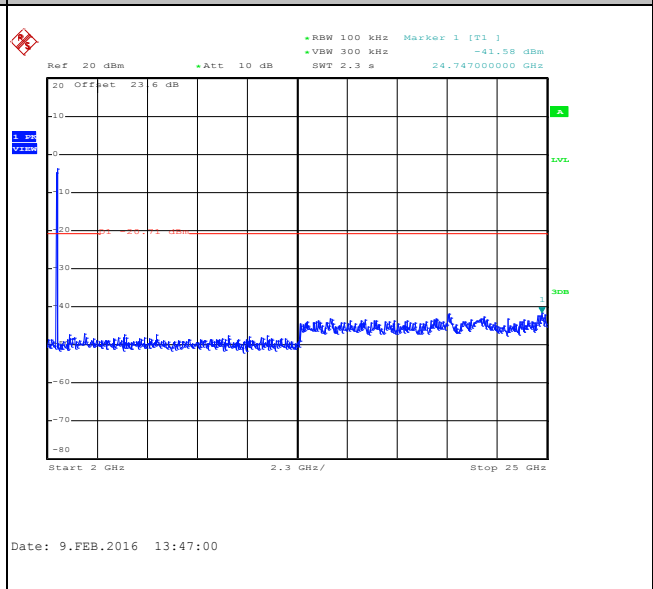



Test Mode :	802.11n HT40	Temperature :	21~25°C
Test Band :	2.4GHz Low	Relative Humidity :	51~54%
Test Channel :	03	Test Engineer :	Luffy Lin

WLAN 802.11n HT40 Channel 03

100kHz PSD reference Level

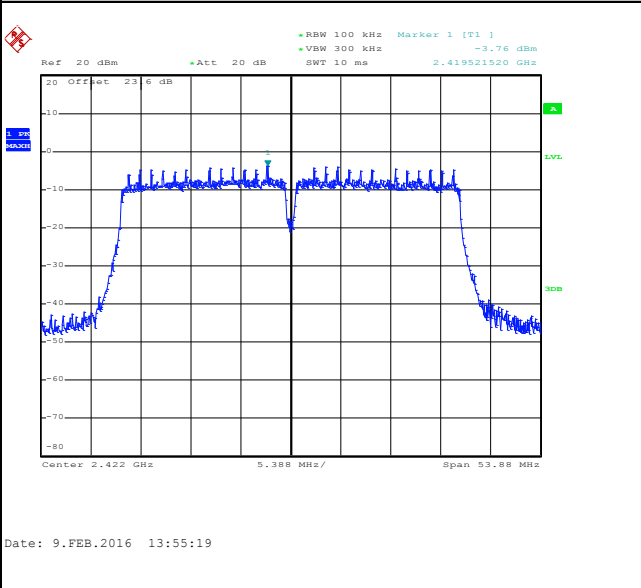

Low Channel Plot

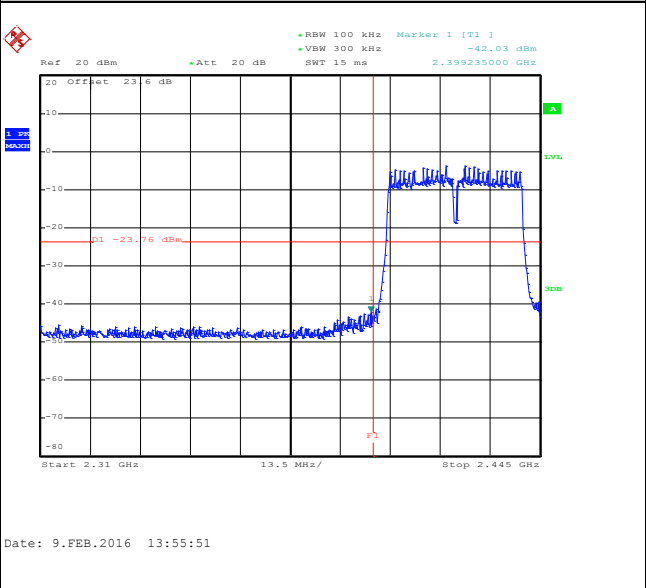

Spurious Emission 30MHz~3GHz

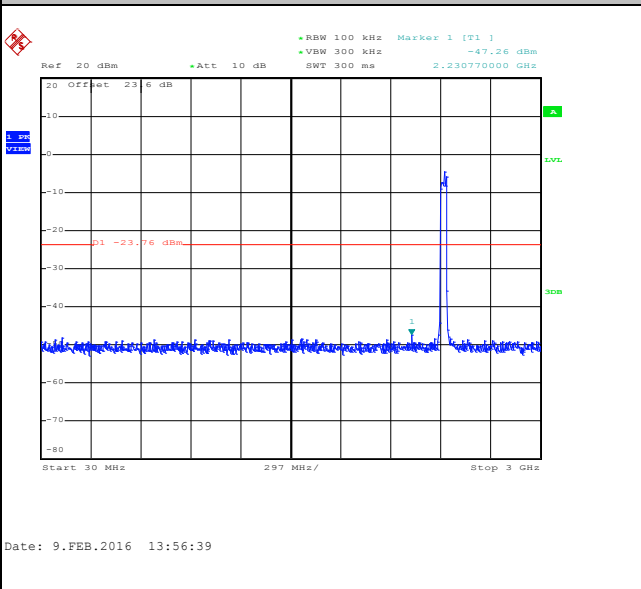

Spurious Emission 2GHz~25GHz

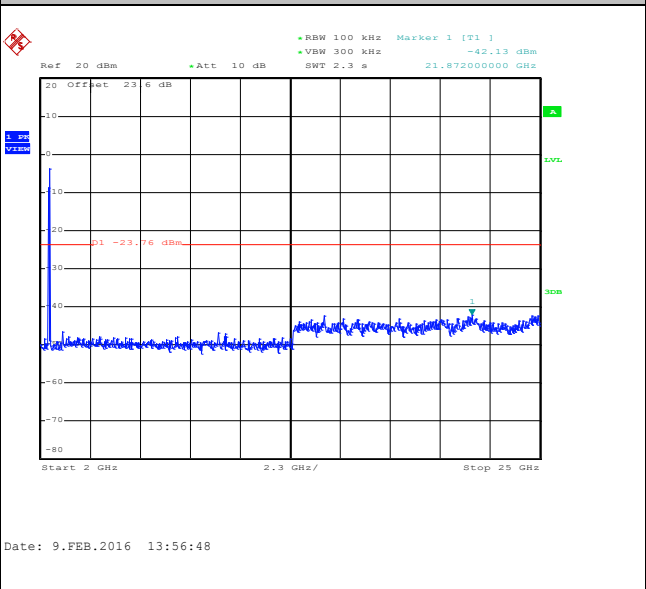



Test Mode :	802.11n HT40	Temperature :	21~25°C
Test Band :	2.4GHz Mid	Relative Humidity :	51~54%
Test Channel :	06	Test Engineer :	Luffy Lin

WLAN 802.11n HT40 Channel 06

100kHz PSD reference Level

Mid Channel Plot

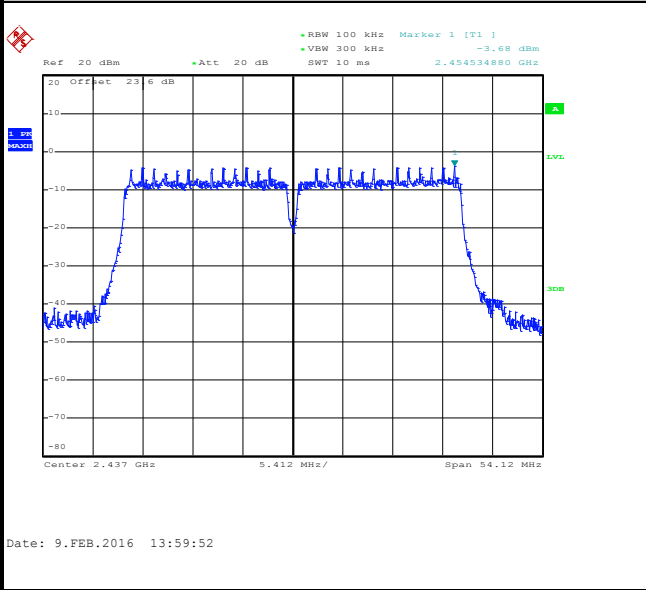

Spurious Emission 30MHz~3GHz

Spurious Emission 2GHz~25GHz

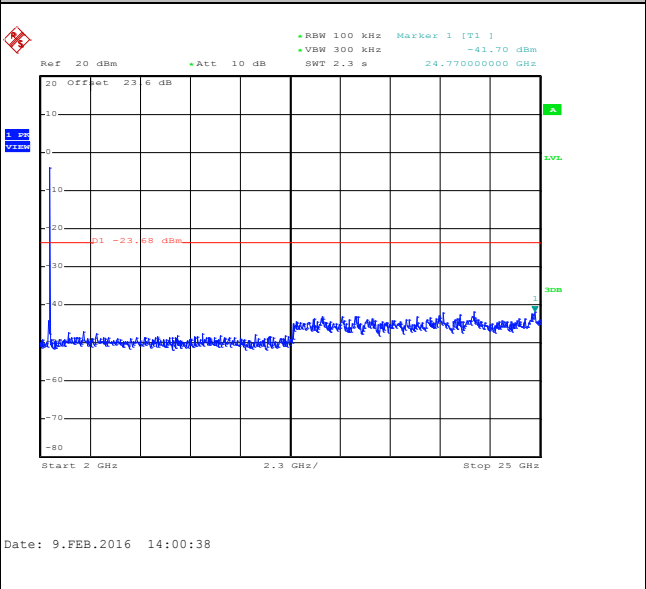
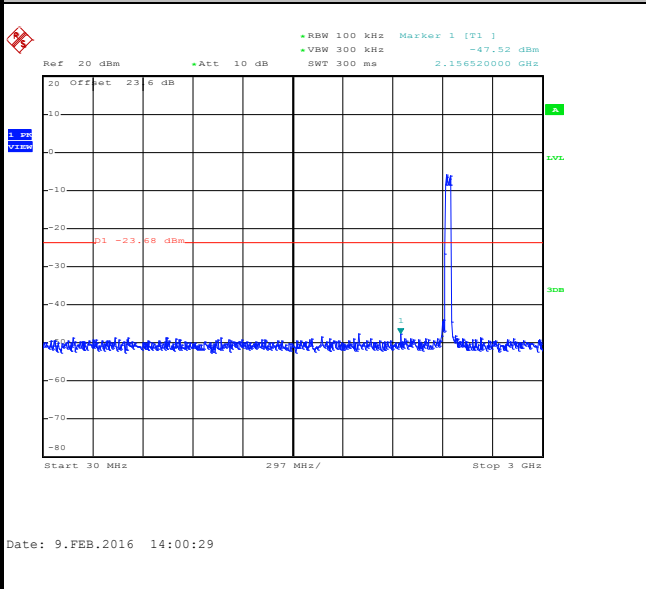



Test Mode :	802.11n HT40	Temperature :	21~25°C
Test Band :	2.4GHz High	Relative Humidity :	51~54%
Test Channel :	09	Test Engineer :	Luffy Lin

WLAN 802.11n HT40 Channel 09

100kHz PSD reference Level

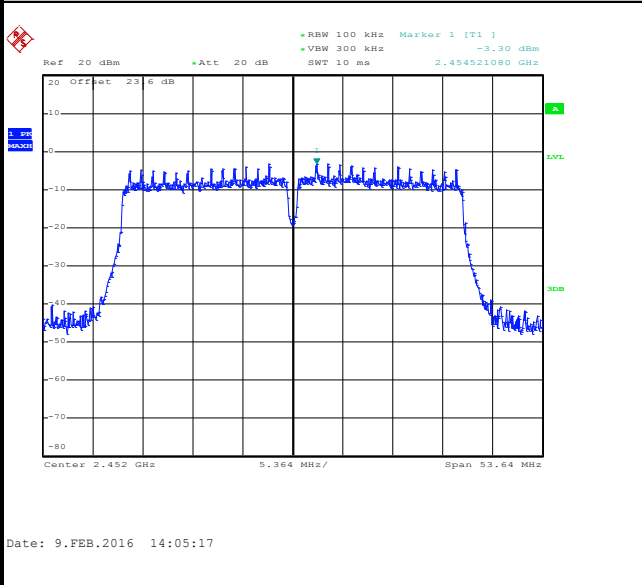

High Channel Plot

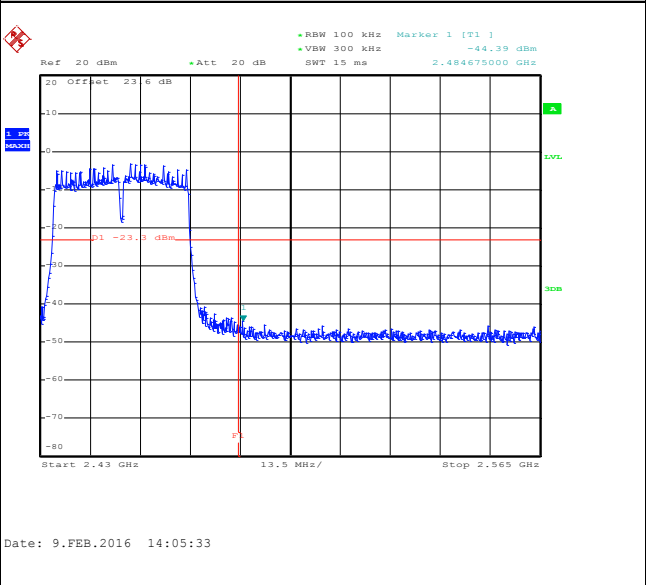

Spurious Emission 30MHz~3GHz

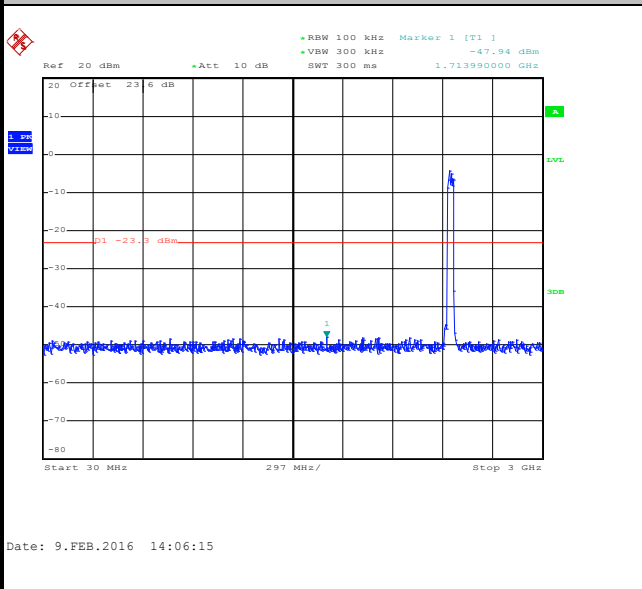

Spurious Emission 2GHz~25GHz

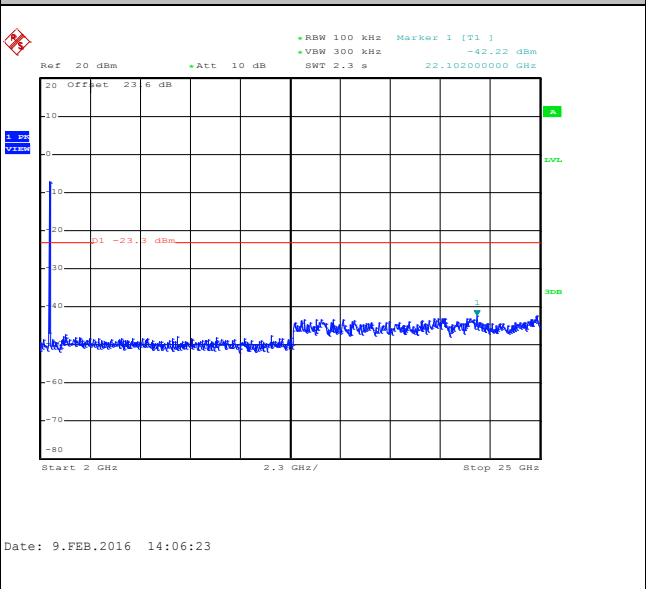



3.5 Radiated Band Edges and Spurious Emission Measurement

3.5.1 Limit of Radiated band edge and Spurious Emission Measurement

In any 100 kHz bandwidth outside the intentional radiator frequency band, all harmonics/spurious must be at least 20 dB below the highest emission level within the authorized band. If the output power of this device was measured by spectrum analyzer, the attenuation under this paragraph shall be 30 dB instead of 20 dB. In addition, radiated emissions which fall in the restricted bands must also comply with the FCC section 15.209 limits as below.

Frequency (MHz)	Field Strength (microvolts/meter)	Measurement Distance (meters)
0.009 – 0.490	2400/F(kHz)	300
0.490 – 1.705	24000/F(kHz)	30
1.705 – 30.0	30	30
30 – 88	100	3
88 – 216	150	3
216 - 960	200	3
Above 960	500	3

3.5.2 Measuring Instruments

The measuring equipment is listed in the section 4 of this test report.



3.5.3 Test Procedures

1. The testing follows FCC KDB Publication No. 558074 D01 DTS Meas. Guidance v03r05.
2. The EUT was arranged to its worst case and then tune the antenna tower (from 1 m to 4 m) and turntable (from 0 degree to 360 degrees) to find the maximum reading. A pre-amp and a high pass filter are used for the test in order to get better signal level.
3. The EUT was placed on a turntable with 0.8 meter for frequency below 1GHz and 1.5 meter for frequency above 1GHz respectively above ground.
4. The EUT was set 3 meters from the interference receiving antenna, which was mounted on the top of a variable height antenna tower.
5. Corrected Reading: Antenna Factor + Cable Loss + Read Level - Preamp Factor = Level
6. For measurement below 1GHz, If the emission level of the EUT measured by the peak detector is 3 dB lower than the applicable limit, the peak emission level will be reported. Otherwise, the emission measurement will be repeated using the quasi-peak detector and reported.
7. Use the following spectrum analyzer settings:
 - (1) Span shall wide enough to fully capture the emission being measured;
 - (2) Set RBW=100 kHz for $f < 1 \text{ GHz}$; $\text{VBW} \geq \text{RBW}$; Sweep = auto; Detector function = peak; Trace = max hold;
 - (3) Set RBW = 1 MHz, VBW= 3MHz for $f \geq 1 \text{ GHz}$ for peak measurement.

For average measurement:

 - $\text{VBW} = 10 \text{ Hz}$, when duty cycle is no less than 98 percent.
 - $\text{VBW} \geq 1/T$, when duty cycle is less than 98 percent where T is the minimum transmission duration over which the transmitter is on and is transmitting at its maximum power control level for the tested mode of operation.

Band	Duty Cycle(%)	T(μs)	1/T(kHz)	VBW Setting
802.11b	100.00	-	-	10Hz
802.11g	97.20	1390	0.72	1kHz
2.4GHz 802.11n HT20	97.02	1300	0.77	1kHz
2.4GHz 802.11n HT40	94.71	644	1.55	3kHz

3.5.4 Test Setup

For radiated emissions below 30MHz

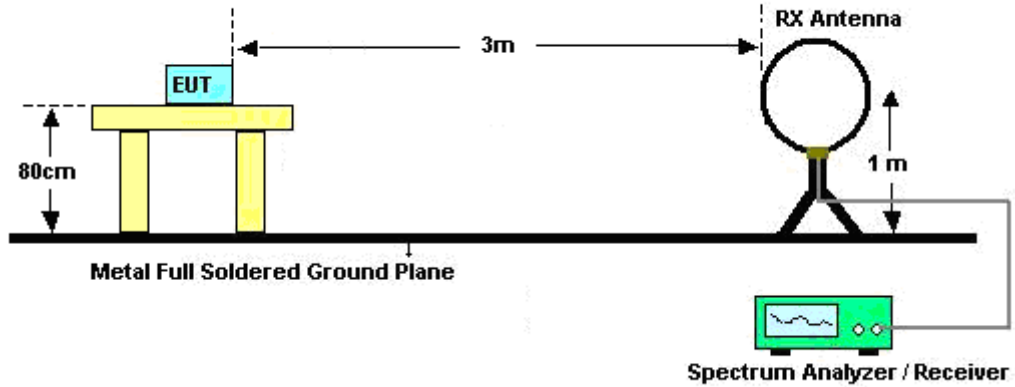

For radiated emissions from 30MHz to 1GHz

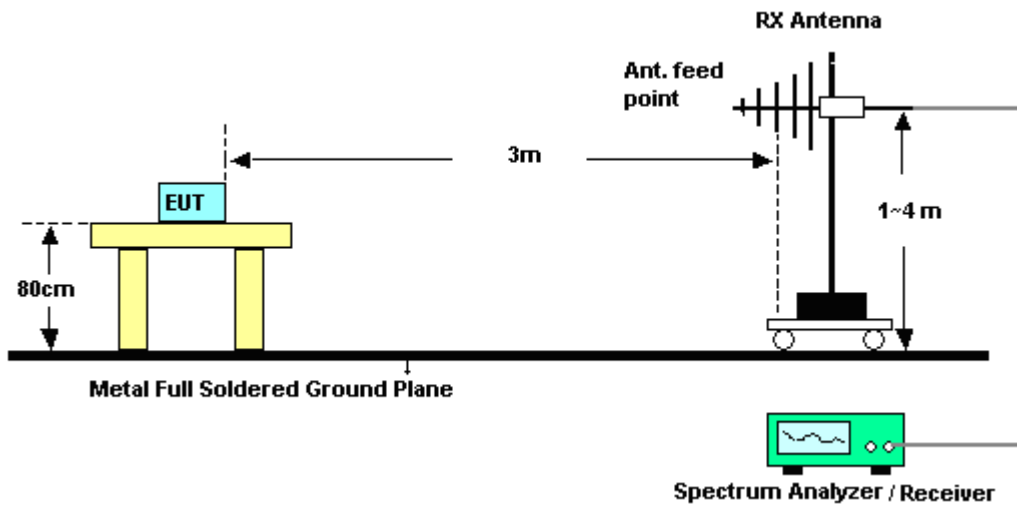

For radiated emissions above 1GHz

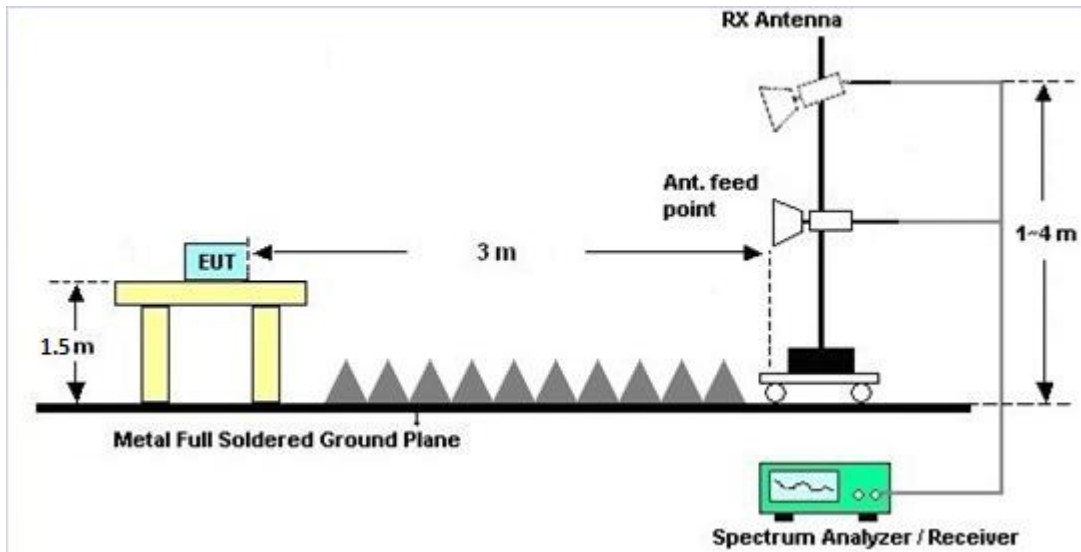

3.5.5 Test Results of Radiated Spurious Emissions (9kHz ~ 30MHz)

The low frequency, which started from 9 kHz to 30MHz, was pre-scanned and the result which was 20dB lower than the limit line per 15.31(o) was not reported.

3.5.6 Test Result of Radiated Spurious at Band Edges

Please refer to Appendix B and C.

3.5.7 Test Result of Radiated Spurious Emission (30MHz ~ 10th Harmonic)

Please refer to Appendix B and C.



3.5.8 Duty Cycle

802.11b

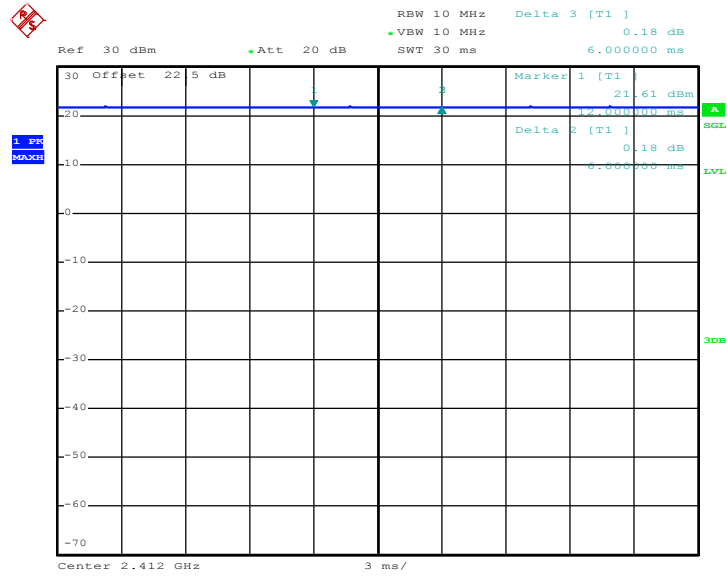

Date: 5.FEB.2016 17:39:28

802.11g

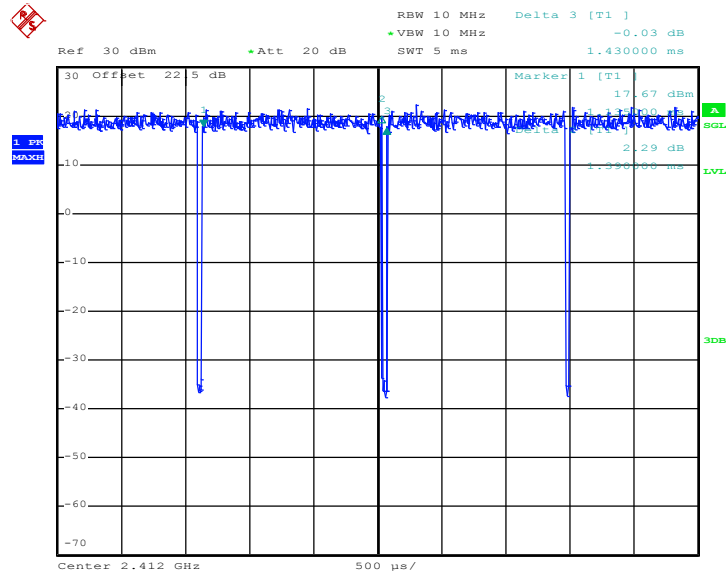

Date: 5.FEB.2016 17:42:59



802.11n HT20

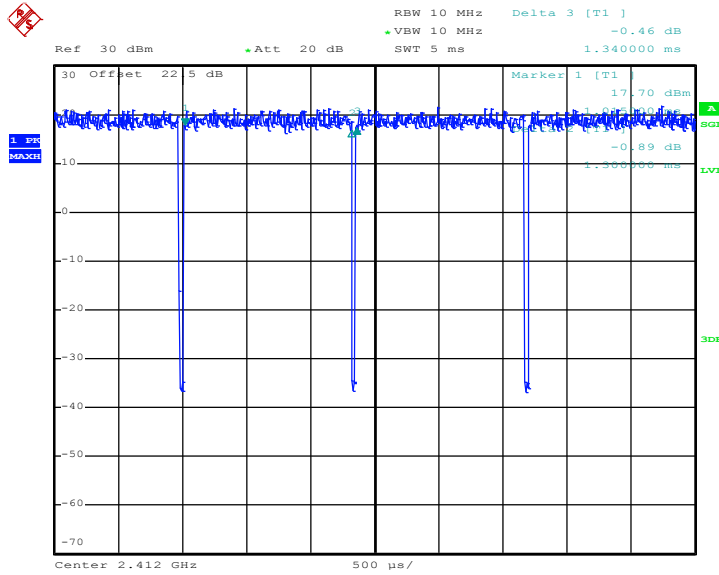

Date: 5.FEB.2016 17:52:58

802.11n HT40

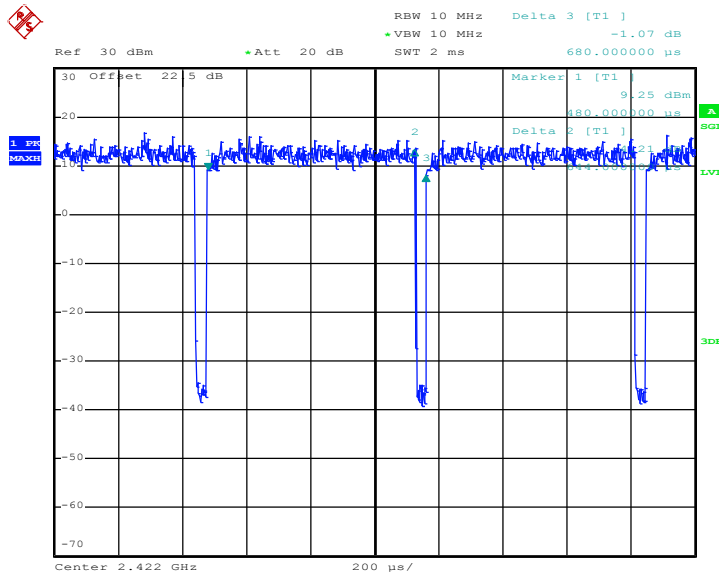

Date: 5.FEB.2016 18:05:54



3.6 AC Conducted Emission Measurement

3.6.1 Limit of AC Conducted Emission

For equipment that is designed to be connected to the public utility (AC) power line, the radio frequency voltage that is conducted back onto the AC power line on any frequency or frequencies within the band 150 kHz to 30 MHz shall not exceed the limits in the following table.

Frequency of Emission (MHz)	Conducted Limit (dBµV)	
	Quasi-Peak	Average
0.15-0.5	66 to 56*	56 to 46*
0.5-5	56	46
5-30	60	50

*Decreases with the logarithm of the frequency.

3.6.2 Measuring Instruments

The measuring equipment is listed in the section 4 of this test report.

3.6.3 Test Procedures

1. The EUT was placed 0.4 meter from the conducting wall of the shielding room, and it was kept at least 80 centimeters from any other grounded conducting surface.
2. Connect EUT to the power mains through a line impedance stabilization network (LISN).
3. All the support units are connecting to the other LISN.
4. The LISN provides 50 ohm coupling impedance for the measuring instrument.
5. The FCC states that a 50 ohm, 50 microhenry LISN should be used.
6. Both sides of AC line were checked for maximum conducted interference.
7. The frequency range from 150 kHz to 30 MHz was searched.
8. Set the test-receiver system to Peak Detect Function and specified bandwidth (IF bandwidth = 9kHz) with Maximum Hold Mode.

3.6.4 Test Setup

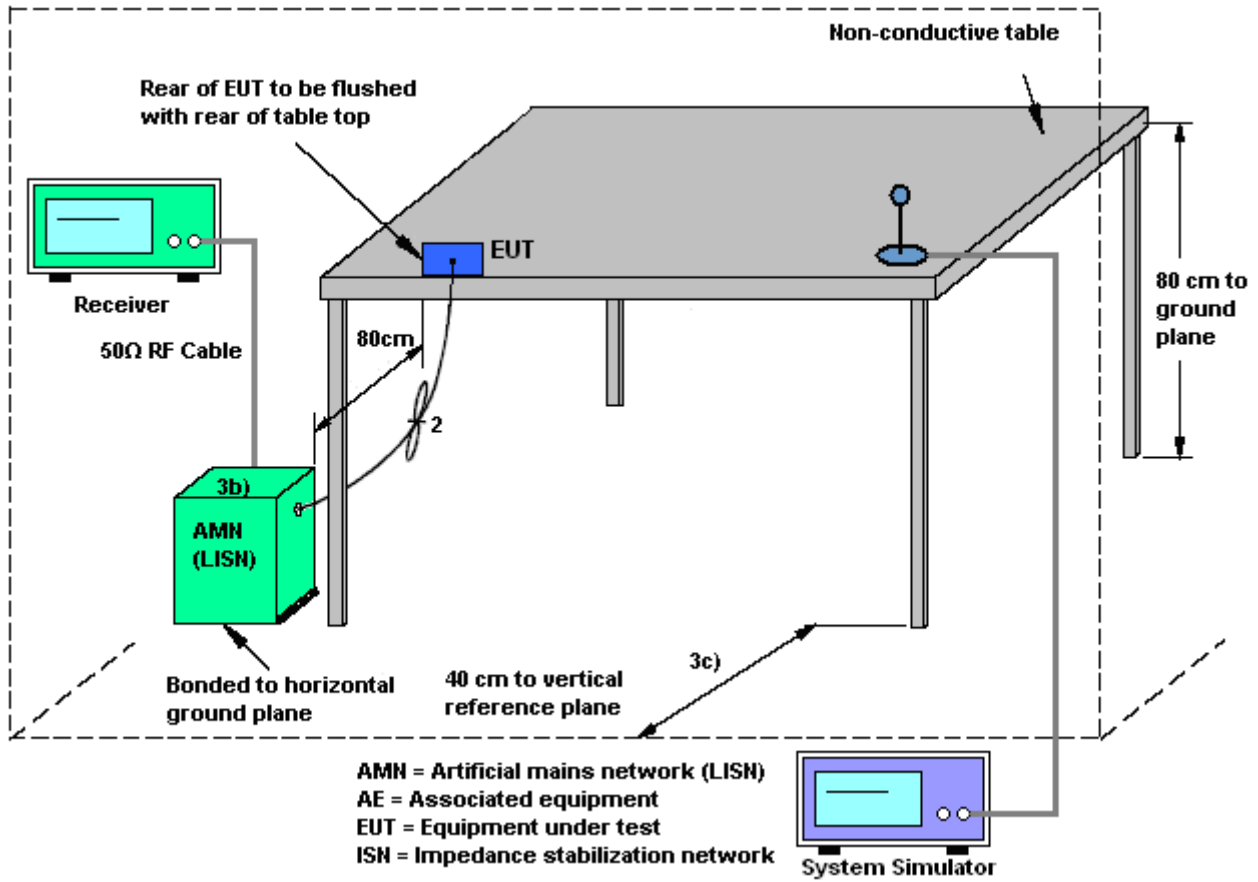



3.6.5 Test Result of AC Conducted Emission

Test Mode :	Mode 1	Temperature :	23~24°C
Test Engineer :	Kai-Chun Chu	Relative Humidity :	48~49%
Test Voltage :	120Vac / 60Hz	Phase :	Line
Function Type :	GSM1900 Idle + Bluetooth Link + WLAN (2.4GHz) Link + Camera + Earphone + USB Cable (Charging from Adapter)		

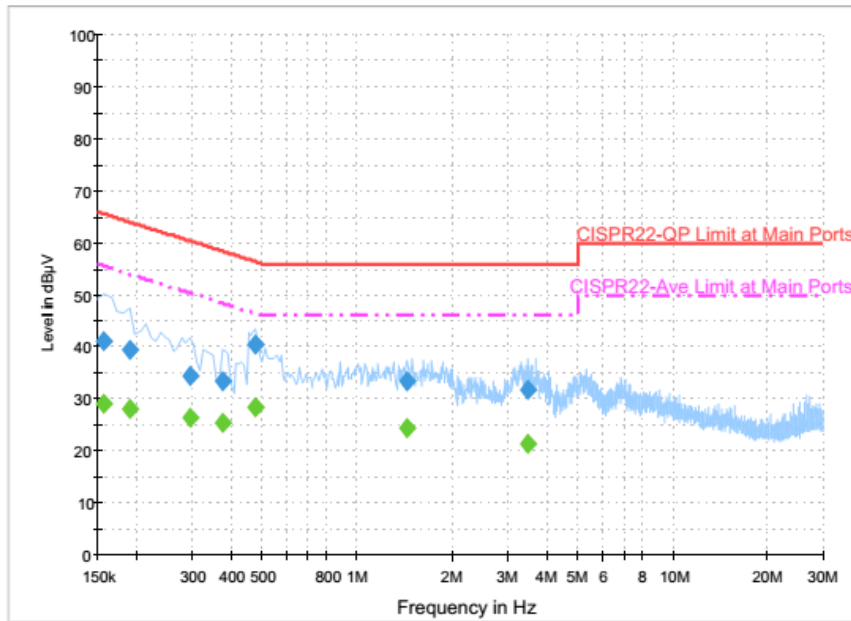

Final Result : Quasi-Peak

Frequency (MHz)	Quasi-Peak (dBµV)	Filter	Line	Corr. (dB)	Margin (dB)	Limit (dBµV)
0.158000	41.3	Off	L1	19.6	24.3	65.6
0.190000	39.5	Off	L1	19.6	24.5	64.0
0.294000	34.5	Off	L1	19.6	25.9	60.4
0.374000	33.4	Off	L1	19.6	25.0	58.4
0.478000	40.5	Off	L1	19.6	15.9	56.4
1.446000	33.3	Off	L1	19.6	22.7	56.0
3.494000	31.7	Off	L1	19.6	24.3	56.0

Final Result : Average

Frequency (MHz)	Average (dBµV)	Filter	Line	Corr. (dB)	Margin (dB)	Limit (dBµV)
0.158000	29.0	Off	L1	19.6	26.6	55.6
0.190000	28.0	Off	L1	19.6	26.0	54.0
0.294000	26.4	Off	L1	19.6	24.0	50.4
0.374000	25.5	Off	L1	19.6	22.9	48.4
0.478000	28.5	Off	L1	19.6	17.9	46.4
1.446000	24.5	Off	L1	19.6	21.5	46.0
3.494000	21.4	Off	L1	19.6	24.6	46.0



Test Mode :	Mode 1	Temperature :	23~24°C
Test Engineer :	Kai-Chun Chu	Relative Humidity :	48~49%
Test Voltage :	120Vac / 60Hz	Phase :	Neutral
Function Type :	GSM1900 Idle + Bluetooth Link + WLAN (2.4GHz) Link + Camera + Earphone + USB Cable (Charging from Adapter)		

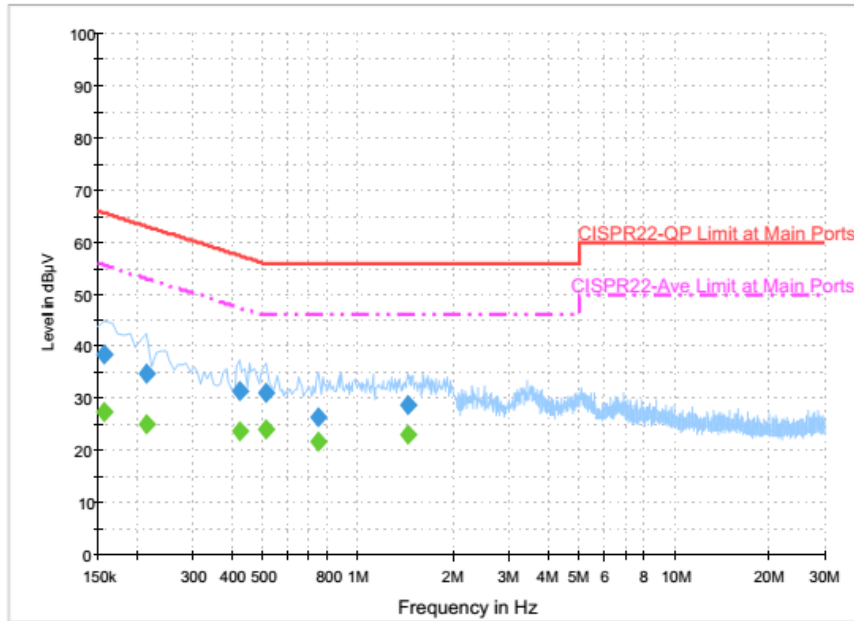

Final Result : Quasi-Peak

Frequency (MHz)	Quasi-Peak (dBµV)	Filter	Line	Corr. (dB)	Margin (dB)	Limit (dBµV)
0.158000	38.5	Off	N	19.6	27.1	65.6
0.214000	34.7	Off	N	19.6	28.3	63.0
0.422000	31.4	Off	N	19.6	26.0	57.4
0.510000	31.1	Off	N	19.6	24.9	56.0
0.750000	26.4	Off	N	19.6	29.6	56.0
1.438000	28.7	Off	N	19.6	27.3	56.0

Final Result : Average

Frequency (MHz)	Average (dBµV)	Filter	Line	Corr. (dB)	Margin (dB)	Limit (dBµV)
0.158000	27.4	Off	N	19.6	28.2	55.6
0.214000	25.2	Off	N	19.6	27.8	53.0
0.422000	23.7	Off	N	19.6	23.7	47.4
0.510000	24.1	Off	N	19.6	21.9	46.0
0.750000	21.8	Off	N	19.6	24.2	46.0
1.438000	23.1	Off	N	19.6	22.9	46.0



3.7 Antenna Requirements

3.7.1 Standard Applicable

If directional gain of transmitting antennas is greater than 6dBi, the power shall be reduced by the same level in dB comparing to gain minus 6dBi. For the fixed point-to-point operation, the power shall be reduced by one dB for every 3 dB that the directional gain of the antenna exceeds 6 dBi. The use of a permanently attached antenna or of an antenna that uses a unique coupling to the intentional radiator shall be considered sufficient to comply with the FCC rule.

3.7.2 Antenna Anti-Replacement Construction

An embedded-in antenna design is used.

3.7.3 Antenna Gain

The antenna peak gain of EUT is less than 6 dBi. Therefore, it is not necessary to reduce maximum peak output power limit.



4 List of Measuring Equipment

Instrument	Manufacturer	Model No.	Serial No.	Characteristics	Calibration Date	Test Date	Due Date	Remark
Hygrometer	Testo	608-H2	41410069	N/A	Aug. 27, 2015	Feb. 05, 2016 ~ Feb. 11, 2016	Aug. 26, 2016	Conducted (TH05-HY)
Power Meter	Anritsu	ML2495A	1132003	300MHz~40GHz	Aug. 12, 2015	Feb. 05, 2016 ~ Feb. 11, 2016	Aug. 11, 2016	Conducted (TH05-HY)
Power Sensor	Anritsu	MA2411B	1126017	300MHz~40GHz	Aug. 12, 2015	Feb. 05, 2016 ~ Feb. 11, 2016	Aug. 11, 2016	Conducted (TH05-HY)
Spectrum Analyzer	Rohde & Schwarz	FSP40	100057	9kHz-40GHz	Nov. 23, 2015	Feb. 05, 2016 ~ Feb. 11, 2016	Nov. 22, 2016	Conducted (TH05-HY)
RF Cable	JYEBAO	K30K30-5003- 1.5M40	N/A	0.1MHz~40GHz	Mar. 18, 2015	Feb. 05, 2016 ~ Feb. 11, 2016	Mar. 17, 2016	Conducted (TH05-HY)
AC Power Source	ChainTek	APC-1000W	N/A	N/A	N/A	Feb. 22, 2016	N/A	Conduction (CO05-HY)
EMI Test Receiver	Rohde & Schwarz	ESCI 7	100724	9kHz~7GHz	Aug. 26, 2015	Feb. 22, 2016	Aug. 25, 2016	Conduction (CO05-HY)
Hygrometer	Testo	608-H1	34913912	N/A	Apr. 20, 2015	Feb. 22, 2016	Apr. 19, 2016	Conduction (CO05-HY)
LISN	Rohde & Schwarz	ENV216	100080	9kHz~30MHz	Dec. 02, 2015	Feb. 22, 2016	Dec. 01, 2016	Conduction (CO05-HY)
LF Cable	HUBER + SUHNER	RG-214/U	LF01	N/A	Jan. 06, 2016	Feb. 22, 2016	Jan. 05, 2017	Conduction (CO05-HY)
Test Software	N/A	EMC32	8.40.0	N/A	N/A	Feb. 22, 2016	N/A	Conduction (CO05-HY)



Instrument	Manufacturer	Model No.	Serial No.	Characteristics	Calibration Date	Test Date	Due Date	Remark
Bilog Antenna	TESEQ	CBL 6111D	35419	30MHz to 1GHz	Jan. 13, 2016	Feb. 23, 2016 ~ Feb. 26, 2016	Jan. 12, 2017	Radiation (03CH07-HY)
Double Ridge Horn Antenna	ESCO	3117	00075962	1GHz ~ 18GHz	Aug. 21, 2015	Feb. 23, 2016 ~ Feb. 26, 2016	Aug. 20, 2016	Radiation (03CH07-HY)
SHF-EHF Horn Antenna	SCHWARZBECK	BBHA 9170	BBHA91702 51	18GHz- 40GHz	Oct. 12, 2015	Feb. 23, 2016 ~ Feb. 26, 2016	Oct. 11, 2016	Radiation (03CH07-HY)
Loop Antenna	Rohde & Schwarz	HFH2-Z2	100315	9 kHz~30 MHz	Sep. 02, 2015	Feb. 23, 2016 ~ Feb. 26, 2016	Sep. 01, 2016	Radiation (03CH07-HY)
Hygrometer	Testo	608-H1	34897197	N/A	May 04, 2015	Feb. 23, 2016 ~ Feb. 26, 2016	May 03, 2016	Radiation (03CH07-HY)
Preamplifier	MITEQ	AMF-7D-00101 800-30-10P	1590075	1GHz ~ 18GHz	Apr. 20, 2015	Feb. 23, 2016 ~ Feb. 26, 2016	Apr. 19, 2016	Radiation (03CH07-HY)
Preamplifier	COM-POWER	PA-103A	161241	10MHz-1000MHz	Mar. 12, 2015	Feb. 23, 2016 ~ Feb. 26, 2016	Mar. 11, 2016	Radiation (03CH07-HY)
Preamplifier	Agilent	8449B	3008A02362	1GHz~ 26.5GHz	Oct. 19, 2015	Feb. 23, 2016 ~ Feb. 26, 2016	Oct. 18, 2016	Radiation (03CH07-HY)
Preamplifier	MITEQ	JS44-18004000 -33-8P	1840917	18GHz ~ 40GHz	Jun. 02, 2015	Feb. 23, 2016 ~ Feb. 26, 2016	Jun. 01, 2016	Radiation (03CH07-HY)
Spectrum Analyzer	Agilent	N9010A	MY53470118	10Hz~44GHz	Mar. 03, 2015	Feb. 23, 2016 ~ Feb. 26, 2016	Mar. 02, 2016	Radiation (03CH07-HY)
Controller	ChainTek	Chaintek 3000	N/A	Control Turn table	N/A	Feb. 23, 2016 ~ Feb. 26, 2016	N/A	Radiation (03CH07-HY)
Controller	Max-Full	MF7802	MF78020836 8	Control Ant Mast	N/A	Feb. 23, 2016 ~ Feb. 26, 2016	N/A	Radiation (03CH07-HY)
Antenna Mast	Max-Full	MFA520BS	N/A	1m~4m	N/A	Feb. 23, 2016 ~ Feb. 26, 2016	N/A	Radiation (03CH07-HY)
Turn Table	ChainTek	Chaintek 3000	N/A	0~360 degree	N/A	Feb. 23, 2016 ~ Feb. 26, 2016	N/A	Radiation (03CH07-HY)
RF Cable	HUBER + SUHNER	SUCOFLEX 104	MY84209521	9KHz~40GHz	Dec. 03, 2015	Feb. 23, 2016 ~ Feb. 26, 2016	Dec. 02, 2016	Radiation (03CH07-HY)
EMI Test Receiver	Agilent Technologies	N9038A(MXE)	MY53290045	20MHz~8.4GHz	Feb. 01, 2016	Feb. 23, 2016 ~ Feb. 26, 2016	Jan. 31, 2017	Radiation (03CH07-HY)
Test Software	N/A	E3	6.2009-8-24 (sporton)	N/A	N/A	Feb. 23, 2016 ~ Feb. 26, 2016	N/A	Radiation (03CH07-HY)
Filter	Wainwright	WLKS1200-8SS	SN3	1.2G Low Pass	Oct. 01, 2015	Feb. 23, 2016 ~ Feb. 26, 2016	Sep. 30, 2016	Radiation (03CH07-HY)
Filter	Microwave	H3G018G1	SN477220	3.0G High Pass	Oct. 01, 2015	Feb. 23, 2016 ~ Feb. 26, 2016	Sep. 30, 2016	Radiation (03CH07-HY)



5 Uncertainty of Evaluation

Uncertainty of Conducted Emission Measurement (150kHz ~ 30MHz)

Measuring Uncertainty for a Level of Confidence of 95% ($U = 2Uc(y)$)	2.26
---	------

Uncertainty of Radiated Emission Measurement (30 MHz ~ 1000 MHz)

Measuring Uncertainty for a Level of Confidence of 95% ($U = 2Uc(y)$)	5.60
---	------



Appendix A. Conducted Test Results

A1 - DTS Part

Test Engineer:	Luffy Lin	Temperature:	21~25	°C
Test Date:	2016/02/05 ~ 2016/02/11	Relative Humidity:	51~54	%

TEST RESULTS DATA
6dB and 99% Occupied Bandwidth

2.4GHz Band								
Mod.	Data Rate	N _{TX}	CH.	Freq. (MHz)	99% Occupied BW (MHz)	6dB BW (MHz)	6dB BW Limit (MHz)	Pass/Fail
11b	1Mbps	1	1	2412	12.40	9.52	0.50	Pass
11b	1Mbps	1	6	2437	12.55	9.60	0.50	Pass
11b	1Mbps	1	11	2462	12.50	9.60	0.50	Pass
11g	6Mbps	1	1	2412	17.40	15.36	0.50	Pass
11g	6Mbps	1	6	2437	17.30	15.36	0.50	Pass
11g	6Mbps	1	11	2462	17.45	15.12	0.50	Pass
HT20	MCS0	1	1	2412	18.60	17.60	0.50	Pass
HT20	MCS0	1	6	2437	18.60	17.64	0.50	Pass
HT20	MCS0	1	11	2462	18.50	17.60	0.50	Pass
HT40	MCS0	1	3	2422	36.40	35.92	0.50	Pass
HT40	MCS0	1	6	2437	36.70	36.08	0.50	Pass
HT40	MCS0	1	9	2452	36.30	35.76	0.50	Pass

TEST RESULTS DATA
Peak Power Table

2.4GHz Band										
Mod.	Data Rate	N _{TX}	CH.	Freq. (MHz)	Peak Conducted Power (dBm)	Conducted Power Limit (dBm)	DG (dBi)	EIRP Power (dBm)	EIRP Power Limit (dBm)	Pass /Fail
11b	1Mbps	1	1	2412	20.83	30.00	-2.00	18.83	36.00	Pass
11b	1Mbps	1	6	2437	20.99	30.00	-2.00	18.99	36.00	Pass
11b	1Mbps	1	11	2462	20.53	30.00	-2.00	18.53	36.00	Pass
11g	6Mbps	1	1	2412	23.53	30.00	-2.00	21.53	36.00	Pass
11g	6Mbps	1	6	2437	23.79	30.00	-2.00	21.79	36.00	Pass
11g	6Mbps	1	11	2462	23.70	30.00	-2.00	21.70	36.00	Pass
HT20	MCS0	1	1	2412	21.56	30.00	-2.00	19.56	36.00	Pass
HT20	MCS0	1	6	2437	21.66	30.00	-2.00	19.66	36.00	Pass
HT20	MCS0	1	11	2462	21.41	30.00	-2.00	19.41	36.00	Pass
HT40	MCS0	1	3	2422	22.31	30.00	-2.00	20.31	36.00	Pass
HT40	MCS0	1	6	2437	22.62	30.00	-2.00	20.62	36.00	Pass
HT40	MCS0	1	9	2452	22.43	30.00	-2.00	20.43	36.00	Pass

TEST RESULTS DATA
Average Power Table
(Reporting Only)

2.4GHz Band						
Mod.	Data Rate	N _{TX}	CH.	Freq. (MHz)	Duty Factor (dB)	Average Conducted Power (dBm)
11b	1Mbps	1	1	2412	0.00	17.73
11b	1Mbps	1	6	2437	0.00	17.81
11b	1Mbps	1	11	2462	0.00	17.65
11g	6Mbps	1	1	2412	0.12	14.63
11g	6Mbps	1	6	2437	0.12	14.78
11g	6Mbps	1	11	2462	0.12	14.68
HT20	MCS0	1	1	2412	0.13	11.29
HT20	MCS0	1	6	2437	0.13	11.36
HT20	MCS0	1	11	2462	0.13	11.19
HT40	MCS0	1	3	2422	0.24	11.19
HT40	MCS0	1	6	2437	0.24	11.36
HT40	MCS0	1	9	2452	0.24	11.25

TEST RESULTS DATA
Peak Power Density

2.4GHz Band								
Mod.	Data Rate	N _{TX}	CH.	Freq. (MHz)	Peak PSD (dBm /3kHz)	DG (dBi)	Peak PSD Limit (dBm /3kHz)	Pass/Fail
11b	1Mbps	1	1	2412	-6.68	-2.00	8.00	Pass
11b	1Mbps	1	6	2437	-5.44	-2.00	8.00	Pass
11b	1Mbps	1	11	2462	-5.68	-2.00	8.00	Pass
11g	6Mbps	1	1	2412	-10.10	-2.00	8.00	Pass
11g	6Mbps	1	6	2437	-10.80	-2.00	8.00	Pass
11g	6Mbps	1	11	2462	-10.25	-2.00	8.00	Pass
HT20	MCS0	1	1	2412	-13.54	-2.00	8.00	Pass
HT20	MCS0	1	6	2437	-13.92	-2.00	8.00	Pass
HT20	MCS0	1	11	2462	-15.33	-2.00	8.00	Pass
HT40	MCS0	1	3	2422	-18.77	-2.00	8.00	Pass
HT40	MCS0	1	6	2437	-18.07	-2.00	8.00	Pass
HT40	MCS0	1	9	2452	-16.17	-2.00	8.00	Pass



Appendix B. Radiated Spurious Emission

Test Engineer :	Ken Wu, James Chiu, and Jesse Wang	Temperature :	21~24°C
		Relative Humidity :	50~54%

**2.4GHz 2400~2483.5MHz
WIFI 802.11b (Band Edge @ 3m)**

WIFI Ant. 1	Note	Frequency (MHz)	Level (dBμV/m)	Over Limit (dB)	Limit Line (dBμV/m)	Read Level (dBμV)	Antenna Factor (dB/m)	Cable Loss (dB)	Preamp Factor (dB)	Ant Pos (cm)	Table Pos (deg)	Peak Avg. (P/A)	Pol. (H/V)	
802.11b CH 01 2412MHz		2323.23	56.13	-17.87	74	51.3	32.09	7.18	34.44	100	296	P	H	
		2389.92	45.15	-8.85	54	39.98	32.18	7.31	34.32	100	296	A	H	
	*	2410.6	105.92	-	-	100.73	32.2	7.31	34.32	100	296	P	H	
	*	2410.69	103.2	-	-	98.01	32.2	7.31	34.32	100	296	A	H	
													H	
														H
			2385.15	55.44	-18.56	74	50.33	32.16	7.31	34.36	352	67	P	V
			2389.83	44.79	-9.21	54	39.62	32.18	7.31	34.32	352	67	A	V
	*		2410.77	102.84	-	-	97.65	32.2	7.31	34.32	352	67	P	V
	*		2410.69	100.18	-	-	94.99	32.2	7.31	34.32	352	67	A	V
														V
														V
802.11b CH 06 2437MHz		2345.91	55.4	-18.6	74	50.45	32.11	7.24	34.4	103	319	P	H	
		2388.03	44.68	-9.32	54	39.55	32.18	7.31	34.36	103	319	A	H	
	*	2438.41	106.26	-	-	100.93	32.24	7.36	34.27	103	319	P	H	
	*	2438.33	103.61	-	-	98.28	32.24	7.36	34.27	103	319	A	H	
			2488.2	55.7	-18.3	74	50.19	32.3	7.4	34.19	103	319	P	H
			2485.6	45.2	-8.8	54	39.71	32.28	7.4	34.19	103	319	A	H
			2327.01	55.59	-18.41	74	50.76	32.09	7.18	34.44	358	136	P	V
			2389.92	44.62	-9.38	54	39.45	32.18	7.31	34.32	358	136	A	V
	*		2435.74	103.66	-	-	98.35	32.22	7.36	34.27	358	136	P	V
	*		2435.82	100.93	-	-	95.62	32.22	7.36	34.27	358	136	A	V
			2488.76	56.14	-17.86	74	50.63	32.3	7.4	34.19	358	136	P	V
			2485.36	45.11	-8.89	54	39.62	32.28	7.4	34.19	358	136	A	V



802.11b CH 11 2462MHz	*	2463.29	105.93	-	-	100.5	32.26	7.4	34.23	100	323	P	H
	*	2463.21	103.37	-	-	97.94	32.26	7.4	34.23	100	323	A	H
		2498.04	55.73	-18.27	74	50.18	32.3	7.4	34.15	100	323	P	H
		2486.88	45.29	-8.71	54	39.8	32.28	7.4	34.19	100	323	A	H
													H
													H
	*	2463.38	101.47	-	-	96.04	32.26	7.4	34.23	352	91	P	V
	*	2463.21	98.7	-	-	93.27	32.26	7.4	34.23	352	91	A	V
		2495.24	56.33	-17.67	74	50.78	32.3	7.4	34.15	352	91	P	V
		2486.72	45.08	-8.92	54	39.59	32.28	7.4	34.19	352	91	A	V
													V
													V
Remark	1. No other spurious found. 2. All results are PASS against Peak and Average limit line.												



**2.4GHz 2400~2483.5MHz
WIFI 802.11b (Harmonic @ 3m)**

WIFI Ant. 1	Note	Frequency (MHz)	Level (dBμV/m)	Over Limit (dB)	Limit Line (dBμV/m)	Read Level (dBμV)	Antenna Factor (dB/m)	Cable Loss (dB)	Preamp Factor (dB)	Ant Pos (cm)	Table Pos (deg)	Peak Avg. (P/A)	Pol. (H/V)
802.11b CH 01 2412MHz		4824	49.07	-24.93	74	62.77	34.26	11.68	59.64	100	0	P	H
													H
													H
													H
													V
													V
													V
802.11b CH 06 2437MHz		4874	49.63	-24.37	74	63.37	34.3	11.53	59.57	100	0	P	H
		7311	41.18	-32.82	74	50.24	35.6	13.81	58.47	100	0	P	H
													H
													H
													V
													V
													V
802.11b CH 11 2462MHz		4924	53.19	-20.81	74	66.98	34.34	11.37	59.5	103	294	P	H
		4924	50.74	-3.26	54	64.53	34.34	11.37	59.5	103	294	A	H
		7386	42.81	-31.19	74	51.84	35.6	13.95	58.58	100	0	P	H
													H
													V
													V
													V
Remark	1. No other spurious found. 2. All results are PASS against Peak and Average limit line.												



2.4GHz 2400~2483.5MHz
WIFI 802.11g (Band Edge @ 3m)

WIFI Ant. 1	Note	Frequency (MHz)	Level (dBμV/m)	Over Limit (dB)	Limit Line (dBμV/m)	Read Level (dBμV)	Antenna Factor (dB/m)	Cable Loss (dB)	Preamp Factor (dB)	Ant Pos (cm)	Table Pos (deg)	Peak Avg. (P/A)	Pol. (H/V)	
802.11g CH 01 2412MHz		2389.83	56.66	-17.34	74	51.49	32.18	7.31	34.32	122	320	P	H	
		2389.83	47.13	-6.87	54	41.96	32.18	7.31	34.32	122	320	A	H	
	*	2410.19	105.75	-	-	100.56	32.2	7.31	34.32	122	320	P	H	
	*	2410.86	98.17	-	-	92.98	32.2	7.31	34.32	122	320	A	H	
													H	
														H
			2364.09	55.78	-18.22	74	50.81	32.13	7.24	34.4	352	67	P	V
			2341.05	46.83	-7.17	54	41.88	32.11	7.24	34.4	352	67	A	V
	*		2410.1	102.5	-	-	97.31	32.2	7.31	34.32	352	67	P	V
	*		2410.94	94.81	-	-	89.62	32.2	7.31	34.32	352	67	A	V
														V
														V
802.11g CH 06 2437MHz		2389.38	55.48	-18.52	74	50.35	32.18	7.31	34.36	102	321	P	H	
		2389.47	45.64	-8.36	54	40.51	32.18	7.31	34.36	102	321	A	H	
	*	2437.91	107.88	-	-	102.55	32.24	7.36	34.27	102	321	P	H	
	*	2435.91	100.23	-	-	94.92	32.22	7.36	34.27	102	321	A	H	
			2489.68	55.93	-18.07	74	50.42	32.3	7.4	34.19	102	321	P	H
			2484.24	46.47	-7.53	54	40.98	32.28	7.4	34.19	102	321	A	H
			2351.58	56.19	-17.81	74	51.22	32.13	7.24	34.4	348	110	P	V
			2389.65	45.51	-8.49	54	40.38	32.18	7.31	34.36	348	110	A	V
	*		2435.74	103.2	-	-	97.89	32.22	7.36	34.27	348	110	P	V
	*		2438.16	95.96	-	-	90.63	32.24	7.36	34.27	348	110	A	V
			2499.64	55.99	-18.01	74	50.44	32.3	7.4	34.15	348	110	P	V
			2489.48	46.01	-7.99	54	40.5	32.3	7.4	34.19	348	110	A	V



802.11g CH 11 2462MHz	*	2463.13	106.7	-	-	101.27	32.26	7.4	34.23	100	321	P	H
	*	2463.04	99.11	-	-	93.68	32.26	7.4	34.23	100	321	A	H
		2484	58.35	-15.65	74	52.86	32.28	7.4	34.19	100	321	P	H
		2483.56	47.45	-6.55	54	41.96	32.28	7.4	34.19	100	321	A	H
													H
													H
	*	2463.96	103.3	-	-	97.87	32.26	7.4	34.23	342	67	P	V
	*	2463.29	95.71	-	-	90.28	32.26	7.4	34.23	342	67	A	V
		2483.8	56.5	-17.5	74	51.01	32.28	7.4	34.19	342	67	P	V
		2483.68	46.92	-7.08	54	41.43	32.28	7.4	34.19	342	67	A	V
													V
													V
Remark	1. No other spurious found. 2. All results are PASS against Peak and Average limit line.												



**2.4GHz 2400~2483.5MHz
WIFI 802.11g (Harmonic @ 3m)**

WIFI Ant. 1	Note	Frequency (MHz)	Level (dBμV/m)	Over Limit (dB)	Limit Line (dBμV/m)	Read Level (dBμV)	Antenna Factor (dB/m)	Cable Loss (dB)	Preamp Factor (dB)	Ant Pos (cm)	Table Pos (deg)	Peak Avg. (P/A)	Pol. (H/V)
802.11g CH 01 2412MHz		4824	43.7	-30.3	74	57.4	34.26	11.68	59.64	100	0	P	H
													H
													H
													H
													V
													V
													V
802.11g CH 06 2437MHz		4874	45.57	-28.43	74	59.31	34.3	11.53	59.57	100	0	P	H
		7311	40.34	-33.66	74	49.4	35.6	13.81	58.47	100	0	P	H
													H
													H
													V
													V
													V
802.11g CH 11 2462MHz		4924	44.96	-29.04	74	58.75	34.34	11.37	59.5	100	0	P	H
		7386	40.86	-33.14	74	49.89	35.6	13.95	58.58	100	0	P	H
													H
													H
													V
													V
													V
Remark	1. No other spurious found. 2. All results are PASS against Peak and Average limit line.												



2.4GHz 2400~2483.5MHz
WIFI 802.11n HT20 (Band Edge @ 3m)

WIFI Ant. 1	Note	Frequency (MHz)	Level (dBµV/m)	Over Limit (dB)	Limit Line (dBµV/m)	Read Level (dBµV)	Antenna Factor (dB/m)	Cable Loss (dB)	Preamp Factor (dB)	Ant Pos (cm)	Table Pos (deg)	Peak Avg. (P/A)	Pol. (H/V)	
802.11n HT20 CH 01 2412MHz		2367.78	55.19	-18.81	74	50.18	32.13	7.24	34.36	122	320	P	H	
		2389.92	45.82	-8.18	54	40.65	32.18	7.31	34.32	122	320	A	H	
	*	2412	102	-	-	96.81	32.2	7.31	34.32	122	320	P	H	
	*	2412	93.03	-	-	87.84	32.2	7.31	34.32	122	320	A	H	
													H	
														H
			2313.42	56.01	-17.99	74	51.2	32.07	7.18	34.44	360	68	P	V
			2388.84	45.89	-8.11	54	40.76	32.18	7.31	34.36	360	68	A	V
	*		2412	98.94	-	-	93.75	32.2	7.31	34.32	360	68	P	V
	*		2412	91.36	-	-	86.17	32.2	7.31	34.32	360	68	A	V
														V
														V
802.11n HT20 CH 06 2437MHz		2381.64	55.76	-18.24	74	50.65	32.16	7.31	34.36	102	322	P	H	
		2387.67	45.46	-8.54	54	40.33	32.18	7.31	34.36	102	322	A	H	
	*	2437	103.12	-	-	97.79	32.24	7.36	34.27	102	322	P	H	
	*	2437	94.47	-	-	89.14	32.24	7.36	34.27	102	322	A	H	
			2484.76	56.14	-17.86	74	50.65	32.28	7.4	34.19	102	322	P	H
			2484.8	46.17	-7.83	54	40.68	32.28	7.4	34.19	102	322	A	H
			2323.14	55.61	-18.39	74	50.78	32.09	7.18	34.44	357	134	P	V
			2365.71	45.51	-8.49	54	40.5	32.13	7.24	34.36	357	134	A	V
	*		2437	99.07	-	-	93.74	32.24	7.36	34.27	357	134	P	V
	*		2437	91.8	-	-	86.47	32.24	7.36	34.27	357	134	A	V
			2491.88	55.99	-18.01	74	50.44	32.3	7.4	34.15	357	134	P	V
			2487.6	45.92	-8.08	54	40.41	32.3	7.4	34.19	357	134	A	V



802.11n HT20 CH 11 2462MHz	*	2463.71	101.72	-	-	96.29	32.26	7.4	34.23	100	321	P	H
	*	2463.38	94.33	-	-	88.9	32.26	7.4	34.23	100	321	A	H
		2498.36	56.74	-17.26	74	51.19	32.3	7.4	34.15	100	321	P	H
		2483.96	46.33	-7.67	54	40.84	32.28	7.4	34.19	100	321	A	H
													H
													H
	*	2462	98.42	-	-	92.99	32.26	7.4	34.23	341	66	P	V
	*	2462	90.78	-	-	85.35	32.26	7.4	34.23	341	66	A	V
		2498.6	55.95	-18.05	74	50.4	32.3	7.4	34.15	341	66	P	V
		2483.64	46.21	-7.79	54	40.72	32.28	7.4	34.19	341	66	A	V
												V	
												V	
Remark	1. No other spurious found. 2. All results are PASS against Peak and Average limit line.												



**2.4GHz 2400~2483.5MHz
WIFI 802.11n HT20 (Harmonic @ 3m)**

WIFI Ant. 1	Note	Frequency (MHz)	Level (dBμV/m)	Over Limit (dB)	Limit Line (dBμV/m)	Read Level (dBμV)	Antenna Factor (dB/m)	Cable Loss (dB)	Preamp Factor (dB)	Ant Pos (cm)	Table Pos (deg)	Peak Avg. (P/A)	Pol. (H/V)	
802.11n HT20 CH 01 2412MHz		4924	39.77	-34.23	74	53.56	34.34	11.37	59.5	100	0	P	H	
													H	
													H	
													H	
			4924	39.72	-34.28	74	53.51	34.34	11.37	59.5	100	0	P	V
														V
														V
802.11n HT20 CH 06 2437MHz		4874	41.79	-32.21	74	55.53	34.3	11.53	59.57	100	0	P	H	
		7311	39.83	-34.17	74	48.89	35.6	13.81	58.47	100	0	P	H	
													H	
													H	
			4874	39.76	-34.24	74	53.5	34.3	11.53	59.57	100	0	P	V
			7311	39.4	-34.6	74	48.46	35.6	13.81	58.47	100	0	P	V
														V
802.11n HT20 CH 11 2462MHz		4924	40.1	-33.9	74	53.89	34.34	11.37	59.5	100	0	P	H	
		7386	40.62	-33.38	74	49.65	35.6	13.95	58.58	100	0	P	H	
													H	
													H	
			4924	39.96	-34.04	74	53.75	34.34	11.37	59.5	100	0	P	V
			7386	40.62	-33.38	74	49.65	35.6	13.95	58.58	100	0	P	V
														V
Remark	1. No other spurious found.													
	2. All results are PASS against Peak and Average limit line.													



2.4GHz 2400~2483.5MHz
WIFI 802.11n HT40 (Band Edge @ 3m)

WIFI Ant. 1	Note	Frequency (MHz)	Level (dBµV/m)	Over Limit (dB)	Limit Line (dBµV/m)	Read Level (dBµV)	Antenna Factor (dB/m)	Cable Loss (dB)	Preamp Factor (dB)	Ant Pos (cm)	Table Pos (deg)	Peak Avg. (P/A)	Pol. (H/V)
802.11n HT40 CH 03 2422MHz		2388.93	58.82	-15.18	74	53.69	32.18	7.31	34.36	106	321	P	H
		2389.38	47.12	-6.88	54	41.99	32.18	7.31	34.36	106	321	A	H
	*	2422	99.79	-	-	94.48	32.22	7.36	34.27	106	321	P	H
	*	2422	91.66	-	-	86.35	32.22	7.36	34.27	106	321	A	H
		2495.56	56.29	-17.71	74	50.74	32.3	7.4	34.15	106	321	P	H
		2487.64	46.99	-7.01	54	41.48	32.3	7.4	34.19	106	321	A	H
		2389.56	57.24	-16.76	74	52.11	32.18	7.31	34.36	356	134	P	V
		2389.38	46.6	-7.4	54	41.47	32.18	7.31	34.36	356	134	A	V
	*	2422	96.8	-	-	91.49	32.22	7.36	34.27	356	134	P	V
	*	2422	88.89	-	-	83.58	32.22	7.36	34.27	356	134	A	V
		2488.52	56.26	-17.74	74	50.75	32.3	7.4	34.19	356	134	P	V
		2484.36	46.7	-7.3	54	41.21	32.28	7.4	34.19	356	134	A	V
802.11n HT40 CH 06 2437MHz		2345.64	55.63	-18.37	74	50.68	32.11	7.24	34.4	102	322	P	H
		2371.83	46.37	-7.63	54	41.33	32.16	7.24	34.36	102	322	A	H
	*	2437	100.08	-	-	94.75	32.24	7.36	34.27	102	322	P	H
	*	2437	92.55	-	-	87.22	32.24	7.36	34.27	102	322	A	H
		2497.16	56.18	-17.82	74	50.63	32.3	7.4	34.15	102	322	P	H
		2484.92	47.34	-6.66	54	41.85	32.28	7.4	34.19	102	322	A	H
		2372.19	55.31	-18.69	74	50.27	32.16	7.24	34.36	356	134	P	V
		2379.57	46.34	-7.66	54	41.3	32.16	7.24	34.36	356	134	A	V
	*	2437	97.27	-	-	91.94	32.24	7.36	34.27	356	134	P	V
	*	2437	89.82	-	-	84.49	32.24	7.36	34.27	356	134	A	V
		2496.8	55.98	-18.02	74	50.43	32.3	7.4	34.15	356	134	P	V
		2496.6	46.96	-7.04	54	41.41	32.3	7.4	34.15	356	134	A	V



802.11n HT40 CH 09 2452MHz		2366.52	55.4	-18.6	74	50.39	32.13	7.24	34.36	100	322	P	H
		2387.58	46.28	-7.72	54	41.15	32.18	7.31	34.36	100	322	A	H
	*	2452	99.77	-	-	94.4	32.24	7.36	34.23	100	322	P	H
	*	2452	92.12	-	-	86.75	32.24	7.36	34.23	100	322	A	H
		2483.52	59.96	-14.04	74	54.47	32.28	7.4	34.19	100	322	P	H
		2483.6	47.66	-6.34	54	42.17	32.28	7.4	34.19	100	322	A	H
		2365.17	55.81	-18.19	74	50.8	32.13	7.24	34.36	356	138	P	V
		2346.81	46.19	-7.81	54	41.24	32.11	7.24	34.4	356	138	A	V
	*	2452	95.38	-	-	90.01	32.24	7.36	34.23	356	138	P	V
	*	2452	88.33	-	-	82.96	32.24	7.36	34.23	356	138	A	V
		2483.6	58.28	-15.72	74	52.79	32.28	7.4	34.19	356	138	P	V
		2487.36	47.17	-6.83	54	41.68	32.28	7.4	34.19	356	138	A	V
Remark	1. No other spurious found. 2. All results are PASS against Peak and Average limit line.												



**2.4GHz 2400~2483.5MHz
WIFI 802.11n HT40 (Harmonic @ 3m)**

WIFI Ant. 1	Note	Frequency (MHz)	Level (dBμV/m)	Over Limit (dB)	Limit Line (dBμV/m)	Read Level (dBμV)	Antenna Factor (dB/m)	Cable Loss (dB)	Preamp Factor (dB)	Ant Pos (cm)	Table Pos (deg)	Peak Avg. (P/A)	Pol. (H/V)
802.11n HT40 CH 03 2422MHz		4844	41.38	-32.62	74	55.04	34.28	11.68	59.62	100	0	P	H
		7266	41.27	-32.73	74	50.35	35.6	13.75	58.43	100	0	P	H
													H
													H
		4844	40.56	-33.44	74	54.22	34.28	11.68	59.62	100	0	P	V
		7266	40.4	-33.6	74	49.48	35.6	13.75	58.43	100	0	P	V
802.11n HT40 CH 06 2437MHz		4874	40.6	-33.4	74	54.34	34.3	11.53	59.57	100	0	P	H
		7311	40.15	-33.85	74	49.21	35.6	13.81	58.47	100	0	P	H
													H
													H
		4874	40.69	-33.31	74	54.43	34.3	11.53	59.57	100	0	P	V
		7311	40.97	-33.03	74	50.03	35.6	13.81	58.47	100	0	P	V
802.11n HT40 CH 09 2452MHz		4904	40.86	-33.14	74	54.68	34.33	11.37	59.52	100	0	P	H
		7356	40.52	-33.48	74	49.57	35.6	13.88	58.53	100	0	P	H
													H
													H
		4904	40.53	-33.47	74	54.35	34.33	11.37	59.52	100	0	P	V
		7356	40.37	-33.63	74	49.42	35.6	13.88	58.53	100	0	P	V
Remark	1. No other spurious found.												
	2. All results are PASS against Peak and Average limit line.												



**2.4GHz 2400~2483.5MHz
Emission below 1GHz
2.4GHz WIFI 802.11b (LF)**

WIFI Ant. 1	Note	Frequency (MHz)	Level (dBμV/m)	Over Limit (dB)	Limit Line (dBμV/m)	Read Level (dBμV)	Antenna Factor (dB/m)	Cable Loss (dB)	Preamp Factor (dB)	Ant Pos (cm)	Table Pos (deg)	Peak Avg. (P/A)	Pol. (H/V)	
2.4GHz 802.11b LF		30	27.82	-12.18	40	32.25	26	1.07	31.5	-	-	P	H	
		161.49	25.07	-18.43	43.5	37.67	16.8	1.78	31.18	-	-	P	H	
		277.86	24.9	-21.1	46	34.19	19.32	2.32	30.93	-	-	P	H	
		878.2	32.79	-13.21	46	30.09	28.87	4.17	30.34	-	-	P	H	
		935.6	33.06	-12.94	46	29.44	29.87	4.12	30.37	-	-	P	H	
		949.6	33.87	-12.13	46	30	30.2	4.07	30.4	100	0	P	H	
													H	
													H	
													H	
													H	
													H	
													H	
													H	
													H	
			30	30.95	-9.05	40	35.38	26	1.07	31.5	100	0	P	V
			160.14	21.71	-21.79	43.5	34.12	17	1.78	31.19	-	-	P	V
			291.36	22.45	-23.55	46	31.51	19.71	2.32	31.09	-	-	P	V
			881.7	32.77	-13.23	46	30.05	28.89	4.17	30.34	-	-	P	V
			920.9	33.37	-12.63	46	30.1	29.49	4.12	30.34	-	-	P	V
			947.5	32.87	-13.13	46	29.04	30.15	4.07	30.39	-	-	P	V
												V		
												V		
												V		
												V		
												V		
												V		
Remark	1. No other spurious found. 2. All results are PASS against limit line.													



Emission below 1GHz
2.4GHz WIFI 802.11g (LF)

WIFI Ant. 1	Note	Frequency (MHz)	Level (dBμV/m)	Over Limit (dB)	Limit Line (dBμV/m)	Read Level (dBμV)	Antenna Factor (dB/m)	Cable Loss (dB)	Preamp Factor (dB)	Ant Pos (cm)	Table Pos (deg)	Peak Avg. (P/A)	Pol. (H/V)
		31.35	25.96	-14.04	40	30.85	25.46	1.07	31.42	100	0	P	H
		89.4	24.89	-18.61	43.5	39.73	14.98	1.28	31.1	-	-	P	H
		283.26	22.64	-23.36	46	31.86	19.42	2.32	30.96	-	-	P	H
		746.6	31.64	-14.36	46	31.07	27.15	3.82	30.4	-	-	P	H
		838.3	30.86	-15.14	46	28.68	28.46	4.1	30.38	-	-	P	H
		932.8	31.87	-14.13	46	28.32	29.8	4.12	30.37	-	-	P	H
													H
													H
													H
													H
													H
													H
2.4GHz 802.11g LF		30	28.52	-11.48	40	32.95	26	1.07	31.5	100	0	P	V
		193.62	23.69	-19.81	43.5	37.22	15.7	1.87	31.1	-	-	P	V
		257.61	27.27	-18.73	46	36.4	19.8	2.07	31	-	-	P	V
		899.2	31.53	-14.47	46	28.67	28.99	4.17	30.3	-	-	P	V
		908.3	32.01	-13.99	46	29.02	29.19	4.12	30.32	-	-	P	V
		951	32.36	-13.64	46	28.49	30.2	4.07	30.4	-	-	P	V
													V
													V
													V
													V
													V
													V
													V
Remark	1. No other spurious found. 2. All results are PASS against limit line.												



Emission below 1GHz
2.4GHz WIFI 802.11n HT20 (LF)

WIFI Ant. 1	Note	Frequency (MHz)	Level (dBμV/m)	Over Limit (dB)	Limit Line (dBμV/m)	Read Level (dBμV)	Antenna Factor (dB/m)	Cable Loss (dB)	Preamp Factor (dB)	Ant Pos (cm)	Table Pos (deg)	Peak Avg. (P/A)	Pol. (H/V)	
2.4GHz 802.11n HT20 LF		30	27.8	-12.2	40	32.23	26	1.07	31.5	-	-	P	H	
		159.87	25.16	-18.34	43.5	37.58	17	1.78	31.2	-	-	P	H	
		283.8	24.1	-21.9	46	33.28	19.46	2.32	30.96	-	-	P	H	
		845.3	32.24	-13.76	46	29.91	28.62	4.1	30.39	-	-	P	H	
		909	32.98	-13.02	46	29.97	29.21	4.12	30.32	-	-	P	H	
		941.9	34.26	-11.74	46	30.56	30.01	4.07	30.38	100	0	P	H	
														H
														H
														H
														H
														H
														H
			30.27	29.05	-10.95	40	33.48	26	1.07	31.5	100	0	P	V
			166.89	22.81	-20.69	43.5	35.86	16.3	1.78	31.13	-	-	P	V
			288.12	23.24	-22.76	46	32.36	19.62	2.32	31.06	-	-	P	V
			812.4	31.66	-14.34	46	30.14	27.95	3.9	30.33	-	-	P	V
			855.8	33.17	-12.83	46	30.73	28.73	4.1	30.39	-	-	P	V
			930	33.8	-12.2	46	30.31	29.73	4.12	30.36	-	-	P	V
														V
														V
													V	
													V	
													V	
													V	
Remark	1. No other spurious found. 2. All results are PASS against limit line.													



Emission below 1GHz
2.4GHz WIFI 802.11n HT40 (LF)

WIFI Ant. 1	Note	Frequency (MHz)	Level (dBµV/m)	Over Limit (dB)	Limit Line (dBµV/m)	Read Level (dBµV)	Antenna Factor (dB/m)	Cable Loss (dB)	Preamp Factor (dB)	Ant Pos (cm)	Table Pos (deg)	Peak Avg. (P/A)	Pol. (H/V)
		30	28.99	-11.01	40	33.42	26	1.07	31.5	100	0	P	H
		159.33	27.46	-16.04	43.5	39.81	17.07	1.78	31.2	-	-	P	H
		280.83	25.63	-20.37	46	34.87	19.34	2.32	30.9	-	-	P	H
		736.8	30.71	-15.29	46	30.37	27	3.74	30.4	-	-	P	H
		807.5	32.63	-13.37	46	31.19	27.86	3.9	30.32	-	-	P	H
		955.2	33.54	-12.46	46	29.64	30.21	4.07	30.38	-	-	P	H
													H
													H
													H
													H
													H
													H
2.4GHz													H
802.11n													H
HT40		30	30	-10	40	34.43	26	1.07	31.5	100	0	P	V
LF		197.94	22.67	-20.83	43.5	36	15.9	1.87	31.1	-	-	P	V
		267.06	21.63	-24.37	46	30.73	19.58	2.32	31	-	-	P	V
		798.4	31.32	-14.68	46	30.04	27.68	3.9	30.3	-	-	P	V
		841.1	32.96	-13.04	46	30.72	28.52	4.1	30.38	-	-	P	V
		951.7	33.88	-12.12	46	30.01	30.2	4.07	30.4	-	-	P	V
													V
													V
													V
													V
													V
													V
													V
													V
													V
Remark	1. No other spurious found. 2. All results are PASS against limit line.												



Note symbol

*	Fundamental Frequency which can be ignored. However, the level of any unwanted emissions shall not exceed the level of the fundamental frequency.
!	Test result is over limit line.
P/A	Peak or Average
H/V	Horizontal or Vertical



A calculation example for radiated spurious emission is shown as below:

WIFI Ant. 1	Note	Frequency (MHz)	Level (dBμV/m)	Over Limit (dB)	Limit Line (dBμV/m)	Read Level (dBμV)	Antenna Factor (dB/m)	Cable Loss (dB)	Preamp Factor (dB)	Ant Pos (cm)	Table Pos (deg)	Peak Avg. (P/A)	Pol. (H/V)
802.11b CH 01		2390	55.45	-18.55	74	54.51	32.22	4.58	35.86	103	308	P	H
2412MHz		2390	43.54	-10.46	54	42.6	32.22	4.58	35.86	103	308	A	H

- Level(dBμV/m) =
Antenna Factor(dB/m) + Cable Loss(dB) + Read Level(dBμV) - Preamp Factor(dB)
- Over Limit(dB) = Level(dBμV/m) – Limit Line(dBμV/m)

For Peak Limit @ 2390MHz:

- Level(dBμV/m)
= Antenna Factor(dB/m) + Cable Loss(dB) + Read Level(dBμV) - Preamp Factor(dB)
= 32.22(dB/m) + 4.58(dB) + 54.51(dBμV) – 35.86 (dB)
= 55.45 (dBμV/m)
- Over Limit(dB)
= Level(dBμV/m) – Limit Line(dBμV/m)
= 55.45(dBμV/m) – 74(dBμV/m)
= -18.55(dB)

For Average Limit @ 2390MHz:

- Level(dBμV/m)
= Antenna Factor(dB/m) + Cable Loss(dB) + Read Level(dBμV) - Preamp Factor(dB)
= 32.22(dB/m) + 4.58(dB) + 42.6(dBμV) – 35.86 (dB)
= 43.54 (dBμV/m)
- Over Limit(dB)
= Level(dBμV/m) – Limit Line(dBμV/m)
= 43.54(dBμV/m) – 54(dBμV/m)
= -10.46(dB)

Both peak and average measured complies with the limit line, so test result is “PASS”.



Appendix C. Radiated Spurious Emission Plots

Test Engineer :	Ken Wu, James Chiu, and Jesse Wang	Temperature :	21~24°C
		Relative Humidity :	50~54%

Note symbol

-L	Low channel location
-R	High channel location



2.4GHz 2400~2483.5MHz
WIFI 802.11b (Band Edge @ 3m)

Table with 4 columns: WIFI, ANT, 1, and two sub-columns for Horizontal and Vertical. Rows are labeled Peak and Avg. Each cell contains a graph of Level (dBuV/m) vs Frequency (MHz) with FCC CLASS-B limits and test parameters.

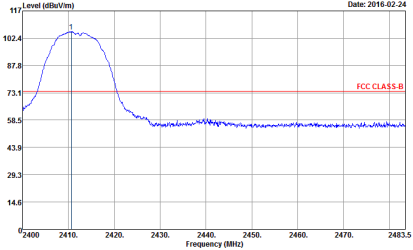
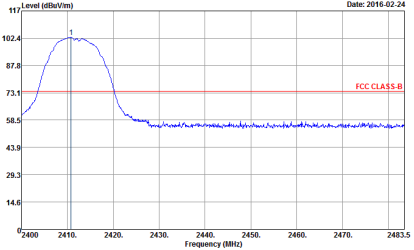
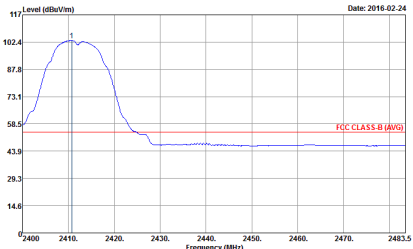
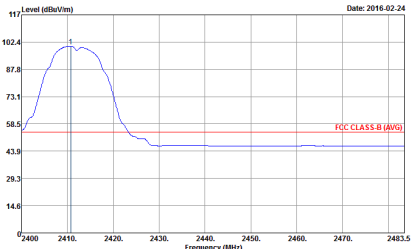

WIFI	2.4GHz 2400~2483.5MHz Fundamental @ 3m	
ANT	802.11b CH01 2412MHz	
1	Horizontal	Vertical
Peak	 <p>Date: 2016-02-24</p> <p>Site : 03CH07-HY Condition : FCC CLASS-B 3m HF-ANT_130829 HORIZONTAL RBW:1000.000kHz VBW:3000.000kHz SWT:Auto Detector : Peak Project : 620405 Mode : 15</p>	 <p>Date: 2016-02-24</p> <p>Site : 03CH07-HY Condition : FCC CLASS-B 3m HF-ANT_130829 VERTICAL RBW:1000.000kHz VBW:3000.000kHz SWT:Auto Detector : Peak Project : 620405 Mode : 15</p>
Avg.	 <p>Date: 2016-02-24</p> <p>Site : 03CH07-HY Condition : FCC CLASS-B (AVG) 3m HF-ANT_130829 HORIZONTAL RBW:1000.000kHz VBW:0.010kHz SWT:Auto Detector : Peak Project : 620405 Mode : 15</p>	 <p>Date: 2016-02-24</p> <p>Site : 03CH07-HY Condition : FCC CLASS-B (AVG) 3m HF-ANT_130829 VERTICAL RBW:1000.000kHz VBW:0.010kHz SWT:Auto Detector : Peak Project : 620405 Mode : 15</p>

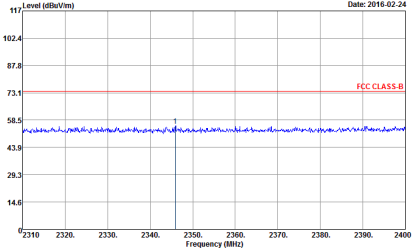
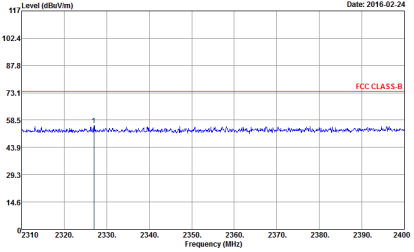
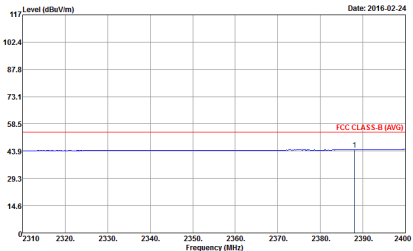
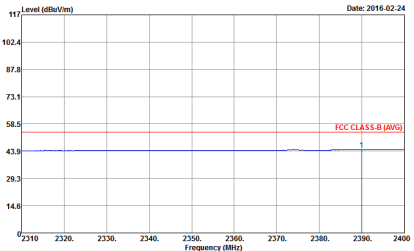

WIFI	2.4GHz 2400~2483.5MHz Band Edge @ 3m	
ANT	802.11b CH06 2437MHz - L	
1	Horizontal	Vertical
Peak	 <p>Date: 2016-02-24</p> <p>Site : 03CH07-HY Condition : FCC CLASS-B 3m HF-ANT_138829 HORIZONTAL RBW:1000.000kHz VBW:3000.000kHz SWT:Auto Detector : Peak Project : 620405 Mode : 16</p>	 <p>Date: 2016-02-24</p> <p>Site : 03CH07-HY Condition : FCC CLASS-B 3m HF-ANT_138829 VERTICAL RBW:1000.000kHz VBW:3000.000kHz SWT:Auto Detector : Peak Project : 620405 Mode : 16</p>
Avg.	 <p>Date: 2016-02-24</p> <p>Site : 03CH07-HY Condition : FCC CLASS-B (AVG) 3m HF-ANT_138829 HORIZONTAL RBW:1000.000kHz VBW:0.010kHz SWT:Auto Detector : Peak Project : 620405 Mode : 16</p>	 <p>Date: 2016-02-24</p> <p>Site : 03CH07-HY Condition : FCC CLASS-B (AVG) 3m HF-ANT_138829 VERTICAL RBW:1000.000kHz VBW:0.010kHz SWT:Auto Detector : Peak Project : 620405 Mode : 16</p>

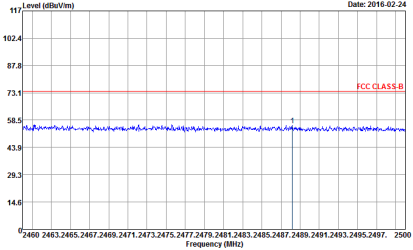
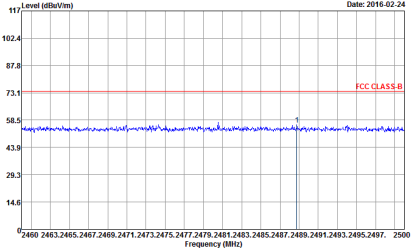
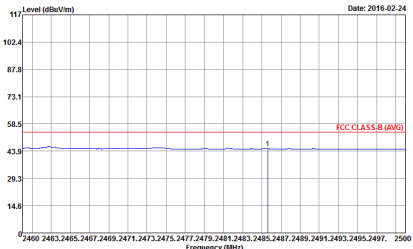
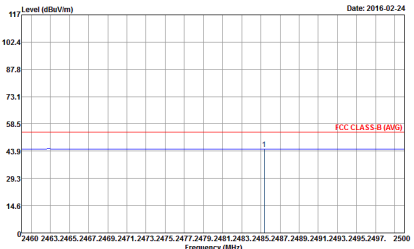

WIFI	2.4GHz 2400~2483.5MHz Band Edge @ 3m	
ANT	802.11b CH06 2437MHz - R	
1	Horizontal	Vertical
Peak	 <p>Date: 2016-02-24</p> <p>Site : 03CH07-HY Condition : FCC CLASS-B 3m HF-ANT_130829 HORIZONTAL RBW:1000.000kHz VBW:3000.000kHz SWT:Auto Detector : Peak Project : 620405 Mode : 16</p>	 <p>Date: 2016-02-24</p> <p>Site : 03CH07-HY Condition : FCC CLASS-B 3m HF-ANT_130829 VERTICAL RBW:1000.000kHz VBW:3000.000kHz SWT:Auto Detector : Peak Project : 620405 Mode : 16</p>
Avg.	 <p>Date: 2016-02-24</p> <p>Site : 03CH07-HY Condition : FCC CLASS-B (AVG) 3m HF-ANT_130829 HORIZONTAL RBW:1000.000kHz VBW:0.010kHz SWT:Auto Detector : Peak Project : 620405 Mode : 16</p>	 <p>Date: 2016-02-24</p> <p>Site : 03CH07-HY Condition : FCC CLASS-B (AVG) 3m HF-ANT_130829 VERTICAL RBW:1000.000kHz VBW:0.010kHz SWT:Auto Detector : Peak Project : 620405 Mode : 16</p>

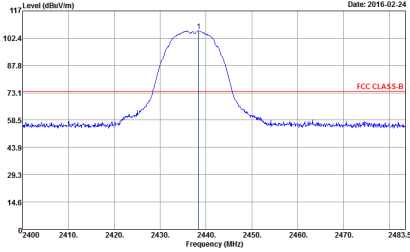
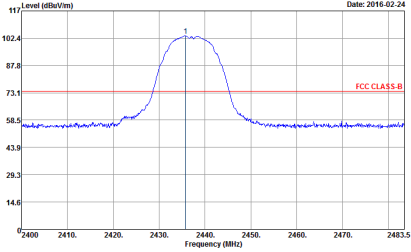
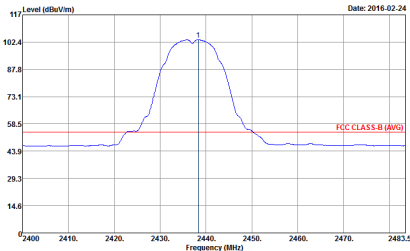
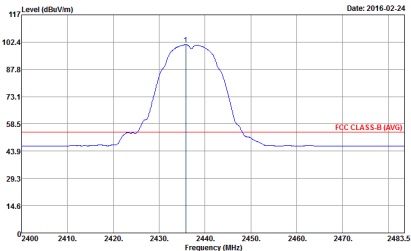

WIFI	2.4GHz 2400~2483.5MHz Fundamental @ 3m	
ANT	802.11b CH06 2437MHz	
1	Horizontal	Vertical
Peak	 <p>Date: 2016-02-24</p> <p>Site : 03CH07-HY Condition : FCC CLASS-B 3m HF-ANT_13829 HORIZONTAL RBW:1000.000kHz VBW:3000.000kHz SWT:Auto Detector : Peak Project : 620405 Mode : 16</p>	 <p>Date: 2016-02-24</p> <p>Site : 03CH07-HY Condition : FCC CLASS-B 3m HF-ANT_13829 VERTICAL RBW:1000.000kHz VBW:3000.000kHz SWT:Auto Detector : Peak Project : 620405 Mode : 16</p>
Avg.	 <p>Date: 2016-02-24</p> <p>Site : 03CH07-HY Condition : FCC CLASS-B (AVG) 3m HF-ANT_13829 HORIZONTAL RBW:1000.000kHz VBW:0.010kHz SWT:Auto Detector : Peak Project : 620405 Mode : 16</p>	 <p>Date: 2016-02-24</p> <p>Site : 03CH07-HY Condition : FCC CLASS-B (AVG) 3m HF-ANT_13829 VERTICAL RBW:1000.000kHz VBW:0.010kHz SWT:Auto Detector : Peak Project : 620405 Mode : 16</p>

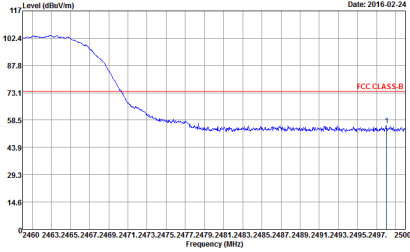
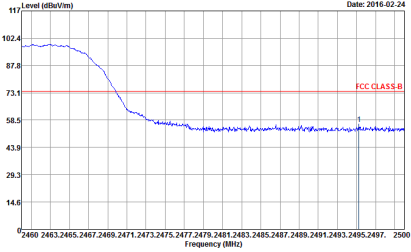
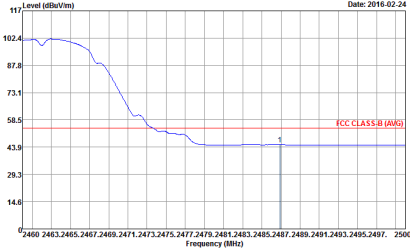
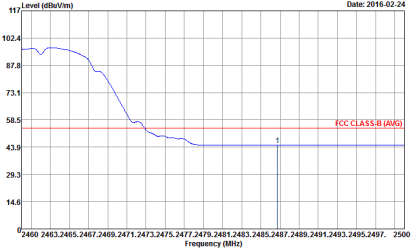

WIFI	2.4GHz 2400~2483.5MHz Band Edge @ 3m	
ANT	802.11b CH11 2462MHz	
1	Horizontal	Vertical
Peak	 <p>Date: 2016-02-24</p> <p>Site : 03CH07-HY Condition : FCC CLASS-B 3m HF-ANT_130829 HORIZONTAL RBW:1000.000kHz VBW:3000.000kHz SWT:Auto Detector : Peak Project : 620405 Mode : 17</p>	 <p>Date: 2016-02-24</p> <p>Site : 03CH07-HY Condition : FCC CLASS-B 3m HF-ANT_130829 VERTICAL RBW:1000.000kHz VBW:3000.000kHz SWT:Auto Detector : Peak Project : 620405 Mode : 17</p>
Avg.	 <p>Date: 2016-02-24</p> <p>Site : 03CH07-HY Condition : FCC CLASS-B (AVG) 3m HF-ANT_130829 HORIZONTAL RBW:1000.000kHz VBW:0.010kHz SWT:Auto Detector : Peak Project : 620405 Mode : 17</p>	 <p>Date: 2016-02-24</p> <p>Site : 03CH07-HY Condition : FCC CLASS-B (AVG) 3m HF-ANT_130829 VERTICAL RBW:1000.000kHz VBW:0.010kHz SWT:Auto Detector : Peak Project : 620405 Mode : 17</p>

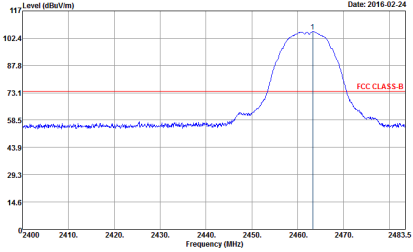
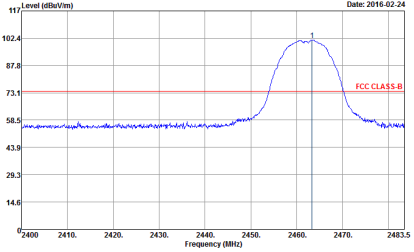
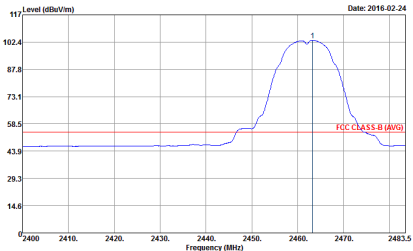
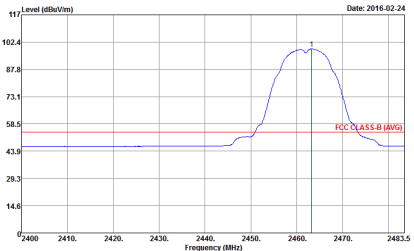

WIFI	2.4GHz 2400~2483.5MHz Fundamental @ 3m	
ANT	802.11b CH11 2462MHz	
1	Horizontal	Vertical
Peak	 <p>Site : 03CH07-HY Condition : FCC CLASS-B 3m HF-ANT_13829 HORIZONTAL RBW:1000.000kHz VBW:3000.000kHz SWT:Auto Detector : Peak Project : 620405 Mode : 17</p>	 <p>Site : 03CH07-HY Condition : FCC CLASS-B 3m HF-ANT_13829 VERTICAL RBW:1000.000kHz VBW:3000.000kHz SWT:Auto Detector : Peak Project : 620405 Mode : 17</p>
Avg.	 <p>Site : 03CH07-HY Condition : FCC CLASS-B (AVG) 3m HF-ANT_13829 HORIZONTAL RBW:1000.000kHz VBW:0.010kHz SWT:Auto Detector : Peak Project : 620405 Mode : 17</p>	 <p>Site : 03CH07-HY Condition : FCC CLASS-B (AVG) 3m HF-ANT_13829 VERTICAL RBW:1000.000kHz VBW:0.010kHz SWT:Auto Detector : Peak Project : 620405 Mode : 17</p>

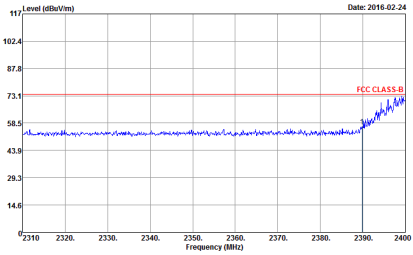
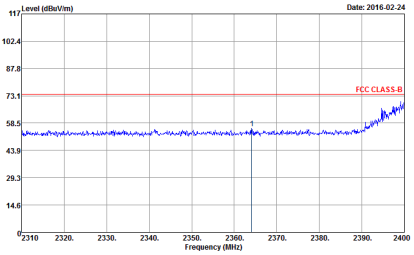
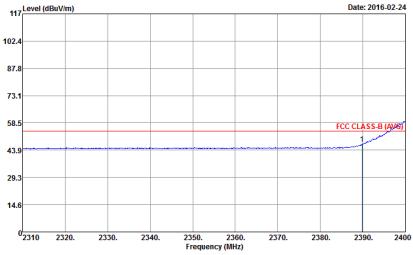
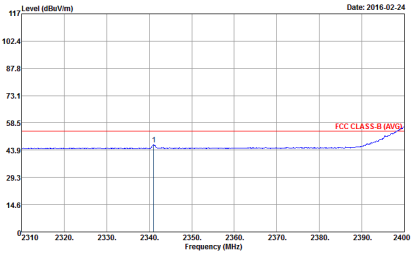

2.4GHz 2400~2483.5MHz
WIFI 802.11g (Band Edge @ 3m)

WIFI	2.4GHz 2400~2483.5MHz Band Edge @ 3m	
ANT	802.11g CH01 2412MHz	
1	Horizontal	Vertical
Peak	 <p>Site : 03CH07.HY Condition : FCC CLASS-B 3m HF-ANT_130829 HORIZONTAL RBW:1000.000kHz VBW:3000.000kHz SWT:Auto Detector : Peak Project : 620405 Mode : 18</p>	 <p>Site : 03CH07.HY Condition : FCC CLASS-B 3m HF-ANT_130829 VERTICAL RBW:1000.000kHz VBW:3000.000kHz SWT:Auto Detector : Peak Project : 620405 Mode : 18</p>
Avg.	 <p>Site : 03CH07.HY Condition : FCC CLASS-B (AVG) 3m HF-ANT_130829 HORIZONTAL RBW:1000.000kHz VBW:1.000kHz SWT:Auto Detector : Peak Project : 620405 Mode : 18</p>	 <p>Site : 03CH07.HY Condition : FCC CLASS-B (AVG) 3m HF-ANT_130829 VERTICAL RBW:1000.000kHz VBW:1.000kHz SWT:Auto Detector : Peak Project : 620405 Mode : 18</p>

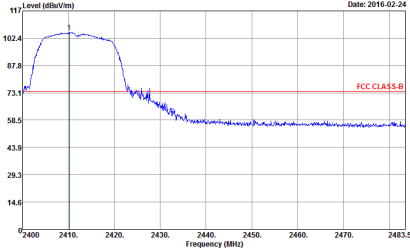
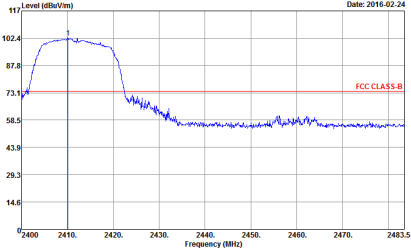
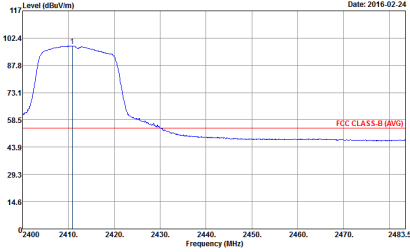
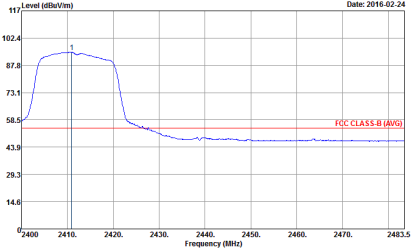

WIFI	2.4GHz 2400~2483.5MHz Fundamental @ 3m	
ANT	802.11g CH01 2412MHz	
1	Horizontal	Vertical
Peak	 <p>Date: 2016-02-24</p> <p>Site : 03CH07-HY Condition : FCC CLASS-B 3m HF-ANT_130829 HORIZONTAL RBW:1000.000kHz VBW:3000.000kHz SWT:Auto Detector : Peak Project : 620405 Mode : 18</p>	 <p>Date: 2016-02-24</p> <p>Site : 03CH07-HY Condition : FCC CLASS-B 3m HF-ANT_130829 VERTICAL RBW:1000.000kHz VBW:3000.000kHz SWT:Auto Detector : Peak Project : 620405 Mode : 18</p>
Avg.	 <p>Date: 2016-02-24</p> <p>Site : 03CH07-HY Condition : FCC CLASS-B (AVG) 3m HF-ANT_130829 HORIZONTAL RBW:1000.000kHz VBW:1.000kHz SWT:Auto Detector : Peak Project : 620405 Mode : 18</p>	 <p>Date: 2016-02-24</p> <p>Site : 03CH07-HY Condition : FCC CLASS-B (AVG) 3m HF-ANT_130829 VERTICAL RBW:1000.000kHz VBW:1.000kHz SWT:Auto Detector : Peak Project : 620405 Mode : 18</p>

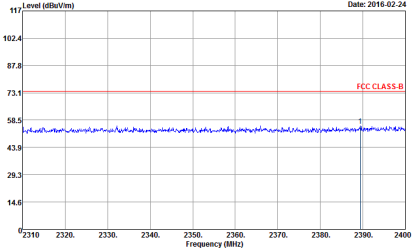
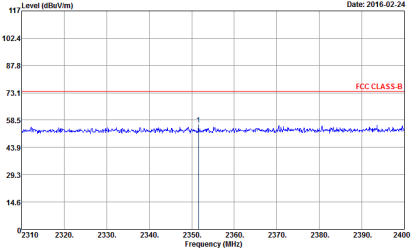
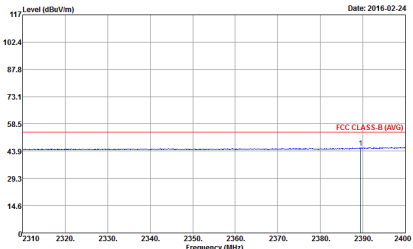
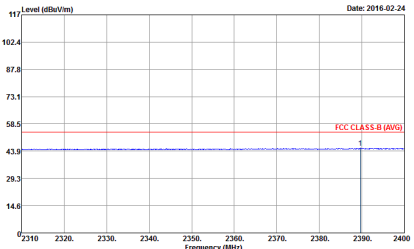

WIFI	2.4GHz 2400~2483.5MHz Band Edge @ 3m	
ANT	802.11g CH06 2437MHz - L	
1	Horizontal	Vertical
Peak	 <p>Date: 2016-02-24</p> <p>Level (dBuV/m): 117, 102.4, 87.8, 73.1, 58.5, 43.9, 29.3, 14.6</p> <p>Frequency (MHz): 2310, 2320, 2330, 2340, 2350, 2360, 2370, 2380, 2390, 2400</p> <p>Site : 03CH07-HY Condition : FCC CLASS-B 3m HF-ANT_130829 HORIZONTAL RBW:1000.000kHz VBW:3000.000kHz SWT:Auto Detector : Peak Project : 620405 Mode : 19</p>	 <p>Date: 2016-02-24</p> <p>Level (dBuV/m): 117, 102.4, 87.8, 73.1, 58.5, 43.9, 29.3, 14.6</p> <p>Frequency (MHz): 2310, 2320, 2330, 2340, 2350, 2360, 2370, 2380, 2390, 2400</p> <p>Site : 03CH07-HY Condition : FCC CLASS-B 3m HF-ANT_130829 VERTICAL RBW:1000.000kHz VBW:3000.000kHz SWT:Auto Detector : Peak Project : 620405 Mode : 19</p>
Avg.	 <p>Date: 2016-02-24</p> <p>Level (dBuV/m): 117, 102.4, 87.8, 73.1, 58.5, 43.9, 29.3, 14.6</p> <p>Frequency (MHz): 2310, 2320, 2330, 2340, 2350, 2360, 2370, 2380, 2390, 2400</p> <p>Site : 03CH07-HY Condition : FCC CLASS-B (AVG) 3m HF-ANT_130829 HORIZONTAL RBW:1000.000kHz VBW:1.000kHz SWT:Auto Detector : Peak Project : 620405 Mode : 19</p>	 <p>Date: 2016-02-24</p> <p>Level (dBuV/m): 117, 102.4, 87.8, 73.1, 58.5, 43.9, 29.3, 14.6</p> <p>Frequency (MHz): 2310, 2320, 2330, 2340, 2350, 2360, 2370, 2380, 2390, 2400</p> <p>Site : 03CH07-HY Condition : FCC CLASS-B (AVG) 3m HF-ANT_130829 VERTICAL RBW:1000.000kHz VBW:1.000kHz SWT:Auto Detector : Peak Project : 620405 Mode : 19</p>

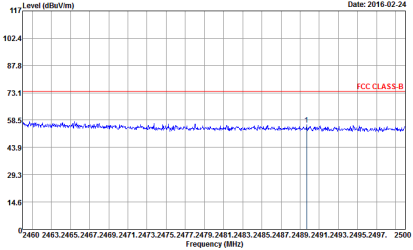
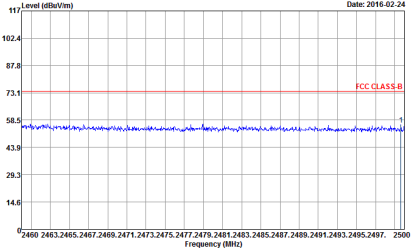
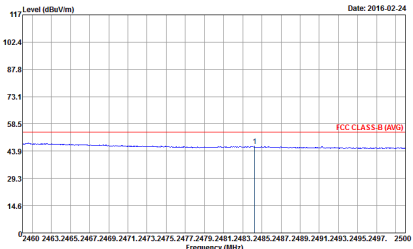
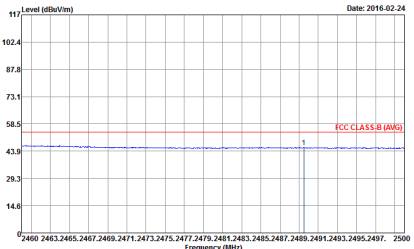

WIFI	2.4GHz 2400~2483.5MHz Band Edge @ 3m	
ANT	802.11g CH06 2437MHz - R	
1	Horizontal	Vertical
Peak	 <p>Date: 2016-02-24</p> <p>Level (dBuV/m)</p> <p>Frequency (MHz)</p> <p>FCC CLASS B</p> <p>Site : 03CH07-HY Condition : FCC CLASS-B 3m HF-ANT_130829 HORIZONTAL RBW:1000.000kHz VBW:3000.000kHz SWT:Auto Detector : Peak Project : 620405 Mode : 19</p>	 <p>Date: 2016-02-24</p> <p>Level (dBuV/m)</p> <p>Frequency (MHz)</p> <p>FCC CLASS B</p> <p>Site : 03CH07-HY Condition : FCC CLASS-B 3m HF-ANT_130829 VERTICAL RBW:1000.000kHz VBW:3000.000kHz SWT:Auto Detector : Peak Project : 620405 Mode : 19</p>
Avg.	 <p>Date: 2016-02-24</p> <p>Level (dBuV/m)</p> <p>Frequency (MHz)</p> <p>FCC CLASS-B (AVG)</p> <p>Site : 03CH07-HY Condition : FCC CLASS-B (AVG) 3m HF-ANT_130829 HORIZONTAL RBW:1000.000kHz VBW:1.000kHz SWT:Auto Detector : Peak Project : 620405 Mode : 19</p>	 <p>Date: 2016-02-24</p> <p>Level (dBuV/m)</p> <p>Frequency (MHz)</p> <p>FCC CLASS-B (AVG)</p> <p>Site : 03CH07-HY Condition : FCC CLASS-B (AVG) 3m HF-ANT_130829 VERTICAL RBW:1000.000kHz VBW:1.000kHz SWT:Auto Detector : Peak Project : 620405 Mode : 19</p>

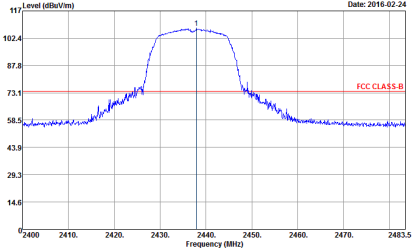
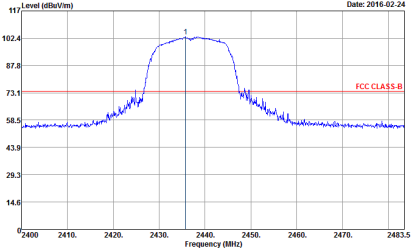
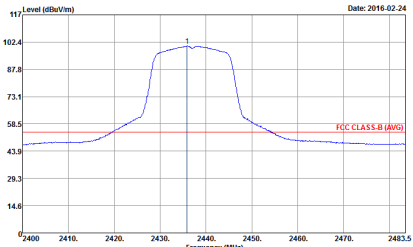
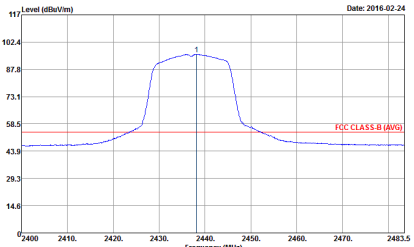

WIFI	2.4GHz 2400~2483.5MHz Fundamental @ 3m	
ANT	802.11g CH06 2437MHz	
1	Horizontal	Vertical
Peak	 <p>Date: 2016-02-24</p> <p>Site : 03CH07-HY Condition : FCC CLASS-B 3m HF-ANT_13829 HORIZONTAL RBW:1000.000kHz VBW:3000.000kHz SWT:Auto Detector : Peak Project : 620405 Mode : 19</p>	 <p>Date: 2016-02-24</p> <p>Site : 03CH07-HY Condition : FCC CLASS-B 3m HF-ANT_13829 VERTICAL RBW:1000.000kHz VBW:3000.000kHz SWT:Auto Detector : Peak Project : 620405 Mode : 19</p>
Avg.	 <p>Date: 2016-02-24</p> <p>Site : 03CH07-HY Condition : FCC CLASS-B (AVG) 3m HF-ANT_13829 HORIZONTAL RBW:1000.000kHz VBW:1.000kHz SWT:Auto Detector : Peak Project : 620405 Mode : 19</p>	 <p>Date: 2016-02-24</p> <p>Site : 03CH07-HY Condition : FCC CLASS-B (AVG) 3m HF-ANT_13829 VERTICAL RBW:1000.000kHz VBW:1.000kHz SWT:Auto Detector : Peak Project : 620405 Mode : 19</p>

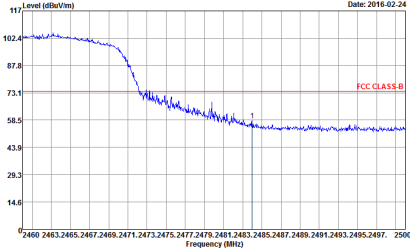
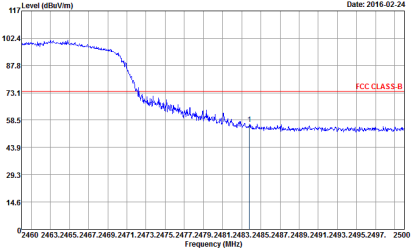
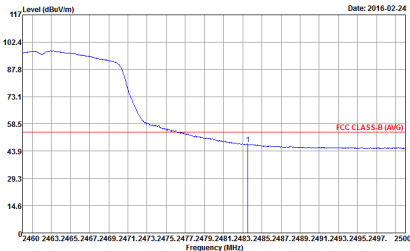
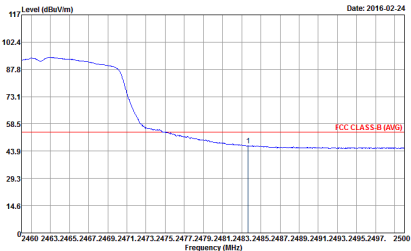

WIFI	2.4GHz 2400~2483.5MHz Band Edge @ 3m	
ANT	802.11g CH11 2462MHz	
1	Horizontal	Vertical
Peak	 <p>Date: 2016-02-24</p> <p>Site : 03CH07-HY Condition : FCC CLASS-B 3m HF-ANT_130829 HORIZONTAL RBW:1000.000kHz VBW:3000.000kHz SWT:Auto Detector : Peak Project : 620405 Mode : 20</p>	 <p>Date: 2016-02-24</p> <p>Site : 03CH07-HY Condition : FCC CLASS-B 3m HF-ANT_130829 VERTICAL RBW:1000.000kHz VBW:3000.000kHz SWT:Auto Detector : Peak Project : 620405 Mode : 20</p>
Avg.	 <p>Date: 2016-02-24</p> <p>Site : 03CH07-HY Condition : FCC CLASS-B (AVG) 3m HF-ANT_130829 HORIZONTAL RBW:1000.000kHz VBW:1.000kHz SWT:Auto Detector : Peak Project : 620405 Mode : 20</p>	 <p>Date: 2016-02-24</p> <p>Site : 03CH07-HY Condition : FCC CLASS-B (AVG) 3m HF-ANT_130829 VERTICAL RBW:1000.000kHz VBW:1.000kHz SWT:Auto Detector : Peak Project : 620405 Mode : 20</p>

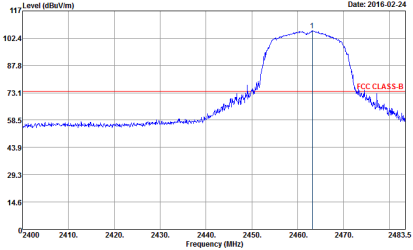
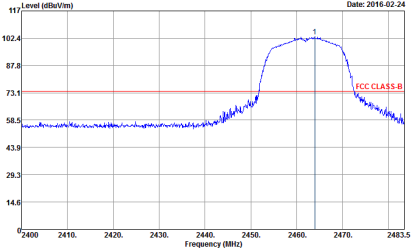
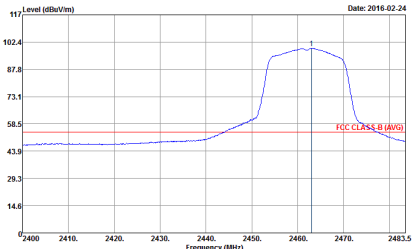
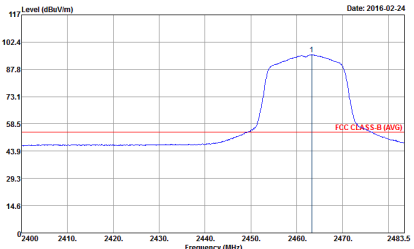

WIFI	2.4GHz 2400~2483.5MHz Fundamental @ 3m	
ANT	802.11g CH11 2462MHz	
1	Horizontal	Vertical
Peak	 <p>Date: 2016-02-24</p> <p>Site : 03CH07-HY Condition : FCC CLASS-B 3m HF-ANT_13829 HORIZONTAL RBW:1000.000kHz VBW:3000.000kHz SWT:Auto Detector : Peak Project : 620405 Mode : 20</p>	 <p>Date: 2016-02-24</p> <p>Site : 03CH07-HY Condition : FCC CLASS-B 3m HF-ANT_13829 VERTICAL RBW:1000.000kHz VBW:3000.000kHz SWT:Auto Detector : Peak Project : 620405 Mode : 20</p>
Avg.	 <p>Date: 2016-02-24</p> <p>Site : 03CH07-HY Condition : FCC CLASS-B (AVG) 3m HF-ANT_13829 HORIZONTAL RBW:1000.000kHz VBW:1.000kHz SWT:Auto Detector : Peak Project : 620405 Mode : 20</p>	 <p>Date: 2016-02-24</p> <p>Site : 03CH07-HY Condition : FCC CLASS-B (AVG) 3m HF-ANT_13829 VERTICAL RBW:1000.000kHz VBW:1.000kHz SWT:Auto Detector : Peak Project : 620405 Mode : 20</p>



2.4GHz 2400~2483.5MHz
WIFI 802.11n HT20 (Band Edge @ 3m)

WIFI	2.4GHz 2400~2483.5MHz Band Edge @ 3m	
ANT	802.11n HT20 CH01 2412MHz	
1	Horizontal	Vertical
Peak	<p>Site : 03CH07.HY Condition : FCC CLASS-B 3m HF-ANT_130829 HORIZONTAL RBW:1000.000kHz VBW:3000.000kHz SWT:Auto Detector : Peak Project : 620405 Mode : 21</p>	<p>Site : 03CH07.HY Condition : FCC CLASS-B 3m HF-ANT_130829 VERTICAL RBW:1000.000kHz VBW:3000.000kHz SWT:Auto Detector : Peak Project : 620405 Mode : 21</p>
Avg.	<p>Site : 03CH07.HY Condition : FCC CLASS-B (AVG) 3m HF-ANT_130829 HORIZONTAL RBW:1000.000kHz VBW:1.000kHz SWT:Auto Detector : Peak Project : 620405 Mode : 21</p>	<p>Site : 03CH07.HY Condition : FCC CLASS-B (AVG) 3m HF-ANT_130829 VERTICAL RBW:1000.000kHz VBW:1.000kHz SWT:Auto Detector : Peak Project : 620405 Mode : 21</p>

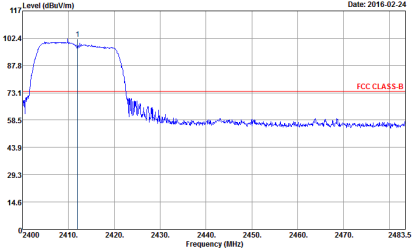
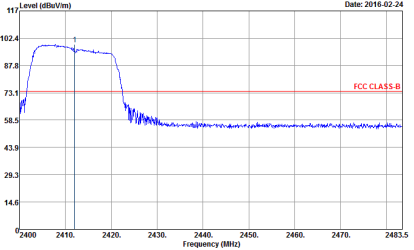
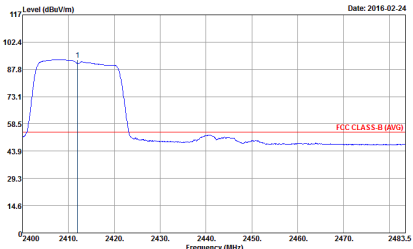
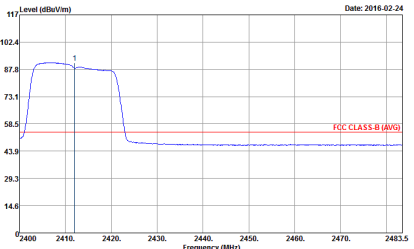

WIFI	2.4GHz 2400~2483.5MHz Fundamental @ 3m	
ANT	802.11n HT20 CH01 2412MHz	
1	Horizontal	Vertical
Peak	 <p>Date: 2016-02-24</p> <p>Site : 03CH07-HY Condition : FCC CLASS-B 3m HF-ANT_139829 HORIZONTAL RBW:1000.000kHz VBW:3000.000kHz SWT:Auto Detector : Peak Project : 620405 Mode : 21</p>	 <p>Date: 2016-02-24</p> <p>Site : 03CH07-HY Condition : FCC CLASS-B 3m HF-ANT_139829 VERTICAL RBW:1000.000kHz VBW:3000.000kHz SWT:Auto Detector : Peak Project : 620405 Mode : 21</p>
Avg.	 <p>Date: 2016-02-24</p> <p>Site : 03CH07-HY Condition : FCC CLASS-B (AVG) 3m HF-ANT_139829 HORIZONTAL RBW:1000.000kHz VBW:1.000kHz SWT:Auto Detector : Peak Project : 620405 Mode : 21</p>	 <p>Date: 2016-02-24</p> <p>Site : 03CH07-HY Condition : FCC CLASS-B (AVG) 3m HF-ANT_139829 VERTICAL RBW:1000.000kHz VBW:1.000kHz SWT:Auto Detector : Peak Project : 620405 Mode : 21</p>

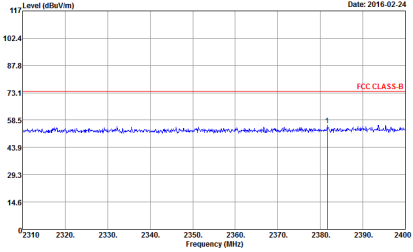
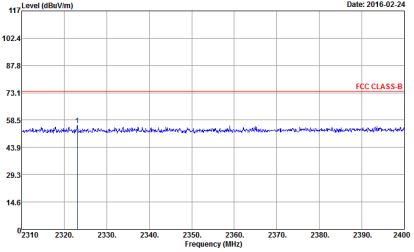
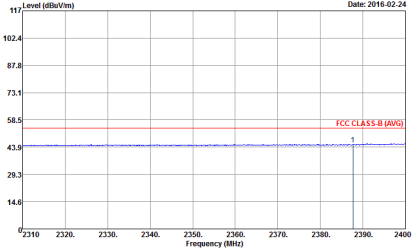
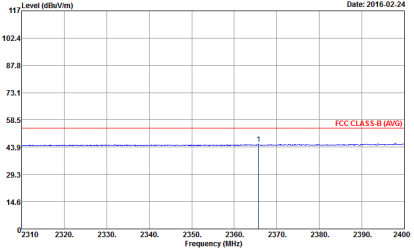

WIFI	2.4GHz 2400~2483.5MHz Band Edge @ 3m	
ANT	802.11n HT20 CH06 2437MHz - L	
1	Horizontal	Vertical
Peak	 <p>Date: 2016-02-24</p> <p>Site : 03CH07-HY Condition : FCC CLASS-B 3m HF-ANT_138829 HORIZONTAL RBW:1000.000kHz VBW:3000.000kHz SWT:Auto Detector : Peak Project : 620405 Mode : 22</p>	 <p>Date: 2016-02-24</p> <p>Site : 03CH07-HY Condition : FCC CLASS-B 3m HF-ANT_138829 VERTICAL RBW:1000.000kHz VBW:3000.000kHz SWT:Auto Detector : Peak Project : 620405 Mode : 22</p>
Avg.	 <p>Date: 2016-02-24</p> <p>Site : 03CH07-HY Condition : FCC CLASS-B (AVG) 3m HF-ANT_138829 HORIZONTAL RBW:1000.000kHz VBW:1.000kHz SWT:Auto Detector : Peak Project : 620405 Mode : 22</p>	 <p>Date: 2016-02-24</p> <p>Site : 03CH07-HY Condition : FCC CLASS-B (AVG) 3m HF-ANT_138829 VERTICAL RBW:1000.000kHz VBW:1.000kHz SWT:Auto Detector : Peak Project : 620405 Mode : 22</p>

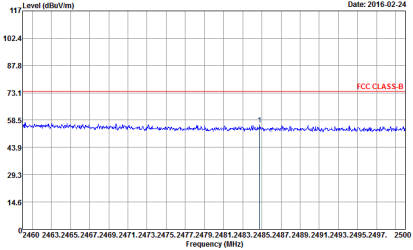
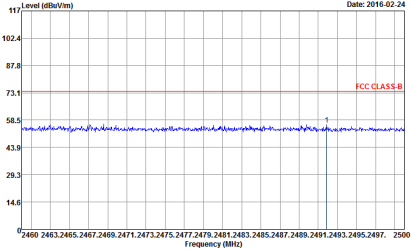
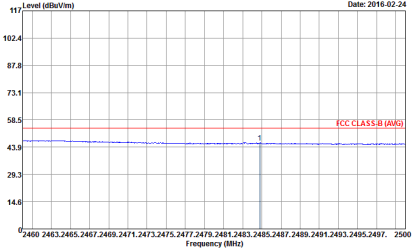
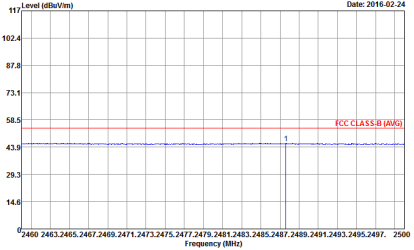

WIFI	2.4GHz 2400~2483.5MHz Band Edge @ 3m	
ANT	802.11n HT20 CH06 2437MHz - R	
1	Horizontal	Vertical
Peak	 <p>Date: 2016-02-24</p> <p>Site : 03CH07-HY Condition : FCC CLASS-B 3m HF-ANT_130829 HORIZONTAL RBW:1000.000kHz VBW:3000.000kHz SWT:Auto Detector : Peak Project : 620405 Mode : 22</p>	 <p>Date: 2016-02-24</p> <p>Site : 03CH07-HY Condition : FCC CLASS-B 3m HF-ANT_130829 VERTICAL RBW:1000.000kHz VBW:3000.000kHz SWT:Auto Detector : Peak Project : 620405 Mode : 22</p>
Avg.	 <p>Date: 2016-02-24</p> <p>Site : 03CH07-HY Condition : FCC CLASS-B (AVG) 3m HF-ANT_130829 HORIZONTAL RBW:1000.000kHz VBW:1.000kHz SWT:Auto Detector : Peak Project : 620405 Mode : 22</p>	 <p>Date: 2016-02-24</p> <p>Site : 03CH07-HY Condition : FCC CLASS-B (AVG) 3m HF-ANT_130829 VERTICAL RBW:1000.000kHz VBW:1.000kHz SWT:Auto Detector : Peak Project : 620405 Mode : 22</p>

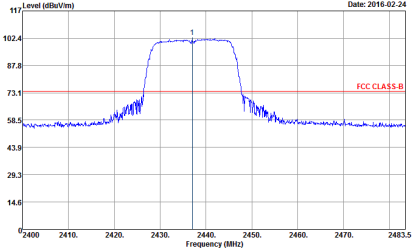
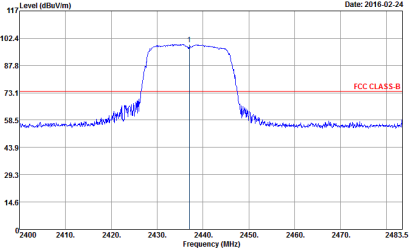
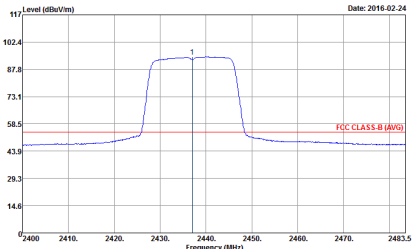
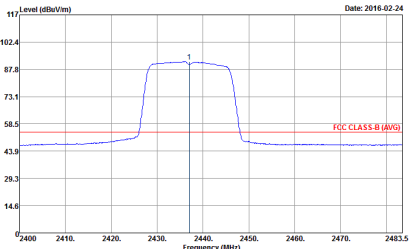

WIFI	2.4GHz 2400~2483.5MHz Fundamental @ 3m	
ANT	802.11n HT20 CH06 2437MHz	
1	Horizontal	Vertical
Peak	 <p>Date: 2016-02-24</p> <p>Site : 03CH07-HY Condition : FCC CLASS-B 3m HF-ANT_130829 HORIZONTAL RBW:1000.000kHz VBW:3000.000kHz SWT:Auto Detector : Peak Project : 620405 Mode : 22</p>	 <p>Date: 2016-02-24</p> <p>Site : 03CH07-HY Condition : FCC CLASS-B 3m HF-ANT_130829 VERTICAL RBW:1000.000kHz VBW:3000.000kHz SWT:Auto Detector : Peak Project : 620405 Mode : 22</p>
Avg.	 <p>Date: 2016-02-24</p> <p>Site : 03CH07-HY Condition : FCC CLASS-B (AVG) 3m HF-ANT_130829 HORIZONTAL RBW:1000.000kHz VBW:1.000kHz SWT:Auto Detector : Peak Project : 620405 Mode : 22</p>	 <p>Date: 2016-02-24</p> <p>Site : 03CH07-HY Condition : FCC CLASS-B (AVG) 3m HF-ANT_130829 VERTICAL RBW:1000.000kHz VBW:1.000kHz SWT:Auto Detector : Peak Project : 620405 Mode : 22</p>

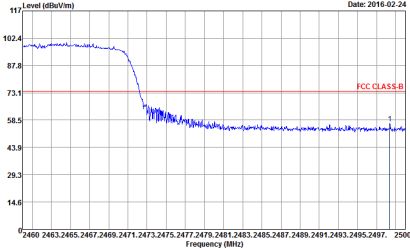
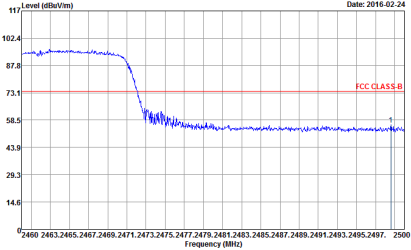
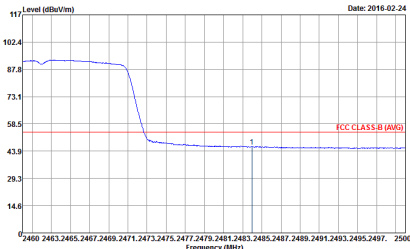
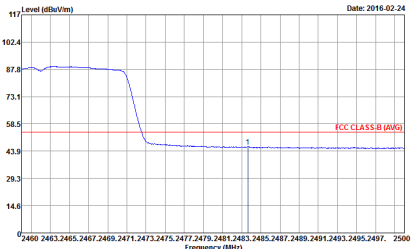

WIFI	2.4GHz 2400~2483.5MHz Band Edge @ 3m	
ANT	802.11n HT20 CH11 2462MHz	
1	Horizontal	Vertical
Peak	 <p>Date: 2016-02-24</p> <p>Level (dBuV/m) vs Frequency (MHz)</p> <p>FCC CLASS B</p> <p>Site : 03CH07-HY Condition : FCC CLASS-B 3m HF-ANT_130829 HORIZONTAL RBW:1000.000kHz VBW:3000.000kHz SWT:Auto Detector : Peak Project : 620405 Mode : 23</p>	 <p>Date: 2016-02-24</p> <p>Level (dBuV/m) vs Frequency (MHz)</p> <p>FCC CLASS B</p> <p>Site : 03CH07-HY Condition : FCC CLASS-B 3m HF-ANT_130829 VERTICAL RBW:1000.000kHz VBW:3000.000kHz SWT:Auto Detector : Peak Project : 620405 Mode : 23</p>
Avg.	 <p>Date: 2016-02-24</p> <p>Level (dBuV/m) vs Frequency (MHz)</p> <p>FCC CLASS-B (AVG)</p> <p>Site : 03CH07-HY Condition : FCC CLASS-B (AVG) 3m HF-ANT_130829 HORIZONTAL RBW:1000.000kHz VBW:1.000kHz SWT:Auto Detector : Peak Project : 620405 Mode : 23</p>	 <p>Date: 2016-02-24</p> <p>Level (dBuV/m) vs Frequency (MHz)</p> <p>FCC CLASS-B (AVG)</p> <p>Site : 03CH07-HY Condition : FCC CLASS-B (AVG) 3m HF-ANT_130829 VERTICAL RBW:1000.000kHz VBW:1.000kHz SWT:Auto Detector : Peak Project : 620405 Mode : 23</p>

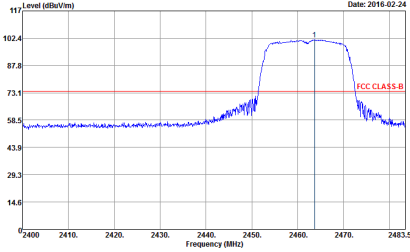
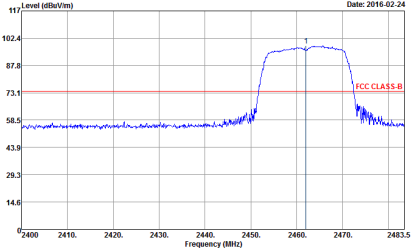
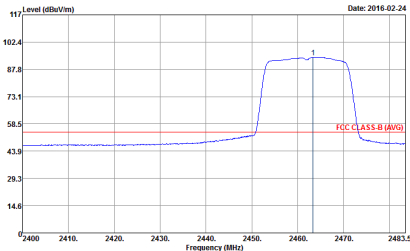
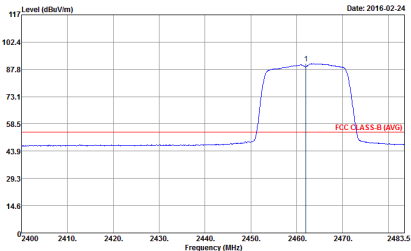

WIFI	2.4GHz 2400~2483.5MHz Fundamental @ 3m	
ANT	802.11n HT20 CH11 2462MHz	
1	Horizontal	Vertical
Peak	 <p>Site : 03CH07-HY Condition : FCC CLASS-B 3m HF-ANT_130829 HORIZONTAL RBW:1000.000kHz VBW:3000.000kHz SWT:Auto Detector : Peak Project : 620405 Mode : 23</p>	 <p>Site : 03CH07-HY Condition : FCC CLASS-B 3m HF-ANT_130829 VERTICAL RBW:1000.000kHz VBW:3000.000kHz SWT:Auto Detector : Peak Project : 620405 Mode : 23</p>
Avg.	 <p>Site : 03CH07-HY Condition : FCC CLASS-B (AVG) 3m HF-ANT_130829 HORIZONTAL RBW:1000.000kHz VBW:1.000kHz SWT:Auto Detector : Peak Project : 620405 Mode : 23</p>	 <p>Site : 03CH07-HY Condition : FCC CLASS-B (AVG) 3m HF-ANT_130829 VERTICAL RBW:1000.000kHz VBW:1.000kHz SWT:Auto Detector : Peak Project : 620405 Mode : 23</p>



2.4GHz 2400~2483.5MHz
WIFI 802.11n HT40 (Band Edge @ 3m)

WIFI	2.4GHz 2400~2483.5MHz Band Edge @ 3m	
ANT	802.11n HT40 CH03 2422MHz - L	
1	Horizontal	Vertical
Peak	<p>Site : 03CH07-HY Condition : FCC CLASS-B 3m HF-ANT_130829 HORIZONTAL Detector : Peak Project : 620405 Mode : 24</p>	<p>Site : 03CH07-HY Condition : FCC CLASS-B 3m HF-ANT_130829 VERTICAL Detector : Peak Project : 620405 Mode : 24</p>
Avg.	<p>Site : 03CH07-HY Condition : FCC CLASS-B (AVG) 3m HF-ANT_130829 HORIZONTAL Detector : Peak Project : 620405 Mode : 24</p>	<p>Site : 03CH07-HY Condition : FCC CLASS-B (AVG) 3m HF-ANT_130829 VERTICAL Detector : Peak Project : 620405 Mode : 24</p>

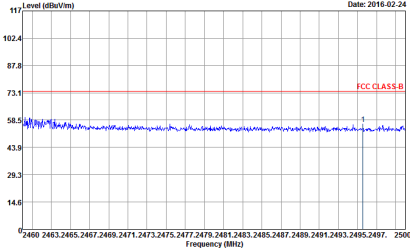
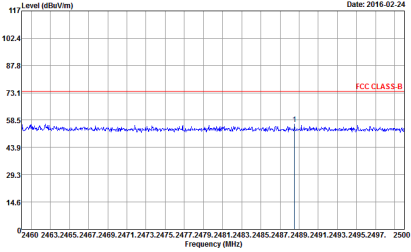
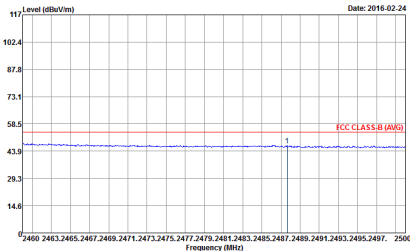
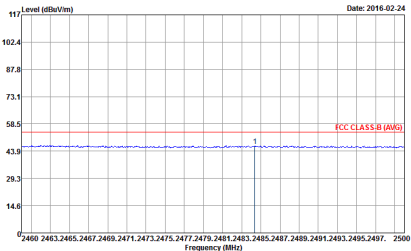

WIFI	2.4GHz 2400~2483.5MHz Band Edge @ 3m	
ANT	802.11n HT40 CH03 2422MHz - R	
1	Horizontal	Vertical
Peak	 <p>Date: 2016-02-24</p> <p>Site : 03CH07-HY Condition : FCC CLASS-B 3m HF-ANT_130829 HORIZONTAL RBW:1000.000kHz VBW:3000.000kHz SWT:Auto Detector : Peak Project : 620405 Mode : 24</p>	 <p>Date: 2016-02-24</p> <p>Site : 03CH07-HY Condition : FCC CLASS-B 3m HF-ANT_130829 VERTICAL RBW:1000.000kHz VBW:3000.000kHz SWT:Auto Detector : Peak Project : 620405 Mode : 24</p>
Avg.	 <p>Date: 2016-02-24</p> <p>Site : 03CH07-HY Condition : FCC CLASS-B (AVG) 3m HF-ANT_130829 HORIZONTAL RBW:1000.000kHz VBW:3.000kHz SWT:Auto Detector : Peak Project : 620405 Mode : 24</p>	 <p>Date: 2016-02-24</p> <p>Site : 03CH07-HY Condition : FCC CLASS-B (AVG) 3m HF-ANT_130829 VERTICAL RBW:1000.000kHz VBW:3.000kHz SWT:Auto Detector : Peak Project : 620405 Mode : 24</p>

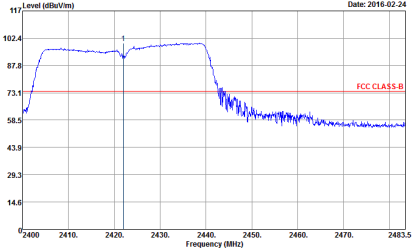
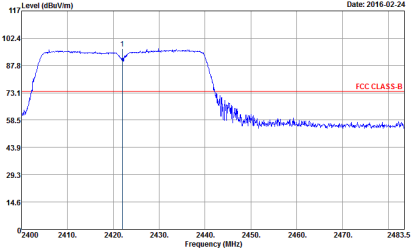
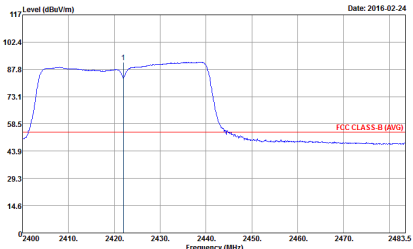
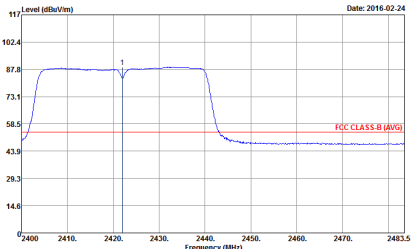

WIFI	2.4GHz 2400~2483.5MHz Fundamental @ 3m	
ANT	802.11n HT40 CH03 2422MHz	
1	Horizontal	Vertical
Peak	 <p>Date: 2016-02-24</p> <p>Site : 03CH07-HY Condition : FCC CLASS-B 3m HF-ANT_130829 HORIZONTAL RBW:1000.000kHz VBW:3000.000kHz SWT:Auto Detector : Peak Project : 620405 Mode : 24</p>	 <p>Date: 2016-02-24</p> <p>Site : 03CH07-HY Condition : FCC CLASS-B 3m HF-ANT_130829 VERTICAL RBW:1000.000kHz VBW:3000.000kHz SWT:Auto Detector : Peak Project : 620405 Mode : 24</p>
Avg.	 <p>Date: 2016-02-24</p> <p>Site : 03CH07-HY Condition : FCC CLASS-B (AVG) 3m HF-ANT_130829 HORIZONTAL RBW:1000.000kHz VBW:3.000kHz SWT:Auto Detector : Peak Project : 620405 Mode : 24</p>	 <p>Date: 2016-02-24</p> <p>Site : 03CH07-HY Condition : FCC CLASS-B (AVG) 3m HF-ANT_130829 VERTICAL RBW:1000.000kHz VBW:3.000kHz SWT:Auto Detector : Peak Project : 620405 Mode : 24</p>

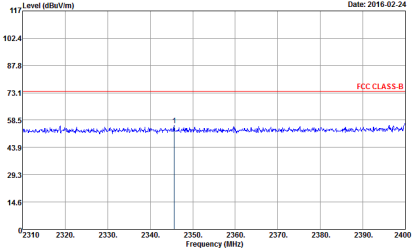
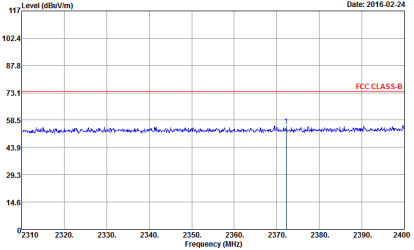
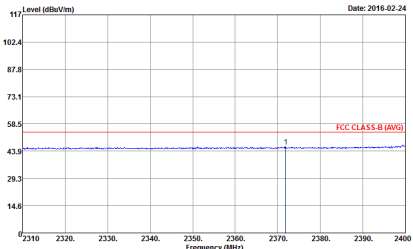
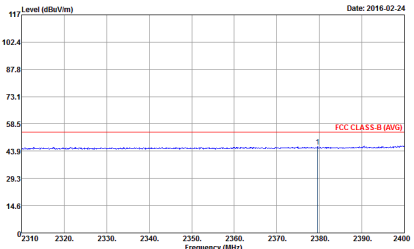

WIFI	2.4GHz 2400~2483.5MHz Band Edge @ 3m	
ANT	802.11n HT40 CH06 2437MHz - L	
1	Horizontal	Vertical
Peak	 <p>Date: 2016-02-24</p> <p>Level (dBuV/m): 117, 102.4, 87.8, 73.1, 58.5, 43.9, 29.3, 14.6</p> <p>Frequency (MHz): 2310, 2320, 2330, 2340, 2350, 2360, 2370, 2380, 2390, 2400</p> <p>Site : 03CH07-HY Condition : FCC CLASS-B 3m HF-ANT_130829 HORIZONTAL RBW:1000.000kHz VBW:3000.000kHz SWT:Auto Detector : Peak Project : 620405 Mode : 25</p>	 <p>Date: 2016-02-24</p> <p>Level (dBuV/m): 117, 102.4, 87.8, 73.1, 58.5, 43.9, 29.3, 14.6</p> <p>Frequency (MHz): 2310, 2320, 2330, 2340, 2350, 2360, 2370, 2380, 2390, 2400</p> <p>Site : 03CH07-HY Condition : FCC CLASS-B 3m HF-ANT_130829 VERTICAL RBW:1000.000kHz VBW:3000.000kHz SWT:Auto Detector : Peak Project : 620405 Mode : 25</p>
Avg.	 <p>Date: 2016-02-24</p> <p>Level (dBuV/m): 117, 102.4, 87.8, 73.1, 58.5, 43.9, 29.3, 14.6</p> <p>Frequency (MHz): 2310, 2320, 2330, 2340, 2350, 2360, 2370, 2380, 2390, 2400</p> <p>Site : 03CH07-HY Condition : FCC CLASS-B (AVG) 3m HF-ANT_130829 HORIZONTAL RBW:1000.000kHz VBW:3.000kHz SWT:Auto Detector : Peak Project : 620405 Mode : 25</p>	 <p>Date: 2016-02-24</p> <p>Level (dBuV/m): 117, 102.4, 87.8, 73.1, 58.5, 43.9, 29.3, 14.6</p> <p>Frequency (MHz): 2310, 2320, 2330, 2340, 2350, 2360, 2370, 2380, 2390, 2400</p> <p>Site : 03CH07-HY Condition : FCC CLASS-B (AVG) 3m HF-ANT_130829 VERTICAL RBW:1000.000kHz VBW:3.000kHz SWT:Auto Detector : Peak Project : 620405 Mode : 25</p>

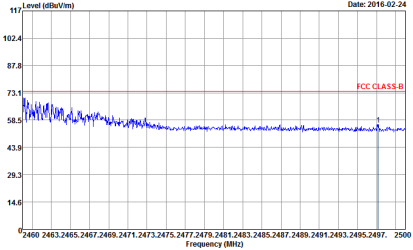
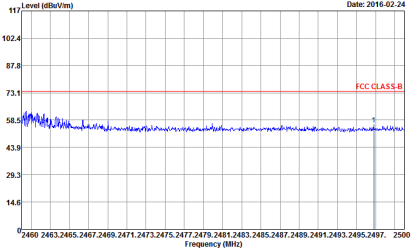
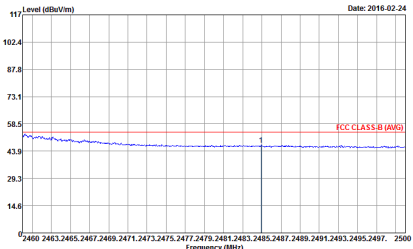
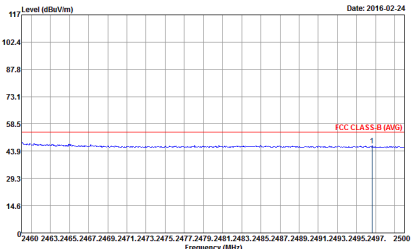

WIFI	2.4GHz 2400~2483.5MHz Band Edge @ 3m	
ANT	802.11n HT40 CH06 2437MHz - R	
1	Horizontal	Vertical
Peak	 <p>Date: 2016-02-24</p> <p>Level (dBuV/m)</p> <p>Frequency (MHz)</p> <p>FCC CLASS B</p> <p>Site : 03CH07-HY Condition : FCC CLASS-B 3m HF-ANT_130829 HORIZONTAL RBW:1000.000kHz VBW:3000.000kHz SWT:Auto Detector : Peak Project : 620405 Mode : 25</p>	 <p>Date: 2016-02-24</p> <p>Level (dBuV/m)</p> <p>Frequency (MHz)</p> <p>FCC CLASS B</p> <p>Site : 03CH07-HY Condition : FCC CLASS-B 3m HF-ANT_130829 VERTICAL RBW:1000.000kHz VBW:3000.000kHz SWT:Auto Detector : Peak Project : 620405 Mode : 25</p>
Avg.	 <p>Date: 2016-02-24</p> <p>Level (dBuV/m)</p> <p>Frequency (MHz)</p> <p>FCC CLASS-B (AVG)</p> <p>Site : 03CH07-HY Condition : FCC CLASS-B (AVG) 3m HF-ANT_130829 HORIZONTAL RBW:1000.000kHz VBW:3.000kHz SWT:Auto Detector : Peak Project : 620405 Mode : 25</p>	 <p>Date: 2016-02-24</p> <p>Level (dBuV/m)</p> <p>Frequency (MHz)</p> <p>FCC CLASS-B (AVG)</p> <p>Site : 03CH07-HY Condition : FCC CLASS-B (AVG) 3m HF-ANT_130829 VERTICAL RBW:1000.000kHz VBW:3.000kHz SWT:Auto Detector : Peak Project : 620405 Mode : 25</p>

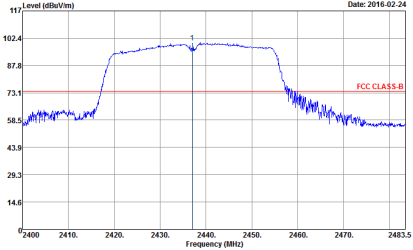
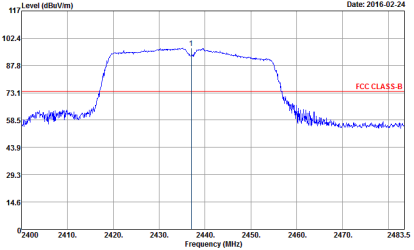
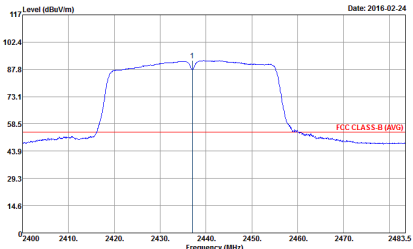
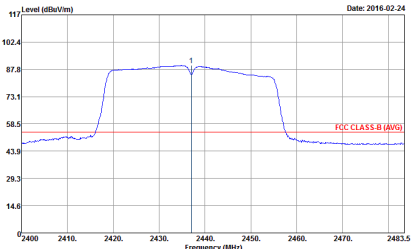

WIFI	2.4GHz 2400~2483.5MHz Fundamental @ 3m	
ANT	802.11n HT40 CH06 2437MHz	
1	Horizontal	Vertical
Peak	 <p>Date: 2016-02-24</p> <p>Site : 03CH07-HY Condition : FCC CLASS-B 3m HF-ANT_130829 HORIZONTAL RBW:1000.000kHz VBW:3000.000kHz SWT:Auto Detector : Peak Project : 620405 Mode : 25</p>	 <p>Date: 2016-02-24</p> <p>Site : 03CH07-HY Condition : FCC CLASS-B 3m HF-ANT_130829 VERTICAL RBW:1000.000kHz VBW:3000.000kHz SWT:Auto Detector : Peak Project : 620405 Mode : 25</p>
Avg.	 <p>Date: 2016-02-24</p> <p>Site : 03CH07-HY Condition : FCC CLASS-B (AVG) 3m HF-ANT_130829 HORIZONTAL RBW:1000.000kHz VBW:3.000kHz SWT:Auto Detector : Peak Project : 620405 Mode : 25</p>	 <p>Date: 2016-02-24</p> <p>Site : 03CH07-HY Condition : FCC CLASS-B (AVG) 3m HF-ANT_130829 VERTICAL RBW:1000.000kHz VBW:3.000kHz SWT:Auto Detector : Peak Project : 620405 Mode : 25</p>

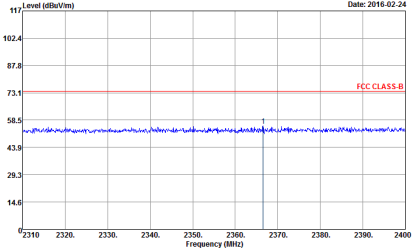
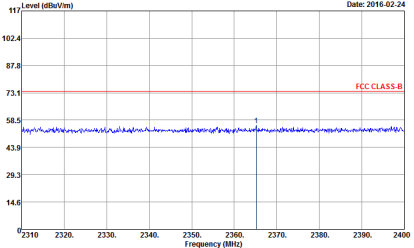
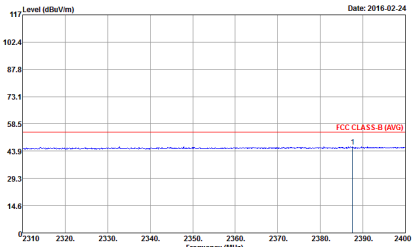
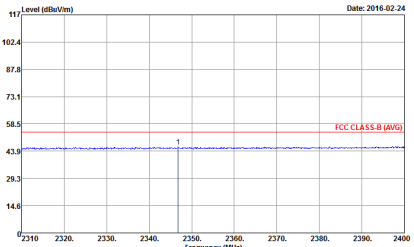

WIFI	2.4GHz 2400~2483.5MHz Band Edge @ 3m	
ANT	802.11n HT40 CH09 2452MHz - L	
1	Horizontal	Vertical
Peak	 <p>Date: 2016-02-24</p> <p>Level (dBuV/m): 117, 102.4, 87.8, 73.1, 58.5, 43.9, 29.3, 14.6</p> <p>Frequency (MHz): 2310, 2320, 2330, 2340, 2350, 2360, 2370, 2380, 2390, 2400</p> <p>Site : 03CH07-HY Condition : FCC CLASS-B 3m HF-ANT_138829 HORIZONTAL RBW:1000.000kHz VBW:3000.000kHz SWT:Auto Detector : Peak Project : 620405 Mode : 26</p>	 <p>Date: 2016-02-24</p> <p>Level (dBuV/m): 117, 102.4, 87.8, 73.1, 58.5, 43.9, 29.3, 14.6</p> <p>Frequency (MHz): 2310, 2320, 2330, 2340, 2350, 2360, 2370, 2380, 2390, 2400</p> <p>Site : 03CH07-HY Condition : FCC CLASS-B 3m HF-ANT_138829 VERTICAL RBW:1000.000kHz VBW:3000.000kHz SWT:Auto Detector : Peak Project : 620405 Mode : 26</p>
Avg.	 <p>Date: 2016-02-24</p> <p>Level (dBuV/m): 117, 102.4, 87.8, 73.1, 58.5, 43.9, 29.3, 14.6</p> <p>Frequency (MHz): 2310, 2320, 2330, 2340, 2350, 2360, 2370, 2380, 2390, 2400</p> <p>Site : 03CH07-HY Condition : FCC CLASS-B (AVG) 3m HF-ANT_138829 HORIZONTAL RBW:1000.000kHz VBW:3.000kHz SWT:Auto Detector : Peak Project : 620405 Mode : 26</p>	 <p>Date: 2016-02-24</p> <p>Level (dBuV/m): 117, 102.4, 87.8, 73.1, 58.5, 43.9, 29.3, 14.6</p> <p>Frequency (MHz): 2310, 2320, 2330, 2340, 2350, 2360, 2370, 2380, 2390, 2400</p> <p>Site : 03CH07-HY Condition : FCC CLASS-B (AVG) 3m HF-ANT_138829 VERTICAL RBW:1000.000kHz VBW:3.000kHz SWT:Auto Detector : Peak Project : 620405 Mode : 26</p>

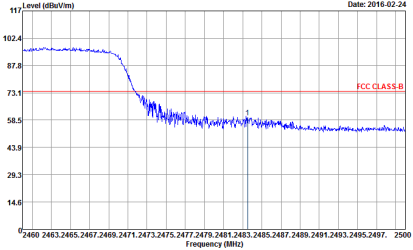
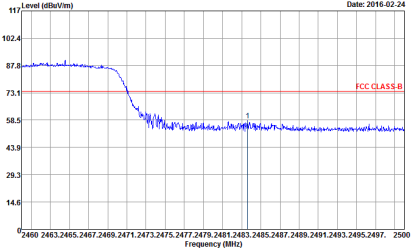
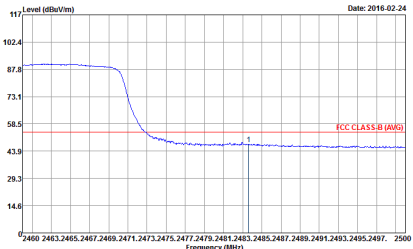
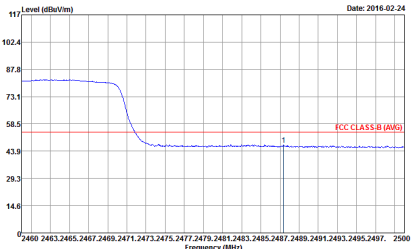

WIFI	2.4GHz 2400~2483.5MHz Band Edge @ 3m	
ANT	802.11n HT40 CH09 2452MHz - R	
1	Horizontal	Vertical
Peak	 <p>Site : 03CH07-HY Condition : FCC CLASS-B 3m HF-ANT_130829 HORIZONTAL RBW:1000.000kHz VBW:3000.000kHz SWT:Auto Detector : Peak Project : 620405 Mode : 26</p>	 <p>Site : 03CH07-HY Condition : FCC CLASS-B 3m HF-ANT_130829 VERTICAL RBW:1000.000kHz VBW:3000.000kHz SWT:Auto Detector : Peak Project : 620405 Mode : 26</p>
Avg.	 <p>Site : 03CH07-HY Condition : FCC CLASS-B (AVG) 3m HF-ANT_130829 HORIZONTAL RBW:1000.000kHz VBW:3.000kHz SWT:Auto Detector : Peak Project : 620405 Mode : 26</p>	 <p>Site : 03CH07-HY Condition : FCC CLASS-B (AVG) 3m HF-ANT_130829 VERTICAL RBW:1000.000kHz VBW:3.000kHz SWT:Auto Detector : Peak Project : 620405 Mode : 26</p>

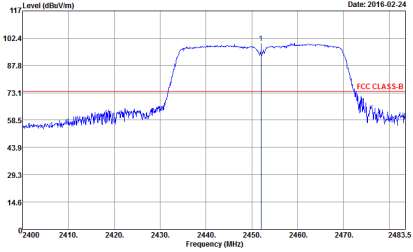
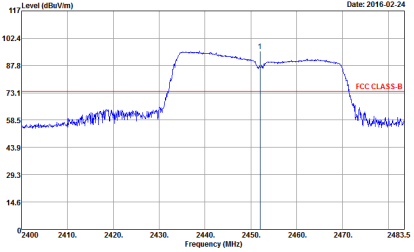
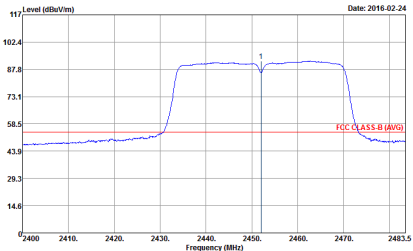
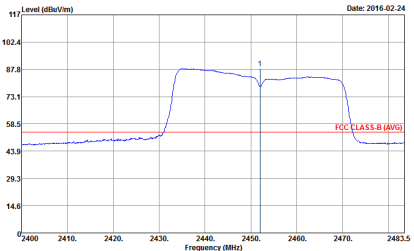

WIFI	2.4GHz 2400~2483.5MHz Fundamental @ 3m	
ANT	802.11n HT40 CH09 2452MHz	
1	Horizontal	Vertical
Peak	 <p>Date: 2016-02-24</p> <p>Site : 03CH07-HY Condition : FCC CLASS-B 3m HF-ANT_13829 HORIZONTAL RBW:1000.000kHz VBW:3000.000kHz SWT:Auto Detector : Peak Project : 620405 Mode : 26</p>	 <p>Date: 2016-02-24</p> <p>Site : 03CH07-HY Condition : FCC CLASS-B 3m HF-ANT_13829 VERTICAL RBW:1000.000kHz VBW:3000.000kHz SWT:Auto Detector : Peak Project : 620405 Mode : 26</p>
Avg.	 <p>Date: 2016-02-24</p> <p>Site : 03CH07-HY Condition : FCC CLASS-B (AVG) 3m HF-ANT_13829 HORIZONTAL RBW:1000.000kHz VBW:3.000kHz SWT:Auto Detector : Peak Project : 620405 Mode : 26</p>	 <p>Date: 2016-02-24</p> <p>Site : 03CH07-HY Condition : FCC CLASS-B (AVG) 3m HF-ANT_13829 VERTICAL RBW:1000.000kHz VBW:3.000kHz SWT:Auto Detector : Peak Project : 620405 Mode : 26</p>

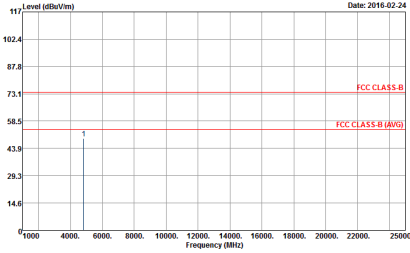
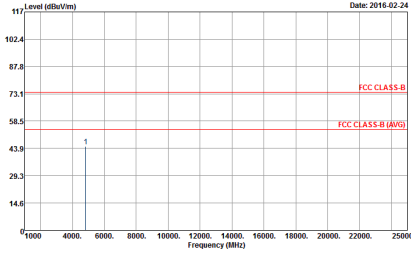

2.4GHz 2400~2483.5MHz
WIFI 802.11b (Harmonic @ 3m)

WIFI	2.4GHz 2400~2483.5MHz Harmonic @ 3m	
ANT	802.11b CH01 2412MHz	
1	Horizontal	Vertical
Peak Avg.	 <p>Site : 03CH074Y Condition : FCC CLASS-B 3m SHF-EHF_131029 HORIZONTAL Detector : Peak Project : 620405 Mode : 15</p>	 <p>Site : 03CH074Y Condition : FCC CLASS-B 3m SHF-EHF_131029 VERTICAL Detector : Peak Project : 620405 Mode : 15</p>

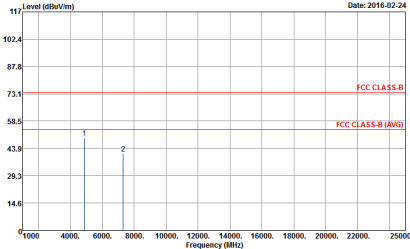
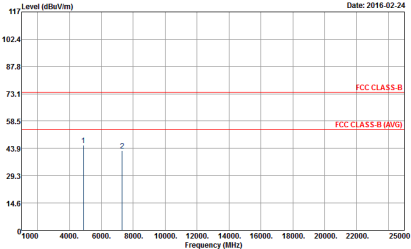

WIFI	2.4GHz 2400~2483.5MHz Harmonic @ 3m	
ANT	802.11b CH06 2437MHz	
1	Horizontal	Vertical
Peak Avg.	 <p>Site : 03CH074HY Condition : FCC CLASS-B 3m SHF-EHF_131029 HORIZONTAL Detector : Peak Project : 620405 Mode : 15</p>	 <p>Site : 03CH074HY Condition : FCC CLASS-B 3m SHF-EHF_131029 VERTICAL Detector : Peak Project : 620405 Mode : 15</p>

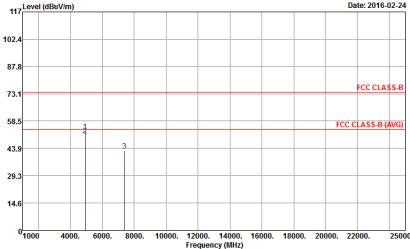
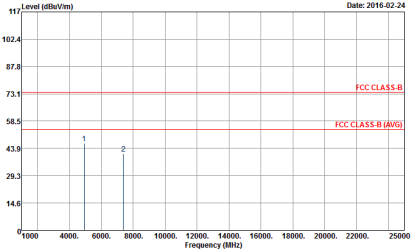

WIFI	2.4GHz 2400~2483.5MHz Harmonic @ 3m	
ANT	802.11b CH11 2462MHz	
1	Horizontal	Vertical
Peak Avg.	 <p>Site : 03CH074HY Condition : FCC CLASS-B 3m SHF-EHF_131029 HORIZONTAL Detector : Peak Project : 620405 Mode : IT</p>	 <p>Site : 03CH074HY Condition : FCC CLASS-B 3m SHF-EHF_131029 VERTICAL Detector : Peak Project : 620405 Mode : IT</p>



2.4GHz 2400~2483.5MHz
WIFI 802.11g (Harmonic @ 3m)

Table with 2 columns: Horizontal and Vertical. Each column contains a graph of Level (dBuV/m) vs Frequency (MHz) with FCC CLASS-B and FCC CLASS-B (AVG) limits. Includes metadata like Site, Condition, Detector, Project, and Mode.

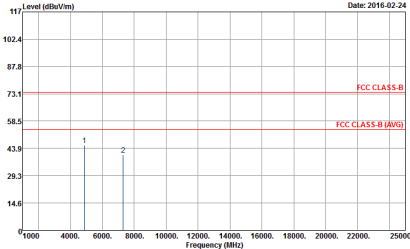
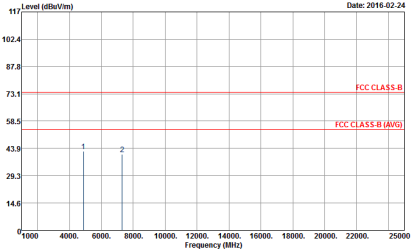

WIFI	2.4GHz 2400~2483.5MHz Harmonic @ 3m	
ANT	802.11g CH06 2437MHz	
1	Horizontal	Vertical
Peak Avg.	 <p>Site : 03CH074HY Condition : FCC CLASS-B 3m SHF-EHF_131029 HORIZONTAL Detector : Peak Project : 620405 Mode : 19</p>	 <p>Site : 03CH074HY Condition : FCC CLASS-B 3m SHF-EHF_131029 VERTICAL Detector : Peak Project : 620405 Mode : 19</p>

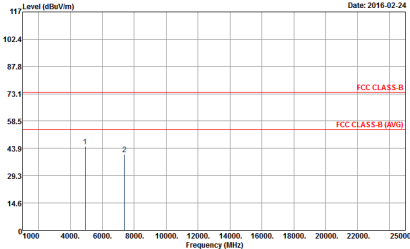
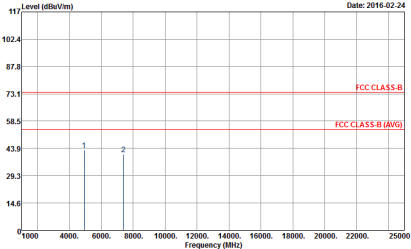

WIFI	2.4GHz 2400~2483.5MHz Harmonic @ 3m	
ANT	802.11g CH11 2462MHz	
1	Horizontal	Vertical
Peak Avg.	 <p>Site : 03CH074HY Condition : FCC CLASS-B 3m SHF-EHF_131029 HORIZONTAL Detector : Peak Project : 620405 Mode : 20</p>	 <p>Site : 03CH074HY Condition : FCC CLASS-B 3m SHF-EHF_131029 VERTICAL Detector : Peak Project : 620405 Mode : 20</p>

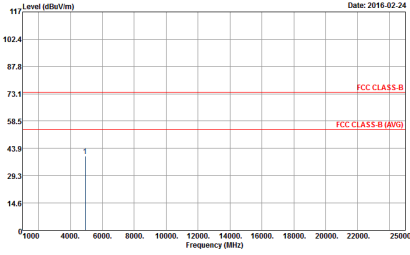
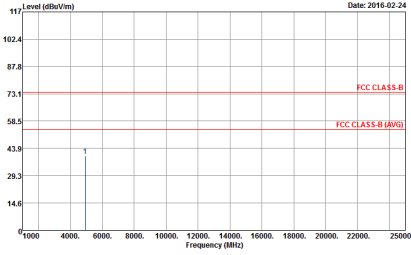

2.4GHz 2400~2483.5MHz
WIFI 802.11n HT20 (Harmonic @ 3m)

WIFI	2.4GHz 2400~2483.5MHz Harmonic @ 3m	
ANT	802.11n HT20 CH01 2412MHz	
1	Horizontal	Vertical
Peak Avg.	 <p>Site : 03CH074Y Condition : FCC CLASS-B 3m SHF-EHF_131029 HORIZONTAL Detector : Peak Project : 620405 Mode : 21</p>	 <p>Site : 03CH074Y Condition : FCC CLASS-B 3m SHF-EHF_131029 VERTICAL Detector : Peak Project : 620405 Mode : 21</p>

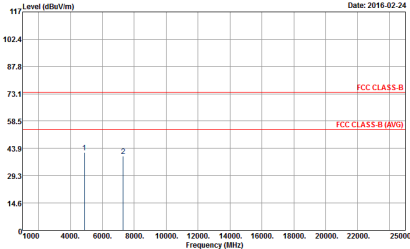
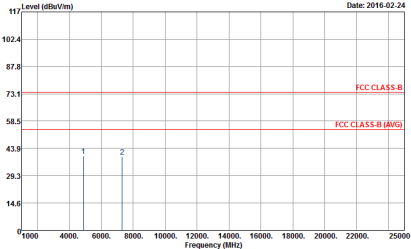

WIFI	2.4GHz 2400~2483.5MHz Harmonic @ 3m	
ANT	802.11n HT20 CH06 2437MHz	
1	Horizontal	Vertical
Peak Avg.	 <p>Site : 03CH074HY Condition : FCC CLASS-B 3m SHF-EHF_131029 HORIZONTAL Detector : Peak Project : 620405 Mode : 22</p>	 <p>Site : 03CH074HY Condition : FCC CLASS-B 3m SHF-EHF_131029 VERTICAL Detector : Peak Project : 620405 Mode : 22</p>

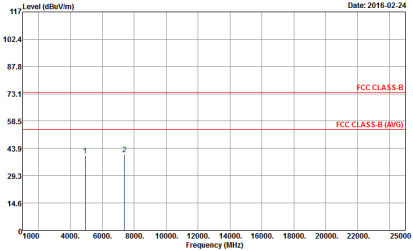
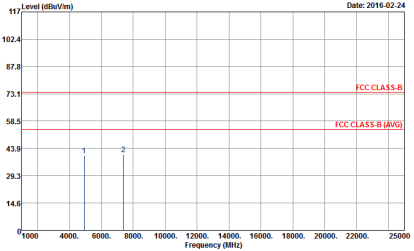

WIFI	2.4GHz 2400~2483.5MHz Harmonic @ 3m	
ANT	802.11n HT20 CH11 2462MHz	
1	Horizontal	Vertical
<p>Peak</p> <p>Avg.</p>	 <p>Site : 03CH074HY Condition : FCC CLASS-B 3m SHF-EHF_131029 HORIZONTAL Detector : Peak Project : 620405 Mode : 23</p>	 <p>Site : 03CH074HY Condition : FCC CLASS-B 3m SHF-EHF_131029 VERTICAL Detector : Peak Project : 620405 Mode : 23</p>



2.4GHz 2400~2483.5MHz
WIFI 802.11n HT40 (Harmonic @ 3m)

Table with 2 columns: Horizontal and Vertical. Each column contains a graph of Level (dBuV/m) vs Frequency (MHz) with FCC CLASS-B and FCC CLASS-B (AVG) limits. Includes metadata like Site, Condition, Detector, Project, and Mode.

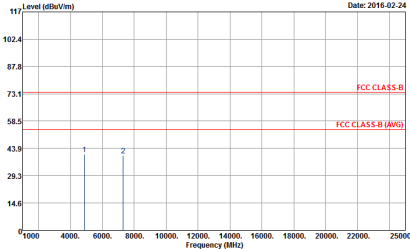
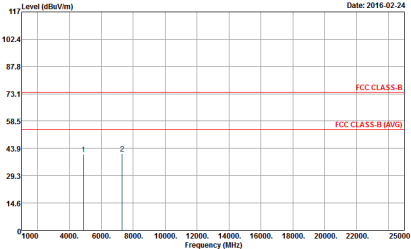

WIFI	2.4GHz 2400~2483.5MHz Harmonic @ 3m	
ANT	802.11n HT40 CH06 2437MHz	
1	Horizontal	Vertical
Peak Avg.	 <p>Site : 03CH074HY Condition : FCC CLASS-B 3m SHF-EHF_131029 HORIZONTAL Detector : Peak Project : 620405 Mode : 25</p>	 <p>Site : 03CH074HY Condition : FCC CLASS-B 3m SHF-EHF_131029 VERTICAL Detector : Peak Project : 620405 Mode : 25</p>

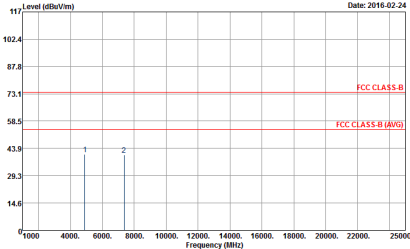
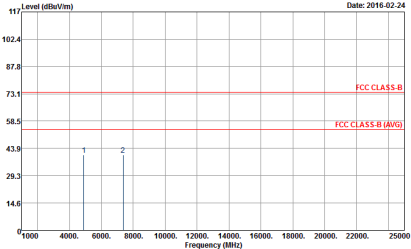

WIFI	2.4GHz 2400~2483.5MHz Harmonic @ 3m	
ANT	802.11n HT40 CH09 2452MHz	
1	Horizontal	Vertical
Peak Avg.	 <p>Site : 03CH074HY Condition : FCC CLASS-B 3m SHF-EHF_131029 HORIZONTAL Detector : Peak Project : 620405 Mode : 25</p>	 <p>Site : 03CH074HY Condition : FCC CLASS-B 3m SHF-EHF_131029 VERTICAL Detector : Peak Project : 620405 Mode : 25</p>



Emission below 1GHz
2.4GHz WIFI 802.11b (LF)

WIFI	2.4GHz 2400~2483.5MHz	
ANT	802.11b LF	
1	Horizontal	Vertical
QP / Peak	<p>Site : 03CH074HY Condition : FCC CLASS-B 3m LF-ANT:35419(6) HORIZONTAL Detector : Peak Project : 620405 Mode : 27</p>	<p>Site : 03CH074HY Condition : FCC CLASS-B 3m LF-ANT:35419(6) VERTICAL Detector : Peak Project : 620405 Mode : 27</p>



Emission below 1GHz
2.4GHz WIFI 802.11g (LF)

WIFI	2.4GHz 2400~2483.5MHz	
ANT	802.11g LF	
1	Horizontal	Vertical
QP / Peak	<p>Site : 03CH07.HY Condition : FCC CLASS B 3m LF-ANT:35419(6) HORIZONTAL Detector : Peak Project : 620405 Mode : 28</p>	<p>Site : 03CH07.HY Condition : FCC CLASS B 3m LF-ANT:35419(6) VERTICAL Detector : Peak Project : 620405 Mode : 28</p>



Emission below 1GHz
2.4GHz WIFI 802.11n HT20 (LF)

Table with 2 columns: Horizontal and Vertical. Row 1: WIFI 2.4GHz 2400~2483.5MHz. Row 2: ANT 802.11n HT20 LF. Row 3: 1. Row 4: QP / Peak. Each plot shows Level (dBuV/m) vs Frequency (MHz) with FCC CLASS B limits and test data points.



Emission below 1GHz
2.4GHz WIFI 802.11n HT40 (LF)

WIFI	2.4GHz 2400~2483.5MHz	
ANT	802.11n HT40 LF	
1	Horizontal	Vertical
QP / Peak	<p>Site : 03CH07.HY Condition : FCC CLASS B 3m LF-ANT:35419(6) HORIZONTAL Detector : Peak Project : 620405 Mode : 30</p>	<p>Site : 03CH07.HY Condition : FCC CLASS B 3m LF-ANT:35419(6) VERTICAL Detector : Peak Project : 620405 Mode : 30</p>