



FCC RF Test Report

APPLICANT : Sony Mobile Communications Inc.
EQUIPMENT : GSM/WCDMA/LTE Phone + Bluetooth,
DTS/UNII a/b/g/n/ac, ANT+, and NFC
BRAND NAME : Sony
FCC ID : PY7-PM0903
STANDARD : FCC 47 CFR Part 2, 22(H), 24(E)
CLASSIFICATION : PCS Licensed Transmitter Held to Ear (PCE)

The product was received on Jul. 16, 2015 and testing was completed on Aug. 25, 2015. We, SPORTON INTERNATIONAL INC., would like to declare that the tested sample has been evaluated in accordance with the test procedures given in ANSI / TIA / EIA-603-C-2004 and has been in compliance with the applicable technical standards.

The test results in this report apply exclusively to the tested model / sample. Without written approval of SPORTON INTERNATIONAL INC., the test report shall not be reproduced except in full.

Reviewed by: Joseph Lin / Supervisor

Approved by: Jones Tsai / Manager



SPORTON INTERNATIONAL INC.

No. 52, Hwa Ya 1st Rd., Hwa Ya Technology Park, Kwei-Shan District, Tao Yuan City, Taiwan, R.O.C.

SPORTON INTERNATIONAL INC.

TEL : 886-3-327-3456

FAX : 886-3-328-4978

FCC ID : PY7-PM0903

Page Number : 1 of 24

Report Issued Date : Sep. 14, 2015

Report Version : Rev. 01

Report Template No.: BU5-FG22/24 Version 1.0



TABLE OF CONTENTS

REVISION HISTORY..... 3

SUMMARY OF TEST RESULT 4

1 GENERAL DESCRIPTION 5

 1.1 Applicant..... 5

 1.2 Manufacturer 5

 1.3 Product Feature of Equipment Under Test 5

 1.4 Modification of EUT 6

 1.5 Maximum ERP/EIRP Power, Frequency Tolerance, and Emission Designator 6

 1.6 Testing Location 6

 1.7 Applicable Standards 7

2 TEST CONFIGURATION OF EQUIPMENT UNDER TEST 8

 2.1 Test Mode..... 8

 2.2 Connection Diagram of Test System 9

 2.3 Support Unit used in test configuration 10

 2.4 Measurement Results Explanation Example 10

3 CONDUCTED TEST RESULT..... 11

 3.1 Measuring Instruments..... 11

 3.2 Test Setup 11

 3.3 Test Result of Conducted Test..... 11

 3.4 Conducted Output Power 12

 3.5 Peak-to-Average Ratio 13

 3.6 99% Occupied Bandwidth and 26dB Bandwidth Measurement..... 14

 3.7 Conducted Band Edge 15

 3.8 Conducted Spurious Emission 16

 3.9 Frequency Stability..... 17

4 RADIATED TEST ITEMS 18

 4.1 Measuring Instruments..... 18

 4.2 Test Setup 18

 4.3 Test Result of Radiated Test..... 18

 4.4 Effective Radiated Power and Effective Isotropic Radiated Power Measurement 19

 4.5 Field Strength of Spurious Radiation Measurement 21

5 LIST OF MEASURING EQUIPMENT 22

6 UNCERTAINTY OF EVALUATION 24

APPENDIX A. TEST RESULTS OF CONDUCTED TEST

APPENDIX B. TEST RESULTS OF RADIATED TEST

APPENDIX C. TEST SETUP PHOTOGRAPHS



REVISION HISTORY

REPORT NO.	VERSION	DESCRIPTION	ISSUED DATE
FG571615A	Rev. 01	Initial issue of report	Sep. 14, 2015



SUMMARY OF TEST RESULT

Report Section	FCC Rule	Description	Limit	Result	Remark
3.4	§2.1046	Conducted Output Power	Reporting Only	PASS	-
3.5	§24.232(d)	Peak-to-Average Ratio	< 13 dB	PASS	-
3.6	§2.1049 §22.917(b) §24.238(b)	Occupied Bandwidth	Reporting Only	PASS	-
3.7	§2.1051 §22.917(a) §24.238(a)	Band Edge Measurement	< 43+10log10(P[Watts])	PASS	-
3.8	§2.1051 §22.917(a) §24.238(a)	Conducted Emission	< 43+10log10(P[Watts])	PASS	-
3.9	§2.1055 §22.355	Frequency Stability for Temperature & Voltage	< 2.5 ppm for Part 22	PASS	-
	§2.1055 §24.235		Within Authorized Band		
4.4	§22.913(a)(2)	Effective Radiated Power	< 7 Watts	PASS	-
	§24.232(c)	Equivalent Isotropic Radiated Power	< 2 Watts	PASS	-
4.5	§2.1053 §22.917(a) §24.238(a)	Field Strength of Spurious Radiation	< 43+10log10(P[Watts])	PASS	Under limit 40.04 dB at 7400.000 MHz



1 General Description

1.1 Applicant

Sony Mobile Communications Inc.
Nya Vattentorget, 22188 Lund, Sweden

1.2 Manufacturer

Sony Mobile Communications Inc.
1-8-15 Konan, Minato-ku, Tokyo, 108-0075, Japan

1.3 Product Feature of Equipment Under Test

GSM/WCDMA/LTE, Bluetooth, DTS/UNII a/b/g/n/ac, ANT+, NFC, and GPS

Product Specification subjective to this standard	
Antenna Type	Monopole Antenna

EUT Information List				
IMEI	HW Version	SW Version	S/N	Performed Test Item
004402455334080	A	32.0.D.0.132	BH9001VE2H	Conducted Measurement
004402455336572			BH9001EB2H	Radiated Spurious Emission ERP/EIRP Test

Accessory List	
AC Adapter	Model No. : UCH20
	Type No. : AC-0061-US
	S/N : 5815W22500090 (for Radiated Spurious Emission)
Earphone	Model No. : MDR-NC31E
	Type No. : AG-1110
USB Cable	Model No. : UCB11
	Type No. : AI-0120
	S/N : 1522A733000210 (for Radiated Spurious Emission)

Note:

- Above EUT list and accessory list used are electrically identical per declared by manufacturer.
- Above the accessories list are used to exercise the EUT during test.
- For other wireless features of this EUT, test report will be issued separately.



1.4 Modification of EUT

No modifications are made to the EUT during all test items.

1.5 Maximum ERP/EIRP Power, Frequency Tolerance, and Emission Designator

FCC Rule	System	Type of Modulation	Maximum ERP/EIRP (W)	Frequency Tolerance (ppm)	Emission Designator
Part 22	GSM850 GPRS class 8	GMSK	0.3006	0.0120 ppm	246KGXW
Part 22	GSM850 EDGE class 8	8PSK	0.1143	0.0096 ppm	246KG7W
Part 22	WCDMA Band V RMC 12.2Kbps	QPSK	0.0638	0.0167 ppm	4M15F9W
Part 24	GSM1900 GPRS class 8	GMSK	0.4121	0.0085 ppm	248KGXW
Part 24	GSM1900 EDGE class 8	8PSK	0.2716	0.0096 ppm	248KG7W
Part 24	WCDMA Band II RMC 12.2Kbps	QPSK	0.0883	0.0053 ppm	4M16F9W

1.6 Testing Location

Sporton Lab is accredited to ISO 17025 by Taiwan Accreditation Foundation (TAF code : 1190) and the FCC designation No. TW1022 under the FCC 2.948(e) by Mutual Recognition Agreement (MRA) in FCC Test.

Test Site	SPORTON INTERNATIONAL INC.
Test Site Location	No. 52, Hwa Ya 1 st Rd., Hwa Ya Technology Park, Kwei-Shan District, Tao Yuan City, Taiwan, R.O.C. TEL: +886-3-327-3456 FAX: +886-3-328-4978
Test Site No.	Sporton Site No.
	TH03-HY



Test Site	SPORTON INTERNATIONAL INC.
Test Site Location	No.58, Aly. 75, Ln. 564, Wenhua 3rd Rd., Kwei-Shan District, Tao Yuan City, Taiwan, R.O.C. TEL: +886-3-327-0855
Test Site No.	Sporton Site No.
	03CH11-HY

1.7 Applicable Standards

According to the specifications of the manufacturer, the EUT must comply with the requirements of the following standards:

- ♦ 47 CFR Part 2, 22(H), 24(E)
- ♦ ANSI / TIA / EIA-603-C-2004
- ♦ FCC KDB 971168 D01 Power Meas. License Digital Systems v02r02

Remark: All test items were verified and recorded according to the standards and without any deviation during the test.



2 Test Configuration of Equipment Under Test

2.1 Test Mode

Antenna port conducted and radiated test items were performed according to KDB 971168 D01 Power Meas. License Digital Systems v02r02 with maximum output power.

Radiated measurements were performed with rotating EUT in different three orthogonal test planes to find the maximum emission.

Radiated emissions were investigated as following frequency range:

1. 30 MHz to 9000 MHz for GSM850 and WCDMA Band V.
2. 30 MHz to 19000 MHz for GSM1900 and WCDMA Band II.

All modes and data rates and positions were investigated.

Test modes are chosen to be reported as the worst case configuration below:

Test Modes		
Band	Radiated TCs	Conducted TCs
GSM 850	<ul style="list-style-type: none">■ GPRS class 8 Link■ EDGE class 8 Link	<ul style="list-style-type: none">■ GPRS class 8 Link■ EDGE class 8 Link
GSM 1900	<ul style="list-style-type: none">■ GPRS class 8 Link■ EDGE class 8 Link	<ul style="list-style-type: none">■ GPRS class 8 Link■ EDGE class 8 Link
WCDMA Band V	<ul style="list-style-type: none">■ RMC 12.2Kbps Link	<ul style="list-style-type: none">■ RMC 12.2Kbps Link
WCDMA Band II	<ul style="list-style-type: none">■ RMC 12.2Kbps Link	<ul style="list-style-type: none">■ RMC 12.2Kbps Link

2.2 Connection Diagram of Test System

<EUT with Adapter and Earphone>

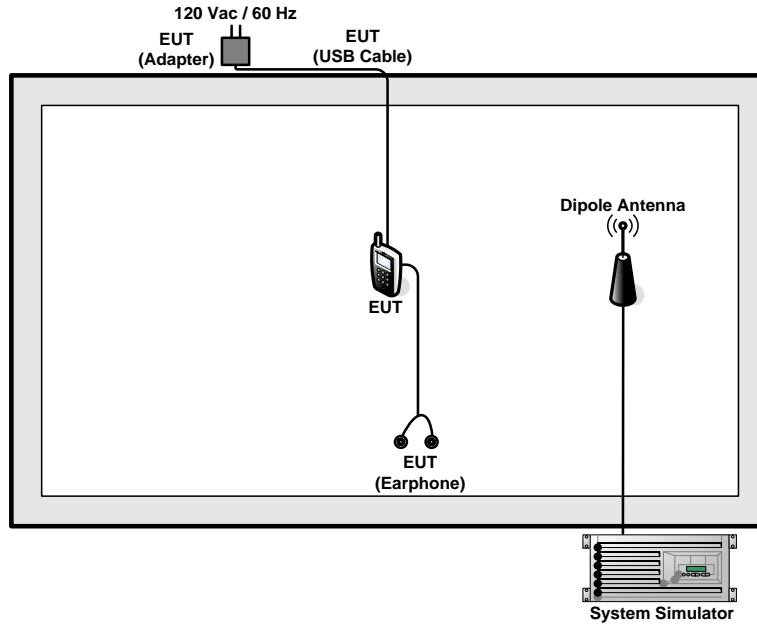

<EUT without Adapter and Earphone>

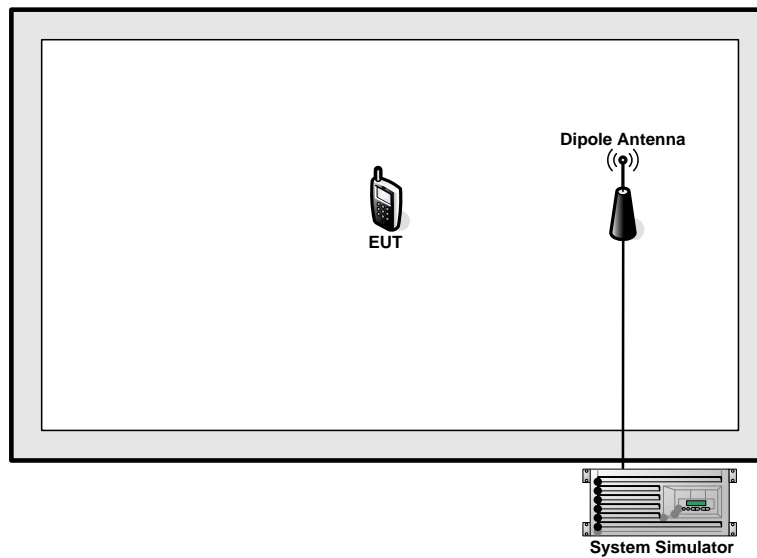



2.3 Support Unit used in test configuration

Item	Equipment	Trade Name	Model No.	FCC ID	Data Cable	Power Cord
1.	System Simulator	R&S	CMU 200	N/A	N/A	Unshielded, 1.8 m

2.4 Measurement Results Explanation Example

For all conducted test items:

The offset level is set in the spectrum analyzer to compensate the RF cable loss and attenuator factor between RF conducted output port and spectrum analyzer. With the offset compensation, the spectrum analyzer reading level will be exactly the RF output level.

The spectrum analyzer offset is derived from RF cable loss and attenuator factor.

$$\text{Offset} = \text{RF cable loss} + \text{attenuator factor}.$$

The following shows an offset computation example with RF cable loss 4.2 dB and a 10dB attenuator.

Example :

$$\begin{aligned} \text{Offset(dB)} &= \text{RF cable loss(dB)} + \text{attenuator factor(dB)}. \\ &= 4.2 + 10 = 14.2 \text{ (dB)} \end{aligned}$$

3 Conducted Test Result

3.1 Measuring Instruments

See list of measuring instruments of this test report.

3.2 Test Setup

3.2.1 Conducted Output Power



3.2.2 Peak-to-Average Ratio, Occupied Bandwidth, Conducted Band-Edge and Conducted Spurious Emission

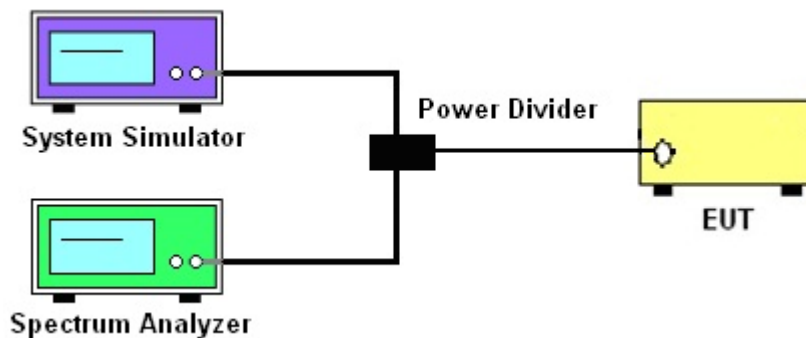

3.2.3 Frequency Stability

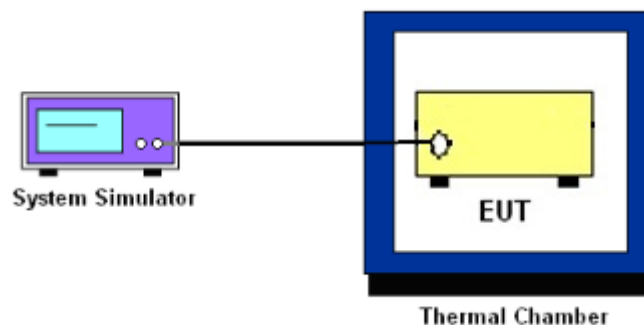

3.3 Test Result of Conducted Test

Please refer to Appendix A.



3.4 Conducted Output Power

3.4.1 Description of the Conducted Output Power

A system simulator was used to establish communication with the EUT. Its parameters were set to enforce EUT transmitting at the maximum power. The measured power in the radio frequency on the transmitter output terminals shall be reported.

3.4.2 Test Procedures

1. The transmitter output port was connected to the system simulator.
2. Set EUT at maximum power through system simulator.
3. Select lowest, middle, and highest channels for each band and different modulation.
4. Measure the maximum burst average power for GSM and maximum average power for other modulation signal.



3.5 Peak-to-Average Ratio

3.5.1 Description of the PAR Measurement

The peak-to-average ratio (PAR) of the transmission may not exceed 13 dB.

3.5.2 Test Procedures

1. The testing follows FCC KDB 971168 D01 v02r02 Section 5.7.1.
2. The EUT was connected to spectrum analyzer and system simulator via a power divider.
3. Set EUT to transmit at maximum output power.
4. When the duty cycle is less than 98%, then signal gating will be implemented on the spectrum analyzer by triggering from the system simulator.
5. Set the CCDF (Complementary Cumulative Distribution Function) option of the spectrum analyzer.
Record the maximum PAPR level associated with a probability of 0.1%.



3.6 99% Occupied Bandwidth and 26dB Bandwidth Measurement

3.6.1 Description of 99% Occupied Bandwidth and 26dB Bandwidth Measurement

The 99% occupied bandwidth is the width of a frequency band such that, below the lower and above the upper frequency limits, the mean powers emitted are each equal to a specified percentage 0.5% of the total mean transmitted power.

The emission bandwidth is defined as the width of the signal between two points, located at the two sides of the carrier frequency, outside of which all emissions are attenuated at least 26 dB below the transmitter power.

3.6.2 Test Procedures

1. The testing follows FCC KDB 971168 D01 v02r02 Section 4.2.
2. The EUT was connected to the spectrum analyzer and system simulator via a power divider.
3. The RF output of the EUT was connected to the spectrum analyzer by RF cable and attenuator. The path loss was compensated to the results for each measurement.
4. The 99% occupied bandwidth were measured, set RBW= 1% of span, VBW= 3*RBW, sample detector, trace maximum hold.
5. The 26dB bandwidth were measured, set RBW= 1% of EBW, VBW= 3*RBW, peak detector, trace maximum hold.



3.7 Conducted Band Edge

3.7.1 Description of Conducted Band Edge Measurement

The power of any emission outside of the authorized operating frequency ranges must be lower than the transmitter power (P) by a factor of at least $43 + 10 \log (P)$ dB.

3.7.2 Test Procedures

1. The testing follows FCC KDB 971168 D01 v02r02 Section 6.0.
2. The EUT was connected to the spectrum analyzer and system simulator via a power divider.
3. The RF output of EUT was connected to the spectrum analyzer by an RF cable and attenuator. The path loss was compensated to the results for each measurement.
4. The band edges of low and high channels for the highest RF powers were measured.
5. The RF fundamental frequency should be excluded against the limit line in the operating frequency band.
6. The limit line is derived from $43 + 10\log(P)$ dB below the transmitter power P(Watts)
= $P(W) - [43 + 10\log(P)]$ (dB)
= $[30 + 10\log(P)]$ (dBm) - $[43 + 10\log(P)]$ (dB)
= -13dBm.



3.8 Conducted Spurious Emission

3.8.1 Description of Conducted Spurious Emission Measurement

The power of any emission outside of the authorized operating frequency ranges must be lower than the transmitter power (P) by a factor of at least $43 + 10 \log (P)$ dB.

It is measured by means of a calibrated spectrum analyzer and scanned from 30 MHz up to a frequency including its 10th harmonic.

3.8.2 Test Procedures

1. The testing follows FCC KDB 971168 D01 v02r02 Section 6.0.
2. The EUT was connected to the spectrum analyzer and system simulator via a power divider.
3. The RF output of EUT was connected to the spectrum analyzer by an RF cable and attenuator. The path loss was compensated to the results for each measurement.
4. The middle channel for the highest RF power within the transmitting frequency was measured.
5. The conducted spurious emission for the whole frequency range was taken.
6. The RF fundamental frequency should be excluded against the limit line in the operating frequency band.
7. The limit line is derived from $43 + 10\log(P)$ dB below the transmitter power P(Watts)
= $P(W) - [43 + 10\log(P)]$ (dB)
= $[30 + 10\log(P)]$ (dBm) - $[43 + 10\log(P)]$ (dB)
= -13dBm.



3.9 Frequency Stability

3.9.1 Description of Frequency Stability Measurement

The frequency stability shall be measured by variation of ambient temperature and variation of primary supply voltage to ensure that the fundamental emission stays within the authorized frequency block. The frequency stability of the transmitter shall be maintained within $\pm 0.00025\%$ ($\pm 2.5\text{ppm}$) of the center frequency.

3.9.2 Test Procedures for Temperature Variation

1. The testing follows FCC KDB 971168 D01 v02r02 Section 9.0.
2. The EUT was set up in the thermal chamber and connected with the system simulator.
3. With power OFF, the temperature was decreased to -30°C and the EUT was stabilized before testing. Power was applied and the maximum change in frequency was recorded within one minute.
4. With power OFF, the temperature was raised in 10°C steps up to 50°C . The EUT was stabilized at each step for at least half an hour. Power was applied and the maximum frequency change was recorded within one minute.

3.9.3 Test Procedures for Voltage Variation

1. The testing follows FCC KDB 971168 D01 v02r02 Section 9.0.
2. The EUT was placed in a temperature chamber at $25\pm 5^{\circ}\text{C}$ and connected with the system simulator.
3. The power supply voltage to the EUT was varied from 85% to 115% of the nominal value measured at the input to the EUT.
4. The variation in frequency was measured for the worst case.

4 Radiated Test Items

4.1 Measuring Instruments

See list of measuring instruments of this test report.

4.2 Test Setup

4.2.1 For radiated test from 30MHz to 1GHz

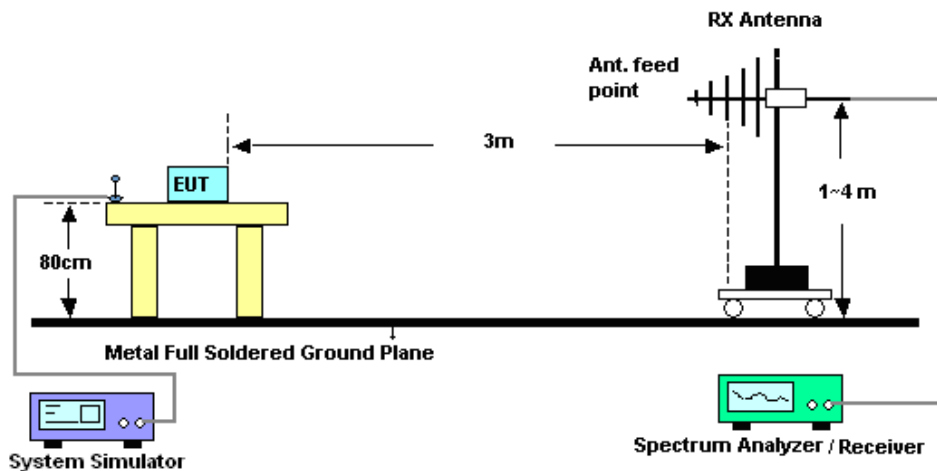

4.2.2 For radiated test above 1GHz

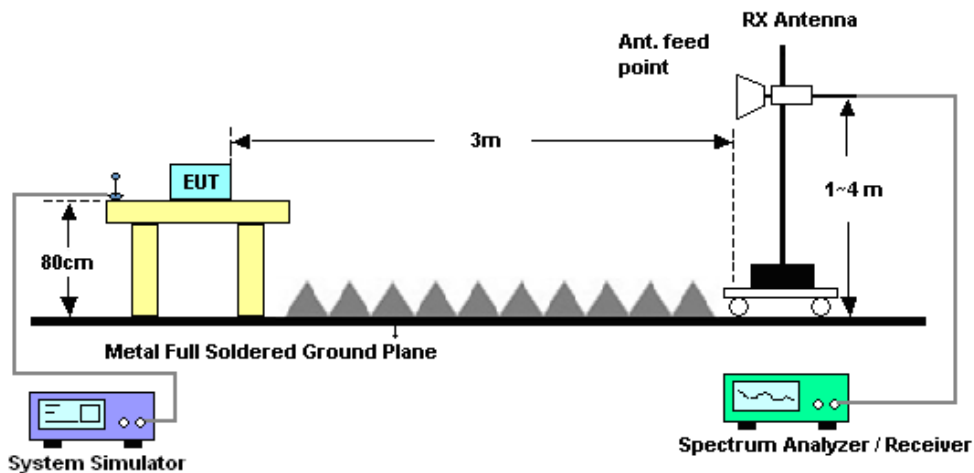

4.3 Test Result of Radiated Test

Please refer to Appendix B.



4.4 Effective Radiated Power and Effective Isotropic Radiated Power Measurement

4.4.1 Description of the ERP/EIRP Measurement

The substitution method, in ANSI / TIA / EIA-603-C-2004, was used for ERP/EIRP measurement, and the spectrum analyzer configuration follows KDB 971168 D01 Power Meas. License Digital Systems v02r02. The ERP of mobile transmitters must not exceed 7 Watts (Cellular Band) and the EIRP of mobile transmitters are limited to 2 Watts (PCS Band)..

4.4.2 Test Procedures

1. The testing follows FCC KDB 971168 D01 v02r02 Section 5.2.1. (for CDMA/WCDMA), Section 5.2.2.2 (for GSM/GPRS/EDGE) and ANSI / TIA-603-C-2004 Section 2.2.17.
2. The EUT was placed on a non-conductive rotating platform 0.8 meters high in a semi-anechoic chamber. The radiated emission at the fundamental frequency was measured at 3 m with a test antenna and a spectrum analyzer with RMS detector per section 5. of KDB 971168 D01.
3. During the measurement, the system simulator parameters were set to force the EUT transmitting at maximum output power. The maximum emission was recorded from analyzer power level (LVL) from the 360 degrees rotation of the turntable and the test antenna raised and lowered over a range from 1 to 4 meters in both horizontally and vertically polarized orientations.
4. Effective Isotropic Radiated Power (EIRP) was measured by substitution method according to TIA/EIA-603-C. The EUT was replaced by the substitution antenna at same location, and then a known power from S.G. was applied into the dipole antenna through a Tx cable, and then recorded the maximum Analyzer reading through raised and lowered the test antenna. The correction factor (in dB) = S.G. - Tx Cable loss + Substitution antenna gain - Analyzer reading. Then the EUT's EIRP was calculated with the correction factor, $EIRP = LVL + \text{Correction factor}$ and $ERP = EIRP - 2.15$. Take the record of the output power at substitution antenna.



	GSM/GPRS/EDGE	WCDMA/HSPA
SPAN	500kHz	10MHz
RBW	10kHz	100kHz
VBW	30kHz	300kHz
Detector	RMS	RMS
Trace	Average	Average
Average Type	Power	Power
Sweep Count	100	100



4.5 Field Strength of Spurious Radiation Measurement

4.5.1 Description of Field Strength of Spurious Radiated Measurement

The power of any emission outside of the authorized operating frequency ranges must be attenuated below the transmitter power (P) by a factor of at least $43 + 10 \log (P)$ dB. The spectrum is scanned from 30 MHz up to a frequency including its 10th harmonic.

4.5.2 Test Procedures

1. The testing follows FCC KDB 971168 D01 v02r02 Section 5.8 and ANSI / TIA-603-C-2004 Section 2.2.12.
2. The EUT was placed on a rotatable wooden table 0.8 meters above the ground.
3. The EUT was set 3 meters from the receiving antenna, which was mounted on the antenna tower.
4. The table was rotated 360 degrees to determine the position of the highest spurious emission.
5. The height of the receiving antenna is varied between one meter and four meters to search for the maximum spurious emission for both horizontal and vertical polarizations.
6. Make the measurement with the spectrum analyzer's RBW = 1MHz, VBW = 3MHz, taking record of maximum spurious emission.
7. A horn antenna was substituted in place of the EUT and was driven by a signal generator.
8. Tune the output power of signal generator to the same emission level with EUT maximum spurious emission.
9. Taking the record of output power at antenna port.
10. Repeat step 7 to step 8 for another polarization.
11. $EIRP \text{ (dBm)} = S.G. \text{ Power} - Tx \text{ Cable Loss} + Tx \text{ Antenna Gain}$
12. $ERP \text{ (dBm)} = EIRP - 2.15$
13. The RF fundamental frequency should be excluded against the limit line in the operating frequency band.
14. The limit line is derived from $43 + 10\log(P)$ dB below the transmitter power P(Watts)
 $= P(W) - [43 + 10\log(P)] \text{ (dB)}$
 $= [30 + 10\log(P)] \text{ (dBm)} - [43 + 10\log(P)] \text{ (dB)}$
 $= -13dBm.$



5 List of Measuring Equipment

Instrument	Manufacturer	Model No.	Serial No.	Characteristics	Calibration Date	Test Date	Due Date	Remark
Spectrum Analyzer	Rohde & Schwarz	FSP30	101329	9kHz~30GHz	Jun. 24, 2015	Aug. 13, 2015	Jun. 23, 2016	Conducted (TH03-HY)
Base Station (Measure)	Rohde & Schwarz	CMU200	117995	GSM / GPRS / WCDMA / CDMA	Jul. 26, 2015	Aug. 13, 2015	Jul. 25, 2016	Conducted (TH03-HY)
Hygrometer	Testo	608-H1	34893241	N/A	May 04, 2015	Aug. 13, 2015	May 03, 2016	Conducted (TH03-HY)
Temperature Chamber	ESPEC	SU-641	92013721	-30~70	Dec. 01, 2014	Aug. 13, 2015	Nov. 30, 2015	Conducted (TH03-HY)
RF cable	WOKEN	S05	S05-130708-22	N/A	Jan. 21, 2015	Aug. 13, 2015	Jan. 20, 2016	Conducted (TH03-HY)
Horn Antenna	SCHWARZBECK	BBHA 9170	BBHA9170584	18GHz- 40GHz	Nov. 03, 2014	Aug. 19, 2015~ Aug. 25, 2015	Nov. 02, 2015	Radiation (03CH11-HY)
Preamplifier	MITEQ	JS44-18004000-33-8P	1840917	18GHz ~ 40GHz	Jun. 02, 2015	Aug. 19, 2015~ Aug. 25, 2015	Jun. 01, 2016	Radiation (03CH11-HY)
Amplifier	SONOMA	310N	187312	9kHz~1GHz	Nov. 24, 2014	Aug. 19, 2015~ Aug. 25, 2015	Nov. 23, 2015	Radiation (03CH11-HY)
Bilog Antenna	TESEQ	CBL 6111D	35414	30MHz~1GHz	Oct. 24, 2014	Aug. 19, 2015~ Aug. 25, 2015	Oct. 23, 2015	Radiation (03CH11-HY)
Horn Antenna	SCHWARZBECK	BBHA 9120D	9120D-1326	1GHz ~ 18GHz	Oct. 03, 2014	Aug. 19, 2015~ Aug. 25, 2015	Oct. 02, 2015	Radiation (03CH11-HY)
Hygrometer	TECPEL	DTN-303B	TP140325	N/A	Nov. 19, 2014	Aug. 19, 2015~ Aug. 25, 2015	Nov. 18, 2015	Radiation (03CH11-HY)
Preamplifier	Keysight	83017A	MY53270080	1GHz~26.5GHz	Nov. 20, 2014	Aug. 19, 2015~ Aug. 25, 2015	Nov. 19, 2015	Radiation (03CH11-HY)
Spectrum Analyzer	Keysight	N9010A	MY54200486	10Hz ~ 44GHZ	Sep. 24, 2014	Aug. 19, 2015~ Aug. 25, 2015	Sep. 23, 2015	Radiation (03CH11-HY)
RF Cable	HUBER + SUHNER	SUCOFLEX 104	MY24967/4 MY28419/4	25GHz~40GHz	Nov. 06, 2014	Aug. 19, 2015~ Aug. 25, 2015	Nov. 05, 2015	Radiation (03CH11-HY)
RF Cable	HUBER + SUHNER	SUCOFLEX 104	MY24967/4 MY28419/4	30MHz~1GHz	Nov. 06, 2014	Aug. 19, 2015~ Aug. 25, 2015	Nov. 05, 2015	Radiation (03CH11-HY)
RF Cable	HUBER + SUHNER	SUCOFLEX 104	MY24967/4 MY28419/4	1GHz~25GHz	Nov. 06, 2014	Aug. 19, 2015~ Aug. 25, 2015	Nov. 05, 2015	Radiation (03CH11-HY)
Controller	EMEC	EM 1000	N/A	Control Turn table & Ant Mast	N/A	Aug. 19, 2015~ Aug. 25, 2015	N/A	Radiation (03CH11-HY)
Antenna Mast	EMEC	AM-BS-4500-B	N/A	1~4m	N/A	Aug. 19, 2015~ Aug. 25, 2015	N/A	Radiation (03CH11-HY)
Turn Table	EMEC	TT 2000	N/A	0-360 degree	N/A	Aug. 19, 2015~ Aug. 25, 2015	N/A	Radiation (03CH11-HY)



Instrument	Manufacturer	Model No.	Serial No.	Characteristics	Calibration Date	Test Date	Due Date	Remark
Filter	Wainwright	WLKS1200-8SS	SN3	1.2G Low Pass	Oct. 01, 2014	Aug. 19, 2015~ Aug. 25, 2015	Sep. 30, 2015	Radiation (03CH11-HY)
Filter	Wainwright	WHK1.5/15 G-10SS	SN32	1.5G High Pass	Oct. 01, 2014	Aug. 19, 2015~ Aug. 25, 2015	Sep. 30, 2015	Radiation (03CH11-HY)
Filter	Microwave	H3G018G1	SN477220	3.0G High Pass	Oct. 01, 2014	Aug. 19, 2015~ Aug. 25, 2015	Sep. 30, 2015	Radiation (03CH11-HY)
Notch Filter	Wainwright	WRCG824/8 49-40/8SS	SN35	CDMA 850	Oct. 01, 2014	Aug. 19, 2015~ Aug. 25, 2015	Sep. 30, 2015	Radiation (03CH11-HY)
Test Software	Audix	E3	6.2009-8-24	N/A	N/A	Aug. 19, 2015~ Aug. 25, 2015	N/A	Radiation (03CH11-HY)



6 Uncertainty of Evaluation

Uncertainty of Radiated Emission Measurement (30 MHz ~ 1000 MHz)

Measuring Uncertainty for a Level of Confidence of 95% ($U = 2Uc(y)$)	4.90
---	------



Appendix A. Test Results of Conducted Test

Conducted Output Power(Average power)

Conducted Power (*Unit: dBm)						
Band	GSM850			GSM1900		
Channel	128	189	251	512	661	810
Frequency	824.2	836.4	848.8	1850.2	1880.0	1909.8
GSM	31.40	31.52	31.63	27.93	27.95	28.03
GPRS class 8	31.43	31.54	31.66	27.99	27.99	28.07
GPRS class 10	30.16	30.27	30.40	25.40	25.30	25.35
GPRS class 11	28.70	28.75	28.86	23.22	23.26	23.24
GPRS class 12	27.46	27.58	27.65	21.77	21.70	21.81
EGPRS class 8	27.27	27.36	27.40	26.30	26.26	26.33
EGPRS class 10	26.03	26.13	26.18	25.11	25.07	25.15
EGPRS class 11	24.19	24.27	24.31	23.08	23.04	23.09
EGPRS class 12	23.08	23.16	23.22	20.75	20.73	20.80

Conducted Power (*Unit: dBm)						
Band	WCDMA Band V			WCDMA Band II		
Channel	4132	4182	4233	9262	9400	9538
Frequency	826.4	836.4	846.6	1852.4	1880	1907.6
RMC 12.2K	24.05	24.11	23.98	20.71	20.77	20.83
HSDPA Subtest-1	23.04	23.11	22.97	19.72	19.77	19.90
HSDPA Subtest-2	23.08	23.12	22.99	19.71	19.78	19.86
HSDPA Subtest-3	22.54	22.62	22.47	19.20	19.21	19.35
HSDPA Subtest-4	22.64	22.58	22.46	19.17	19.25	19.33
HSUPA Subtest-1	21.52	21.56	21.50	19.08	19.02	19.10
HSUPA Subtest-2	21.94	21.97	21.76	18.60	18.62	18.71
HSUPA Subtest-3	21.95	21.99	21.96	18.30	18.35	18.41
HSUPA Subtest-4	22.17	22.19	22.36	18.79	18.75	18.82
HSUPA Subtest-5	23.14	23.21	22.96	19.71	19.77	19.84



A1. GSM

Peak-to-Average Ratio

Mode	GSM850		Limit: 13dB
Mod.	GPRS class 8	EDGE class 8	Result
Lowest CH	0.24	3.56	PASS
Middle CH	0.20	3.12	
Highest CH	0.24	3.24	

Mode	GSM1900		Limit: 13dB
Mod.	GPRS class 8	EDGE class 8	Result
Lowest CH	0.28	3.20	PASS
Middle CH	0.28	3.04	
Highest CH	0.24	3.08	

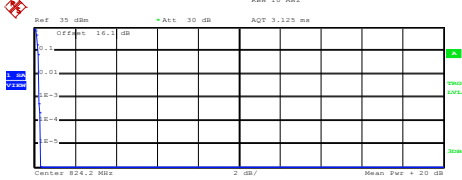
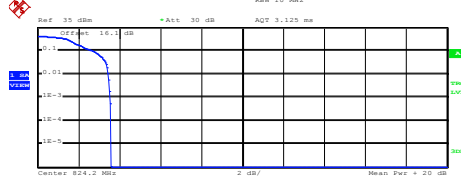
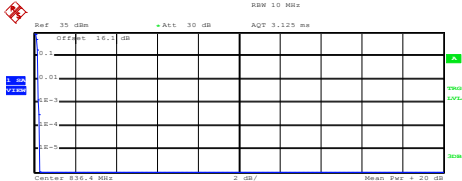
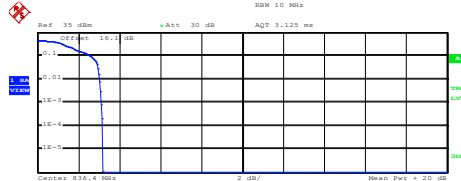
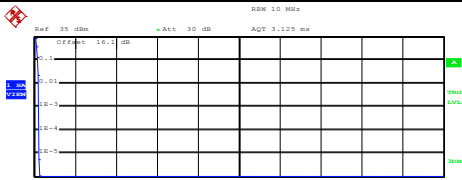
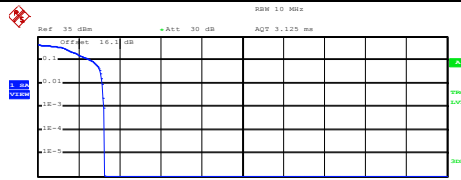

GSM850 (GPRS class 8)	GSM850 (EDGE class 8)
<p align="center">Lowest Channel</p>  <p>Ref: 35 dBm *Att: 30 dB AQT: 3.125 ms</p> <p>Center: 824.2 MHz 2 dB/ Mean Pwr: +20 dB</p> <p>Complementary Cumulative Distribution Function (100000 samples)</p> <p>Trace 1</p> <p>Mean: 30.43 dBm Peak: 30.74 dBm Crest: 0.31 dB</p> <p>10 %: 0.20 dB 1 %: 0.24 dB .1 %: 0.24 dB .01 %: 0.32 dB</p> <p>Date: 13.AUG.2015 10:16:25</p>	<p align="center">Lowest Channel</p>  <p>Ref: 35 dBm *Att: 30 dB AQT: 3.125 ms</p> <p>Center: 824.2 MHz 2 dB/ Mean Pwr: +20 dB</p> <p>Complementary Cumulative Distribution Function (100000 samples)</p> <p>Trace 1</p> <p>Mean: 25.47 dBm Peak: 29.04 dBm Crest: 3.57 dB</p> <p>10 %: 2.72 dB 1 %: 3.44 dB .1 %: 3.56 dB .01 %: 3.60 dB</p> <p>Date: 13.AUG.2015 10:25:09</p>
<p align="center">Middle Channel</p>  <p>Ref: 35 dBm *Att: 30 dB AQT: 3.125 ms</p> <p>Center: 836.4 MHz 2 dB/ Mean Pwr: +20 dB</p> <p>Complementary Cumulative Distribution Function (100000 samples)</p> <p>Trace 1</p> <p>Mean: 30.70 dBm Peak: 30.95 dBm Crest: 0.25 dB</p> <p>10 %: 0.16 dB 1 %: 0.20 dB .1 %: 0.20 dB .01 %: 0.28 dB</p> <p>Date: 13.AUG.2015 10:16:36</p>	<p align="center">Middle Channel</p>  <p>Ref: 35 dBm *Att: 30 dB AQT: 3.125 ms</p> <p>Center: 836.4 MHz 2 dB/ Mean Pwr: +20 dB</p> <p>Complementary Cumulative Distribution Function (100000 samples)</p> <p>Trace 1</p> <p>Mean: 26.35 dBm Peak: 29.54 dBm Crest: 3.19 dB</p> <p>10 %: 2.60 dB 1 %: 3.04 dB .1 %: 3.12 dB .01 %: 3.20 dB</p> <p>Date: 13.AUG.2015 10:25:20</p>
<p align="center">Highest Channel</p>  <p>Ref: 35 dBm *Att: 30 dB AQT: 3.125 ms</p> <p>Center: 848.8 MHz 2 dB/ Mean Pwr: +20 dB</p> <p>Complementary Cumulative Distribution Function (100000 samples)</p> <p>Trace 1</p> <p>Mean: 30.18 dBm Peak: 30.46 dBm Crest: 0.28 dB</p> <p>10 %: 0.16 dB 1 %: 0.24 dB .1 %: 0.24 dB .01 %: 0.24 dB</p> <p>Date: 13.AUG.2015 10:16:49</p>	<p align="center">Highest Channel</p>  <p>Ref: 35 dBm *Att: 30 dB AQT: 3.125 ms</p> <p>Center: 848.8 MHz 2 dB/ Mean Pwr: +20 dB</p> <p>Complementary Cumulative Distribution Function (100000 samples)</p> <p>Trace 1</p> <p>Mean: 26.28 dBm Peak: 29.54 dBm Crest: 3.26 dB</p> <p>10 %: 2.60 dB 1 %: 3.16 dB .1 %: 3.24 dB .01 %: 3.28 dB</p> <p>Date: 13.AUG.2015 10:25:32</p>

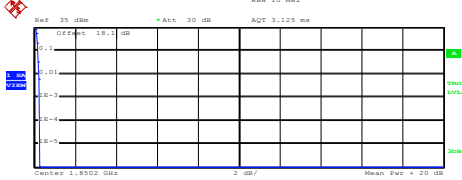
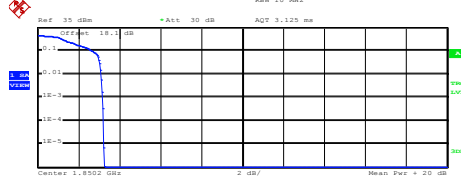
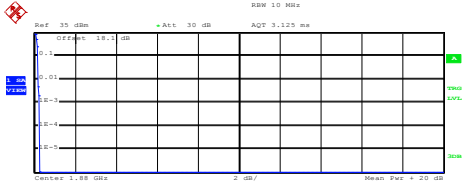
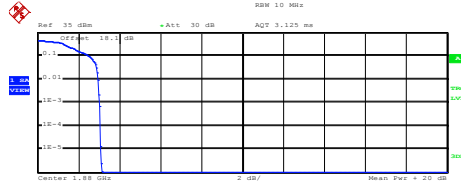
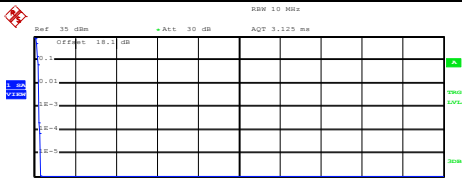
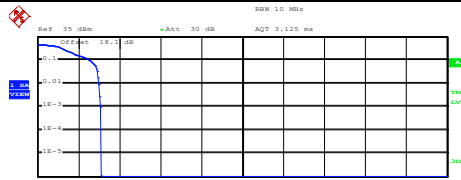

GSM1900 (GPRS class 8)	GSM1900 (EDGE class 8)																
<p align="center">Lowest Channel</p>  <p>Complementary Cumulative Distribution Function (100000 samples) Trace 1 Mean 25.69 dBm Peak 25.94 dBm Crest 0.25 dB</p> <table border="1"> <tr><td>10 %</td><td>0.20 dB</td></tr> <tr><td>1 %</td><td>0.24 dB</td></tr> <tr><td>.1 %</td><td>0.28 dB</td></tr> <tr><td>.01 %</td><td>0.28 dB</td></tr> </table> <p>Date: 13.AUG.2015 10:35:41</p>	10 %	0.20 dB	1 %	0.24 dB	.1 %	0.28 dB	.01 %	0.28 dB	<p align="center">Lowest Channel</p>  <p>Complementary Cumulative Distribution Function (100000 samples) Trace 1 Mean 25.32 dBm Peak 28.55 dBm Crest 3.23 dB</p> <table border="1"> <tr><td>10 %</td><td>2.68 dB</td></tr> <tr><td>1 %</td><td>3.12 dB</td></tr> <tr><td>.1 %</td><td>3.20 dB</td></tr> <tr><td>.01 %</td><td>3.24 dB</td></tr> </table> <p>Date: 13.AUG.2015 10:44:55</p>	10 %	2.68 dB	1 %	3.12 dB	.1 %	3.20 dB	.01 %	3.24 dB
10 %	0.20 dB																
1 %	0.24 dB																
.1 %	0.28 dB																
.01 %	0.28 dB																
10 %	2.68 dB																
1 %	3.12 dB																
.1 %	3.20 dB																
.01 %	3.24 dB																
<p align="center">Middle Channel</p>  <p>Complementary Cumulative Distribution Function (100000 samples) Trace 1 Mean 25.53 dBm Peak 25.80 dBm Crest 0.27 dB</p> <table border="1"> <tr><td>10 %</td><td>0.20 dB</td></tr> <tr><td>1 %</td><td>0.20 dB</td></tr> <tr><td>.1 %</td><td>0.28 dB</td></tr> <tr><td>.01 %</td><td>0.28 dB</td></tr> </table> <p>Date: 13.AUG.2015 10:35:52</p>	10 %	0.20 dB	1 %	0.20 dB	.1 %	0.28 dB	.01 %	0.28 dB	<p align="center">Middle Channel</p>  <p>Complementary Cumulative Distribution Function (100000 samples) Trace 1 Mean 25.08 dBm Peak 28.20 dBm Crest 3.12 dB</p> <table border="1"> <tr><td>10 %</td><td>2.52 dB</td></tr> <tr><td>1 %</td><td>2.96 dB</td></tr> <tr><td>.1 %</td><td>3.04 dB</td></tr> <tr><td>.01 %</td><td>3.08 dB</td></tr> </table> <p>Date: 13.AUG.2015 10:45:07</p>	10 %	2.52 dB	1 %	2.96 dB	.1 %	3.04 dB	.01 %	3.08 dB
10 %	0.20 dB																
1 %	0.20 dB																
.1 %	0.28 dB																
.01 %	0.28 dB																
10 %	2.52 dB																
1 %	2.96 dB																
.1 %	3.04 dB																
.01 %	3.08 dB																
<p align="center">Highest Channel</p>  <p>Complementary Cumulative Distribution Function (100000 samples) Trace 1 Mean 25.50 dBm Peak 25.80 dBm Crest 0.30 dB</p> <table border="1"> <tr><td>10 %</td><td>0.20 dB</td></tr> <tr><td>1 %</td><td>0.24 dB</td></tr> <tr><td>.1 %</td><td>0.24 dB</td></tr> <tr><td>.01 %</td><td>0.28 dB</td></tr> </table> <p>Date: 13.AUG.2015 10:36:04</p>	10 %	0.20 dB	1 %	0.24 dB	.1 %	0.24 dB	.01 %	0.28 dB	<p align="center">Highest Channel</p>  <p>Complementary Cumulative Distribution Function (100000 samples) Trace 1 Mean 25.23 dBm Peak 28.34 dBm Crest 3.11 dB</p> <table border="1"> <tr><td>10 %</td><td>2.56 dB</td></tr> <tr><td>1 %</td><td>3.00 dB</td></tr> <tr><td>.1 %</td><td>3.08 dB</td></tr> <tr><td>.01 %</td><td>3.12 dB</td></tr> </table> <p>Date: 13.AUG.2015 10:45:21</p>	10 %	2.56 dB	1 %	3.00 dB	.1 %	3.08 dB	.01 %	3.12 dB
10 %	0.20 dB																
1 %	0.24 dB																
.1 %	0.24 dB																
.01 %	0.28 dB																
10 %	2.56 dB																
1 %	3.00 dB																
.1 %	3.08 dB																
.01 %	3.12 dB																



26dB Bandwidth

Mode	GSM850	
Mod.	GPRS class 8	EDGE class 8
Lowest CH	0.311	0.309
Middle CH	0.311	0.299
Highest CH	0.310	0.310

Mode	GSM1900	
Mod.	GPRS class 8	EDGE class 8
Lowest CH	0.317	0.302
Middle CH	0.316	0.309
Highest CH	0.311	0.303

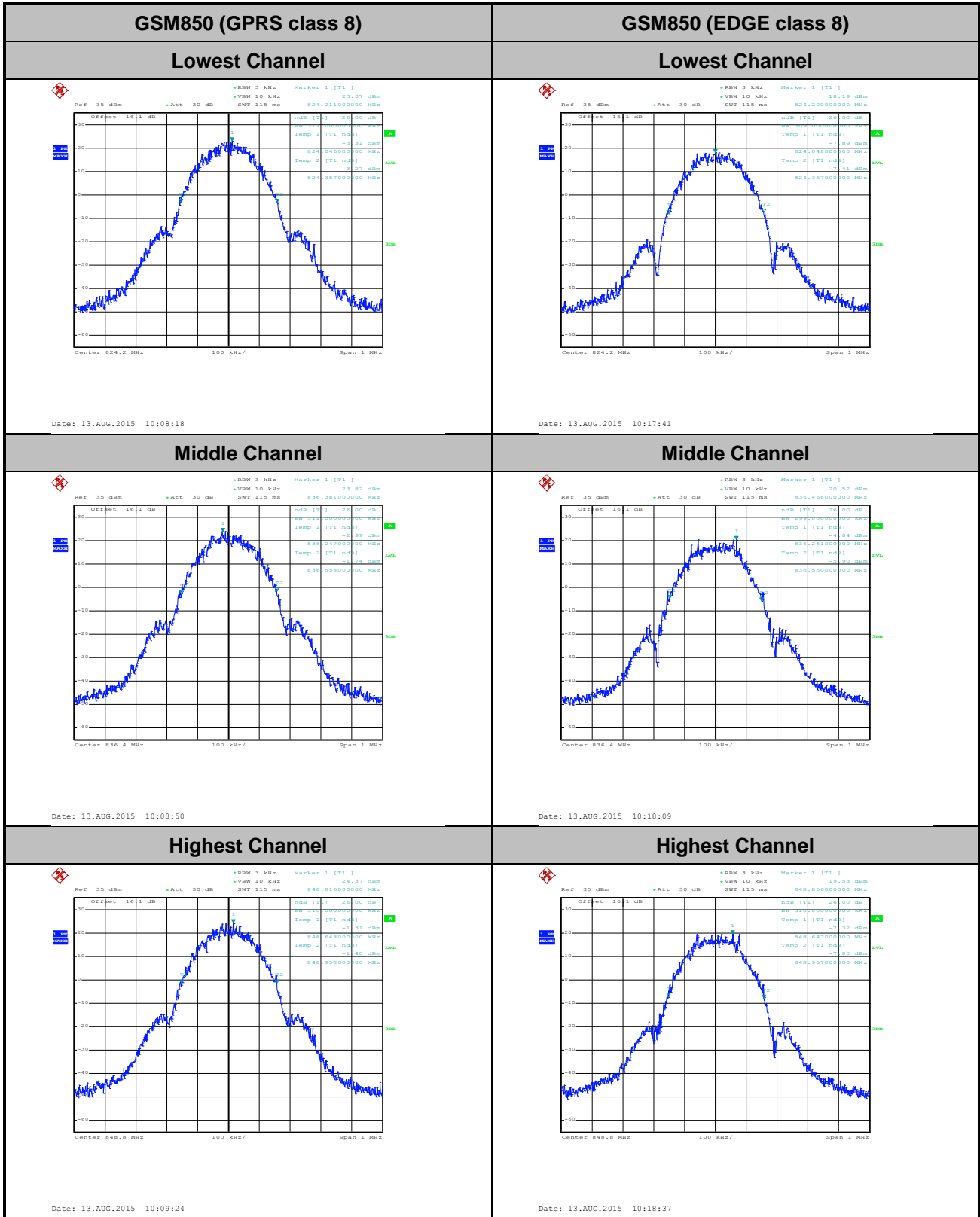

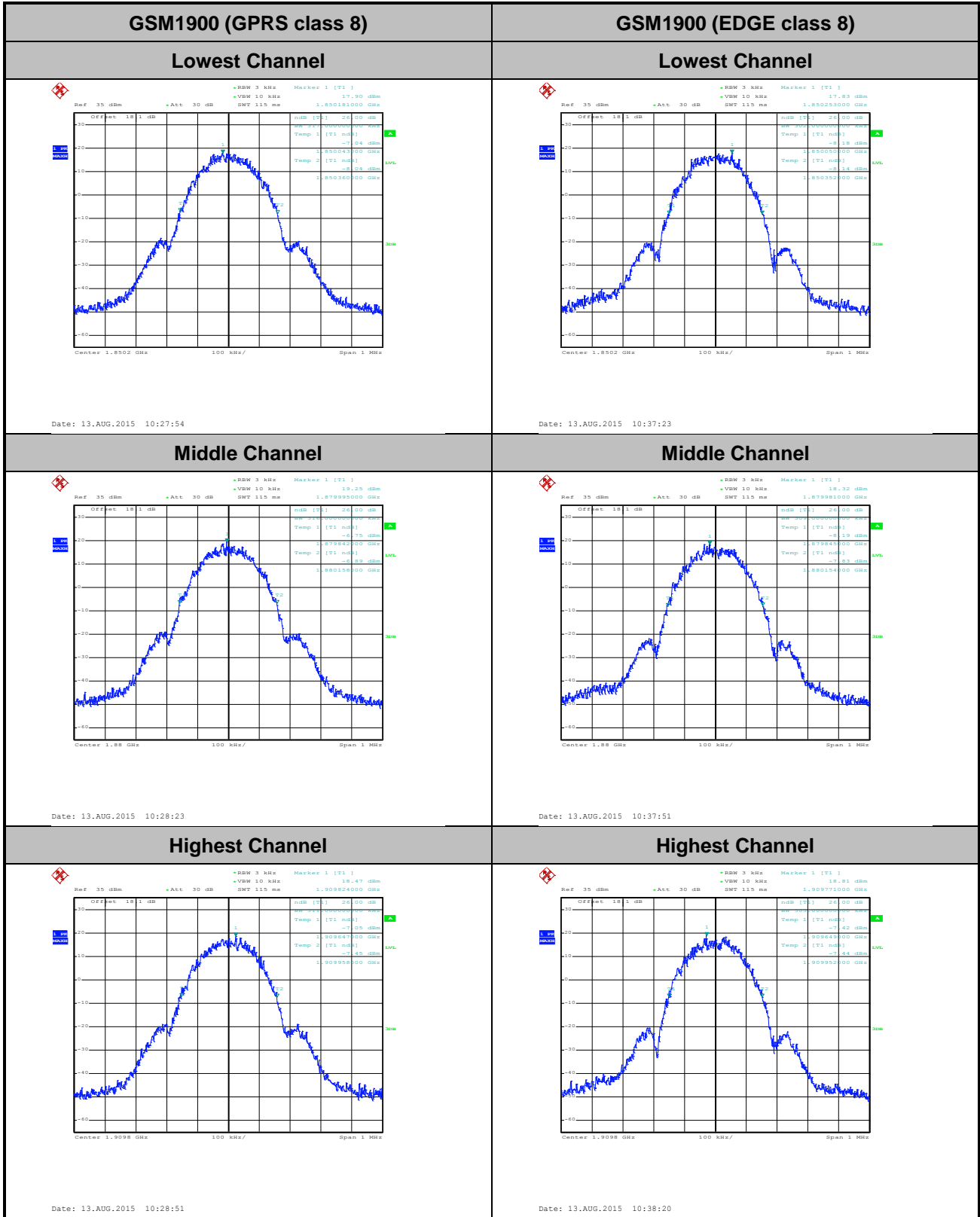



Occupied Bandwidth

Mode	GSM850	
Mod.	GPRS class 8	EDGE class 8
Lowest CH	0.245	0.241
Middle CH	0.246	0.245
Highest CH	0.244	0.246

Mode	GSM1900	
Mod.	GPRS class 8	EDGE class 8
Lowest CH	0.243	0.245
Middle CH	0.243	0.246
Highest CH	0.248	0.248

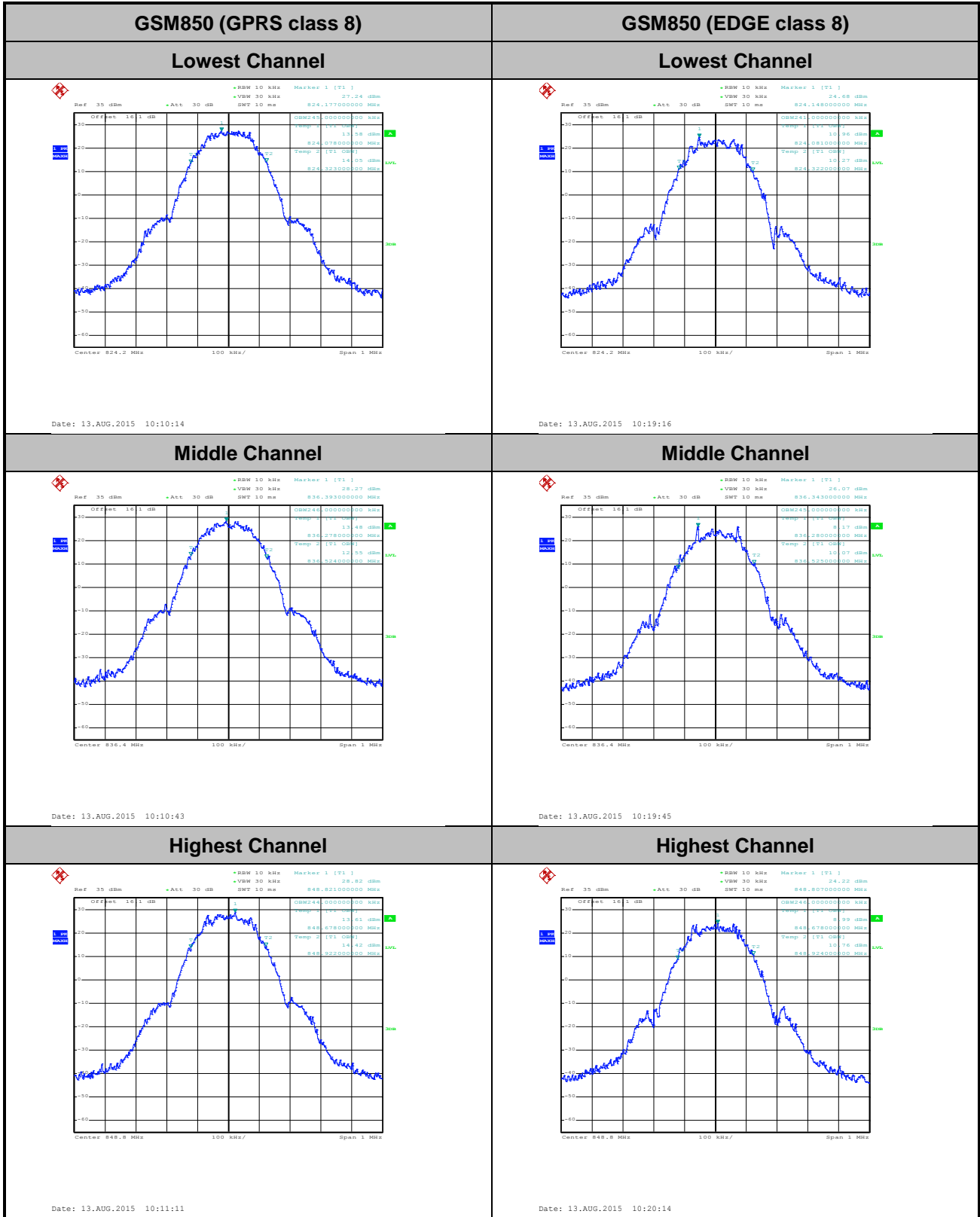

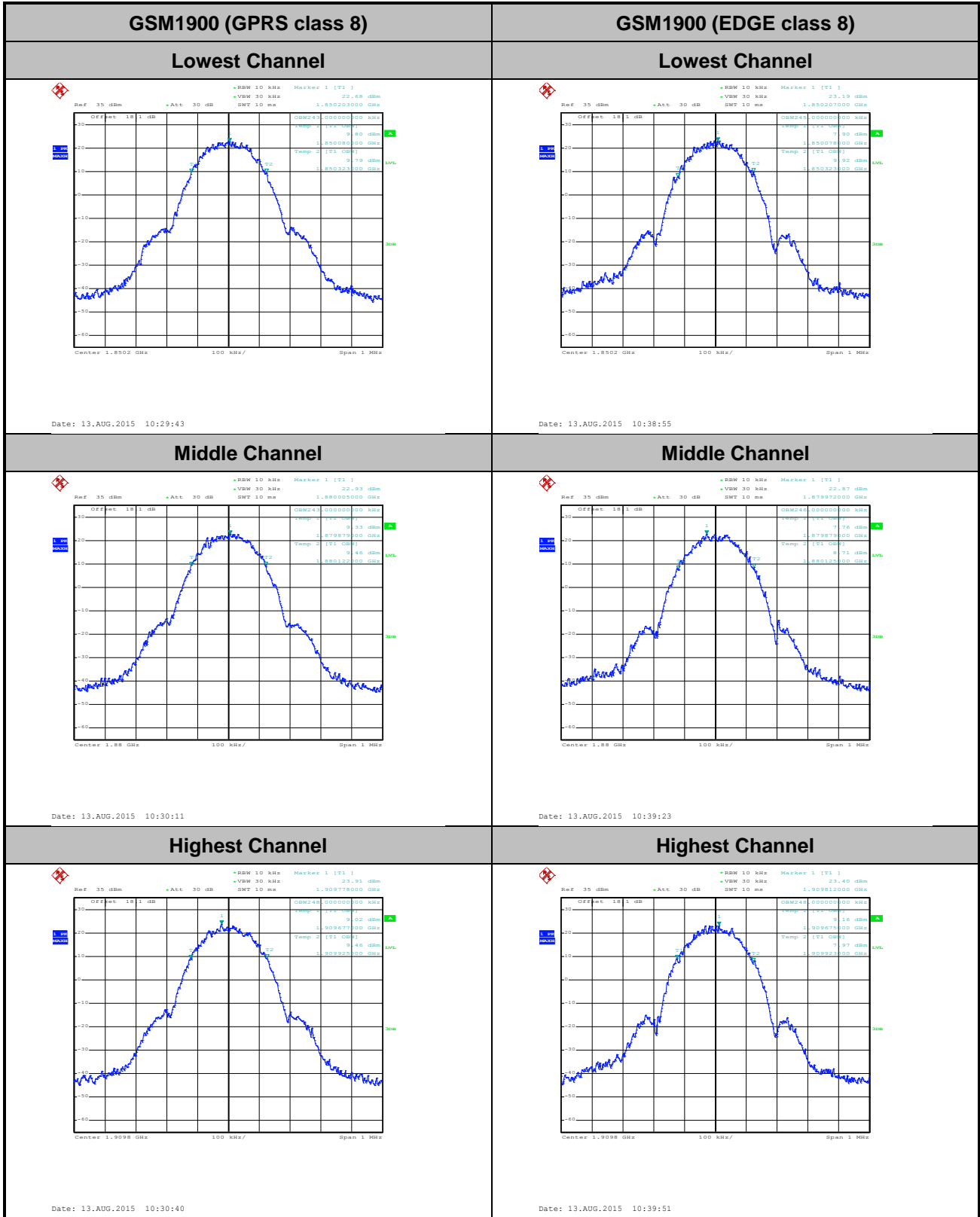



Conducted Band Edge



GSM850 (GPRS class 8)

Lowest Band Edge

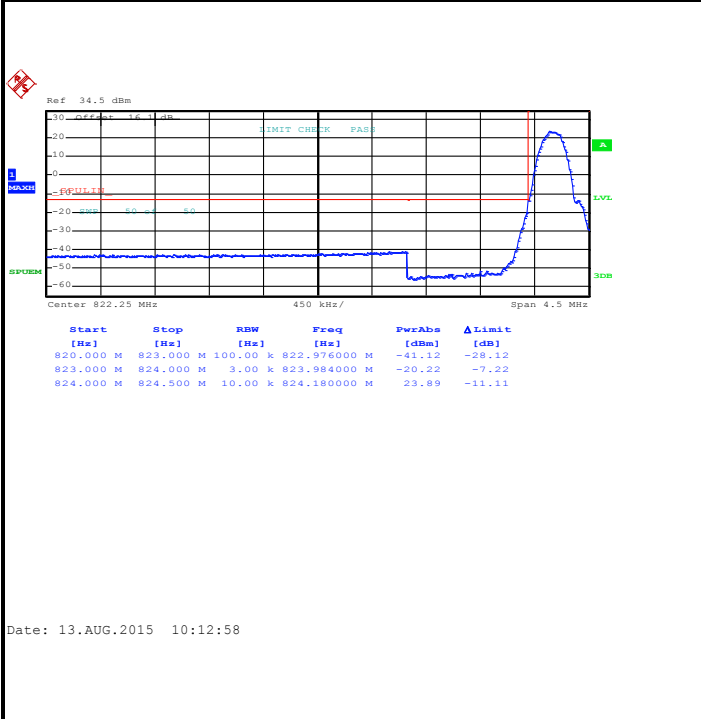

Highest Band Edge

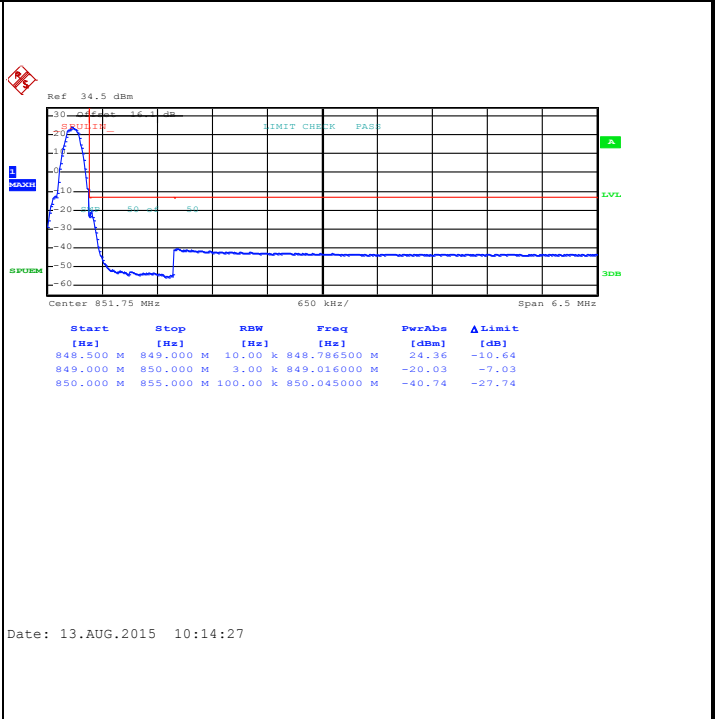

GSM850 (EDGE class 8)

Lowest Band Edge

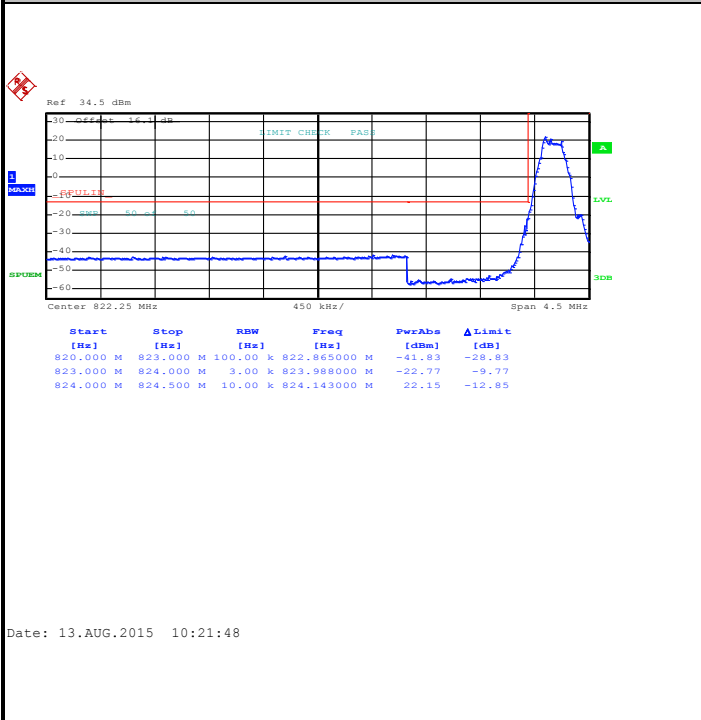

Highest Band Edge

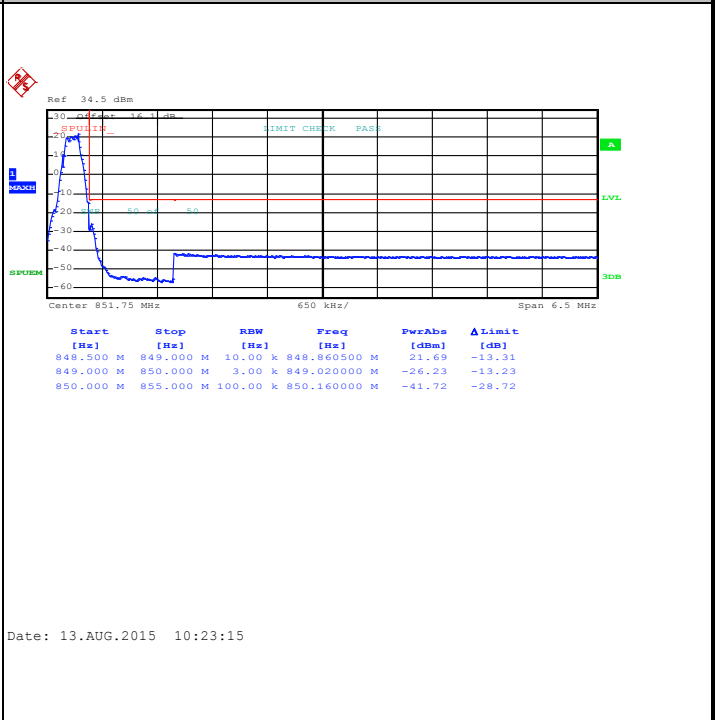



GSM1900 (GPRS class 8)

Lowest Band Edge

Highest Band Edge

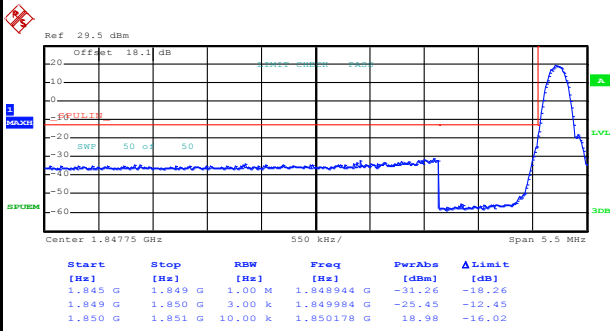

Date: 13.AUG.2015 10:32:20

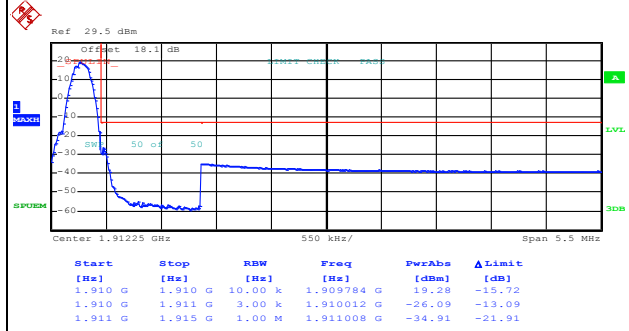

Date: 13.AUG.2015 10:33:48

GSM1900 (EDGE class 8)

Lowest Band Edge

Highest Band Edge

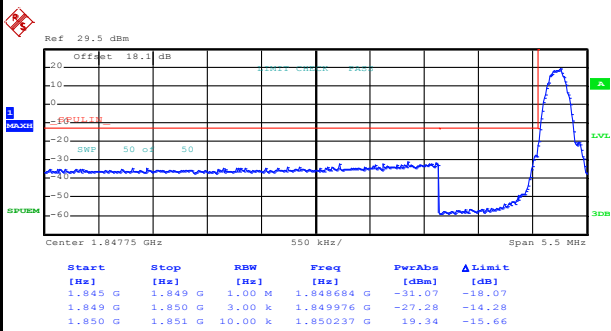

Date: 13.AUG.2015 10:41:25

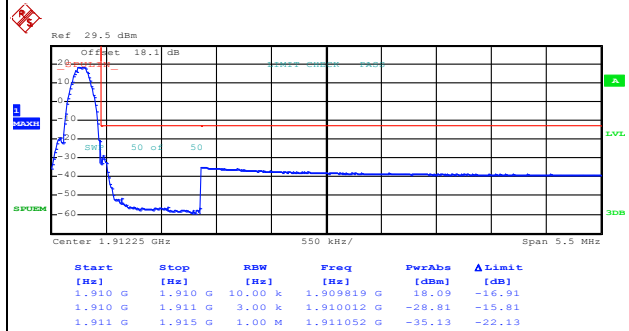

Date: 13.AUG.2015 10:42:53



Conducted Spurious Emission

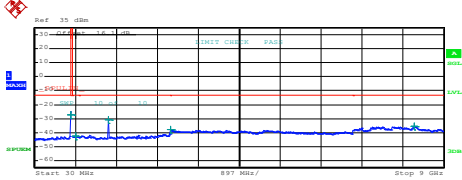
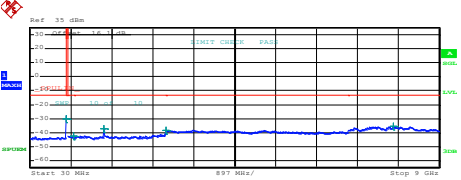
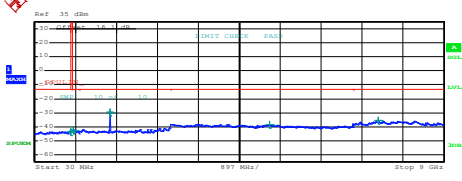
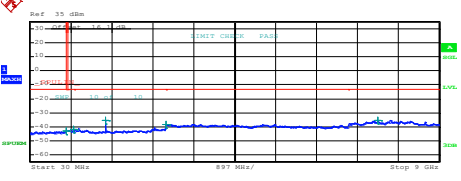
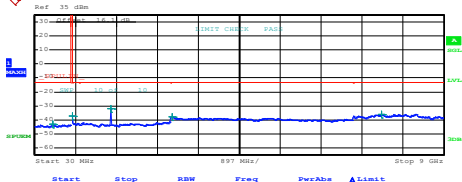
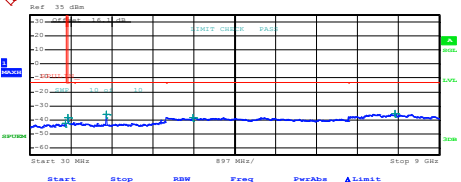

GSM850 (GPRS class 8)	GSM850 (EDGE class 8)																																																																								
Lowest Channel	Lowest Channel																																																																								
 <table border="1" data-bbox="239 577 638 660"> <thead> <tr> <th>Start [Hz]</th> <th>Stop [Hz]</th> <th>RBW [Hz]</th> <th>Freq [Hz]</th> <th>PwrAve [dBm]</th> <th>ΔLimit [dB]</th> </tr> </thead> <tbody> <tr> <td>35,000 M</td> <td>825,000 M</td> <td>1,00 M</td> <td>819,802500 M</td> <td>-27.45</td> <td>-14.45</td> </tr> <tr> <td>855,000 M</td> <td>1,000 G</td> <td>1,00 M</td> <td>923,331255 M</td> <td>-42.61</td> <td>-29.61</td> </tr> <tr> <td>1,000 G</td> <td>3,000 G</td> <td>1,00 M</td> <td>1,6488500 G</td> <td>-30.62</td> <td>-27.62</td> </tr> <tr> <td>3,000 G</td> <td>7,000 G</td> <td>1,00 M</td> <td>3,0070000 G</td> <td>-38.09</td> <td>-25.09</td> </tr> <tr> <td>7,000 G</td> <td>9,000 G</td> <td>1,00 M</td> <td>8,3580000 G</td> <td>-35.62</td> <td>-22.62</td> </tr> </tbody> </table> <p>Date: 13.AUG.2015 10:15:03</p>	Start [Hz]	Stop [Hz]	RBW [Hz]	Freq [Hz]	PwrAve [dBm]	ΔLimit [dB]	35,000 M	825,000 M	1,00 M	819,802500 M	-27.45	-14.45	855,000 M	1,000 G	1,00 M	923,331255 M	-42.61	-29.61	1,000 G	3,000 G	1,00 M	1,6488500 G	-30.62	-27.62	3,000 G	7,000 G	1,00 M	3,0070000 G	-38.09	-25.09	7,000 G	9,000 G	1,00 M	8,3580000 G	-35.62	-22.62	 <table border="1" data-bbox="893 577 1292 660"> <thead> <tr> <th>Start [Hz]</th> <th>Stop [Hz]</th> <th>RBW [Hz]</th> <th>Freq [Hz]</th> <th>PwrAve [dBm]</th> <th>ΔLimit [dB]</th> </tr> </thead> <tbody> <tr> <td>35,000 M</td> <td>825,000 M</td> <td>1,00 M</td> <td>819,802500 M</td> <td>-30.49</td> <td>-17.49</td> </tr> <tr> <td>855,000 M</td> <td>1,000 G</td> <td>1,00 M</td> <td>976,582508 M</td> <td>-42.42</td> <td>-29.42</td> </tr> <tr> <td>1,000 G</td> <td>3,000 G</td> <td>1,00 M</td> <td>1,6488500 G</td> <td>-37.53</td> <td>-24.53</td> </tr> <tr> <td>3,000 G</td> <td>7,000 G</td> <td>1,00 M</td> <td>3,0000000 G</td> <td>-38.15</td> <td>-25.15</td> </tr> <tr> <td>7,000 G</td> <td>9,000 G</td> <td>1,00 M</td> <td>8,0010000 G</td> <td>-35.71</td> <td>-22.71</td> </tr> </tbody> </table> <p>Date: 13.AUG.2015 10:23:53</p>	Start [Hz]	Stop [Hz]	RBW [Hz]	Freq [Hz]	PwrAve [dBm]	ΔLimit [dB]	35,000 M	825,000 M	1,00 M	819,802500 M	-30.49	-17.49	855,000 M	1,000 G	1,00 M	976,582508 M	-42.42	-29.42	1,000 G	3,000 G	1,00 M	1,6488500 G	-37.53	-24.53	3,000 G	7,000 G	1,00 M	3,0000000 G	-38.15	-25.15	7,000 G	9,000 G	1,00 M	8,0010000 G	-35.71	-22.71
Start [Hz]	Stop [Hz]	RBW [Hz]	Freq [Hz]	PwrAve [dBm]	ΔLimit [dB]																																																																				
35,000 M	825,000 M	1,00 M	819,802500 M	-27.45	-14.45																																																																				
855,000 M	1,000 G	1,00 M	923,331255 M	-42.61	-29.61																																																																				
1,000 G	3,000 G	1,00 M	1,6488500 G	-30.62	-27.62																																																																				
3,000 G	7,000 G	1,00 M	3,0070000 G	-38.09	-25.09																																																																				
7,000 G	9,000 G	1,00 M	8,3580000 G	-35.62	-22.62																																																																				
Start [Hz]	Stop [Hz]	RBW [Hz]	Freq [Hz]	PwrAve [dBm]	ΔLimit [dB]																																																																				
35,000 M	825,000 M	1,00 M	819,802500 M	-30.49	-17.49																																																																				
855,000 M	1,000 G	1,00 M	976,582508 M	-42.42	-29.42																																																																				
1,000 G	3,000 G	1,00 M	1,6488500 G	-37.53	-24.53																																																																				
3,000 G	7,000 G	1,00 M	3,0000000 G	-38.15	-25.15																																																																				
7,000 G	9,000 G	1,00 M	8,0010000 G	-35.71	-22.71																																																																				
Middle Channel	Middle Channel																																																																								
 <table border="1" data-bbox="239 1104 638 1187"> <thead> <tr> <th>Start [Hz]</th> <th>Stop [Hz]</th> <th>RBW [Hz]</th> <th>Freq [Hz]</th> <th>PwrAve [dBm]</th> <th>ΔLimit [dB]</th> </tr> </thead> <tbody> <tr> <td>35,000 M</td> <td>825,000 M</td> <td>1,00 M</td> <td>818,222500 M</td> <td>-43.41</td> <td>-30.41</td> </tr> <tr> <td>855,000 M</td> <td>1,000 G</td> <td>1,00 M</td> <td>869,137501 M</td> <td>-42.24</td> <td>-29.24</td> </tr> <tr> <td>1,000 G</td> <td>3,000 G</td> <td>1,00 M</td> <td>1,6730000 G</td> <td>-29.81</td> <td>-16.81</td> </tr> <tr> <td>3,000 G</td> <td>7,000 G</td> <td>1,00 M</td> <td>3,1850000 G</td> <td>-38.31</td> <td>-25.31</td> </tr> <tr> <td>7,000 G</td> <td>9,000 G</td> <td>1,00 M</td> <td>7,3690000 G</td> <td>-35.69</td> <td>-22.69</td> </tr> </tbody> </table> <p>Date: 13.AUG.2015 10:15:34</p>	Start [Hz]	Stop [Hz]	RBW [Hz]	Freq [Hz]	PwrAve [dBm]	ΔLimit [dB]	35,000 M	825,000 M	1,00 M	818,222500 M	-43.41	-30.41	855,000 M	1,000 G	1,00 M	869,137501 M	-42.24	-29.24	1,000 G	3,000 G	1,00 M	1,6730000 G	-29.81	-16.81	3,000 G	7,000 G	1,00 M	3,1850000 G	-38.31	-25.31	7,000 G	9,000 G	1,00 M	7,3690000 G	-35.69	-22.69	 <table border="1" data-bbox="893 1104 1292 1187"> <thead> <tr> <th>Start [Hz]</th> <th>Stop [Hz]</th> <th>RBW [Hz]</th> <th>Freq [Hz]</th> <th>PwrAve [dBm]</th> <th>ΔLimit [dB]</th> </tr> </thead> <tbody> <tr> <td>35,000 M</td> <td>825,000 M</td> <td>1,00 M</td> <td>817,037500 M</td> <td>-43.23</td> <td>-30.23</td> </tr> <tr> <td>855,000 M</td> <td>1,000 G</td> <td>1,00 M</td> <td>881,931259 M</td> <td>-42.33</td> <td>-29.33</td> </tr> <tr> <td>1,000 G</td> <td>3,000 G</td> <td>1,00 M</td> <td>1,6725000 G</td> <td>-35.40</td> <td>-22.40</td> </tr> <tr> <td>3,000 G</td> <td>7,000 G</td> <td>1,00 M</td> <td>3,0030000 G</td> <td>-38.33</td> <td>-25.33</td> </tr> <tr> <td>7,000 G</td> <td>9,000 G</td> <td>1,00 M</td> <td>7,4530000 G</td> <td>-35.72</td> <td>-22.72</td> </tr> </tbody> </table> <p>Date: 13.AUG.2015 10:24:24</p>	Start [Hz]	Stop [Hz]	RBW [Hz]	Freq [Hz]	PwrAve [dBm]	ΔLimit [dB]	35,000 M	825,000 M	1,00 M	817,037500 M	-43.23	-30.23	855,000 M	1,000 G	1,00 M	881,931259 M	-42.33	-29.33	1,000 G	3,000 G	1,00 M	1,6725000 G	-35.40	-22.40	3,000 G	7,000 G	1,00 M	3,0030000 G	-38.33	-25.33	7,000 G	9,000 G	1,00 M	7,4530000 G	-35.72	-22.72
Start [Hz]	Stop [Hz]	RBW [Hz]	Freq [Hz]	PwrAve [dBm]	ΔLimit [dB]																																																																				
35,000 M	825,000 M	1,00 M	818,222500 M	-43.41	-30.41																																																																				
855,000 M	1,000 G	1,00 M	869,137501 M	-42.24	-29.24																																																																				
1,000 G	3,000 G	1,00 M	1,6730000 G	-29.81	-16.81																																																																				
3,000 G	7,000 G	1,00 M	3,1850000 G	-38.31	-25.31																																																																				
7,000 G	9,000 G	1,00 M	7,3690000 G	-35.69	-22.69																																																																				
Start [Hz]	Stop [Hz]	RBW [Hz]	Freq [Hz]	PwrAve [dBm]	ΔLimit [dB]																																																																				
35,000 M	825,000 M	1,00 M	817,037500 M	-43.23	-30.23																																																																				
855,000 M	1,000 G	1,00 M	881,931259 M	-42.33	-29.33																																																																				
1,000 G	3,000 G	1,00 M	1,6725000 G	-35.40	-22.40																																																																				
3,000 G	7,000 G	1,00 M	3,0030000 G	-38.33	-25.33																																																																				
7,000 G	9,000 G	1,00 M	7,4530000 G	-35.72	-22.72																																																																				
Highest Channel	Highest Channel																																																																								
 <table border="1" data-bbox="239 1630 638 1713"> <thead> <tr> <th>Start [Hz]</th> <th>Stop [Hz]</th> <th>RBW [Hz]</th> <th>Freq [Hz]</th> <th>PwrAve [dBm]</th> <th>ΔLimit [dB]</th> </tr> </thead> <tbody> <tr> <td>35,000 M</td> <td>825,000 M</td> <td>1,00 M</td> <td>431,235000 M</td> <td>-43.25</td> <td>-30.25</td> </tr> <tr> <td>855,000 M</td> <td>1,000 G</td> <td>1,00 M</td> <td>850,072500 M</td> <td>-37.01</td> <td>-24.01</td> </tr> <tr> <td>1,000 G</td> <td>3,000 G</td> <td>1,00 M</td> <td>1,6975000 G</td> <td>-32.07</td> <td>-19.07</td> </tr> <tr> <td>3,000 G</td> <td>7,000 G</td> <td>1,00 M</td> <td>3,0500000 G</td> <td>-37.86</td> <td>-24.86</td> </tr> <tr> <td>7,000 G</td> <td>9,000 G</td> <td>1,00 M</td> <td>7,6290000 G</td> <td>-35.83</td> <td>-22.83</td> </tr> </tbody> </table> <p>Date: 13.AUG.2015 10:16:04</p>	Start [Hz]	Stop [Hz]	RBW [Hz]	Freq [Hz]	PwrAve [dBm]	ΔLimit [dB]	35,000 M	825,000 M	1,00 M	431,235000 M	-43.25	-30.25	855,000 M	1,000 G	1,00 M	850,072500 M	-37.01	-24.01	1,000 G	3,000 G	1,00 M	1,6975000 G	-32.07	-19.07	3,000 G	7,000 G	1,00 M	3,0500000 G	-37.86	-24.86	7,000 G	9,000 G	1,00 M	7,6290000 G	-35.83	-22.83	 <table border="1" data-bbox="893 1630 1292 1713"> <thead> <tr> <th>Start [Hz]</th> <th>Stop [Hz]</th> <th>RBW [Hz]</th> <th>Freq [Hz]</th> <th>PwrAve [dBm]</th> <th>ΔLimit [dB]</th> </tr> </thead> <tbody> <tr> <td>35,000 M</td> <td>825,000 M</td> <td>1,00 M</td> <td>801,231500 M</td> <td>-42.51</td> <td>-29.51</td> </tr> <tr> <td>855,000 M</td> <td>1,000 G</td> <td>1,00 M</td> <td>850,108750 M</td> <td>-38.46</td> <td>-25.46</td> </tr> <tr> <td>1,000 G</td> <td>3,000 G</td> <td>1,00 M</td> <td>1,6975000 G</td> <td>-35.77</td> <td>-22.77</td> </tr> <tr> <td>3,000 G</td> <td>7,000 G</td> <td>1,00 M</td> <td>3,0090000 G</td> <td>-38.21</td> <td>-25.21</td> </tr> <tr> <td>7,000 G</td> <td>9,000 G</td> <td>1,00 M</td> <td>8,0315000 G</td> <td>-35.43</td> <td>-22.43</td> </tr> </tbody> </table> <p>Date: 13.AUG.2015 10:24:54</p>	Start [Hz]	Stop [Hz]	RBW [Hz]	Freq [Hz]	PwrAve [dBm]	ΔLimit [dB]	35,000 M	825,000 M	1,00 M	801,231500 M	-42.51	-29.51	855,000 M	1,000 G	1,00 M	850,108750 M	-38.46	-25.46	1,000 G	3,000 G	1,00 M	1,6975000 G	-35.77	-22.77	3,000 G	7,000 G	1,00 M	3,0090000 G	-38.21	-25.21	7,000 G	9,000 G	1,00 M	8,0315000 G	-35.43	-22.43
Start [Hz]	Stop [Hz]	RBW [Hz]	Freq [Hz]	PwrAve [dBm]	ΔLimit [dB]																																																																				
35,000 M	825,000 M	1,00 M	431,235000 M	-43.25	-30.25																																																																				
855,000 M	1,000 G	1,00 M	850,072500 M	-37.01	-24.01																																																																				
1,000 G	3,000 G	1,00 M	1,6975000 G	-32.07	-19.07																																																																				
3,000 G	7,000 G	1,00 M	3,0500000 G	-37.86	-24.86																																																																				
7,000 G	9,000 G	1,00 M	7,6290000 G	-35.83	-22.83																																																																				
Start [Hz]	Stop [Hz]	RBW [Hz]	Freq [Hz]	PwrAve [dBm]	ΔLimit [dB]																																																																				
35,000 M	825,000 M	1,00 M	801,231500 M	-42.51	-29.51																																																																				
855,000 M	1,000 G	1,00 M	850,108750 M	-38.46	-25.46																																																																				
1,000 G	3,000 G	1,00 M	1,6975000 G	-35.77	-22.77																																																																				
3,000 G	7,000 G	1,00 M	3,0090000 G	-38.21	-25.21																																																																				
7,000 G	9,000 G	1,00 M	8,0315000 G	-35.43	-22.43																																																																				

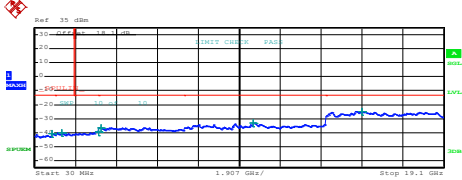
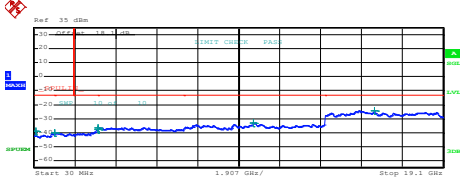
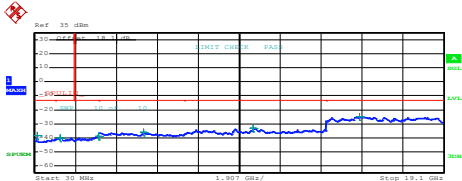
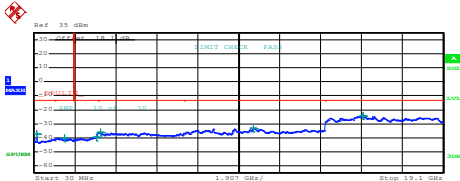
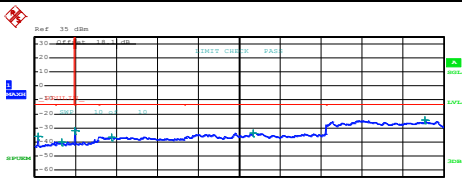
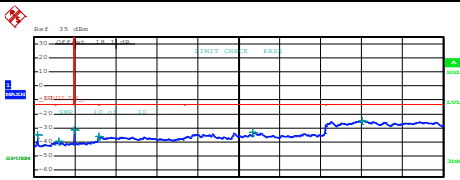

GSM1900 (GPRS class 8)	GSM1900 (EDGE class 8)																																																																																				
Lowest Channel	Lowest Channel																																																																																				
 <table border="1" data-bbox="239 571 638 672"> <thead> <tr> <th>Start [Hz]</th> <th>Stop [Hz]</th> <th>RBW [Hz]</th> <th>Freq [Hz]</th> <th>PwrAve [dBm]</th> <th>ΔLimit [dB]</th> </tr> </thead> <tbody> <tr><td>30.000 M</td><td>1.000 G</td><td>1.00 M</td><td>843.102500 M</td><td>-40.77</td><td>-27.73</td></tr> <tr><td>1.000 G</td><td>1.845 G</td><td>1.00 M</td><td>1.287089 G</td><td>-39.94</td><td>-26.94</td></tr> <tr><td>1.845 G</td><td>3.000 G</td><td>1.00 M</td><td>2.090235 G</td><td>-39.47</td><td>-26.47</td></tr> <tr><td>3.000 G</td><td>7.000 G</td><td>1.00 M</td><td>3.102000 G</td><td>-36.49</td><td>-23.49</td></tr> <tr><td>7.000 G</td><td>13.600 G</td><td>1.00 M</td><td>10.215025 G</td><td>-33.08</td><td>-20.08</td></tr> <tr><td>13.600 G</td><td>19.100 G</td><td>1.00 M</td><td>15.300388 G</td><td>-24.96</td><td>-11.96</td></tr> </tbody> </table> <p>Date: 13.AUG.2015 10:34:24</p>	Start [Hz]	Stop [Hz]	RBW [Hz]	Freq [Hz]	PwrAve [dBm]	ΔLimit [dB]	30.000 M	1.000 G	1.00 M	843.102500 M	-40.77	-27.73	1.000 G	1.845 G	1.00 M	1.287089 G	-39.94	-26.94	1.845 G	3.000 G	1.00 M	2.090235 G	-39.47	-26.47	3.000 G	7.000 G	1.00 M	3.102000 G	-36.49	-23.49	7.000 G	13.600 G	1.00 M	10.215025 G	-33.08	-20.08	13.600 G	19.100 G	1.00 M	15.300388 G	-24.96	-11.96	 <table border="1" data-bbox="888 571 1287 672"> <thead> <tr> <th>Start [Hz]</th> <th>Stop [Hz]</th> <th>RBW [Hz]</th> <th>Freq [Hz]</th> <th>PwrAve [dBm]</th> <th>ΔLimit [dB]</th> </tr> </thead> <tbody> <tr><td>30.000 M</td><td>1.000 G</td><td>1.00 M</td><td>111.722500 M</td><td>-39.92</td><td>-25.92</td></tr> <tr><td>1.000 G</td><td>1.845 G</td><td>1.00 M</td><td>1.001036 G</td><td>-40.33</td><td>-27.33</td></tr> <tr><td>1.845 G</td><td>3.000 G</td><td>1.00 M</td><td>2.999965 G</td><td>-37.82</td><td>-24.82</td></tr> <tr><td>3.000 G</td><td>7.000 G</td><td>1.00 M</td><td>3.014000 G</td><td>-36.41</td><td>-23.41</td></tr> <tr><td>7.000 G</td><td>13.600 G</td><td>1.00 M</td><td>10.226275 G</td><td>-33.33</td><td>-20.33</td></tr> <tr><td>13.600 G</td><td>19.100 G</td><td>1.00 M</td><td>15.304875 G</td><td>-24.51</td><td>-11.51</td></tr> </tbody> </table> <p>Date: 13.AUG.2015 10:43:32</p>	Start [Hz]	Stop [Hz]	RBW [Hz]	Freq [Hz]	PwrAve [dBm]	ΔLimit [dB]	30.000 M	1.000 G	1.00 M	111.722500 M	-39.92	-25.92	1.000 G	1.845 G	1.00 M	1.001036 G	-40.33	-27.33	1.845 G	3.000 G	1.00 M	2.999965 G	-37.82	-24.82	3.000 G	7.000 G	1.00 M	3.014000 G	-36.41	-23.41	7.000 G	13.600 G	1.00 M	10.226275 G	-33.33	-20.33	13.600 G	19.100 G	1.00 M	15.304875 G	-24.51	-11.51
Start [Hz]	Stop [Hz]	RBW [Hz]	Freq [Hz]	PwrAve [dBm]	ΔLimit [dB]																																																																																
30.000 M	1.000 G	1.00 M	843.102500 M	-40.77	-27.73																																																																																
1.000 G	1.845 G	1.00 M	1.287089 G	-39.94	-26.94																																																																																
1.845 G	3.000 G	1.00 M	2.090235 G	-39.47	-26.47																																																																																
3.000 G	7.000 G	1.00 M	3.102000 G	-36.49	-23.49																																																																																
7.000 G	13.600 G	1.00 M	10.215025 G	-33.08	-20.08																																																																																
13.600 G	19.100 G	1.00 M	15.300388 G	-24.96	-11.96																																																																																
Start [Hz]	Stop [Hz]	RBW [Hz]	Freq [Hz]	PwrAve [dBm]	ΔLimit [dB]																																																																																
30.000 M	1.000 G	1.00 M	111.722500 M	-39.92	-25.92																																																																																
1.000 G	1.845 G	1.00 M	1.001036 G	-40.33	-27.33																																																																																
1.845 G	3.000 G	1.00 M	2.999965 G	-37.82	-24.82																																																																																
3.000 G	7.000 G	1.00 M	3.014000 G	-36.41	-23.41																																																																																
7.000 G	13.600 G	1.00 M	10.226275 G	-33.33	-20.33																																																																																
13.600 G	19.100 G	1.00 M	15.304875 G	-24.51	-11.51																																																																																
Middle Channel	Middle Channel																																																																																				
 <table border="1" data-bbox="239 1086 638 1187"> <thead> <tr> <th>Start [Hz]</th> <th>Stop [Hz]</th> <th>RBW [Hz]</th> <th>Freq [Hz]</th> <th>PwrAve [dBm]</th> <th>ΔLimit [dB]</th> </tr> </thead> <tbody> <tr><td>30.000 M</td><td>1.000 G</td><td>1.00 M</td><td>141.792500 M</td><td>-38.52</td><td>-25.52</td></tr> <tr><td>1.000 G</td><td>1.845 G</td><td>1.00 M</td><td>1.233886 G</td><td>-39.93</td><td>-26.93</td></tr> <tr><td>1.845 G</td><td>3.000 G</td><td>1.00 M</td><td>2.995660 G</td><td>-39.08</td><td>-26.08</td></tr> <tr><td>3.000 G</td><td>7.000 G</td><td>1.00 M</td><td>3.115000 G</td><td>-36.31</td><td>-23.31</td></tr> <tr><td>7.000 G</td><td>13.600 G</td><td>1.00 M</td><td>10.216975 G</td><td>-33.07</td><td>-20.07</td></tr> <tr><td>13.600 G</td><td>19.100 G</td><td>1.00 M</td><td>15.160825 G</td><td>-24.94</td><td>-11.94</td></tr> </tbody> </table> <p>Date: 13.AUG.2015 10:34:54</p>	Start [Hz]	Stop [Hz]	RBW [Hz]	Freq [Hz]	PwrAve [dBm]	ΔLimit [dB]	30.000 M	1.000 G	1.00 M	141.792500 M	-38.52	-25.52	1.000 G	1.845 G	1.00 M	1.233886 G	-39.93	-26.93	1.845 G	3.000 G	1.00 M	2.995660 G	-39.08	-26.08	3.000 G	7.000 G	1.00 M	3.115000 G	-36.31	-23.31	7.000 G	13.600 G	1.00 M	10.216975 G	-33.07	-20.07	13.600 G	19.100 G	1.00 M	15.160825 G	-24.94	-11.94	 <table border="1" data-bbox="888 1086 1287 1187"> <thead> <tr> <th>Start [Hz]</th> <th>Stop [Hz]</th> <th>RBW [Hz]</th> <th>Freq [Hz]</th> <th>PwrAve [dBm]</th> <th>ΔLimit [dB]</th> </tr> </thead> <tbody> <tr><td>30.000 M</td><td>1.000 G</td><td>1.00 M</td><td>141.792500 M</td><td>-37.39</td><td>-24.39</td></tr> <tr><td>1.000 G</td><td>1.845 G</td><td>1.00 M</td><td>1.452289 G</td><td>-40.36</td><td>-27.36</td></tr> <tr><td>1.845 G</td><td>3.000 G</td><td>1.00 M</td><td>2.912677 G</td><td>-39.43</td><td>-26.43</td></tr> <tr><td>3.000 G</td><td>7.000 G</td><td>1.00 M</td><td>3.102000 G</td><td>-36.29</td><td>-23.29</td></tr> <tr><td>7.000 G</td><td>13.600 G</td><td>1.00 M</td><td>10.233600 G</td><td>-33.14</td><td>-20.14</td></tr> <tr><td>13.600 G</td><td>19.100 G</td><td>1.00 M</td><td>15.344875 G</td><td>-24.50</td><td>-11.50</td></tr> </tbody> </table> <p>Date: 13.AUG.2015 10:44:03</p>	Start [Hz]	Stop [Hz]	RBW [Hz]	Freq [Hz]	PwrAve [dBm]	ΔLimit [dB]	30.000 M	1.000 G	1.00 M	141.792500 M	-37.39	-24.39	1.000 G	1.845 G	1.00 M	1.452289 G	-40.36	-27.36	1.845 G	3.000 G	1.00 M	2.912677 G	-39.43	-26.43	3.000 G	7.000 G	1.00 M	3.102000 G	-36.29	-23.29	7.000 G	13.600 G	1.00 M	10.233600 G	-33.14	-20.14	13.600 G	19.100 G	1.00 M	15.344875 G	-24.50	-11.50
Start [Hz]	Stop [Hz]	RBW [Hz]	Freq [Hz]	PwrAve [dBm]	ΔLimit [dB]																																																																																
30.000 M	1.000 G	1.00 M	141.792500 M	-38.52	-25.52																																																																																
1.000 G	1.845 G	1.00 M	1.233886 G	-39.93	-26.93																																																																																
1.845 G	3.000 G	1.00 M	2.995660 G	-39.08	-26.08																																																																																
3.000 G	7.000 G	1.00 M	3.115000 G	-36.31	-23.31																																																																																
7.000 G	13.600 G	1.00 M	10.216975 G	-33.07	-20.07																																																																																
13.600 G	19.100 G	1.00 M	15.160825 G	-24.94	-11.94																																																																																
Start [Hz]	Stop [Hz]	RBW [Hz]	Freq [Hz]	PwrAve [dBm]	ΔLimit [dB]																																																																																
30.000 M	1.000 G	1.00 M	141.792500 M	-37.39	-24.39																																																																																
1.000 G	1.845 G	1.00 M	1.452289 G	-40.36	-27.36																																																																																
1.845 G	3.000 G	1.00 M	2.912677 G	-39.43	-26.43																																																																																
3.000 G	7.000 G	1.00 M	3.102000 G	-36.29	-23.29																																																																																
7.000 G	13.600 G	1.00 M	10.233600 G	-33.14	-20.14																																																																																
13.600 G	19.100 G	1.00 M	15.344875 G	-24.50	-11.50																																																																																
Highest Channel	Highest Channel																																																																																				
 <table border="1" data-bbox="239 1601 638 1702"> <thead> <tr> <th>Start [Hz]</th> <th>Stop [Hz]</th> <th>RBW [Hz]</th> <th>Freq [Hz]</th> <th>PwrAve [dBm]</th> <th>ΔLimit [dB]</th> </tr> </thead> <tbody> <tr><td>30.000 M</td><td>1.000 G</td><td>1.00 M</td><td>171.377500 M</td><td>-36.93</td><td>-23.93</td></tr> <tr><td>1.000 G</td><td>1.845 G</td><td>1.00 M</td><td>1.281396 G</td><td>-40.22</td><td>-27.22</td></tr> <tr><td>1.845 G</td><td>3.000 G</td><td>1.00 M</td><td>1.913271 G</td><td>-32.00</td><td>-19.00</td></tr> <tr><td>3.000 G</td><td>7.000 G</td><td>1.00 M</td><td>3.042000 G</td><td>-36.40</td><td>-23.40</td></tr> <tr><td>7.000 G</td><td>13.600 G</td><td>1.00 M</td><td>10.229050 G</td><td>-33.51</td><td>-20.51</td></tr> <tr><td>13.600 G</td><td>19.100 G</td><td>1.00 M</td><td>15.243312 G</td><td>-24.56</td><td>-11.56</td></tr> </tbody> </table> <p>Date: 13.AUG.2015 10:35:25</p>	Start [Hz]	Stop [Hz]	RBW [Hz]	Freq [Hz]	PwrAve [dBm]	ΔLimit [dB]	30.000 M	1.000 G	1.00 M	171.377500 M	-36.93	-23.93	1.000 G	1.845 G	1.00 M	1.281396 G	-40.22	-27.22	1.845 G	3.000 G	1.00 M	1.913271 G	-32.00	-19.00	3.000 G	7.000 G	1.00 M	3.042000 G	-36.40	-23.40	7.000 G	13.600 G	1.00 M	10.229050 G	-33.51	-20.51	13.600 G	19.100 G	1.00 M	15.243312 G	-24.56	-11.56	 <table border="1" data-bbox="888 1601 1287 1702"> <thead> <tr> <th>Start [Hz]</th> <th>Stop [Hz]</th> <th>RBW [Hz]</th> <th>Freq [Hz]</th> <th>PwrAve [dBm]</th> <th>ΔLimit [dB]</th> </tr> </thead> <tbody> <tr><td>30.000 M</td><td>1.000 G</td><td>1.00 M</td><td>171.422500 M</td><td>-34.76</td><td>-21.76</td></tr> <tr><td>1.000 G</td><td>1.845 G</td><td>1.00 M</td><td>1.189280 G</td><td>-39.69</td><td>-26.69</td></tr> <tr><td>1.845 G</td><td>3.000 G</td><td>1.00 M</td><td>1.913271 G</td><td>-33.32</td><td>-20.32</td></tr> <tr><td>3.000 G</td><td>7.000 G</td><td>1.00 M</td><td>3.044000 G</td><td>-36.32</td><td>-23.32</td></tr> <tr><td>7.000 G</td><td>13.600 G</td><td>1.00 M</td><td>10.219150 G</td><td>-32.97</td><td>-19.97</td></tr> <tr><td>13.600 G</td><td>19.100 G</td><td>1.00 M</td><td>15.323363 G</td><td>-24.86</td><td>-11.86</td></tr> </tbody> </table> <p>Date: 13.AUG.2015 10:44:33</p>	Start [Hz]	Stop [Hz]	RBW [Hz]	Freq [Hz]	PwrAve [dBm]	ΔLimit [dB]	30.000 M	1.000 G	1.00 M	171.422500 M	-34.76	-21.76	1.000 G	1.845 G	1.00 M	1.189280 G	-39.69	-26.69	1.845 G	3.000 G	1.00 M	1.913271 G	-33.32	-20.32	3.000 G	7.000 G	1.00 M	3.044000 G	-36.32	-23.32	7.000 G	13.600 G	1.00 M	10.219150 G	-32.97	-19.97	13.600 G	19.100 G	1.00 M	15.323363 G	-24.86	-11.86
Start [Hz]	Stop [Hz]	RBW [Hz]	Freq [Hz]	PwrAve [dBm]	ΔLimit [dB]																																																																																
30.000 M	1.000 G	1.00 M	171.377500 M	-36.93	-23.93																																																																																
1.000 G	1.845 G	1.00 M	1.281396 G	-40.22	-27.22																																																																																
1.845 G	3.000 G	1.00 M	1.913271 G	-32.00	-19.00																																																																																
3.000 G	7.000 G	1.00 M	3.042000 G	-36.40	-23.40																																																																																
7.000 G	13.600 G	1.00 M	10.229050 G	-33.51	-20.51																																																																																
13.600 G	19.100 G	1.00 M	15.243312 G	-24.56	-11.56																																																																																
Start [Hz]	Stop [Hz]	RBW [Hz]	Freq [Hz]	PwrAve [dBm]	ΔLimit [dB]																																																																																
30.000 M	1.000 G	1.00 M	171.422500 M	-34.76	-21.76																																																																																
1.000 G	1.845 G	1.00 M	1.189280 G	-39.69	-26.69																																																																																
1.845 G	3.000 G	1.00 M	1.913271 G	-33.32	-20.32																																																																																
3.000 G	7.000 G	1.00 M	3.044000 G	-36.32	-23.32																																																																																
7.000 G	13.600 G	1.00 M	10.219150 G	-32.97	-19.97																																																																																
13.600 G	19.100 G	1.00 M	15.323363 G	-24.86	-11.86																																																																																



Frequency Stability

Test Conditions	Middle Channel	GSM850 (GPRS class 8)	GSM850 (EDGE class 8)	Limit 2.5ppm
Temperature (°C)	Voltage (Volt)	Deviation (ppm)		Result
50	Normal Voltage	0.0048	0.0036	PASS
40	Normal Voltage	0.0024	0.0060	
30	Normal Voltage	0.0048	0.0012	
20(Ref.)	Normal Voltage	0.0000	0.0000	
10	Normal Voltage	0.0024	0.0060	
0	Normal Voltage	0.0084	0.0036	
-10	Normal Voltage	0.0120	0.0084	
-20	Normal Voltage	0.0072	0.0096	
-30	Normal Voltage	0.0012	0.0048	
20	Maximum Voltage	0.0036	0.0012	
20	Normal Voltage	0.0012	0.0048	
20	Battery End Point	0.0060	0.0060	



Test Conditions	Middle Channel	GSM1900 (GPRS class 8)	GSM1900 (EDGE class 8)	Limit Note 2.
Temperature (°C)	Voltage (Volt)	Deviation (ppm)		Result
50	Normal Voltage	0.0085	0.0096	PASS
40	Normal Voltage	0.0069	0.0080	
30	Normal Voltage	0.0027	0.0016	
20(Ref.)	Normal Voltage	0.0000	0.0000	
10	Normal Voltage	0.0021	0.0048	
0	Normal Voltage	0.0053	0.0043	
-10	Normal Voltage	0.0005	0.0027	
-20	Normal Voltage	0.0048	0.0037	
-30	Normal Voltage	0.0037	0.0005	
20	Maximum Voltage	0.0016	0.0016	
20	Normal Voltage	0.0011	0.0037	
20	Battery End Point	0.0011	0.0032	

Note:

1. Normal Voltage = 3.8V. ; Battery End Point (BEP) = 3.6 V. ; Maximum Voltage =4.2 V
2. The frequency fundamental emissions stay within the authorized frequency block.



A2. WCDMA

Peak-to-Average Ratio

Mode	WCDMA Band V	WCDMA Band II		Limit: 13dB
Mod.	RMC 12.2Kbps	RMC 12.2Kbps		Result
Lowest CH	3.12	3.36		PASS
Middle CH	3.16	3.04		
Highest CH	3.32	3.16		

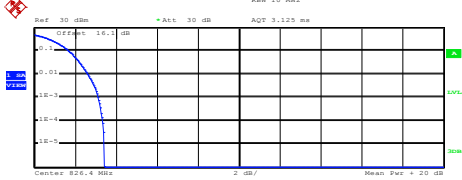
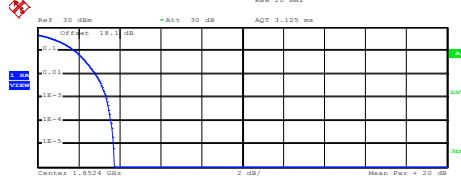
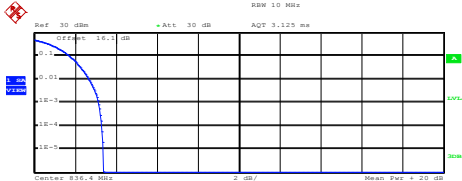
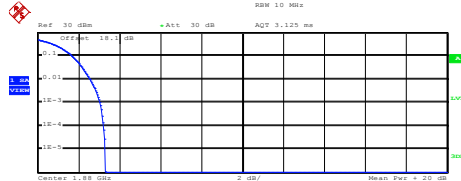
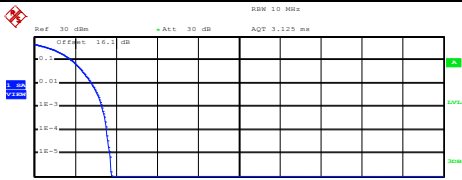
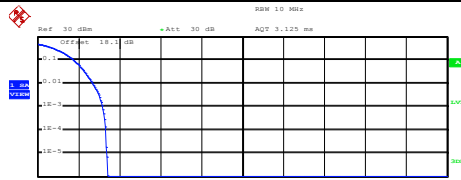

WCDMA Band V (RMC 12.2Kbps)	WCDMA Band II (RMC 12.2Kbps)																
<p style="text-align: center;">Lowest Channel</p>  <p>Center 826.4 MHz</p> <p>Complementary Cumulative Distribution Function (100000 samples) Trace 1 Mean 19.78 dBm Peak 23.20 dBm Crest 3.42 dB</p> <table border="1"> <tr><td>10 %</td><td>1.68 dB</td></tr> <tr><td>1 %</td><td>2.60 dB</td></tr> <tr><td>.1 %</td><td>3.12 dB</td></tr> <tr><td>.01 %</td><td>3.36 dB</td></tr> </table> <p>Date: 13.AUG.2015 11:09:50</p>	10 %	1.68 dB	1 %	2.60 dB	.1 %	3.12 dB	.01 %	3.36 dB	<p style="text-align: center;">Lowest Channel</p>  <p>Center 1.8524 GHz</p> <p>Complementary Cumulative Distribution Function (100000 samples) Trace 1 Mean 19.86 dBm Peak 23.62 dBm Crest 3.76 dB</p> <table border="1"> <tr><td>10 %</td><td>1.84 dB</td></tr> <tr><td>1 %</td><td>2.84 dB</td></tr> <tr><td>.1 %</td><td>3.36 dB</td></tr> <tr><td>.01 %</td><td>3.56 dB</td></tr> </table> <p>Date: 13.AUG.2015 10:57:49</p>	10 %	1.84 dB	1 %	2.84 dB	.1 %	3.36 dB	.01 %	3.56 dB
10 %	1.68 dB																
1 %	2.60 dB																
.1 %	3.12 dB																
.01 %	3.36 dB																
10 %	1.84 dB																
1 %	2.84 dB																
.1 %	3.36 dB																
.01 %	3.56 dB																
<p style="text-align: center;">Middle Channel</p>  <p>Center 836.4 MHz</p> <p>Complementary Cumulative Distribution Function (100000 samples) Trace 1 Mean 19.75 dBm Peak 23.13 dBm Crest 3.37 dB</p> <table border="1"> <tr><td>10 %</td><td>1.72 dB</td></tr> <tr><td>1 %</td><td>2.68 dB</td></tr> <tr><td>.1 %</td><td>3.16 dB</td></tr> <tr><td>.01 %</td><td>3.32 dB</td></tr> </table> <p>Date: 13.AUG.2015 11:10:00</p>	10 %	1.72 dB	1 %	2.68 dB	.1 %	3.16 dB	.01 %	3.32 dB	<p style="text-align: center;">Middle Channel</p>  <p>Center 1.88 GHz</p> <p>Complementary Cumulative Distribution Function (100000 samples) Trace 1 Mean 20.60 dBm Peak 23.90 dBm Crest 3.31 dB</p> <table border="1"> <tr><td>10 %</td><td>1.68 dB</td></tr> <tr><td>1 %</td><td>2.56 dB</td></tr> <tr><td>.1 %</td><td>3.04 dB</td></tr> <tr><td>.01 %</td><td>3.24 dB</td></tr> </table> <p>Date: 13.AUG.2015 10:58:00</p>	10 %	1.68 dB	1 %	2.56 dB	.1 %	3.04 dB	.01 %	3.24 dB
10 %	1.72 dB																
1 %	2.68 dB																
.1 %	3.16 dB																
.01 %	3.32 dB																
10 %	1.68 dB																
1 %	2.56 dB																
.1 %	3.04 dB																
.01 %	3.24 dB																
<p style="text-align: center;">Highest Channel</p>  <p>Center 846.6 MHz</p> <p>Complementary Cumulative Distribution Function (100000 samples) Trace 1 Mean 23.45 dBm Peak 27.22 dBm Crest 3.76 dB</p> <table border="1"> <tr><td>10 %</td><td>1.84 dB</td></tr> <tr><td>1 %</td><td>2.80 dB</td></tr> <tr><td>.1 %</td><td>3.32 dB</td></tr> <tr><td>.01 %</td><td>3.56 dB</td></tr> </table> <p>Date: 13.AUG.2015 11:10:28</p>	10 %	1.84 dB	1 %	2.80 dB	.1 %	3.32 dB	.01 %	3.56 dB	<p style="text-align: center;">Highest Channel</p>  <p>Center 1.9076 GHz</p> <p>Complementary Cumulative Distribution Function (100000 samples) Trace 1 Mean 20.27 dBm Peak 23.69 dBm Crest 3.42 dB</p> <table border="1"> <tr><td>10 %</td><td>1.76 dB</td></tr> <tr><td>1 %</td><td>2.68 dB</td></tr> <tr><td>.1 %</td><td>3.16 dB</td></tr> <tr><td>.01 %</td><td>3.32 dB</td></tr> </table> <p>Date: 13.AUG.2015 10:58:09</p>	10 %	1.76 dB	1 %	2.68 dB	.1 %	3.16 dB	.01 %	3.32 dB
10 %	1.84 dB																
1 %	2.80 dB																
.1 %	3.32 dB																
.01 %	3.56 dB																
10 %	1.76 dB																
1 %	2.68 dB																
.1 %	3.16 dB																
.01 %	3.32 dB																



26dB Bandwidth

Mode	WCDMA Band V	WCDMA Band II	
Mod.	RMC 12.2Kbps	RMC 12.2Kbps	
Lowest CH	4.72	4.71	
Middle CH	4.71	4.74	
Highest CH	4.66	4.71	

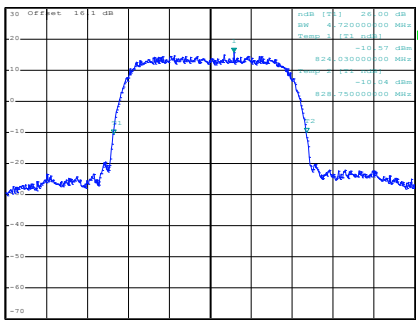
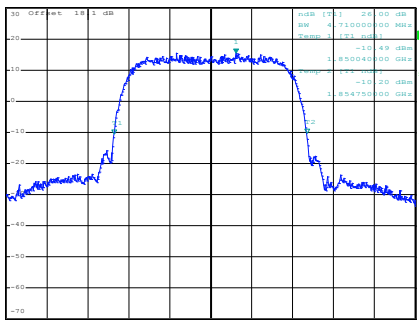
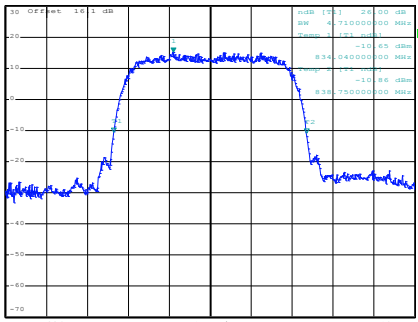
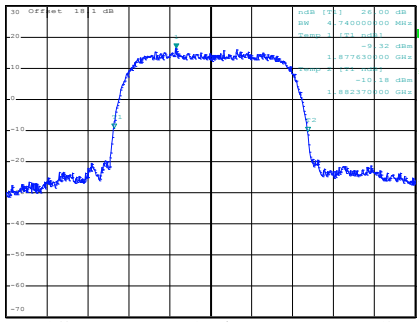
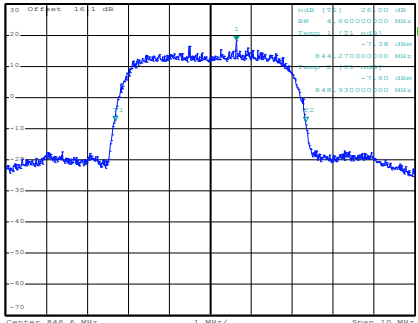
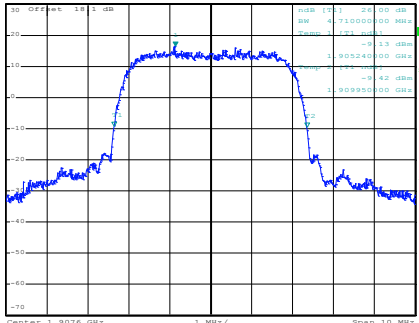

WCDMA Band V (RMC 12.2Kbps)	WCDMA Band II (RMC 12.2Kbps)
<p style="text-align: center;">Lowest Channel</p>  <p>Date: 13.AUG.2015 11:00:52</p>	<p style="text-align: center;">Lowest Channel</p>  <p>Date: 13.AUG.2015 10:49:24</p>
<p style="text-align: center;">Middle Channel</p>  <p>Date: 13.AUG.2015 11:01:20</p>	<p style="text-align: center;">Middle Channel</p>  <p>Date: 13.AUG.2015 10:49:52</p>
<p style="text-align: center;">Highest Channel</p>  <p>Date: 13.AUG.2015 11:01:48</p>	<p style="text-align: center;">Highest Channel</p>  <p>Date: 13.AUG.2015 10:50:20</p>



Occupied Bandwidth

Mode	WCDMA Band V	WCDMA Band II	
Mod.	RMC 12.2Kbps	RMC 12.2Kbps	
Lowest CH	4.15	4.15	
Middle CH	4.15	4.16	
Highest CH	4.15	4.16	

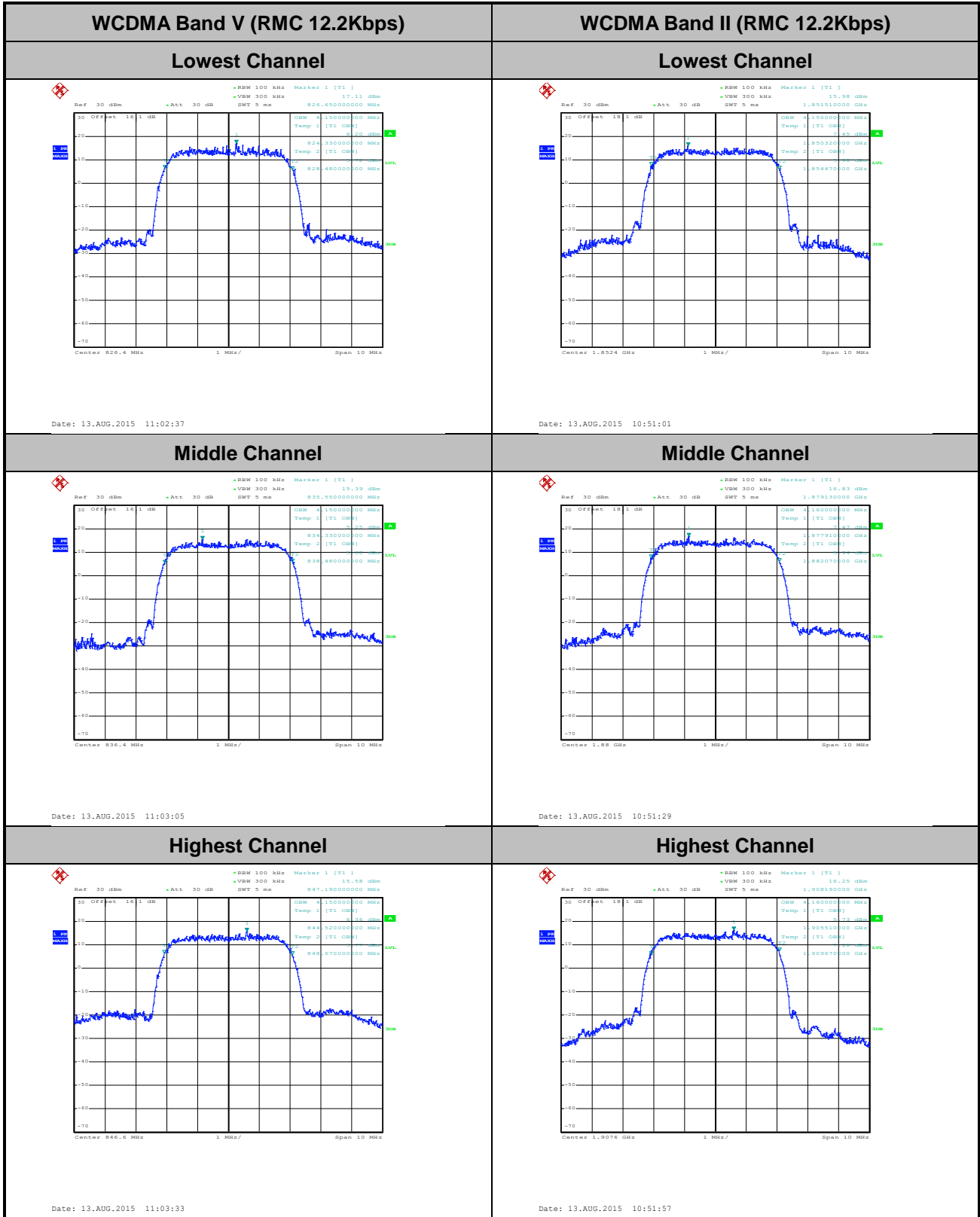



Conducted Band Edge



WCDMA Band V (RMC 12.2Kbps)

Lowest Band Edge

Highest Band Edge

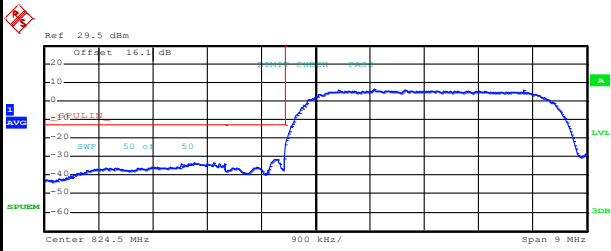

Center 824.5 MHz 900 kHz/ Span 9 MHz

Start [Hz]	Stop [Hz]	RBW [Hz]	Freq [Hz]	PwrAbs [dBm]	ΔLimit [dB]
820.000 M	823.000 M	100.00 k	822.487000 M	-33.14	-20.14
823.000 M	824.000 M	50.00 k	823.840000 M	-31.40	-18.40
824.000 M	829.000 M	100.00 k	825.460000 M	6.66	-28.34

Date: 13.AUG.2015 11:05:38

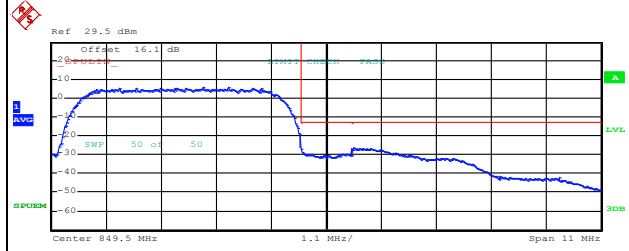

Center 849.5 MHz 1.1 MHz/ Span 11 MHz

Start [Hz]	Stop [Hz]	RBW [Hz]	Freq [Hz]	PwrAbs [dBm]	ΔLimit [dB]
844.000 M	849.000 M	100.00 k	847.530000 M	5.64	-29.36
849.000 M	850.000 M	50.00 k	849.004000 M	-26.85	-13.85
850.000 M	855.000 M	100.00 k	850.035000 M	-26.50	-13.50

Date: 13.AUG.2015 11:07:05



WCDMA Band II (RMC 12.2Kbps)

Lowest Band Edge

Highest Band Edge

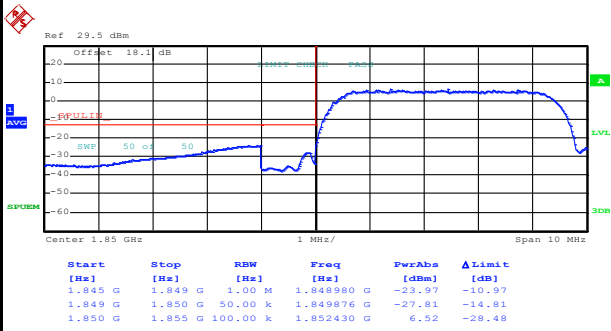

Date: 13.AUG.2015 10:53:26

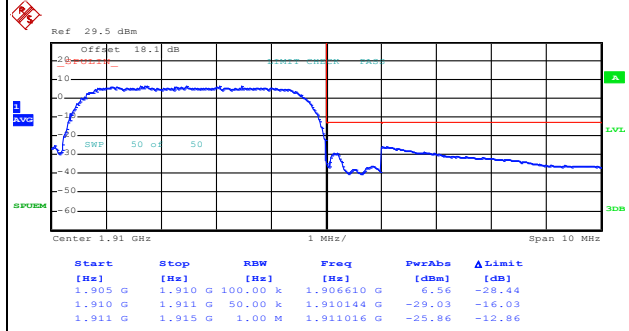

Date: 13.AUG.2015 10:54:53



Conducted Spurious Emission

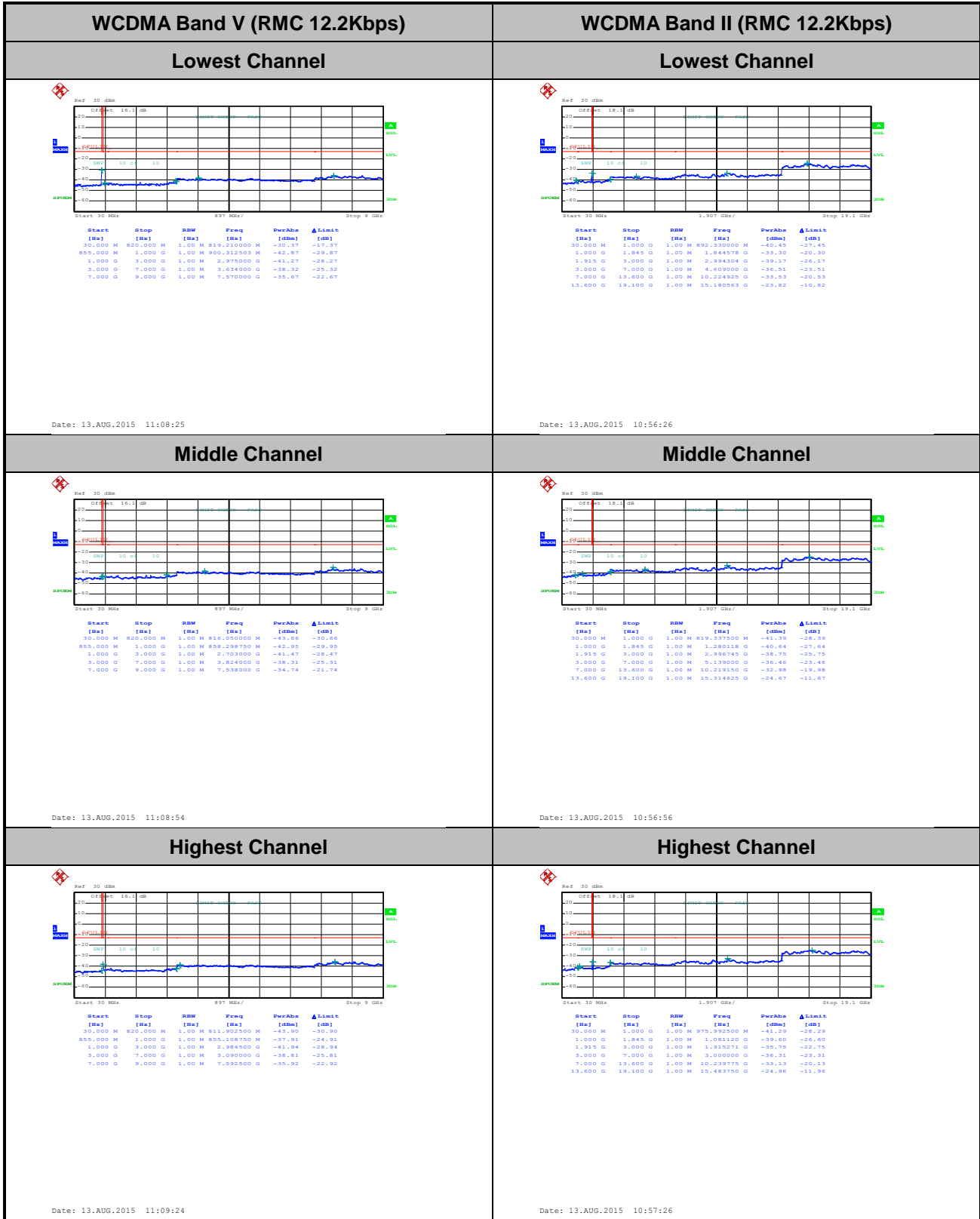



Frequency Stability

Test Conditions	Middle Channel	WCDMA Band V (RMC 12.2Kbps)	Limit 2.5ppm
Temperature (°C)	Voltage (Volt)	Deviation (ppm)	Result
50	Normal Voltage	0.0012	PASS
40	Normal Voltage	0.0143	
30	Normal Voltage	0.0108	
20(Ref.)	Normal Voltage	0.0000	
10	Normal Voltage	0.0120	
0	Normal Voltage	0.0048	
-10	Normal Voltage	0.0108	
-20	Normal Voltage	0.0155	
-30	Normal Voltage	0.0132	
20	Maximum Voltage	0.0012	
20	Normal Voltage	0.0096	
20	Battery End Point	0.0167	



Test Conditions	Middle Channel	WCDMA Band II (RMC 12.2Kbps)	Limit Note 2.
Temperature (°C)	Voltage (Volt)	Deviation (ppm)	Result
50	Normal Voltage	0.0005	PASS
40	Normal Voltage	0.0005	
30	Normal Voltage	0.0027	
20(Ref.)	Normal Voltage	0.0000	
10	Normal Voltage	0.0016	
0	Normal Voltage	0.0027	
-10	Normal Voltage	0.0011	
-20	Normal Voltage	0.0021	
-30	Normal Voltage	0.0032	
20	Maximum Voltage	0.0037	
20	Normal Voltage	0.0032	
20	Battery End Point	0.0053	

Note:

- 1. Normal Voltage = 3.8V. ; Battery End Point (BEP) = 3.6 V. ; Maximum Voltage =4.2 V
- 2. The frequency fundamental emissions stay within the authorized frequency block.



Appendix B. Test Results of Radiated Test

ERP/EIRP

Channel	Mode	Horizontal		Vertical	
		ERP(dBm)	ERP(W)	ERP(dBm)	ERP(W)
Lowest	GSM850 GPRS class 8	24.53	0.2838	13.95	0.0248
Middle		24.56	0.2858	14.62	0.0290
Highest		24.78	0.3006	15.64	0.0366
Lowest	GSM850 EDGE class 8	20.48	0.1117	9.92	0.0098
Middle		20.15	0.1035	10.60	0.0115
Highest		20.58	0.1143	11.57	0.0144
Lowest	WCDMA Band V RMC 12.2Kbps	17.80	0.0603	7.58	0.0057
Middle		17.80	0.0603	8.19	0.0066
Highest		18.05	0.0638	8.72	0.0074
Limit	ERP < 7W	Result		PASS	



Channel	Mode	Horizontal		Vertical	
		EIRP(dBm)	EIRP(W)	EIRP(dBm)	EIRP(W)
Lowest	GSM1900 GPRS class 8	24.93	0.3112	24.44	0.2780
Middle		25.66	0.3681	24.35	0.2723
Highest		26.15	0.4121	24.32	0.2704
Lowest	GSM1900 EDGE class 8	23.31	0.2143	21.74	0.1493
Middle		24.02	0.2523	22.16	0.1644
Highest		24.34	0.2716	21.96	0.1570
Lowest	WCDMA Band II RMC 12.2Kbps	17.92	0.0619	16.69	0.0467
Middle		18.79	0.0757	16.95	0.0495
Highest		19.46	0.0883	17.30	0.0537
Limit	EIRP < 2W	Result		PASS	



Radiated Spurious Emission

GSM850 (GPRS class 8)									
Channel	Frequency (MHz)	ERP (dBm)	Limit (dBm)	Over Limit (dB)	SPA Reading (dBm)	S.G. Power (dBm)	TX Cable loss (dB)	TX Antenna Gain (dBi)	Polarization (H/V)
Lowest	1651	-67.19	-13	-54.19	-71.65	-68.94	0.98	4.88	H
	2476	-59.83	-13	-46.83	-68.97	-61.72	1.28	5.33	H
	4125	-60.89	-13	-47.89	-77.49	-65.53	1.83	8.63	H
	1651	-69.87	-13	-56.87	-72.9	-71.62	0.98	4.88	V
	2476	-59.28	-13	-46.28	-69.41	-61.17	1.28	5.33	V
	4125	-62.47	-13	-49.47	-77.8	-67.11	1.83	8.63	V
Middle	1675	-68.64	-13	-55.64	-72.99	-70.31	0.99	4.81	H
	2512	-61.47	-13	-48.47	-70.78	-63.44	1.29	5.41	H
	4185	-61.23	-13	-48.23	-76.75	-65.85	1.87	8.64	H
	1672	-70.88	-13	-57.88	-73.66	-72.56	0.99	4.82	V
	2509	-62.26	-13	-49.26	-72.21	-64.22	1.29	5.41	V
	4185	-61.40	-13	-48.40	-77.01	-66.02	1.87	8.64	V
Highest	1702	-66.34	-13	-53.34	-70.77	-67.92	1.00	4.73	H
	2548	-63.08	-13	-50.08	-72.43	-65.06	1.31	5.44	H
	3395	-65.12	-13	-52.12	-77.11	-68.94	1.57	7.54	H
	1702	-69.36	-13	-56.36	-72.88	-70.94	1.00	4.73	V
	2548	-64.84	-13	-51.84	-74.81	-66.82	1.31	5.44	V
	3395	-65.57	-13	-52.57	-77.1	-69.39	1.57	7.54	V

Remark: Spurious emissions within 30-1000MHz were found more than 20dB below limit line.



GSM850 (EDGE class 8)									
Channel	Frequency (MHz)	ERP (dBm)	Limit (dBm)	Over Limit (dB)	SPA Reading (dBm)	S.G. Power (dBm)	TX Cable loss (dB)	TX Antenna Gain (dBi)	Polarization (H/V)
Lowest	1648	-68.61	-13	-55.61	-73.09	-70.37	0.98	4.89	H
	2472	-64.33	-13	-51.33	-73.16	-66.21	1.28	5.32	H
	3296	-64.10	-13	-51.10	-76.02	-67.51	1.54	7.10	H
	1648	-69.09	-13	-56.09	-72.11	-70.85	0.98	4.89	V
	2472	-64.64	-13	-51.64	-74.61	-66.52	1.28	5.32	V
	3296	-65.08	-13	-52.08	-75.92	-68.49	1.54	7.10	V
Middle	1672	-66.26	-13	-53.26	-70.53	-67.94	0.99	4.82	H
	2512	-66.24	-13	-53.24	-74.23	-68.21	1.29	5.41	H
	3345	-64.07	-13	-51.07	-75.45	-67.68	1.56	7.32	H
	1672	-69.94	-13	-56.94	-72.09	-71.62	0.99	4.82	V
	2508	-63.85	-13	-50.85	-74.08	-65.81	1.29	5.41	V
	3344	-65.04	-13	-52.04	-75.52	-68.65	1.56	7.31	V
Highest	1696	-67.81	-13	-54.81	-71.85	-69.41	1.00	4.75	H
	2544	-64.53	-13	-51.53	-74.1	-66.51	1.30	5.44	H
	3392	-64.16	-13	-51.16	-75.96	-67.96	1.57	7.52	H
	1696	-70.29	-13	-57.29	-73.58	-71.89	1.00	4.75	V
	2544	-67.73	-13	-54.73	-74.94	-69.71	1.30	5.44	V
	3392	-66.71	-13	-53.71	-75.95	-70.51	1.57	7.52	V

Remark: Spurious emissions within 30-1000MHz were found more than 20dB below limit line.



GSM1900 (GPRS class 8)									
Channel	Frequency (MHz)	EIRP (dBm)	Limit (dBm)	Over Limit (dB)	SPA Reading (dBm)	S.G. Power (dBm)	TX Cable loss (dB)	TX Antenna Gain (dBi)	Polarization (H/V)
Lowest	3700	-63.35	-13	-50.35	-76.89	-69.92	1.67	8.24	H
	5550	-59.16	-13	-46.16	-78.36	-66.23	2.65	9.72	H
	7400	-53.04	-13	-40.04	-77.64	-62.18	2.46	11.60	H
	3700	-63.61	-13	-50.61	-77.04	-70.18	1.67	8.24	V
	5550	-60.74	-13	-47.74	-78.35	-67.81	2.65	9.72	V
	7400	-54.61	-13	-41.61	-77.9	-63.75	2.46	11.60	V
Middle	3763	-62.70	-13	-49.70	-76.67	-69.33	1.69	8.32	H
	5640	-59.23	-13	-46.23	-78.16	-66.28	2.71	9.76	H
	7520	-53.78	-13	-40.78	-77.8	-63.17	2.42	11.81	H
	3763	-63.69	-13	-50.69	-76.98	-70.32	1.69	8.32	V
	5640	-60.78	-13	-47.78	-78.23	-67.83	2.71	9.76	V
	7520	-54.40	-13	-41.40	-77.56	-63.79	2.42	11.81	V
Highest	3819	-63.30	-13	-50.30	-77.21	-69.98	1.70	8.38	H
	5729	-58.88	-13	-45.88	-78.05	-65.91	2.76	9.79	H
	7639	-54.19	-13	-41.19	-77.9	-63.69	2.38	11.88	H
	3819	-63.73	-13	-50.73	-76.93	-70.41	1.70	8.38	V
	5729	-60.72	-13	-47.72	-77.88	-67.75	2.76	9.79	V
	7639	-54.81	-13	-41.81	-77.85	-64.31	2.38	11.88	V

Remark: Spurious emissions within 30-1000MHz were found more than 20dB below limit line.



GSM1900 (EDGE class 8)									
Channel	Frequency (MHz)	EIRP (dBm)	Limit (dBm)	Over Limit (dB)	SPA Reading (dBm)	S.G. Power (dBm)	TX Cable loss (dB)	TX Antenna Gain (dBi)	Polarization (H/V)
Lowest	3700	-63.36	-13	-50.36	-76.93	-69.93	1.67	8.24	H
	5550	-59.32	-13	-46.32	-78.46	-66.39	2.65	9.72	H
	7400	-53.27	-13	-40.27	-77.88	-62.41	2.46	11.60	H
	3700	-63.51	-13	-50.51	-76.93	-70.08	1.67	8.24	V
	5550	-60.71	-13	-47.71	-78.33	-67.78	2.65	9.72	V
	7400	-54.58	-13	-41.58	-77.97	-63.72	2.46	11.60	V
Middle	3763	-63.30	-13	-50.30	-77.15	-69.93	1.69	8.32	H
	5640	-59.67	-13	-46.67	-78.61	-66.72	2.71	9.76	H
	7520	-54.14	-13	-41.14	-78.19	-63.53	2.42	11.81	H
	3763	-63.73	-13	-50.73	-77.02	-70.36	1.69	8.32	V
	5640	-61.08	-13	-48.08	-78.57	-68.13	2.71	9.76	V
	7520	-54.72	-13	-41.72	-77.89	-64.11	2.42	11.81	V
Highest	3819	-63.44	-13	-50.44	-77.25	-70.12	1.70	8.38	H
	5729	-59.10	-13	-46.10	-78.26	-66.13	2.76	9.79	H
	7639	-54.21	-13	-41.21	-77.98	-63.71	2.38	11.88	H
	3819	-63.86	-13	-50.86	-77.02	-70.54	1.70	8.38	V
	5729	-60.23	-13	-47.23	-78.28	-67.26	2.76	9.79	V
	7639	-55.01	-13	-42.01	-78.02	-64.51	2.38	11.88	V

Remark: Spurious emissions within 30-1000MHz were found more than 20dB below limit line.



WCDMA Band V(RMC 12.2Kbps)									
Channel	Frequency (MHz)	ERP (dBm)	Limit (dBm)	Over Limit (dB)	SPA Reading (dBm)	S.G. Power (dBm)	TX Cable loss (dB)	TX Antenna Gain (dBi)	Polarization (H/V)
Lowest	1656	-69.70	-13	-56.70	-74.08	-71.43	0.98	4.86	H
	2480	-65.91	-13	-52.91	-74.8	-67.82	1.28	5.34	H
	3304	-63.81	-13	-50.81	-75.64	-67.25	1.54	7.14	H
	1656	-71.43	-13	-58.43	-74.2	-73.16	0.98	4.86	V
	2480	-65.21	-13	-52.21	-75.11	-67.12	1.28	5.34	V
	3304	-65.03	-13	-52.03	-75.95	-68.47	1.54	7.14	V
Middle	1672	-69.96	-13	-56.96	-74.23	-71.64	0.99	4.82	H
	2512	-65.96	-13	-52.96	-74.95	-67.93	1.29	5.41	H
	3344	-64.24	-13	-51.24	-75.97	-67.85	1.56	7.31	H
	1672	-71.47	-13	-58.47	-74.17	-73.15	0.99	4.82	V
	2512	-64.94	-13	-51.94	-74.83	-66.91	1.29	5.41	V
	3344	-64.95	-13	-51.95	-75.95	-68.56	1.56	7.31	V
Highest	1696	-69.82	-13	-56.82	-74.13	-71.42	1.00	4.75	H
	2536	-66.23	-13	-53.23	-75.3	-68.21	1.30	5.43	H
	3384	-64.18	-13	-51.18	-76.19	-67.95	1.57	7.49	H
	1696	-70.87	-13	-57.87	-74.24	-72.47	1.00	4.75	V
	2536	-65.33	-13	-52.33	-75.19	-67.31	1.30	5.43	V
	3384	-64.74	-13	-51.74	75.71	-68.51	1.57	7.49	V

Remark: Spurious emissions within 30-1000MHz were found more than 20dB below limit line.



WCDMA Band II(RMC 12.2Kbps)									
Channel	Frequency (MHz)	EIRP (dBm)	Limit (dBm)	Over Limit (dB)	SPA Reading (dBm)	S.G. Power (dBm)	TX Cable loss (dB)	TX Antenna Gain (dBi)	Polarization (H/V)
Lowest	3707	-62.35	-13	-49.35	-75.91	-68.93	1.67	8.25	H
	5557	-58.86	-13	-45.86	-78.03	-65.92	2.66	9.72	H
	7410	-54.06	-13	-41.06	-78.61	-63.22	2.46	11.62	H
	3707	-62.64	-13	-49.64	-76.05	-69.22	1.67	8.25	V
	5557	-60.33	-13	-47.33	-77.93	-67.39	2.66	9.72	V
	7410	-55.27	-13	-42.27	-78.59	-64.43	2.46	11.62	V
Middle	3763	-63.48	-13	-50.48	-77.2	-70.11	1.69	8.32	H
	5640	-59.54	-13	-46.54	-78.45	-66.59	2.71	9.76	H
	7520	-54.00	-13	-41.00	-78.04	-63.39	2.42	11.81	H
	3763	-63.69	-13	-50.69	-76.99	-70.32	1.69	8.32	V
	5640	-60.88	-13	-47.88	-78.36	-67.93	2.71	9.76	V
	7520	-55.13	-13	-42.13	-78.24	-64.52	2.42	11.81	V
Highest	3819	-63.25	-13	-50.25	-77.06	-69.93	1.70	8.38	H
	5726	-59.64	-13	-46.64	-78.81	-66.68	2.76	9.79	H
	7635	-54.31	-13	-41.31	-78.04	-63.81	2.39	11.88	H
	3819	-64.00	-13	-51.00	-77.19	-70.68	1.70	8.38	V
	5726	-60.18	-13	-47.18	-78.21	-67.22	2.76	9.79	V
	7635	-54.98	-13	-41.98	-78.04	-64.48	2.39	11.88	V

Remark: Spurious emissions within 30-1000MHz were found more than 20dB below limit line.