



FCC RF Test Report

APPLICANT : Sony Mobile Communications Inc.
EQUIPMENT : GSM/WCDMA/LTE Phone + Bluetooth, DTS/UNII
a/b/g/n/ac, ANT+, and NFC
BRAND NAME : Sony
FCC ID : PY7-PM0902
STANDARD : FCC Part 15 Subpart C §15.247
CLASSIFICATION : (DTS) Digital Transmission System

The product was received on Jul. 16, 2015 and testing was completed on Aug. 26, 2015. We, SPORTON INTERNATIONAL INC., would like to declare that the tested sample has been evaluated in accordance with the test procedures and has been in compliance with the applicable technical standards.

The test results in this report apply exclusively to the tested model / sample. Without written approval of SPORTON INTERNATIONAL INC., the test report shall not be reproduced except in full.

Reviewed by: Joseph Lin / Supervisor

Approved by: Jones Tsai / Manager



SPORTON INTERNATIONAL INC.

No. 52, Hwa Ya 1st Rd., Hwa Ya Technology Park, Kwei-Shan District, Tao Yuan City, Taiwan, R.O.C.



TABLE OF CONTENTS

REVISION HISTORY.....3

SUMMARY OF TEST RESULT4

1 GENERAL DESCRIPTION.....5

 1.1 Applicant.....5

 1.2 Manufacturer.....5

 1.3 Product Feature of Equipment Under Test.....5

 1.4 Modification of EUT6

 1.5 Testing Location6

 1.6 Applicable Standards.....7

2 TEST CONFIGURATION OF EQUIPMENT UNDER TEST.....8

 2.1 Carrier Frequency and Channel8

 2.2 Pre-Scanned RF Power.....9

 2.3 Test Mode.....11

 2.4 Connection Diagram of Test System.....12

 2.5 Support Unit used in test configuration and system12

 2.6 EUT Operation Test Setup13

 2.7 Measurement Results Explanation Example.....13

3 TEST RESULT.....14

 3.1 6dB Bandwidth Measurement14

 3.2 Peak Output Power Measurement16

 3.3 Power Spectral Density Measurement17

 3.4 Conducted Band Edges and Spurious Emission Measurement19

 3.5 Radiated Band Edges and Spurious Emission Measurement50

 3.6 AC Conducted Emission Measurement.....54

 3.7 Antenna Requirements.....58

4 LIST OF MEASURING EQUIPMENT60

5 UNCERTAINTY OF EVALUATION.....62

APPENDIX A. CONDUCTED TEST RESULTS

APPENDIX B. RADIATED TEST RESULTS

APPENDIX C. RADIATED SPURIOUS EMISSION PLOTS



SUMMARY OF TEST RESULT

Report Section	FCC Rule	Description	Limit	Result	Remark
3.1	15.247(a)(2)	6dB Bandwidth	$\geq 0.5\text{MHz}$	Pass	-
3.2	15.247(b)	Power Output Measurement	$\leq 30\text{dBm}$	Pass	-
3.3	15.247(e)	Power Spectral Density	$\leq 8\text{dBm}/3\text{kHz}$	Pass	-
3.4	15.247(d)	Conducted Band Edges	$\leq 20\text{dBc}$	Pass	-
		Conducted Spurious Emission		Pass	-
3.5	15.247(d)	Radiated Band Edges and Radiated Spurious Emission	15.209(a) & 15.247(d)	Pass	Under limit 1.04 dB at 2390.000 MHz
3.6	15.207	AC Conducted Emission	15.207(a)	Pass	Under limit 23.10 dB at 23.734 MHz
3.7	15.203 & 15.247(b)	Antenna Requirement	N/A	Pass	-



1 General Description

1.1 Applicant

Sony Mobile Communications Inc.
Nya Vattentorget, 22188 Lund, Sweden

1.2 Manufacturer

Sony Mobile Communications Inc.
1-8-15 Konan, Minato-ku, Tokyo, 108-0075, Japan

1.3 Product Feature of Equipment Under Test

GSM/WCDMA/LTE, Bluetooth, DTS/UNII a/b/g/n/ac, ANT+, NFC, and GPS

Product Specification subjective to this standard	
Antenna Type / Gain	<Ant 1>: Monopole Antenna with gain -1.60 dBi <Ant 2>: Monopole Antenna with gain -4.10 dBi

EUT Information List				
IMEI	HW Version	SW Version	S/N	Performed Test Item
IMEI : 004402541707513	A	32.0.B.0.192	CB5A279FVJ	RF conducted measurement
IMEI : 004402541706515			CB5A279A2H8	Radiated Spurious Emission
IMEI : 004402541706721			CB5A279A2DY	Conducted Emission

Accessory List	
AC Adapter	Model No. : UCH20
	Type No. : AC-0061-US
	S/N : 5815W22500090 (for radiated spurious emission) 2115W15500021 (for conducted emission)
Earphone	Model No. : MDR-NC31E
	Type No. : AG-1110
USB Cable	Model No. : UCB11
	Type No. : AI-0120
	S/N : 1522A7390009100 (for radiated spurious emission) 1522A73000065C4 (for conducted emission)

Note:

1. Above EUT list and accessory list used are electrically identical per declared by manufacturer.
2. Above the accessories list are used to exercise the EUT during test.
3. For other wireless features of this EUT, test report will be issued separately.



1.4 Modification of EUT

No modifications are made to the EUT during all test items.

1.5 Testing Location

Sporton Lab is accredited to ISO 17025 by Taiwan Accreditation Foundation (TAF code : 1190) and the FCC designation No. TW1022 under the FCC 2.948(e) by Mutual Recognition Agreement (MRA) in FCC Test.

Test Site	SPORTON INTERNATIONAL INC.	
Test Site Location	No. 52, Hwa Ya 1 st Rd., Hwa Ya Technology Park, Kwei-Shan District, Tao Yuan City, Taiwan, R.O.C. TEL: +886-3-327-3456 FAX: +886-3-328-4978	
Test Site No.	Sporton Site No.	
	TH05-HY	CO05-HY

Test Site	SPORTON INTERNATIONAL INC.	
Test Site Location	No.58, Aly. 75, Ln. 564, Wenhua 3rd Rd. Guishan Dist, Taoyuan City, Taiwan (R.O.C.) TEL: +886-3-327-0868 FAX: +886-3-327-0855	
Test Site No.	Sporton Site No.	
	03CH11-HY	

Note: The test site complies with ANSI C63.4 2009 requirement.



1.6 Applicable Standards

According to the specifications of the manufacturer, the EUT must comply with the requirements of the following standards:

- ♦ FCC Part 15 Subpart C §15.247
- ♦ FCC KDB Publication No. 558074 D01 DTS Meas. Guidance v03r03
- ♦ FCC KDB 662911 D01 Multiple Transmitter Output v02r01.
- ♦ ANSI C63.10-2009

Remark:

1. All test items were verified and recorded according to the standards and without any deviation during the test.
2. FCC permits the use of the 1.5 meter table for frequency above 1GHz as an alternative in C63.10-2013 through inquiry tracking number 961829.



2 Test Configuration of Equipment Under Test

The EUT has been associated with peripherals and configuration operated in a manner tended to maximize its emission characteristics in a typical application. Frequency range investigated: conducted emission (150 kHz to 30 MHz) and radiated emission (9 kHz to the 10th harmonic of the highest fundamental frequency or to 40 GHz, whichever is lower). For radiated measurement, pre-scanned in three orthogonal panels, X, Y, Z. The worst cases (Y plane for antenna 1 and antenna 1+2; Z plane for antenna 2) were recorded in this report.

The final configuration from all the combinations and the worst-case data rates were investigated by measuring the maximum power across all the data rates and modulation modes under section 2.2.

Based on the worst configuration found above, the RF power setting is set individually to meet FCC compliance limit for the final conducted and radiated tests shown in section 2.3.

2.1 Carrier Frequency and Channel

Frequency Band	Channel	Freq. (MHz)	Channel	Freq. (MHz)
2400-2483.5 MHz	1	2412	8	2447
	2	2417	9	2452
	3	2422	10	2457
	4	2427	11	2462
	5	2432	12	2467
	6	2437	13	2472
	7	2442		



2.2 Pre-Scanned RF Power

The data rates were set in

1 Mbps for 802.11b, 6 Mbps for 802.11g, and MCS0 for 802.11n HT20 for Ant. 1 and Ant. 2;

6 Mbps for 802.11g and MCS8 for 802.11n HT20 for MIMO <Ant. 1 + 2>, due to the customer declared.

<Ant. 1>

802.11b					
Data Rate (MHz)	1M bps				
Channel	01	06	11	12	13
Frequency (MHz)	2412	2437	2462	2467	2472
Peak Power (dBm)	16.92	16.78	16.68	17.00	15.75

<Ant. 2>

802.11b					
Data Rate (MHz)	1M bps				
Channel	01	06	11	12	13
Frequency (MHz)	2412	2437	2462	2467	2472
Peak Power (dBm)	16.60	16.56	16.92	16.81	15.32

SISO <Ant. 1>

802.11g					
Data Rate (MHz)	6M bps				
Channel	01	06	11	12	13
Frequency (MHz)	2412	2437	2462	2467	2472
Peak Power (dBm)	20.32	20.26	20.14	17.71	10.71

2.4GHz 802.11n HT20					
Data Rate (MHz)	MCS0				
Channel	01	06	11	12	13
Frequency (MHz)	2412	2437	2462	2467	2472
Peak Power (dBm)	20.27	20.50	20.19	15.88	10.28



SISO <Ant. 2>

802.11g					
Data Rate (MHz)	6M bps				
Channel	01	06	11	12	13
Frequency (MHz)	2412	2437	2462	2467	2472
Peak Power (dBm)	20.40	20.34	20.35	15.52	10.07

2.4GHz 802.11n HT20					
Data Rate (MHz)	MCS0				
Channel	01	06	11	12	13
Frequency (MHz)	2412	2437	2462	2467	2472
Peak Power (dBm)	20.09	20.12	20.01	14.18	9.04

MIMO <Ant. 1+2>

802.11g					
Data Rate (MHz)	6M bps				
Channel	01	06	11	12	13
Frequency (MHz)	2412	2437	2462	2467	2472
Peak Power (dBm)	23.44	23.35	23.35	19.74	13.26

2.4GHz 802.11n HT20					
Data Rate (MHz)	MCS0				
Channel	01	06	11	12	13
Frequency (MHz)	2412	2437	2462	2467	2472
Peak Power (dBm)	23.32	23.53	23.20	17.96	12.48

Note: MIMO Ant. 1+2 is a calculated result from sum of the power MIMO Ant. 1 and MIMO Ant. 2.



2.3 Test Mode

Final test mode of conducted test items and radiated spurious emissions are considering the modulation and worse data rates from the power table described in section 2.2.

Single Antenna

Modulation	Data Rate
802.11b	1 Mbps
802.11g	6 Mbps
802.11n HT20	MCS0

MIMO Antenna

Modulation	Data Rate
802.11g	6 Mbps
802.11n HT20	MCS0

Test Cases	
AC Conducted Emission	Mode 1 : WLAN 2.4GHz Link + USB Cable (Charging from Adapter) + Earphone

2.4 Connection Diagram of Test System

<WLAN Tx Mode>

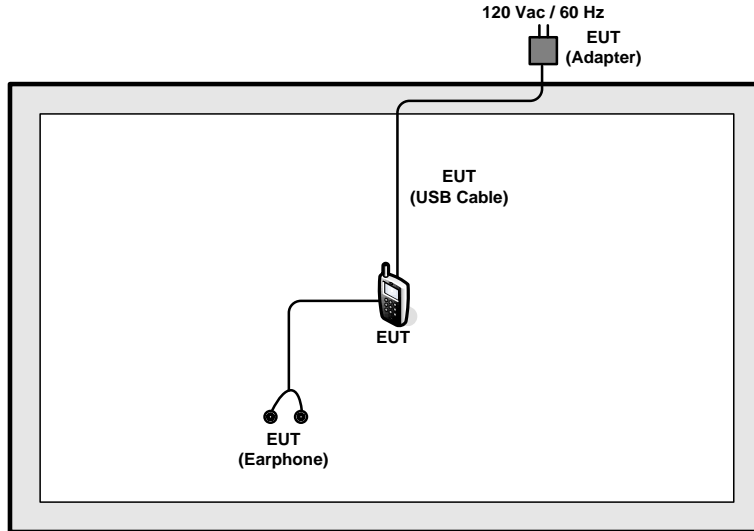

<AC Conducted Emission Mode>

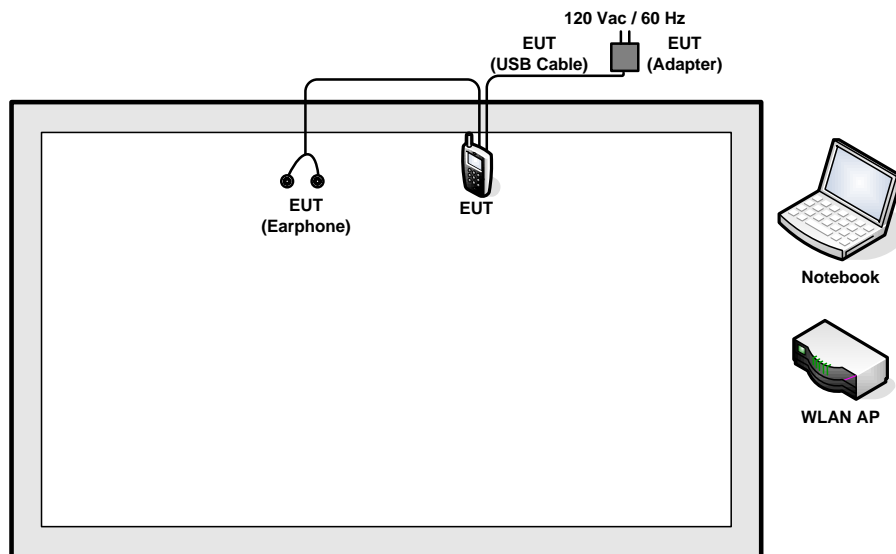

2.5 Support Unit used in test configuration and system

Item	Equipment	Trade Name	Model Name	FCC ID	Data Cable	Power Cord
1.	Bluetooth Earphone	Sony	SBH20	PY7-RD0010	Unshielded, 0.75m	N/A
2.	SD Card	SanDisk	MicroSD HC	FCC DoC	N/A	N/A



2.6 EUT Operation Test Setup

For WLAN RF test items, an engineering test program was provided and enabled to make EUT continuous transmit/receive.

2.7 Measurement Results Explanation Example

For all conducted test items:

The offset level is set in the spectrum analyzer to compensate the RF cable loss and attenuator factor between EUT conducted output port and spectrum analyzer. With the offset compensation, the spectrum analyzer reading level is exactly the EUT RF output level.

Example:

The spectrum analyzer offset is derived from RF cable loss and attenuator factor.

Offset = RF cable loss + attenuator factor.

Following shows an offset computation example with cable loss 4.2 dB and 10dB attenuator.

$$\begin{aligned} \text{Offset(dB)} &= \text{RF cable loss(dB)} + \text{attenuator factor(dB)} \\ &= 4.2 + 10 = 14.2 \text{ (dB)} \end{aligned}$$

3 Test Result

3.1 6dB Bandwidth Measurement

3.1.1 Limit of 6dB Bandwidth

The minimum 6 dB bandwidth shall be at least 500 kHz.

3.1.2 Measuring Instruments

The measuring equipment is listed in the section 4 of this test report.

3.1.3 Test Procedures

1. The testing follows FCC KDB Publication No. 558074 DTS D01 Meas. Guidance v03r03.
2. The RF output of EUT was connected to the spectrum analyzer by RF cable and attenuator. The path loss was compensated to the results for each measurement.
3. Set to the maximum power setting and enable the EUT transmit continuously.
4. Make the measurement with the spectrum analyzer's resolution bandwidth (RBW) = 100 kHz. Set the Video bandwidth (VBW) = 300 kHz. In order to make an accurate measurement. The 6 dB bandwidth must be greater than 500 kHz.
5. Measure and record the results in the test report.

3.1.4 Test Setup





3.1.5 Test Result of 6dB Occupied Bandwidth

Please refer to Appendix A of this test report.

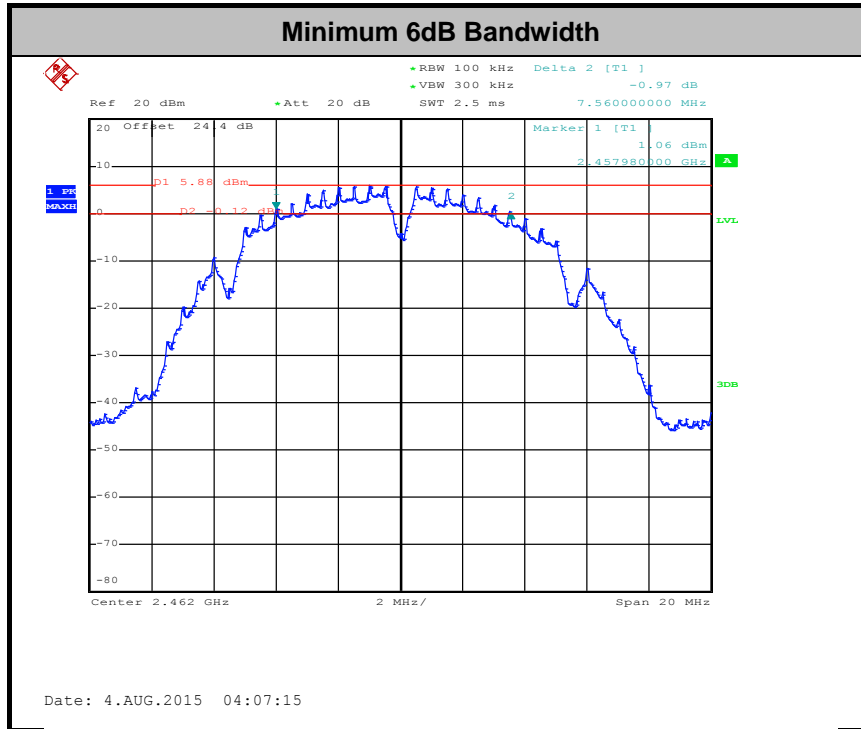

3.2 Peak Output Power Measurement

3.2.1 Limit of Peak Output Power

For systems using digital modulation in the 2400-2483.5MHz, the limit for peak output power is 30dBm. If transmitting antenna with directional gain greater than 6dBi is used, the peak output power from the intentional radiator shall be reduced below the above stated value by the amount in dB that the directional gain of the antenna exceeds 6 dBi. In case of point-to-point operation, the limit has to be reduced by 1dB for every 3dB that the directional gain of the antenna exceeds 6dBi.

3.2.2 Measuring Instruments

The measuring equipment is listed in the section 4 of this test report.

3.2.3 Test Procedures

1. The testing follows the Measurement Procedure of FCC KDB No. 558074 DTS D01 Meas. Guidance v03r03.
2. The RF output of EUT was connected to the power meter by RF cable and attenuator. The path loss was compensated to the results for each measurement.
3. Set to the maximum power setting and enable the EUT transmit continuously.
4. Measure the conducted output power and record the results in the test report.
5. For MIMO mode, calculation method follows FCC KDB 662911 D01 Multiple Transmitter Output v02r01.

3.2.4 Test Setup

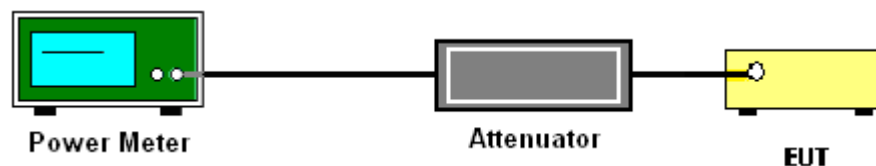

3.2.5 Test Result of Peak Output Power

Please refer to Appendix A of this test report.

3.2.6 Test Result of Average output Power (Reporting Only)

Please refer to Appendix A of this test report.



3.3 Power Spectral Density Measurement

3.3.1 Limit of Power Spectral Density

The peak power spectral density shall not be greater than 8dBm in any 3kHz band at any time interval of continuous transmission.

3.3.2 Measuring Instruments

The measuring equipment is listed in the section 4 of this test report.

3.3.3 Test Procedures

1. The testing follows Measurement Procedure 10.2 Method PKPSD of FCC KDB Publication No. 558074 D01 DTS Meas. Guidance v03r03
2. The RF output of EUT was connected to the spectrum analyzer by RF cable and attenuator. The path loss was compensated to the results for each measurement.
3. Set to the maximum power setting and enable the EUT transmit continuously.
4. Make the measurement with the spectrum analyzer's resolution bandwidth (RBW) = 3 kHz. Video bandwidth VBW = 10 kHz In order to make an accurate measurement, set the span to 1.5 times DTS Channel Bandwidth. (6dB BW)
5. Detector = peak, Sweep time = auto couple, Trace mode = max hold, Allow trace to fully stabilize. Use the peak marker function to determine the maximum power level.
6. Measure and record the results in the test report.
7. For MIMO mode, calculation method follows FCC KDB 662911 D01 Multiple Transmitter Output v02r01.

If measurements performed using method (2) plus $10 \log(N)$ exceeds the emission limit, the test should choose method (1) before declaring that the device fails the emission limit.

Method (1): Measure and sum the spectra across the outputs.

The total final Power Spectral Density is from a device with 2 transmitter outputs. The spectrum measurements of the individual outputs are all performed with the same span and number of points, the spectrum value in the first spectral bin of output 1 is summed with that in the first spectral bin of output 2 to obtain the value for the first frequency bin of the summed spectrum.

Method (2): Measure and add $10 \log(N)$ dB, where N is the number of outputs. (N=2)

3.3.4 Test Setup

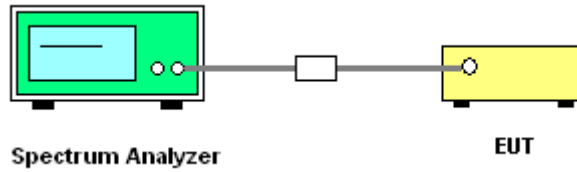

3.3.5 Test Result of Power Spectral Density

Please refer to Appendix A of this test report.

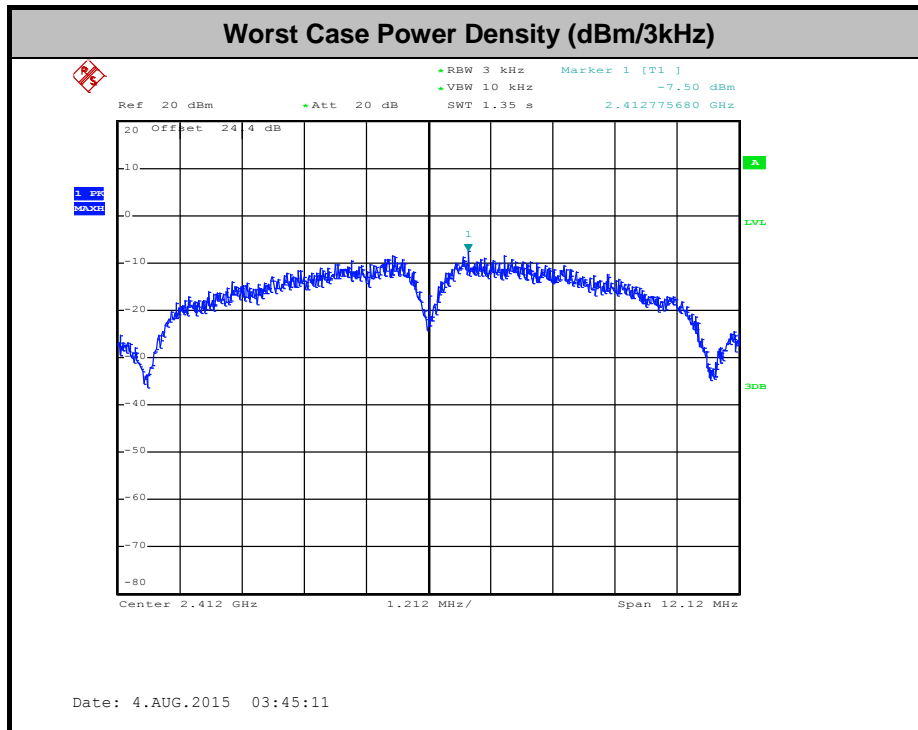

3.4 Conducted Band Edges and Spurious Emission Measurement

3.4.1 Limit of Conducted Band Edges and Spurious Emission Measurement

In any 100 kHz bandwidth outside of the authorized frequency band, the emissions which fall in the non-restricted bands shall be attenuated at least 20 dB / 30dB relative to the maximum PSD level in 100 kHz by RF conducted measurement and radiated emissions which fall in the restricted bands, as defined in Section 15.205(a), must also comply with the radiated emission limits specified in Section 15.209(a).

3.4.2 Measuring Instruments

The measuring equipment is listed in the section 4 of this test report.

3.4.3 Test Procedures

1. The testing follows FCC KDB Publication No. 558074 D01 DTS Meas. Guidance v03r03.
2. The RF output of EUT was connected to the spectrum analyzer by RF cable and attenuator. The path loss was compensated to the results for each measurement.
3. Set to the maximum power setting and enable the EUT transmit continuously.
4. Set RBW = 100 kHz, VBW=300 kHz, Peak Detector. Unwanted Emissions measured in any 100 kHz bandwidth outside of the authorized frequency band shall be attenuated by at least 20 dB relative to the maximum in-band peak PSD level in 100 kHz when maximum peak conducted output power procedure is used. If the transmitter complies with the conducted power limits based on the use of RMS averaging over a time interval, the attenuation required under this paragraph shall be 30 dB instead of 20 dB per 15.247(d).
5. Measure and record the results in the test report.
6. The RF fundamental frequency should be excluded against the limit line in the operating frequency band.

3.4.4 Test Setup

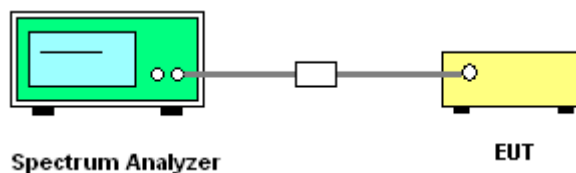



3.4.5 Test Result of Conducted Band Edges and Spurious Emission

Number of TX = 1, Ant. 1 (Measured)

Number of TX	1	Ant. :	1
Test Mode :	802.11b	Temperature :	22~23°C
Test Band :	2.4GHz Low	Relative Humidity :	52~53%
Test Channel :	01	Test Engineer :	Osolemio Chang

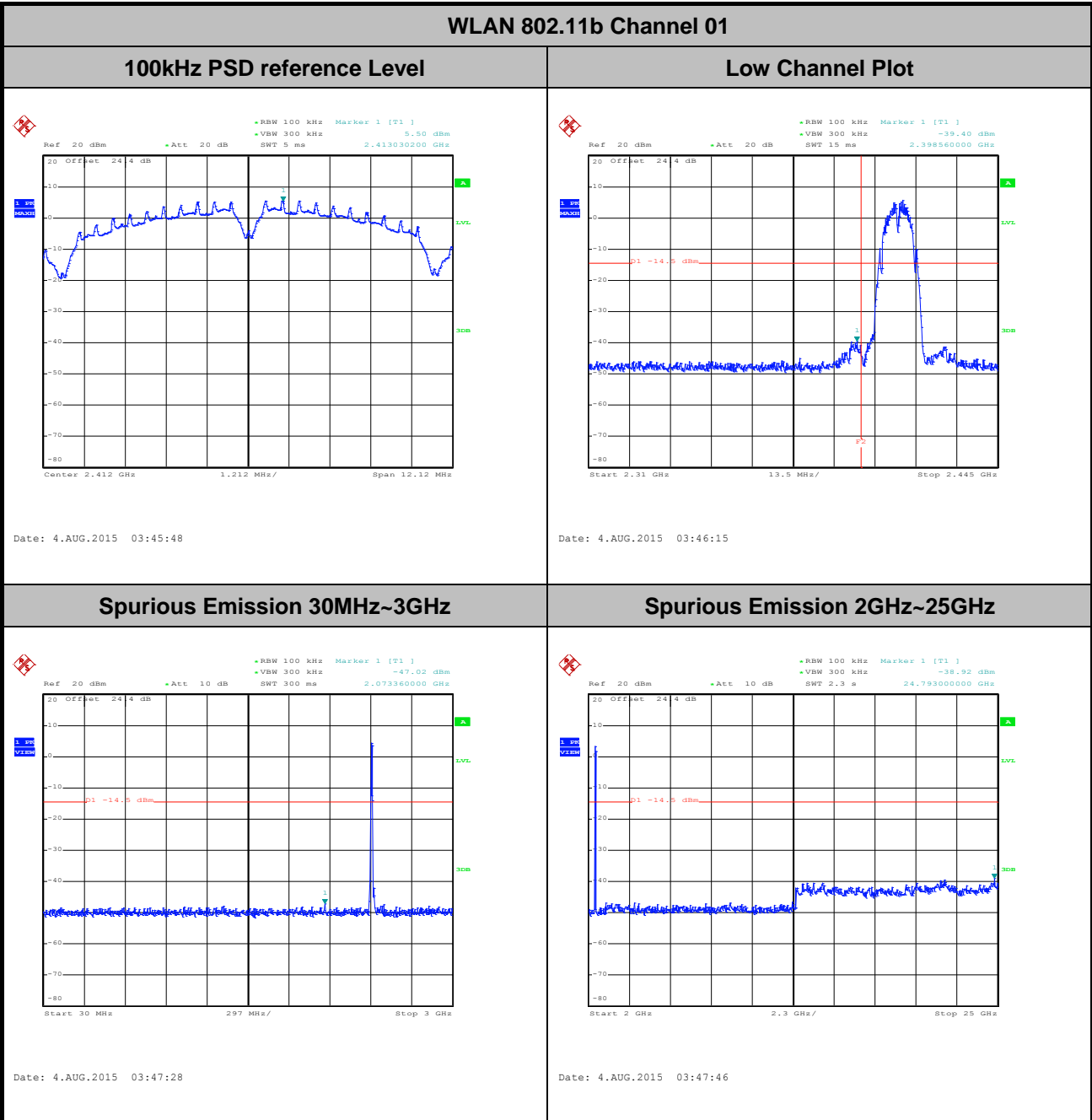



Number of TX :	1	Ant. :	1
Test Mode :	802.11b	Temperature :	22~23°C
Test Band :	2.4GHz Mid	Relative Humidity :	52~53%
Test Channel :	06	Test Engineer :	Osolemio Chang

WLAN 802.11b Channel 06

100kHz PSD reference Level

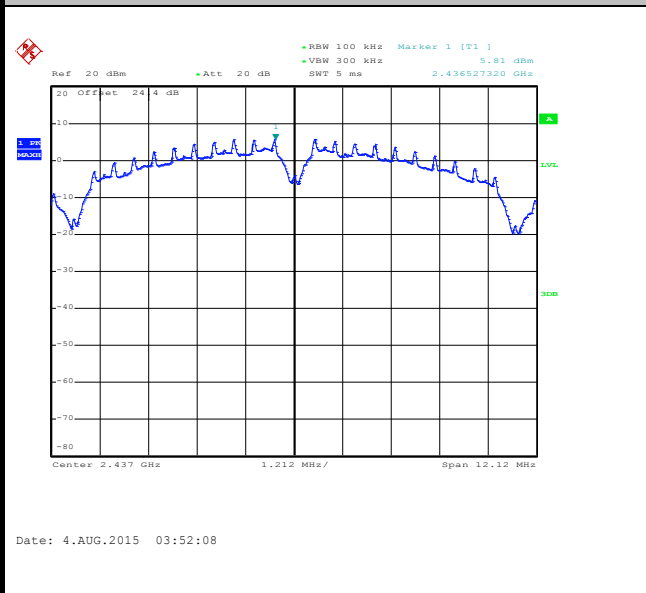

Spurious Emission 30MHz~3GHz

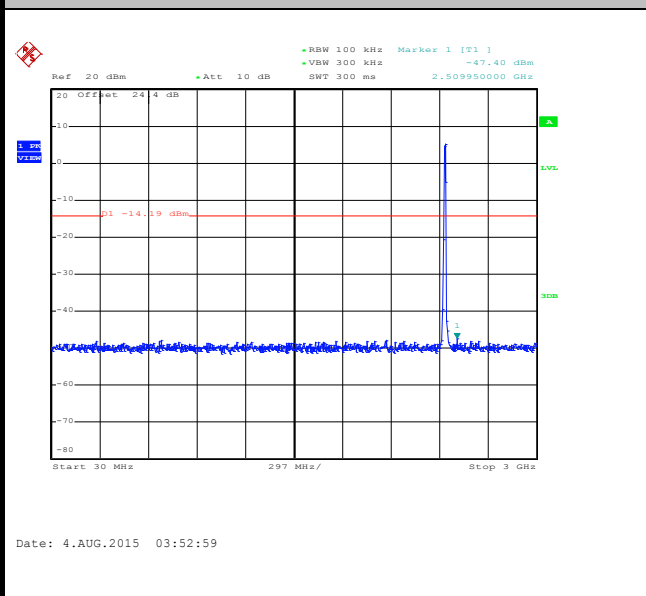

Spurious Emission 2GHz~25GHz

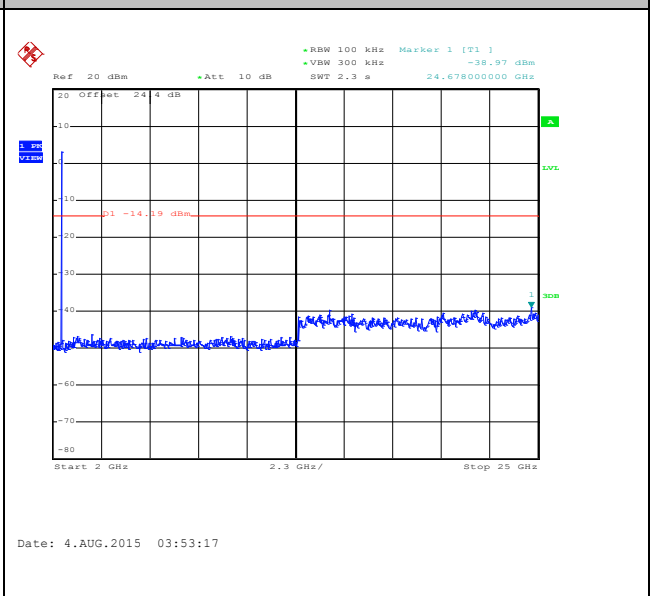



Number of TX :	1	Ant. :	1
Test Mode :	802.11b	Temperature :	22~23°C
Test Band :	2.4GHz High	Relative Humidity :	52~53%
Test Channel :	11	Test Engineer :	Osolemio Chang

WLAN 802.11b Channel 11

100kHz PSD reference Level

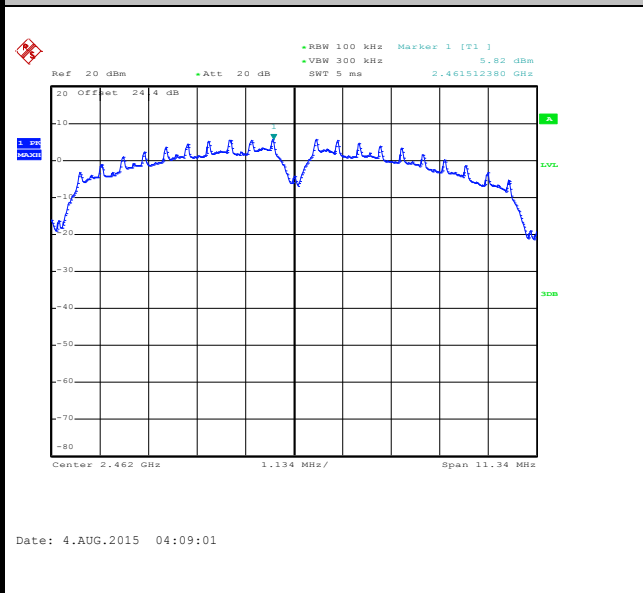

High Channel Plot

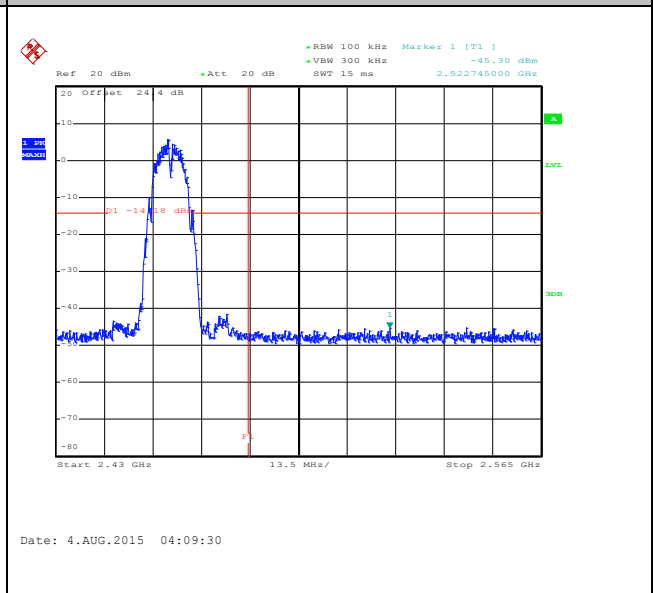

Spurious Emission 30MHz~3GHz

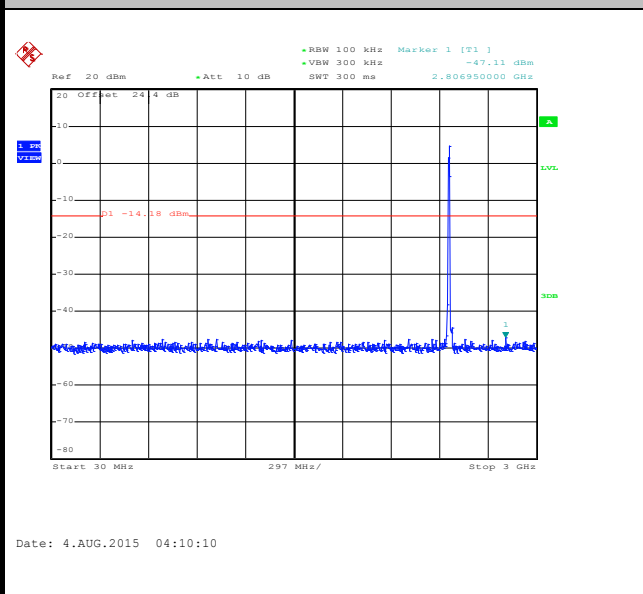

Spurious Emission 2GHz~25GHz

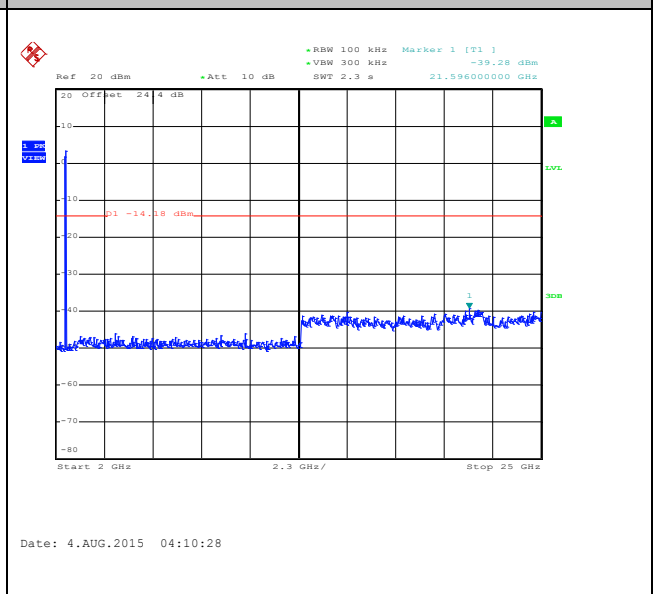



Number of TX :	1	Ant. :	1
Test Mode :	802.11b	Temperature :	22~23°C
Test Band :	2.4GHz High	Relative Humidity :	52~53%
Test Channel :	12	Test Engineer :	Osolemio Chang

WLAN 802.11b Channel 12

100kHz PSD reference Level

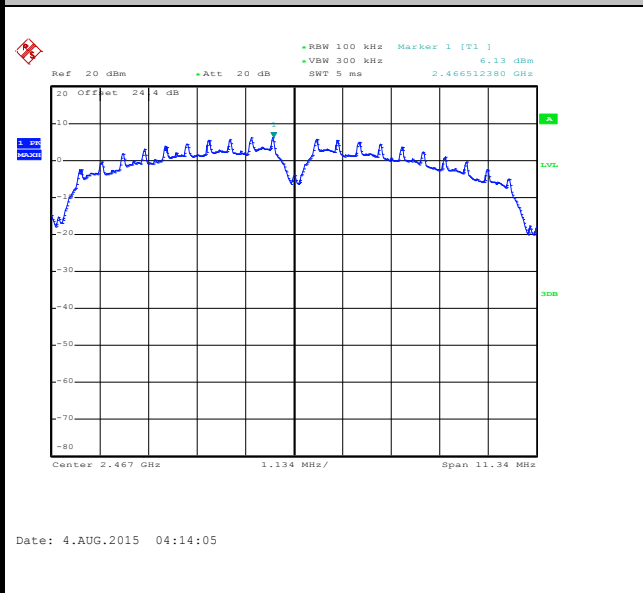

High Channel Plot

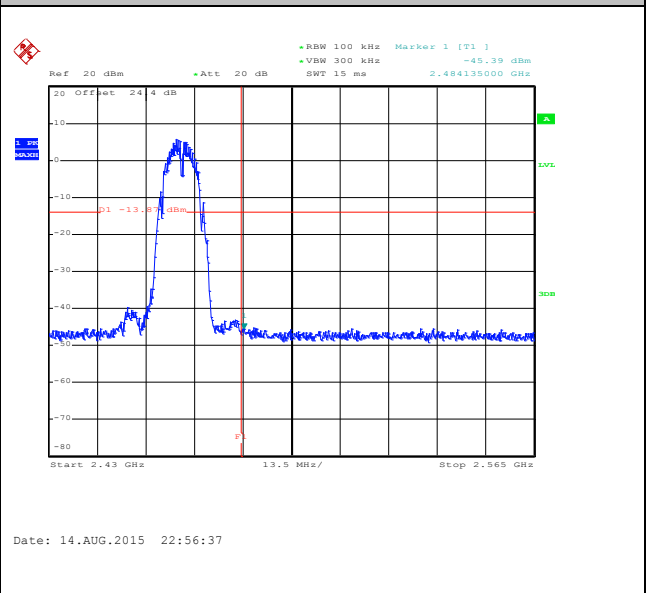

Spurious Emission 30MHz~3GHz

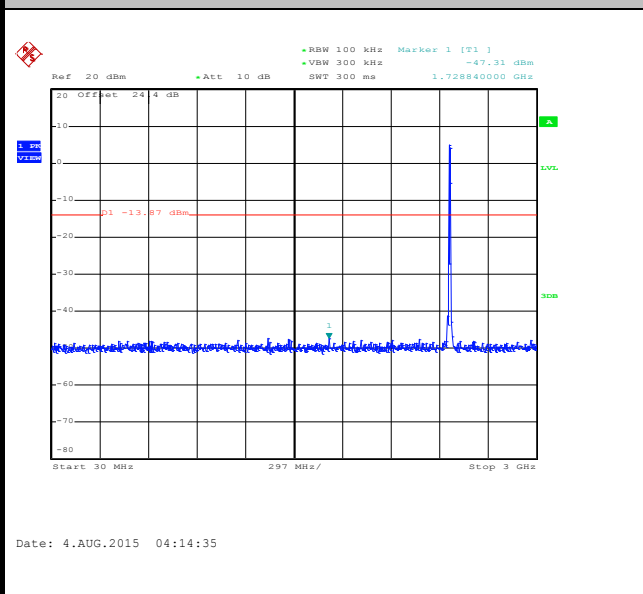

Spurious Emission 2GHz~25GHz

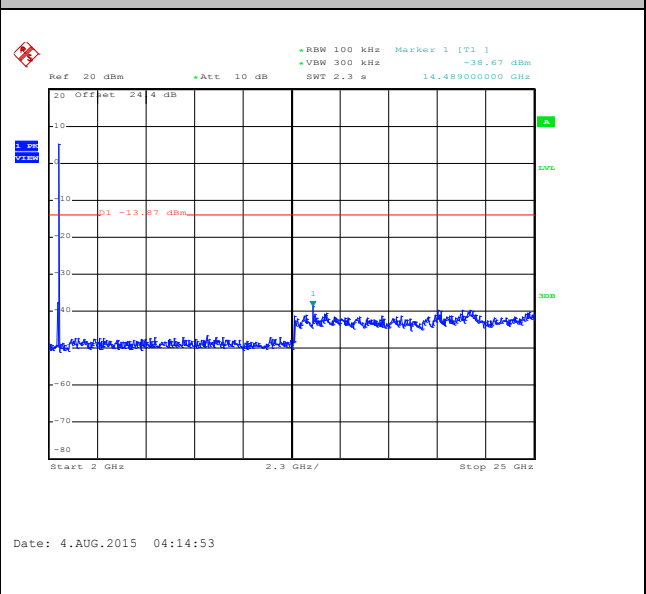



Number of TX :	1	Ant. :	1
Test Mode :	802.11b	Temperature :	22~23°C
Test Band :	2.4GHz High	Relative Humidity :	52~53%
Test Channel :	13	Test Engineer :	Osolemio Chang

WLAN 802.11b Channel 13

100kHz PSD reference Level

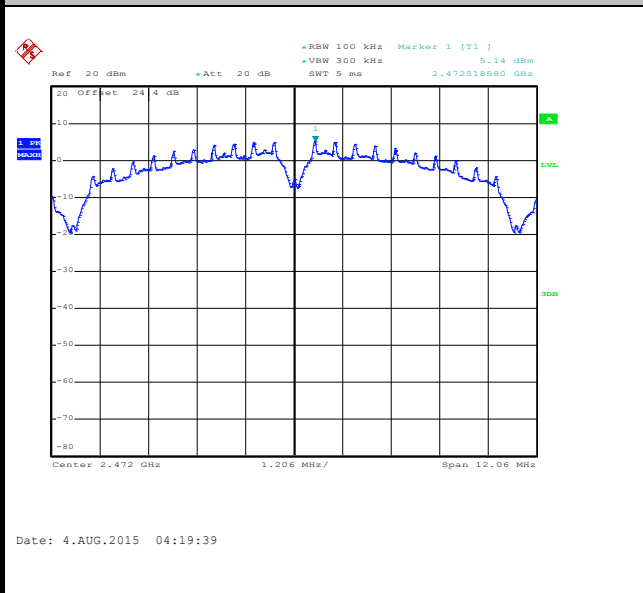

High Channel Plot

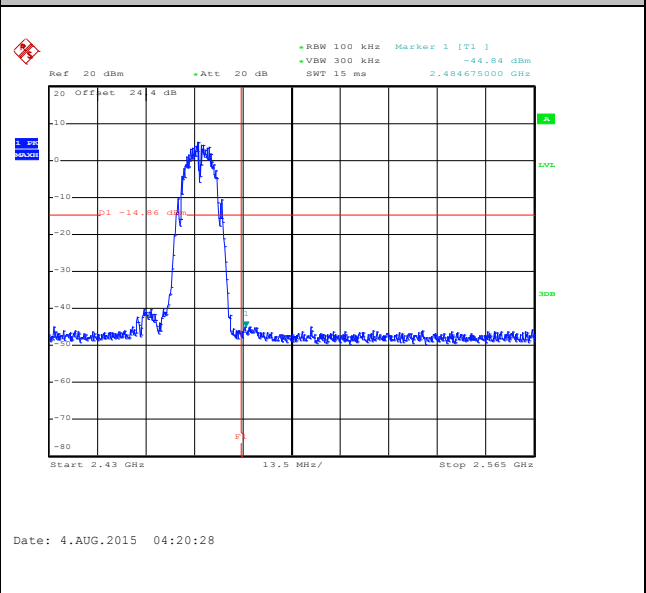

Spurious Emission 30MHz~3GHz

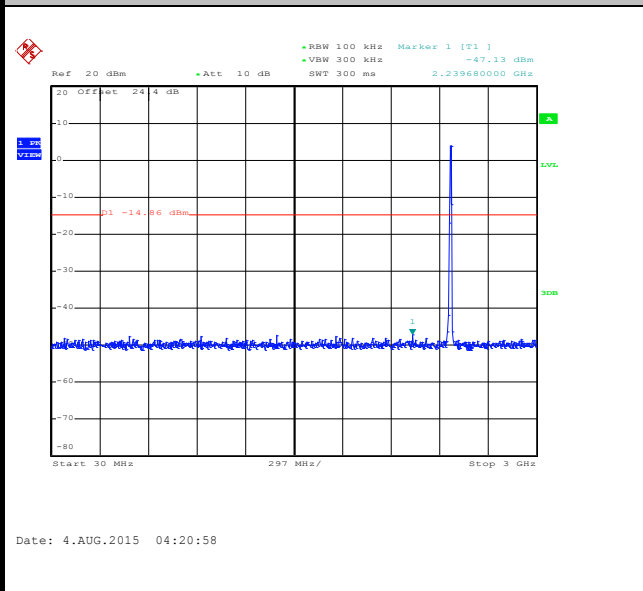

Spurious Emission 2GHz~25GHz

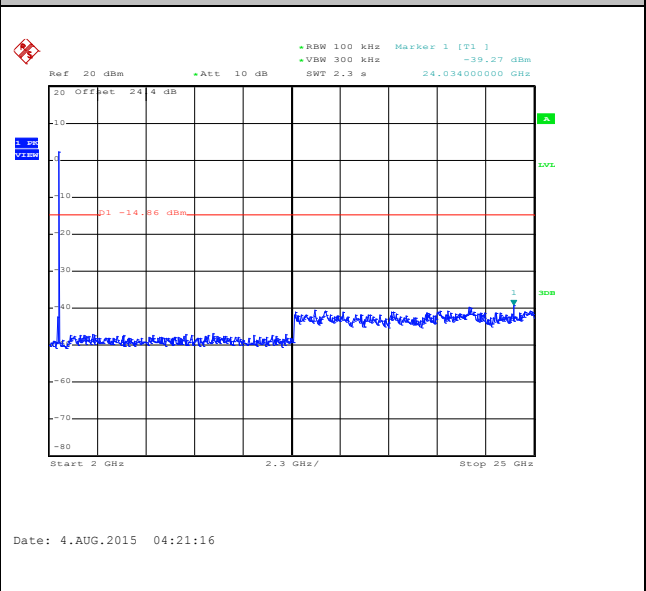



Number of TX = 1, Ant. 2 (Measured)

Number of TX	1	Ant. :	2
Test Mode :	802.11b	Temperature :	22~23°C
Test Band :	2.4GHz Low	Relative Humidity :	52~53%
Test Channel :	01	Test Engineer :	Osolemio Chang

WLAN 802.11b Channel 01

100kHz PSD reference Level

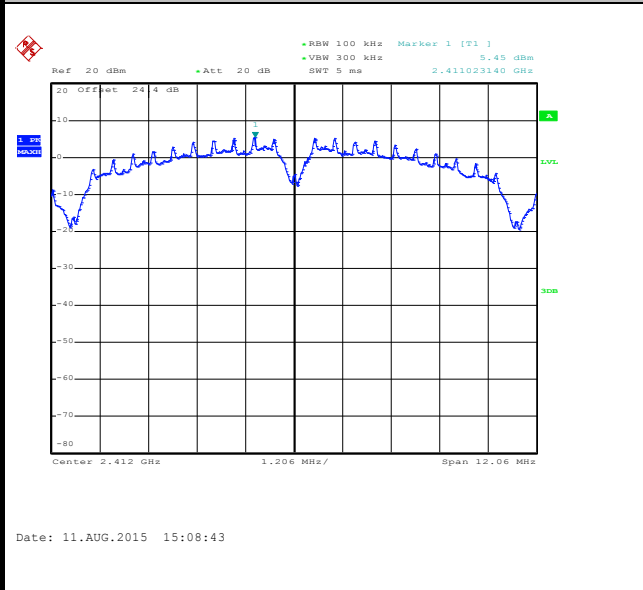

Low Channel Plot

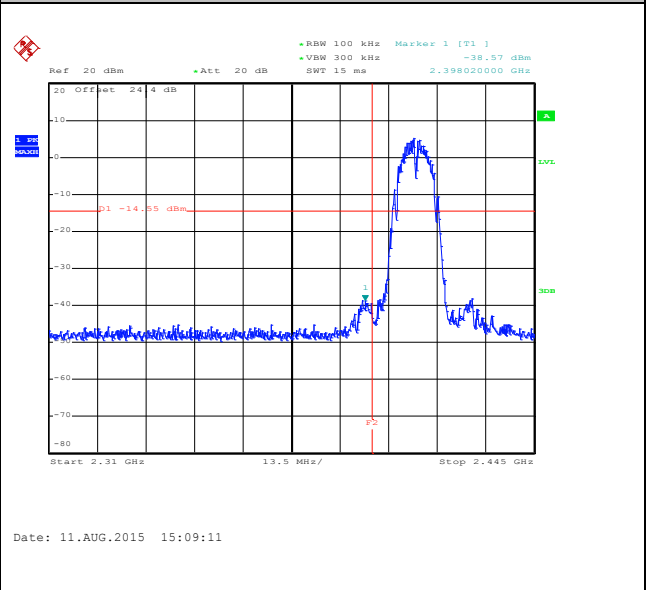

Spurious Emission 30MHz~3GHz

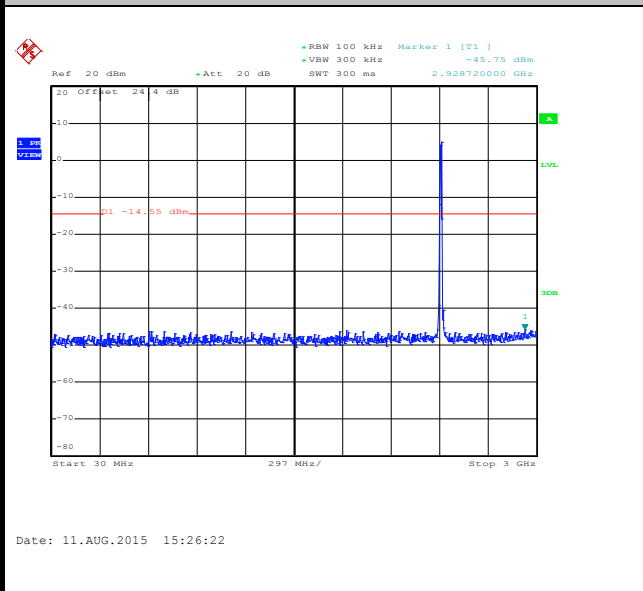

Spurious Emission 2GHz~25GHz

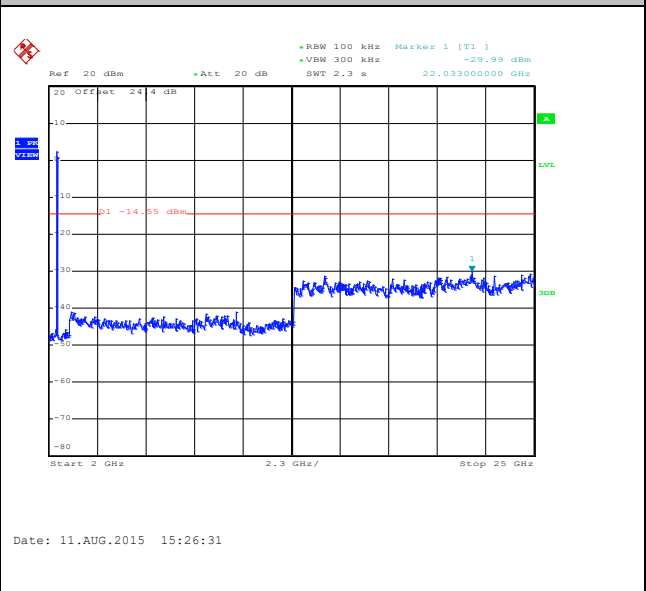



Number of TX	1	Ant. :	2
Test Mode :	802.11b	Temperature :	22~23°C
Test Band :	2.4GHz Mid	Relative Humidity :	52~53%
Test Channel :	06	Test Engineer :	Osolemio Chang

WLAN 802.11b Channel 06

100kHz PSD reference Level

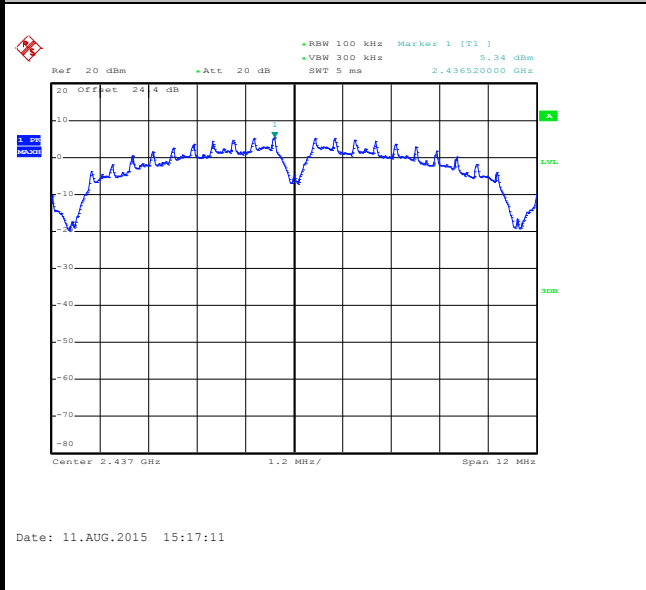

Spurious Emission 30MHz~3GHz

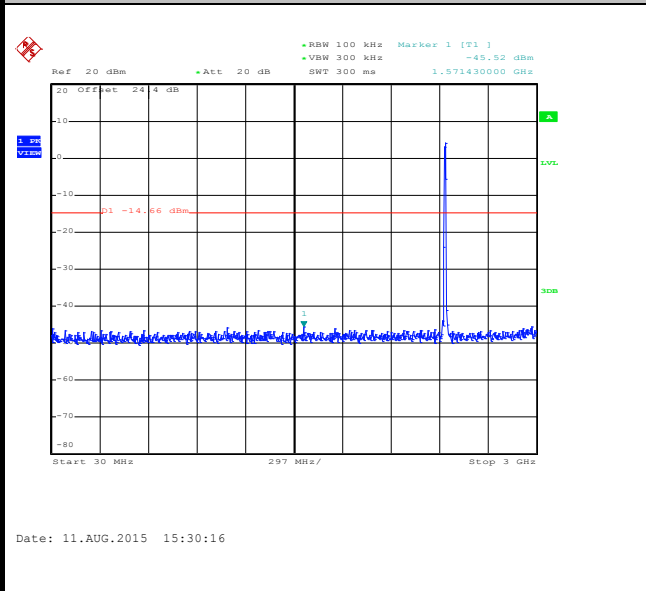

Spurious Emission 2GHz~25GHz

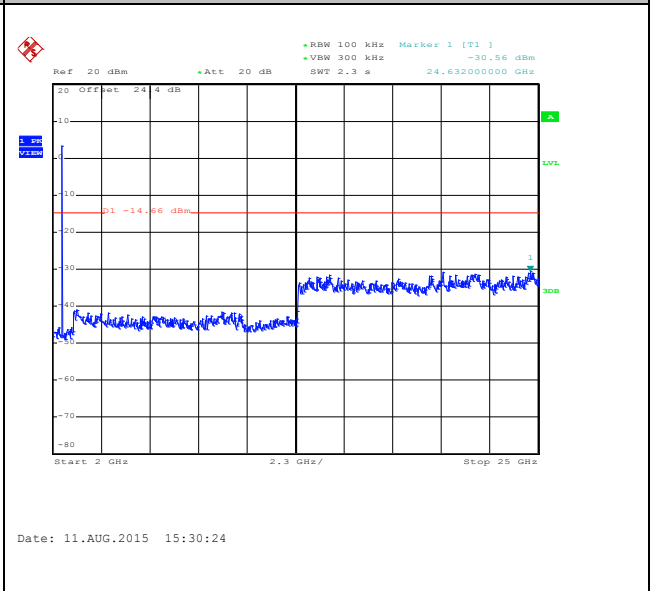



Number of TX	1	Ant. :	2
Test Mode :	802.11b	Temperature :	22~23°C
Test Band :	2.4GHz High	Relative Humidity :	52~53%
Test Channel :	11	Test Engineer :	Osolemio Chang

WLAN 802.11b Channel 11

100kHz PSD reference Level

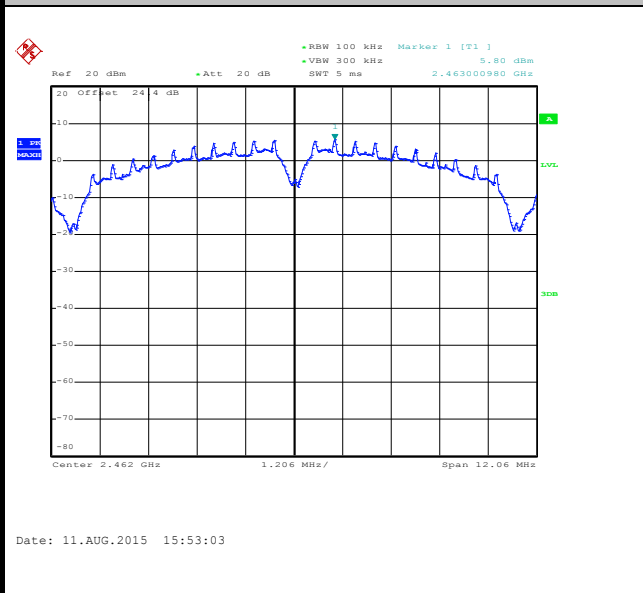

High Channel Plot

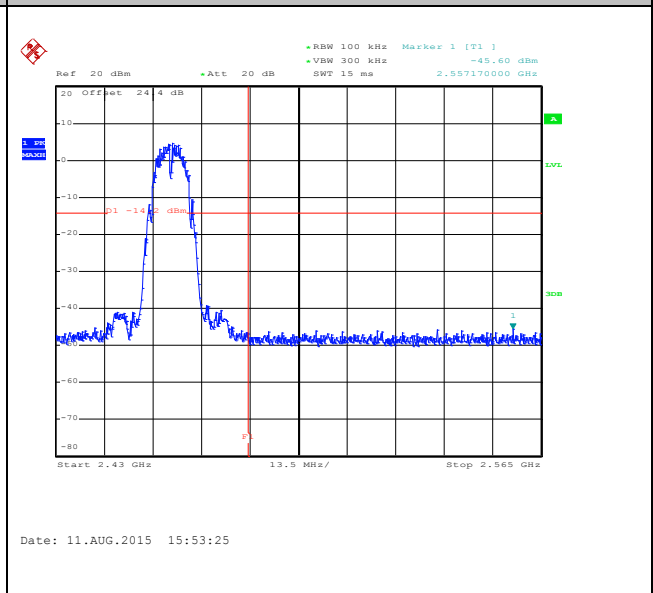

Spurious Emission 30MHz~3GHz

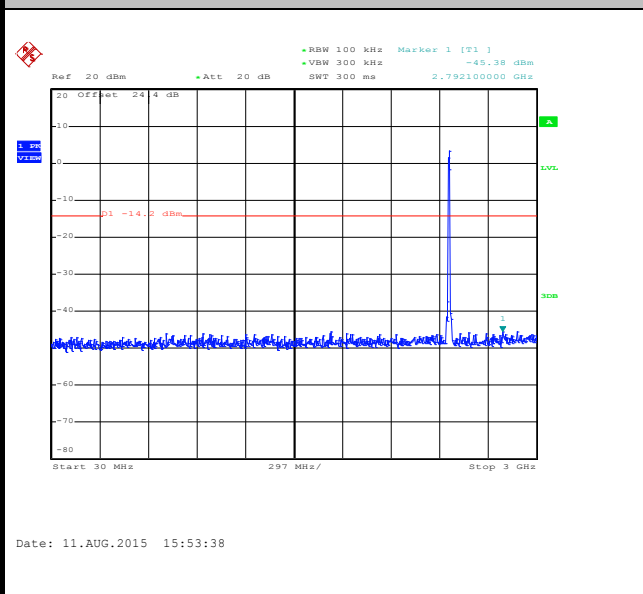

Spurious Emission 2GHz~25GHz

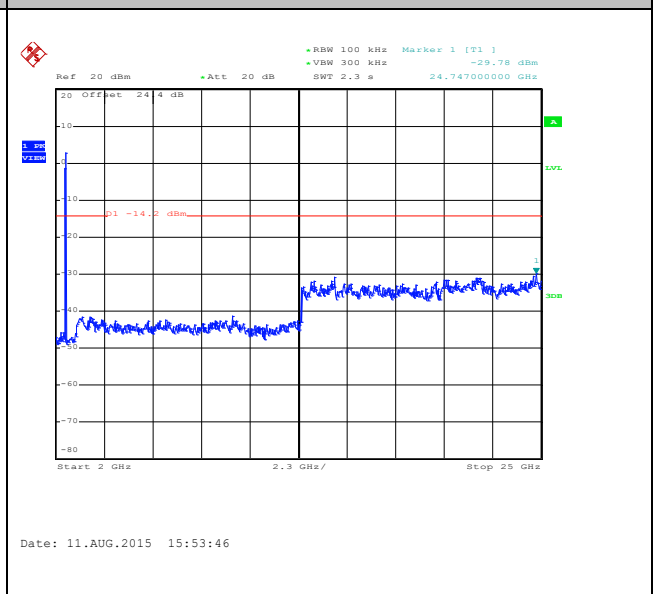



Number of TX	1	Ant. :	2
Test Mode :	802.11b	Temperature :	22~23°C
Test Band :	2.4GHz High	Relative Humidity :	52~53%
Test Channel :	12	Test Engineer :	Osolemio Chang

WLAN 802.11b Channel 12

100kHz PSD reference Level

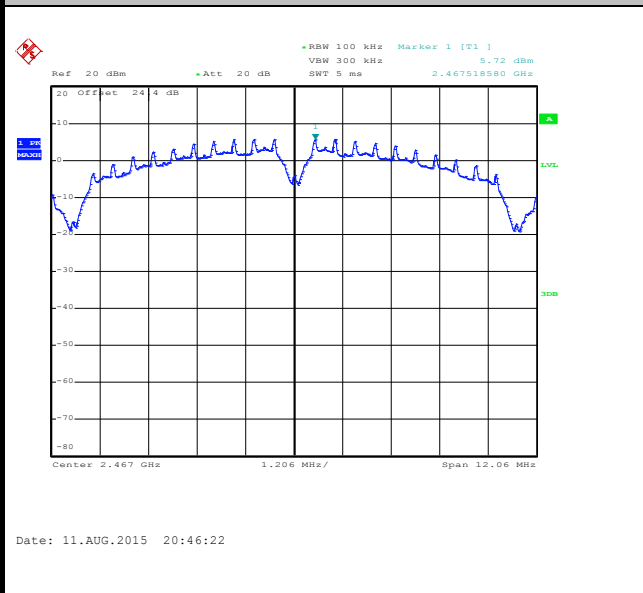

High Channel Plot

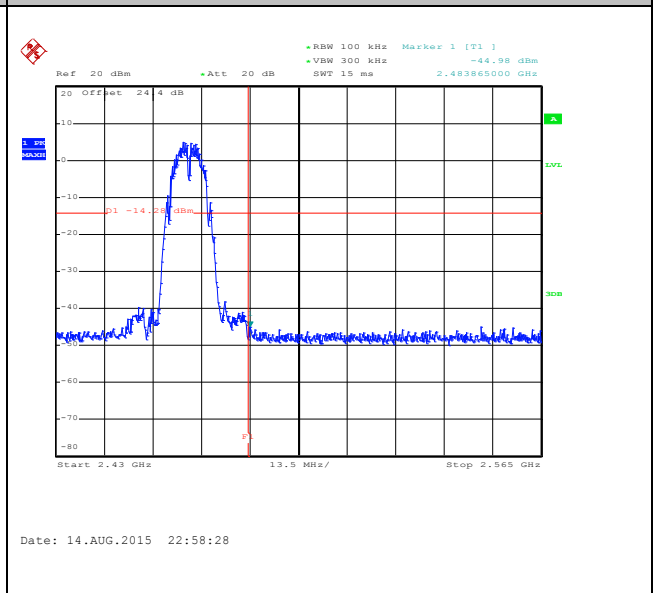

Spurious Emission 30MHz~3GHz

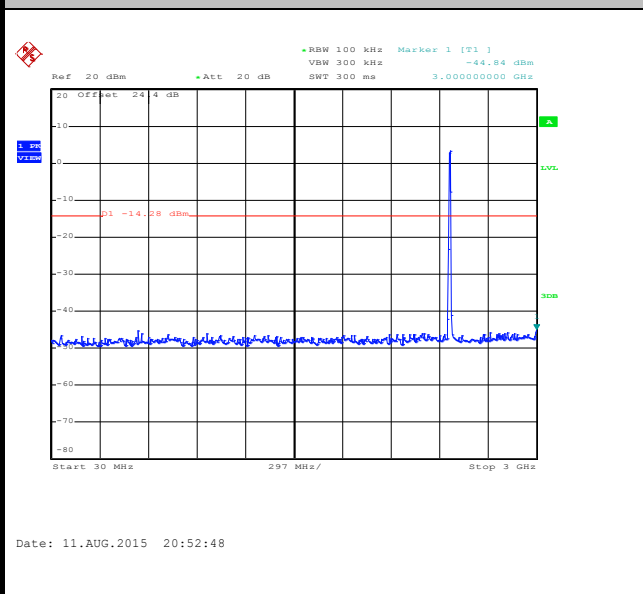

Spurious Emission 2GHz~25GHz

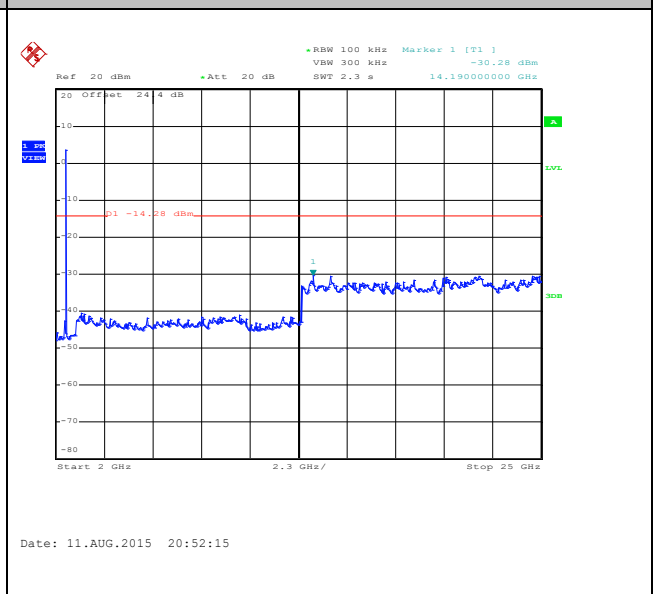



Number of TX	1	Ant. :	2
Test Mode :	802.11b	Temperature :	22~23°C
Test Band :	2.4GHz High	Relative Humidity :	52~53%
Test Channel :	13	Test Engineer :	Osolemio Chang

WLAN 802.11b Channel 13

100kHz PSD reference Level

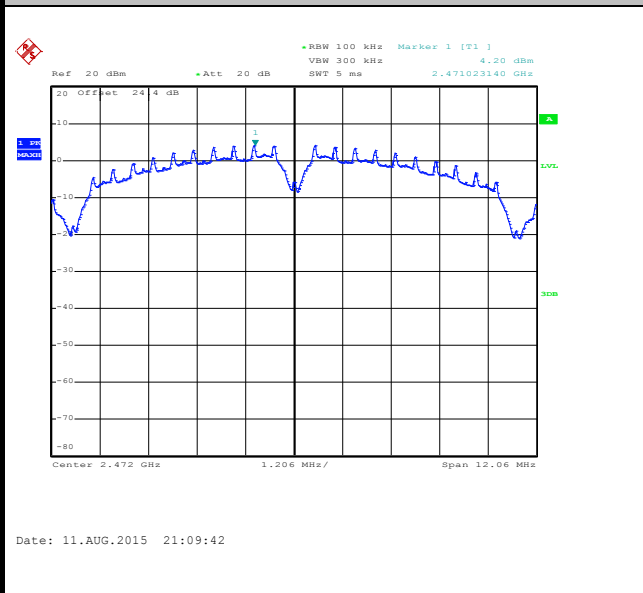

High Channel Plot

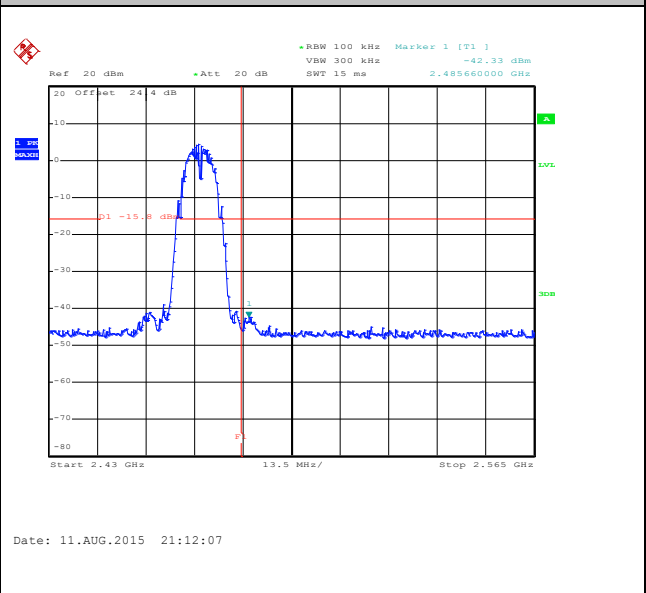

Spurious Emission 30MHz~3GHz

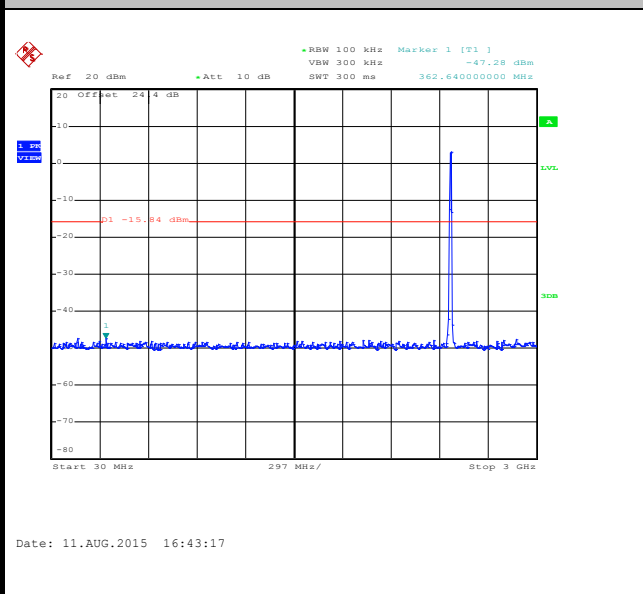

Spurious Emission 2GHz~25GHz

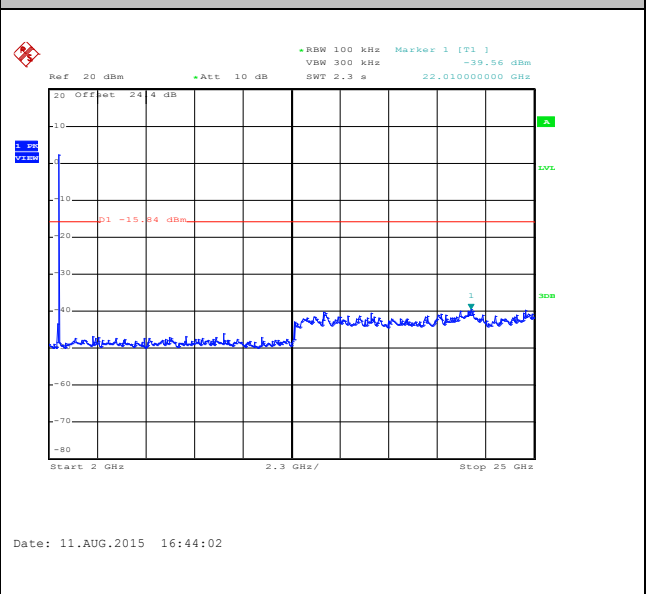



Number of TX = 2, Ant. 1(Measured)

Number of TX :	2	Ant. :	1
Test Mode :	802.11g	Temperature :	22~23°C
Test Band :	2.4GHz Low	Relative Humidity :	52~53%
Test Channel :	01	Test Engineer :	Osolemio Chang

WLAN 802.11g Channel 01

100kHz PSD reference Level

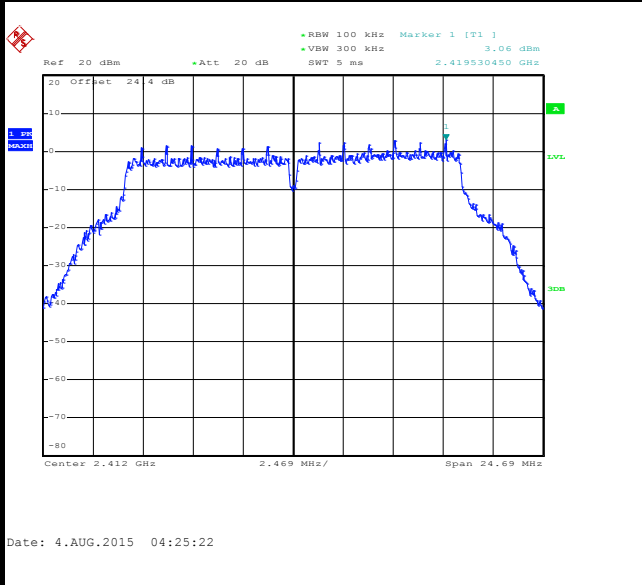

Low Channel Plot

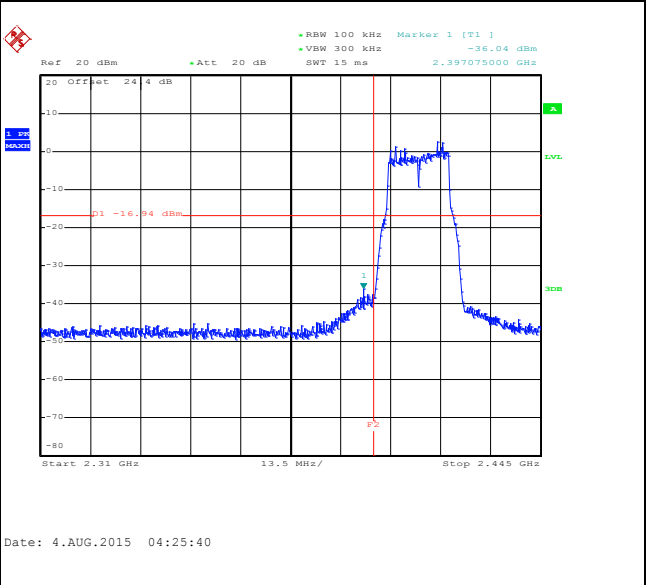

Spurious Emission 30MHz~3GHz

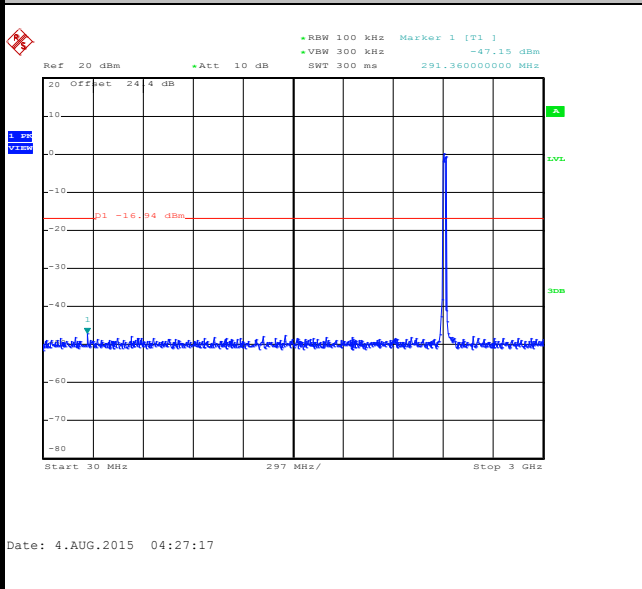

Spurious Emission 2GHz~25GHz

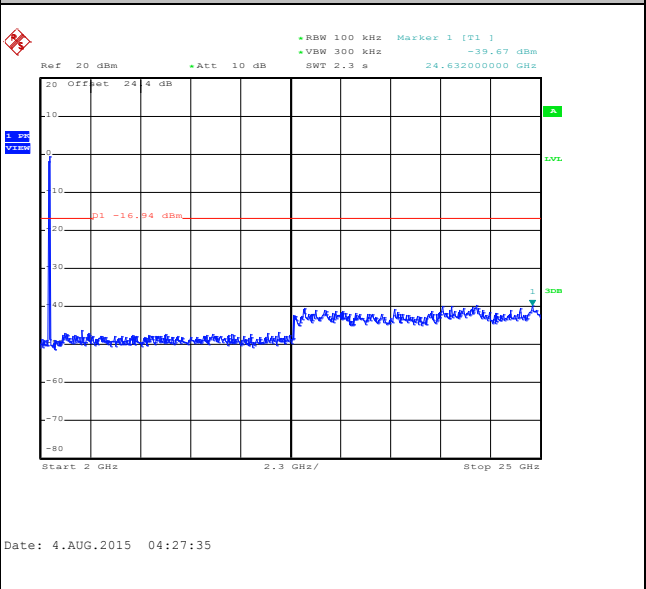



Number of TX :	2	Ant. :	1
Test Mode :	802.11g	Temperature :	22~23°C
Test Band :	2.4GHz Mid	Relative Humidity :	52~53%
Test Channel :	06	Test Engineer :	Osolemio Chang

WLAN 802.11g Channel 06

100kHz PSD reference Level

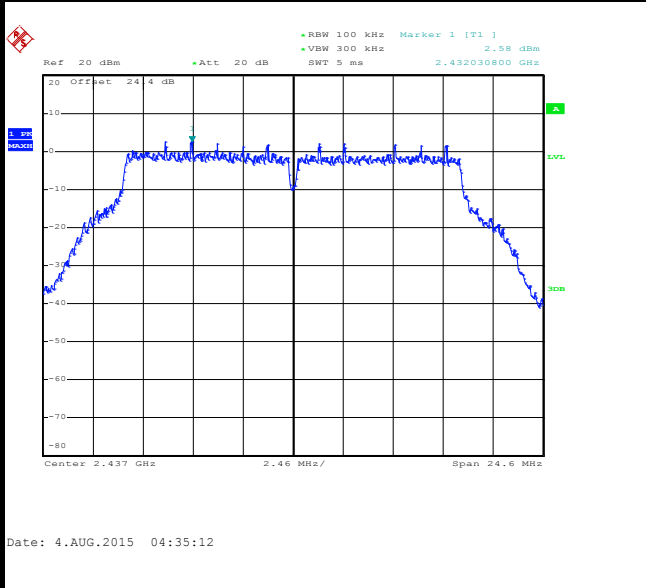

Spurious Emission 30MHz~3GHz

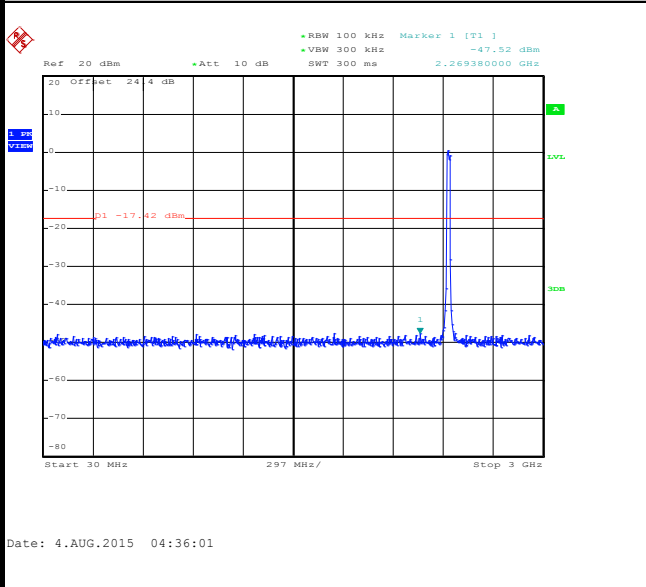

Spurious Emission 2GHz~25GHz

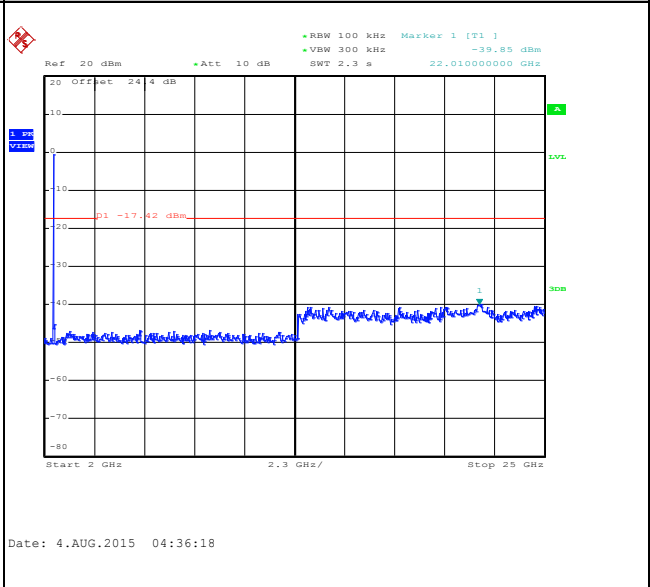



Number of TX :	2	Ant. :	1
Test Mode :	802.11g	Temperature :	22~23°C
Test Band :	2.4GHz High	Relative Humidity :	52~53%
Test Channel :	11	Test Engineer :	Osolemio Chang

WLAN 802.11g Channel 11

100kHz PSD reference Level

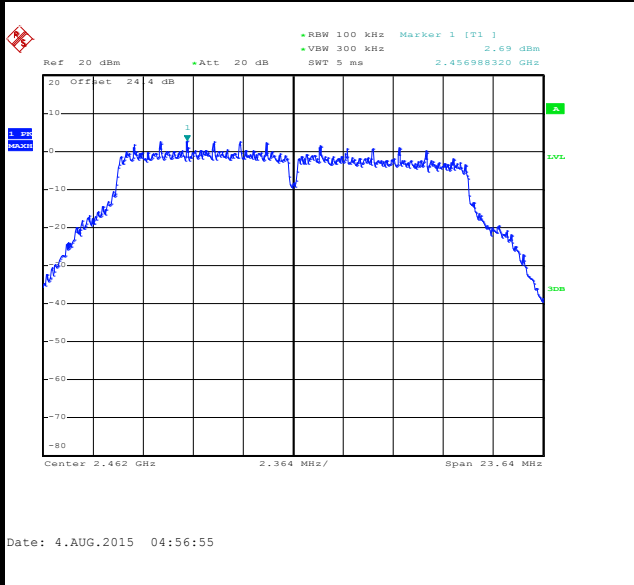

High Channel Plot

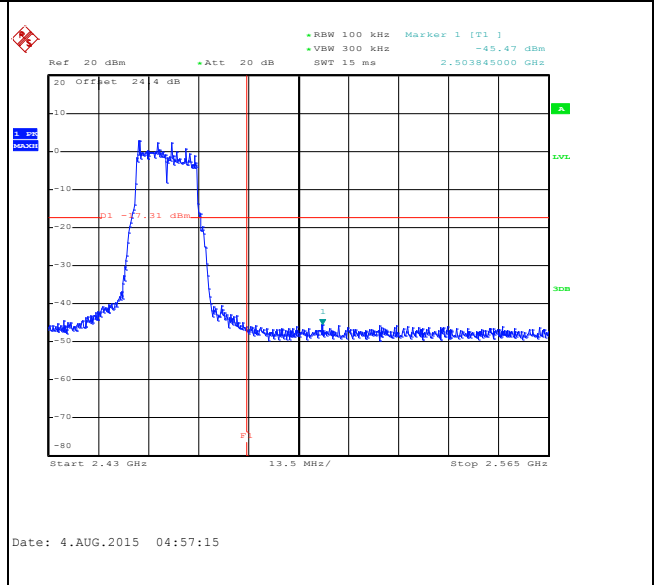

Spurious Emission 30MHz~3GHz

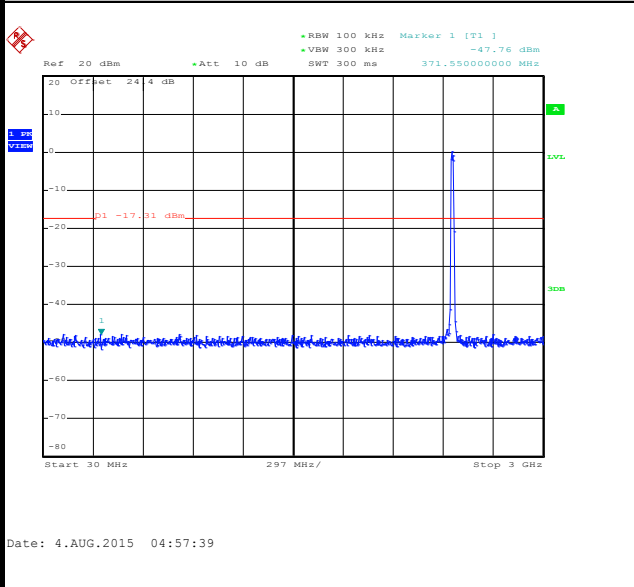

Spurious Emission 2GHz~25GHz

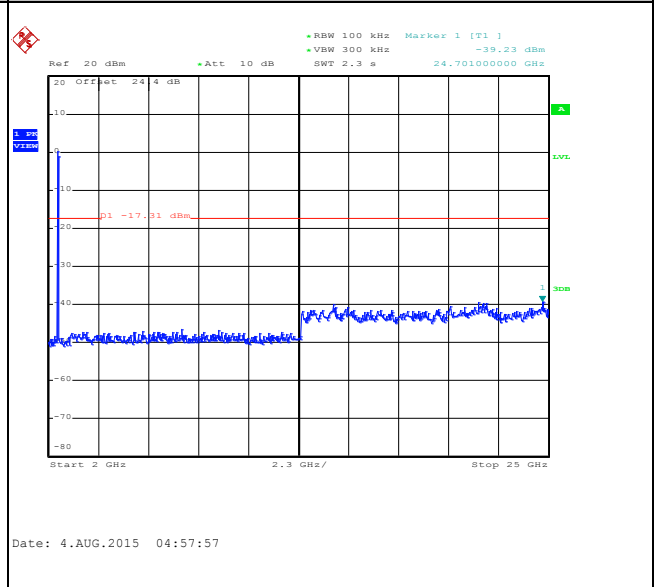



Number of TX :	2	Ant. :	1
Test Mode :	802.11g	Temperature :	22~23°C
Test Band :	2.4GHz High	Relative Humidity :	52~53%
Test Channel :	12	Test Engineer :	Osolemio Chang

WLAN 802.11g Channel 12

100kHz PSD reference Level

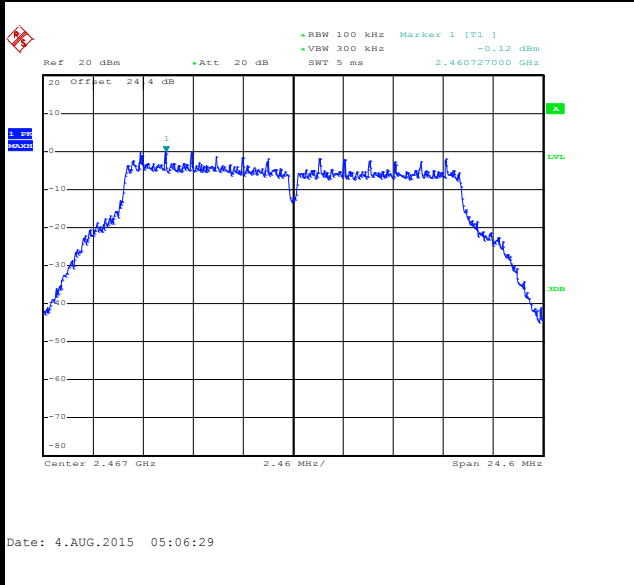

High Channel Plot

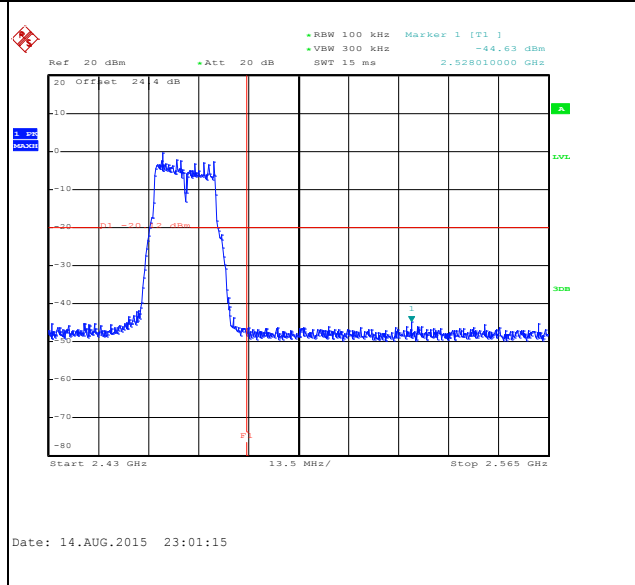

Spurious Emission 30MHz~3GHz

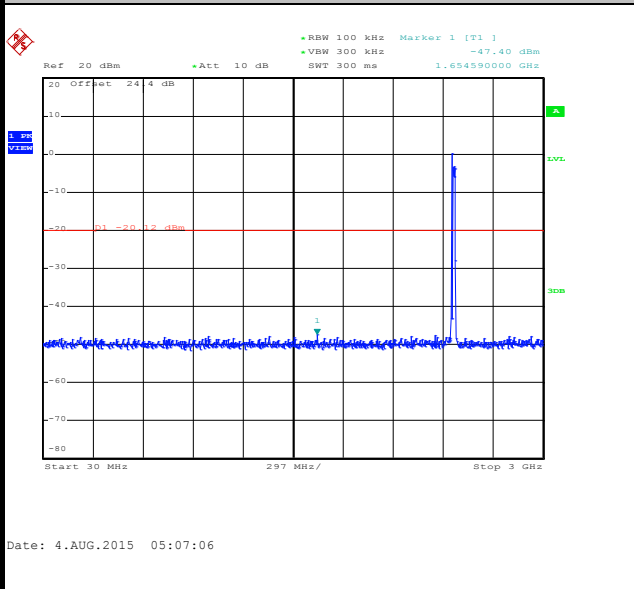

Spurious Emission 2GHz~25GHz

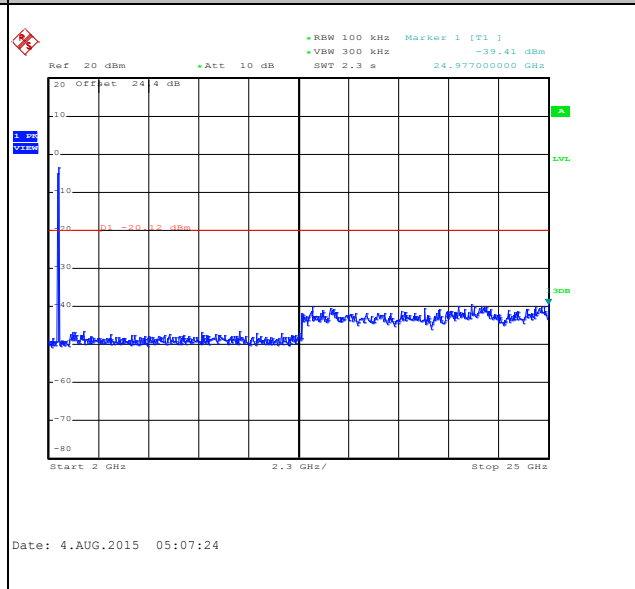



Number of TX :	2	Ant. :	1
Test Mode :	802.11g	Temperature :	22~23°C
Test Band :	2.4GHz High	Relative Humidity :	52~53%
Test Channel :	13	Test Engineer :	Osolemio Chang

WLAN 802.11g Channel 13

100kHz PSD reference Level

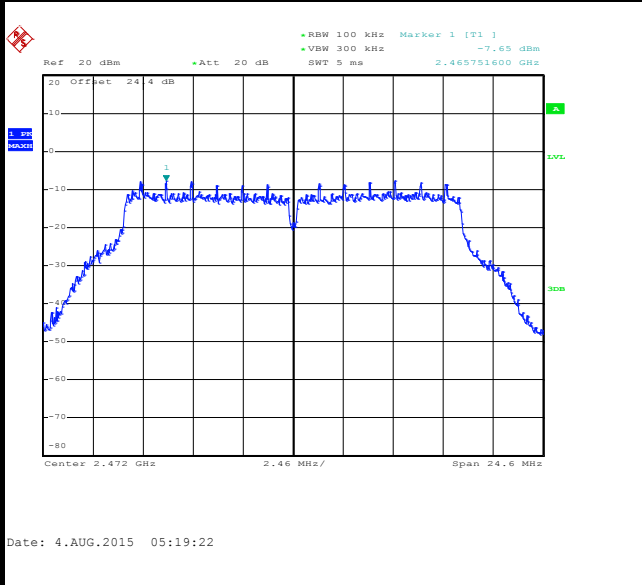

High Channel Plot

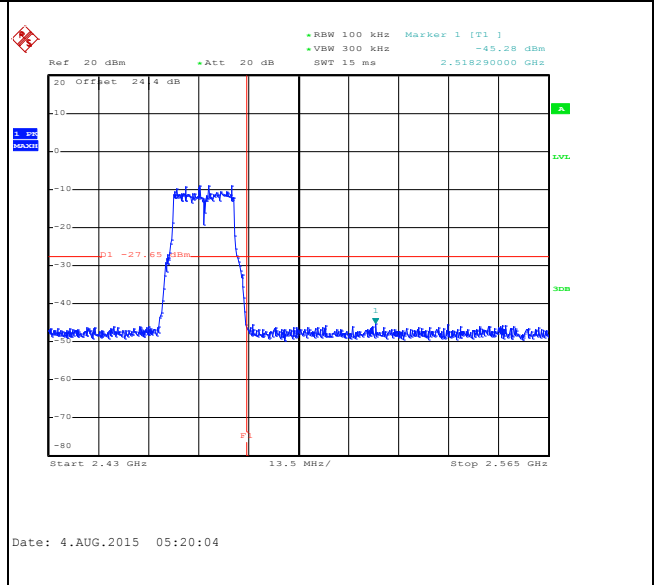

Spurious Emission 30MHz~3GHz

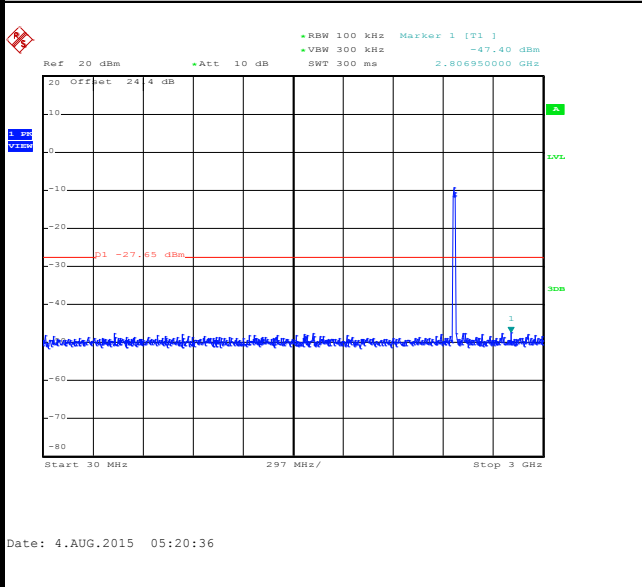

Spurious Emission 2GHz~25GHz

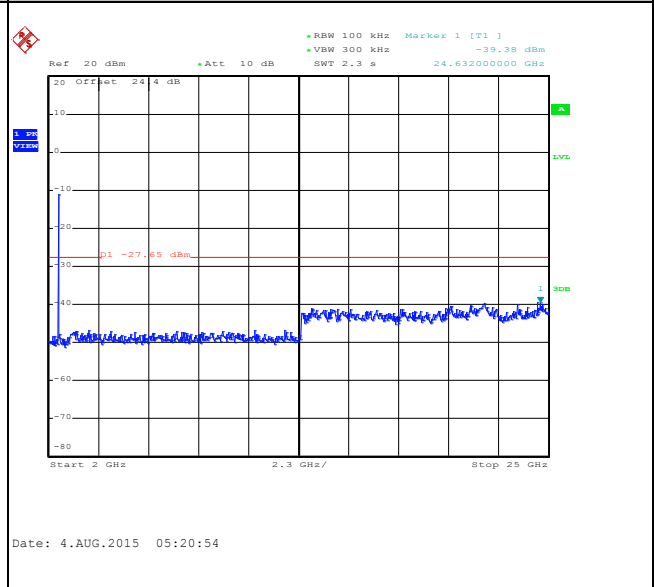



Number of TX :	2	Ant. :	1
Test Mode :	802.11n HT20	Temperature :	22~23°C
Test Band :	2.4GHz Low	Relative Humidity :	52~53%
Test Channel :	01	Test Engineer :	Osolemio Chang

WLAN 802.11n HT20 Channel 01

100kHz PSD reference Level

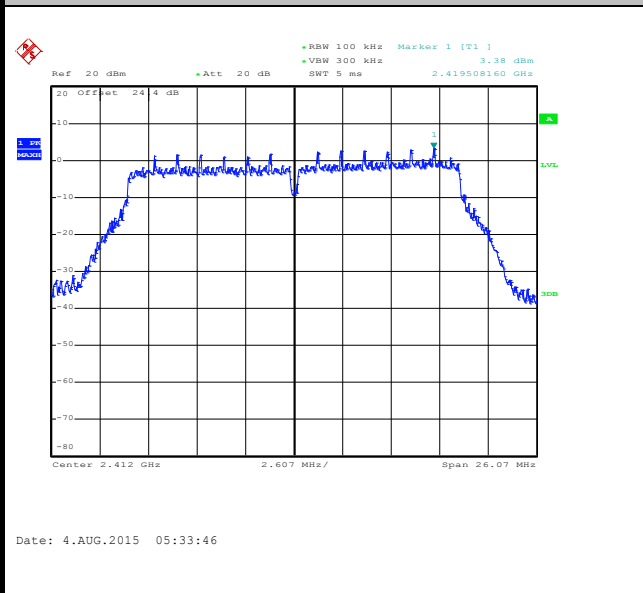

Low Channel Plot

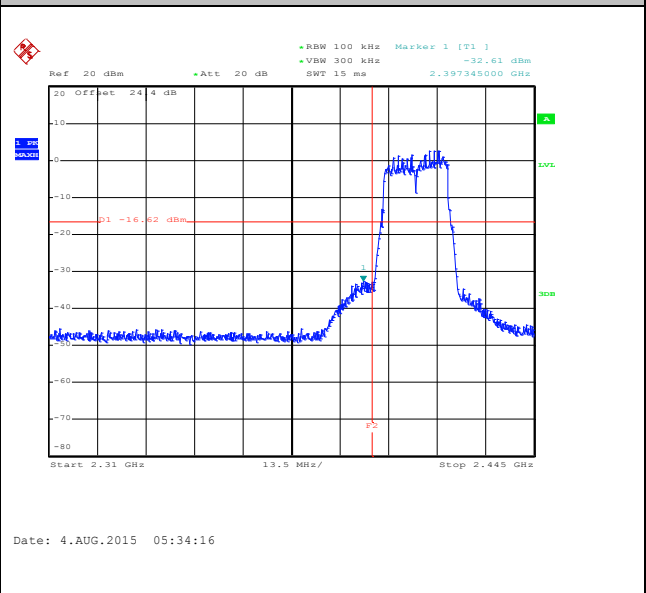

Spurious Emission 30MHz~3GHz

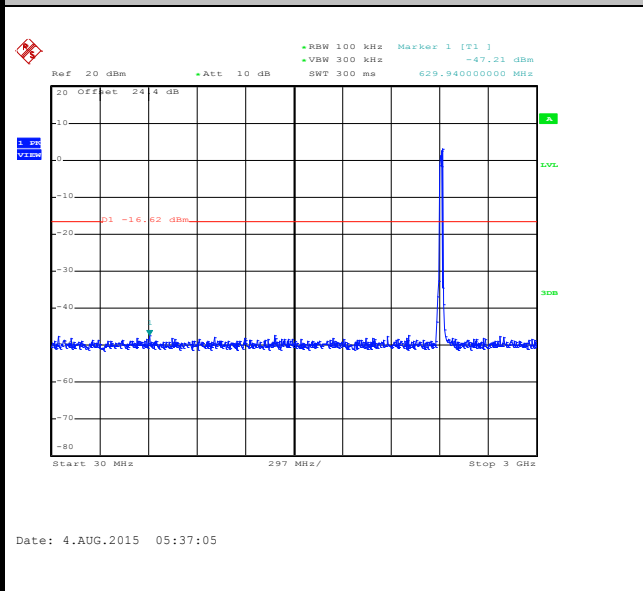

Spurious Emission 2GHz~25GHz

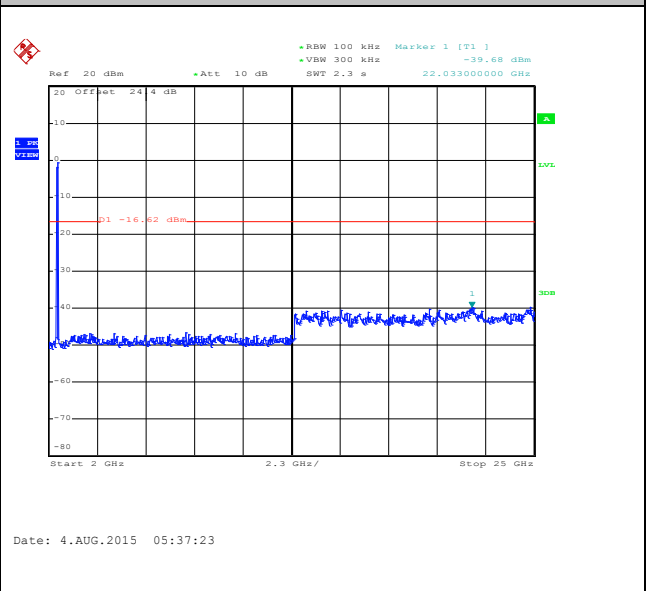



Number of TX :	2	Ant. :	1
Test Mode :	802.11n HT20	Temperature :	22~23°C
Test Band :	2.4GHz Mid	Relative Humidity :	52~53%
Test Channel :	06	Test Engineer :	Osolemio Chang

WLAN 802.11n HT20 Channel 06

100kHz PSD reference Level

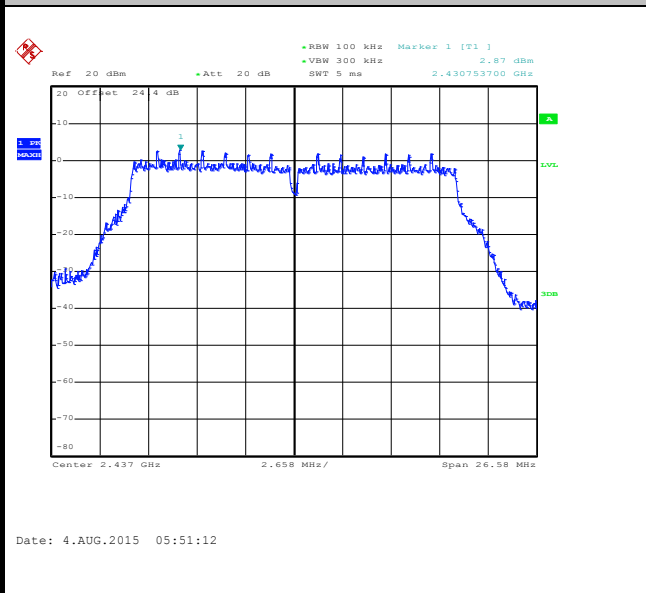

Spurious Emission 30MHz~3GHz

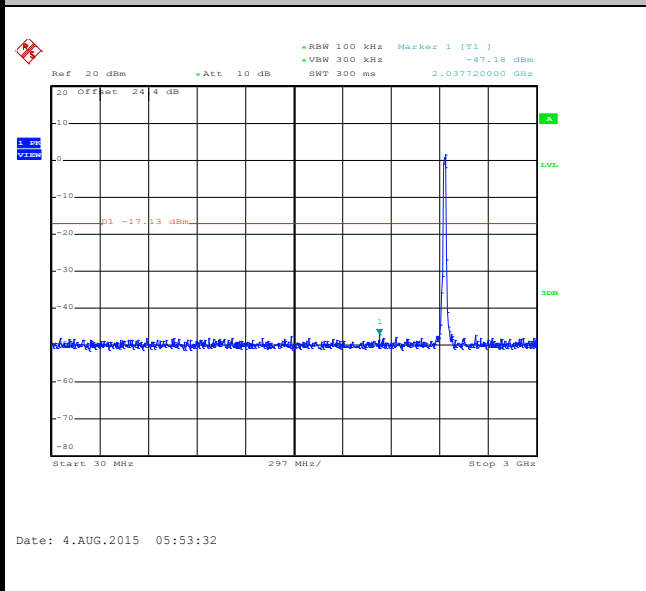

Spurious Emission 2GHz~25GHz

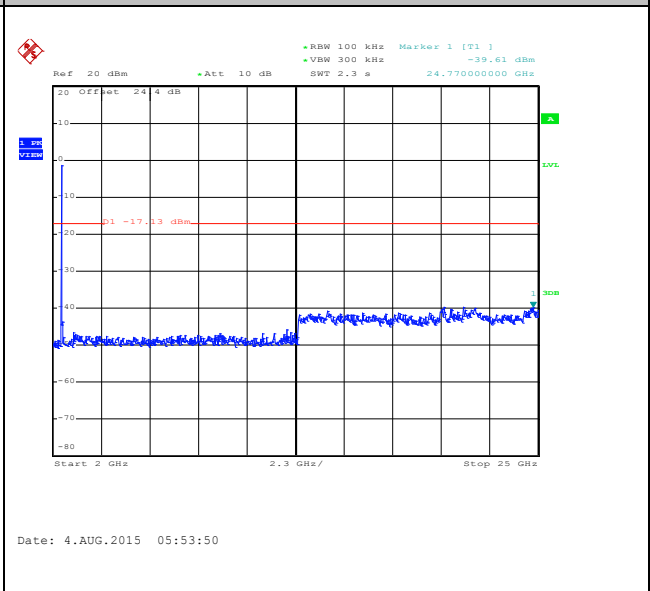



Number of TX :	2	Ant. :	1
Test Mode :	802.11n HT20	Temperature :	22~23°C
Test Band :	2.4GHz High	Relative Humidity :	52~53%
Test Channel :	11	Test Engineer :	Osolemio Chang

WLAN 802.11n HT20 Channel 11

100kHz PSD reference Level

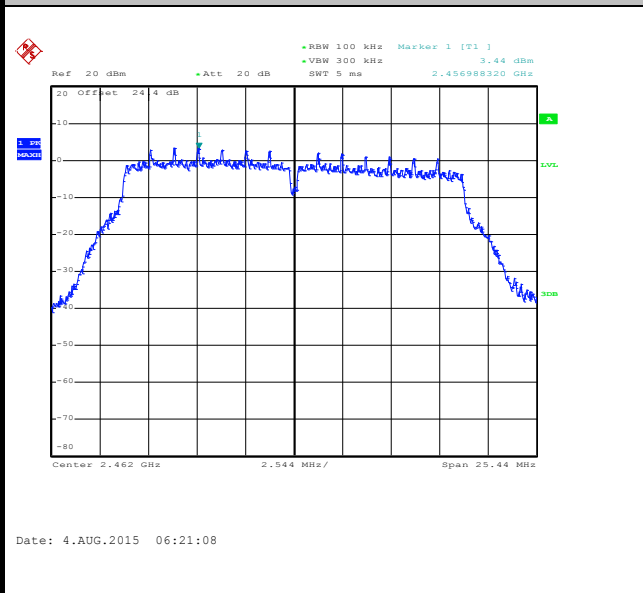

High Channel Plot

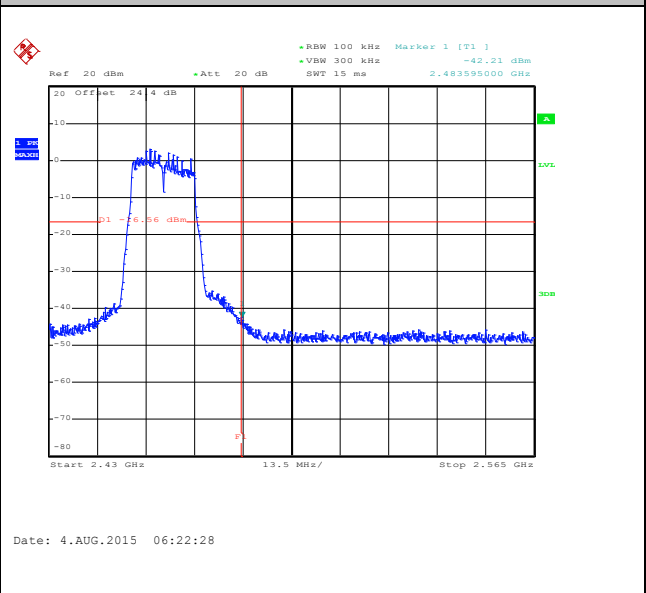

Spurious Emission 30MHz~3GHz

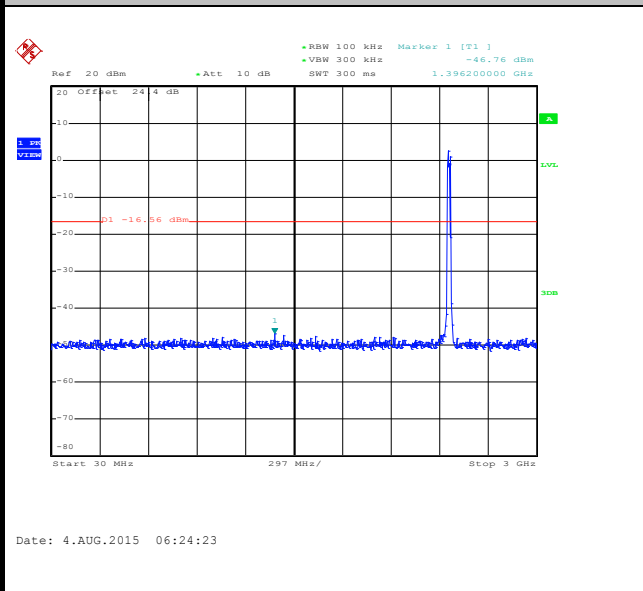

Spurious Emission 2GHz~25GHz

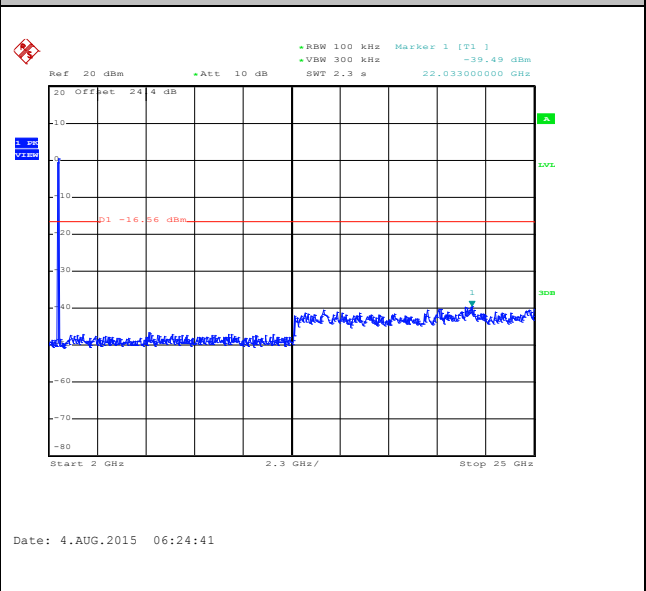



Number of TX :	2	Ant. :	1
Test Mode :	802.11n HT20	Temperature :	22~23°C
Test Band :	2.4GHz High	Relative Humidity :	52~53%
Test Channel :	12	Test Engineer :	Osolemio Chang

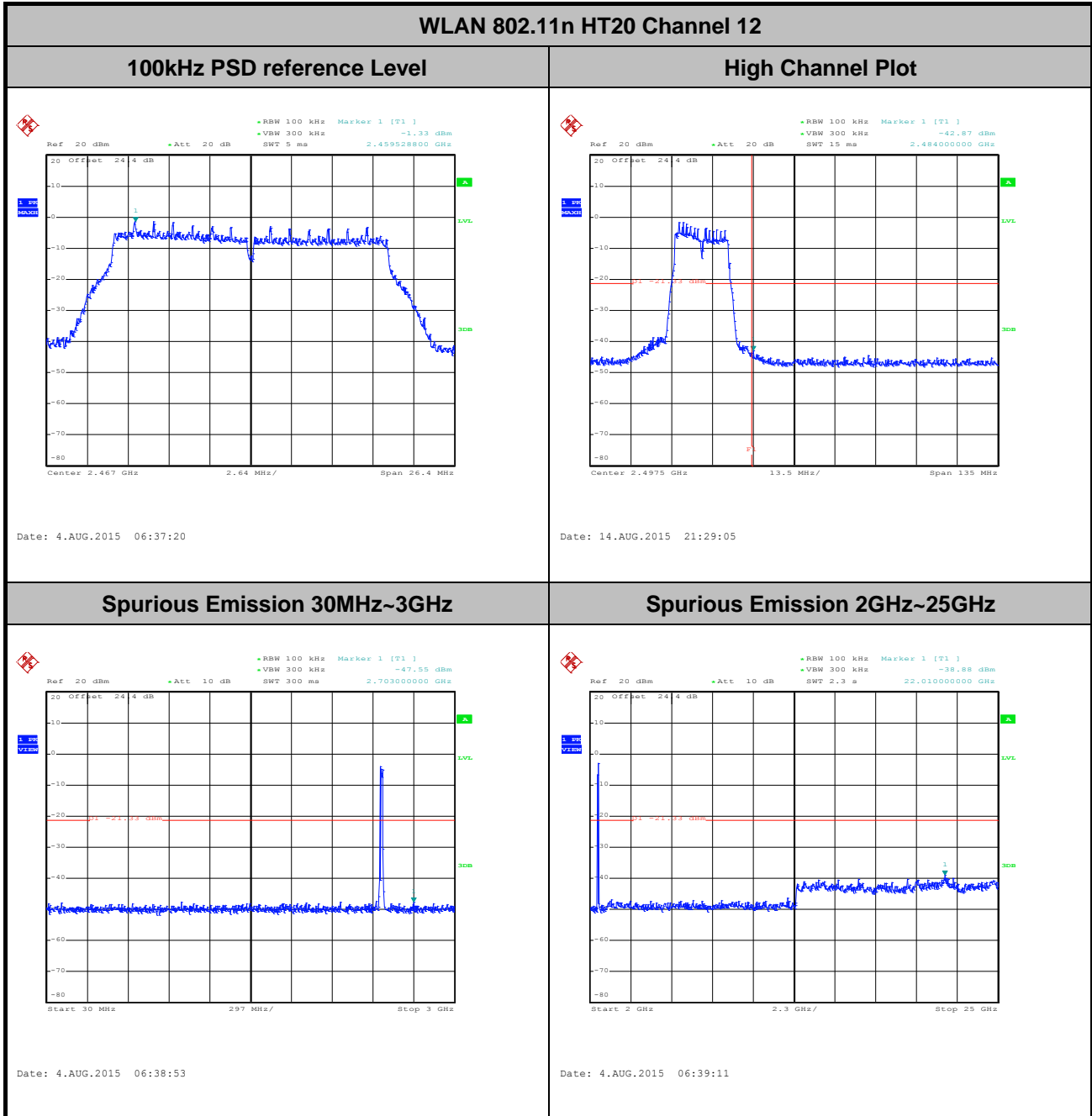



Number of TX :	2	Ant. :	1
Test Mode :	802.11n HT20	Temperature :	22~23°C
Test Band :	2.4GHz High	Relative Humidity :	52~53%
Test Channel :	13	Test Engineer :	Osolemio Chang

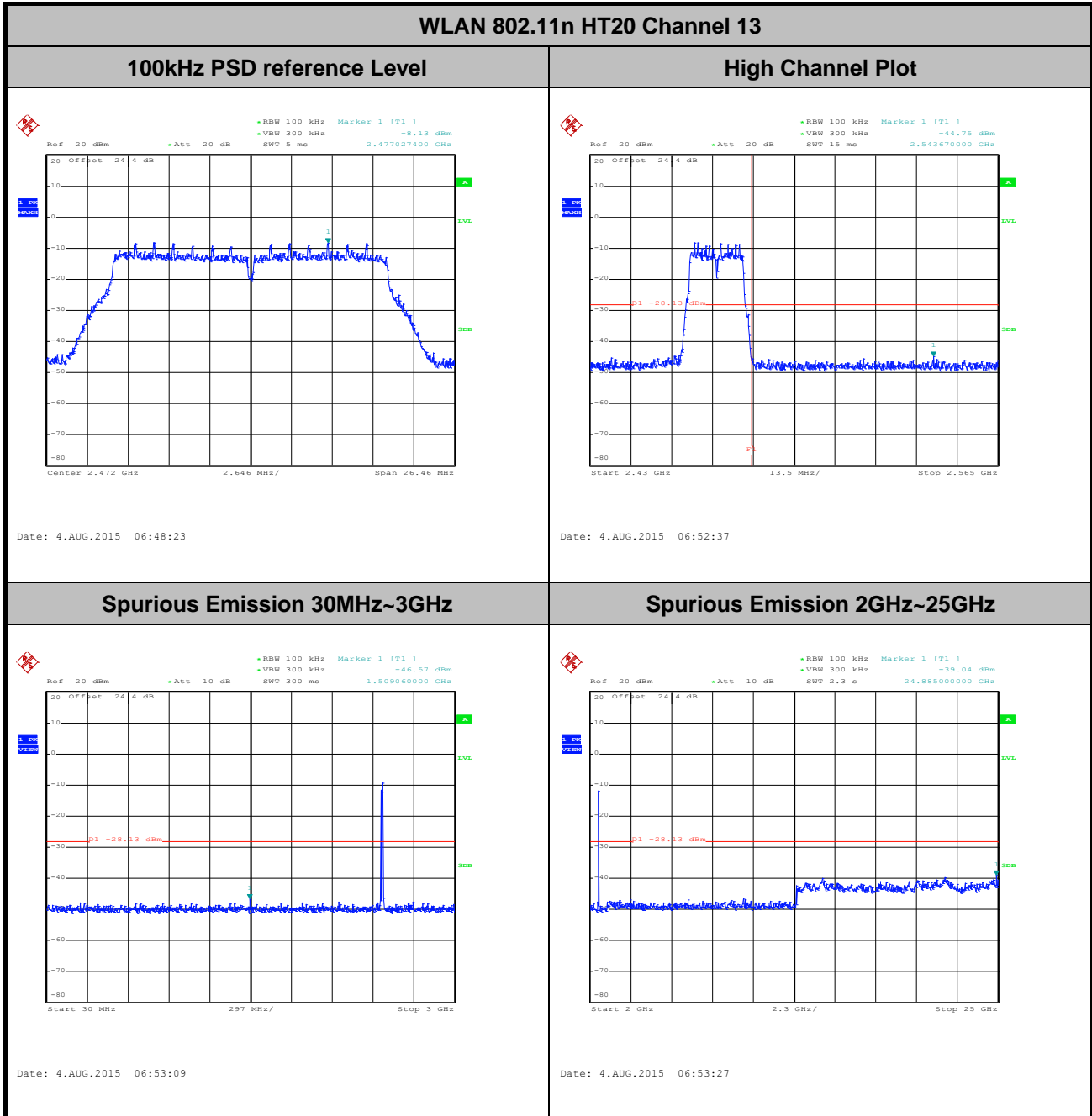



Number of TX = 2, Ant. 2 (Measured)

Number of TX :	2	Ant. :	2
Test Mode :	802.11g	Temperature :	22~23°C
Test Band :	2.4GHz Low	Relative Humidity :	52~53%
Test Channel :	01	Test Engineer :	Osolemio Chang

WLAN 802.11g Channel 01

100kHz PSD reference Level

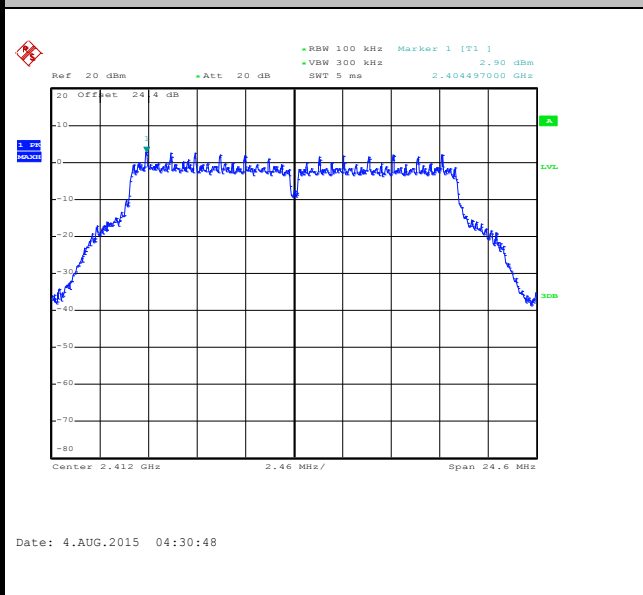

Low Channel Plot

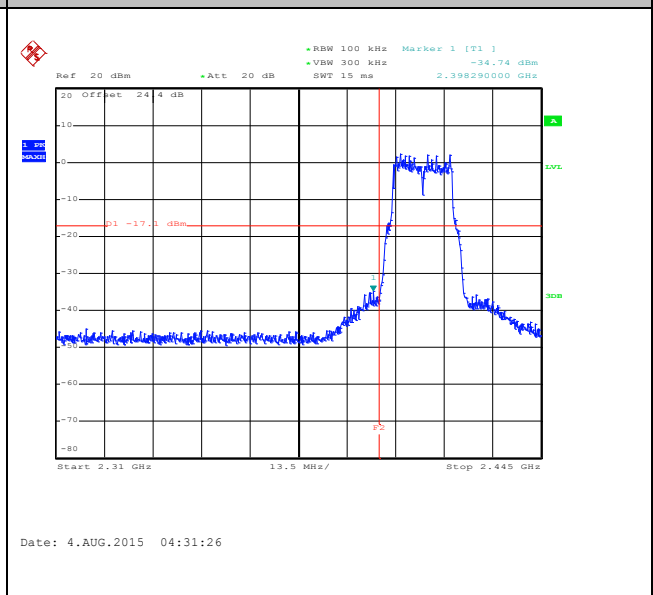

Spurious Emission 30MHz~3GHz

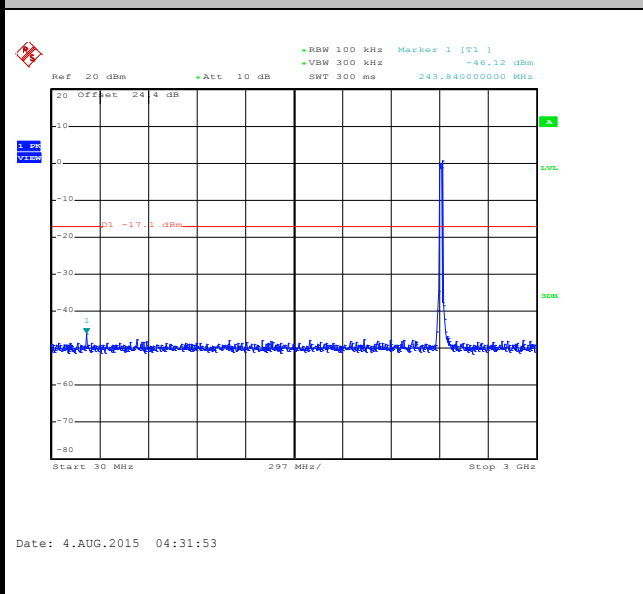

Spurious Emission 2GHz~25GHz

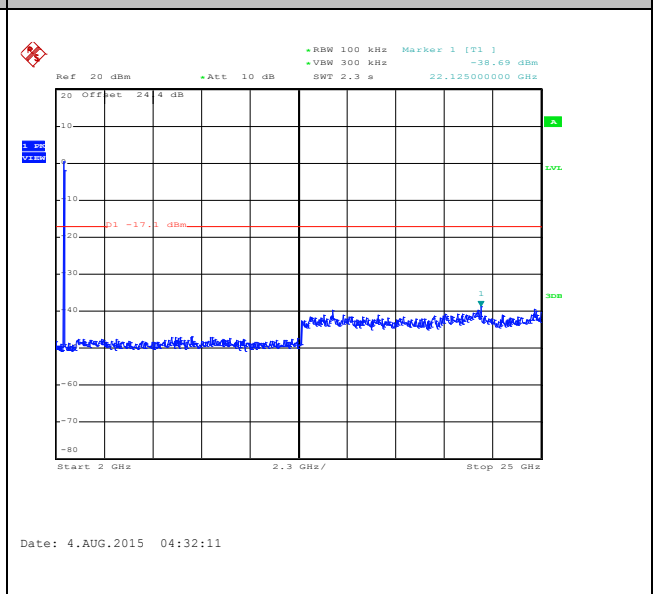



Number of TX :	2	Ant. :	2
Test Mode :	802.11g	Temperature :	22~23°C
Test Band :	2.4GHz Mid	Relative Humidity :	52~53%
Test Channel :	06	Test Engineer :	Osolemio Chang

WLAN 802.11g Channel 06

100kHz PSD reference Level

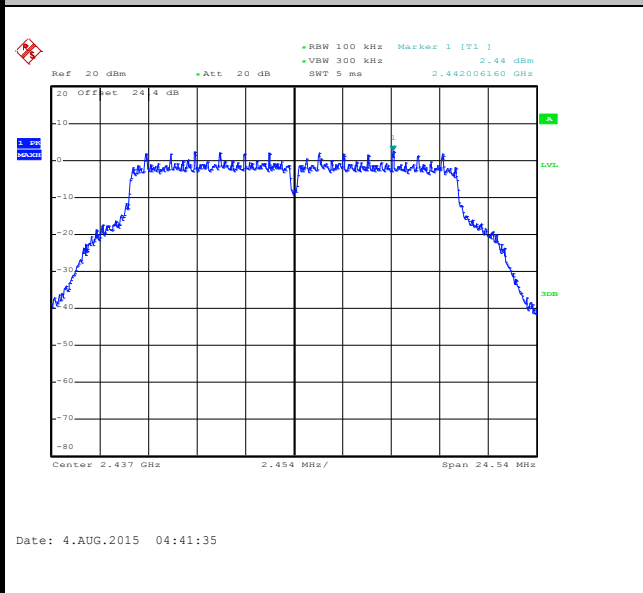

Spurious Emission 30MHz~3GHz

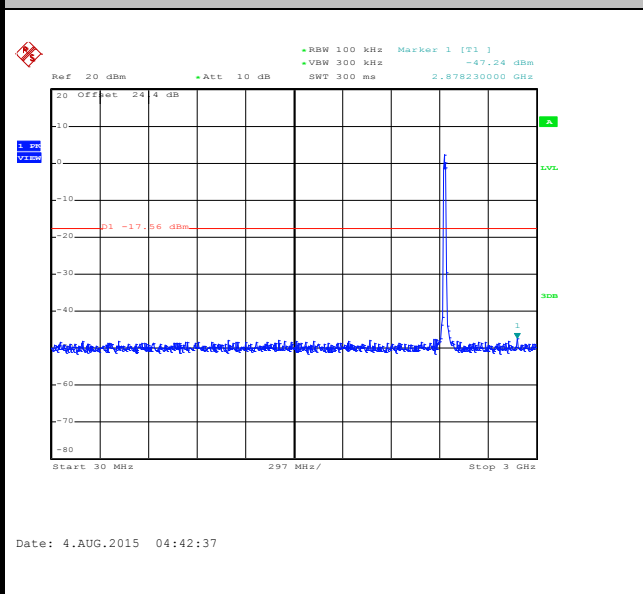

Spurious Emission 2GHz~25GHz

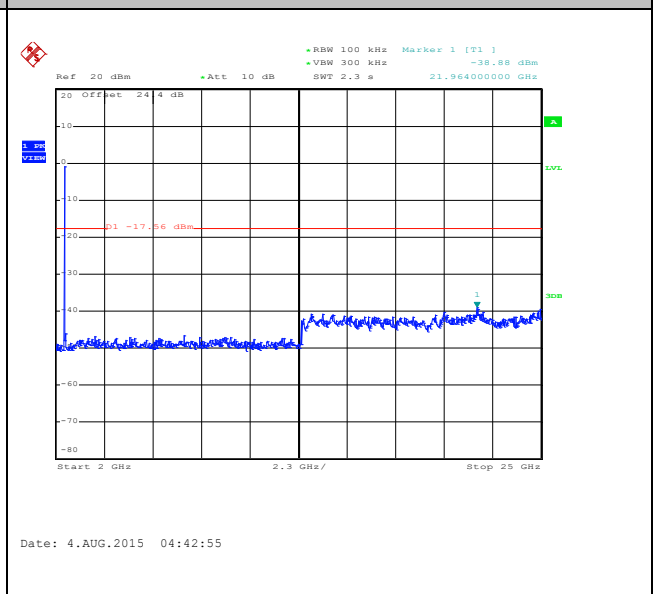



Number of TX :	2	Ant. :	2
Test Mode :	802.11g	Temperature :	22~23°C
Test Band :	2.4GHz High	Relative Humidity :	52~53%
Test Channel :	11	Test Engineer :	Osolemio Chang

WLAN 802.11g Channel 11

100kHz PSD reference Level

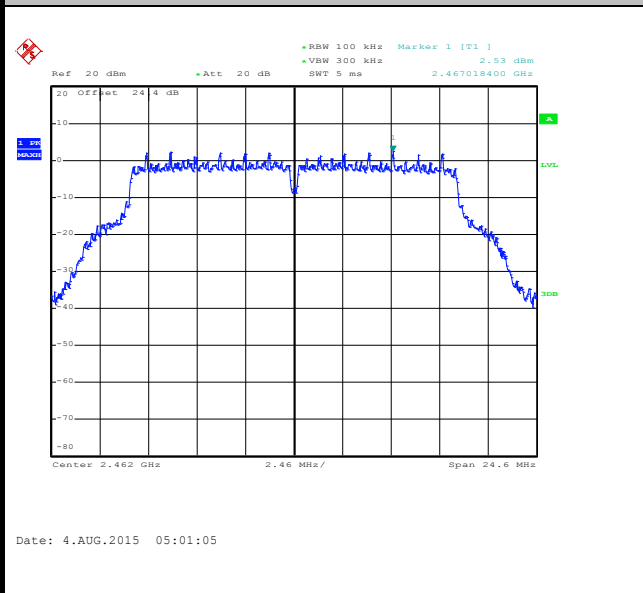

High Channel Plot

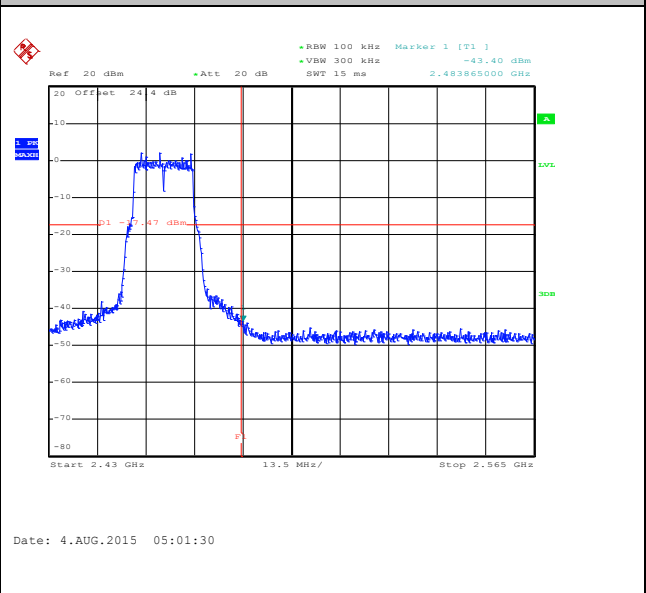

Spurious Emission 30MHz~3GHz

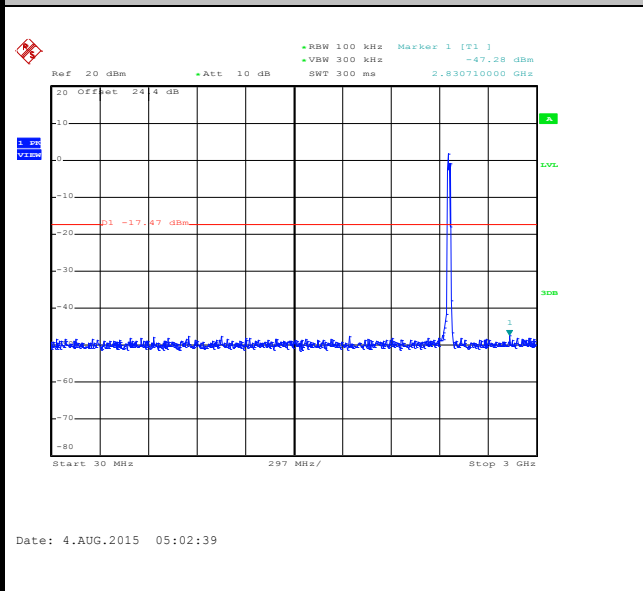

Spurious Emission 2GHz~25GHz

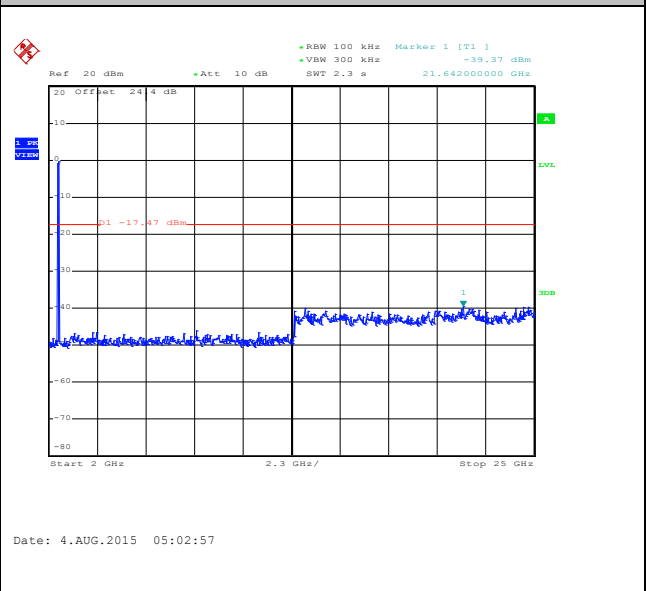



Number of TX :	2	Ant. :	2
Test Mode :	802.11g	Temperature :	22~23°C
Test Band :	2.4GHz High	Relative Humidity :	52~53%
Test Channel :	12	Test Engineer :	Osolemio Chang

WLAN 802.11g Channel 12

100kHz PSD reference Level

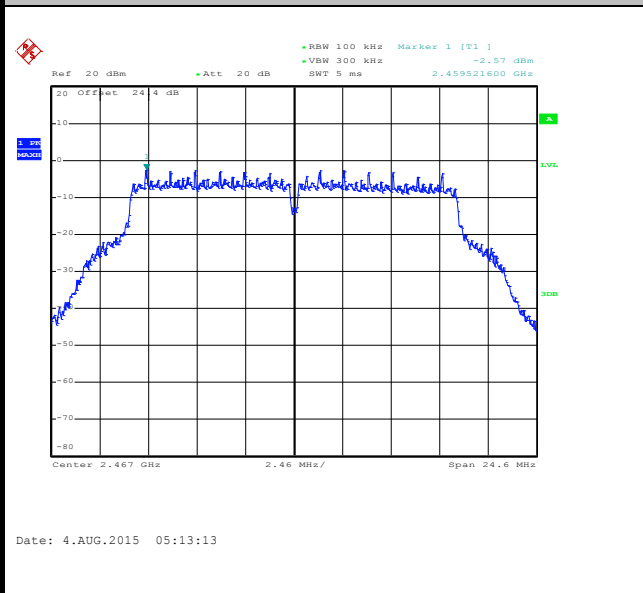

High Channel Plot

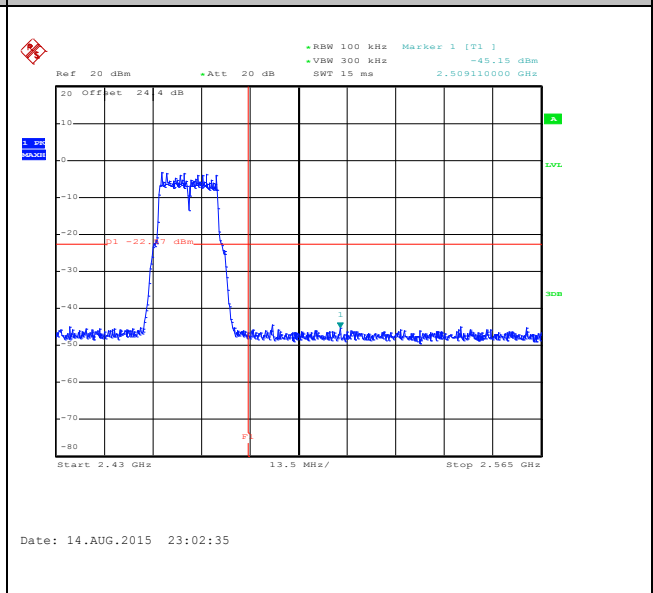

Spurious Emission 30MHz~3GHz

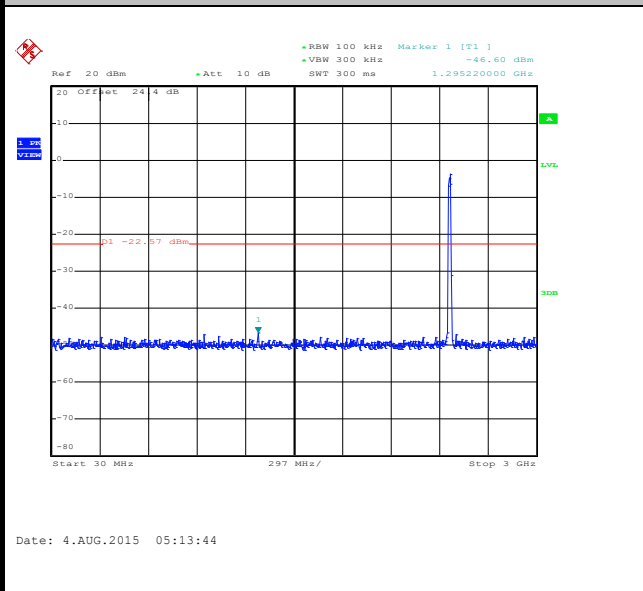

Spurious Emission 2GHz~25GHz

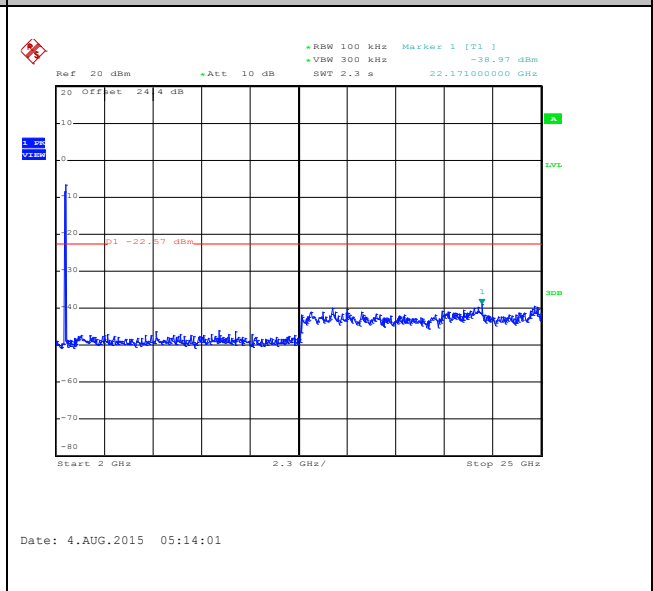



Number of TX :	2	Ant. :	2
Test Mode :	802.11g	Temperature :	22~23°C
Test Band :	2.4GHz High	Relative Humidity :	52~53%
Test Channel :	13	Test Engineer :	Osolemio Chang

WLAN 802.11g Channel 13

100kHz PSD reference Level

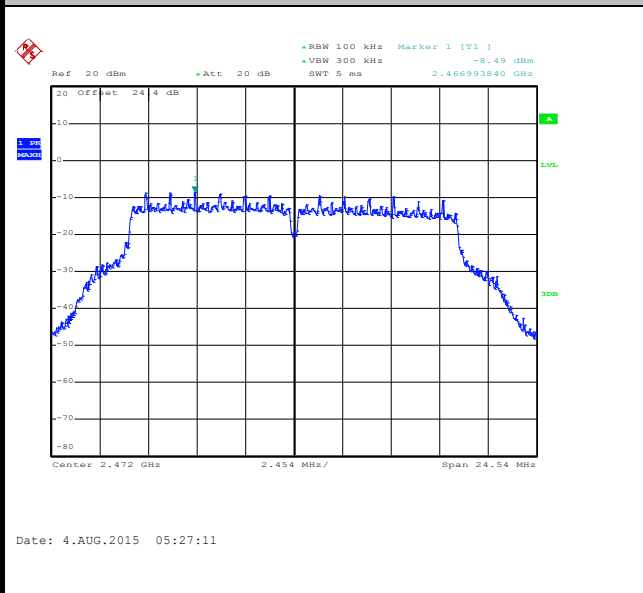

High Channel Plot

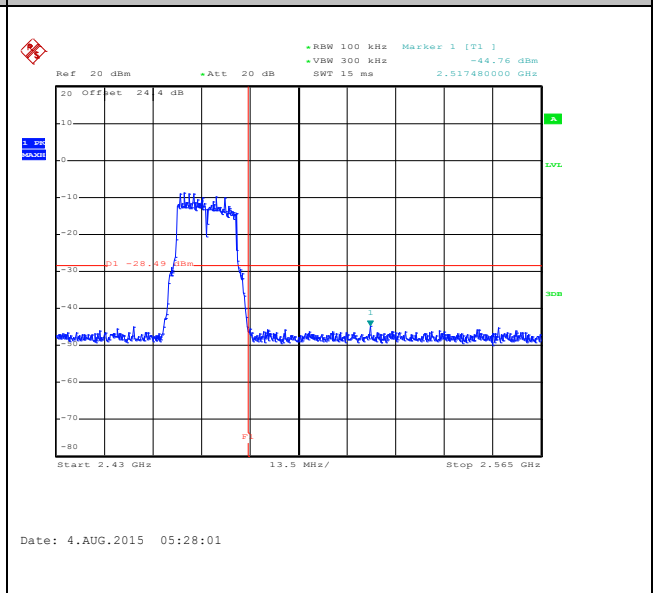

Spurious Emission 30MHz~3GHz

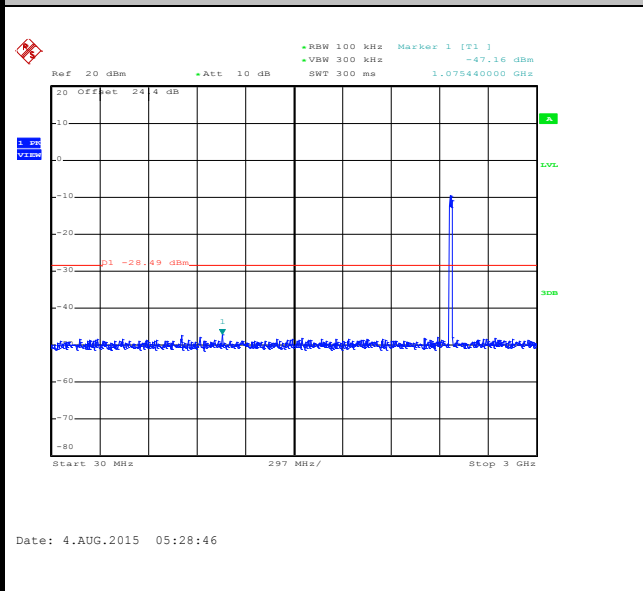

Spurious Emission 2GHz~25GHz

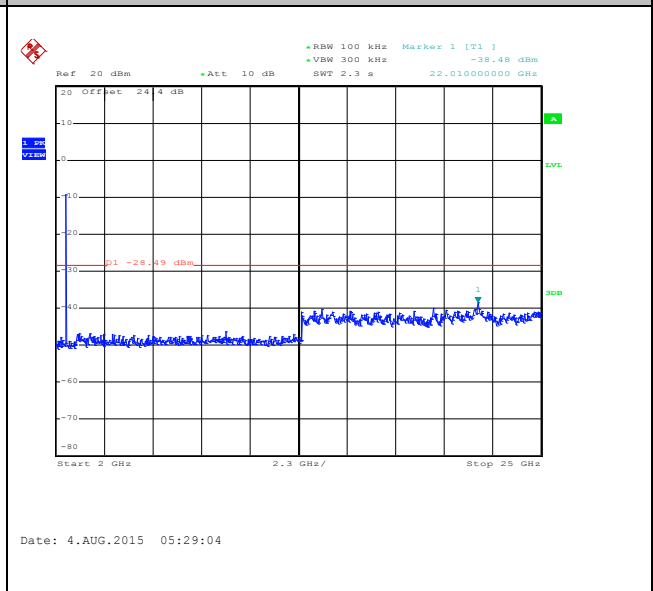



Number of TX :	2	Ant. :	2
Test Mode :	802.11n HT20	Temperature :	22~23°C
Test Band :	2.4GHz Low	Relative Humidity :	52~53%
Test Channel :	01	Test Engineer :	Osolemio Chang

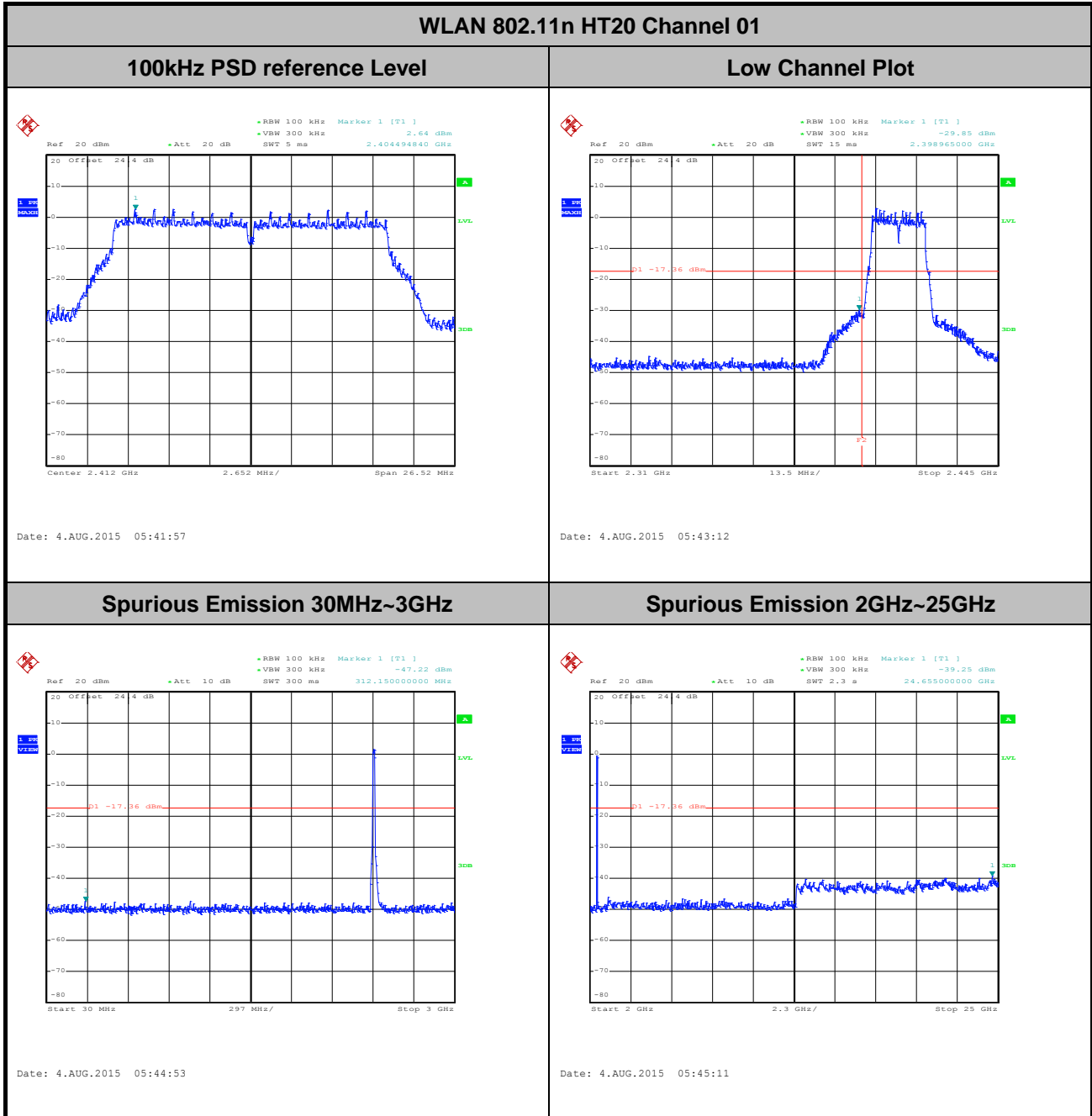



Number of TX :	2	Ant. :	2
Test Mode :	802.11n HT20	Temperature :	22~23°C
Test Band :	2.4GHz Mid	Relative Humidity :	52~53%
Test Channel :	06	Test Engineer :	Osolemio Chang

WLAN 802.11n HT20 Channel 06

100kHz PSD reference Level

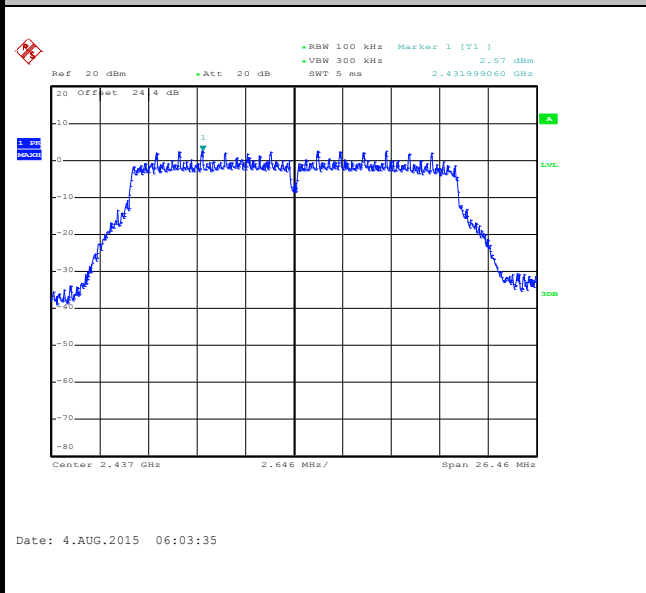

Spurious Emission 30MHz~3GHz

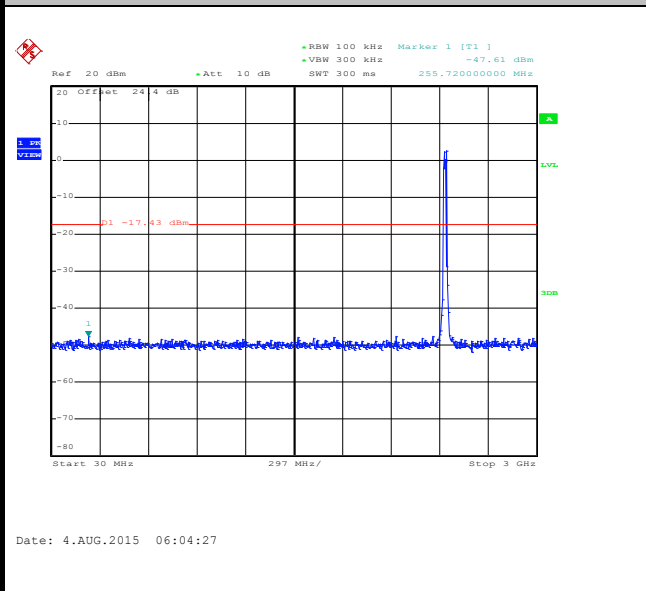

Spurious Emission 2GHz~25GHz

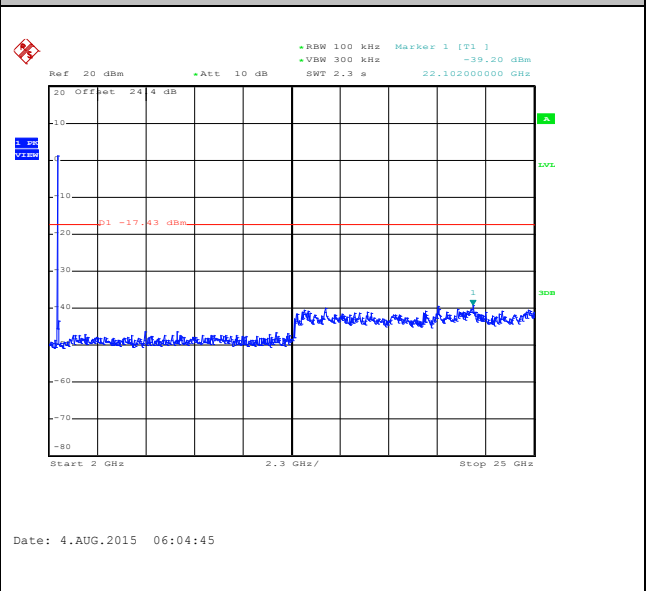



Number of TX :	2	Ant. :	2
Test Mode :	802.11n HT20	Temperature :	22~23°C
Test Band :	2.4GHz High	Relative Humidity :	52~53%
Test Channel :	11	Test Engineer :	Osolemio Chang

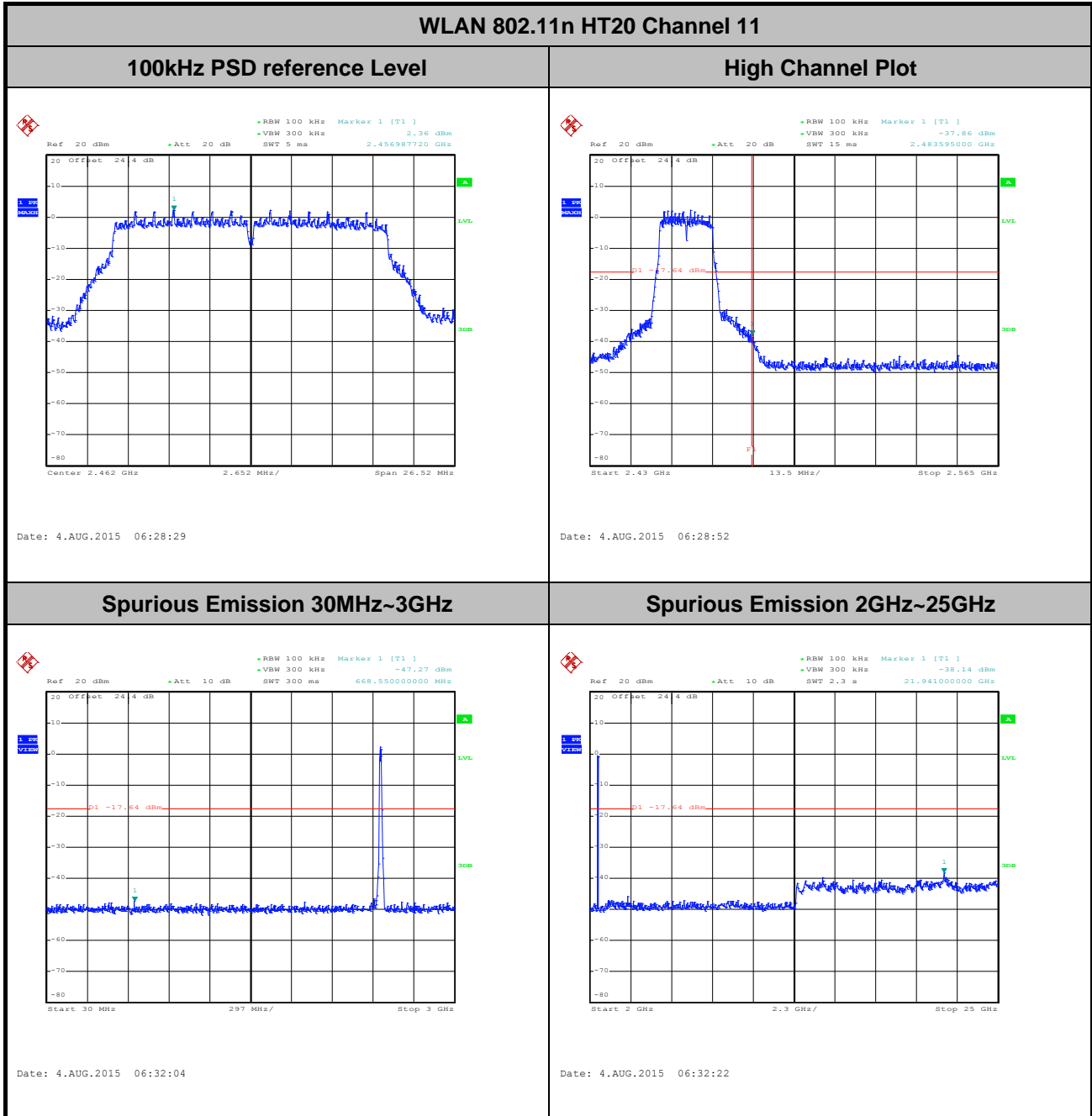



Number of TX :	2	Ant. :	2
Test Mode :	802.11n HT20	Temperature :	22~23°C
Test Band :	2.4GHz High	Relative Humidity :	52~53%
Test Channel :	12	Test Engineer :	Osolemio Chang

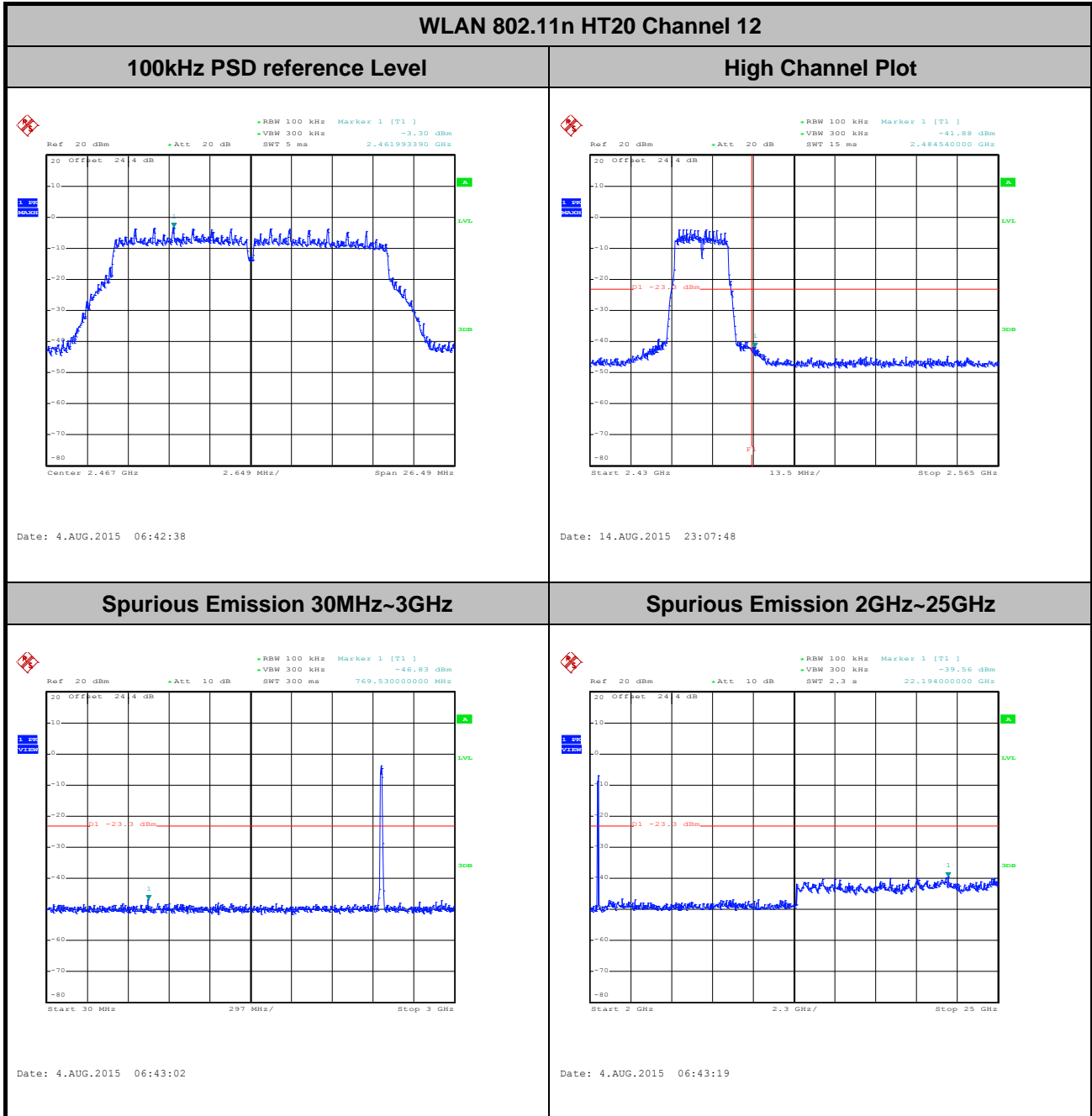



Number of TX :	2	Ant. :	2
Test Mode :	802.11n HT20	Temperature :	22~23°C
Test Band :	2.4GHz High	Relative Humidity :	52~53%
Test Channel :	13	Test Engineer :	Osolemio Chang

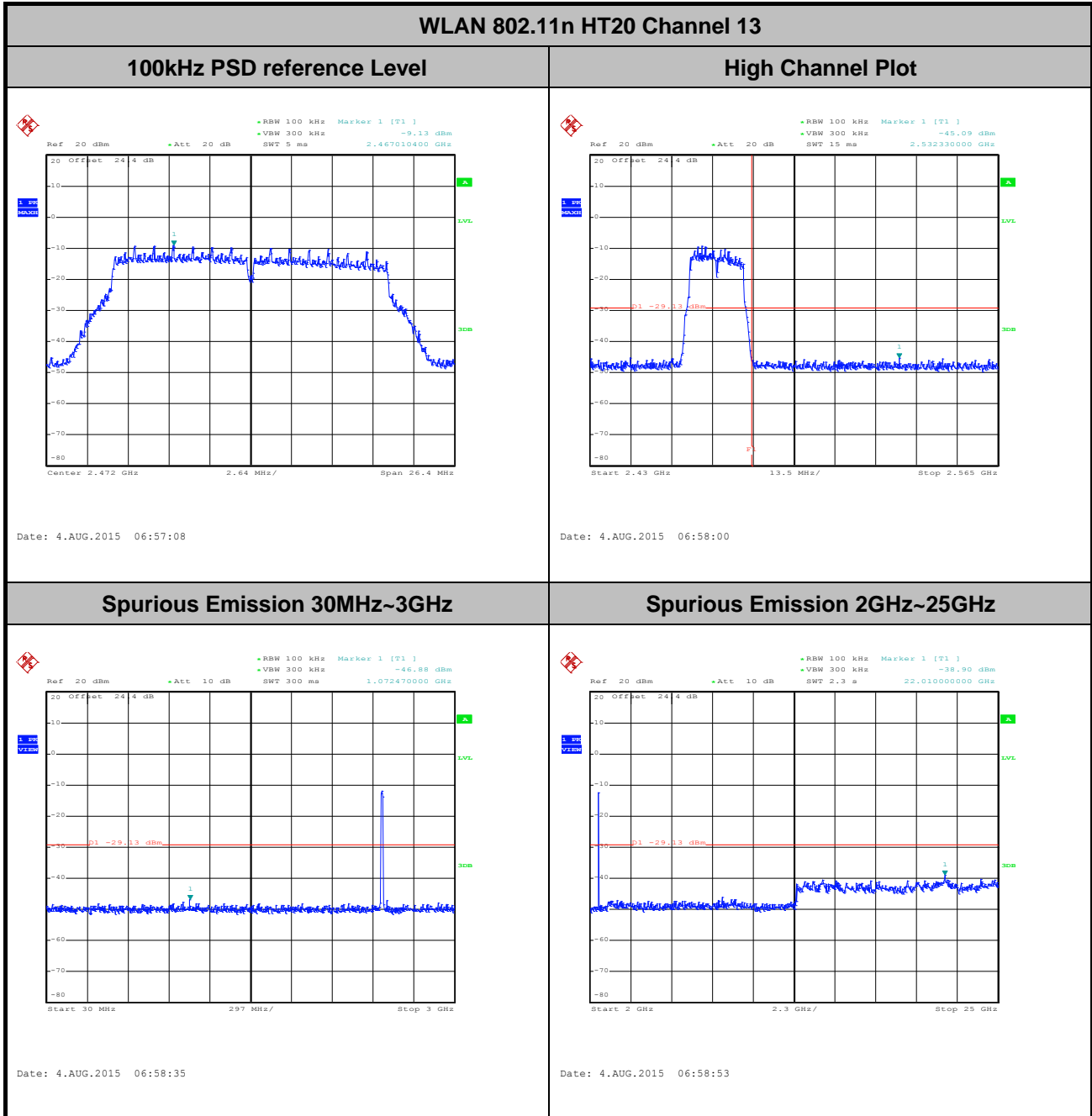



3.5 Radiated Band Edges and Spurious Emission Measurement

3.5.1 Limit of Radiated band edge and Spurious Emission Measurement

In any 100 kHz bandwidth outside the intentional radiator frequency band, all harmonics/spurious must be at least 20 dB below the highest emission level within the authorized band. If the output power of this device was measured by spectrum analyzer, the attenuation under this paragraph shall be 30 dB instead of 20 dB. In addition, radiated emissions which fall in the restricted bands must also comply with the FCC section 15.209 limits as below.

Frequency (MHz)	Field Strength (microvolts/meter)	Measurement Distance (meters)
0.009 – 0.490	2400/F(kHz)	300
0.490 – 1.705	24000/F(kHz)	30
1.705 – 30.0	30	30
30 – 88	100	3
88 – 216	150	3
216 - 960	200	3
Above 960	500	3

3.5.2 Measuring Instruments

The measuring equipment is listed in the section 4 of this test report.



3.5.3 Test Procedure

1. The testing follows FCC KDB Publication No. 558074 D01 DTS Meas. Guidance v03r03.
2. The EUT was arranged to its worst case and then tune the antenna tower (from 1 m to 4 m) and turntable (from 0 degree to 360 degrees) to find the maximum reading. A pre-amp and a high pass filter are used for the test in order to get better signal level.
3. The EUT was placed on a turntable with 0.8 meter for frequency below 1GHz and 1.5 meter for frequency above 1GHz respectively above ground.
4. The EUT was set 3 meters from the interference receiving antenna, which was mounted on the top of a variable height antenna tower.
5. Corrected Reading: Antenna Factor + Cable Loss + Read Level - Preamp Factor = Level
6. For measurement below 1GHz, If the emission level of the EUT measured by the peak detector is 3 dB lower than the applicable limit, the peak emission level will be reported. Otherwise, the emission measurement will be repeated using the quasi-peak detector and reported.
7. Use the following spectrum analyzer settings:
 - (1) Span shall wide enough to fully capture the emission being measured;
 - (2) Set RBW=100 kHz for $f < 1 \text{ GHz}$; $\text{VBW} \geq \text{RBW}$; Sweep = auto; Detector function = peak; Trace = max hold;
 - (3) Set RBW = 1 MHz, VBW= 3MHz for $f \geq 1 \text{ GHz}$ for peak measurement.
 For average measurement:
 - $\text{VBW} = 10 \text{ Hz}$, when duty cycle is no less than 98 percent.
 - $\text{VBW} \geq 1/T$, when duty cycle is less than 98 percent where T is the minimum transmission duration over which the transmitter is on and is transmitting at its maximum power control level for the tested mode of operation.

Antenna	Band	Duty Cycle(%)	T(us)	1/T(kHz)	VBW Setting
0	802.11b	99.10	-	-	10Hz
1	802.11b	99.11	-	-	
1+2	2.4GHz 802.11g for Ant 1	100	-	-	
1+2	2.4GHz 802.11g for Ant 2	100	-	-	
1+2	2.4GHz 802.11n HT20 for Ant 1	100	-	-	
1+2	2.4GHz 802.11n HT20 for Ant 2	100	-	-	

3.5.4 Test Setup

For radiated emissions below 30MHz

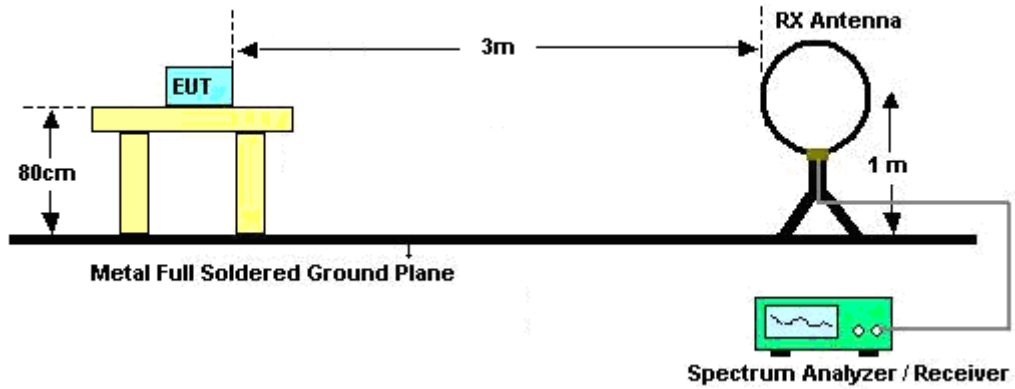

For radiated emissions from 30MHz to 1GHz

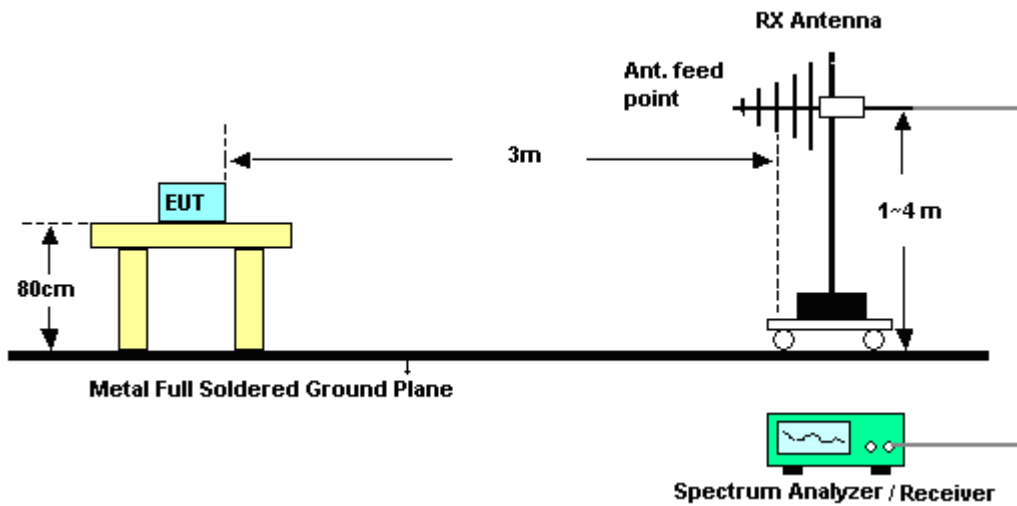

For radiated emissions above 1GHz

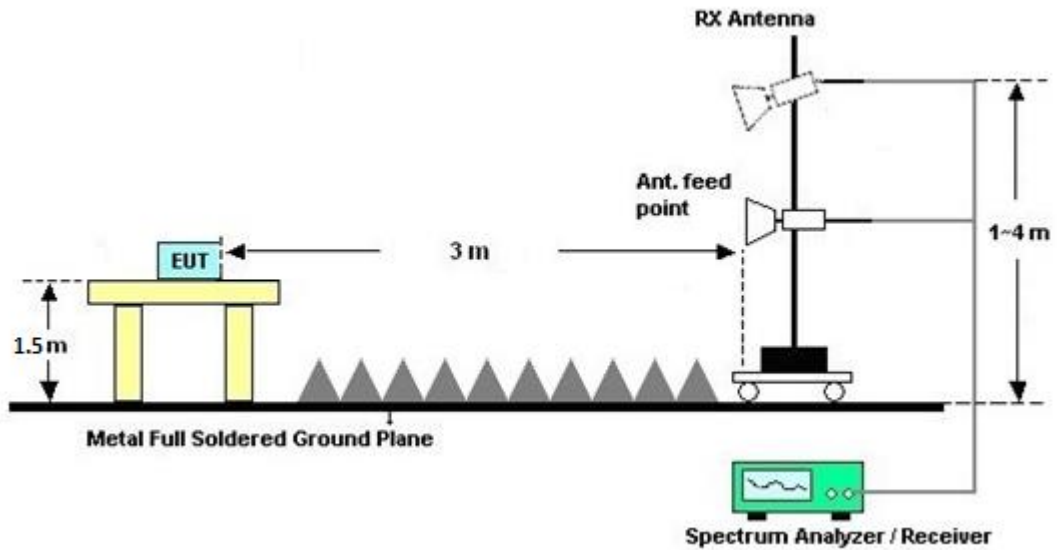

3.5.5 Test Results of Radiated Emissions (9kHz ~ 30MHz)

The low frequency, which started from 9 kHz to 30MHz, was pre-scanned and the result which was 20dB lower than the limit line per 15.31(o) was not reported.

3.5.6 Test Result of Radiated Spurious at Band Edges

Please refer to Appendix B and C of this test report.

3.5.7 Test Result of Radiated Spurious Emission (30MHz ~ 10th Harmonic)

Please refer to Appendix B and C of this test report.



3.6 AC Conducted Emission Measurement

3.6.1 Limit of AC Conducted Emission

For equipment that is designed to be connected to the public utility (AC) power line, the radio frequency voltage that is conducted back onto the AC power line on any frequency or frequencies within the band 150 kHz to 30 MHz shall not exceed the limits in the following table.

Frequency of Emission (MHz)	Conducted Limit (dBµV)	
	Quasi-Peak	Average
0.15-0.5	66 to 56*	56 to 46*
0.5-5	56	46
5-30	60	50

*Decreases with the logarithm of the frequency.

3.6.2 Measuring Instruments

The measuring equipment is listed in the section 4 of this test report.

3.6.3 Test Procedures

1. The EUT was placed 0.4 meter from the conducting wall of the shielding room, and it was kept at least 80 centimeters from any other grounded conducting surface.
2. Connect EUT to the power mains through a line impedance stabilization network (LISN).
3. All the support units are connecting to the other LISN.
4. The LISN provides 50 ohm coupling impedance for the measuring instrument.
5. The FCC states that a 50 ohm, 50 microhenry LISN should be used.
6. Both sides of AC line were checked for maximum conducted interference.
7. The frequency range from 150 kHz to 30 MHz was searched.
8. Set the test-receiver system to Peak Detect Function and specified bandwidth (IF bandwidth = 9kHz) with Maximum Hold Mode.

3.6.4 Test Setup

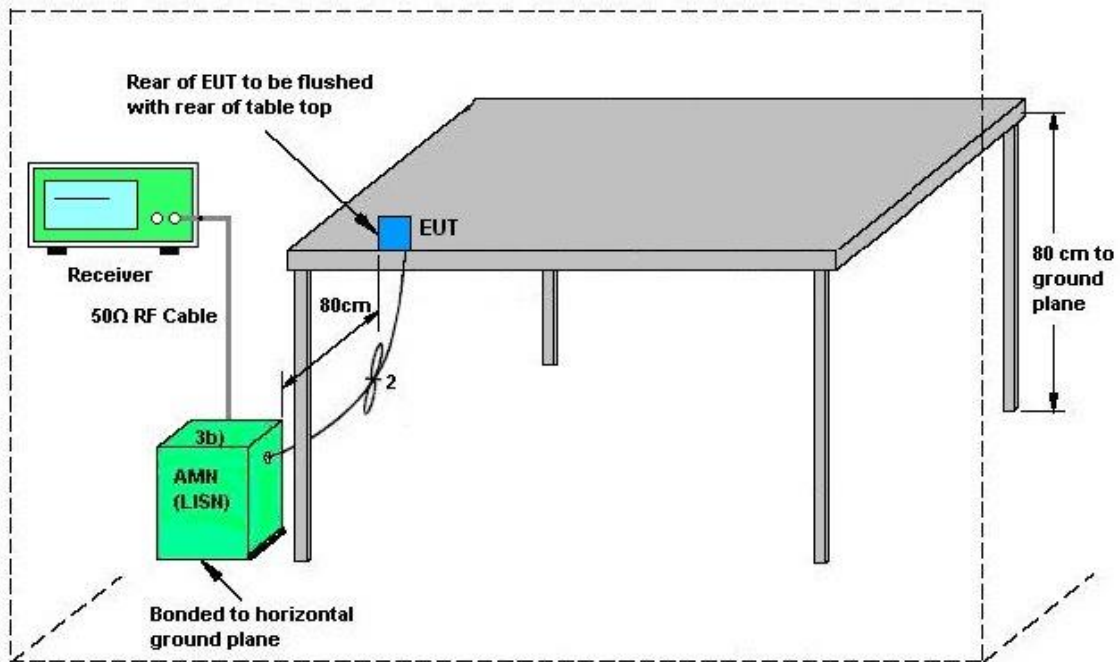

AMN = Artificial mains network (LISN)
AE = Associated equipment
EUT = Equipment under test
ISN = Impedance stabilization network



3.6.5 Test Result of AC Conducted Emission

Test Mode :	Mode 1	Temperature :	23~25°C
Test Engineer :	Eric Jeng	Relative Humidity :	58~61%
Test Voltage :	120Vac / 60Hz	Phase :	Line
Function Type :	WLAN 2.4GHz Link + USB Cable (Charging from Adapter) + Earphone		

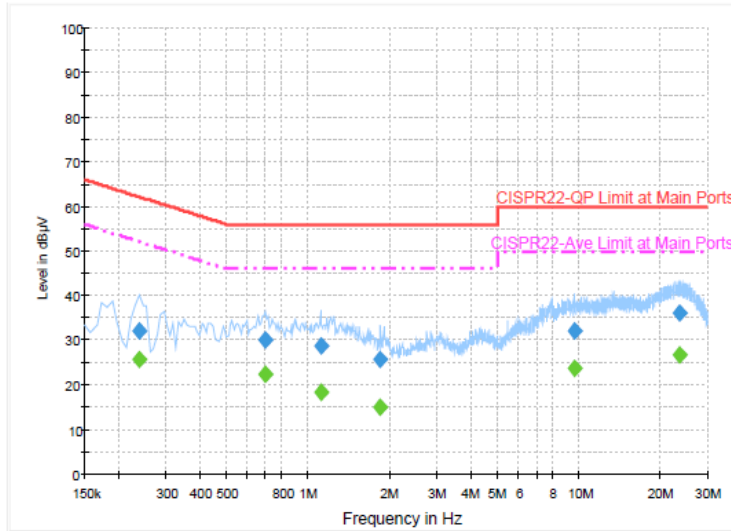

Final Result : QuasiPeak

Frequency (MHz)	QuasiPeak (dBµV)	Filter	Line	Corr. (dB)	Margin (dB)	Limit (dBµV)
0.238000	32.1	Off	L1	19.5	30.1	62.2
0.694000	30.0	Off	L1	19.6	26.0	56.0
1.118000	28.7	Off	L1	19.5	27.3	56.0
1.854000	25.7	Off	L1	19.5	30.3	56.0
9.694000	32.1	Off	L1	19.8	27.9	60.0
23.734000	36.2	Off	L1	20.0	23.8	60.0

Final Result : Average

Frequency (MHz)	Average (dBµV)	Filter	Line	Corr. (dB)	Margin (dB)	Limit (dBµV)
0.238000	25.7	Off	L1	19.5	26.5	52.2
0.694000	22.6	Off	L1	19.6	23.4	46.0
1.118000	18.4	Off	L1	19.5	27.6	46.0
1.854000	15.2	Off	L1	19.5	30.8	46.0
9.694000	23.8	Off	L1	19.8	26.2	50.0
23.734000	26.9	Off	L1	20.0	23.1	50.0



Test Mode :	Mode 1	Temperature :	23~25°C
Test Engineer :	Eric Jeng	Relative Humidity :	58~61%
Test Voltage :	120Vac / 60Hz	Phase :	Neutral
Function Type :	WLAN 2.4GHz Link + USB Cable (Charging from Adapter) + Earphone		

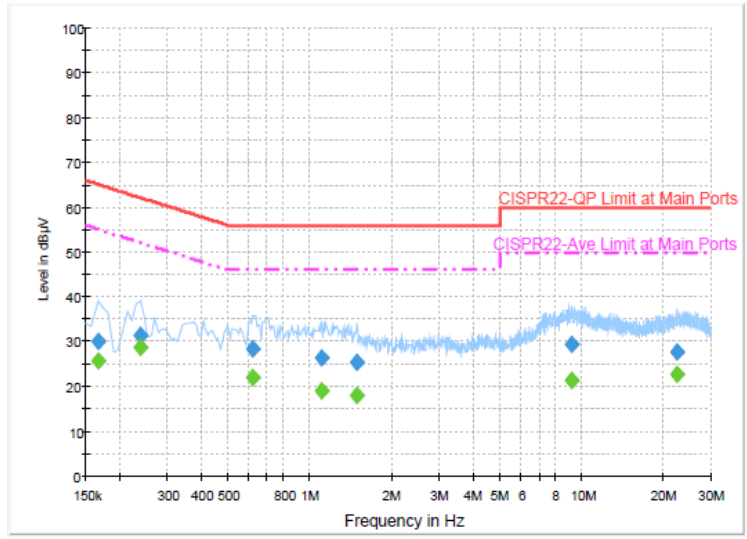

Final Result : QuasiPeak

Frequency (MHz)	QuasiPeak (dBµV)	Filter	Line	Corr. (dB)	Margin (dB)	Limit (dBµV)
0.166000	30.0	Off	N	19.4	35.2	65.2
0.238000	31.6	Off	N	19.5	30.6	62.2
0.622000	28.4	Off	N	19.4	27.6	56.0
1.110000	26.5	Off	N	19.5	29.5	56.0
1.494000	25.3	Off	N	19.6	30.7	56.0
9.198000	29.3	Off	N	19.8	30.7	60.0
22.430000	27.9	Off	N	20.1	32.1	60.0

Final Result : Average

Frequency (MHz)	Average (dBµV)	Filter	Line	Corr. (dB)	Margin (dB)	Limit (dBµV)
0.166000	25.7	Off	N	19.4	29.5	55.2
0.238000	28.6	Off	N	19.5	23.6	52.2
0.622000	22.0	Off	N	19.4	24.0	46.0
1.110000	19.1	Off	N	19.5	26.9	46.0
1.494000	18.0	Off	N	19.6	28.0	46.0
9.198000	21.5	Off	N	19.8	28.5	50.0
22.430000	22.7	Off	N	20.1	27.3	50.0

3.7 Antenna Requirements

3.7.1 Standard Applicable

If directional gain of transmitting Antennas is greater than 6dBi, the power shall be reduced by the same level in dB comparing to gain minus 6dBi. For the fixed point-to-point operation, the power shall be reduced by one dB for every 3 dB that the directional gain of the Antenna exceeds 6 dBi. The use of a permanently attached Antenna or of an Antenna that uses a unique coupling to the intentional radiator shall be considered sufficient to comply with the FCC rule.

3.7.2 Antenna Anti-Replacement Construction

An embedded-in antenna design is used.

3.7.3 Antenna Gain

FCC KDB 662911 D01 Multiple Transmitter Output v02r01.

For CDD transmissions, directional gain is calculated as

$$DirectionalGain = 10 \cdot \log \left[\frac{\sum_{j=1}^{N_{SS}} \left\{ \sum_{k=1}^{N_{ANT}} g_{j,k} \right\}^2}{N_{ANT}} \right]$$

where

Each antenna is driven by no more than one spatial stream;

N_{SS} = the number of independent spatial streams of data;

N_{ANT} = the total number of antennas

$g_{j,k} = 10^{G_k / 20}$ if the k th antenna is being fed by spatial stream j , or zero if it is not;

G_k is the gain in dBi of the k th antenna.



The EUT supports CDD mode.

The power and PSD limit should be modified if the directional gain of EUT is over 6 dBi,

The directional gain "DG" is calculated as following table.

			DG	DG	Power	PSD
			for	for	Limit	Limit
	Ant. 1	Ant. 2	Power	PSD	Reduction	Reduction
	(dBi)	(dBi)	(dBi)	(dBi)	(dB)	(dB)
2.4 GHz	-1.60	-4.10	0.25	0.25	0.00	0.00

$$\text{Power Limit Reduction} = DG(\text{Power}) - 6\text{dBi}, (\text{min} = 0)$$

$$\text{PSD Limit Reduction} = DG(\text{PSD}) - 6\text{dBi}, (\text{min} = 0)$$



4 List of Measuring Equipment

Instrument	Manufacturer	Model No.	Serial No.	Characteristics	Calibration Date	Test Date	Due Date	Remark
Power Meter	Anritsu	ML2495A	1218006	300MHz~40GHz	Oct. 18, 2014	Jul. 28, 2015~ Aug. 14, 2015	Oct. 17, 2015	Conducted (TH05-HY)
Power Sensor	Anritsu	MA2411B	1126017	300MHz~40GHz	Oct. 18, 2014	Jul. 28, 2015~ Aug. 14, 2015	Oct. 17, 2015	Conducted (TH05-HY)
Spectrum Analyzer	Rohde & Schwarz	FSP40	100055	9kHz-40GHz	Jun. 18, 2015	Jul. 28, 2015~ Aug. 14, 2015	Jun. 17, 2016	Conducted (TH05-HY)
Hygrometer	Testo	608-H1	34897199	N/A	May 04, 2015	Jul. 28, 2015~ Aug. 14, 2015	May 03, 2016	Conducted (TH05-HY)
RF Cable	HARBOUR INDUSTRIES	LL142	Infinet CA3601-360 1-DLL	0.1MHz~40GHz	Mar. 06, 2015	Jul. 28, 2015~ Aug. 14, 2015	Mar. 05, 2016	Conducted (TH05-HY)
Horn Antenna	SCHWARZBECK	BBHA 9170	BBHA91705 84	18GHz- 40GHz	Nov. 03, 2014	Aug. 05, 2015~ Aug. 26, 2015	Nov. 02, 2015	Radiation (03CH11-HY)
Loop Antenna	TESEQ	HLA 6120	31244	9kHz~30MHz	Feb. 02, 2015	Aug. 05, 2015~ Aug. 26, 2015	Feb. 01, 2016	Radiation (03CH11-HY)
RF Cable	HUBER + SUHNER	SUCOFLEX 104	MY84209521	9kHz~1GHz	Dec. 04, 2014	Aug. 05, 2015~ Aug. 26, 2015	Dec. 03, 2015	Radiation (03CH11-HY)
EMI Test Receiver	Keysight	N9038A	MY54130085	20Hz ~ 8.4GHz	Nov. 05, 2014	Aug. 05, 2015~ Aug. 26, 2015	Nov. 04, 2015	Radiation (03CH11-HY)
Amplifier	SONOMA	310N	187312	9kHz~1GHz	Nov. 24, 2014	Aug. 05, 2015~ Aug. 26, 2015	Nov. 23, 2015	Radiation (03CH11-HY)
Bilog Antenna	TESEQ	CBL 6111D	35414	30MHz~1GHz	Oct. 24, 2014	Aug. 05, 2015~ Aug. 26, 2015	Oct. 23, 2015	Radiation (03CH11-HY)
Horn Antenna	SCHWARZBECK	BBHA 9120 D	9120D-1326	1GHz ~ 18GHz	Oct. 03, 2014	Aug. 05, 2015~ Aug. 26, 2015	Oct. 02, 2015	Radiation (03CH11-HY)
Hygrometer	TECPEL	DTN-303B	TP140325	N/A	Nov. 19, 2014	Aug. 05, 2015~ Aug. 26, 2015	Nov. 18, 2015	Radiation (03CH11-HY)
Preamplifier	Keysight	83017A	MY53270080	1GHz~26.5GHz	Nov. 20, 2014	Aug. 05, 2015~ Aug. 26, 2015	Nov. 19, 2015	Radiation (03CH11-HY)
Preamplifier	MITEQ	AMF-7D-00101 800-30-10P	1902247	1GHz~18GHz	Jul. 01, 2015	Aug. 05, 2015~ Aug. 26, 2015	Jun. 30, 2016	Radiation (03CH11-HY)
Spectrum Analyzer	Keysight	N9010A	MY54200486	10Hz ~ 44GHZ	Sep. 24, 2014	Aug. 05, 2015~ Aug. 26, 2015	Sep. 23, 2015	Radiation (03CH11-HY)
Test Software	Audix	E3	6.2009-8-24	N/A	N/A	Aug. 05, 2015~ Aug. 26, 2015	N/A	Radiation (03CH11-HY)
RF Cable	HUBER + SUHNER	SUCOFLEX 104	MY24967/4 MY28419/4 MY28654/4	25GHz~40GHz	Nov. 06, 2014	Aug. 05, 2015~ Aug. 26, 2015	Nov. 05, 2015	Radiation (03CH11-HY)
RF Cable	HUBER + SUHNER	SUCOFLEX 104	MY24967/4 MY28419/4 MY28654/4	30MHz~1GHz	Nov. 06, 2014	Aug. 05, 2015~ Aug. 26, 2015	Nov. 05, 2015	Radiation (03CH11-HY)
RF Cable	HUBER + SUHNER	SUCOFLEX 104	MY24967/4 MY28419/4 MY28654/4	1GHz~25GHz	Nov. 06, 2014	Aug. 05, 2015~ Aug. 26, 2015	Nov. 05, 2015	Radiation (03CH11-HY)



Instrument	Manufacturer	Model No.	Serial No.	Characteristics	Calibration Date	Test Date	Due Date	Remark
Controller	EMEC	EM 1000	N/A	Control Turn table & Ant Mast	N/A	Aug. 05, 2015~ Aug. 26, 2015	N/A	Radiation (03CH11-HY)
Antenna Mast	EMEC	AM-BS-4500-B	N/A	1~4m	N/A	Aug. 05, 2015~ Aug. 26, 2015	N/A	Radiation (03CH11-HY)
Turn Table	EMEC	TT 2000	N/A	0-360 degree	N/A	Aug. 05, 2015~ Aug. 26, 2015	N/A	Radiation (03CH11-HY)
Preamplifier	MITEQ	JS44-1800400 0-33-8P	1840917	18GHz ~ 40GHz	Jun. 02, 2015	Aug. 05, 2015~ Aug. 26, 2015	Jun. 01, 2016	Radiation (03CH11-HY)
Filter	Wainwright	WLKS4500-8S S	SN19	4.5G Low Pass	Oct. 01, 2014	Aug. 05, 2015~ Aug. 26, 2015	Sep. 30, 2015	Radiation (03CH11-HY)
Filter	Microwave Circuits	H07G18G3	SN8009-01	7GHz HPF	Oct. 01, 2014	Aug. 05, 2015~ Aug. 26, 2015	Sep. 30, 2015	Radiation (03CH11-HY)
EMI Test Receiver	Rohde & Schwarz	ESCS 30	100356	9kHz – 2.75GHz	Dec. 01, 2014	Aug. 15, 2015	Nov. 30, 2015	Conduction (CO05-HY)
Hygrometer	Testo	608-H1	34913912	N/A	Apr. 20, 2015	Aug. 15, 2015	Apr. 19, 2016	Conduction (CO05-HY)
LISN	Rohde & Schwarz	ENV216	100080	9kHz~30MHz	Dec. 02, 2014	Aug. 15, 2015	Dec. 01, 2015	Conduction (CO05-HY)
AC Power Source()	ChainTek	APC-1000W	N/A	N/A	N/A	Aug. 15, 2015	N/A	Conduction (CO05-HY)
LF Cable	HUBER + SUHNER	RG-214/U	LF01	N/A	Jan. 07, 2015	Aug. 15, 2015	Jan. 06, 2016	Conduction (CO05-HY)
Test Software	N/A	EMC32	8.40.0	N/A	N/A	Aug. 15, 2015	N/A	Conduction (CO05-HY)



5 Uncertainty of Evaluation

Uncertainty of Conducted Emission Measurement (150kHz ~ 30MHz)

Measuring Uncertainty for a Level of Confidence of 95% ($U = 2Uc(y)$)	2.26
---	------

Uncertainty of Radiated Emission Measurement (30 MHz ~ 1000 MHz)

Measuring Uncertainty for a Level of Confidence of 95% ($U = 2Uc(y)$)	4.90
---	------



Appendix A. Conducted Test Results

Test Engineer:	Osolemio Chang	Temperature:	22~23	°C
Test Date:	2015/7/28~2015/8/14	Relative Humidity:	52~53	%

TEST RESULTS DATA
6dB and 99% Occupied Bandwidth

2.4GHz Band										
Mod.	Data Rate	NTX	CH.	Freq. (MHz)			6dB BW (MHz)		6dB BW Limit (MHz)	Pass/Fail
							Ant 1	Ant 2		
11b	1Mbps	1	1	2412			8.08	8.04	0.50	Pass
11b	1Mbps	1	6	2437			8.08	8.00	0.50	Pass
11b	1Mbps	1	11	2462			7.56	8.04	0.50	Pass
11b	1Mbps	1	12	2467			7.56	8.04	0.50	Pass
11b	1Mbps	1	13	2472			8.04	8.00	0.50	Pass
11g	6Mbps	2	1	2412			16.46	16.40	0.50	Pass
11g	6Mbps	2	6	2437			16.40	16.36	0.50	Pass
11g	6Mbps	2	11	2462			15.76	16.40	0.50	Pass
11g	6Mbps	2	12	2467			16.40	16.40	0.50	Pass
11g	6Mbps	2	13	2472			16.40	16.36	0.50	Pass
HT20	MCS8	2	1	2412			17.38	17.68	0.50	Pass
HT20	MCS8	2	6	2437			17.72	17.64	0.50	Pass
HT20	MCS8	2	11	2462			16.96	17.68	0.50	Pass
HT20	MCS8	2	12	2467			17.60	17.66	0.50	Pass
HT20	MCS8	2	13	2472			17.64	17.60	0.50	Pass

TEST RESULTS DATA
Peak Output Power

2.4GHz Band																
Mod.	Data Rate	NTX	CH.	Freq. (MHz)	Peak Conducted Power (dBm)			Conducted Power Limit (dBm)		DG (dBi)		EIRP Power (dBm)		EIRP Power Limit (dBm)		Pass /Fail
					Ant 1	Ant 2	SUM	Ant 1	Ant 2	Ant 1	Ant 2	Ant 1	Ant 2	Ant 1	Ant 2	
11b	1Mbps	1	1	2412	16.92	16.60		30.00	30.00	-1.60	-4.10	15.32	12.50	36.00	36.00	Pass
11b	1Mbps	1	6	2437	16.78	16.56		30.00	30.00	-1.60	-4.10	15.18	12.46	36.00	36.00	Pass
11b	1Mbps	1	11	2462	16.68	16.92		30.00	30.00	-1.60	-4.10	15.08	12.82	36.00	36.00	Pass
11b	1Mbps	1	12	2467	17.00	16.81		30.00	30.00	-1.60	-4.10	15.40	12.71	36.00	36.00	Pass
11b	1Mbps	1	13	2472	15.75	15.32		30.00	30.00	-1.60	-4.10	14.15	11.22	36.00	36.00	Pass
11g	1Mbps	2	1	2412	20.45	20.40	23.44	30.00		0.25		23.69		36.00		Pass
11g	1Mbps	2	6	2437	20.35	20.32	23.35	30.00		0.25		23.60		36.00		Pass
11g	1Mbps	2	11	2462	20.39	20.28	23.35	30.00		0.25		23.60		36.00		Pass
11g	Data Rat	2	12	2467	17.67	15.52	19.74	30.00		0.25		19.99		36.00		Pass
11g	Data Rat	2	13	2472	10.67	9.79	13.26	30.00		0.25		13.51		36.00		Pass
HT20	MCS8	2	1	2412	20.32	20.30	23.32	30.00		0.25		23.57		36.00		Pass
HT20	MCS8	2	6	2437	20.48	20.56	23.53	30.00		0.25		23.78		36.00		Pass
HT20	MCS8	2	11	2462	20.23	20.14	23.20	30.00		0.25		23.45		36.00		Pass
HT20	MCS8	2	12	2467	15.67	14.09	17.96	30.00		0.25		18.21		36.00		Pass
HT20	MCS8	2	13	2472	10.18	8.62	12.48	30.00		0.25		12.73		36.00		Pass

Note: Measured power (dBm) has offset with cable loss.

TEST RESULTS DATA
Average Output Power

2.4GHz Band									
Mod.	Data Rate	NTX	CH.	Freq. (MHz)	Duty Factor (dB)		Average Conducted Power (dBm)		
					Ant 1	Ant 2	Ant 1	Ant 2	SUM
11b	1Mbps	1	1	2412	0.04	0.04	13.66	13.64	
11b	1Mbps	1	6	2437	0.04	0.04	13.58	13.56	
11b	1Mbps	1	11	2462	0.04	0.04	13.60	13.78	
11b	1Mbps	1	12	2467	0.04	0.04	13.76	13.74	
11b	1Mbps	1	13	2472	0.04	0.04	12.49	12.18	
11g	6Mbps	2	1	2412	0.00	0.00	13.79	13.74	16.78
11g	Data Rat	2	6	2437	0.00	0.00	13.66	13.71	16.70
11g	6Mbps	2	11	2462	0.00	0.00	13.62	13.79	16.72
11g	Data Rat	2	12	2467	0.00	0.00	10.35	8.81	12.66
11g	Data Rat	2	13	2472	0.00	0.00	3.66	2.28	6.03
HT20	MCS8	2	1	2412	0.00	0.00	13.58	13.64	16.62
HT20	MCS8	2	6	2437	0.00	0.00	13.61	13.75	16.69
HT20	MCS8	2	11	2462	0.00	0.00	13.63	13.60	16.63
HT20	MCS8	2	12	2467	0.00	0.00	8.23	7.05	10.69
HT20	MCS8	2	13	2472	0.00	0.00	3.19	1.64	5.49

Note: Measured power (dBm) has offset with cable loss.

TEST RESULTS DATA
Peak Power Spectral Density

2.4GHz Band												
Mod.	Data Rate	NTX	CH.	Freq. (MHz)	Peak PSD (dBm/3kHz)			DG (dBi)		Peak PSD Limit (dBm/3kHz)		Pass/Fail
					Ant 1	Ant 2	Worse + 3.01	Ant 1	Ant 2	Ant 1	Ant 2	
11b	1Mbps	1	1	2412	-7.50	-8.62		-1.60	-4.10	8.00	8.00	Pass
11b	1Mbps	1	6	2437	-8.66	-8.27		-1.60	-4.10	8.00	8.00	Pass
11b	1Mbps	1	11	2462	-8.66	-8.63		-1.60	-4.10	8.00	8.00	Pass
11b	1Mbps	1	12	2467	-8.39	-8.64		-1.60	-4.10	8.00	8.00	Pass
11b	1Mbps	1	13	2472	-9.00	-10.07		-1.60	-4.10	8.00	8.00	Pass
11g	6Mbps	2	1	2412	-11.64	-11.73	-8.63	0.25		8.00		Pass
11g	6Mbps	2	6	2437	-11.31	-11.89	-8.30	0.25		8.00		Pass
11g	6Mbps	2	11	2462	-10.67	-11.10	-7.66	0.25		8.00		Pass
11g	6Mbps	2	12	2467	-14.00	-15.48	-10.99	0.25		8.00		Pass
11g	6Mbps	2	13	2472	-21.78	-22.95	-18.77	0.25		8.00		Pass
HT20	MCS8	2	1	2412	-11.65	-12.27	-8.64	0.25		8.00		Pass
HT20	MCS8	2	6	2437	-11.58	-12.18	-8.57	0.25		8.00		Pass
HT20	MCS8	2	11	2462	-11.61	-12.31	-8.60	0.25		8.00		Pass
HT20	MCS8	2	12	2467	-16.62	-18.61	-13.61	0.25		8.00		Pass
HT20	MCS8	2	13	2472	-22.63	-23.90	-19.62	0.25		8.00		Pass

Measured power density (dBm) has offset with cable loss.



Appendix B. Radiated Spurious Emission

Test Engineer :	Nick Yu and James Chiu	Temperature :	22~24°C
		Relative Humidity :	55~58%

15C 2.4GHz 2400~2483.5MHz

WIFI 802.11b (Band Edge @ 3m)

WIFI	Note	Frequency	Level	Over	Limit	Read	Antenna	Cable	Preamp	Ant	Table	Peak	Pol.	
Ant.				Limit	Line	Level	Factor	Loss	Factor	Pos	Pos	Avg.		
1		(MHz)	(dBμV/m)	(dB)	(dBμV/m)	(dBμV)	(dB/m)	(dB)	(dB)	(cm)	(deg)	(P/A)	(H/V)	
802.11b CH 01 2412MHz		2389.83	54.34	-19.66	74	55.14	27.23	6.01	34.04	263	24	P	H	
		2390	44.09	-9.91	54	44.89	27.23	6.01	34.04	263	24	A	H	
	*	2413.19	105	-	-	105.72	27.28	6.04	34.04	263	24	P	H	
	*	2413.11	102.49	-	-	103.21	27.28	6.04	34.04	263	24	A	H	
													H	
													H	
			2371.29	53.85	-20.15	74	54.69	27.19	6.01	34.04	100	110	P	V
			2390	41.7	-12.3	54	42.5	27.23	6.01	34.04	100	110	A	V
	*		2413.19	94.52	-	-	95.24	27.28	6.04	34.04	100	110	P	V
	*		2413.44	91.84	-	-	92.56	27.28	6.04	34.04	100	110	A	V
													V	
													V	
802.11b CH 06 2437MHz		2390	53.14	-20.86	74	53.94	27.23	6.01	34.04	259	27	P	H	
		2390	43.08	-10.92	54	43.88	27.23	6.01	34.04	259	27	A	H	
	*	2438.24	105.42	-	-	106.04	27.37	6.04	34.03	259	27	P	H	
	*	2438.08	102.89	-	-	103.51	27.37	6.04	34.03	259	27	A	H	
			2485.12	52.93	-21.07	74	53.39	27.46	6.09	34.01	259	27	P	H
			2483.52	42.94	-11.06	54	43.4	27.46	6.09	34.01	259	27	A	H
			2346.63	53.08	-20.92	74	54.08	27.1	5.95	34.05	399	136	P	V
			2389.74	41.62	-12.38	54	42.42	27.23	6.01	34.04	399	136	A	V
	*		2435.91	93.59	-	-	94.26	27.32	6.04	34.03	399	136	P	V
	*		2435.91	91.09	-	-	91.76	27.32	6.04	34.03	399	136	A	V
			2491.04	52.72	-21.28	74	53.14	27.5	6.09	34.01	399	136	P	V
			2494.56	41.93	-12.07	54	42.34	27.5	6.09	34	399	136	A	V



802.11b CH 11 2462MHz	*	2460.87	105.48	-	-	106.02	27.41	6.07	34.02	256	24	P	H
	*	2460.87	103.01	-	-	103.55	27.41	6.07	34.02	256	24	A	H
		2483.56	54.83	-19.17	74	55.29	27.46	6.09	34.01	256	24	P	H
		2483.52	44.08	-9.92	54	44.54	27.46	6.09	34.01	256	24	A	H
													H
													H
	*	2460.79	95.65	-	-	96.19	27.41	6.07	34.02	352	94	P	V
	*	2460.87	93.23	-	-	93.77	27.41	6.07	34.02	352	94	A	V
		2483.56	52.54	-21.46	74	53	27.46	6.09	34.01	352	94	P	V
		2483.52	41.97	-12.03	54	42.43	27.46	6.09	34.01	352	94	A	V
												V	
												V	
802.11b CH 12 2467MHz	*	2467	103.77	-	-	104.3	27.41	6.07	34.01	268	18	P	H
	*	2467	101.25	-	-	101.78	27.41	6.07	34.01	268	18	A	H
		2483.64	58.13	-15.87	74	58.59	27.46	6.09	34.01	268	18	P	H
		2483.52	46.79	-7.21	54	47.25	27.46	6.09	34.01	268	18	A	H
													H
													H
	*	2467	96.42	-	-	96.95	27.41	6.07	34.01	391	61	P	V
	*	2467	93.91	-	-	94.44	27.41	6.07	34.01	391	61	A	V
		2490.72	52.76	-21.24	74	53.18	27.5	6.09	34.01	391	61	P	V
		2483.52	42.84	-11.16	54	43.3	27.46	6.09	34.01	391	61	A	V
												V	
												V	



802.11b CH 13 2472MHz	*	2472	104.26	-	-	104.74	27.46	6.07	34.01	260	22	P	H
	*	2472	101.76	-	-	102.24	27.46	6.07	34.01	260	22	A	H
		2483.64	60.65	-13.35	74	61.11	27.46	6.09	34.01	260	22	P	H
		2485.92	48.16	-5.84	54	48.62	27.46	6.09	34.01	260	22	A	H
													H
													H
	*	2472	93.94	-	-	94.42	27.46	6.07	34.01	352	59	P	V
	*	2472	91.43	-	-	91.91	27.46	6.07	34.01	352	59	A	V
		2485.28	53.37	-20.63	74	53.83	27.46	6.09	34.01	352	59	P	V
		2485.96	42.59	-11.41	54	43.05	27.46	6.09	34.01	352	59	A	V
													V
													V
Remark	1. No other spurious found. 2. All results are PASS against Peak and Average limit line.												



15C 2.4GHz 2400~2483.5MHz

WIFI 802.11b (Harmonic @ 3m)

WIFI	Note	Frequency	Level	Over	Limit	Read	Antenna	Cable	Preamp	Ant	Table	Peak	Pol.
Ant.				Limit	Line	Level	Factor	Loss	Factor	Pos	Pos	Avg.	
1		(MHz)	(dBμV/m)	(dB)	(dBμV/m)	(dBμV)	(dB/m)	(dB)	(dB)	(cm)	(deg)	(P/A)	(H/V)
802.11b CH 01 2412MHz		4824	39.24	-34.76	74	64.34	31.32	8.65	65.07	100	0	P	H
													H
													H
													H
		4824	38.58	-35.42	74	63.68	31.32	8.65	65.07	100	0	P	V
													V
													V
													V
802.11b CH 06 2437MHz		4872	37.89	-36.11	74	62.81	31.41	8.69	65.02	100	0	P	H
		7308	41.28	-32.72	74	59.67	36.28	10.39	65.06	100	0	P	H
													H
													H
		4872	38.45	-35.55	74	63.37	31.41	8.69	65.02	100	0	P	V
		7308	41.23	-32.77	74	59.62	36.28	10.39	65.06	100	0	P	V
													V
													V
802.11b CH 11 2462MHz		4926	36.87	-37.13	74	61.56	31.49	8.79	64.97	100	0	P	H
		7386	42.16	-31.84	74	60.29	36.47	10.48	65.08	100	0	P	H
													H
													H
		4926	38.21	-35.79	74	62.9	31.49	8.79	64.97	100	0	P	V
		7386	41.49	-32.51	74	59.62	36.47	10.48	65.08	100	0	P	V
													V
													V
Remark	1. No other spurious found. 2. All results are PASS against Peak and Average limit line.												



802.11b CH 12 2467MHz		4932	37.48	-36.52	74	62.17	31.49	8.79	64.97	100	0	P	H
		7404	42.62	-31.38	74	60.67	36.51	10.52	65.08	100	0	P	H
													H
													H
		4932	37.23	-36.77	74	61.92	31.49	8.79	64.97	100	0	P	V
		7404	41.54	-32.46	74	59.59	36.51	10.52	65.08	100	0	P	V
													V
													V
802.11b CH 13 2472MHz		4944	37.28	-36.72	74	61.92	31.52	8.79	64.95	100	0	P	H
		7416	41.52	-32.48	74	59.57	36.51	10.52	65.08	100	0	P	H
													H
													H
		4944	36.88	-37.12	74	61.52	31.52	8.79	64.95	100	0	P	V
		7416	41.52	-32.48	74	59.57	36.51	10.52	65.08	100	0	P	V
													V
													V
Remark	1. No other spurious found. 2. All results are PASS against Peak and Average limit line.												



15C Emission below 1GHz
2.4GHz WIFI 802.11b (LF)

WIFI	Note	Frequency	Level	Over	Limit	Read	Antenna	Cable	Preamp	Ant	Table	Peak	Pol.	
Ant.				Limit	Line	Level	Factor	Loss	Factor	Pos	Pos	Avg.		
1		(MHz)	(dBμV/m)	(dB)	(dBμV/m)	(dBμV)	(dB/m)	(dB)	(dB)	(cm)	(deg)	(P/A)	(H/V)	
2.4GHz 802.11b LF		30.81	15.85	-24.15	40	29.41	17.6	0.67	31.83	-	-	P	H	
		64.83	16.36	-23.64	40	42.21	4.9	1.04	31.79	-	-	P	H	
		170.13	17.85	-25.65	43.5	39.2	8.79	1.64	31.78	-	-	P	H	
		392.4	27.19	-18.81	46	41.35	15.32	2.32	31.8	104	37	P	H	
		531	22.57	-23.43	46	33.87	17.87	2.77	31.94	-	-	P	H	
		951	23.07	-22.93	46	29.84	20.58	3.68	31.03	-	-	P	H	
														H
														H
														H
														H
														H
														H
			32.7	24.96	-15.04	40	39.47	16.65	0.67	31.83	-	-	P	V
			58.62	29.97	-10.03	40	55.32	5.41	1.04	31.8	118	62	P	V
			64.83	20.68	-19.32	40	46.53	4.9	1.04	31.79	-	-	P	V
			600.3	22.69	-23.31	46	33.43	18.41	2.89	32.04	-	-	P	V
			652.1	25.51	-20.49	46	35.45	19.08	3.02	32.04	-	-	P	V
			916.7	22.55	-23.45	46	30.13	20.17	3.55	31.3	-	-	P	V
														V
														V
													V	
													V	
													V	
													V	
Remark	1. No other spurious found. 2. All results are PASS against limit line.													



Note symbol

*	Fundamental Frequency which can be ignored. However, the level of any unwanted emissions shall not exceed the level of the fundamental frequency per 15.209(c).
!	Test result is over limit line.
P/A	Peak or Average
H/V	Horizontal or Vertical



A calculation example for radiated spurious emission is shown as below:

WIFI	Note	Frequency	Level	Over	Limit	Read	Antenna	Cable	Preamp	Ant	Table	Peak	Pol.
Ant.				Limit	Line	Level	Factor	Loss	Factor	Pos	Pos	Avg.	
1+2		(MHz)	(dBμV/m)	(dB)	(dBμV/m)	(dBμV)	(dB/m)	(dB)	(dB)	(cm)	(deg)	(P/A)	(H/V)
802.11b		2390	55.45	-18.55	74	54.51	32.22	4.58	35.86	103	308	P	H
CH 01													
2412MHz		2390	43.54	-10.46	54	42.6	32.22	4.58	35.86	103	308	A	H

- Level(dBμV/m) =
Antenna Factor(dB/m) + Cable Loss(dB) + Read Level(dBμV) - Preamp Factor(dB)
- Over Limit(dB) = Level(dBμV/m) – Limit Line(dBμV/m)

For Peak Limit @ 2390MHz:

- Level(dBμV/m)
= Antenna Factor(dB/m) + Cable Loss(dB) + Read Level(dBμV) - Preamp Factor(dB)
= 32.22(dB/m) + 4.58(dB) + 54.51(dBμV) – 35.86 (dB)
= 55.45 (dBμV/m)
- Over Limit(dB)
= Level(dBμV/m) – Limit Line(dBμV/m)
= 55.45(dBμV/m) – 74(dBμV/m)
= -18.55(dB)

For Average Limit @ 2390MHz:

- Level(dBμV/m)
= Antenna Factor(dB/m) + Cable Loss(dB) + Read Level(dBμV) - Preamp Factor(dB)
= 32.22(dB/m) + 4.58(dB) + 42.6(dBμV) – 35.86 (dB)
= 43.54 (dBμV/m)
- Over Limit(dB)
= Level(dBμV/m) – Limit Line(dBμV/m)
= 43.54(dBμV/m) – 54(dBμV/m)
= -10.46(dB)

Both peak and average measured complies with the limit line, so test result is “PASS”.



15C 2.4GHz 2400~2483.5MHz
WIFI 802.11b (Band Edge @ 3m)

WIFI	Note	Frequency	Level	Over	Limit	Read	Antenna	Cable	Preamp	Ant	Table	Peak	Pol.	
Ant.				Limit	Line	Level	Factor	Loss	Factor	Pos	Pos	Avg.		
2		(MHz)	(dBμV/m)	(dB)	(dBμV/m)	(dBμV)	(dB/m)	(dB)	(dB)	(cm)	(deg)	(P/A)	(H/V)	
802.11b CH 01 2412MHz		2389.2	52.39	-21.61	74	53.19	27.23	6.01	34.04	112	54	P	H	
		2390	42.56	-11.44	54	43.36	27.23	6.01	34.04	112	54	A	H	
	*	2412	97.99	-	-	98.71	27.28	6.04	34.04	112	54	P	H	
	*	2412	95.48	-	-	96.2	27.28	6.04	34.04	112	54	A	H	
													H	
													H	
			2389.74	54.04	-19.96	74	54.84	27.23	6.01	34.04	318	81	P	V
			2390	43.43	-10.57	54	44.23	27.23	6.01	34.04	318	81	A	V
	*		2412	101.45	-	-	102.17	27.28	6.04	34.04	318	81	P	V
	*		2412	98.98	-	-	99.7	27.28	6.04	34.04	318	81	A	V
													V	
													V	
802.11b CH 06 2437MHz		2366.88	53.02	-20.98	74	53.91	27.14	6.01	34.04	100	58	P	H	
		2388.75	41.84	-12.16	54	42.64	27.23	6.01	34.04	100	58	A	H	
	*	2437	99.21	-	-	99.83	27.37	6.04	34.03	100	58	P	H	
	*	2437	96.68	-	-	97.3	27.37	6.04	34.03	100	58	A	H	
			2494.56	52.44	-21.56	74	52.85	27.5	6.09	34	100	58	P	H
			2483.72	42.24	-11.76	54	42.7	27.46	6.09	34.01	100	58	A	H
			2389.2	54.1	-19.9	74	54.9	27.23	6.01	34.04	317	82	P	V
			2390	41.77	-12.23	54	42.57	27.23	6.01	34.04	317	82	A	V
	*		2437	102.94	-	-	103.56	27.37	6.04	34.03	317	82	P	V
	*		2437	100.3	-	-	100.92	27.37	6.04	34.03	317	82	A	V
			2493.4	52.81	-21.19	74	53.22	27.5	6.09	34	317	82	P	V
			2483.56	42.23	-11.77	54	42.69	27.46	6.09	34.01	317	82	A	V



802.11b CH 11 2462MHz	*	2462	99.82	-	-	100.36	27.41	6.07	34.02	100	55	P	H
	*	2462	97.18	-	-	97.72	27.41	6.07	34.02	100	55	A	H
		2484.2	52.66	-21.34	74	53.12	27.46	6.09	34.01	100	55	P	H
		2483.52	42.83	-11.17	54	43.29	27.46	6.09	34.01	100	55	A	H
													H
													H
	*	2462	101.34	-	-	101.88	27.41	6.07	34.02	323	93	P	V
	*	2462	98.52	-	-	99.06	27.41	6.07	34.02	323	93	A	V
		2487	53.15	-20.85	74	53.61	27.46	6.09	34.01	323	93	P	V
		2483.52	43.24	-10.76	54	43.7	27.46	6.09	34.01	323	93	A	V
												V	
												V	
802.11b CH 12 2467MHz	*	2467	101.33	-	-	101.86	27.41	6.07	34.01	162	144	P	H
	*	2467	98.9	-	-	99.43	27.41	6.07	34.01	162	144	A	H
		2483.72	54.79	-19.21	74	55.25	27.46	6.09	34.01	162	144	P	H
		2483.52	46.12	-7.88	54	46.58	27.46	6.09	34.01	162	144	A	H
													H
													H
	*	2467	100.39	-	-	100.92	27.41	6.07	34.01	288	73	P	V
	*	2467	97.87	-	-	98.4	27.41	6.07	34.01	288	73	A	V
		2483.68	54.8	-19.2	74	55.26	27.46	6.09	34.01	288	73	P	V
		2483.52	45.85	-8.15	54	46.31	27.46	6.09	34.01	288	73	A	V
												V	
												V	



802.11b CH 13 2472MHz	*	2472	95.78	-	-	96.26	27.46	6.07	34.01	104	42	P	H
	*	2472	92.91	-	-	93.39	27.46	6.07	34.01	104	42	A	H
		2485.6	54.74	-19.26	74	55.2	27.46	6.09	34.01	104	42	P	H
		2485.44	45.99	-8.01	54	46.45	27.46	6.09	34.01	104	42	A	H
													H
													H
	*	2472	100.95	-	-	101.43	27.46	6.07	34.01	282	67	P	V
	*	2472	98.48	-	-	98.96	27.46	6.07	34.01	282	67	A	V
		2484.84	56.8	-17.2	74	57.26	27.46	6.09	34.01	282	67	P	V
		2485.52	49.72	-4.28	54	50.18	27.46	6.09	34.01	282	67	A	V
													V
													V
Remark	1. No other spurious found. 2. All results are PASS against Peak and Average limit line.												



15C 2.4GHz 2400~2483.5MHz

WIFI 802.11b (Harmonic @ 3m)

WIFI	Note	Frequency	Level	Over	Limit	Read	Antenna	Cable	Preamp	Ant	Table	Peak	Pol.	
Ant.				Limit	Line	Level	Factor	Loss	Factor	Pos	Pos	Avg.		
2		(MHz)	(dBμV/m)	(dB)	(dBμV/m)	(dBμV)	(dB/m)	(dB)	(dB)	(cm)	(deg)	(P/A)	(H/V)	
802.11b CH 01 2412MHz		4824	38.54	-35.46	74	63.64	31.32	8.65	65.07	100	0	P	H	
													H	
													H	
													H	
		4824	36.4	-37.6	74	61.5	31.32	8.65	65.07	100	0	P	V	
														V
														V
														V
802.11b CH 06 2437MHz		4872	36.48	-37.52	74	61.4	31.41	8.69	65.02	100	0	P	H	
		7308	41.25	-32.75	74	59.64	36.28	10.39	65.06	100	0	P	H	
													H	
													H	
		4872	36.81	-37.19	74	61.73	31.41	8.69	65.02	100	0	P	V	
		7308	41.14	-32.86	74	59.53	36.28	10.39	65.06	100	0	P	V	
														V
														V
802.11b CH 11 2462MHz		4926	37.16	-36.84	74	61.85	31.49	8.79	64.97	100	0	P	H	
		7386	41.36	-32.64	74	59.49	36.47	10.48	65.08	100	0	P	H	
													H	
													H	
		4926	37.53	-36.47	74	62.22	31.49	8.79	64.97	100	0	P	V	
		7386	41.58	-32.42	74	59.71	36.47	10.48	65.08	100	0	P	V	
														V
														V



802.11b CH 12 2467MHz		4932	37.49	-36.51	74	62.18	31.49	8.79	64.97	100	0	P	H
		7404	40.96	-33.04	74	59.01	36.51	10.52	65.08	100	0	P	H
													H
													H
		4932	36.71	-37.29	74	61.4	31.49	8.79	64.97	100	0	P	V
		7404	41.75	-32.25	74	59.8	36.51	10.52	65.08	100	0	P	V
													V
													V
802.11b CH 13 2472MHz		4932	37.54	-36.46	74	62.23	31.49	8.79	64.97	100	0	P	H
		7404	41.85	-32.15	74	59.9	36.51	10.52	65.08	100	0	P	H
													H
													H
		4932	37.56	-36.44	74	62.25	31.49	8.79	64.97	100	0	P	V
		7404	42.05	-31.95	74	60.1	36.51	10.52	65.08	100	0	P	V
													V
													V
Remark	1. No other spurious found. 2. All results are PASS against Peak and Average limit line.												



**15C Emission below 1GHz
2.4GHz WIFI 802.11b (LF)**

WIFI	Note	Frequency	Level	Over	Limit	Read	Antenna	Cable	Preamp	Ant	Table	Peak	Pol.	
Ant.				Limit	Line	Level	Factor	Loss	Factor	Pos	Pos	Avg.		
2		(MHz)	(dBμV/m)	(dB)	(dBμV/m)	(dBμV)	(dB/m)	(dB)	(dB)	(cm)	(deg)	(P/A)	(H/V)	
2.4GHz 802.11b LF		31.89	15.8	-24.2	40	29.9	17.06	0.67	31.83	-	-	P	H	
		100.74	18.32	-25.18	43.5	38.6	10.22	1.28	31.78	-	-	P	H	
		192.54	22.21	-21.29	43.5	44	8.35	1.64	31.78	104	38	P	H	
		548.5	23.56	-22.44	46	34.08	18.67	2.77	31.96	-	-	P	H	
		666.8	23.78	-22.22	46	33.87	18.93	3.02	32.04	-	-	P	H	
		939.8	22.95	-23.05	46	29.89	20.49	3.68	31.11	-	-	P	H	
														H
														H
														H
														H
														H
														H
			30	21.39	-18.61	40	34.55	18	0.67	31.83	-	-	P	V
			68.61	21.26	-18.74	40	46.95	5.06	1.04	31.79	-	-	P	V
			102.09	26.43	-17.07	43.5	46.5	10.43	1.28	31.78	123	39	P	V
			654.9	21.75	-24.25	46	31.72	19.05	3.02	32.04	-	-	P	V
			920.9	23.34	-22.66	46	30.85	20.2	3.55	31.26	-	-	P	V
			929.3	23.16	-22.84	46	30.48	20.2	3.68	31.2	-	-	P	V
													V	
													V	
													V	
													V	
													V	
													V	
Remark	1. No other spurious found. 2. All results are PASS against limit line.													



Note symbol

*	Fundamental Frequency which can be ignored. However, the level of any unwanted emissions shall not exceed the level of the fundamental frequency per 15.209(c).
!	Test result is over limit line.
P/A	Peak or Average
H/V	Horizontal or Vertical



A calculation example for radiated spurious emission is shown as below:

WIFI	Note	Frequency	Level	Over	Limit	Read	Antenna	Cable	Preamp	Ant	Table	Peak	Pol.
Ant.				Limit	Line	Level	Factor	Loss	Factor	Pos	Pos	Avg.	
1+2		(MHz)	(dBμV/m)	(dB)	(dBμV/m)	(dBμV)	(dB/m)	(dB)	(dB)	(cm)	(deg)	(P/A)	(H/V)
802.11b		2390	55.45	-18.55	74	54.51	32.22	4.58	35.86	103	308	P	H
CH 01													
2412MHz		2390	43.54	-10.46	54	42.6	32.22	4.58	35.86	103	308	A	H

- Level(dBμV/m) =
Antenna Factor(dB/m) + Cable Loss(dB) + Read Level(dBμV) - Preamp Factor(dB)
- Over Limit(dB) = Level(dBμV/m) – Limit Line(dBμV/m)

For Peak Limit @ 2390MHz:

- Level(dBμV/m)
= Antenna Factor(dB/m) + Cable Loss(dB) + Read Level(dBμV) - Preamp Factor(dB)
= 32.22(dB/m) + 4.58(dB) + 54.51(dBμV) – 35.86 (dB)
= 55.45 (dBμV/m)
- Over Limit(dB)
= Level(dBμV/m) – Limit Line(dBμV/m)
= 55.45(dBμV/m) – 74(dBμV/m)
= -18.55(dB)

For Average Limit @ 2390MHz:

- Level(dBμV/m)
= Antenna Factor(dB/m) + Cable Loss(dB) + Read Level(dBμV) - Preamp Factor(dB)
= 32.22(dB/m) + 4.58(dB) + 42.6(dBμV) – 35.86 (dB)
= 43.54 (dBμV/m)
- Over Limit(dB)
= Level(dBμV/m) – Limit Line(dBμV/m)
= 43.54(dBμV/m) – 54(dBμV/m)
= -10.46(dB)

Both peak and average measured complies with the limit line, so test result is “PASS”.



15C 2.4GHz 2400~2483.5MHz

WIFI 802.11g (Band Edge @ 3m)

WIFI	Note	Frequency	Level	Over	Limit	Read	Antenna	Cable	Preamp	Ant	Table	Peak	Pol.	
Ant.				Limit	Line	Level	Factor	Loss	Factor	Pos	Pos	Avg.		
1+2		(MHz)	(dBμV/m)	(dB)	(dBμV/m)	(dBμV)	(dB/m)	(dB)	(dB)	(cm)	(deg)	(P/A)	(H/V)	
802.11g CH 01 2412MHz		2389	59.43	-14.57	74	60.23	27.23	6.01	34.04	159	168	P	H	
		2389	48.81	-5.19	54	49.61	27.23	6.01	34.04	159	168	A	H	
	*	2412	107.06	-	-	107.78	27.28	6.04	34.04	159	168	P	H	
	*	2412	99.58	-	-	100.3	27.28	6.04	34.04	159	168	A	H	
													H	
														H
			2389.56	59.51	-14.49	74	60.31	27.23	6.01	34.04	100	264	P	V
			2390	47.28	-6.72	54	48.08	27.23	6.01	34.04	100	264	A	V
	*		2412	101.9	-	-	102.62	27.28	6.04	34.04	100	264	P	V
	*		2412	94.13	-	-	94.85	27.28	6.04	34.04	100	264	A	V
														V
														V
802.11g CH 06 2437MHz		2388.84	54.67	-19.33	74	55.47	27.23	6.01	34.04	131	169	P	H	
		2390	44.15	-9.85	54	44.95	27.23	6.01	34.04	131	169	A	H	
	*	2437	106.24	-	-	106.86	27.37	6.04	34.03	131	169	P	H	
	*	2437	98.82	-	-	99.44	27.37	6.04	34.03	131	169	A	H	
			2497.96	53.56	-20.44	74	53.97	27.5	6.09	34	131	169	P	H
			2483.68	43.22	-10.78	54	43.68	27.46	6.09	34.01	131	169	A	H
			2338.17	53.04	-20.96	74	54.05	27.1	5.95	34.06	202	98	P	V
			2389.83	42.17	-11.83	54	42.97	27.23	6.01	34.04	202	98	A	V
	*		2437	103	-	-	103.62	27.37	6.04	34.03	202	98	P	V
	*		2437	95.42	-	-	96.04	27.37	6.04	34.03	202	98	A	V
			2483.76	53.24	-20.76	74	53.7	27.46	6.09	34.01	202	98	P	V
			2483.52	42.51	-11.49	54	42.97	27.46	6.09	34.01	202	98	A	V



802.11g CH 11 2462MHz	*	2462	107.53	-	-	108.07	27.41	6.07	34.02	292	23	P	H
	*	2462	99.91	-	-	100.45	27.41	6.07	34.02	292	23	A	H
		2484.2	57.48	-16.52	74	57.94	27.46	6.09	34.01	292	23	P	H
		2483.6	46.36	-7.64	54	46.82	27.46	6.09	34.01	292	23	A	H
													H
													H
	*	2462	101.95	-	-	102.49	27.41	6.07	34.02	117	161	P	V
	*	2462	93.27	-	-	93.81	27.41	6.07	34.02	117	161	A	V
		2483.72	59.19	-14.81	74	59.65	27.46	6.09	34.01	117	161	P	V
		2483.52	46.93	-7.07	54	47.39	27.46	6.09	34.01	117	161	A	V
													V
													V
802.11g CH 12 2467MHz	*	2467	103.11	-	-	103.64	27.41	6.07	34.01	294	35	P	H
	*	2467	95.51	-	-	96.04	27.41	6.07	34.01	294	35	A	H
		2484.92	54.82	-19.18	74	55.28	27.46	6.09	34.01	294	35	P	H
		2485.24	44.5	-9.5	54	44.96	27.46	6.09	34.01	294	35	A	H
													H
													H
	*	2467	98.12	-	-	98.65	27.41	6.07	34.01	100	265	P	V
	*	2467	90.28	-	-	90.81	27.41	6.07	34.01	100	265	A	V
		2483.64	54.95	-19.05	74	55.41	27.46	6.09	34.01	100	265	P	V
		2483.72	44.41	-9.59	54	44.87	27.46	6.09	34.01	100	265	A	V
													V
													V



802.11g CH 13 2472MHz	*	2472	96.19	-	-	96.67	27.46	6.07	34.01	254	28	P	H
	*	2472	88.61	-	-	89.09	27.46	6.07	34.01	254	28	A	H
		2483.56	62.15	-11.85	74	62.61	27.46	6.09	34.01	254	28	P	H
		2483.52	50.83	-3.17	54	51.29	27.46	6.09	34.01	254	28	A	H
													H
													H
	*	2472	91.53	-	-	92.01	27.46	6.07	34.01	350	94	P	V
	*	2472	84.08	-	-	84.56	27.46	6.07	34.01	350	94	A	V
		2483.64	55.88	-18.12	74	56.34	27.46	6.09	34.01	350	94	P	V
		2483.52	44.27	-9.73	54	44.73	27.46	6.09	34.01	350	94	A	V
													V
													V
Remark	1. No other spurious found. 2. All results are PASS against Peak and Average limit line.												



15C 2.4GHz 2400~2483.5MHz

WIFI 802.11g (Harmonic @ 3m)

WIFI	Note	Frequency	Level	Over	Limit	Read	Antenna	Cable	Preamp	Ant	Table	Peak	Pol.
Ant.				Limit	Line	Level	Factor	Loss	Factor	Pos	Pos	Avg.	
1+2		(MHz)	(dBμV/m)	(dB)	(dBμV/m)	(dBμV)	(dB/m)	(dB)	(dB)	(cm)	(deg)	(P/A)	(H/V)
802.11g CH 01 2412MHz		4824	36.91	-37.09	74	62.01	31.32	8.65	65.07	100	0	P	H
													H
													H
													H
		4824	38.34	-35.66	74	63.44	31.32	8.65	65.07	100	0	P	V
													V
													V
													V
802.11g CH 06 2437MHz		4874	38.84	-35.16	74	63.76	31.41	8.69	65.02	100	0	P	H
		7311	41.68	-32.32	74	60.07	36.28	10.39	65.06	100	0	P	H
													H
													H
		4874	37.03	-36.97	74	61.95	31.41	8.69	65.02	100	0	P	V
		7311	41.2	-32.8	74	59.59	36.28	10.39	65.06	100	0	P	V
													V
													V
802.11g CH 11 2462MHz		4924	37.24	-36.76	74	61.93	31.49	8.79	64.97	100	0	P	H
		7386	41.38	-32.62	74	59.51	36.47	10.48	65.08	100	0	P	H
													H
													H
		4924	37.38	-36.62	74	62.07	31.49	8.79	64.97	100	0	P	V
		7386	41.64	-32.36	74	59.77	36.47	10.48	65.08	100	0	P	V
													V
													V



802.11g CH 12 2467MHz		4934	38.66	-35.34	74	63.35	31.49	8.79	64.97	100	0	P	H
		7401	41.21	-32.79	74	59.26	36.51	10.52	65.08	100	0	P	H
													H
													H
		4934	38.08	-35.92	74	62.77	31.49	8.79	64.97	100	0	P	V
		7401	41.79	-32.21	74	59.84	36.51	10.52	65.08	100	0	P	V
													V
													V
802.11g CH 13 2472MHz		4944	37.62	-36.38	74	62.26	31.52	8.79	64.95	100	0	P	H
		7416	41.59	-32.41	74	59.64	36.51	10.52	65.08	100	0	P	H
													H
													H
		4944	38.09	-35.91	74	62.73	31.52	8.79	64.95	100	0	P	V
		7416	41.86	-32.14	74	59.91	36.51	10.52	65.08	100	0	P	V
													V
													V
Remark	1. No other spurious found. 2. All results are PASS against Peak and Average limit line.												



15C 2.4GHz 2400~2483.5MHz

WIFI 802.11n HT20 (Band Edge @ 3m)

WIFI	Note	Frequency	Level	Over	Limit	Read	Antenna	Cable	Preamp	Ant	Table	Peak	Pol.	
Ant.				Limit	Line	Level	Factor	Loss	Factor	Pos	Pos	Avg.		
1+2		(MHz)	(dBμV/m)	(dB)	(dBμV/m)	(dBμV)	(dB/m)	(dB)	(dB)	(cm)	(deg)	(P/A)	(H/V)	
802.11n HT20 CH 01 2412MHz		2389.83	64.76	-9.24	74	65.56	27.23	6.01	34.04	160	142	P	H	
		2390	52.96	-1.04	54	53.76	27.23	6.01	34.04	160	142	A	H	
	*	2412	105.03	-	-	105.75	27.28	6.04	34.04	160	142	P	H	
	*	2412	97.54	-	-	98.26	27.28	6.04	34.04	160	142	A	H	
													H	
													H	
			2390	65.28	-8.72	74	66.08	27.23	6.01	34.04	263	143	P	V
			2390	51.92	-2.08	54	52.72	27.23	6.01	34.04	263	143	A	V
		*	2412	102.66	-	-	103.38	27.28	6.04	34.04	263	143	P	V
		*	2412	93.84	-	-	94.56	27.28	6.04	34.04	263	143	A	V
													V	
													V	
802.11n HT20 CH 06 2437MHz		2389.74	54.01	-19.99	74	54.81	27.23	6.01	34.04	257	20	P	H	
		2389.74	46.59	-7.41	54	47.39	27.23	6.01	34.04	257	20	A	H	
	*	2437	106.17	-	-	106.79	27.37	6.04	34.03	257	20	P	H	
	*	2437	99.14	-	-	99.76	27.37	6.04	34.03	257	20	A	H	
			2488.28	53.44	-20.56	74	53.86	27.5	6.09	34.01	257	20	P	H
			2483.52	45.77	-8.23	54	46.23	27.46	6.09	34.01	257	20	A	H
			2354.82	53.57	-20.43	74	54.53	27.14	5.95	34.05	354	114	P	V
			2387.04	44.54	-9.46	54	45.34	27.23	6.01	34.04	354	114	A	V
		*	2437	105.03	-	-	105.65	27.37	6.04	34.03	354	114	P	V
		*	2437	97.47	-	-	98.09	27.37	6.04	34.03	354	114	A	V
		2497.72	53.23	-20.77	74	53.64	27.5	6.09	34	354	114	P	V	
		2495.36	45.41	-8.59	54	45.82	27.5	6.09	34	354	114	A	V	



802.11n HT20 CH 11 2462MHz	*	2462	106.52	-	-	107.06	27.41	6.07	34.02	288	32	P	H
	*	2462	98.18	-	-	98.72	27.41	6.07	34.02	288	32	A	H
		2483.56	63.51	-10.49	74	63.97	27.46	6.09	34.01	288	32	P	H
		2483.52	50.52	-3.48	54	50.98	27.46	6.09	34.01	288	32	A	H
													H
													H
	*	2462	103.65	-	-	104.19	27.41	6.07	34.02	353	88	P	V
	*	2462	94.11	-	-	94.65	27.41	6.07	34.02	353	88	A	V
		2483.68	65.25	-8.75	74	65.71	27.46	6.09	34.01	353	88	P	V
		2483.52	51.92	-2.08	54	52.38	27.46	6.09	34.01	353	88	A	V
												V	
												V	
802.11n HT20 CH 12 2467MHz	*	2467	101.38	-	-	101.91	27.41	6.07	34.01	287	29	P	H
	*	2467	93.4	-	-	93.93	27.41	6.07	34.01	287	29	A	H
		2483.52	58.74	-15.26	74	59.2	27.46	6.09	34.01	287	29	P	H
		2483.52	48.61	-5.39	54	49.07	27.46	6.09	34.01	287	29	A	H
													H
													H
	*	2467	98.33	-	-	98.86	27.41	6.07	34.01	353	92	P	V
	*	2467	88.24	-	-	88.77	27.41	6.07	34.01	353	92	A	V
		2483.76	59.01	-14.99	74	59.47	27.46	6.09	34.01	353	92	P	V
		2483.52	47.45	-6.55	54	47.91	27.46	6.09	34.01	353	92	A	V
												V	
												V	



802.11n HT20 CH 13 2472MHz	*	2472	94.76	-	-	95.24	27.46	6.07	34.01	259	25	P	H
	*	2472	86.98	-	-	87.46	27.46	6.07	34.01	259	25	A	H
		2483.6	61.33	-12.67	74	61.79	27.46	6.09	34.01	259	25	P	H
		2483.52	50.2	-3.8	54	50.66	27.46	6.09	34.01	259	25	A	H
													H
													H
	*	2472	91.67	-	-	92.15	27.46	6.07	34.01	318	123	P	V
	*	2472	82.21	-	-	82.69	27.46	6.07	34.01	318	123	A	V
		2483.56	58.35	-15.65	74	58.81	27.46	6.09	34.01	318	123	P	V
		2483.52	46.01	-7.99	54	46.47	27.46	6.09	34.01	318	123	A	V
												V	
												V	
Remark	1. No other spurious found. 2. All results are PASS against Peak and Average limit line.												



15C 2.4GHz 2400~2483.5MHz

WIFI 802.11n HT20 (Harmonic @ 3m)

WIFI	Note	Frequency	Level	Over	Limit	Read	Antenna	Cable	Preamp	Ant	Table	Peak	Pol.	
Ant.				Limit	Line	Level	Factor	Loss	Factor	Pos	Pos	Avg.		
1+2		(MHz)	(dBμV/m)	(dB)	(dBμV/m)	(dBμV)	(dB/m)	(dB)	(dB)	(cm)	(deg)	(P/A)	(H/V)	
802.11n HT20 CH 01 2412MHz		4824	38.17	-35.83	74	63.27	31.32	8.65	65.07	100	0	P	H	
													H	
													H	
													H	
		4824	36.63	-37.37	74	61.73	31.32	8.65	65.07	100	0	P	V	
														V
														V
802.11n HT20 CH 06 2437MHz		4874	36.8	-37.2	74	61.72	31.41	8.69	65.02	100	0	P	H	
		7311	41.34	-32.66	74	59.73	36.28	10.39	65.06	100	0	P	H	
													H	
													H	
		4874	37.03	-36.97	74	61.95	31.41	8.69	65.02	100	0	P	V	
		7311	40.74	-33.26	74	59.13	36.28	10.39	65.06	100	0	P	V	
														V
802.11n HT20 CH 11 2462MHz		4924	36.53	-37.47	74	61.22	31.49	8.79	64.97	100	0	P	H	
		7386	42.16	-31.84	74	60.29	36.47	10.48	65.08	100	0	P	H	
													H	
													H	
		4924	36.87	-37.13	74	61.56	31.49	8.79	64.97	100	0	P	V	
		7386	41.57	-32.43	74	59.7	36.47	10.48	65.08	100	0	P	V	
														V



802.11n HT20 CH 12 2467MHz		4932	37.73	-36.27	74	62.42	31.49	8.79	64.97	100	0	P	H
		7404	41.16	-32.84	74	59.21	36.51	10.52	65.08	100	0	P	H
													H
													H
		4932	37.29	-36.71	74	61.98	31.49	8.79	64.97	100	0	P	V
		7404	41.52	-32.48	74	59.57	36.51	10.52	65.08	100	0	P	V
													V
													V
802.11n HT20 CH 13 2472MHz		4944	37.3	-36.7	74	61.94	31.52	8.79	64.95	100	0	P	H
		7416	42.52	-31.48	74	60.57	36.51	10.52	65.08	100	0	P	H
													H
													H
		4944	38.2	-35.8	74	62.84	31.52	8.79	64.95	100	0	P	V
		7416	42.66	-31.34	74	60.71	36.51	10.52	65.08	100	0	P	V
													V
													V
Remark	1. No other spurious found. 2. All results are PASS against Peak and Average limit line.												



15C Emission below 1GHz

2.4GHz WIFI 802.11g (LF)

WIFI	Note	Frequency	Level	Over	Limit	Read	Antenna	Cable	Preamp	Ant	Table	Peak	Pol.	
Ant.				Limit	Line	Level	Factor	Loss	Factor	Pos	Pos	Avg.		
1+2		(MHz)	(dBμV/m)	(dB)	(dBμV/m)	(dBμV)	(dB/m)	(dB)	(dB)	(cm)	(deg)	(P/A)	(H/V)	
2.4GHz 802.11g LF		31.35	16.58	-23.42	40	30.41	17.33	0.67	31.83			P	H	
		39.99	12.42	-27.58	40	30.86	12.71	0.67	31.82			P	H	
		100.74	18.59	-24.91	43.5	38.87	10.22	1.28	31.78			P	H	
		646.5	20.4	-25.6	46	30.32	19.1	3.02	32.04			P	H	
		861.4	22.36	-23.64	46	30.44	20.1	3.44	31.62			P	H	
		924.4	23.69	-22.31	46	31.18	20.2	3.55	31.24	102	36	P	H	
													H	
													H	
													H	
													H	
													H	
													H	
													H	
			30	22.19	-17.81	40	35.35	18	0.67	31.83	123	62	P	V
			58.35	19.92	-20.08	40	45.23	5.45	1.04	31.8			P	V
			100.74	14.86	-28.64	43.5	35.14	10.22	1.28	31.78			P	V
			627.6	20.01	-25.99	46	30.09	19	2.96	32.04			P	V
			930.7	22.69	-23.31	46	29.98	20.22	3.68	31.19			P	V
			948.9	22.92	-23.08	46	29.69	20.59	3.68	31.04			P	V
													V	
												V		
												V		
												V		
												V		
												V		
Remark	1. No other spurious found. 2. All results are PASS against limit line.													



15C Emission below 1GHz

2.4GHz WIFI 802.11n HT20 (LF)

WIFI	Note	Frequency	Level	Over	Limit	Read	Antenna	Cable	Preamp	Ant	Table	Peak	Pol.	
Ant.				Limit	Line	Level	Factor	Loss	Factor	Pos	Pos	Avg.		
1+2		(MHz)	(dBμV/m)	(dB)	(dBμV/m)	(dBμV)	(dB/m)	(dB)	(dB)	(cm)	(deg)	(P/A)	(H/V)	
2.4GHz 802.11n HT20 LF		30	15.35	-24.65	40	28.51	18	0.67	31.83			P	H	
		61.86	13.6	-26.4	40	39.35	5.01	1.04	31.8			P	H	
		101.01	18.31	-25.19	43.5	38.55	10.26	1.28	31.78			P	H	
		852.3	23.04	-22.96	46	31.09	20.18	3.44	31.67	109	47	P	H	
		923.7	22.73	-23.27	46	30.22	20.2	3.55	31.24			P	H	
		948.9	22.8	-23.2	46	29.57	20.59	3.68	31.04			P	H	
														H
														H
														H
														H
														H
														H
														H
														H
														H
			30.54	22.06	-17.94	40	35.49	17.73	0.67	31.83	104	53	P	V
			65.1	20.9	-19.1	40	46.75	4.9	1.04	31.79			P	V
			135.03	14.97	-28.53	43.5	34.09	11.2	1.46	31.78			P	V
			831.3	22.32	-23.68	46	30.58	20.11	3.4	31.77			P	V
			919.5	22.79	-23.21	46	30.32	20.2	3.55	31.28			P	V
		941.2	22.68	-23.32	46	29.6	20.51	3.68	31.11			P	V	
													V	
													V	
													V	
													V	
													V	
													V	
Remark	1. No other spurious found. 2. All results are PASS against limit line.													



Note symbol

*	Fundamental Frequency which can be ignored. However, the level of any unwanted emissions shall not exceed the level of the fundamental frequency per 15.209(c).
!	Test result is over limit line.
P/A	Peak or Average
H/V	Horizontal or Vertical



A calculation example for radiated spurious emission is shown as below:

WIFI	Note	Frequency	Level	Over	Limit	Read	Antenna	Cable	Preamp	Ant	Table	Peak	Pol.
Ant.				Limit	Line	Level	Factor	Loss	Factor	Pos	Pos	Avg.	
1+2		(MHz)	(dBμV/m)	(dB)	(dBμV/m)	(dBμV)	(dB/m)	(dB)	(dB)	(cm)	(deg)	(P/A)	(H/V)
802.11b		2390	55.45	-18.55	74	54.51	32.22	4.58	35.86	103	308	P	H
CH 01		2390	43.54	-10.46	54	42.6	32.22	4.58	35.86	103	308	A	H
2412MHz													

- 3. Level(dBμV/m) =
Antenna Factor(dB/m) + Cable Loss(dB) + Read Level(dBμV) - Preamp Factor(dB)
- 4. Over Limit(dB) = Level(dBμV/m) – Limit Line(dBμV/m)

For Peak Limit @ 2390MHz:

- 3. Level(dBμV/m)
= Antenna Factor(dB/m) + Cable Loss(dB) + Read Level(dBμV) - Preamp Factor(dB)
= 32.22(dB/m) + 4.58(dB) + 54.51(dBμV) – 35.86 (dB)
= 55.45 (dBμV/m)
- 4. Over Limit(dB)
= Level(dBμV/m) – Limit Line(dBμV/m)
= 55.45(dBμV/m) – 74(dBμV/m)
= -18.55(dB)

For Average Limit @ 2390MHz:

- 3. Level(dBμV/m)
= Antenna Factor(dB/m) + Cable Loss(dB) + Read Level(dBμV) - Preamp Factor(dB)
= 32.22(dB/m) + 4.58(dB) + 42.6(dBμV) – 35.86 (dB)
= 43.54 (dBμV/m)
- 4. Over Limit(dB)
= Level(dBμV/m) – Limit Line(dBμV/m)
= 43.54(dBμV/m) – 54(dBμV/m)
= -10.46(dB)

Both peak and average measured complies with the limit line, so test result is “PASS”.



Appendix C. Radiated Spurious Emission Plots

Test Engineer :	Nick Yu and James Chiu	Temperature :	22~24°C
		Relative Humidity :	55~58%

2.4GHz 2400~2483.5MHz

WIFI 802.11b (Band Edge @ 3m)

WIFI	2.4GHz 2400~2483.5MHz Band Edge @ 3m	
ANT	802.11b CH01 2412MHz	
1	Horizontal	Vertical
Peak	<p>Site : 03CH11-HY Condition : FCC CLASS-B 3m HORN 9120D-HF HORIZONTAL Detector : Peak</p>	<p>Site : 03CH11-HY Condition : FCC CLASS-B 3m HORN 9120D-HF VERTICAL Detector : Peak</p>
Avg.	<p>Site : 03CH11-HY Condition : FCC CLASS-B (AVG) 3m HORN 9120D-HF HORIZONTAL Detector : Peak</p>	<p>Site : 03CH11-HY Condition : FCC CLASS-B (AVG) 3m HORN 9120D-HF VERTICAL Detector : Peak</p>



WIFI	2.4GHz 2400~2483.5MHz Band Edge @ 3m	
ANT	802.11b CH06 2437MHz - Low channel location	
1	Horizontal	Vertical
Peak	<p>Site : 03CH11-HY Condition : FCC CLASS-B 3m HORN 9120D-HF HORIZONTAL Detector : Peak</p>	<p>Site : 03CH11-HY Condition : FCC CLASS-B 3m HORN 9120D-HF VERTICAL Detector : Peak</p>
Avg.	<p>Site : 03CH11-HY Condition : FCC CLASS-B (AVG) 3m HORN 9120D-HF HORIZONTAL Detector : Peak</p>	<p>Site : 03CH11-HY Condition : FCC CLASS-B (AVG) 3m HORN 9120D-HF VERTICAL Detector : Peak</p>

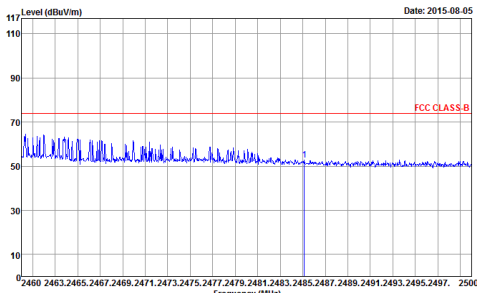
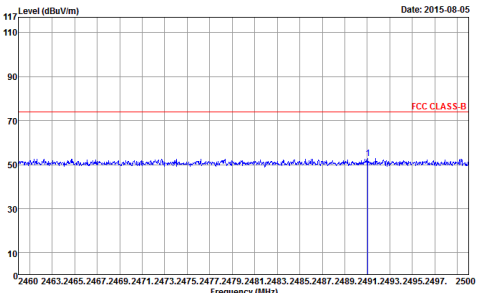
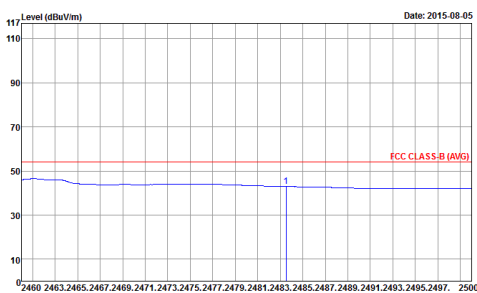
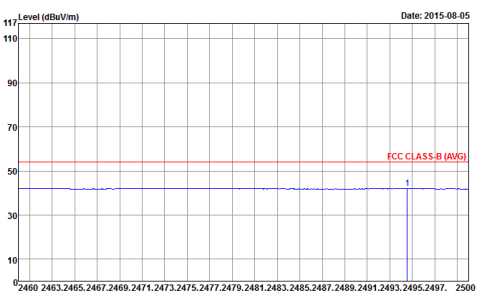

WIFI	2.4GHz 2400~2483.5MHz Band Edge @ 3m	
ANT	802.11b CH06 2437MHz - High channel location	
1	Horizontal	Vertical
Peak	 <p>Date: 2015-08-05</p> <p>Site : 03CH11-HY Condition : FCC CLASS-B 3m HORN 9120D-HF HORIZONTAL RBW:1000.000KHz VBW:3000.000KHz SWT:Auto Detector : Peak</p>	 <p>Date: 2015-08-05</p> <p>Site : 03CH11-HY Condition : FCC CLASS-B 3m HORN 9120D-HF VERTICAL RBW:1000.000KHz VBW:3000.000KHz SWT:Auto Detector : Peak</p>
Avg.	 <p>Date: 2015-08-05</p> <p>Site : 03CH11-HY Condition : FCC CLASS-B (AVG) 3m HORN 9120D-HF HORIZONTAL RBW:1000.000KHz VBW:0.010KHz SWT:Auto Detector : Peak</p>	 <p>Date: 2015-08-05</p> <p>Site : 03CH11-HY Condition : FCC CLASS-B (AVG) 3m HORN 9120D-HF VERTICAL RBW:1000.000KHz VBW:0.010KHz SWT:Auto Detector : Peak</p>



WIFI	2.4GHz 2400~2483.5MHz Band Edge @ 3m	
ANT	802.11b CH11 2462MHz	
1	Horizontal	Vertical
Peak	<p>Site : 03CH11-HY Condition : FCC CLASS-B 3m HORN 9120D-HF HORIZONTAL Detector : Peak</p>	<p>Site : 03CH11-HY Condition : FCC CLASS-B 3m HORN 9120D-HF VERTICAL Detector : Peak</p>
Avg.	<p>Site : 03CH11-HY Condition : FCC CLASS-B (AVG) 3m HORN 9120D-HF HORIZONTAL Detector : Peak</p>	<p>Site : 03CH11-HY Condition : FCC CLASS-B (AVG) 3m HORN 9120D-HF VERTICAL Detector : Peak</p>



WIFI	2.4GHz 2400~2483.5MHz Band Edge @ 3m	
ANT	802.11b CH12 2467MHz	
1	Horizontal	Vertical
Peak	<p>Date: 2015-08-06</p> <p>Site : 03CH11-HY Condition : FCC CLASS-B 3m HORN 9120D-HF HORIZONTAL RBW:1000.000KHz VBW:3000.000KHz SWT:Auto Detector : Peak</p>	<p>Date: 2015-08-06</p> <p>Site : 03CH11-HY Condition : FCC CLASS-B 3m HORN 9120D-HF VERTICAL RBW:1000.000KHz VBW:3000.000KHz SWT:Auto Detector : Peak</p>
Avg.	<p>Date: 2015-08-06</p> <p>Site : 03CH11-HY Condition : FCC CLASS-B (AVG) 3m HORN 9120D-HF HORIZONTAL RBW:1000.000KHz VBW:0.010KHz SWT:Auto Detector : Peak</p>	<p>Date: 2015-08-06</p> <p>Site : 03CH11-HY Condition : FCC CLASS-B (AVG) 3m HORN 9120D-HF VERTICAL RBW:1000.000KHz VBW:0.010KHz SWT:Auto Detector : Peak</p>



WIFI	2.4GHz 2400~2483.5MHz Band Edge @ 3m	
ANT	802.11b CH13 2472MHz	
1	Horizontal	Vertical
Peak	<p>Date: 2015-08-06</p> <p>Site : 03CH11-HY Condition : FCC CLASS-B 3m HORN 9120D-HF HORIZONTAL Detector : Peak</p>	<p>Date: 2015-08-06</p> <p>Site : 03CH11-HY Condition : FCC CLASS-B 3m HORN 9120D-HF VERTICAL Detector : Peak</p>
Avg.	<p>Date: 2015-08-06</p> <p>Site : 03CH11-HY Condition : FCC CLASS-B (AVG) 3m HORN 9120D-HF HORIZONTAL Detector : Peak</p>	<p>Date: 2015-08-06</p> <p>Site : 03CH11-HY Condition : FCC CLASS-B (AVG) 3m HORN 9120D-HF VERTICAL Detector : Peak</p>



2.4GHz 2400~2483.5MHz

WIFI 802.11b (Band Edge @ 3m)

WIFI	2.4GHz 2400~2483.5MHz Band Edge @ 3m	
ANT	802.11b CH01 2412MHz	
2	Horizontal	Vertical
Peak	<p>Site : 03CH11-HY Condition : FCC CLASS-B 3m HORN 9120D-HF HORIZONTAL RBW:1000.000KHz VBW:3000.000KHz SWT:Auto Detector : Peak</p>	<p>Site : 03CH11-HY Condition : FCC CLASS-B 3m HORN 9120D-HF VERTICAL RBW:1000.000KHz VBW:3000.000KHz SWT:Auto Detector : Peak</p>
Avg.	<p>Site : 03CH11-HY Condition : FCC CLASS-B (AVG) 3m HORN 9120D-HF HORIZONTAL RBW:1000.000KHz VBW:0.010KHz SWT:Auto Detector : Peak</p>	<p>Site : 03CH11-HY Condition : FCC CLASS-B (AVG) 3m HORN 9120D-HF VERTICAL RBW:1000.000KHz VBW:0.010KHz SWT:Auto Detector : Peak</p>



WIFI	2.4GHz 2400~2483.5MHz Band Edge @ 3m	
ANT	802.11b CH06 2437MHz - Low channel location	
2	Horizontal	Vertical
Peak	<p>Date: 2015-08-07</p> <p>Site : 03CH11-HY Condition : FCC CLASS-B 3m HORN 9120D-HF HORIZONTAL RBW:1000.000KHz VBW:3000.000KHz SWT:Auto Detector : Peak</p>	<p>Date: 2015-08-07</p> <p>Site : 03CH11-HY Condition : FCC CLASS-B 3m HORN 9120D-HF VERTICAL RBW:1000.000KHz VBW:3000.000KHz SWT:Auto Detector : Peak</p>
Avg.	<p>Date: 2015-08-07</p> <p>Site : 03CH11-HY Condition : FCC CLASS-B (AVG) 3m HORN 9120D-HF HORIZONTAL RBW:1000.000KHz VBW:0.010KHz SWT:Auto Detector : Peak</p>	<p>Date: 2015-08-07</p> <p>Site : 03CH11-HY Condition : FCC CLASS-B (AVG) 3m HORN 9120D-HF VERTICAL RBW:1000.000KHz VBW:0.010KHz SWT:Auto Detector : Peak</p>



WIFI	2.4GHz 2400~2483.5MHz Band Edge @ 3m	
ANT	802.11b CH06 2437MHz - High channel location	
2	Horizontal	Vertical
Peak	<p>Date: 2015-08-07</p> <p>Site : 03CH11-HY Condition : FCC CLASS-B 3m HORN 9120D-HF HORIZONTAL Detector : Peak</p>	<p>Date: 2015-08-07</p> <p>Site : 03CH11-HY Condition : FCC CLASS-B 3m HORN 9120D-HF VERTICAL Detector : Peak</p>
Avg.	<p>Date: 2015-08-07</p> <p>Site : 03CH11-HY Condition : FCC CLASS-B (AVG) 3m HORN 9120D-HF HORIZONTAL Detector : Peak</p>	<p>Date: 2015-08-07</p> <p>Site : 03CH11-HY Condition : FCC CLASS-B (AVG) 3m HORN 9120D-HF VERTICAL Detector : Peak</p>



WIFI	2.4GHz 2400~2483.5MHz Band Edge @ 3m	
ANT	802.11b CH11 2462MHz	
2	Horizontal	Vertical
Peak	<p>Site : 03CH11-HY Condition : FCC CLASS-B 3m HORN 9120D-HF HORIZONTAL Detector : Peak RBW:1000.000KHz VBW:3000.000KHz SWT:Auto</p>	<p>Site : 03CH11-HY Condition : FCC CLASS-B 3m HORN 9120D-HF VERTICAL Detector : Peak RBW:1000.000KHz VBW:3000.000KHz SWT:Auto</p>
Avg.	<p>Site : 03CH11-HY Condition : FCC CLASS-B (AVG) 3m HORN 9120D-HF HORIZONTAL Detector : Peak RBW:1000.000KHz VBW:0.010KHz SWT:Auto</p>	<p>Site : 03CH11-HY Condition : FCC CLASS-B (AVG) 3m HORN 9120D-HF VERTICAL Detector : Peak RBW:1000.000KHz VBW:0.010KHz SWT:Auto</p>



WIFI	2.4GHz 2400~2483.5MHz Band Edge @ 3m	
ANT	802.11b CH12 2467MHz	
2	Horizontal	Vertical
Peak	<p>Date: 2015-08-07</p> <p>Site : 03CH11-HY Condition : FCC CLASS-B 3m HORN 9120D-HF HORIZONTAL Detector : Peak</p>	<p>Date: 2015-08-07</p> <p>Site : 03CH11-HY Condition : FCC CLASS-B 3m HORN 9120D-HF VERTICAL Detector : Peak</p>
Avg.	<p>Date: 2015-08-07</p> <p>Site : 03CH11-HY Condition : FCC CLASS-B (AVG) 3m HORN 9120D-HF HORIZONTAL Detector : Peak</p>	<p>Date: 2015-08-07</p> <p>Site : 03CH11-HY Condition : FCC CLASS-B (AVG) 3m HORN 9120D-HF VERTICAL Detector : Peak</p>



WIFI	2.4GHz 2400~2483.5MHz Band Edge @ 3m	
ANT	802.11b CH13 2472MHz	
2	Horizontal	Vertical
Peak	<p>Date: 2015-08-07</p> <p>Site : 03CH11-HY Condition : FCC CLASS-B 3m HORN 9120D-HF HORIZONTAL RBW:1000.000KHz VBW:3000.000KHz SWT:Auto Detector : Peak</p>	<p>Date: 2015-08-07</p> <p>Site : 03CH11-HY Condition : FCC CLASS-B 3m HORN 9120D-HF VERTICAL RBW:1000.000KHz VBW:3000.000KHz SWT:Auto Detector : Peak</p>
Avg.	<p>Date: 2015-08-07</p> <p>Site : 03CH11-HY Condition : FCC CLASS-B (AVG) 3m HORN 9120D-HF HORIZONTAL RBW:1000.000KHz VBW:0.010KHz SWT:Auto Detector : Peak</p>	<p>Date: 2015-08-07</p> <p>Site : 03CH11-HY Condition : FCC CLASS-B (AVG) 3m HORN 9120D-HF VERTICAL RBW:1000.000KHz VBW:0.010KHz SWT:Auto Detector : Peak</p>



2.4GHz 2400~2483.5MHz

WIFI 802.11g (Band Edge @ 3m)

WIFI	2.4GHz 2400~2483.5MHz Band Edge @ 3m	
ANT	802.11g CH01 2412MHz	
1+2	Horizontal	Vertical
Peak	<p>Site : 03CH11-HY Condition : FCC CLASS-B 3m HORN 9120D-HF HORIZONTAL RBW:1000.000KHz VBW:3000.000KHz SWT:Auto Detector : Peak</p>	<p>Site : 03CH11-HY Condition : FCC CLASS-B 3m HORN 9120D-HF VERTICAL RBW:1000.000KHz VBW:3000.000KHz SWT:Auto Detector : Peak</p>
Avg.	<p>Site : 03CH11-HY Condition : FCC CLASS-B (AVG) 3m HORN 9120D-HF HORIZONTAL RBW:1000.000KHz VBW:0.010KHz SWT:Auto Detector : Peak</p>	<p>Site : 03CH11-HY Condition : FCC CLASS-B (AVG) 3m HORN 9120D-HF VERTICAL RBW:1000.000KHz VBW:0.010KHz SWT:Auto Detector : Peak</p>



WIFI	2.4GHz 2400~2483.5MHz Band Edge @ 3m	
ANT	802.11g CH06 2437MHz - Low channel location	
1+2	Horizontal	Vertical
Peak	<p>Site : 03CH11-HY Condition : FCC CLASS-B 3m HORN 9120D-HF HORIZONTAL : RBW:1000.000KHz VBW:3000.000KHz SWT:Auto Detector : Peak</p>	<p>Site : 03CH11-HY Condition : FCC CLASS-B 3m HORN 9120D-HF VERTICAL : RBW:1000.000KHz VBW:3000.000KHz SWT:Auto Detector : Peak</p>
Avg.	<p>Site : 03CH11-HY Condition : FCC CLASS-B (AVG) 3m HORN 9120D-HF HORIZONTAL : RBW:1000.000KHz VBW:0.010KHz SWT:Auto Detector : Peak</p>	<p>Site : 03CH11-HY Condition : FCC CLASS-B (AVG) 3m HORN 9120D-HF VERTICAL : RBW:1000.000KHz VBW:0.010KHz SWT:Auto Detector : Peak</p>



WIFI	2.4GHz 2400~2483.5MHz Band Edge @ 3m	
ANT	802.11g CH06 2437MHz - High channel location	
1+2	Horizontal	Vertical
Peak	<p>Date: 2015-08-07</p> <p>Site : 03CH11-HY Condition : FCC CLASS-B 3m HORN 9120D-HF HORIZONTAL : RBW:1000.000KHz VBW:3000.000KHz SWT:Auto Detector : Peak</p>	<p>Date: 2015-08-07</p> <p>Site : 03CH11-HY Condition : FCC CLASS-B 3m HORN 9120D-HF VERTICAL : RBW:1000.000KHz VBW:3000.000KHz SWT:Auto Detector : Peak</p>
Avg.	<p>Date: 2015-08-07</p> <p>Site : 03CH11-HY Condition : FCC CLASS-B (AVG) 3m HORN 9120D-HF HORIZONTAL : RBW:1000.000KHz VBW:0.010KHz SWT:Auto Detector : Peak</p>	<p>Date: 2015-08-07</p> <p>Site : 03CH11-HY Condition : FCC CLASS-B (AVG) 3m HORN 9120D-HF VERTICAL : RBW:1000.000KHz VBW:0.010KHz SWT:Auto Detector : Peak</p>

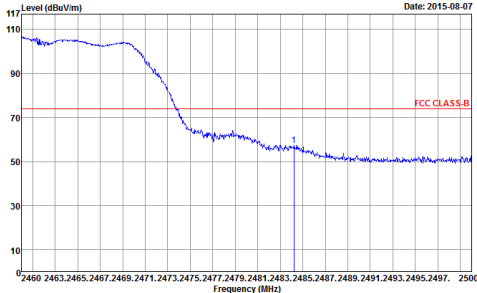
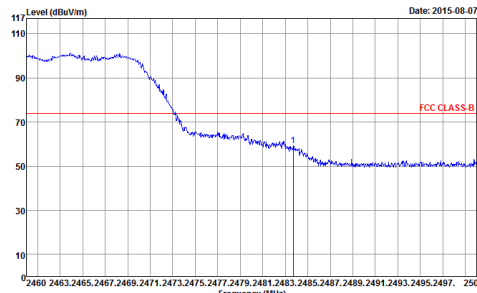
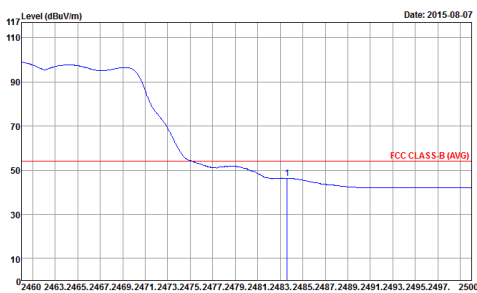
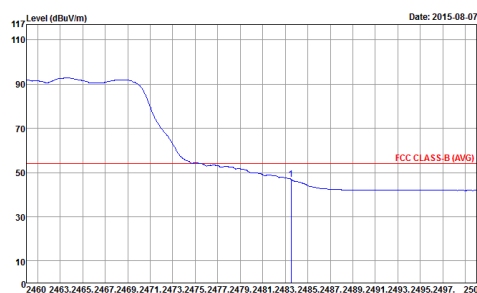

WIFI	2.4GHz 2400~2483.5MHz Band Edge @ 3m	
ANT	802.11g CH11 2462MHz	
1+2	Horizontal	Vertical
Peak	 <p>Site : 03CH11-HY Condition : FCC CLASS-B 3m HORN 9120D-HF HORIZONTAL Detector : Peak</p>	 <p>Site : 03CH11-HY Condition : FCC CLASS-B 3m HORN 9120D-HF VERTICAL Detector : Peak</p>
Avg.	 <p>Site : 03CH11-HY Condition : FCC CLASS-B (AVG) 3m HORN 9120D-HF HORIZONTAL Detector : Peak</p>	 <p>Site : 03CH11-HY Condition : FCC CLASS-B (AVG) 3m HORN 9120D-HF VERTICAL Detector : Peak</p>



WIFI	2.4GHz 2400~2483.5MHz Band Edge @ 3m	
ANT	802.11g CH12 2467MHz	
1+2	Horizontal	Vertical
Peak	<p>Date: 2015-08-07</p> <p>Site : 03CH11-HY Condition : FCC CLASS-B 3m HORN 9120D-HF HORIZONTAL RBW:1000.000KHz VBW:3000.000KHz SWT:Auto Detector : Peak</p>	<p>Date: 2015-08-07</p> <p>Site : 03CH11-HY Condition : FCC CLASS-B 3m HORN 9120D-HF VERTICAL RBW:1000.000KHz VBW:3000.000KHz SWT:Auto Detector : Peak</p>
Avg.	<p>Date: 2015-08-07</p> <p>Site : 03CH11-HY Condition : FCC CLASS-B (AVG) 3m HORN 9120D-HF HORIZONTAL RBW:1000.000KHz VBW:0.010KHz SWT:Auto Detector : Peak</p>	<p>Date: 2015-08-07</p> <p>Site : 03CH11-HY Condition : FCC CLASS-B (AVG) 3m HORN 9120D-HF VERTICAL RBW:1000.000KHz VBW:0.010KHz SWT:Auto Detector : Peak</p>

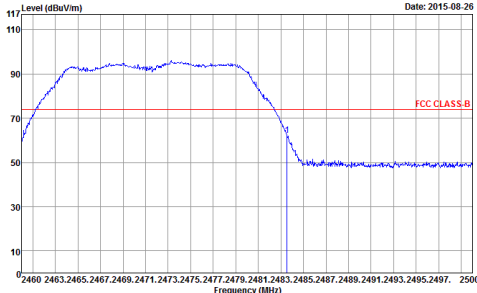
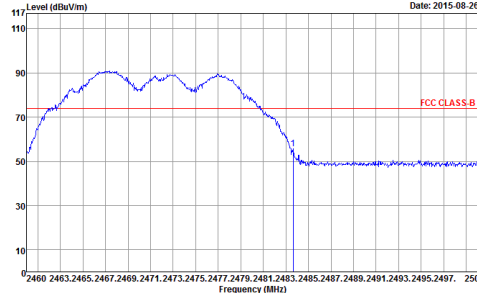
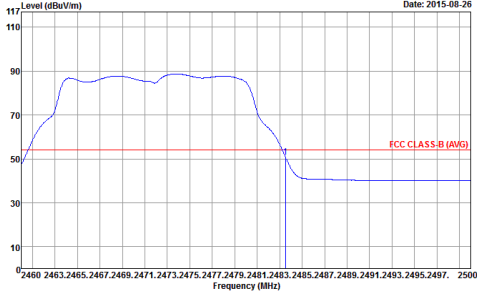
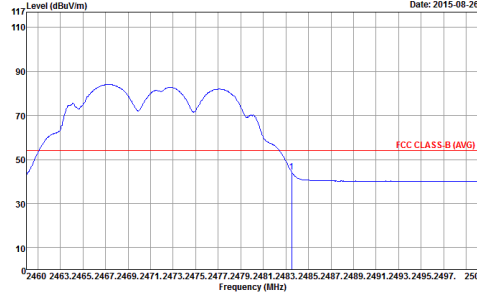

WIFI	2.4GHz 2400~2483.5MHz Band Edge @ 3m	
ANT	802.11g CH013 2472MHz	
1+2	Horizontal	Vertical
<p>Peak</p>	 <p>Date: 2015-08-26</p> <p>Site : 03CH11-HY Condition : FCC CLASS-B 3m HORN 9120D-HF HORIZONTAL Detector : Peak RBW : 1000.000KHz VBW:3000.000KHz SWT:Auto</p> <p>: RBW (6dB)</p>	 <p>Date: 2015-08-26</p> <p>Site : 03CH11-HY Condition : FCC CLASS-B 3m HORN 9120D-HF VERTICAL Detector : Peak RBW : 1000.000KHz VBW:3000.000KHz SWT:Auto</p> <p>: RBW (6dB)</p>
<p>Avg.</p>	 <p>Date: 2015-08-26</p> <p>Site : 03CH11-HY Condition : FCC CLASS-B (AVG) 3m HORN 9120D-HF HORIZONTAL Detector : Peak RBW : 1000.000KHz VBW:0.010KHz SWT:Auto</p> <p>: RBW (6dB)</p>	 <p>Date: 2015-08-26</p> <p>Site : 03CH11-HY Condition : FCC CLASS-B (AVG) 3m HORN 9120D-HF VERTICAL Detector : Peak RBW : 1000.000KHz VBW:0.010KHz SWT:Auto</p> <p>: RBW (6dB)</p>



2.4GHz 2400~2483.5MHz

WIFI 802.11n HT20 (Band Edge @ 3m)

WIFI	2.4GHz 2400~2483.5MHz Band Edge @ 3m	
ANT	802.11n HT20 CH01 2412MHz	
1+2	Horizontal	Vertical
Peak	<p>Site : 03CH11-HY Condition : FCC CLASS-B 3m HORN 9120D-HF HORIZONTAL Detector : Peak RBW:1000.000KHz VBW:3000.000KHz SWT:Auto : RBW (6dB)</p>	<p>Site : 03CH11-HY Condition : FCC CLASS-B 3m HORN 9120D-HF VERTICAL Detector : Peak RBW:1000.000KHz VBW:3000.000KHz SWT:Auto : RBW (6dB)</p>
Avg.	<p>Site : 03CH11-HY Condition : FCC CLASS-B (AVG) 3m HORN 9120D-HF HORIZONTAL Detector : Peak RBW:1000.000KHz VBW:0.010KHz SWT:Auto : RBW (6dB)</p>	<p>Site : 03CH11-HY Condition : FCC CLASS-B (AVG) 3m HORN 9120D-HF VERTICAL Detector : Peak RBW:1000.000KHz VBW:0.010KHz SWT:Auto : RBW (6dB)</p>



WIFI	2.4GHz 2400~2483.5MHz Band Edge @ 3m	
ANT	802.11n HT20 CH06 2437MHz - Low channel location	
1+2	Horizontal	Vertical
Peak	<p>Site : 03CH11-HY Condition : FCC CLASS-B 3m HORN 9120D-HF HORIZONTAL Detector : Peak</p>	<p>Site : 03CH11-HY Condition : FCC CLASS-B 3m HORN 9120D-HF VERTICAL Detector : Peak</p>
Avg.	<p>Site : 03CH11-HY Condition : FCC CLASS-B (AVG) 3m HORN 9120D-HF HORIZONTAL Detector : Peak</p>	<p>Site : 03CH11-HY Condition : FCC CLASS-B (AVG) 3m HORN 9120D-HF VERTICAL Detector : Peak</p>

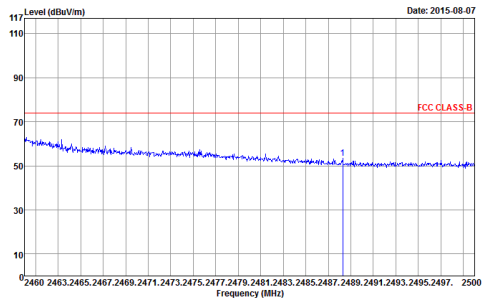
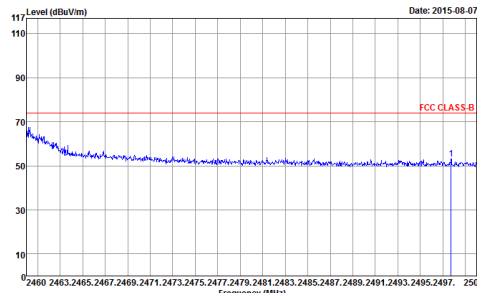
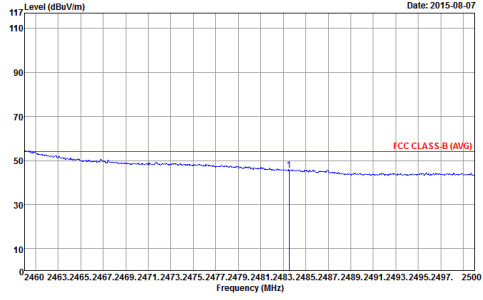
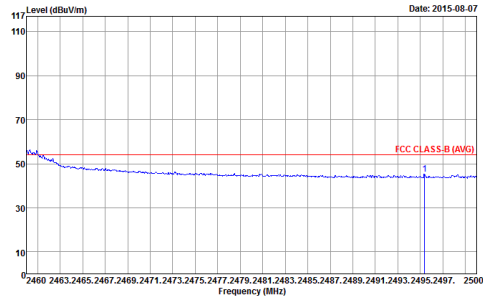

WIFI	2.4GHz 2400~2483.5MHz Band Edge @ 3m	
ANT	802.11n HT20 CH06 2437MHz -High channel location	
1+2	Horizontal	Vertical
Peak	 <p>Date: 2015-08-07</p> <p>Site : 03CH11-HY Condition : FCC CLASS-B 3m HORN 9120D-HF HORIZONTAL : RBW:1000.000KHz VBW:3000.000KHz SWT:Auto Detector : Peak</p>	 <p>Date: 2015-08-07</p> <p>Site : 03CH11-HY Condition : FCC CLASS-B 3m HORN 9120D-HF VERTICAL : RBW:1000.000KHz VBW:3000.000KHz SWT:Auto Detector : Peak</p>
Avg.	 <p>Date: 2015-08-07</p> <p>Site : 03CH11-HY Condition : FCC CLASS-B (AVG) 3m HORN 9120D-HF HORIZONTAL : RBW:1000.000KHz VBW:0.010KHz SWT:Auto Detector : Peak</p>	 <p>Date: 2015-08-07</p> <p>Site : 03CH11-HY Condition : FCC CLASS-B (AVG) 3m HORN 9120D-HF VERTICAL : RBW:1000.000KHz VBW:0.010KHz SWT:Auto Detector : Peak</p>



WIFI	2.4GHz 2400~2483.5MHz Band Edge @ 3m	
ANT	802.11n HT20 CH11 2462MHz	
1+2	Horizontal	Vertical
Peak	<p>Date: 2015-08-07</p> <p>Site : 03CH11-HY Condition : FCC CLASS-B 3m HORN 9120D-HF HORIZONTAL RBW:1000.000KHz VBW:3000.000KHz SWT:Auto Detector : Peak</p>	<p>Date: 2015-08-07</p> <p>Site : 03CH11-HY Condition : FCC CLASS-B 3m HORN 9120D-HF VERTICAL RBW:1000.000KHz VBW:3000.000KHz SWT:Auto Detector : Peak</p>
Avg.	<p>Date: 2015-08-07</p> <p>Site : 03CH11-HY Condition : FCC CLASS-B (AVG) 3m HORN 9120D-HF HORIZONTAL RBW:1000.000KHz VBW:0.010KHz SWT:Auto Detector : Peak</p>	<p>Date: 2015-08-07</p> <p>Site : 03CH11-HY Condition : FCC CLASS-B (AVG) 3m HORN 9120D-HF VERTICAL RBW:1000.000KHz VBW:0.010KHz SWT:Auto Detector : Peak</p>



WIFI	2.4GHz 2400~2483.5MHz Band Edge @ 3m	
ANT	802.11n HT20 CH12 2467MHz	
1+2	Horizontal	Vertical
Peak	<p>Date: 2015-08-07</p> <p>Site : 03CH11-HY Condition : FCC CLASS-B 3m HORN 9120D-HF HORIZONTAL RBW:1000.000KHz VBW:3000.000KHz SWT:Auto Detector : Peak</p>	<p>Date: 2015-08-07</p> <p>Site : 03CH11-HY Condition : FCC CLASS-B 3m HORN 9120D-HF VERTICAL RBW:1000.000KHz VBW:3000.000KHz SWT:Auto Detector : Peak</p>
Avg.	<p>Date: 2015-08-07</p> <p>Site : 03CH11-HY Condition : FCC CLASS-B (AVG) 3m HORN 9120D-HF HORIZONTAL RBW:1000.000KHz VBW:0.010KHz SWT:Auto Detector : Peak</p>	<p>Date: 2015-08-07</p> <p>Site : 03CH11-HY Condition : FCC CLASS-B (AVG) 3m HORN 9120D-HF VERTICAL RBW:1000.000KHz VBW:0.010KHz SWT:Auto Detector : Peak</p>



WIFI	2.4GHz 2400~2483.5MHz Band Edge @ 3m	
ANT	802.11n HT20 CH13 2472MHz	
1+2	Horizontal	Vertical
Peak	<p>Site : 03CH11-HY Condition : FCC CLASS-B 3m HORN 9120D-HF HORIZONTAL Detector : Peak : RBW (6dB)</p>	<p>Site : 03CH11-HY Condition : FCC CLASS-B 3m HORN 9120D-HF VERTICAL Detector : Peak : RBW (6dB)</p>
Avg.	<p>Site : 03CH11-HY Condition : FCC CLASS-B (AVG) 3m HORN 9120D-HF HORIZONTAL Detector : Peak : RBW (6dB)</p>	<p>Site : 03CH11-HY Condition : FCC CLASS-B (AVG) 3m HORN 9120D-HF VERTICAL Detector : Peak : RBW (6dB)</p>



2.4GHz 2400~2483.5MHz

WIFI 802.11b (Harmonic @ 3m)

WIFI	2.4GHz 2400~2483.5MHz Harmonic @ 3m	
ANT	802.11b CH01 2412MHz	
1	Horizontal	Vertical
Peak Avg.		

WIFI	2.4GHz 2400~2483.5MHz Harmonic @ 3m	
ANT	802.11b CH06 2437MHz	
1	Horizontal	Vertical
Peak Avg.		



WIFI	2.4GHz 2400~2483.5MHz Harmonic @ 3m	
ANT	802.11b CH11 2462MHz	
1	Horizontal	Vertical
Peak Avg.	<p>Site : 03CH11-HY Condition : FCC CLASS-B 3m 9170 SHF HORM_I50809 HORIZONTAL Detector : Peak</p>	<p>Site : 03CH11-HY Condition : FCC CLASS-B 3m 9170 SHF HORM_I50809 VERTICAL Detector : Peak</p>

WIFI	2.4GHz 2400~2483.5MHz Harmonic @ 3m	
ANT	802.11b CH12 2467MHz	
1	Horizontal	Vertical
Peak Avg.	<p>Site : 03CH11-HY Condition : FCC CLASS-B 3m 9170 SHF HORM_I50809 HORIZONTAL Detector : Peak</p>	<p>Site : 03CH11-HY Condition : FCC CLASS-B 3m 9170 SHF HORM_I50809 VERTICAL Detector : Peak</p>



WIFI	2.4GHz 2400~2483.5MHz Harmonic @ 3m	
ANT	802.11b CH13 2472MHz	
1	Horizontal	Vertical
Peak	<p>Site : 03CH11-HY Condition : FCC CLASS-B 3m 9170 SHF HORM_150809 HORIZONTAL Detector : Peak</p>	<p>Site : 03CH11-HY Condition : FCC CLASS-B 3m 9170 SHF HORM_150809 VERTICAL Detector : Peak</p>



WIFI	2.4GHz 2400~2483.5MHz Harmonic @ 3m	
ANT	802.11b CH01 2412MHz	
2	Horizontal	Vertical
Peak Avg.	<p>Site : 03CH11-HY Condition : FCC CLASS-B 3m 9170 SHF HORM_150809 HORIZONTAL Detector : Peak</p>	<p>Site : 03CH11-HY Condition : FCC CLASS-B 3m 9170 SHF HORM_150809 VERTICAL Detector : Peak</p>

WIFI	2.4GHz 2400~2483.5MHz Harmonic @ 3m	
ANT	802.11b CH06 2437MHz	
2	Horizontal	Vertical
Peak Avg.	<p>Site : 03CH11-HY Condition : FCC CLASS-B 3m 9170 SHF HORM_150809 HORIZONTAL Detector : Peak</p>	<p>Site : 03CH11-HY Condition : FCC CLASS-B 3m 9170 SHF HORM_150809 VERTICAL Detector : Peak</p>



WIFI	2.4GHz 2400~2483.5MHz Harmonic @ 3m	
ANT	802.11b CH11 2462MHz	
2	Horizontal	Vertical
Peak Avg.	<p>Site : 03CH11-HY Condition : FCC CLASS-B 3m 9170 SHF HORM_150809 HORIZONTAL Detector : Peak</p>	<p>Site : 03CH11-HY Condition : FCC CLASS-B 3m 9170 SHF HORM_150809 VERTICAL Detector : Peak</p>

WIFI	2.4GHz 2400~2483.5MHz Harmonic @ 3m	
ANT	802.11b CH12 2467MHz	
2	Horizontal	Vertical
Peak Avg.	<p>Site : 03CH11-HY Condition : FCC CLASS-B 3m 9170 SHF HORM_150809 HORIZONTAL Detector : Peak</p>	<p>Site : 03CH11-HY Condition : FCC CLASS-B 3m 9170 SHF HORM_150809 VERTICAL Detector : Peak</p>



WIFI	2.4GHz 2400~2483.5MHz Harmonic @ 3m	
ANT	802.11b CH13 2472MHz	
2	Horizontal	Vertical
Peak Avg.	<p>Site : 03CH11-HY Condition : FCC CLASS-B 3m 9170 SHF HORM_150809 HORIZONTAL Detector : Peak</p>	<p>Site : 03CH11-HY Condition : FCC CLASS-B 3m 9170 SHF HORM_150809 VERTICAL Detector : Peak</p>



2.4GHz 2400~2483.5MHz

WIFI 802.11g (Harmonic @ 3m)

WIFI	2.4GHz 2400~2483.5MHz Harmonic @ 3m	
ANT	802.11g CH01 2412MHz	
1+2	Horizontal	Vertical
Peak Avg.	<p>Site : 03CH11-HY Condition : FCC CLASS-B 3m 9170 SHF HORM_150809 HORIZONTAL Detector : Peak</p>	<p>Site : 03CH11-HY Condition : FCC CLASS-B 3m 9170 SHF HORM_150809 VERTICAL Detector : Peak</p>

WIFI	2.4GHz 2400~2483.5MHz Harmonic @ 3m	
ANT	802.11g CH06 2437MHz	
1+2	Horizontal	Vertical
Peak Avg.	<p>Site : 03CH11-HY Condition : FCC CLASS-B 3m 9170 SHF HORM_150809 HORIZONTAL Detector : Peak</p>	<p>Site : 03CH11-HY Condition : FCC CLASS-B 3m 9170 SHF HORM_150809 VERTICAL Detector : Peak</p>



WIFI	2.4GHz 2400~2483.5MHz Harmonic @ 3m	
ANT	802.11g CH11 2462MHz	
1+2	Horizontal	Vertical
Peak Avg.	<p>Site : 03CH11-HY Condition : FCC CLASS-B 3m 9170 SHF HORM_150809 HORIZONTAL Detector : Peak</p>	<p>Site : 03CH11-HY Condition : FCC CLASS-B 3m 9170 SHF HORM_150809 VERTICAL Detector : Peak</p>

WIFI	2.4GHz 2400~2483.5MHz Harmonic @ 3m	
ANT	802.11g CH12 2467MHz	
1+2	Horizontal	Vertical
Peak Avg.	<p>Site : 03CH11-HY Condition : FCC CLASS-B 3m 9170 SHF HORM_150809 HORIZONTAL Detector : Peak</p>	<p>Site : 03CH11-HY Condition : FCC CLASS-B 3m 9170 SHF HORM_150809 VERTICAL Detector : Peak</p>



WIFI	2.4GHz 2400~2483.5MHz Harmonic @ 3m	
ANT	802.11g CH13 2472MHz	
1+2	Horizontal	Vertical
Peak Avg.	<p>Site : 03CH11-HY Condition : FCC CLASS-B 3m 9170 SHF HORM_150809 HORIZONTAL Detector : Peak</p>	<p>Site : 03CH11-HY Condition : FCC CLASS-B 3m 9170 SHF HORM_150809 VERTICAL Detector : Peak</p>



2.4GHz 2400~2483.5MHz

WIFI 802.11n HT20 (Harmonic @ 3m)

WIFI	2.4GHz 2400~2483.5MHz Harmonic @ 3m	
ANT	802.11n HT20 CH01 2412MHz	
1+2	Horizontal	Vertical
Peak Avg.	<p>Site : 03CH11-HY Condition : FCC CLASS-B 3m 9170 SHF HORM_150809 HORIZONTAL Detector : Peak</p>	<p>Site : 03CH11-HY Condition : FCC CLASS-B 3m 9170 SHF HORM_150809 VERTICAL Detector : Peak</p>

WIFI	2.4GHz 2400~2483.5MHz Harmonic @ 3m	
ANT	802.11n HT20 CH06 2437MHz	
1+2	Horizontal	Vertical
Peak Avg.	<p>Site : 03CH11-HY Condition : FCC CLASS-B 3m 9170 SHF HORM_150809 HORIZONTAL Detector : Peak</p>	<p>Site : 03CH11-HY Condition : FCC CLASS-B 3m 9170 SHF HORM_150809 VERTICAL Detector : Peak</p>



WIFI	2.4GHz 2400~2483.5MHz Harmonic @ 3m	
ANT	802.11n HT20 CH11 2462MHz	
1+2	Horizontal	Vertical
Peak Avg.	<p>Site : 03CH11-HY Condition : FCC CLASS-B 3m 9170 SHF HORM_150809 HORIZONTAL Detector : Peak</p>	<p>Site : 03CH11-HY Condition : FCC CLASS-B 3m 9170 SHF HORM_150809 VERTICAL Detector : Peak</p>

WIFI	2.4GHz 2400~2483.5MHz Harmonic @ 3m	
ANT	802.11n HT20 CH12 2467MHz	
1+2	Horizontal	Vertical
Peak Avg.	<p>Site : 03CH11-HY Condition : FCC CLASS-B 3m 9170 SHF HORM_150809 HORIZONTAL Detector : Peak</p>	<p>Site : 03CH11-HY Condition : FCC CLASS-B 3m 9170 SHF HORM_150809 VERTICAL Detector : Peak</p>



WIFI	2.4GHz 2400~2483.5MHz Harmonic @ 3m	
ANT	802.11n HT20 CH13 2472MHz	
1+2	Horizontal	Vertical
Peak Avg.	<p>Site : 03CH11-HY Condition : FCC CLASS-B 3m 9170 SHF HORM_150809 HORIZONTAL Detector : Peak</p>	<p>Site : 03CH11-HY Condition : FCC CLASS-B 3m 9170 SHF HORM_150809 VERTICAL Detector : Peak</p>



2.4GHz 2400~2483.5MHz

Emission below 1GHz

2.4GHz WIFI 802.11b (LF)

WIFI	2.4GHz 2400~2483.5MHz	
ANT	802.11b LF	
1	Horizontal	Vertical
QP / Peak	<p>Site : 03CH11-HY Condition : FCC CLASS-B 3m CBL6112 HORIZONTAL Detector : Peak</p>	<p>Site : 03CH11-HY Condition : FCC CLASS-B 3m CBL6112 VERTICAL Detector : Peak</p>

2.4GHz 2400~2483.5MHz

Emission below 1GHz

2.4GHz WIFI 802.11b (LF)

WIFI	2.4GHz 2400~2483.5MHz	
ANT	802.11b LF	
2	Horizontal	Vertical
QP / Peak	<p>Site : 03CH11-HY Condition : FCC CLASS-B 3m CBL6112 HORIZONTAL Detector : Peak</p>	<p>Site : 03CH11-HY Condition : FCC CLASS-B 3m CBL6112 VERTICAL Detector : Peak</p>



2.4GHz 2400~2483.5MHz

Emission below 1GHz

2.4GHz WIFI 802.11g (LF)

WIFI	2.4GHz 2400~2483.5MHz	
ANT	802.11g LF	
1+2	Horizontal	Vertical
QP / Peak	<p>Site : 03CH11-HY Condition : FCC CLASS-B 3m CBL6112 HORIZONTAL Detector : Peak</p>	<p>Site : 03CH11-HY Condition : FCC CLASS-B 3m CBL6112 VERTICAL Detector : Peak</p>

2.4GHz 2400~2483.5MHz

Emission below 1GHz

2.4GHz WIFI 802.11n HT20 (LF)

WIFI	2.4GHz 2400~2483.5MHz	
ANT	802.11n HT20 LF	
1+2	Horizontal	Vertical
QP / Peak	<p>Site : 03CH11-HY Condition : FCC CLASS-B 3m CBL6112 HORIZONTAL Detector : Peak</p>	<p>Site : 03CH11-HY Condition : FCC CLASS-B 3m CBL6112 VERTICAL Detector : Peak</p>