



FCC RF Test Report

APPLICANT : Sony Mobile Communications Inc.
EQUIPMENT : Smart phone
BRAND NAME : SONY
TYPE NAME : PM-0891-BV
FCC ID : PY7-PM0891
STANDARD : FCC Part 15 Subpart E §15.407
CLASSIFICATION : (NII) Unlicensed National Information Infrastructure

The product was received on Apr. 29, 2015 and testing was completed on May 12, 2015. We, SPORTON INTERNATIONAL INC., would like to declare that the tested sample has been evaluated in accordance with the test procedures and has been in compliance with the applicable technical standards.

The test results in this report apply exclusively to the tested model / sample. Without written approval of SPORTON INTERNATIONAL INC., the test report shall not be reproduced except in full.

Reviewed by: Joseph Lin / Supervisor

Approved by: Jones Tsai / Manager



SPORTON INTERNATIONAL INC.

No. 52, Hwa Ya 1st Rd., Hwa Ya Technology Park, Kwei-Shan District, Tao Yuan City, Taiwan, R.O.C.

SPORTON INTERNATIONAL INC.

TEL : 886-3-327-3456

FAX : 886-3-328-4978

FCC ID : PY7-PM0891

Page Number : 1 of 34

Report Issued Date : Jul. 02, 2015

Report Version : Rev. 01

Report Template No.: BU5-FR15EWL Version 1.0



TABLE OF CONTENTS

SUMMARY OF TEST RESULT 4

1 GENERAL DESCRIPTION 5

 1.1 Applicant 5

 1.2 Manufacturer 5

 1.3 Feature of Equipment Under Test 5

 1.4 Product Specification of Equipment Under Test 6

 1.5 Modification of EUT 7

 1.6 Testing Location 8

 1.7 Applicable Standards 8

2 TEST CONFIGURATION OF EQUIPMENT UNDER TEST 9

 2.1 Carrier Frequency Channel 9

 2.2 Pre-Scanned RF Power 10

 2.3 Test Mode 10

 2.4 Connection Diagram of Test System 12

 2.5 Support Unit used in test configuration and system 13

 2.6 EUT Operation Test Setup 13

 2.7 Measurement Results Explanation Example 13

3 TEST RESULT 14

 3.1 26dB & 99% Occupied Bandwidth Measurement 14

 3.2 Maximum Conducted Output Power Measurement 16

 3.3 Power Spectral Density Measurement 17

 3.4 Unwanted Radiated Emission Measurement 19

 3.5 AC Conducted Emission Measurement 23

 3.6 Frequency Stability Measurement 29

 3.7 Automatically Discontinue Transmission 30

 3.8 Antenna Requirements 31

4 LIST OF MEASURING EQUIPMENTS 32

5 UNCERTAINTY OF EVALUATION 34

APPENDIX A. CONDUCTED TEST RESULTS

APPENDIX B. RADIATED TEST RESULTS



REVISION HISTORY

REPORT NO.	VERSION	DESCRIPTION	ISSUED DATE
FR542942E	Rev. 01	Initial issue of report	Jul. 02, 2015



SUMMARY OF TEST RESULT

Report Section	FCC Rule	Description	Limit	Result	Remark
3.1	2.1049 15.403(i)	26dB & 99% Bandwidth	-	Pass	-
3.2	15.407(a)	Maximum Conducted Output Power	FCC ≤ 24 dBm (depend on band)	Pass	-
3.3	15.407(a)	Power Spectral Density	FCC ≤ 11 dBm (depend on band)	Pass	-
3.4	15.407(b)	Unwanted Emissions	≤ -17, -27 dBm (depend on band)&15.209(a)	Pass	Under limit 3.16 dB at 5470.000 MHz
3.5	15.207	AC Conducted Emission	15.207(a)	Pass	Under limit 10.90 dB at 2.878 MHz
3.6	15.407(g)	Frequency Stability	Within Operation Band	Pass	-
3.7	15.407(c)	Automatically Discontinue Transmission	Discontinue Transmission	Pass	-
3.8	15.203 & 15.407(a)	Antenna Requirement	N/A	Pass	-



1 General Description

1.1 Applicant

Sony Mobile Communications Inc.
Nya Vattentorget, 22188 Lund, Sweden

1.2 Manufacturer

Arima Communications Corp.
6F, No. 866, Jhongjheng Rd., Jhonghe Dist., New Taipei City 23586, Taiwan

1.3 Feature of Equipment Under Test

The Equipment Under Test (hereafter called: EUT) is Smart phone supporting, GSM/WCDMA/LTE, Wi-Fi 2.4GHz 802.11b/g/n, Wi-Fi 5GHz 802.11a/n, Bluetooth with FM Receiver, GPS, and NFC features, and below is details of information.

Product Feature	
Equipment	Smart phone
Brand Name	SONY
Type Name	PM-0891-BV
FCC ID	PY7-PM0891
GSM Operating Band(s)	GSM 850/900/1800/1900MHz
GPRS / EGPRS Multi Slot Class	GPRS Class 12, EGPRS Class 12
WCDMA Operating Band(s)	FDD Band I / II / V / VIII
WCDMA Rel. Version	Rel. 8
LTE Operating Band(s)	FDD Band I / III / V / VII / VIII / XXVIII TDD Band XL
LTE Rel. Version	Rel. 8
Wi-Fi Specification	802.11a/b/g/n (HT20/HT40)
Bluetooth Version	v3.0+EDR / v4.0-LE
NFC Specification	ISO14443A / ISO14443B / Felica
Power Supply	Battery / AC Adapter / Car Charger

Remark: The above EUT's information was declared by manufacturer. Please refer to the specifications or user's manual for more detailed description.



1.4 Product Specification of Equipment Under Test

Product Specification subjective to this standard	
Tx/Rx Frequency Range	5180 MHz ~ 5240 MHz 5260 MHz ~ 5320 MHz 5500 MHz ~ 5580 MHz 5660 MHz ~ 5700 MHz
Maximum Output Power to Antenna	<5180 MHz ~ 5240 MHz> 802.11a : 11.48 dBm / 0.0141 W 802.11n HT20 : 11.42 dBm / 0.0139 W 802.11n HT40 : 11.05 dBm / 0.0127 W <5260 MHz ~ 5320 MHz> 802.11a : 11.47 dBm / 0.0140 W 802.11n HT20 : 11.49 dBm / 0.0141 W 802.11n HT40 : 11.46 dBm / 0.0140 W <5500 MHz ~ 5580 MHz and 5660 MHz ~ 5700 MHz> 802.11a : 11.49 dBm / 0.0141 W 802.11n HT20 : 11.48 dBm / 0.0141 W 802.11n HT40 : 11.35 dBm / 0.0136 W
99% Occupied Bandwidth	802.11a : 17.75 MHz 802.11n HT20 : 18.55 MHz 802.11n HT40 : 36.60 MHz
Antenna Type & Gain	<5180 MHz ~ 5240 MHz> PIFA Antenna with gain -1.60 dBi <5260 MHz ~ 5320 MHz> PIFA Antenna with gain -1.50 dBi <5500 MHz ~ 5580 MHz and 5660 MHz ~ 5700 MHz> PIFA Antenna with gain -1.50 dBi
Type of Modulation	OFDM (BPSK / QPSK / 16QAM / 64QAM)

EUT Information List				
IMEI	HW Version	SW Version	S/N	Performed Test Item
IMEI 1: 004402454617220 IMEI 2: 004402454617238	A	29.0.B.0.76	WUJ01HWJMD	RF conducted measurement
IMEI 1: 004402454617303 IMEI 2: 004402454617311			WUJ01HWJRA	Radiated Spurious Emission
IMEI 1: 004402454617709 IMEI 2: 004402454617717			WUJ01HWK59	Conducted Emission



Accessory List	
AC Adapter	Model No. : EP800
	Type No. : CAA-0002016-US B
	S/N :
	3113W 45 108545 (for Radiation Spurious Emission) 3113W 38 210631 (for Conducted Emission)
Battery	Model No. : LIS1579ERPC
Earphone 1	Model No. : MH410c
	Type No. : AG-1100
	S/N : 13511E63001BFF6 (for Radiation Spurious Emission)
Earphone 2	Model No. : MH410c
	Type No. : AG-1103
	S/N :
	1428204D011619A (for Radiation Spurious Emission) 14292040011682C (for Conducted Emission)
USB Cable	Model No. : EC450
	Type No. : AI-0700
	S/N :
	143412DE1065866 (for Radiation Spurious Emission) 134912D1000585A (for Conducted Emission)

Note:

1. Above EUT list and accessory list used are electrically identical per declared by manufacturer.
2. Above the accessories list are used to exercise the EUT during test.
3. For other wireless features of this EUT, test report will be issued separately.

1.5 Modification of EUT

No modifications are made to the EUT during all test items.



1.6 Testing Location

Sporton Lab is accredited to ISO 17025 by Taiwan Accreditation Foundation (TAF code : 1190) and the FCC designation No. TW1022 under the FCC 2.948(e) by Mutual Recognition Agreement (MRA) in FCC Test.

Test Site	SPORTON INTERNATIONAL INC.	
Test Site Location	No. 52, Hwa Ya 1 st Rd., Hwa Ya Technology Park, Kwei-Shan District, Tao Yuan City, Taiwan, R.O.C. TEL: +886-3-327-3456 FAX: +886-3-328-4978	
Test Site No.	Sporton Site No.	
	TH05-HY	CO05-HY

Test Site	SPORTON INTERNATIONAL INC.	
Test Site Location	No.58, Aly. 75, Ln. 564, Wenhua 3rd Rd. Guishan District, Taoyuan City, Taiwan (R.O.C.) TEL: +886-3-327-0855	
Test Site No.	Sporton Site No.	
	03CH11-HY	

Note: The test site complies with ANSI C63.4 2009 requirement.

1.7 Applicable Standards

According to the specifications of the manufacturer, the EUT must comply with the requirements of the following standards:

- ♦ FCC Part 15 Subpart E
- ♦ FCC KDB 789033 D02 General UNII Test Procedures New Rules v01
- ♦ ANSI C63.10-2009

Remark:

1. All test items were verified and recorded according to the standards and without any deviation during the test.
2. FCC permits the use of the 1.5 meter table as an alternative in C63.10-2013 through inquiry tracking number 961829.
3. This EUT has also been tested and complied with the requirements of FCC Part 15, Subpart B, recorded in a separate test report.



2 Test Configuration of Equipment Under Test

The EUT has been associated with peripherals and configuration operated in a manner tended to maximize its emission characteristics in a typical application. Frequency range investigated: conducted emission (150 kHz to 30 MHz) and radiated emission (9 kHz to the 10th harmonic of the highest fundamental frequency or to 40 GHz, whichever is lower). For radiated measurement, pre-scanned in three orthogonal panels, X, Y, Z. The worst cases (X plane) were recorded in this report.

The final configuration from all the combinations and the worst-case data rates were investigated by measuring the maximum power across all the data rates and modulation modes under section 2.2.

Based on the worst configuration found above, the RF power setting is set individually to meet FCC compliance limit for the final conducted and radiated tests shown in section 2.3.

2.1 Carrier Frequency Channel

Frequency Band	Channel	Freq. (MHz)	Channel	Freq. (MHz)
5150-5250 MHz Band 1 (U-NII-1)	36	5180	44	5220
	38	5190	46	5230
	40	5200	48	5240

Frequency Band	Channel	Freq. (MHz)	Channel	Freq. (MHz)
5250-5350 MHz Band 2 (U-NII-2A)	52	5260	60	5300
	54	5270	62	5310
	56	5280	64	5320

Frequency Band	Channel	Freq. (MHz)	Channel	Freq. (MHz)
5470-5600 MHz and 5650-5725 MHz Band 3 (U-NII-2C)	100	5500	116	5580
	102	5510	132	5660
	104	5520	134	5670
	108	5540	136	5680
	110	5550	140	5700
	112	5560		

Note: The above Frequency and Channel in boldface were 802.11n HT40.



2.2 Pre-Scanned RF Power

Preliminary tests were performed in different data rate and data rate associated with the highest power were chosen for full test in the following tables.

5GHz 802.11a mode								
Data Rate (MHz)	6M bps	9M bps	12M bps	18M bps	24M bps	36M bps	48M bps	54M bps
Average Power (dBm)	11.49	11.07	11.46	11.43	11.39	11.24	11.44	11.47

5GHz 802.11n HT20 mode								
Data Rate (MHz)	MCS0	MCS1	MCS2	MCS3	MCS4	MCS5	MCS6	MCS7
Average Power (dBm)	11.49	11.48	11.47	11.45	11.47	11.45	11.42	11.43

5GHz 802.11n HT40 mode								
Data Rate (MHz)	MCS0	MCS1	MCS2	MCS3	MCS4	MCS5	MCS6	MCS7
Average Power (dBm)	11.46	11.44	11.44	11.43	11.41	11.39	11.42	11.45

2.3 Test Mode

Final test mode of conducted test items and radiated spurious emissions are considering the modulation and worse data rates from the power table described in section 2.2.

Modulation	Data Rate
802.11a	6 Mbps
802.11n HT20	MCS0
802.11n HT40	MCS0

AC Conducted Emission	Mode 1 : GSM1900 Idle + Bluetooth Link + WLAN (5GHz) Link + Earphone 2 + Battery + MP3 + USB Cable (Charging from Adapter) + SIM2
-----------------------	---

Remark: For Radiated TCs, the tests were performed with SIM 1.



Ch. #		Band I : 5150-5250 MHz	Band II : 5250-5350 MHz	Band III : 5470-5600 MHz and 5650-5725MHz
		802.11a	802.11a	802.11a
L	Low	36	52	100
M	Middle	44	60	116
H	High	48	64	140

Ch. #		Band I : 5150-5250 MHz	Band II : 5250-5350 MHz	Band III : 5470-5600 MHz and 5650-5725MHz
		802.11n HT20	802.11n HT20	802.11n HT20
L	Low	36	52	100
M	Middle	44	60	116
H	High	48	64	140

Ch. #		Band I : 5150-5250 MHz	Band II : 5250-5350 MHz	Band III : 5470-5600 MHz and 5650-5725MHz
		802.11n HT40	802.11n HT40	802.11n HT40
L	Low	38	54	102
M	Middle	-	-	110
H	High	46	62	134

2.4 Connection Diagram of Test System

<WLAN Tx Mode>

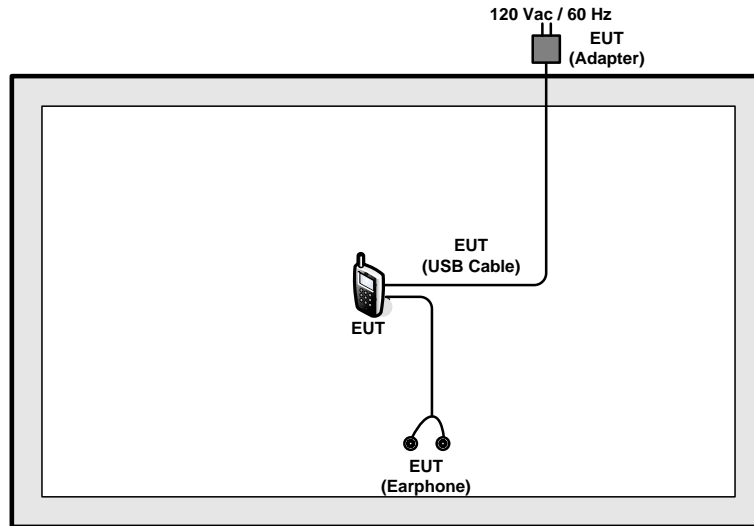

<AC Conducted Emission Mode>

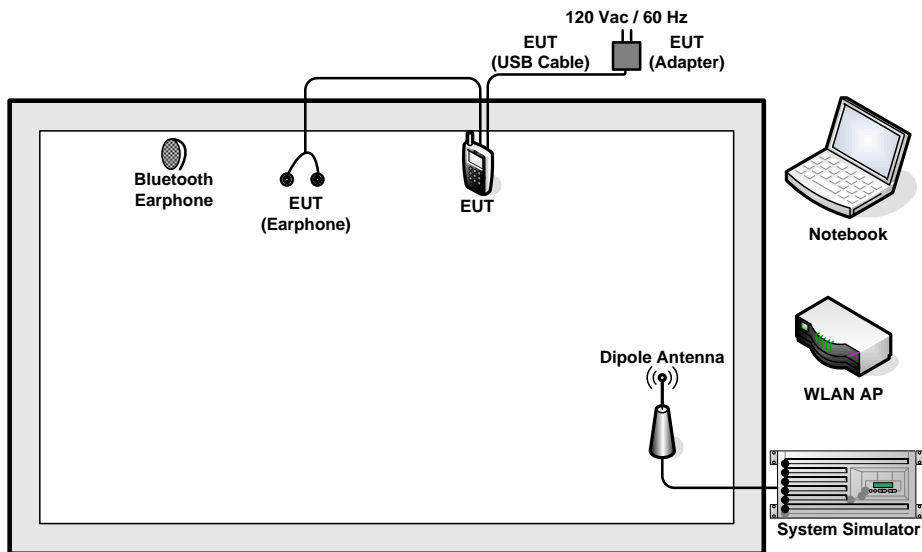



2.5 Support Unit used in test configuration and system

Item	Equipment	Trade Name	Model Name	FCC ID	Data Cable	Power Cord
1.	System Simulator	Anritsu	MT8820C	N/A	N/A	Unshielded, 1.8 m
2.	Notebook	DELL	Latitude E6320	FCC DoC/ Contains FCC ID: QDS-BRCM1054	N/A	AC I/P: Unshielded, 1.2 m DC O/P: Shielded, 1.8 m
3.	WLAN AP	D-Link	DIR-865L	KA2IR865LA1	N/A	Unshielded, 1.8 m
4.	Bluetooth Earphone	Sony	SBH20	PY7-RD0010	Unshielded, 0.75m	N/A
5.	SD Card	SanDisk	MicroSD HC	FCC DoC	N/A	N/A

2.6 EUT Operation Test Setup

For WLAN function, programmed RF utility, EUT provide functions like channel selection and power level for continuous transmitting and receiving signals.

2.7 Measurement Results Explanation Example

For all conducted test items:

The offset level is set in the spectrum analyzer to compensate the RF cable loss and attenuator factor between EUT conducted output port and spectrum analyzer. With the offset compensation, the spectrum analyzer reading level is exactly the EUT RF output level.

Example :

The spectrum analyzer offset is derived from RF cable loss and attenuator factor.

Offset = RF cable loss + attenuator factor.

Following shows an offset computation example with cable loss 4.2 dB and 10dB attenuator.

$$\begin{aligned}
 \text{Offset(dB)} &= \text{RF cable loss(dB)} + \text{attenuator factor(dB)}. \\
 &= 4.2 + 10 = 14.2 \text{ (dB)}
 \end{aligned}$$

3 Test Result

3.1 26dB & 99% Occupied Bandwidth Measurement

3.1.1 Description of 26dB & 99% Occupied Bandwidth

This section is for reporting purpose only.

There is no restriction limits for bandwidth.

3.1.2 Measuring Instruments

The measuring equipment is listed in the section 4 of this test report.

3.1.3 Test Procedures

1. The testing follows FCC KDB 789033 D02 General UNII Test Procedures New Rules v01.
Section C) Emission bandwidth
2. Set RBW = approximately 1% of the emission bandwidth.
3. Set the VBW > RBW.
4. Detector = Peak.
5. Trace mode = max hold
6. Measure the maximum width of the emission that is 26 dB down from the peak of the emission.
Compare this with the RBW setting of the analyzer. Readjust RBW and repeat measurement as needed until the RBW/EBW ratio is approximately 1%.
7. For 99% Bandwidth Measurement, the spectrum analyzer's resolution bandwidth (RBW) is set 1MHz and set the Video bandwidth (VBW) $\geq 3 * RBW$.
8. Measure and record the results in the test report.

3.1.4 Test Setup

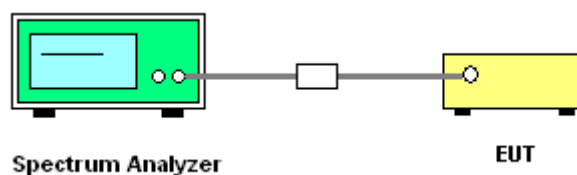



3.1.5 Test Result of 26dB & 99% Occupied Bandwidth Plots

Please refer to Appendix A.

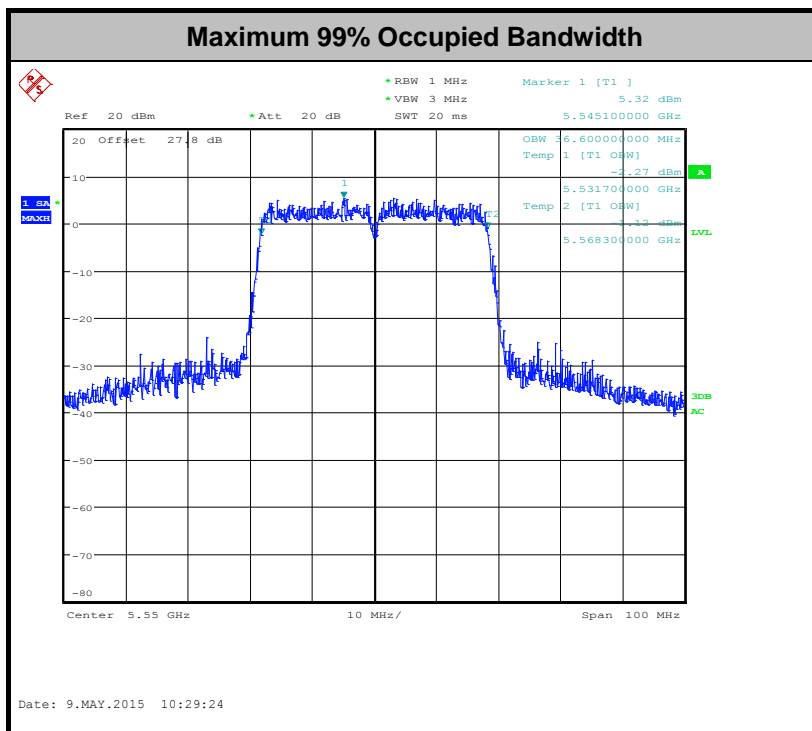
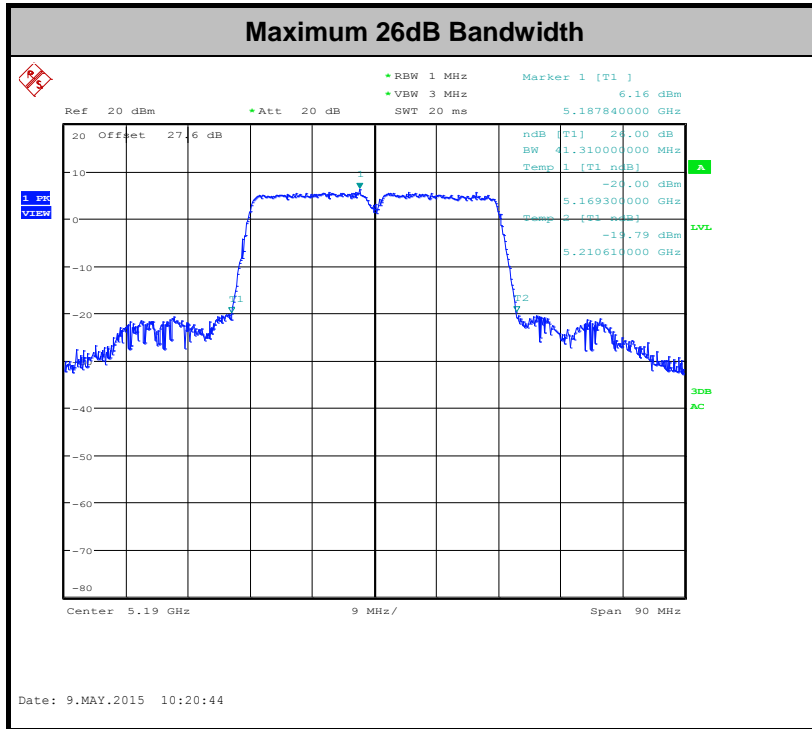

3.2 Maximum Conducted Output Power Measurement

3.2.1 Limit of Maximum Conducted Output Power

<FCC 14-30 CFR 15.407>

For mobile and portable client devices in the 5.15–5.25 GHz band, the maximum conducted output power over the frequency band of operation shall not exceed 250 mW.

For the 5.25–5.35 GHz and 5.47–5.725 GHz bands, the maximum conducted output power over the frequency bands of operation shall not exceed the lesser of 250 mW or $11 \text{ dBm} + 10 \log B$, where B is the 26 dB emission bandwidth in megahertz.

If transmitting antennas of directional gain greater than 6 dBi are used, the peak output power shall be reduced by the amount in dB that the directional gain of the antenna exceeds 6 dBi.

Note that U-NII-2 band, devices with a maximum e.i.r.p. greater than 500 mW shall implement TPC in order to have the capability to operate at least 6 dB below the maximum permitted e.i.r.p. of 1 W.

3.2.2 Measuring Instruments

The measuring equipment is listed in the section 4 of this test report.

3.2.3 Test Procedures

The testing follows Method PM of FCC KDB 789033 D02 General UNII Test Procedures New Rules v01.

Method PM (Measurement using an RF average power meter):

1. Measurement is performed using a wideband RF power meter.
2. The EUT is configured to transmit continuously with a consistent duty cycle at its maximum power control level.
3. Measure the average power of the transmitter, and the average power is corrected with duty factor, $10 \log(1/x)$, where x is the duty cycle.

3.2.4 Test Setup

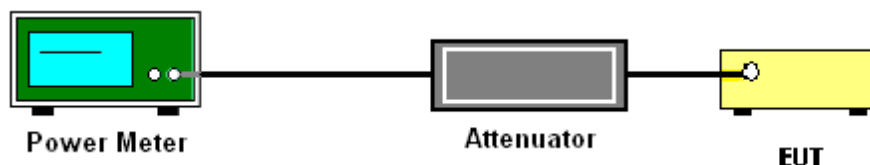

3.2.5 Test Result of Maximum Conducted Output Power

Please refer to Appendix A.



3.3 Power Spectral Density Measurement

3.3.1 Limit of Power Spectral Density

<FCC 14-30 CFR 15.407>

For mobile and portable client devices in the 5.15–5.25 GHz band, the maximum power spectral density shall not exceed 11dBm in any 1 megahertz band.

For the 5.25–5.35 GHz and 5.47–5.725 GHz bands, the maximum power spectral density shall not exceed 11 dBm in any 1 megahertz band.

If transmitting antennas of directional gain greater than 6 dBi are used, the peak output power shall be reduced by the amount in dB that the directional gain of the antenna exceeds 6 dBi.

3.3.2 Measuring Instruments

The measuring equipment is listed in the section 4 of this test report.

3.3.3 Test Procedures

The testing follows FCC KDB 789033 D02 General UNII Test Procedures New Rules v01.

Section F) Maximum power spectral density.

Method SA-2

(trace averaging across on and off times of the EUT transmissions, followed by duty cycle correction).

1. The testing follows Method SA-2 of FCC KDB 789033 D02 General UNII Test Procedures New Rules v01.
 - Measure the duty cycle.
 - Set span to encompass the entire emission bandwidth (EBW) of the signal.
 - Set RBW = 1 MHz.
 - Set VBW \geq 3 MHz.
 - Number of points in sweep \geq 2 Span / RBW.
 - Sweep time = auto.
 - Detector = RMS
 - Trace average at least 100 traces in power averaging mode.
 - Add $10 \log(1/x)$, where x is the duty cycle, to the measured power in order to compute the average power during the actual transmission times. For example, add $10 \log(1/0.25) = 6$ dB if the duty cycle is 25 percent.
2. The RF output of EUT was connected to the spectrum analyzer by a low loss cable.
3. Each plot has already offset with cable loss, and attenuator loss. Measure the PPSD and record it.

3.3.4 Test Setup

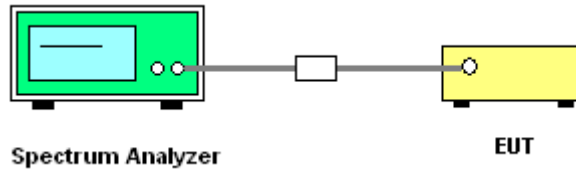

3.3.5 Test Result of Power Spectral Density

Please refer to Appendix A.

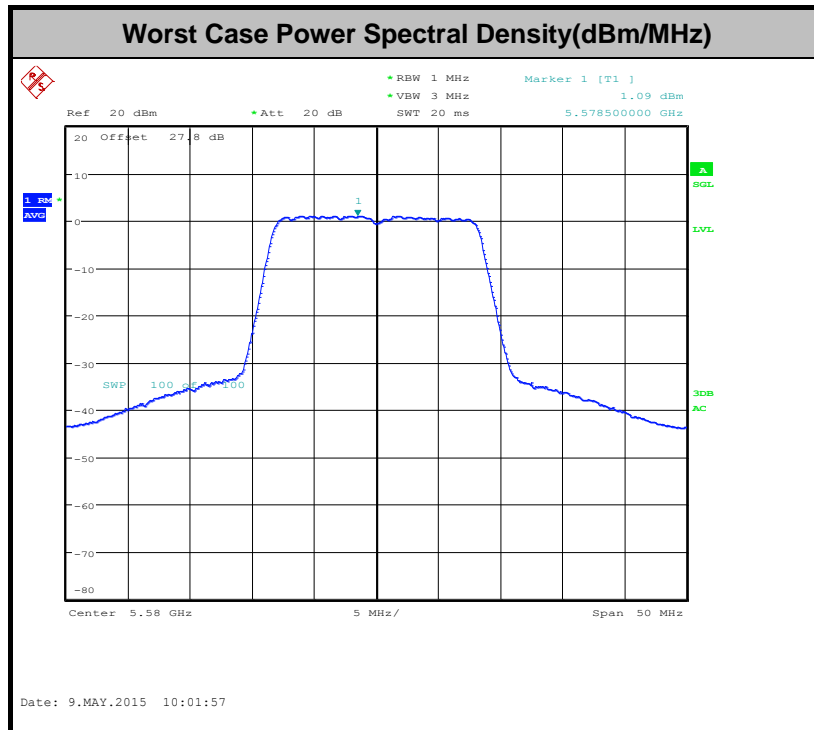

Note: Average Power Density (dB) = Measured value+ Duty Factor



3.4 Unwanted Radiated Emission Measurement

This section as specified in FCC Part 15.407(b) is to measure unwanted emissions through radiated measurement for band edge spurious emissions and out of band emissions measurement. The unwanted emissions shall comply with 15.407(b)(1) to (6), and restricted bands per FCC Part15.205.

3.4.1 Limit of Unwanted Emissions

(1) For transmitters operating in the 5150-5250 MHz band: all emissions outside of the 5150-5350 MHz band shall not exceed an EIRP of -27dBm/MHz.

For transmitters operating in the 5250-5350 MHz band: all emissions outside of the 5150-5350 MHz band shall not exceed an EIRP of -27 dBm/MHz. Devices operating in the 5250-5350 MHz band that generate emissions in the 5150-5250 MHz band must meet all applicable technical requirements for operation in the 5150-5250 MHz band (including indoor use) or alternatively meet an out-of-band emission EIRP limit of -27 dBm/MHz in the 5150-5250 MHz band.

For transmitters operating in the 5470-5600 MHz and 5650-5725MHz band: all emissions outside of the 5470-5600 MHz and 5650-5725MHz band shall not exceed an EIRP of -27 dBm/MHz.

(2) Unwanted spurious emissions fallen in restricted bands per FCC Part15.205 shall comply with the general field strength limits set forth in § 15.209 as below table,

Frequency (MHz)	Field Strength (microvolts/meter)	Measurement Distance (meters)
0.009 – 0.490	2400/F(kHz)	300
0.490 – 1.705	24000/F(kHz)	30
1.705 – 30.0	30	30
30 – 88	100	3
88 – 216	150	3
216 - 960	200	3
Above 960	500	3

Note: The following formula is used to convert the EIRP to field strength.

$$E = \frac{1000000\sqrt{30P}}{3} \mu\text{V/m, where P is the eirp (Watts)}$$

EIRP (dBm)	Field Strength at 3m (dBμV/m)
-17	78.3
- 27	68.3



(3) KDB789033 v01 G)2)c) As specified in 15.407(b), emissions above 1000 MHz that are outside of the restricted bands are subject to a peak emission limit of -27 dBm/MHz (or -17 dBm/MHz as specified in 15.407(b)(4)). However, an out-of-band emission that complies with both the average and peak limits of 15.209 is not required to satisfy the -27 dBm/MHz or -17 dBm/MHz peak emission limit.

3.4.2 Measuring Instruments

The measuring equipment is listed in the section 4 of this test report.

3.4.3 Test Procedures

1. The testing follows FCC KDB 789033 D02 General UNII Test Procedures New Rules v01. Section G) Unwanted emissions measurement.

(1) Procedure for Unwanted Emissions Measurements Below 1000MHz

- RBW = 120 kHz
• VBW = 300 kHz
• Detector = Peak
• Trace mode = max hold

(2) Procedure for Peak Unwanted Emissions Measurements Above 1000 MHz

- RBW = 1 MHz
• VBW ≥ 3 MHz
• Detector = Peak
• Sweep time = auto
• Trace mode = max hold

(3) Procedures for Average Unwanted Emissions Measurements Above 1000MHz

- RBW = 1 MHz
• VBW = 10 Hz, when duty cycle is no less than 98 percent.
• VBW ≥ 1/T, when duty cycle is less than 98 percent where T is the minimum transmission duration over which the transmitter is on and is transmitting at its maximum power control level for the tested mode of operation.

Table with 5 columns: Band, Duty Cycle(%), T(μs), 1/T(kHz), VBW Setting. Rows include 802.11a, 802.11n HT20, and 802.11n HT40.

2. The EUT was placed on a turntable with 0.8 meter for frequency below 1GHz and 1.5 meter for frequency above 1GHz respectively above ground.
3. The EUT was set 3 meters from the interference receiving antenna which was mounted on the top of a variable height antenna tower.
4. The antenna is a broadband antenna and its height is adjusted between one meter and four meters above ground to find the maximum value of the field strength for both horizontal polarization and vertical polarization of the antenna.
5. For each suspected emission, the EUT was arranged to its worst case and then adjust the antenna tower (from 1 m to 4 m) and turntable (from 0 degree to 360 degrees) to find the maximum reading.
6. For testing below 1GHz, if the emission level of the EUT in peak mode was 3 dB lower than the limit specified, then peak values of EUT will be reported, otherwise, the emissions will be repeated one by one using the CISPR quasi-peak method and reported.
7. For testing above 1GHz, the emission level of the EUT in peak mode was 20dB lower than average limit (that means the emission level in average mode also complies with the limit in average mode), then peak values of EUT will be reported, otherwise, the emissions will be measured in average mode again and reported.

3.4.4 Test Setup

For radiated emissions below 30MHz

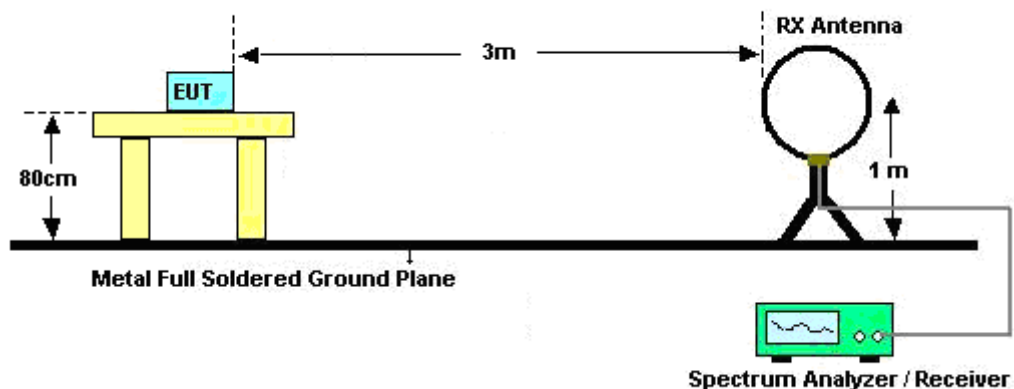

For radiated emissions from 30MHz to 1GHz

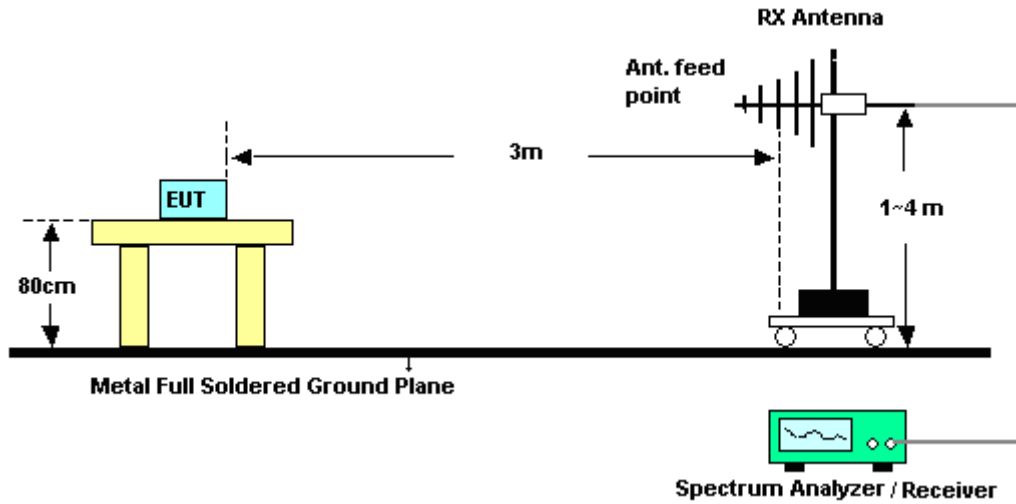

For radiated emissions above 1GHz

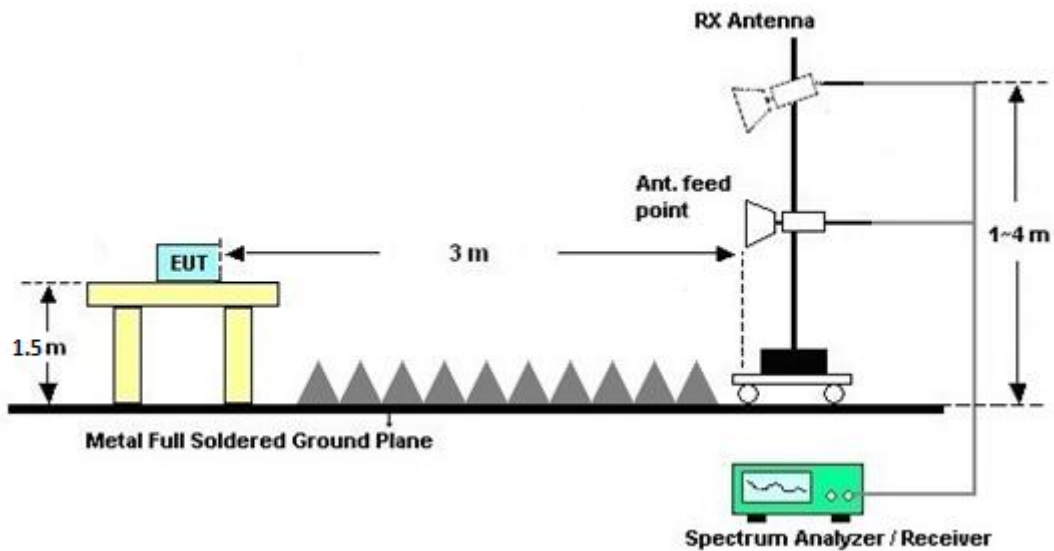

3.4.5 Test Results of Radiated Emissions (9 kHz ~ 30 MHz)

The low frequency, which started from 9 kHz to 30MHz, was pre-scanned and the result which was 20dB lower than the limit line per 15.31(o) was not reported.

3.4.6 Test Result of Radiated Band Edges

Please refer to Appendix A.

3.4.7 Test Result of Unwanted Radiated Emission (30MHz ~ 10th Harmonic)

Please refer to Appendix A.



3.5 AC Conducted Emission Measurement

3.5.1 Limit of AC Conducted Emission

For equipment that is designed to be connected to the public utility (AC) power line, the radio frequency voltage that is conducted back onto the AC power line on any frequency or frequencies within the band 150 kHz to 30 MHz shall not exceed the limits in the following table.

Frequency of emission (MHz)	Conducted limit (dB μ V)	
	Quasi-peak	Average
0.15-0.5	66 to 56*	56 to 46*
0.5-5	56	46
5-30	60	50

*Decreases with the logarithm of the frequency.

3.5.2 Measuring Instruments

The measuring equipment is listed in the section 4 of this test report.

3.5.3 Test Procedures

1. The EUT was placed 0.4 meter from the conducting wall of the shielding room was kept at least 80 centimeters from any other grounded conducting surface.
2. Connect EUT to the power mains through a line impedance stabilization network (LISN).
3. All the support units are connecting to the other LISN.
4. The LISN provides 50 ohm coupling impedance for the measuring instrument.
5. The FCC states that a 50 ohm, 50 microhenry LISN should be used.
6. Both sides of AC line were checked for maximum conducted interference.
7. The frequency range from 150 kHz to 30 MHz was searched.
8. Set the test-receiver system to Peak Detect Function and specified bandwidth with Maximum Hold Mode.

3.5.4 Test Setup

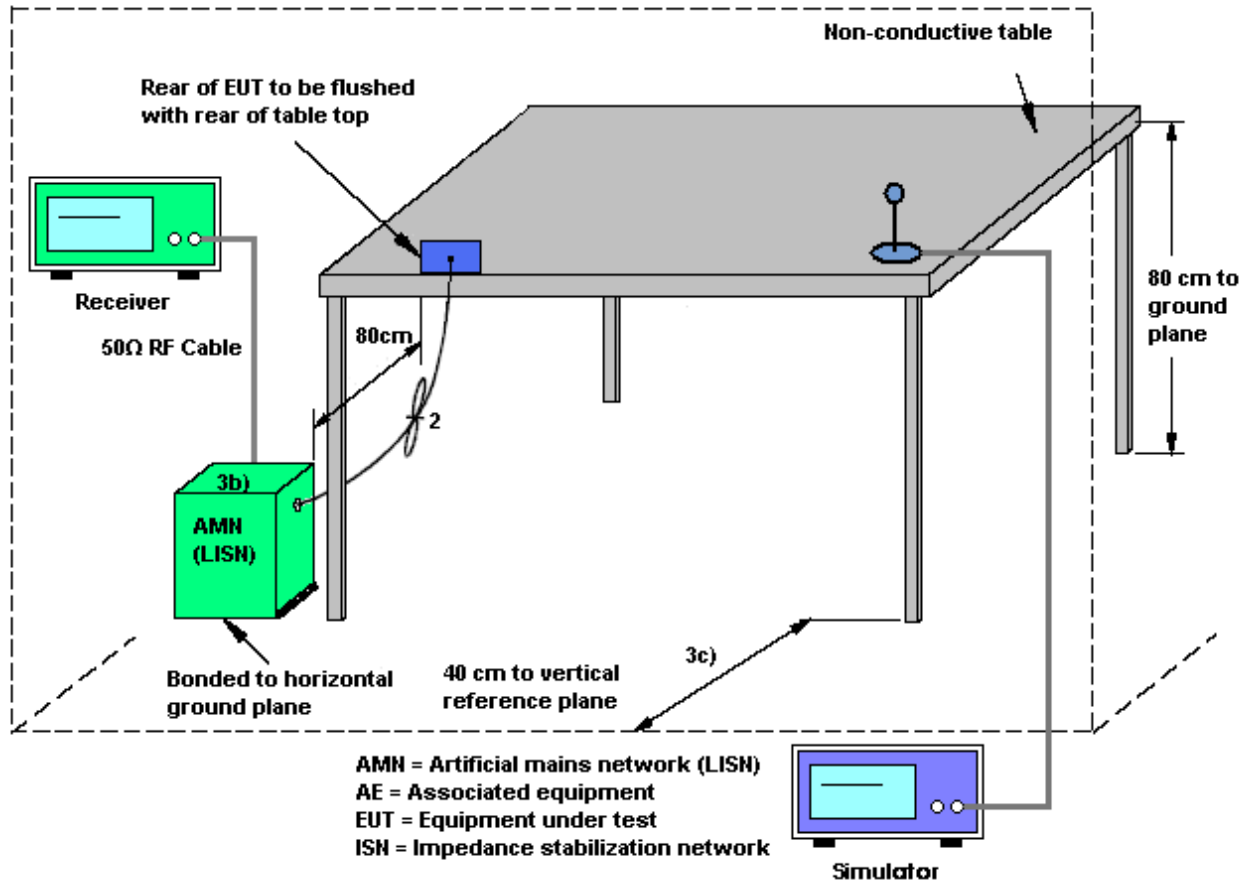



3.5.5 Test Result of AC Conducted Emission

Test Mode :	Mode 1	Temperature :	24~25°C
Test Engineer :	Kai-Chun Chu	Relative Humidity :	53~54%
Test Voltage :	120Vac / 60Hz	Phase :	Line
Function Type :	GSM1900 Idle + Bluetooth Link + WLAN (5GHz) Link + Earphone 2 + Battery + MP3 + USB Cable (Charging from Adapter) + SIM2		

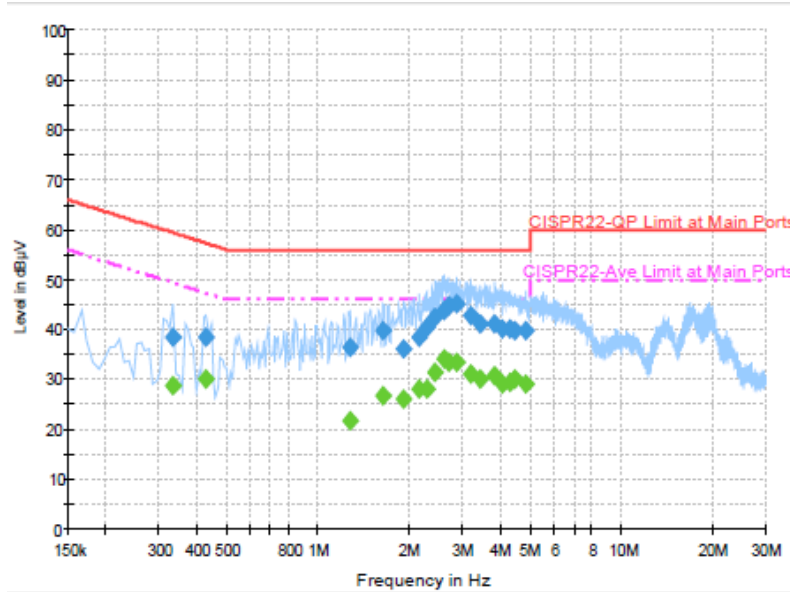

Final Result : QuasiPeak

Frequency (MHz)	QuasiPeak (dBµV)	Filter	Line	Corr. (dB)	Margin (dB)	Limit (dBµV)
0.334000	38.5	Off	L1	19.4	20.9	59.4
0.430000	38.6	Off	L1	19.5	18.7	57.3
1.286000	36.5	Off	L1	19.6	19.5	56.0
1.646000	39.9	Off	L1	19.6	16.1	56.0
1.926000	36.1	Off	L1	19.6	19.9	56.0
2.158000	38.5	Off	L1	19.7	17.5	56.0
2.286000	40.4	Off	L1	19.7	15.6	56.0
2.430000	42.4	Off	L1	19.7	13.6	56.0
2.598000	43.7	Off	L1	19.7	12.3	56.0
2.710000	44.9	Off	L1	19.7	11.1	56.0
2.878000	45.1	Off	L1	19.7	10.9	56.0
3.182000	42.8	Off	L1	19.7	13.2	56.0
3.454000	41.2	Off	L1	19.7	14.8	56.0
3.814000	41.1	Off	L1	19.7	14.9	56.0
4.054000	40.1	Off	L1	19.7	15.9	56.0
4.302000	40.1	Off	L1	19.7	15.9	56.0
4.478000	40.0	Off	L1	19.8	16.0	56.0
4.846000	39.8	Off	L1	19.7	16.2	56.0



Test Mode :	Mode 1	Temperature :	24~25°C
Test Engineer :	Kai-Chun Chu	Relative Humidity :	53~54%
Test Voltage :	120Vac / 60Hz	Phase :	Line
Function Type :	GSM1900 Idle + Bluetooth Link + WLAN (5GHz) Link + Earphone 2 + Battery + MP3 + USB Cable (Charging from Adapter) + SIM2		

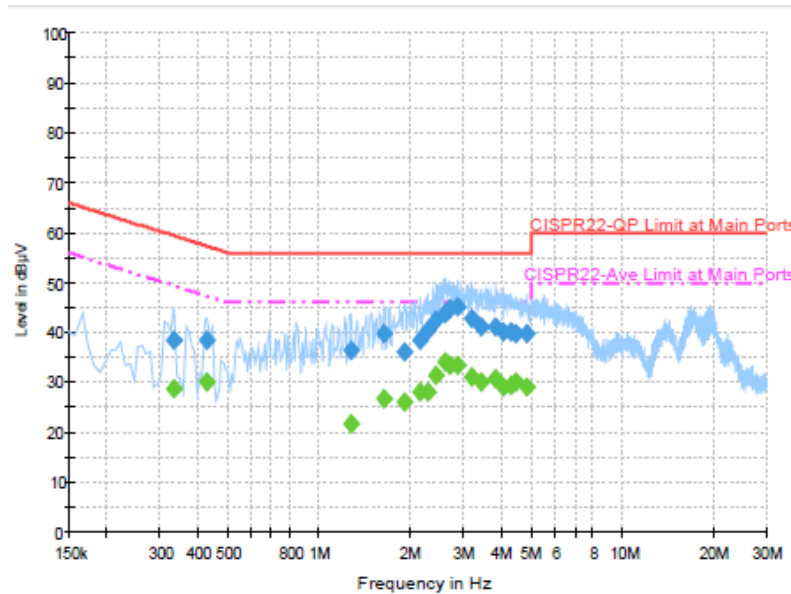

Final Result : Average

Frequency (MHz)	Average (dBµV)	Filter	Line	Corr. (dB)	Margin (dB)	Limit (dBµV)
0.334000	28.6	Off	L1	19.4	20.8	49.4
0.430000	30.2	Off	L1	19.5	17.1	47.3
1.286000	21.8	Off	L1	19.6	24.2	46.0
1.646000	26.9	Off	L1	19.6	19.1	46.0
1.926000	26.2	Off	L1	19.6	19.8	46.0
2.158000	28.0	Off	L1	19.7	18.0	46.0
2.286000	28.1	Off	L1	19.7	17.9	46.0
2.430000	31.5	Off	L1	19.7	14.5	46.0
2.598000	34.0	Off	L1	19.7	12.0	46.0
2.710000	33.4	Off	L1	19.7	12.6	46.0
2.878000	33.4	Off	L1	19.7	12.6	46.0
3.182000	31.1	Off	L1	19.7	14.9	46.0
3.454000	30.0	Off	L1	19.7	16.0	46.0
3.814000	30.6	Off	L1	19.7	15.4	46.0
4.054000	29.0	Off	L1	19.7	17.0	46.0
4.302000	29.3	Off	L1	19.7	16.7	46.0
4.478000	30.0	Off	L1	19.8	16.0	46.0
4.846000	29.0	Off	L1	19.7	17.0	46.0



Test Mode :	Mode 1	Temperature :	24~25°C
Test Engineer :	Kai-Chun Chu	Relative Humidity :	53~54%
Test Voltage :	120Vac / 60Hz	Phase :	Neutral
Function Type :	GSM1900 Idle + Bluetooth Link + WLAN (5GHz) Link + Earphone 2 + Battery + MP3 + USB Cable (Charging from Adapter) + SIM2		

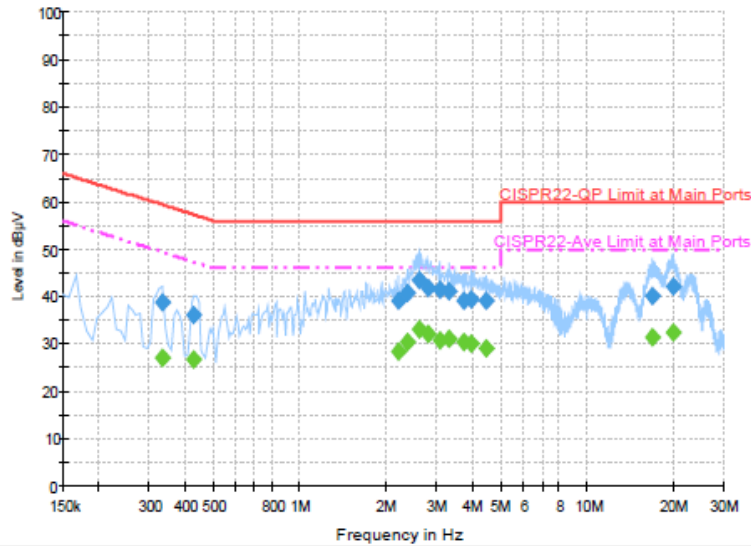

Final Result : QuasiPeak

Frequency (MHz)	QuasiPeak (dBµV)	Filter	Line	Corr. (dB)	Margin (dB)	Limit (dBµV)
0.334000	38.8	Off	N	19.4	20.6	59.4
0.430000	36.2	Off	N	19.5	21.1	57.3
2.214000	39.0	Off	N	19.7	17.0	56.0
2.374000	40.8	Off	N	19.7	15.2	56.0
2.598000	43.4	Off	N	19.6	12.6	56.0
2.806000	41.8	Off	N	19.7	14.2	56.0
3.094000	41.6	Off	N	19.7	14.4	56.0
3.318000	41.3	Off	N	19.7	14.7	56.0
3.750000	39.2	Off	N	19.7	16.8	56.0
3.982000	39.6	Off	N	19.7	16.4	56.0
4.478000	39.1	Off	N	19.7	16.9	56.0
16.862000	40.2	Off	N	20.0	19.8	60.0
19.918000	42.0	Off	N	20.1	18.0	60.0



Test Mode :	Mode 1	Temperature :	24~25°C
Test Engineer :	Kai-Chun Chu	Relative Humidity :	53~54%
Test Voltage :	120Vac / 60Hz	Phase :	Neutral
Function Type :	GSM1900 Idle + Bluetooth Link + WLAN (5GHz) Link + Earphone 2 + Battery + MP3 + USB Cable (Charging from Adapter) + SIM2		

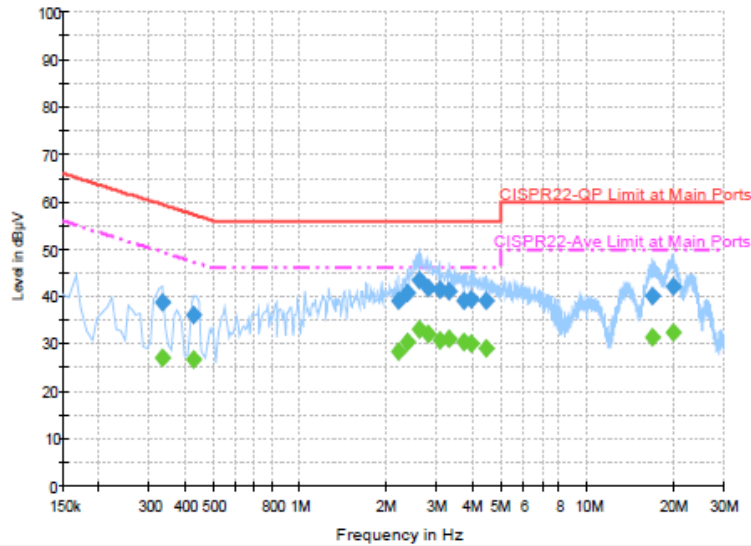

Final Result : Average

Frequency (MHz)	Average (dBµV)	Filter	Line	Corr. (dB)	Margin (dB)	Limit (dBµV)
0.334000	27.1	Off	N	19.4	22.3	49.4
0.430000	26.8	Off	N	19.5	20.5	47.3
2.214000	28.5	Off	N	19.7	17.5	46.0
2.374000	30.4	Off	N	19.7	15.6	46.0
2.598000	33.0	Off	N	19.6	13.0	46.0
2.806000	32.0	Off	N	19.7	14.0	46.0
3.094000	30.9	Off	N	19.7	15.1	46.0
3.318000	31.0	Off	N	19.7	15.0	46.0
3.750000	30.3	Off	N	19.7	15.7	46.0
3.982000	30.2	Off	N	19.7	15.8	46.0
4.478000	29.2	Off	N	19.7	16.8	46.0
16.862000	31.4	Off	N	20.0	18.6	50.0
19.918000	32.5	Off	N	20.1	17.5	50.0

3.6 Frequency Stability Measurement

3.6.1 Limit of Frequency Stability

Manufacturers of U-NII devices are responsible for ensuring frequency stability such that an emission is maintained within the band of operation under all conditions of normal operation as specified in the user's manual.

3.6.2 Measuring Instruments

The measuring equipment is listed in the section 4 of this test report.

3.6.3 Test Procedures

1. To ensure emission at the band edge is maintained within the authorized band, those values shall be measured by radiation emissions at upper and lower frequency points, and finally compensated by frequency deviation as procedures below.
2. The EUT was operated at the maximum output power, and connected to the spectrum analyzer, which is set to maximum hold function and peak detector. The peak value of the power envelope was measured and noted. The upper and lower frequency points were respectively measured relatively 10dB lower than the measured peak value.
3. The frequency deviation was calculated by adding the upper frequency point and the lower frequency point divided by two. Those detailed values of frequency deviation are provided in table below.

3.6.4 Test Setup



3.6.5 Test Result of Frequency Stability

Please refer to Appendix A.



3.7 Automatically Discontinue Transmission

3.7.1 Limit of Automatically Discontinue Transmission

The device shall automatically discontinue transmission in case of either absence of information to transmit or operational failure. These provisions are not intended to preclude the transmission of control or signaling information or the use of repetitive codes used by certain digital technologies to complete frame or burst intervals. Applicants shall include in their application for equipment authorization to describe how this requirement is met.

3.7.2 Measuring Instruments

The measuring equipment is listed in the section 4 of this test report.

3.7.3 Test Result of Automatically Discontinue Transmission

While the EUT is not transmitting any information, the EUT can automatically discontinue transmission and become standby mode for power saving. The EUT can detect the controlling signal of ACK message transmitting from remote device and verify whether it shall resend or discontinue transmission.



3.8 Antenna Requirements

3.8.1 Standard Applicable

According to FCC 47 CFR Section 15.407(a)(1)(2) ,if transmitting antenna directional gain is greater than 6 dBi, both the peak transmit power and the peak power spectral density shall be reduced by the amount in dB that the directional gain of the antenna exceeds 6 dBi.

3.8.2 Antenna Anti-Replacement Construction

An embedded-in antenna design is used.

3.8.3 Antenna Gain

The antenna gain is less than 6 dBi. Therefore, it is not necessary to reduce maximum peak output power limit.



4 List of Measuring Equipments

Instrument	Manufacturer	Model No.	Serial No.	Characteristics	Calibration Date	Test Date	Due Date	Remark
Power Meter	Anritsu	ML2495A	1218006	300MHz~40GHz	Oct. 18, 2014	May 04, 2015 ~ May 11, 2015	Oct. 17, 2015	Conducted (TH05-HY)
Power Sensor	Anritsu	MA2411B	1126017	300MHz~40GHz	Aug. 22, 2014	May 04, 2015 ~ May 11, 2015	Aug. 21, 2015	Conducted (TH05-HY)
Spectrum Analyzer	Rohde & Schwarz	FSP40	100057	9kHz~40GHz	Oct. 17, 2014	May 04, 2015 ~ May 11, 2015	Oct. 16, 2015	Conducted (TH05-HY)
Temperature Chamber	ESPEC	SU-241	92003713	-30 ~95 degree	Jun. 18, 2014	May 04, 2015 ~ May 11, 2015	Jun. 17, 2015	Conducted (TH05-HY)
Hygrometer	Testo	608-H2	41410069	N/A	Jul. 17, 2014	May 04, 2015 ~ May 11, 2015	Jul. 16, 2015	Conducted (TH05-HY)
RF cable	WOKEN	S05	S05-130708-038	N/A	Jan. 21, 2015	May 04, 2015 ~ May 11, 2015	Jan. 20, 2016	Conducted (TH05-HY)
Amplifier	SONOMA	310N	187312	9kHz~1GHz	Nov. 24, 2014	May 05, 2015 ~ May 12, 2015	Nov. 23, 2015	Radiation (03CH11-HY)
Bilog Antenna	TESEQ	CBL 6111D	35414	30MHz~1GHz	Oct. 24, 2014	May 05, 2015 ~ May 12, 2015	Oct. 23, 2015	Radiation (03CH11-HY)
Horn Antenna	SCHWARZBECK	BBHA 9120 D	9120D-1326	1GHz ~ 18GHz	Oct. 03, 2014	May 05, 2015 ~ May 12, 2015	Oct. 02, 2015	Radiation (03CH11-HY)
Hygrometer	TECPEL	DTN-303B	TP140325	N/A	Nov. 19, 2014	May 05, 2015 ~ May 12, 2015	Nov. 18, 2015	Radiation (03CH11-HY)
Preamplifier	Keysight	83017A	MY53270080	1GHz~26.5GHz	Nov. 20, 2014	May 05, 2015 ~ May 12, 2015	Nov. 19, 2015	Radiation (03CH11-HY)
Spectrum Analyzer	Keysight	N9010A	MY54200486	10Hz ~ 44GHZ	Sep. 24, 2014	May 05, 2015 ~ May 12, 2015	Sep. 23, 2015	Radiation (03CH11-HY)
RF Cable	HUBER + SUHNER	SUCOFLEX 104	MY24967/4 MY28419/4 MY28654/4	25GHz~40GHz	Nov. 06, 2014	May 05, 2015 ~ May 12, 2015	Nov. 05, 2015	Radiation (03CH11-HY)
RF Cable	HUBER + SUHNER	SUCOFLEX 104	MY24967/4 MY28419/4 MY28654/4	30MHz~1GHz	Nov. 06, 2014	May 05, 2015 ~ May 12, 2015	Nov. 05, 2015	Radiation (03CH11-HY)
RF Cable	HUBER + SUHNER	SUCOFLEX 104	MY24967/4 MY28419/4 MY28654/4	1GHz~25GHz	Nov. 06, 2014	May 05, 2015 ~ May 12, 2015	Nov. 05, 2015	Radiation (03CH11-HY)
Controller	EMEC	EM 1000	N/A	Control Turn table & Ant Mast	N/A	May 05, 2015 ~ May 12, 2015	N/A	Radiation (03CH11-HY)
Antenna Mast	EMEC	AM-BS-4500-B	N/A	1~4m	N/A	May 05, 2015 ~ May 12, 2015	N/A	Radiation (03CH11-HY)
Turn Table	EMEC	TT 2000	N/A	0-360 degree	N/A	May 05, 2015 ~ May 12, 2015	N/A	Radiation (03CH11-HY)
Preamplifier	MITEQ	AMF-7D-0010 1800-30-10P	1902247	1GHz~18GHz	Nov. 25, 2014	May 05, 2015 ~ May 12, 2015	Nov. 24, 2015	Radiation (03CH11-HY)
Preamplifier	MITEQ	JS44-1800400 0-33-8P	1840917	18GHz ~ 40GHz	Jun. 09, 2014	May 05, 2015 ~ May 12, 2015	Jun. 08, 2015	Radiation (03CH11-HY)
Loop Antenna	Rohde & Schwarz	HFH2-Z2	100315	9 kHz~30 MHz	Jul. 28, 2014	May 05, 2015 ~ May 12, 2015	Jul. 27, 2015	Radiation (03CH11-HY)



Instrument	Manufacturer	Model No.	Serial No.	Characteristics	Calibration Date	Test Date	Due Date	Remark
Horn Antenna	SCHWARZBECK	BBHA 9170	BBHA9170584	18GHz- 40GHz	Nov. 03, 2014	May 05, 2015~ May 12, 2015	Nov. 02, 2015	Radiation (03CH11-HY)
EMI Test Receiver	Keysight	N9038A	MY54130085	20Hz ~ 26.5GHz	Nov. 05, 2014	May 05, 2015~ May 12, 2015	Nov. 04, 2015	Radiation (03CH11-HY)
RF Cable	HUBER + SUHNER	SUCOFLEX 104	MY84209521	9KHz~1GHz	Dec. 04, 2014	May 05, 2015 ~ May 12, 2015	Dec. 03, 2015	Radiation (03CH11-HY)
Filter	Wainwright	WLKS1200-8S	SN3	1.2G Low Pass	Oct. 01, 2014	May 05, 2015 ~ May 12, 2015	Sep. 30, 2015	Radiation (03CH11-HY)
Filter	Microwave	H3G018G1	SN477220	3.0G High Pass	Oct. 01, 2014	May 05, 2015 ~ May 12, 2015	Sep. 30, 2015	Radiation (03CH11-HY)
Test Software	Audix	E3	6.2009-8-24	N/A	N/A	May 05, 2015 ~ May 12, 2015	N/A	Radiation (03CH11-HY)
AC Power Source	ChainTek	APC-1000W	N/A	N/A	N/A	May 10, 2015	N/A	Conduction (CO05-HY)
EMI Test Receiver	Rohde & Schwarz	ESCS 30	100356	9kHz – 2.75GHz	Dec. 01, 2014	May 10, 2015	Nov. 30, 2015	Conduction (CO05-HY)
Hygrometer	Testo	608-H1	34913912	N/A	Apr. 20, 2015	May 10, 2015	Apr. 19, 2016	Conduction (CO05-HY)
LISN	Rohde & Schwarz	ENV216	100080	9kHz~30MHz	Dec. 02, 2014	May 10, 2015	Dec. 01, 2015	Conduction (CO05-HY)
LF Cable	HUBER + SUHNER	RG-214/U	LF01	N/A	Jan. 02, 2015	May 10, 2015	Jan. 01, 2016	Conduction (CO05-HY)
Test Software	N/A	EMC32	8.40.0	N/A	N/A	May 10, 2015	N/A	Conduction (CO05-HY)



5 Uncertainty of Evaluation

Uncertainty of Conducted Emission Measurement (150kHz ~ 30MHz)

Measuring Uncertainty for a Level of Confidence of 95% ($U = 2Uc(y)$)	2.26
---	------

Uncertainty of Radiated Emission Measurement (30 MHz ~ 1000 MHz)

Measuring Uncertainty for a Level of Confidence of 95% ($U = 2Uc(y)$)	4.90
---	------



Appendix A. Conducted Test Results

Test Engineer:	Derek Hsu	Temperature:	21~25	°C
Test Date:	2015/05/04~2015/05/11	Relative Humidity:	51~54	%

TEST RESULTS DATA
26dB and 99% OBW

Band I										
Mod.	Data Rate	NTX	CH.	Freq. (MHz)	99% Bandwidth (MHz)	26 dB Bandwidth (MHz)	IC 99% Bandwidth Power Limit (dBm)	IC 99% Bandwidth EIRP Limit (dBm)		
11a	6Mbps	1	36	5180	17.70	21.45	-	22.48		
11a	6Mbps	1	44	5220	17.70	21.50	-	22.48		
11a	6Mbps	1	48	5240	17.70	21.40	-	22.48		
HT20	MCS0	1	36	5180	18.50	21.80	-	22.67		
HT20	MCS0	1	44	5220	18.45	21.75	-	22.66		
HT20	MCS0	1	48	5240	18.45	22.05	-	22.66		
HT40	MCS0	1	38	5190	36.50	41.31	-	23.01		
HT40	MCS0	1	46	5230	36.50	41.22	-	23.01		

TEST RESULTS DATA
Average Power Table

FCC Band I										
Mod.	Data Rate	NTX	CH.	Freq. (MHz)	Duty Factor (dB)	Average Conducted Power (dBm)	FCC Conducted Power Limit (dBm)	DG (dBi)		Pass/Fail
11a	6Mbps	1	36	5180	0.53	11.48	24.00	-1.60		Pass
11a	6Mbps	1	44	5220	0.53	11.46	24.00	-1.60		Pass
11a	6Mbps	1	48	5240	0.53	11.47	24.00	-1.60		Pass
HT20	MCS0	1	36	5180	0.53	11.34	24.00	-1.60		Pass
HT20	MCS0	1	44	5220	0.53	11.33	24.00	-1.60		Pass
HT20	MCS0	1	48	5240	0.53	11.42	24.00	-1.60		Pass
HT40	MCS0	1	38	5190	0.99	10.87	24.00	-1.60		Pass
HT40	MCS0	1	46	5230	0.99	11.05	24.00	-1.60		Pass

TEST RESULTS DATA
Power Spectral Density

FCC Band I										
Mod.	Data Rate	NTX	CH.	Freq. (MHz)	Duty Factor (dB)	Average Power Density (dBm/MHz)	Average PSD Limit (dBm/MHz)	DG (dBi)	-	Pass/Fail
11a	6Mbps	1	36	5180	0.53	1.21	11.00	-1.60		Pass
11a	6Mbps	1	44	5220	0.53	1.21	11.00	-1.60		Pass
11a	6Mbps	1	48	5240	0.53	0.52	11.00	-1.60		Pass
HT20	MCS0	1	36	5180	0.53	0.82	11.00	-1.60		Pass
HT20	MCS0	1	44	5220	0.53	0.84	11.00	-1.60		Pass
HT20	MCS0	1	48	5240	0.53	0.72	11.00	-1.60		Pass
HT40	MCS0	1	38	5190	0.99	-2.93	11.00	-1.60		Pass
HT40	MCS0	1	46	5230	0.99	-2.40	11.00	-1.60		Pass

TEST RESULTS DATA
26dB and 99% OBW

Band II										
Mod.	Data Rate	NTX	CH.	Freq. (MHz)	99% Bandwidth (MHz)	26 dB Bandwidth (MHz)	IC 99% Bandwidth Power Limit (dBm)	IC 99% Bandwidth EIRP Limit (dBm)	FCC 26dB Bandwidth Power Limit (dBm)	Note
11a	6M bps	1	52	5260	17.65	21.4	23.47	29.47	23.98	
11a	6M bps	1	60	5300	17.75	21.4	23.49	29.49	23.98	
11a	6M bps	1	64	5320	17.65	21.2	23.47	29.47	23.98	
HT20	MCS 0	1	52	5260	18.55	21.85	23.68	29.68	23.98	
HT20	MCS 0	1	60	5300	18.55	21.75	23.68	29.68	23.98	
HT20	MCS 0	1	64	5320	18.45	22	23.66	29.66	23.98	
HT40	MCS 0	1	54	5270	36.5	41.31	23.98	30.00	23.98	
HT40	MCS 0	1	62	5310	36.5	41.04	23.98	30.00	23.98	

TEST RESULTS DATA
Average Power Table

FCC Band II										
Mod.	Data Rate	NTX	CH.	Freq. (MHz)	Duty Factor (dB)	Average Conducted Power (dBm)	FCC Conducted Power Limit (dBm)	DG (dBi)		Pass/Fail
11a	6M bps	1	52	5260	0.53	11.47	23.98	-1.50		Pass
11a	6M bps	1	60	5300	0.53	11.41	23.98	-1.50		Pass
11a	6M bps	1	64	5320	0.53	11.14	23.98	-1.50		Pass
HT20	MCS 0	1	52	5260	0.53	11.44	23.98	-1.50		Pass
HT20	MCS 0	1	60	5300	0.53	11.49	23.98	-1.50		Pass
HT20	MCS 0	1	64	5320	0.53	11.14	23.98	-1.50		Pass
HT40	MCS 0	1	54	5270	0.99	11.46	23.98	-1.50		Pass
HT40	MCS 0	1	62	5310	0.99	11.00	23.98	-1.50		Pass

TEST RESULTS DATA
Power Spectral Density

Band II										
Mod.	Data Rate	NTX	CH.	Freq. (MHz)	Duty Factor (dB)	Average Power Density (dBm/MHz)	Average PSD Limit (dBm/MHz)	DG (dBi)		Pass/Fail
11a	6M bps	1	52	5260	0.53	1.23	11.00	-1.50		Pass
11a	6M bps	1	60	5300	0.53	1.24	11.00	-1.50		Pass
11a	6M bps	1	64	5320	0.53	1.59	11.00	-1.50		Pass
HT20	MCS 0	1	52	5260	0.53	0.72	11.00	-1.50		Pass
HT20	MCS 0	1	60	5300	0.53	1.06	11.00	-1.50		Pass
HT20	MCS 0	1	64	5320	0.53	1.09	11.00	-1.50		Pass
HT40	MCS 0	1	54	5270	0.99	-1.90	11.00	-1.50		Pass
HT40	MCS 0	1	62	5310	0.99	-2.40	11.00	-1.50		Pass

TEST RESULTS DATA
26dB and 99% OBW

Band III										
Mod.	Data Rate	NTX	CH.	Freq. (MHz)	99% Bandwidth (MHz)	26 dB Bandwidth (MHz)	IC 99% Bandwidth Power Limit (dBm)	IC 99% Bandwidth EIRP Limit (dBm)	FCC 26dB Bandwidth Power Limit (dBm)	Note
11a	6M bps	1	100	5500	17.7	21.3	23.48	29.48	23.98	
11a	6M bps	1	116	5580	17.75	21.35	23.49	29.49	23.98	
11a	6M bps	1	140	5700	17.5	21.25	23.43	29.43	23.98	
HT20	MCS 0	1	100	5500	18.4	21.65	23.65	29.65	23.98	
HT20	MCS 0	1	116	5580	18.35	21.75	23.64	29.64	23.98	
HT20	MCS 0	1	140	5700	18.45	21.7	23.66	29.66	23.98	
HT40	MCS 0	1	102	5510	36.5	41.22	23.98	30.00	23.98	
HT40	MCS 0	1	110	5550	36.6	41.31	23.98	30.00	23.98	
HT40	MCS 0	1	134	5670	36.6	41.22	23.98	30.00	23.98	

TEST RESULTS DATA
Average Power Table

FCC Band III										
Mod.	Data Rate	NTX	CH.	Freq. (MHz)	Duty Factor (dB)	Average Conducted Power (dBm)	FCC Conducted Power Limit (dBm)	DG (dBi)		Pass/Fail
11a	6M bps	1	100	5500	0.53	11.16	23.98	-1.50		Pass
11a	6M bps	1	116	5580	0.53	11.44	23.98	-1.50		Pass
11a	6M bps	1	140	5700	0.53	11.49	23.98	-1.50		Pass
HT20	MCS 0	1	100	5500	0.53	11.44	23.98	-1.50		Pass
HT20	MCS 0	1	116	5580	0.53	11.48	23.98	-1.50		Pass
HT20	MCS 0	1	140	5700	0.53	11.08	23.98	-1.50		Pass
HT40	MCS 0	1	102	5510	0.99	10.96	23.98	-1.50		Pass
HT40	MCS 0	1	110	5550	0.99	11.32	23.98	-1.50		Pass
HT40	MCS 0	1	134	5670	0.99	11.35	23.98	-1.50		Pass

TEST RESULTS DATA
Power Spectral Density

Band III										
Mod.	Data Rate	NTX	CH.	Freq. (MHz)	Duty Factor (dB)	Average Power Density (dBm/MHz)	Average PSD Limit (dBm/MHz)	DG (dBi)		Pass/Fail
11a	6M bps	1	100	5500	0.53	0.56	11.00	-1.50		Pass
11a	6M bps	1	116	5580	0.53	1.62	11.00	-1.50		Pass
11a	6M bps	1	140	5700	0.53	0.75	11.00	-1.50		Pass
HT20	MCS 0	1	100	5500	0.53	0.36	11.00	-1.50		Pass
HT20	MCS 0	1	116	5580	0.53	0.39	11.00	-1.50		Pass
HT20	MCS 0	1	140	5700	0.53	0.37	11.00	-1.50		Pass
HT40	MCS 0	1	102	5510	0.99	-2.76	11.00	-1.50		Pass
HT40	MCS 0	1	110	5550	0.99	-2.33	11.00	-1.50		Pass
HT40	MCS 0	1	134	5670	0.99	-2.22	11.00	-1.50		Pass

TEST RESULTS DATA
Frequency Stability

Band I										
Mod.	Data Rate	NTX	CH.	Freq. (MHz)	Center Frequency (MHz)	Frequency Deviation (MHz)	Frequency Stability (ppm)	Temperature (°C)	Voltage (V)	Note
11a	6Mbps	1	36	5180	5180.000	0.000	0.00	20	3.5	
11a	6Mbps	1	36	5180	5180.000	0.000	0.00	20	4.1	
11a	6Mbps	1	36	5180	5180.032	0.032	6.19	20	3.7	
11a	6Mbps	1	36	5180	5180.000	0.000	0.00	-30	3.7	
11a	6Mbps	1	36	5180	5180.000	0.000	0.00	50	3.7	

Band II										
Mod.	Data Rate	NTX	CH.	Freq. (MHz)	Center Frequency (MHz)	Frequency Deviation (MHz)	Frequency Stability (ppm)	Temperature (°C)	Voltage (V)	Note
11a	6Mbps	1	64	5320	5319.984	-0.016	-3.01	20	3.5	
11a	6Mbps	1	64	5320	5320.008	0.008	1.51	20	4.1	
11a	6Mbps	1	64	5320	5320.016	0.016	3.01	20	3.7	
11a	6Mbps	1	64	5320	5320.000	0.000	0.00	-30	3.7	
11a	6Mbps	1	64	5320	5320.000	0.000	0.00	50	3.7	

Band III										
Mod.	Data Rate	NTX	CH.	Freq. (MHz)	Center Frequency (MHz)	Frequency Deviation (MHz)	Frequency Stability (ppm)	Temperature (°C)	Voltage (V)	Note
11a	6Mbps	1	100	5500	5500.048	0.048	8.74	20	3.5	
11a	6Mbps	1	100	5500	5500.048	0.048	8.74	20	4.1	
11a	6Mbps	1	100	5500	5500.048	0.048	8.74	20	3.7	
11a	6Mbps	1	100	5500	5500.000	0.000	0.00	-30	3.7	
11a	6Mbps	1	100	5500	5500.000	0.000	0.00	50	3.7	



Appendix B. Radiated Spurious Emission

Test Engineer :	Jesse Wang and Derreck Chen	Temperature :	23~24°C
		Relative Humidity :	46~48%

Band 1 5150~5250MHz

WIFI 802.11a (Band Edge @ 3m)

WIFI Ant. 1	Note	Frequency (MHz)	Level (dBμV/m)	Over Limit (dB)	Limit Line (dBμV/m)	Read Level (dBμV)	Antenna Factor (dB/m)	Cable Loss (dB)	Preamp Factor (dB)	Ant Pos (cm)	Table Pos (deg)	Peak Avg. (P/A)	Pol. (H/V)	
802.11a CH 36 5180MHz		5141.6	54.05	-19.95	74	46.92	31.72	8.95	33.54	102	272	P	H	
		5149.55	45.82	-8.18	54	38.69	31.72	8.95	33.54	102	272	A	H	
	*	5182	105.35	-	-	98.17	31.75	8.97	33.54	102	272	P	H	
	*	5182	98.24	-	-	91.06	31.75	8.97	33.54	102	272	A	H	
													H	
														H
			5144.45	52.57	-21.43	74	45.44	31.72	8.95	33.54	254	279	P	V
			5146.7	43.93	-10.07	54	36.8	31.72	8.95	33.54	254	279	A	V
	*		5178	102.61	-	-	95.43	31.75	8.97	33.54	254	279	P	V
	*		5178	95.19	-	-	88.01	31.75	8.97	33.54	254	279	A	V
														V
														V
802.11a CH 44 5220MHz		5141.15	52.66	-21.34	74	45.53	31.72	8.95	33.54	103	271	P	H	
		5139.95	45.02	-8.98	54	37.89	31.72	8.95	33.54	103	271	A	H	
	*	5222	105.94	-	-	98.73	31.77	8.98	33.54	103	271	P	H	
	*	5222	98.4	-	-	91.19	31.77	8.98	33.54	103	271	A	H	
			5373.43	49.62	-24.38	74	42.15	31.89	9.13	33.55	103	271	P	H
			5372.33	42.23	-11.77	54	34.75	31.89	9.13	33.54	103	271	A	H
			5128.85	50.5	-23.5	74	43.38	31.71	8.95	33.54	251	279	P	V
			5139.95	42.86	-11.14	54	35.73	31.72	8.95	33.54	251	279	A	V
	*		5218	102.29	-	-	95.08	31.77	8.98	33.54	251	279	P	V
	*		5218	95.31	-	-	88.1	31.77	8.98	33.54	251	279	A	V
			5367	48.13	-25.87	74	40.65	31.89	9.13	33.54	251	279	P	V
			5373.43	40.13	-13.87	54	32.66	31.89	9.13	33.55	251	279	A	V



802.11a CH 48 5240MHz		5136.5	52.68	-21.32	74	45.56	31.71	8.95	33.54	100	272	P	H
		5087	43.22	-10.78	54	36.16	31.67	8.92	33.53	100	272	A	H
	*	5238	105.75	-	-	98.52	31.79	8.98	33.54	100	272	P	H
	*	5238	98.51	-	-	91.28	31.79	8.98	33.54	100	272	A	H
		5350.55	49.95	-24.05	74	42.53	31.88	9.08	33.54	100	272	P	H
		5392.13	42.2	-11.8	54	34.71	31.91	9.13	33.55	100	272	A	H
		5148.95	50.58	-23.42	74	43.45	31.72	8.95	33.54	261	278	P	V
		5087.45	41.5	-12.5	54	34.44	31.67	8.92	33.53	261	278	A	V
	*	5242	102.87	-	-	95.62	31.8	8.99	33.54	261	278	P	V
	*	5242	95.08	-	-	87.83	31.8	8.99	33.54	261	278	A	V
		5369.91	49.12	-24.88	74	41.64	31.89	9.13	33.54	261	278	P	V
		5393.23	40.06	-13.94	54	32.57	31.91	9.13	33.55	261	278	A	V
Remark	1. No other spurious found. 2. All results are PASS against Peak and Average limit line.												



Band 1 5150~5250MHz

WIFI 802.11a (Harmonic @ 3m)

WIFI Ant. 1	Note	Frequency (MHz)	Level (dBμV/m)	Over Limit (dB)	Limit Line (dBμV/m)	Read Level (dBμV)	Antenna Factor (dB/m)	Cable Loss (dB)	Preamp Factor (dB)	Ant Pos (cm)	Table Pos (deg)	Peak Avg. (P/A)	Pol. (H/V)
802.11a CH 36 5180MHz		10360	44.98	-29.02	74	26.09	39.94	13.09	34.14	100	0	P	H
		15540	44.59	-29.41	74	25.49	38.33	16.55	35.78	100	0	P	H
													H
													H
		10360	44.89	-29.11	74	26	39.94	13.09	34.14	100	0	P	V
		15540	45	-29	74	25.9	38.33	16.55	35.78	100	0	P	V
													V
													V
802.11a CH 44 5220MHz		10440	45.62	-28.38	74	26.63	40.02	13.11	34.14	100	0	P	H
		15660	45.67	-28.33	74	26.82	38.09	16.56	35.8	100	0	P	H
													H
													H
		10440	45.4	-28.6	74	26.41	40.02	13.11	34.14	100	0	P	V
		15660	44.72	-29.28	74	25.87	38.09	16.56	35.8	100	0	P	V
													V
													V
802.11a CH 48 5240MHz		10480	46.06	-27.94	74	27.01	40.08	13.11	34.14	100	0	P	H
		15720	44.52	-29.48	74	25.8	37.95	16.57	35.8	100	0	P	H
													H
													H
		10480	45.24	-28.76	74	26.19	40.08	13.11	34.14	100	0	P	V
		15720	44.28	-29.72	74	25.56	37.95	16.57	35.8	100	0	P	V
													V
													V
Remark	1. No other spurious found. 2. All results are PASS against Peak and Average limit line.												



Band 1 5150~5250MHz

WIFI 802.11n HT20 (Band Edge @ 3m)

WIFI Ant. 1	Note	Frequency (MHz)	Level (dBμV/m)	Over Limit (dB)	Limit Line (dBμV/m)	Read Level (dBμV)	Antenna Factor (dB/m)	Cable Loss (dB)	Preamp Factor (dB)	Ant Pos (cm)	Table Pos (deg)	Peak Avg. (P/A)	Pol. (H/V)	
802.11n HT20 CH 36 5180MHz		5136.95	55.08	-18.92	74	47.96	31.71	8.95	33.54	104	273	P	H	
		5149.85	45.81	-8.19	54	38.68	31.72	8.95	33.54	104	273	A	H	
	*	5182	105.69	-	-	98.51	31.75	8.97	33.54	104	273	P	H	
	*	5182	97.92	-	-	90.74	31.75	8.97	33.54	104	273	A	H	
													H	
														H
			5144.3	52.64	-21.36	74	45.51	31.72	8.95	33.54	100	274	P	V
			5147.9	43.29	-10.71	54	36.16	31.72	8.95	33.54	100	274	A	V
		*	5182	101.52	-	-	94.34	31.75	8.97	33.54	100	274	P	V
		*	5182	93.89	-	-	86.71	31.75	8.97	33.54	100	274	A	V
													V	
													V	
802.11n HT20 CH 44 5220MHz		5145	52.82	-21.18	74	45.69	31.72	8.95	33.54	104	271	P	H	
		5139.95	44.7	-9.3	54	37.57	31.72	8.95	33.54	104	271	A	H	
	*	5220	105.76	-	-	98.55	31.77	8.98	33.54	104	271	P	H	
	*	5220	98.11	-	-	90.9	31.77	8.98	33.54	104	271	A	H	
			5373.87	49.06	-24.94	74	41.59	31.89	9.13	33.55	104	271	P	H
			5371.89	42.59	-11.41	54	35.11	31.89	9.13	33.54	104	271	A	H
			5126.75	50.38	-23.62	74	43.26	31.71	8.95	33.54	102	273	P	V
			5140.1	42.47	-11.53	54	35.34	31.72	8.95	33.54	102	273	A	V
		*	5219	101.49	-	-	94.28	31.77	8.98	33.54	102	273	P	V
		*	5219	94.45	-	-	87.24	31.77	8.98	33.54	102	273	A	V
		5350.66	49.07	-24.93	74	41.65	31.88	9.08	33.54	102	273	P	V	
		5371.56	40.34	-13.66	54	32.86	31.89	9.13	33.54	102	273	A	V	



802.11n HT20 CH 48 5240MHz		5146.4	52.04	-21.96	74	44.91	31.72	8.95	33.54	100	271	P	H
		5088.2	43.3	-10.7	54	36.24	31.67	8.92	33.53	100	271	A	H
	*	5238	105.47	-	-	98.24	31.79	8.98	33.54	100	271	P	H
	*	5238	98.28	-	-	91.05	31.79	8.98	33.54	100	271	A	H
		5355.61	51.01	-22.99	74	43.59	31.88	9.08	33.54	100	271	P	H
		5391.91	42.49	-11.51	54	35	31.91	9.13	33.55	100	271	A	H
		5147.9	51.48	-22.52	74	44.35	31.72	8.95	33.54	119	246	P	V
		5087.3	41.38	-12.62	54	34.32	31.67	8.92	33.53	119	246	A	V
	*	5239	102.55	-	-	95.32	31.79	8.98	33.54	119	246	P	V
	*	5239	95.06	-	-	87.83	31.79	8.98	33.54	119	246	A	V
		5404.78	48.59	-25.41	74	41.05	31.92	9.17	33.55	119	246	P	V
		5391.8	40.65	-13.35	54	33.16	31.91	9.13	33.55	119	246	A	V
Remark	1. No other spurious found. 2. All results are PASS against Peak and Average limit line.												



Band 1 5150~5250MHz

WIFI 802.11n HT20 (Harmonic @ 3m)

WIFI Ant. 1	Note	Frequency (MHz)	Level (dBμV/m)	Over Limit (dB)	Limit Line (dBμV/m)	Read Level (dBμV)	Antenna Factor (dB/m)	Cable Loss (dB)	Preamp Factor (dB)	Ant Pos (cm)	Table Pos (deg)	Peak Avg. (P/A)	Pol. (H/V)
802.11n HT20 CH 36 5180MHz		10360	48.44	-25.56	74	29.55	39.94	13.09	34.14	100	0	P	H
		15540	47.4	-26.6	74	28.3	38.33	16.55	35.78	100	0	P	H
													H
													H
		10360	46.93	-27.07	74	28.04	39.94	13.09	34.14	100	0	P	V
		15540	45.75	-28.25	74	26.65	38.33	16.55	35.78	100	0	P	V
													V
802.11n HT20 CH 44 5220MHz		10440	47.19	-26.81	74	28.2	40.02	13.11	34.14	100	0	P	H
		15660	46.33	-27.67	74	27.48	38.09	16.56	35.8	100	0	P	H
													H
													H
		10440	47.02	-26.98	74	28.03	40.02	13.11	34.14	100	0	P	V
		15660	46.62	-27.38	74	27.77	38.09	16.56	35.8	100	0	P	V
													V
802.11n HT20 CH 48 5240MHz		10480	47.77	-26.23	74	28.72	40.08	13.11	34.14	100	0	P	H
		15720	46.24	-27.76	74	27.52	37.95	16.57	35.8	100	0	P	H
													H
													H
		10480	47.29	-26.71	74	28.24	40.08	13.11	34.14	100	0	P	V
		15720	46.27	-27.73	74	27.55	37.95	16.57	35.8	100	0	P	V
													V
Remark	1. No other spurious found. 2. All results are PASS against Peak and Average limit line.												



Band 1 5150~5250MHz

WIFI 802.11n HT40 (Band Edge @ 3m)

WIFI Ant. 1	Note	Frequency (MHz)	Level (dBμV/m)	Over Limit (dB)	Limit Line (dBμV/m)	Read Level (dBμV)	Antenna Factor (dB/m)	Cable Loss (dB)	Preamp Factor (dB)	Ant Pos (cm)	Table Pos (deg)	Peak Avg. (P/A)	Pol. (H/V)
802.11n HT40 CH 38 5190MHz		5150	61.56	-12.44	74	54.43	31.72	8.95	33.54	100	282	P	H
		5150	50.28	-3.72	54	43.15	31.72	8.95	33.54	100	282	A	H
	*	5202	100.73	-	-	93.53	31.76	8.98	33.54	100	282	P	H
	*	5202	94.13	-	-	86.93	31.76	8.98	33.54	100	282	A	H
		5352.75	48.54	-25.46	74	41.12	31.88	9.08	33.54	100	282	P	H
		5367.71	40.69	-13.31	54	33.21	31.89	9.13	33.54	100	282	A	H
		5146.85	57.4	-16.6	74	50.27	31.72	8.95	33.54	100	188	P	V
		5148.8	47.47	-6.53	54	40.34	31.72	8.95	33.54	100	188	A	V
	*	5196	96.75	-	-	89.56	31.76	8.97	33.54	100	188	P	V
	*	5196	89.61	-	-	82.42	31.76	8.97	33.54	100	188	A	V
		5372	47.58	-26.42	74	40.1	31.89	9.13	33.54	100	188	P	V
		5428.1	39.76	-14.24	54	32.21	31.93	9.17	33.55	100	188	A	V
802.11n HT40 CH 46 5230MHz		5121.35	51.65	-22.35	74	44.58	31.69	8.92	33.54	100	282	P	H
		5149.55	42.81	-11.19	54	35.68	31.72	8.95	33.54	100	282	A	H
	*	5232	102.12	-	-	94.89	31.79	8.98	33.54	100	282	P	H
	*	5232	95.04	-	-	87.81	31.79	8.98	33.54	100	282	A	H
		5422.16	49.68	-24.32	74	42.13	31.93	9.17	33.55	100	282	P	H
		5375.96	41.99	-12.01	54	34.52	31.89	9.13	33.55	100	282	A	H
		5141.45	51.27	-22.73	74	44.14	31.72	8.95	33.54	100	187	P	V
		5148.2	41.2	-12.8	54	34.07	31.72	8.95	33.54	100	187	A	V
	*	5213	97.14	-	-	89.93	31.77	8.98	33.54	100	187	P	V
	*	5213	90.16	-	-	82.95	31.77	8.98	33.54	100	187	A	V
	5389.16	48.7	-25.3	74	41.21	31.91	9.13	33.55	100	187	P	V	
	5377.94	40.41	-13.59	54	32.92	31.91	9.13	33.55	100	187	A	V	

Remark
 1. No other spurious found.
 2. All results are PASS against Peak and Average limit line.



Band 1 5150~5250MHz

WIFI 802.11n HT40 (Harmonic @ 3m)

WIFI Ant. 1	Note	Frequency (MHz)	Level (dBμV/m)	Over Limit (dB)	Limit Line (dBμV/m)	Read Level (dBμV)	Antenna Factor (dB/m)	Cable Loss (dB)	Preamp Factor (dB)	Ant Pos (cm)	Table Pos (deg)	Peak Avg. (P/A)	Pol. (H/V)
802.11n HT40 CH 38 5190MHz		10380	47.35	-26.65	74	28.44	39.96	13.09	34.14	100	0	P	H
		15570	45.85	-28.15	74	26.83	38.26	16.55	35.79	100	0	P	H
													H
													H
		10380	46.55	-27.45	74	27.64	39.96	13.09	34.14	100	0	P	V
		15570	45.94	-28.06	74	26.92	38.26	16.55	35.79	100	0	P	V
													V
802.11n HT40 CH 46 5230MHz		10460	47.51	-26.49	74	28.5	40.04	13.11	34.14	100	0	P	H
		15690	45.86	-28.14	74	27.08	38.02	16.56	35.8	100	0	P	H
													H
													H
		10460	46.54	-27.46	74	27.53	40.04	13.11	34.14	100	0	P	V
		15690	46.78	-27.22	74	28	38.02	16.56	35.8	100	0	P	V
													V
Remark	1. No other spurious found.												
	2. All results are PASS against Peak and Average limit line.												



Band 2 5250~5350MHz

WIFI 802.11a (Band Edge @ 3m)

WIFI Ant. 1	Note	Frequency (MHz)	Level (dBμV/m)	Over Limit (dB)	Limit Line (dBμV/m)	Read Level (dBμV)	Antenna Factor (dB/m)	Cable Loss (dB)	Preamp Factor (dB)	Ant Pos (cm)	Table Pos (deg)	Peak Avg. (P/A)	Pol. (H/V)
802.11a CH 52 5260MHz		5106.8	52.03	-21.97	74	44.95	31.69	8.92	33.53	100	271	P	H
		5107.25	42.96	-11.04	54	35.88	31.69	8.92	33.53	100	271	A	H
	*	5262	105.28	-	-	98.02	31.81	8.99	33.54	100	271	P	H
	*	5262	97.98	-	-	90.72	31.81	8.99	33.54	100	271	A	H
		5356.05	50.66	-23.34	74	43.24	31.88	9.08	33.54	100	271	P	H
		5350.55	42.25	-11.75	54	34.83	31.88	9.08	33.54	100	271	A	H
		5108.15	50.16	-23.84	74	43.08	31.69	8.92	33.53	245	277	P	V
		5108	41.45	-12.55	54	34.37	31.69	8.92	33.53	245	277	A	V
	*	5262	102.57	-	-	95.31	31.81	8.99	33.54	245	277	P	V
	*	5262	95.11	-	-	87.85	31.81	8.99	33.54	245	277	A	V
		5426.34	49.05	-24.95	74	41.5	31.93	9.17	33.55	245	277	P	V
		5412.59	40.39	-13.61	54	32.84	31.93	9.17	33.55	245	277	A	V
802.11a CH 60 5300MHz		5087.6	51.31	-22.69	74	44.25	31.67	8.92	33.53	100	270	P	H
		5147	42.93	-11.07	54	35.8	31.72	8.95	33.54	100	270	A	H
	*	5299	105.84	-	-	98.5	31.84	9.04	33.54	100	270	P	H
	*	5299	98.31	-	-	90.97	31.84	9.04	33.54	100	270	A	H
		5354.62	54.59	-19.41	74	47.17	31.88	9.08	33.54	100	270	P	H
		5350	45.78	-8.22	54	38.36	31.88	9.08	33.54	100	270	A	H
		5135	51.64	-22.36	74	44.52	31.71	8.95	33.54	242	276	P	V
		5147.75	41.43	-12.57	54	34.3	31.72	8.95	33.54	242	276	A	V
	*	5302	102.27	-	-	94.93	31.84	9.04	33.54	242	276	P	V
	*	5302	94.79	-	-	87.45	31.84	9.04	33.54	242	276	A	V
		5351.54	51.15	-22.85	74	43.73	31.88	9.08	33.54	242	276	P	V
		5351.98	42.66	-11.34	54	35.24	31.88	9.08	33.54	242	276	A	V



802.11a CH 64 5320MHz	*	5318	105.17	-	-	97.82	31.85	9.04	33.54	100	271	P	H
	*	5318	98.37	-	-	91.02	31.85	9.04	33.54	100	271	A	H
		5351.76	55.09	-18.91	74	47.67	31.88	9.08	33.54	100	271	P	H
		5350.33	47.06	-6.94	54	39.64	31.88	9.08	33.54	100	271	A	H
													H
													H
	*	5318	102.12	-	-	94.77	31.85	9.04	33.54	100	271	P	V
	*	5318	94.83	-	-	87.48	31.85	9.04	33.54	100	271	A	V
		5355.28	52.13	-21.87	74	44.71	31.88	9.08	33.54	100	271	P	V
		5350.44	44.07	-9.93	54	36.65	31.88	9.08	33.54	100	271	A	V
													V
													V
Remark	1. No other spurious found. 2. All results are PASS against Peak and Average limit line.												



Band 2 5250~5350MHz

WIFI 802.11a (Harmonic @ 3m)

WIFI Ant. 1	Note	Frequency (MHz)	Level (dBμV/m)	Over Limit (dB)	Limit Line (dBμV/m)	Read Level (dBμV)	Antenna Factor (dB/m)	Cable Loss (dB)	Preamp Factor (dB)	Ant Pos (cm)	Table Pos (deg)	Peak Avg. (P/A)	Pol. (H/V)
802.11a CH 52 5260MHz		10520	46.37	-27.63	74	27.26	40.11	13.14	34.14	100	0	P	H
		15780	44.26	-29.74	74	25.65	37.85	16.57	35.81	100	0	P	H
													H
													H
		10520	46.13	-27.87	74	27.02	40.11	13.14	34.14	100	0	P	V
		15780	44.52	-29.48	74	25.91	37.85	16.57	35.81	100	0	P	V
													V
													V
802.11a CH 60 5300MHz		10600	44.95	-29.05	74	25.77	40.16	13.2	34.18	100	0	P	H
		15900	44.7	-29.3	74	26.33	37.61	16.58	35.82	100	0	P	H
													H
													H
		10600	46.26	-27.74	74	27.08	40.16	13.2	34.18	100	0	P	V
		15900	45.82	-28.18	74	27.45	37.61	16.58	35.82	100	0	P	V
													V
													V
802.11a CH 64 5320MHz		10640	45.67	-28.33	74	26.47	40.18	13.23	34.21	100	0	P	H
		15960	44.47	-29.53	74	26.24	37.47	16.59	35.83	100	0	P	H
													H
													H
		10640	45.45	-28.55	74	26.25	40.18	13.23	34.21	100	0	P	V
		15960	43.65	-30.35	74	25.42	37.47	16.59	35.83	100	0	P	V
													V
													V
Remark	1. No other spurious found. 2. All results are PASS against Peak and Average limit line.												



Band 2 5250~5350MHz

WIFI 802.11n HT20 (Band Edge @ 3m)

WIFI Ant. 1	Note	Frequency (MHz)	Level (dBμV/m)	Over Limit (dB)	Limit Line (dBμV/m)	Read Level (dBμV)	Antenna Factor (dB/m)	Cable Loss (dB)	Preamp Factor (dB)	Ant Pos (cm)	Table Pos (deg)	Peak Avg. (P/A)	Pol. (H/V)
802.11n HT20 CH 52 5260MHz		5108.15	50.91	-23.09	74	43.83	31.69	8.92	33.53	109	271	P	H
		5108	43.09	-10.91	54	36.01	31.69	8.92	33.53	109	271	A	H
	*	5262	105.03	-	-	97.77	31.81	8.99	33.54	109	271	P	H
	*	5262	97.74	-	-	90.48	31.81	8.99	33.54	109	271	A	H
		5412.26	50.92	-23.08	74	43.37	31.93	9.17	33.55	109	271	P	H
		5411.82	42.1	-11.9	54	34.55	31.93	9.17	33.55	109	271	A	H
		5039	49.78	-24.22	74	42.81	31.64	8.86	33.53	111	246	P	V
		5108.3	41.4	-12.6	54	34.32	31.69	8.92	33.53	111	246	A	V
	*	5262	102.19	-	-	94.93	31.81	8.99	33.54	111	246	P	V
	*	5262	94.51	-	-	87.25	31.81	8.99	33.54	111	246	A	V
		5363	51.16	-22.84	74	43.68	31.89	9.13	33.54	111	246	P	V
		5411.6	40.81	-13.19	54	33.26	31.93	9.17	33.55	111	246	A	V
802.11n HT20 CH 60 5300MHz		5134.4	50.89	-23.11	74	43.77	31.71	8.95	33.54	100	272	P	H
		5148	43.36	-10.64	54	36.23	31.72	8.95	33.54	100	272	A	H
	*	5301	104.94	-	-	97.6	31.84	9.04	33.54	100	272	P	H
	*	5301	97.97	-	-	90.63	31.84	9.04	33.54	100	272	A	H
		5353.63	53.86	-20.14	74	46.44	31.88	9.08	33.54	100	272	P	H
		5351.1	45.59	-8.41	54	38.17	31.88	9.08	33.54	100	272	A	H
		5061.65	49.54	-24.46	74	42.53	31.65	8.89	33.53	126	245	P	V
		5147.75	41.66	-12.34	54	34.53	31.72	8.95	33.54	126	245	A	V
	*	5298	102.04	-	-	94.7	31.84	9.04	33.54	126	245	P	V
	*	5298	94.91	-	-	87.57	31.84	9.04	33.54	126	245	A	V
		5356.93	51.13	-22.87	74	43.71	31.88	9.08	33.54	126	245	P	V
		5350.33	43.05	-10.95	54	35.63	31.88	9.08	33.54	126	245	A	V



802.11n HT20 CH 64 5320MHz	*	5318	105.53	-	-	98.18	31.85	9.04	33.54	104	272	P	H
	*	5318	98.04	-	-	90.69	31.85	9.04	33.54	104	272	A	H
		5366.83	54.21	-19.79	74	46.73	31.89	9.13	33.54	104	272	P	H
		5350.77	46.81	-7.19	54	39.39	31.88	9.08	33.54	104	272	A	H
													H
													H
	*	5322	102.39	-	-	95	31.85	9.08	33.54	118	244	P	V
	*	5322	95.01	-	-	87.62	31.85	9.08	33.54	118	244	A	V
		5358.69	53.58	-20.42	74	46.16	31.88	9.08	33.54	118	244	P	V
		5351.98	44.25	-9.75	54	36.83	31.88	9.08	33.54	118	244	A	V
													V
													V
Remark	1. No other spurious found. 2. All results are PASS against Peak and Average limit line.												



Band 2 5250~5350MHz

WIFI 802.11n HT20 (Harmonic @ 3m)

WIFI Ant. 1	Note	Frequency (MHz)	Level (dBμV/m)	Over Limit (dB)	Limit Line (dBμV/m)	Read Level (dBμV)	Antenna Factor (dB/m)	Cable Loss (dB)	Preamp Factor (dB)	Ant Pos (cm)	Table Pos (deg)	Peak Avg. (P/A)	Pol. (H/V)
802.11n HT20 CH 52 5260MHz		10520	47.74	-26.26	74	28.63	40.11	13.14	34.14	100	0	P	H
		15780	47.95	-26.05	74	29.34	37.85	16.57	35.81	100	0	P	H
													H
													H
		10520	46.82	-27.18	74	27.71	40.11	13.14	34.14	100	0	P	V
		15780	45.82	-28.18	74	27.21	37.85	16.57	35.81	100	0	P	V
													V
802.11n HT20 CH 60 5300MHz		10600	48.16	-25.84	74	28.98	40.16	13.2	34.18	100	0	P	H
		15900	46.74	-27.26	74	28.37	37.61	16.58	35.82	100	0	P	H
													H
													H
		10600	48.31	-25.69	74	29.13	40.16	13.2	34.18	100	0	P	V
		15900	45.59	-28.41	74	27.22	37.61	16.58	35.82	100	0	P	V
													V
802.11n HT20 CH 64 5320MHz		10640	48.21	-25.79	74	29.01	40.18	13.23	34.21	100	0	P	H
		15960	45.12	-28.88	74	26.89	37.47	16.59	35.83	100	0	P	H
													H
													H
		10640	47.83	-26.17	74	28.63	40.18	13.23	34.21	100	0	P	V
		15960	44.68	-29.32	74	26.45	37.47	16.59	35.83	100	0	P	V
													V
Remark	1. No other spurious found.												
	2. All results are PASS against Peak and Average limit line.												



Band 2 5250~5350MHz

WIFI 802.11n HT40 (Band Edge @ 3m)

WIFI Ant. 1	Note	Frequency (MHz)	Level (dBμV/m)	Over Limit (dB)	Limit Line (dBμV/m)	Read Level (dBμV)	Antenna Factor (dB/m)	Cable Loss (dB)	Preamp Factor (dB)	Ant Pos (cm)	Table Pos (deg)	Peak Avg. (P/A)	Pol. (H/V)
802.11n HT40 CH 54 5270MHz		5120.75	50.64	-23.36	74	43.57	31.69	8.92	33.54	113	282	P	H
		5121.95	42.78	-11.22	54	35.68	31.69	8.95	33.54	113	282	A	H
	*	5276	102.04	-	-	94.76	31.83	8.99	33.54	113	282	P	H
	*	5276	95.18	-	-	87.9	31.83	8.99	33.54	113	282	A	H
		5350.88	49.65	-24.35	74	42.23	31.88	9.08	33.54	113	282	P	H
		5420.4	42.17	-11.83	54	34.62	31.93	9.17	33.55	113	282	A	H
		5059.7	49.66	-24.34	74	42.65	31.65	8.89	33.53	107	187	P	V
		5122.85	41.01	-12.99	54	33.89	31.71	8.95	33.54	107	187	A	V
	*	5264	97.71	-	-	90.45	31.81	8.99	33.54	107	187	P	V
	*	5264	90.6	-	-	83.34	31.81	8.99	33.54	107	187	A	V
		5350.66	49.57	-24.43	74	42.15	31.88	9.08	33.54	107	187	P	V
		5352.97	40.52	-13.48	54	33.1	31.88	9.08	33.54	107	187	A	V
802.11n HT40 CH 62 5310MHz		5040.8	49.95	-24.05	74	42.98	31.64	8.86	33.53	104	280	P	H
		5132.45	41.42	-12.58	54	34.3	31.71	8.95	33.54	104	280	A	H
	*	5320	100.88	-	-	93.53	31.85	9.04	33.54	104	280	P	H
	*	5320	93.74	-	-	86.39	31.85	9.04	33.54	104	280	A	H
		5352.97	58.45	-15.55	74	51.03	31.88	9.08	33.54	104	280	P	H
		5350.66	50.2	-3.8	54	42.78	31.88	9.08	33.54	104	280	A	H
		5049.05	49.35	-24.65	74	42.35	31.64	8.89	33.53	100	187	P	V
		5137.1	40.69	-13.31	54	33.57	31.71	8.95	33.54	100	187	A	V
	*	5312	96.74	-	-	89.39	31.85	9.04	33.54	100	187	P	V
	*	5312	89.86	-	-	82.51	31.85	9.04	33.54	100	187	A	V
	5351.87	54.45	-19.55	74	47.03	31.88	9.08	33.54	100	187	P	V	
	5350	45.44	-8.56	54	38.02	31.88	9.08	33.54	100	187	A	V	

Remark
 1. No other spurious found.
 2. All results are PASS against Peak and Average limit line.



Band 2 5250~5350MHz

WIFI 802.11n HT40 (Harmonic @ 3m)

WIFI Ant. 1	Note	Frequency (MHz)	Level (dBμV/m)	Over Limit (dB)	Limit Line (dBμV/m)	Read Level (dBμV)	Antenna Factor (dB/m)	Cable Loss (dB)	Preamp Factor (dB)	Ant Pos (cm)	Table Pos (deg)	Peak Avg. (P/A)	Pol. (H/V)
802.11n HT40 CH 54 5270MHz		10540	47.03	-26.97	74	27.92	40.12	13.14	34.15	100	0	P	H
		15810	46.8	-27.2	74	28.26	37.78	16.57	35.81	100	0	P	H
													H
													H
		10540	47.25	-26.75	74	28.14	40.12	13.14	34.15	100	0	P	V
		15810	45.52	-28.48	74	26.98	37.78	16.57	35.81	100	0	P	V
													V
													V
802.11n HT40 CH 62 5310MHz		10620	49.28	-24.72	74	30.1	40.17	13.2	34.19	100	0	P	H
		15930	45.69	-28.31	74	27.39	37.54	16.58	35.82	100	0	P	H
													H
													H
		10620	47.2	-26.8	74	28.02	40.17	13.2	34.19	100	0	P	V
		15930	45.21	-28.79	74	26.91	37.54	16.58	35.82	100	0	P	V
													V
													V
Remark	1. No other spurious found. 2. All results are PASS against Peak and Average limit line.												



Band 3 5470~5725MHz

WIFI 802.11a (Band Edge @ 3m)

WIFI Ant. 1	Note	Frequency (MHz)	Level (dBμV/m)	Over Limit (dB)	Limit Line (dBμV/m)	Read Level (dBμV)	Antenna Factor (dB/m)	Cable Loss (dB)	Preamp Factor (dB)	Ant Pos (cm)	Table Pos (deg)	Peak Avg. (P/A)	Pol. (H/V)	
802.11a CH 100 5500MHz		5447.6	53.64	-20.36	74	46.01	31.96	9.22	33.55	105	269	P	H	
		5467.44	45.63	-8.37	54	37.99	31.97	9.22	33.55	105	269	A	H	
	*	5501	105.05	-	-	97.35	32	9.26	33.56	105	269	P	H	
	*	5501	97.74	-	-	90.04	32	9.26	33.56	105	269	A	H	
													H	
														H
			5468.88	51.19	-22.81	74	43.55	31.97	9.22	33.55	107	268	P	V
			5469	43.58	-10.42	54	35.94	31.97	9.22	33.55	107	268	A	V
	*		5498	102.34	-	-	94.63	32	9.26	33.55	107	268	P	V
	*		5498	95.13	-	-	87.42	32	9.26	33.55	107	268	A	V
														V
														V
802.11a CH 116 5580MHz		5453.68	51.15	-22.85	74	43.52	31.96	9.22	33.55	106	270	P	H	
		5426.96	42.62	-11.38	54	35.07	31.93	9.17	33.55	106	270	A	H	
	*	5582	104.09	-	-	96.24	32.12	9.32	33.59	106	270	P	H	
	*	5582	97.17	-	-	89.32	32.12	9.32	33.59	106	270	A	H	
			5748.84	50.06	-23.94	74	41.93	32.34	9.44	33.65	106	270	P	H
			5732.84	40.48	-13.52	54	32.38	32.31	9.44	33.65	106	270	A	H
			5442.8	48.44	-25.56	74	40.82	31.95	9.22	33.55	118	268	P	V
			5427.44	41.02	-12.98	54	33.47	31.93	9.17	33.55	118	268	A	V
	*		5577	102.08	-	-	94.24	32.1	9.32	33.58	118	268	P	V
	*		5577	95.06	-	-	87.22	32.1	9.32	33.58	118	268	A	V
			5733.48	48.97	-25.03	74	40.87	32.31	9.44	33.65	118	268	P	V
			5731.88	40.39	-13.61	54	32.29	32.31	9.44	33.65	118	268	A	V



802.11a CH 140 5700MHz	*	5698	102.79	-	-	94.76	32.27	9.39	33.63	104	270	P	H
	*	5698	95.2	-	-	87.17	32.27	9.39	33.63	104	270	A	H
		5725.24	52.98	-21.02	74	44.87	32.31	9.44	33.64	104	270	P	H
		5725.96	43.99	-10.01	54	35.88	32.31	9.44	33.64	104	270	A	H
													H
													H
	*	5700	101.4	-	-	93.37	32.27	9.39	33.63	125	266	P	V
	*	5700	94.02	-	-	85.99	32.27	9.39	33.63	125	266	A	V
		5728.84	52.27	-21.73	74	44.16	32.31	9.44	33.64	125	266	P	V
		5725.8	43.66	-10.34	54	35.55	32.31	9.44	33.64	125	266	A	V
													V
													V
Remark	1. No other spurious found. 2. All results are PASS against Peak and Average limit line.												



Band 3 5470~5725MHz

WIFI 802.11a (Harmonic @ 3m)

WIFI Ant. 1	Note	Frequency (MHz)	Level (dBμV/m)	Over Limit (dB)	Limit Line (dBμV/m)	Read Level (dBμV)	Antenna Factor (dB/m)	Cable Loss (dB)	Preamp Factor (dB)	Ant Pos (cm)	Table Pos (deg)	Peak Avg. (P/A)	Pol. (H/V)
802.11a CH 100 5500MHz		11000	47.1	-26.9	74	27.61	40.4	13.48	34.39	100	0	P	H
		16500	46.65	-27.35	74	26.75	39	16.81	35.91	100	0	P	H
													H
													H
		11000	46.34	-27.66	74	26.85	40.4	13.48	34.39	100	0	P	V
		16500	45.49	-28.51	74	25.59	39	16.81	35.91	100	0	P	V
													V
													V
802.11a CH 116 5580MHz		11160	42.42	-31.58	74	23	40.27	13.64	34.49	100	0	P	H
		16740	46.81	-27.19	74	26.03	39.92	16.8	35.94	100	0	P	H
													H
													H
		11160	41.41	-32.59	74	21.99	40.27	13.64	34.49	100	0	P	V
		16740	46.16	-27.84	74	25.38	39.92	16.8	35.94	100	0	P	V
													V
													V
802.11a CH 140 5700MHz		11400	44.99	-29.01	74	25.7	40.08	13.87	34.66	100	0	P	H
		17100	48.68	-25.32	74	26.68	41.12	16.85	35.97	100	0	P	H
													H
													H
		11400	45.08	-28.92	74	25.79	40.08	13.87	34.66	100	0	P	V
		17100	47.76	-26.24	74	25.76	41.12	16.85	35.97	100	0	P	V
													V
													V
Remark	1. No other spurious found. 2. All results are PASS against Peak and Average limit line.												



Band 3 5470~5725MHz

WIFI 802.11n HT20 (Band Edge @ 3m)

WIFI Ant. 1	Note	Frequency (MHz)	Level (dBμV/m)	Over Limit (dB)	Limit Line (dBμV/m)	Read Level (dBμV)	Antenna Factor (dB/m)	Cable Loss (dB)	Preamp Factor (dB)	Ant Pos (cm)	Table Pos (deg)	Peak Avg. (P/A)	Pol. (H/V)	
802.11n HT20 CH 100 5500MHz		5461.36	54.37	-19.63	74	46.74	31.96	9.22	33.55	100	278	P	H	
		5470	45.48	-8.52	54	37.84	31.97	9.22	33.55	100	278	A	H	
	*	5503	104.68	-	-	96.98	32	9.26	33.56	100	278	P	H	
	*	5503	97.54	-	-	89.84	32	9.26	33.56	100	278	A	H	
													H	
														H
			5467.6	52.51	-21.49	74	44.87	31.97	9.22	33.55	108	211	P	V
			5466.48	44.32	-9.68	54	36.68	31.97	9.22	33.55	108	211	A	V
		*	5502	102.02	-	-	94.32	32	9.26	33.56	108	211	P	V
		*	5502	94.56	-	-	86.86	32	9.26	33.56	108	211	A	V
													V	
													V	
802.11n HT20 CH 116 5580MHz		5428.24	50.33	-23.67	74	42.78	31.93	9.17	33.55	100	296	P	H	
		5427.92	42.05	-11.95	54	34.5	31.93	9.17	33.55	100	296	A	H	
	*	5579	103.63	-	-	95.8	32.1	9.32	33.59	100	296	P	H	
	*	5579	96.66	-	-	88.83	32.1	9.32	33.59	100	296	A	H	
			5735	49.27	-24.73	74	41.14	32.34	9.44	33.65	100	296	P	H
			5732.04	40.54	-13.46	54	32.44	32.31	9.44	33.65	100	296	A	H
			5433.2	48.67	-25.33	74	41.1	31.95	9.17	33.55	100	210	P	V
			5428.08	40.56	-13.44	54	33.01	31.93	9.17	33.55	100	210	A	V
		*	5578	99.22	-	-	91.39	32.1	9.32	33.59	100	210	P	V
		*	5578	92.14	-	-	84.31	32.1	9.32	33.59	100	210	A	V
		5745	49.56	-24.44	74	41.43	32.34	9.44	33.65	100	210	P	V	
		5732.44	40.05	-13.95	54	31.95	32.31	9.44	33.65	100	210	A	V	



802.11n HT20 CH 140 5700MHz	*	5699	102.75	-	-	94.72	32.27	9.39	33.63	100	295	P	H
	*	5699	95.79	-	-	87.76	32.27	9.39	33.63	100	295	A	H
		5725.08	54.63	-19.37	74	46.52	32.31	9.44	33.64	100	295	P	H
		5725	47.24	-6.76	54	39.13	32.31	9.44	33.64	100	295	A	H
													H
													H
	*	5705	98.32	-	-	90.28	32.29	9.39	33.64	100	211	P	V
	*	5705	91.51	-	-	83.47	32.29	9.39	33.64	100	211	A	V
		5727.32	51.92	-22.08	74	43.81	32.31	9.44	33.64	100	211	P	V
		5725	44.17	-9.83	54	36.06	32.31	9.44	33.64	100	211	A	V
													V
													V
Remark	1. No other spurious found. 2. All results are PASS against Peak and Average limit line.												



Band 3 5470~5725MHz

WIFI 802.11n HT20 (Harmonic @ 3m)

WIFI Ant. 1	Note	Frequency (MHz)	Level (dBμV/m)	Over Limit (dB)	Limit Line (dBμV/m)	Read Level (dBμV)	Antenna Factor (dB/m)	Cable Loss (dB)	Preamp Factor (dB)	Ant Pos (cm)	Table Pos (deg)	Peak Avg. (P/A)	Pol. (H/V)	
802.11n HT20 CH 100 5500MHz		11000	48.18	-25.82	74	28.69	40.4	13.48	34.39	100	0	P	H	
		16500	49.23	-24.77	74	29.33	39	16.81	35.91	100	0	P	H	
													H	
													H	
			11000	47.63	-26.37	74	28.14	40.4	13.48	34.39	100	0	P	V
			16500	47.47	-26.53	74	27.57	39	16.81	35.91	100	0	P	V
														V
802.11n HT20 CH 116 5580MHz		11160	44.19	-29.81	74	24.77	40.27	13.64	34.49	100	0	P	H	
		16740	48.33	-25.67	74	27.55	39.92	16.8	35.94	100	0	P	H	
													H	
													H	
			11160	42.89	-31.11	74	23.47	40.27	13.64	34.49	100	0	P	V
			16740	48.95	-25.05	74	28.17	39.92	16.8	35.94	100	0	P	V
														V
802.11n HT20 CH 140 5700MHz		11400	47.01	-26.99	74	27.72	40.08	13.87	34.66	100	0	P	H	
		17100	51	-23	74	29	41.12	16.85	35.97	100	0	P	H	
													H	
													H	
			11400	46.96	-27.04	74	27.67	40.08	13.87	34.66	100	0	P	V
			17100	50	-24	74	28	41.12	16.85	35.97	100	0	P	V
														V
Remark	1. No other spurious found.													
	2. All results are PASS against Peak and Average limit line.													



Band 3 5470~5725MHz

WIFI 802.11n HT40 (Band Edge @ 3m)

WIFI Ant. 1	Note	Frequency (MHz)	Level (dBμV/m)	Over Limit (dB)	Limit Line (dBμV/m)	Read Level (dBμV)	Antenna Factor (dB/m)	Cable Loss (dB)	Preamp Factor (dB)	Ant Pos (cm)	Table Pos (deg)	Peak Avg. (P/A)	Pol. (H/V)
802.11n HT40 CH 102 5510MHz		5467.44	59.89	-14.11	74	52.25	31.97	9.22	33.55	100	298	P	H
		5470	50.84	-3.16	54	43.2	31.97	9.22	33.55	100	298	A	H
	*	5513	100.27	-	-	92.57	32	9.26	33.56	100	298	P	H
	*	5513	92.86	-	-	85.16	32	9.26	33.56	100	298	A	H
		5739.32	49.34	-24.66	74	41.21	32.34	9.44	33.65	100	298	P	H
		5763.8	40.21	-13.79	54	32.01	32.36	9.49	33.65	100	298	A	H
		5465.84	54.12	-19.88	74	46.48	31.97	9.22	33.55	109	222	P	V
		5469.68	46.82	-7.18	54	39.18	31.97	9.22	33.55	109	222	A	V
	*	5508	95.99	-	-	88.29	32	9.26	33.56	109	222	P	V
	*	5508	89.34	-	-	81.64	32	9.26	33.56	109	222	A	V
		5737.96	48.93	-25.07	74	40.8	32.34	9.44	33.65	109	222	P	V
		5763.32	40.09	-13.91	54	31.89	32.36	9.49	33.65	109	222	A	V
802.11n HT40 CH 110 5550MHz		5461.84	50.86	-23.14	74	43.23	31.96	9.22	33.55	100	293	P	H
		5469.36	42.03	-11.97	54	34.39	31.97	9.22	33.55	100	293	A	H
	*	5546	98.92	-	-	91.15	32.05	9.29	33.57	100	293	P	H
	*	5546	92.32	-	-	84.55	32.05	9.29	33.57	100	293	A	H
		5751.56	49.01	-24.99	74	40.86	32.36	9.44	33.65	100	293	P	H
		5747.24	40.17	-13.83	54	32.04	32.34	9.44	33.65	100	293	A	H
		5408.24	49.21	-24.79	74	41.67	31.92	9.17	33.55	100	223	P	V
		5467.12	41.19	-12.81	54	33.55	31.97	9.22	33.55	100	223	A	V
	*	5542	96.49	-	-	88.72	32.05	9.29	33.57	100	223	P	V
	*	5542	89.69	-	-	81.92	32.05	9.29	33.57	100	223	A	V
		5735.32	49.36	-24.64	74	41.23	32.34	9.44	33.65	100	223	P	V
		5729.4	40.27	-13.73	54	32.16	32.31	9.44	33.64	100	223	A	V



802.11n HT40 CH 134 5670MHz		5468.4	48.56	-25.44	74	40.92	31.97	9.22	33.55	100	291	P	H
		5467.6	40.39	-13.61	54	32.75	31.97	9.22	33.55	100	291	A	H
	*	5667	100.6	-	-	92.63	32.24	9.35	33.62	100	291	P	H
	*	5667	92.75	-	-	84.78	32.24	9.35	33.62	100	291	A	H
		5731.64	52.35	-21.65	74	44.25	32.31	9.44	33.65	100	291	P	H
		5725.96	41.94	-12.06	54	33.83	32.31	9.44	33.64	100	291	A	H
		5423.44	48.57	-25.43	74	41.02	31.93	9.17	33.55	100	225	P	V
		5445.2	40.39	-13.61	54	32.77	31.95	9.22	33.55	100	225	A	V
	*	5670	97.04	-	-	89.07	32.22	9.35	33.61	100	225	P	V
	*	5670	89.19	-	-	81.22	32.24	9.35	33.62	100	225	A	V
		5725.88	53.05	-20.95	74	44.94	32.31	9.44	33.64	100	225	P	V
		5726.84	41.61	-12.39	54	33.5	32.31	9.44	33.64	100	225	A	V
Remark	1. No other spurious found. 2. All results are PASS against Peak and Average limit line.												



Band 3 5470~5725MHz

WIFI 802.11n HT40 (Harmonic @ 3m)

WIFI Ant. 1	Note	Frequency (MHz)	Level (dBμV/m)	Over Limit (dB)	Limit Line (dBμV/m)	Read Level (dBμV)	Antenna Factor (dB/m)	Cable Loss (dB)	Preamp Factor (dB)	Ant Pos (cm)	Table Pos (deg)	Peak Avg. (P/A)	Pol. (H/V)	
802.11n HT40 CH 102 5510MHz		11020	47.85	-26.15	74	28.39	40.39	13.48	34.41	100	0	P	H	
		16530	48.65	-25.35	74	28.62	39.13	16.81	35.91	100	0	P	H	
													H	
													H	
			11020	47.01	-26.99	74	27.55	40.39	13.48	34.41	100	0	P	V
			16530	47.28	-26.72	74	27.25	39.13	16.81	35.91	100	0	P	V
														V
802.11n HT40 CH 110 5550MHz		11100	47.91	-26.09	74	28.49	40.32	13.56	34.46	100	0	P	H	
		16650	48.17	-25.83	74	27.71	39.59	16.8	35.93	100	0	P	H	
													H	
													H	
			11100	49.3	-24.7	74	29.88	40.32	13.56	34.46	100	0	P	V
			16650	49.42	-24.58	74	28.96	39.59	16.8	35.93	100	0	P	V
														V
802.11n HT40 CH 134 5670MHz		11340	46.9	-27.1	74	27.59	40.13	13.79	34.61	100	0	P	H	
		17010	49.58	-24.42	74	27.81	40.94	16.8	35.97	100	0	P	H	
													H	
													H	
			11340	46.65	-27.35	74	27.34	40.13	13.79	34.61	100	0	P	V
			17010	49.41	-24.59	74	27.64	40.94	16.8	35.97	100	0	P	V
														V
Remark	1. No other spurious found.													
	2. All results are PASS against Peak and Average limit line.													



Emission below 1GHz

WIFI 802.11a (LF @ 3m)

WIFI Ant. 1	Note	Frequency (MHz)	Level (dBμV/m)	Over Limit (dB)	Limit Line (dBμV/m)	Read Level (dBμV)	Antenna Factor (dB/m)	Cable Loss (dB)	Preamp Factor (dB)	Ant Pos (cm)	Table Pos (deg)	Peak Avg. (P/A)	Pol. (H/V)	
802.11a LF		85.35	18.42	-21.58	40	41.26	7.67	1.28	31.79	247	8	P	H	
		176.07	13.72	-29.78	43.5	35.38	8.48	1.64	31.78	-	-	P	H	
		261.39	15.21	-30.79	46	32.1	12.94	1.94	31.77	-	-	P	H	
		421.8	22.31	-23.69	46	35.06	16.66	2.41	31.82	-	-	P	H	
		709.5	22.87	-23.13	46	32.67	19.09	3.14	32.03	-	-	P	H	
		923.7	24.32	-21.68	46	31.81	20.2	3.55	31.24	-	-	P	H	
														H
														H
														H
														H
														H
														H
			69.42	10.7	-29.3	40	36.31	5.14	1.04	31.79	-	-	P	V
			173.91	18.43	-25.07	43.5	40	8.57	1.64	31.78	-	-	P	V
			281.91	15.26	-30.74	46	32.54	12.54	1.94	31.76	-	-	P	V
			386.1	18.71	-27.29	46	33.1	15.08	2.32	31.79	-	-	P	V
			701.8	22.25	-23.75	46	32.21	18.94	3.14	32.04	-	-	P	V
			906.9	22.95	-23.05	46	30.67	20.1	3.55	31.37	118	328	P	V
													V	
													V	
													V	
													V	
													V	
													V	
Remark	1. No other spurious found. 2. All results are PASS against limit line.													



Emission below 1GHz

WIFI 802.11n HT20 (LF @ 3m)

WIFI	Note	Frequency	Level	Over	Limit	Read	Antenna	Cable	Preamp	Ant	Table	Peak	Pol.	
Ant.				Limit	Line	Level	Factor	Loss	Factor	Pos	Pos	Avg.		
1		(MHz)	(dBμV/m)	(dB)	(dBμV/m)	(dBμV)	(dB/m)	(dB)	(dB)	(cm)	(deg)	(P/A)	(H/V)	
802.11n HT20 LF		53.76	23.22	-16.78	40	47.6	6.38	1.04	31.8	-	-	P	H	
		169.59	15.92	-27.58	43.5	37.24	8.82	1.64	31.78	-	-	P	H	
		287.85	13.63	-32.37	46	30.62	12.66	2.11	31.76	-	-	P	H	
		307.7	20.56	-25.44	46	36.9	13.31	2.11	31.76	-	-	P	H	
		626.9	31.34	-14.66	46	41.42	19	2.96	32.04	218	12	P	H	
		967.1	22.9	-31.1	54	29.55	20.47	3.78	30.9	-	-	P	H	
														H
														H
														H
														H
														H
														H
														H
			49.44	29.94	-10.06	40	52.8	7.9	1.04	31.8	277	198	P	V
			173.91	18.43	-25.07	43.5	40	8.57	1.64	31.78	-	-	P	V
			281.91	15.26	-30.74	46	32.54	12.54	1.94	31.76	-	-	P	V
			357.4	14.85	-31.15	46	29.89	14.57	2.17	31.78	-	-	P	V
			629.7	18.4	-27.6	46	28.48	19	2.96	32.04	-	-	P	V
			928.6	21.21	-24.79	46	28.53	20.2	3.68	31.2	-	-	P	V
														V
													V	
													V	
													V	
													V	
													V	
Remark	1. No other spurious found. 2. All results are PASS against limit line.													



Emission below 1GHz

WIFI 802.11n HT40 (LF @ 3m)

WIFI	Note	Frequency	Level	Over	Limit	Read	Antenna	Cable	Preamp	Ant	Table	Peak	Pol.	
Ant.				Limit	Line	Level	Factor	Loss	Factor	Pos	Pos	Avg.		
1		(MHz)	(dBμV/m)	(dB)	(dBμV/m)	(dBμV)	(dB/m)	(dB)	(dB)	(cm)	(deg)	(P/A)	(H/V)	
802.11n HT40 LF		78.6	20.36	-19.64	40	44.72	6.39	1.04	31.79	-	-	P	H	
		169.59	15.92	-27.58	43.5	37.24	8.82	1.64	31.78	-	-	P	H	
		261.39	15.21	-30.79	46	32.1	12.94	1.94	31.77	-	-	P	H	
		421.8	22.31	-23.69	46	35.06	16.66	2.41	31.82	-	-	P	H	
		636	29.4	-16.6	46	39.42	19.06	2.96	32.04	100	29	P	H	
		895.7	23.79	-22.21	46	31.59	20.1	3.55	31.45	-	-	P	H	
														H
														H
														H
														H
														H
														H
														H
			52.41	26.32	-13.68	40	50.22	6.86	1.04	31.8	229	83	P	V
			181.47	20.42	-23.08	43.5	42.25	8.31	1.64	31.78	-	-	P	V
			251.4	21.88	-24.12	46	39.57	12.14	1.94	31.77	-	-	P	V
			331.5	23.43	-22.57	46	39.4	13.63	2.17	31.77	-	-	P	V
			566.7	27.74	-18.26	46	38.34	18.5	2.89	31.99	-	-	P	V
			846.7	22.99	-23.01	46	31.04	20.2	3.44	31.69	-	-	P	V
														V
													V	
													V	
													V	
													V	
													V	
Remark	1. No other spurious found. 2. All results are PASS against limit line.													



Note symbol

*	Fundamental Frequency which can be ignored. However, the level of any unwanted emissions shall not exceed the level of the fundamental frequency.
!	Test result is over limit line.
P/A	Peak or Average
H/V	Horizontal or Vertical



A calculation example for radiated spurious emission is shown as below:

WIFI	Note	Frequency	Level	Over	Limit	Read	Antenna	Cable	Preamp	Ant	Table	Peak	Pol.
Ant.				Limit	Line	Level	Factor	Loss	Factor	Pos	Pos	Avg.	
1		(MHz)	(dBμV/m)	(dB)	(dBμV/m)	(dBμV)	(dB/m)	(dB)	(dB)	(cm)	(deg)	(P/A)	(H/V)
802.11b		2390	55.45	-18.55	74	54.51	32.22	4.58	35.86	103	308	P	H
CH 01													
2412MHz		2390	43.54	-10.46	54	42.6	32.22	4.58	35.86	103	308	A	H

- Level(dBμV/m) =
Antenna Factor(dB/m) + Cable Loss(dB) + Read Level(dBμV) - Preamp Factor(dB)
- Over Limit(dB) = Level(dBμV/m) – Limit Line(dBμV/m)

For Peak Limit @ 2390MHz:

- Level(dBμV/m)
= Antenna Factor(dB/m) + Cable Loss(dB) + Read Level(dBμV) - Preamp Factor(dB)
= 32.22(dB/m) + 4.58(dB) + 54.51(dBμV) – 35.86 (dB)
= 55.45 (dBμV/m)
- Over Limit(dB)
= Level(dBμV/m) – Limit Line(dBμV/m)
= 55.45(dBμV/m) – 74(dBμV/m)
= -18.55(dB)

For Average Limit @ 2390MHz:

- Level(dBμV/m)
= Antenna Factor(dB/m) + Cable Loss(dB) + Read Level(dBμV) - Preamp Factor(dB)
= 32.22(dB/m) + 4.58(dB) + 42.6(dBμV) – 35.86 (dB)
= 43.54 (dBμV/m)
- Over Limit(dB)
= Level(dBμV/m) – Limit Line(dBμV/m)
= 43.54(dBμV/m) – 54(dBμV/m)
= -10.46(dB)

Both peak and average measured complies with the limit line, so test result is “PASS”.