

HAC_E_Dipole_835_150819

DUT: HAC-Dipole 835 MHz

Communication System: CW; Frequency: 835 MHz; Duty Cycle: 1:1
 Medium: Air Medium parameters used: $\sigma = 0$ S/m, $\epsilon_r = 1$; $\rho = 0$ kg/m³
 Ambient Temperature : 23.2 °C

DASY5 Configuration

- Probe: ER3DV6 - SN2358; ConvF(1, 1, 1); Calibrated: 2015/1/26;
- Sensor-Surface: (Fix Surface)
- Electronics: DAE4 Sn1279; Calibrated: 2015/7/21
- Phantom: HAC Test Arch with AMCC; Type: SD HAC P01 BA;
- Measurement SW: DASY52, Version 52.8 (8); SEMCAD X Version 14.6.10 (7331)

E Scan - measurement distance from the probe sensor center to CD835 = 10mm & 15mm/Hearing Aid Compatibility Test at 15mm distance (41x361x1): Interpolated grid:

dx=0.5000 mm, dy=0.5000 mm
 Device Reference Point: 0, 0, -6.3 mm
 Reference Value = 114.7 V/m; Power Drift = 0.02 dB
 PMR not calibrated. PMF = 1.000 is applied.
 E-field emissions = 108.9 V/m
 Average value of Total=(108.9+99.65) / 2 = 104.275 V/m

PMF scaled E-field

Grid 1 M4 106.6 V/m	Grid 2 M4 108.9 V/m	Grid 3 M4 106.5 V/m
Grid 4 M4 57.71 V/m	Grid 5 M4 59.44 V/m	Grid 6 M4 58.75 V/m
Grid 7 M4 97.23 V/m	Grid 8 M4 99.65 V/m	Grid 9 M4 98.16 V/m

Cursor:

Total = 108.9 V/m
 E Category: M4
 Location: 0, -77.5, 9.7 mm

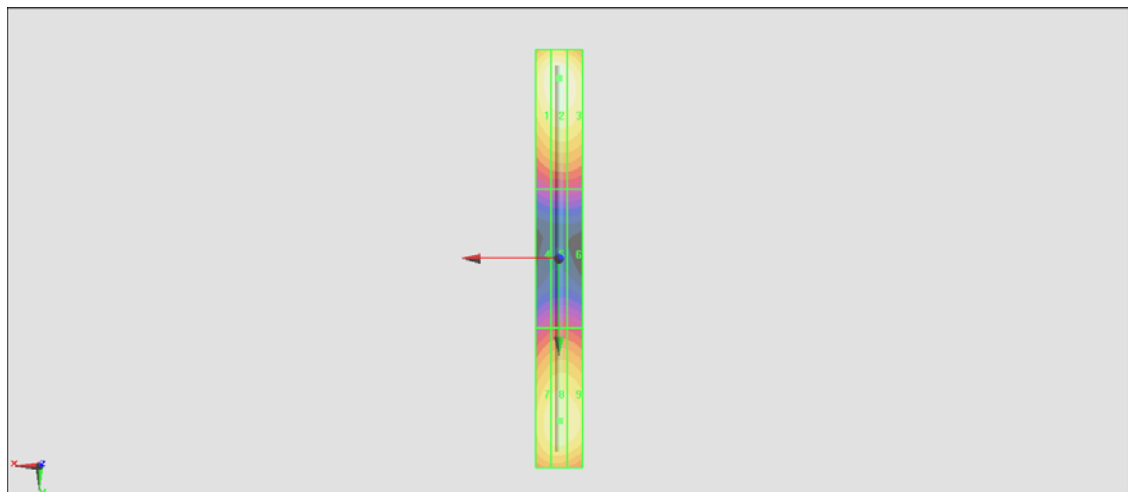
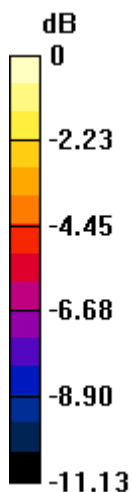

0 dB = 108.9 V/m = 40.74 dBV/m

HAC_E_Dipole_1880_150819

DUT: HAC Dipole 1880 MHz

Communication System: CW; Frequency: 1880 MHz; Duty Cycle: 1:1
 Medium: Air Medium parameters used: $\sigma = 0$ S/m, $\epsilon_r = 1$; $\rho = 0$ kg/m³
 Ambient Temperature : 23.2 °C

DASY5 Configuration

- Probe: ER3DV6 - SN2358; ConvF(1, 1, 1); Calibrated: 2015/1/26;
- Sensor-Surface: (Fix Surface)
- Electronics: DAE4 Sn1279; Calibrated: 2015/7/21
- Phantom: HAC Test Arch with AMCC; Type: SD HAC P01 BA;
- Measurement SW: DASY52, Version 52.8 (8); SEMCAD X Version 14.6.10 (7331)

E Scan - measurement distance from the probe sensor center to CD1880 = 10mm & 15mm/Hearing Aid Compatibility Test at 15mm distance (41x181x1): Interpolated grid:
 dx=0.5000 mm, dy=0.5000 mm
 Device Reference Point: 0, 0, -6.3 mm
 Reference Value = 137.1 V/m; Power Drift = 0.00 dB
 PMR not calibrated. PMF = 1.000 is applied.
 E-field emissions = 89.16 V/m
 Average value of Total=(86.58+89.16) / 2 = 87.87 V/m

PMF scaled E-field

Grid 1 M3 85.24 V/m	Grid 2 M3 86.58 V/m	Grid 3 M3 85.21 V/m
Grid 4 M3 67.36 V/m	Grid 5 M3 68.85 V/m	Grid 6 M3 68.06 V/m
Grid 7 M3 87.22 V/m	Grid 8 M3 89.16 V/m	Grid 9 M3 87.72 V/m

Cursor:

Total = 89.16 V/m

E Category: M3

Location: 0, 31, 9.7 mm

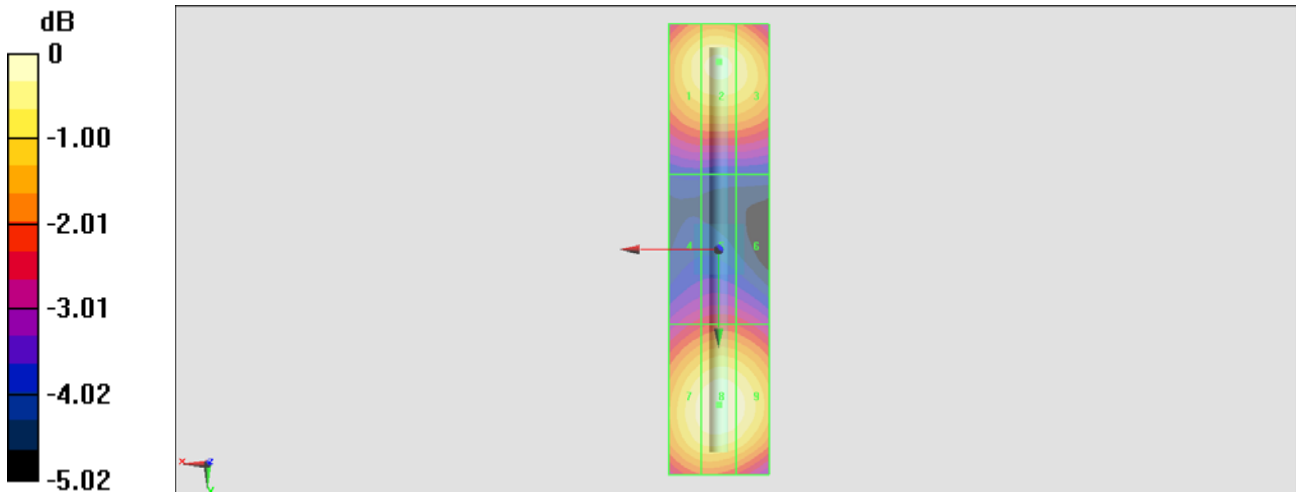

0 dB = 89.16 V/m = 39.00 dBV/m