

EMI TEST REPORT**CONFIDENTIAL**

Project No. : JB-Z0074

Manufacture : Sony Mobile Communications Inc.

Address : W Building 1-8-15 Konan, Minato-Ku, Tokyo 108-0075 JAPAN

Type of Equipment : GSM/ WCDMA/LTE Phone + Bluetooth, DTS/UNII a/b/g/n/ac, ANT+ & NFC

FCC ID : PY7-PM0881

Serial No. : CB5A278ZYN

Regulation Applied : 47 CFR Part 15 Subpart B, Class B

Final Judgment : Passed

Sample Receipt : July 21, 2015

Testing : July 21 - 30, 2015

Reported : August 05, 2015

Reported by :

Approved by :



Akari Ohyama
 Test Engineer
 EMC/ RF Test Laboratory Main Lab.
 Design Technology Division
 Sony EMCS Corporation



Teruki Kurihara
 Technical Manager
 EMC/ RF Test Laboratory Main Lab.
 Design Technology Division
 Sony EMCS Corporation

- Notice*
- * *These test results relate only to the items (combination equipment, test configuration, operation condition etc.) tested.*
 - * *This report shall not be reproduced except in full, without written approval of the laboratory.*
 - * *This report must not be used by the client to claim product endorsement by A2LA or any agency of the U.S. Government.*
 - * *Hereby certify that no party is subject to a denial of federal benefits pursuant to section 5301 of the Anti-Drug Abuse Act.*
 - * *All test results are traceable to the national and / or international standards.*



TESTING CERT #3203.01

TABLE OF CONTENTS

- 1. General Information 3
 - 1.1. Description of Equipment Under Test (EUT) 3
 - 1.2. Summary of Test Result 3
 - 1.3. Tested Methodology 3
 - 1.4. Test Facility 7
- 2. System Test Configuration 8
 - 2.1. Validation..... 8
 - 2.2. Operating Condition..... 8
 - 2.3. Special Accessories..... 8
 - 2.4. EUT Modifications..... 8
 - 2.5. Configuration of Tested System..... 9
- 3. Conducted Emissions Data..... 11
- 4. Radiated Emissions Data..... 13
- 5. Method of Calculation..... 24
 - 5.1. Conducted Emissions Measurement..... 24
 - 5.2. Radiated Emissions Measurement 24
- 6. List of Test Equipment 25
- 7. Conducted Emissions Measurement Photo(s)..... 26
- 8. Radiated Emissions Measurement Photo(s) 27

Note

- indicates that the listed condition, standard or equipment is applicable for this report.
- indicates that the listed condition, standard or equipment is not applicable for this report.

CE (Conducted Emissions)

TEST PROCEDURE

ANSI C63.4: 2009

Limit

§15.107 (a) Except for Class A digital devices, the equipment that is designed to be connected to the public utility (AC) power line, the radio frequency voltage that is conducted back onto the AC power line on any frequency or frequencies within the band 150 kHz to 30 MHz shall not exceed the limits in the following table, as measured using a 50 μ H/50 ohms line impedance stabilization network (LISN). Compliance with the provisions of this paragraph shall be based on the measurement of the radio frequency voltage between each power line and ground at the power terminal. The lower limit applies at the band edges.

Frequency range (MHz)	Limits (dB μ V)	
	Quasi-peak limits	Average
0.15 to 0.50	66 to 56	66 to 46
0.50 to 5	56	46
5 to 30	60	50

Note:

1. The lower limit shall apply at the transition frequencies
2. The limit decreases linearly with the logarithm of the frequency in the range 0.15 MHz to 0.50 MHz.

RE (Radiated Emissions)

TEST PROCEDURE

ANSI C63.4: 2009

The highest clock frequency generated or used in the EUT is 1.0 GHz therefore the frequency range was investigated from 30 MHz to 18 GHz.

Limit

§15.109 (a) Except for Class A digital devices, the field strength of radiated emissions from unintentional radiators at a distance of 3 meters shall not exceed the following values:

Frequency range (MHz)	Quasi-peak limits (dB μ V/m)
30 to 88	40
88 to 216	43.5
216 to 960	46
Above 960 MHz	54

Note: The lower limit shall apply at the transition frequency.

CE (Conducted Emissions)

1. The rear of the top of the non-conductive table (EUT table) made of (FRP, wood, styrene foam, other non-conductive material) was placed 0.4 m from the vertical ground reference plane on the one of the walls of the shielded room.
2. The dimensions of the EUT table were 0.8 m high, 1.5 m long and 1.0 m wide.
3. The connection of the EUT to the line impedance stabilization network (LISN) was performed.
4. The LISN was placed in 80 cm from the nearest part of the EUT chassis.
5. The excess length of the AC cable between the EUT and the LISN receptacle shall be folded back and forth at the center of the lead to form a bundle not exceeding 40 cm in length.
6. The connection of the all other equipment to the second LISN was performed. The second LISN was terminated with a 50-ohm terminator.
7. Interconnecting cables that hang closer than 40 cm to the horizontal ground reference plane shall be folded back and forth forming a bundle 30 to 40 cm long, hanging approximately in the middle between the horizontal ground reference plane and the EUT table.
8. Find the worst mode and set-up of the EUT according to the following measurement.
How to find the worst operation mode:
Connect all peripherals and check all operation modes of the EUT.
The worst point can be observed with the spectrum analyzer (peak detector mode, RBW: 10 kHz).
How to find the worst set-up:
Connect all peripherals and exchange the position of peripherals and cables.
The worst point can be observed with the spectrum analyzer (peak detector mode, RBW: 10 kHz)
9. With the condition mentioned in the above 8, the measurement in peak detector mode was carried out with the spectrum analyzer.
10. Choose the 6 worst points on the data of the spectrum analyzer.
11. Then, the measurements in quasi-peak detector mode (RBW: 9 kHz) and average detector mode (RBW: 9 kHz) on those points were carried out with the EMI test receiver.
12. The measurement has been conducted with both line and neutral power supply polarization.

RE (Radiated Emissions)

1. The center of the top of the non-conductive table (EUT table) made of (FRP, wood, styrene foam, other non-conductive material) was placed in the center of the turntable.
2. The dimensions of the EUT table were 0.8 m high, 1.5 m long and 1.0 m wide.
3. For measurement frequency above 1000 MHz, a minimum area of 3.0 m by 3.0 m of the ground plane shall be covered by RF absorbing material. (see Figure 1)

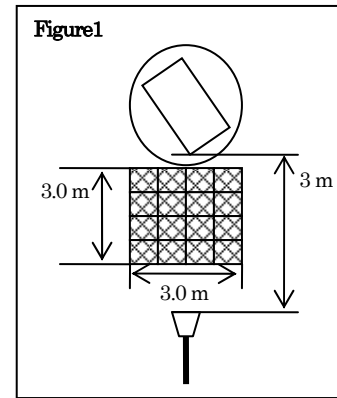

4. Find the worst operation mode and set-up of the EUT according to the following measurement.

How to find the worst operation mode:
Connect all peripherals and check all operation modes of the EUT while rotating the turntable and moving the antenna up and down.
The worst point can be observed with the spectrum analyzer (peak detector mode, 3 dB RBW: 100 kHz).

How to find the worst set-up:
Connect all peripherals and exchange the position of peripherals and cables while rotating the turntable and moving the antenna up and down.
The worst point can be observed with the spectrum analyzer (peak detector mode, 3 dB RBW: 100 kHz).
5. With the condition mentioned in the above 4, the antenna and the turntable must be actuated with the following range, the measurement in peak detector mode was carried out with the spectrum analyzer.

Antenna	: Biconical Antenna & Logperiodic Antenna
Antenna scanning range	: 1 - 4 m, Horizontal and Vertical
Rotating angle of turntable	: 360 degrees

For measurement frequency above 1000 MHz, place the measurement antenna so that the EUT system is covered within 3dB beam width of the measurement antenna at the specified measurement distance. When the beam widths of the measurement antenna are smaller than the width of the EUT system, move the measurement antenna to the left and right. The measurement distance shall be more than the Rayleigh distance.
The measurement antenna aimed at the source of emission to get the maximum emission, and the final measurement is performed at the angle where the maximum emission is observed.
6. Choose the 6 worst points on the data of the spectrum analyzer.
7. Among the points chosen in the above 6, the EUT's maximum emissions were observed with the following method.
First, set the antenna height to 1 m and rotate the turntable until the maximum emission was observed. Then, move the antenna up and down to observe the maximum emission without rotating the turntable. Again with that position, rotate the turntable to find the worst point without moving the antenna. For measurement frequency above 1000 MHz, use the same antenna position as the preliminary testing to the final test.
8. Then measurement frequency below 1000 MHz, the measurement in quasi-peak detector mode (6 dB RBW: 120 kHz) on that worst points were carried out with the EMI test receiver.
Then measurement frequency above 1000 MHz, the measurement in peak detector mode (3 dB RBW: 1 MHz) and average detector mode (3 dB RBW: 1 MHz) on that worst points were carried out with the spectrum analyzer.

1.4. Test Facility

Address of Test Facility

Test Facility Name : Sony EMCS EMC/ RF Test Laboratory Main Lab.
Address : Kisarazu Site 8-4 Shiomi Kisarazu-shi, Chiba, 292-0834 Japan
Phone : +81 438 37 2750

Conducted Emissions

Shielded Room
 EMC Site 4th Site

Radiated Emissions

Semi-Anechoic chamber
 EMC Site 4th Site

A2LA Accreditation for Test Facility

The above test facility has been fully reported to A2LA and accepted as follows:

Effective dates: 2013-09-30 through 2015-10-31

FCC Registration for Test Facility

Designation Number : JP4005
Test Firm Registration Number : 633008

2. System Test Configuration

2.1. Validation

The system was configured for testing in a typical (as a customer would normally use it).
The tests were conducted with the worst case modes as follows.

2.2. Operating Condition

Power Supply Voltage: AC 120 V, 60 Hz

PC Communication mode
- Copy files from EUT to PC.

MHL mode
- Copy files from EUT to 4KTV.

2.3. Special Accessories

Special accessories needed for connecting the EUT to achieve compliance:

None _____

Note :

2.4. EUT Modifications

- No equipment modification to achieve compliance to Class B levels was done during the tests.
- Equipment was modified to achieve compliance to Class B level as below.

Responsible Party Signature

Typed/ Print Name :
Responsible Party :
Position :
Date :

2.5. Configuration of Tested System

The equipment under test (EUT) consists of :

Symbol	Item	Manufacturer	FCC ID	Serial No.
A	EUT	SONY Mobile Communications	PY7-PM0881	CB5A278ZYN

The measurement was carried out with the following support equipment connected :

Symbol	Item	Manufacturer	Model No.	FCC ID	Serial No.
B	Desktop PC	DELL	D13M	DoC	5VLN522
C	USB Mouse	DELL	MS111L	DoC	-
D	USB Keyboard	DELL	KB212-B	DoC	-
E	Monitor	Samsung	204B	DoC	BR20HVRP500521H
F	Headphones	SONY	MDR-NC31E	DoC	-
G	10M/100M HUB	BUFFALO	LSW-TX-5NP	N/A	16481504774092
H	TV	SONY	XBR-49X850B	DoC	5402606

DoC : Device for Declaration of Conformity

Type of Cable

Symbol	Description	Identification (Manufacturer etc.)	Shielded YES / NO	Ferrite Core	Bundled	Length (m)
1	Headphone Cable (for F)	-	YES	NO	-	1.5
2	USB Cable (A-microB)	-	YES	NO	-	1
3	USB Cable (for C)	-	YES	NO	-	1.8
4	USB Cable (for D)	-	YES	YES	-	2
5	AC Cable (for B)	-	NO	NO	Bundled#	1.8
6	Ether Cable	-	NO	NO	-	1
7	AC Cable (for G)	-	NO	NO	-	1.8
8	D-Sub Cable	-	YES	YES	Bundled	2
9	MHL Cable	SONY	YES	NO	Bundled	3
10	AC Cable (for H)	-	NO	NO	-	1.5
11	AC Cable (for E)	-	NO	NO	-	2

Note

Conducted Emission measurement only.

Interconnecting Cables

Cables that hang closer than 40 cm to the ground plane is folded back and forth forming a bundle 30 to 40 cm long, hanging approximately in the middle between the ground plane and the EUT table, shown "Bundled" in the above table.

System configuration

* : EUT  : Ferrite core (Fixed)

PC Communication mode

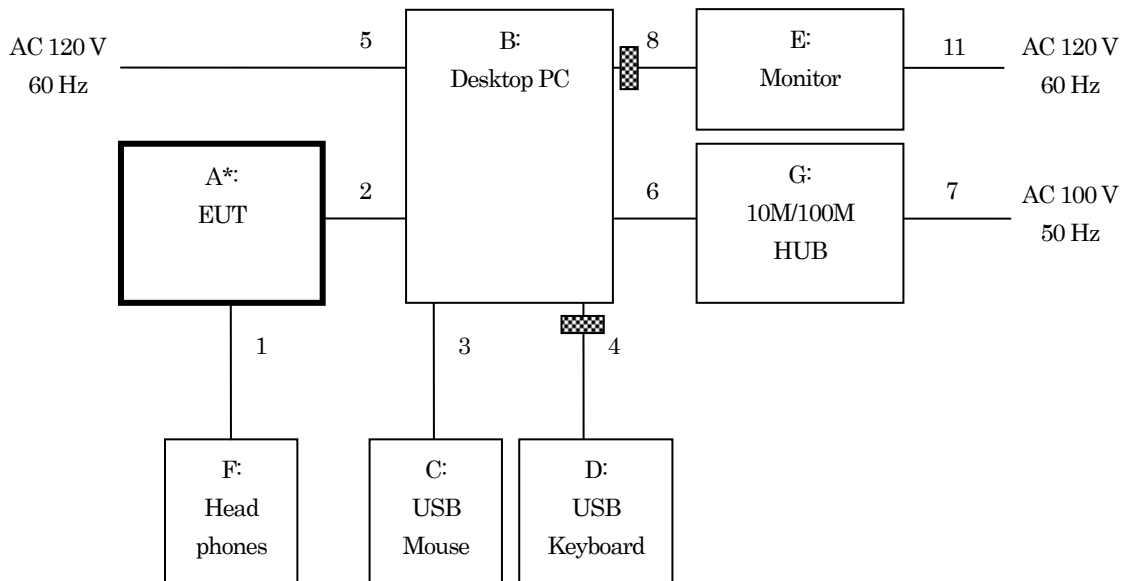

MHL mode

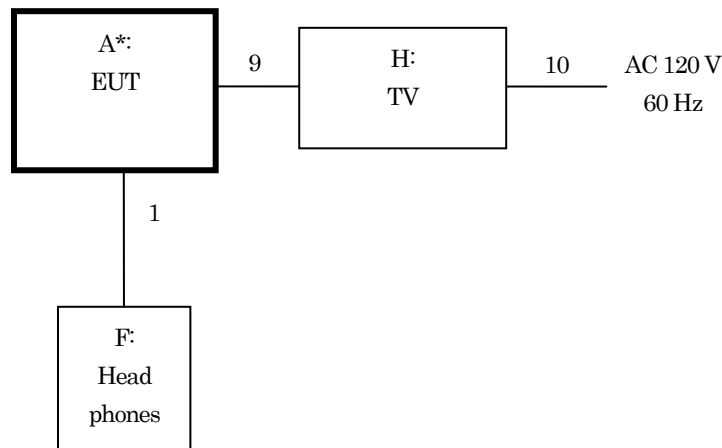

Interconnecting Cables

Cables that hang closer than 40 cm to the ground plane is folded back and forth forming a bundle 30 to 40 cm long, hanging approximately in the middle between the ground plane and the EUT table.

Cables of hand-operated devices, such as keyboards, mice, etc., shall be placed as for normal use.

PC Communication mode

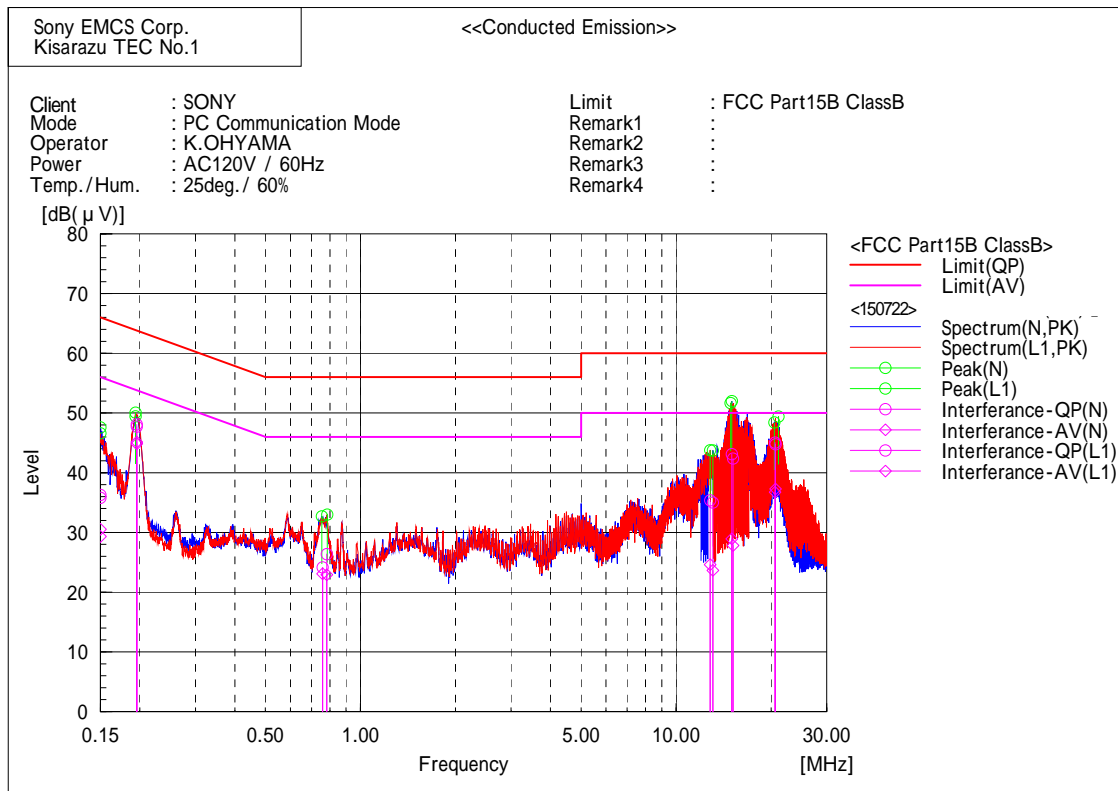

Final Result

--- N Phase ---

No.	Frequency [MHz]	Reading QP [dB(μV)]	Reading AV [dB(μV)]	c.f [dB]	Result QP [dB(μV)]	Result AV [dB(μV)]	Limit QP [dB(μV)]	Limit AV [dB(μV)]	Margin QP [dB]	Margin AV [dB]
1	0.150	19.9	13.4	15.9	35.8	29.3	66.0	56.0	30.2	26.7
2	0.195	31.6	28.8	16.1	47.7	44.9	63.8	53.8	16.1	8.9
3	0.759	8.1	7.1	16.0	24.1	23.1	56.0	46.0	31.9	22.9
4	13.090	18.8	7.5	16.2	35.0	23.7	60.0	50.0	25.0	26.3
5	15.010	26.8	12.6	16.3	43.1	28.9	60.0	50.0	16.9	21.1
6	20.648	28.4	20.9	16.4	44.8	37.3	60.0	50.0	15.2	12.7

--- L1 Phase ---

No.	Frequency [MHz]	Reading QP [dB(μV)]	Reading AV [dB(μV)]	c.f [dB]	Result QP [dB(μV)]	Result AV [dB(μV)]	Limit QP [dB(μV)]	Limit AV [dB(μV)]	Margin QP [dB]	Margin AV [dB]
1	0.150	20.4	14.6	15.9	36.3	30.5	66.0	56.0	29.7	25.5
2	0.196	32.0	29.0	16.1	48.1	45.1	63.8	53.8	15.7	8.7
3	0.782	10.3	6.9	16.0	26.3	22.9	56.0	46.0	29.7	23.1
4	12.830	19.2	8.4	16.2	35.4	24.6	60.0	50.0	24.6	25.4
5	15.140	26.2	11.6	16.2	42.4	27.8	60.0	50.0	17.6	22.2
6	20.580	28.8	20.4	16.3	45.1	36.7	60.0	50.0	14.9	13.3

4. Radiated Emissions Data

The following data lists the significant emissions frequencies measured levels, correction factor (includes cable and Antenna corrections), the corrected reading, the limit, plus margin. Explanation of the correction factor is given in Section 5.

Notes : C.F. : Correction Factor
 PK : Peak detector mode (below 1GHz RBW: 100 kHz, above 1GHz RBW: 1 MHz)
 of the spectrum analyzer
 QP : Quasi-Peak detector mode (RBW: 120 kHz) of the EMI test receiver
 AV : Average detector mode (RBW: 1 MHz) of the spectrum analyzer

* Although "Height" in radiated emissions data, which shows the height of the boom of the antenna mast, might exceed 400.0 cm because of the antenna tilt positioner attached to the edge of the boom for the bore-sighting measurement, the height of the reference point of the antenna does not exceed 400.0 cm.

Test Engineer:

Koji Ohyama

Typed/ Print Name : Koji Ohyama

Date : July 21 - 30, 2015

Below 1 GHz
PC Communication mode

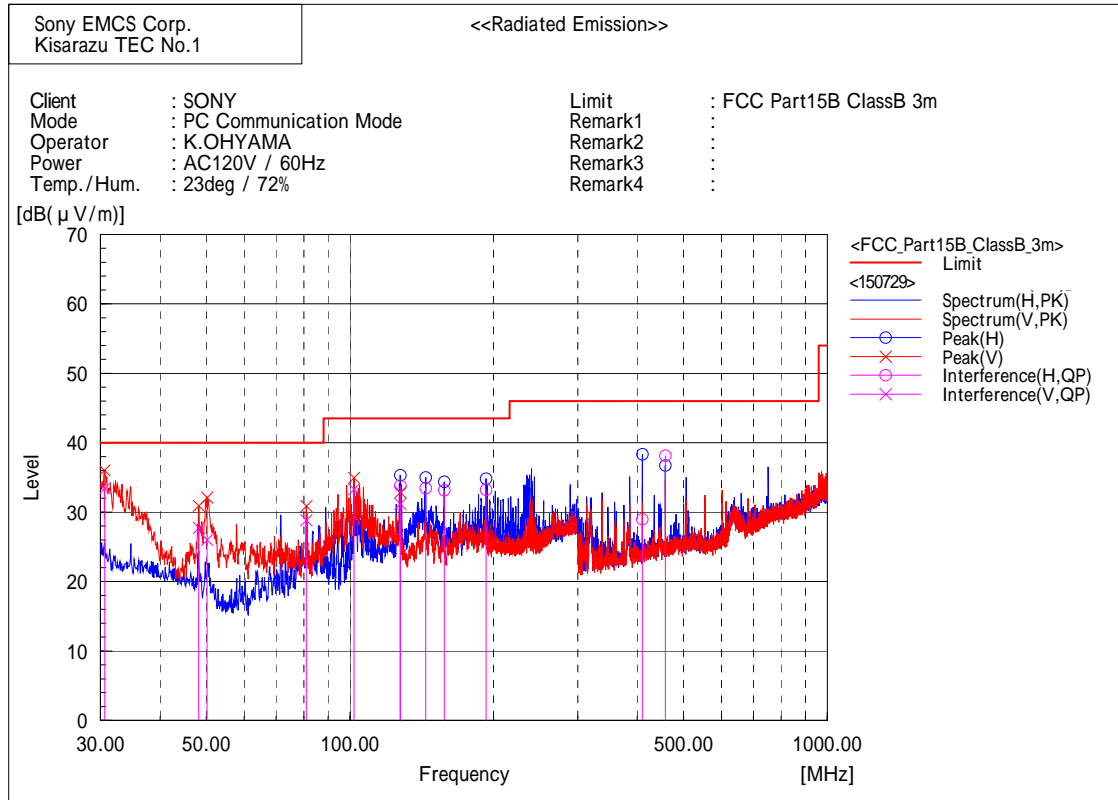

Final Result

--- Horizontal Polarization (QP)---

No.	Frequency [MHz]	Reading [dB(μV)]	c.f [dB(1/m)]	Result [dB(μV/m)]	Limit [dB(μV/m)]	Margin [dB]	Height [cm]	Angle [°]
1	127.508	40.7	-6.9	33.8	43.5	9.7	148.4	92.8
2	144.000	39.2	-5.8	33.4	43.5	10.1	226.4	237.9
3	157.501	38.0	-4.9	33.1	43.5	10.4	185.6	246.0
4	192.807	36.6	-3.4	33.2	43.5	10.3	155.3	92.4
5	409.698	31.9	-2.9	29.0	46.0	17.0	399.2	218.8
6	457.901	40.5	-2.3	38.2	46.0	7.8	100.0	187.1

--- Vertical Polarization (QP)---

No.	Frequency [MHz]	Reading [dB(μV)]	c.f [dB(1/m)]	Result [dB(μV/m)]	Limit [dB(μV/m)]	Margin [dB]	Height [cm]	Angle [°]
1	30.626	38.2	-4.7	33.5	40.0	6.5	100.0	213.1
2	48.206	36.5	-8.8	27.7	40.0	12.3	100.0	42.3
3	50.180	35.8	-9.8	26.0	40.0	14.0	100.0	347.2
4	81.005	42.6	-13.8	28.8	40.0	11.2	118.5	276.0
5	101.887	43.1	-9.8	33.3	43.5	10.2	100.0	202.7
6	127.514	38.1	-6.9	31.2	43.5	12.3	100.0	352.8

MHL mode

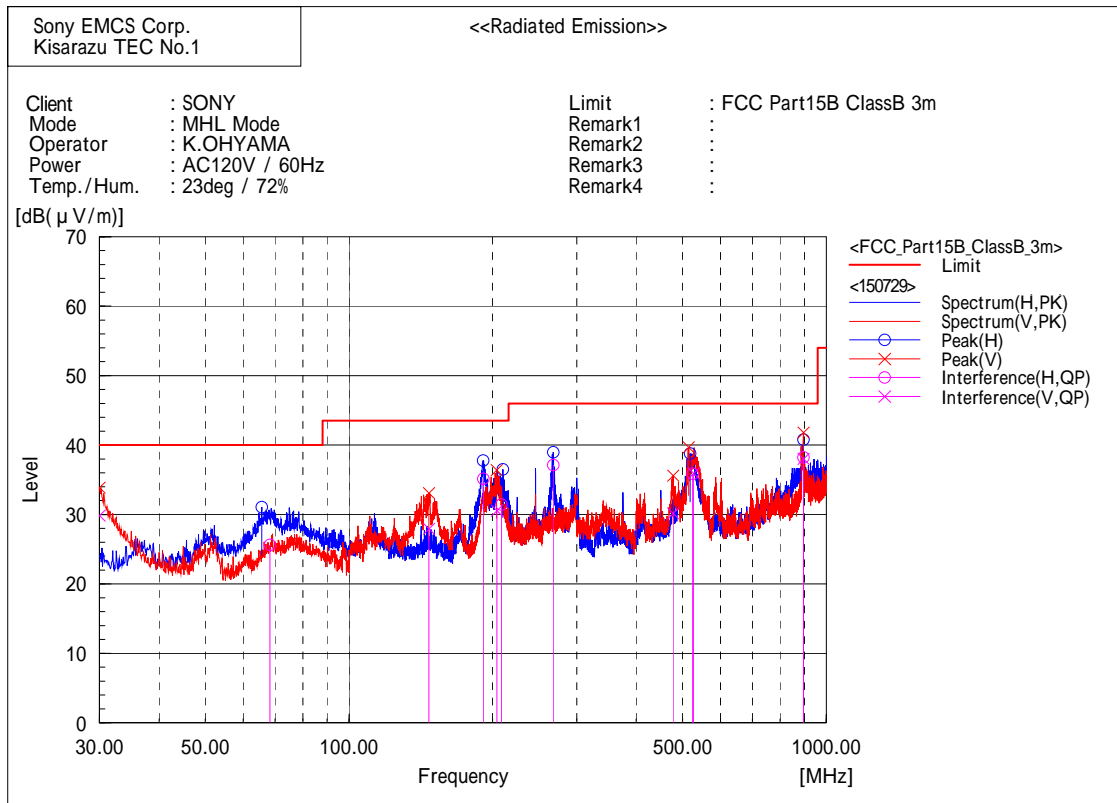

Final Result

--- Horizontal Polarization (QP)---

No.	Frequency [MHz]	Reading [dB(μV)]	c.f [dB(1/m)]	Result [dB(μV/m)]	Limit [dB(μV/m)]	Margin [dB]	Height [cm]	Angle [°]
1	68.316	40.7	-15.1	25.6	40.0	14.4	242.0	176.3
2	191.093	38.6	-3.5	35.1	43.5	8.4	157.6	157.9
3	208.482	34.1	-2.7	31.4	43.5	12.1	100.0	141.2
4	267.939	37.7	-0.6	37.1	46.0	8.9	100.0	143.9
5	524.699	37.6	-1.7	35.9	46.0	10.1	238.1	120.8
6	895.424	34.4	3.9	38.3	46.0	7.7	138.0	241.0

--- Vertical Polarization (QP)---

No.	Frequency [MHz]	Reading [dB(μV)]	c.f [dB(1/m)]	Result [dB(μV/m)]	Limit [dB(μV/m)]	Margin [dB]	Height [cm]	Angle [°]
1	30.000	34.4	-4.6	29.8	40.0	10.2	100.0	169.9
2	147.079	33.4	-5.5	27.9	43.5	15.6	100.0	180.9
3	204.168	33.5	-2.9	30.6	43.5	12.9	207.6	165.9
4	477.624	32.2	-2.0	30.2	46.0	15.8	100.0	159.9
5	527.428	37.6	-1.7	35.9	46.0	10.1	235.4	199.1
6	895.407	34.1	3.9	38.0	46.0	8.0	138.0	192.7

Above 1GHz
 1 GHz - 6 GHz (Peak)
 PC Communication mode

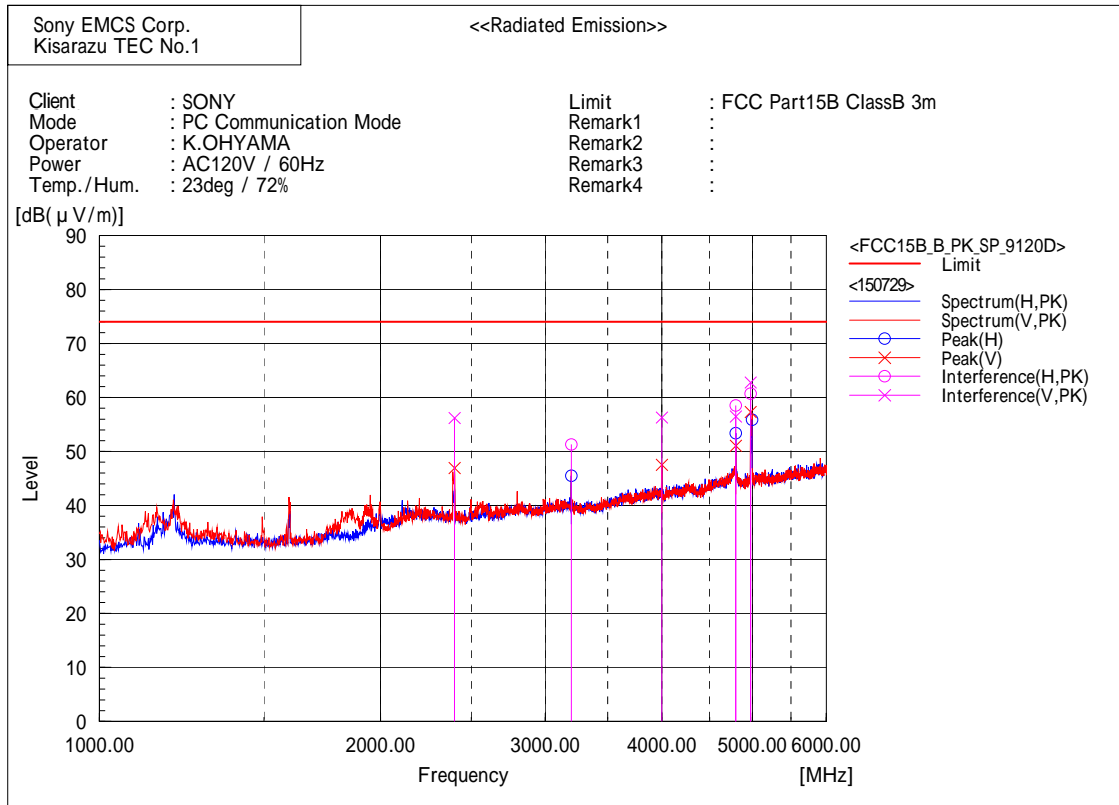

Final Result

--- Horizontal Polarization (PK)---

No.	Frequency [MHz]	Reading [dB(μV)]	c.f [dB(1/m)]	Result [dB(μV/m)]	Limit [dB(μV/m)]	Margin [dB]	Height [cm]	Angle [°]
1	3199.569	54.5	-3.2	51.3	74.0	22.7	136.7	209.7
2	4799.329	55.9	2.6	58.5	74.0	15.5	103.3	310.2
3	4977.529	58.6	2.1	60.7	74.0	13.3	373.2	323.7

--- Vertical Polarization (PK)---

No.	Frequency [MHz]	Reading [dB(μV)]	c.f [dB(1/m)]	Result [dB(μV/m)]	Limit [dB(μV/m)]	Margin [dB]	Height [cm]	Angle [°]
1	2399.537	63.3	-7.1	56.2	74.0	17.8	135.4	335.5
2	3999.283	56.5	-0.2	56.3	74.0	17.7	100.0	37.0
3	4799.881	53.9	2.6	56.5	74.0	17.5	354.0	23.1
4	4977.339	60.7	2.1	62.8	74.0	11.2	216.8	28.0

1 GHz - 6 GHz (Average)
PC Communication mode

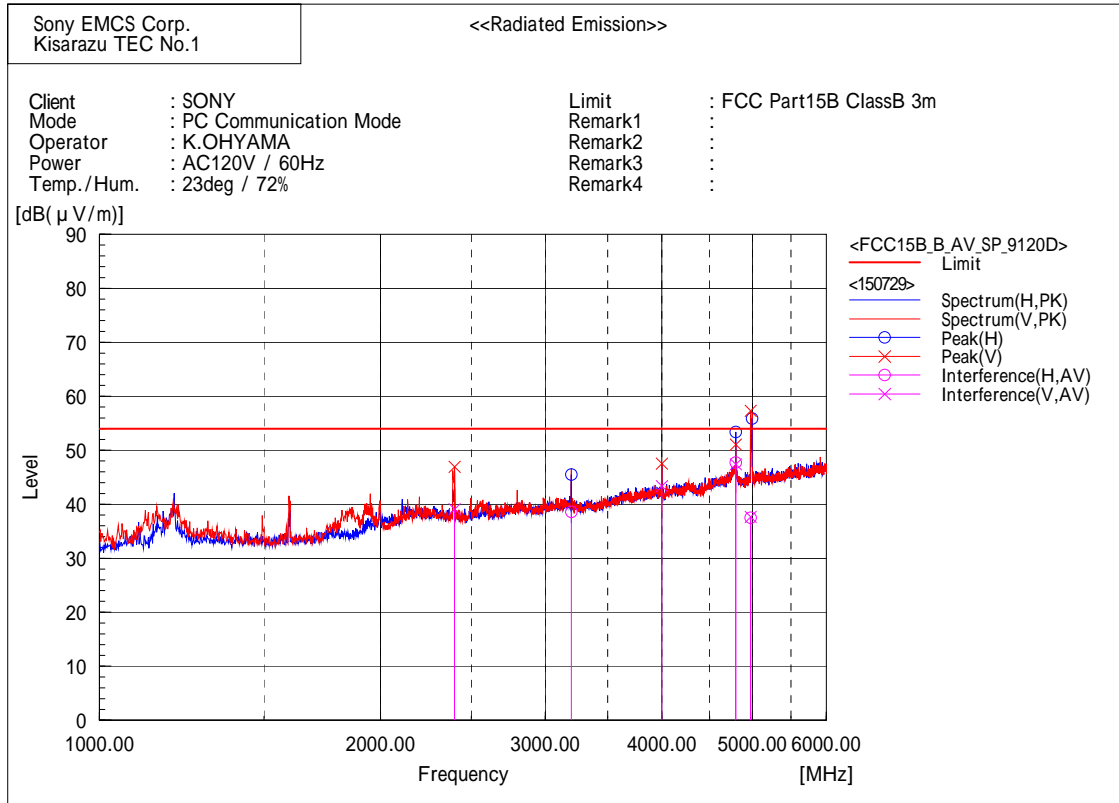

Final Result

--- Horizontal Polarization (AV)---

No.	Frequency [MHz]	Reading [dB(μV)]	c.f [dB(1/m)]	Result [dB(μV/m)]	Limit [dB(μV/m)]	Margin [dB]	Height [cm]	Angle [°]
1	3199.757	41.8	-3.2	38.6	54.0	15.4	136.7	209.6
2	4799.568	45.2	2.6	47.8	54.0	6.2	103.3	310.1
3	4978.343	35.4	2.1	37.5	54.0	16.5	373.2	323.7

--- Vertical Polarization (AV)---

No.	Frequency [MHz]	Reading [dB(μV)]	c.f [dB(1/m)]	Result [dB(μV/m)]	Limit [dB(μV/m)]	Margin [dB]	Height [cm]	Angle [°]
1	2399.730	46.2	-7.1	39.1	54.0	14.9	135.4	335.4
2	3999.596	43.6	-0.2	43.4	54.0	10.6	100.0	37.0
3	4799.520	44.8	2.6	47.4	54.0	6.6	353.8	23.1
4	4978.224	35.6	2.1	37.7	54.0	16.3	216.7	28.0

6 GHz - 10 GHz (Peak)
PC Communication mode

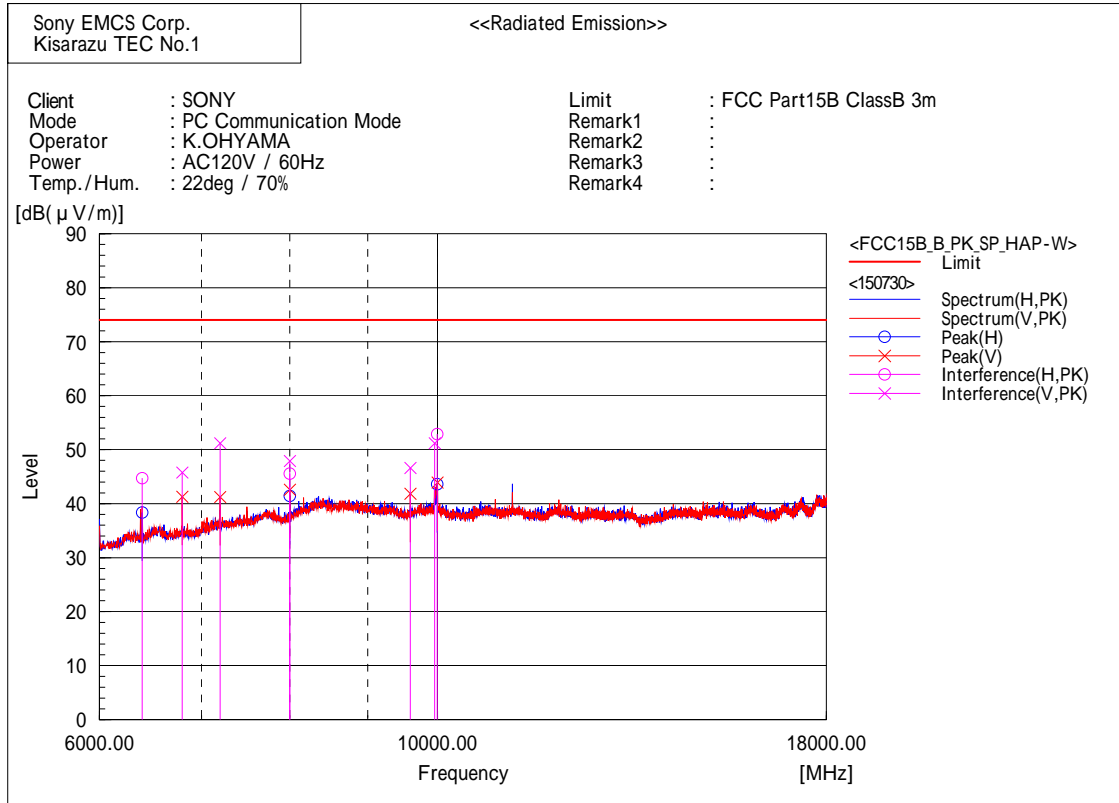

Final Result

--- Horizontal Polarization (PK)---

No.	Frequency [MHz]	Reading [dB(μV)]	c.f [dB(1/m)]	Result [dB(μV/m)]	Limit [dB(μV/m)]	Margin [dB]	Height [cm]	Angle [°]
1	6399.139	55.5	-10.8	44.7	74.0	29.3	217.6	359.9
2	7999.105	54.0	-8.5	45.5	74.0	28.5	163.4	205.5
3	9997.122	58.0	-5.1	52.9	74.0	21.1	164.6	50.8

--- Vertical Polarization (PK)---

No.	Frequency [MHz]	Reading [dB(μV)]	c.f [dB(1/m)]	Result [dB(μV/m)]	Limit [dB(μV/m)]	Margin [dB]	Height [cm]	Angle [°]
1	6799.173	57.1	-11.3	45.8	74.0	28.2	272.6	6.7
2	7199.622	61.6	-10.4	51.2	74.0	22.8	180.6	30.3
3	7999.071	56.4	-8.5	47.9	74.0	26.1	261.2	329.3
4	9598.903	52.5	-5.9	46.6	74.0	27.4	294.8	12.4
5	9956.867	56.3	-5.1	51.2	74.0	22.8	317.7	13.6

6 GHz - 10 GHz (Average)
PC Communication mode

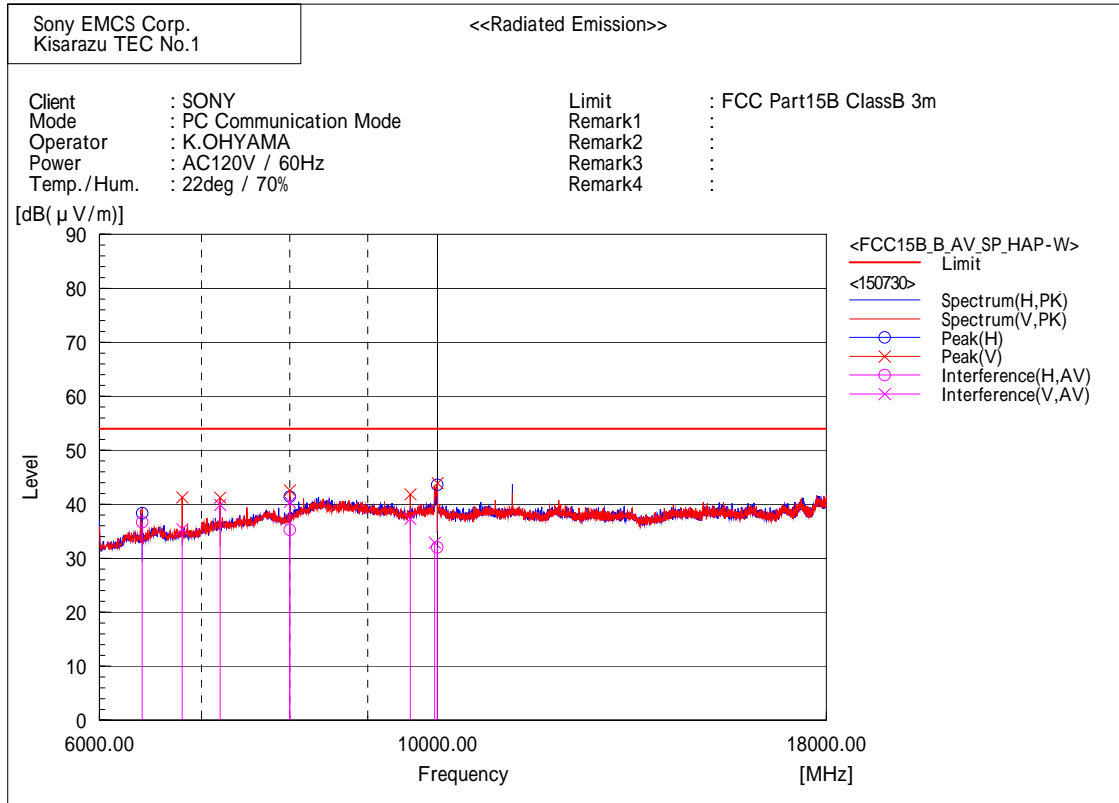

Final Result

--- Horizontal Polarization (AV)---

No.	Frequency [MHz]	Reading [dB(μV)]	c.f [dB(1/m)]	Result [dB(μV/m)]	Limit [dB(μV/m)]	Margin [dB]	Height [cm]	Angle [°]
1	6399.366	47.5	-10.8	36.7	54.0	17.3	217.6	359.8
2	7999.236	43.8	-8.5	35.3	54.0	18.7	163.4	205.5
3	9996.734	37.1	-5.1	32.0	54.0	22.0	164.6	50.8

--- Vertical Polarization (AV)---

No.	Frequency [MHz]	Reading [dB(μV)]	c.f [dB(1/m)]	Result [dB(μV/m)]	Limit [dB(μV/m)]	Margin [dB]	Height [cm]	Angle [°]
1	6799.352	46.7	-11.3	35.4	54.0	18.6	272.5	6.8
2	7199.296	50.3	-10.4	39.9	54.0	14.1	180.6	30.4
3	7999.242	48.9	-8.5	40.4	54.0	13.6	261.2	329.2
4	9599.063	43.2	-5.9	37.3	54.0	16.8	294.7	12.5
5	9956.680	38.0	-5.1	32.9	54.0	21.1	317.6	13.7

1 GHz - 6 GHz (Peak)
MHL mode

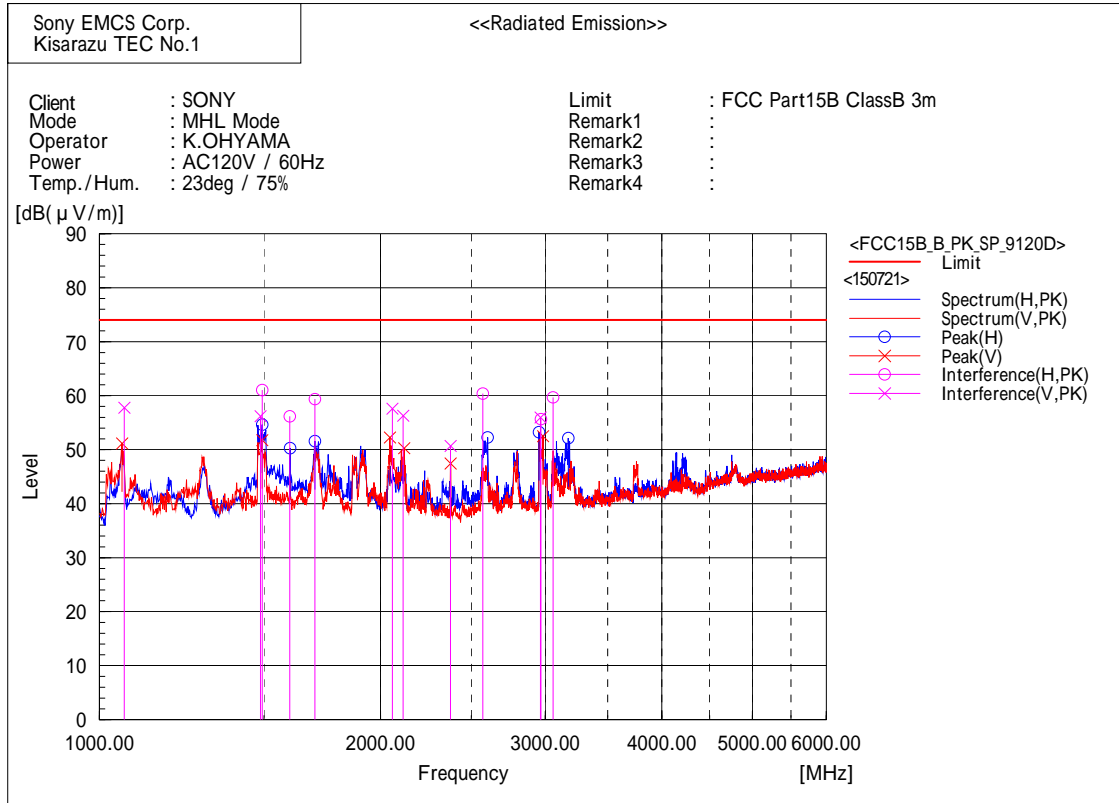

Final Result

--- Horizontal Polarization (PK)---

No.	Frequency [MHz]	Reading [dB(μV)]	c.f [dB(1/m)]	Result [dB(μV/m)]	Limit [dB(μV/m)]	Margin [dB]	Height [cm]	Angle [°]
1	1493.594	72.0	-11.0	61.0	74.0	13.0	226.0	223.0
2	1599.059	67.1	-10.9	56.2	74.0	17.8	124.9	219.1
3	1700.747	70.0	-10.7	59.3	74.0	14.7	147.3	209.7
4	2573.604	66.6	-6.2	60.4	74.0	13.6	143.5	206.9
5	2969.992	60.0	-4.4	55.6	74.0	18.4	142.3	169.9
6	3059.226	63.3	-3.6	59.7	74.0	14.3	262.5	122.8

--- Vertical Polarization (PK)---

No.	Frequency [MHz]	Reading [dB(μV)]	c.f [dB(1/m)]	Result [dB(μV/m)]	Limit [dB(μV/m)]	Margin [dB]	Height [cm]	Angle [°]
1	1063.390	70.4	-12.6	57.8	74.0	16.2	106.0	167.6
2	1487.032	67.1	-10.9	56.2	74.0	17.8	110.4	166.8
3	2058.117	66.1	-8.5	57.6	74.0	16.4	417.6	185.5
4	2113.525	64.0	-7.7	56.3	74.0	17.7	309.5	183.4
5	2375.921	57.8	-7.1	50.7	74.0	23.3	112.6	176.2
6	2965.585	60.4	-4.4	56.0	74.0	18.0	100.0	168.9

1 GHz - 6 GHz (Average)
MHL mode

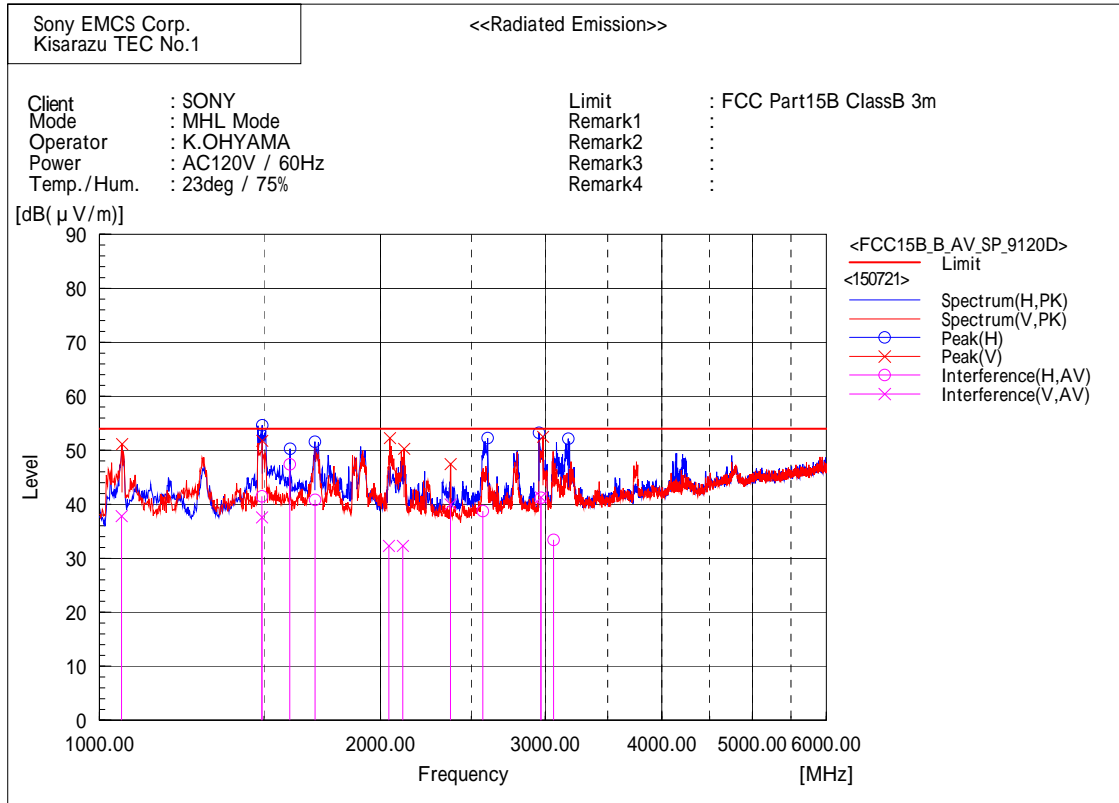

Final Result

--- Horizontal Polarization (AV)---

No.	Frequency [MHz]	Reading [dB(µV)]	c.f [dB(1/m)]	Result [dB(µV/m)]	Limit [dB(µV/m)]	Margin [dB]	Height [cm]	Angle [°]
1	1492.612	52.5	-11.0	41.5	54.0	12.5	231.8	222.0
2	1598.879	58.3	-10.9	47.4	54.0	6.6	124.9	219.1
3	1701.425	51.5	-10.7	40.8	54.0	13.2	147.3	209.7
4	2573.271	45.0	-6.2	38.8	54.0	15.2	143.5	206.9
5	2970.060	45.6	-4.4	41.2	54.0	12.8	142.3	170.0
6	3063.400	37.0	-3.6	33.4	54.0	20.6	262.4	122.9

--- Vertical Polarization (AV)---

No.	Frequency [MHz]	Reading [dB(µV)]	c.f [dB(1/m)]	Result [dB(µV/m)]	Limit [dB(µV/m)]	Margin [dB]	Height [cm]	Angle [°]
1	1055.976	50.4	-12.6	37.8	54.0	16.2	106.0	167.7
2	1492.482	48.6	-11.0	37.6	54.0	16.4	110.4	166.9
3	2039.993	41.1	-8.8	32.3	54.0	21.7	417.4	185.6
4	2111.889	40.0	-7.7	32.3	54.0	21.7	309.4	183.5
5	2375.961	47.1	-7.1	40.0	54.0	14.0	112.6	176.3
6	2970.180	45.7	-4.4	41.3	54.0	12.7	100.0	168.1

6 GHz - 10 GHz (Peak)
MHL mode

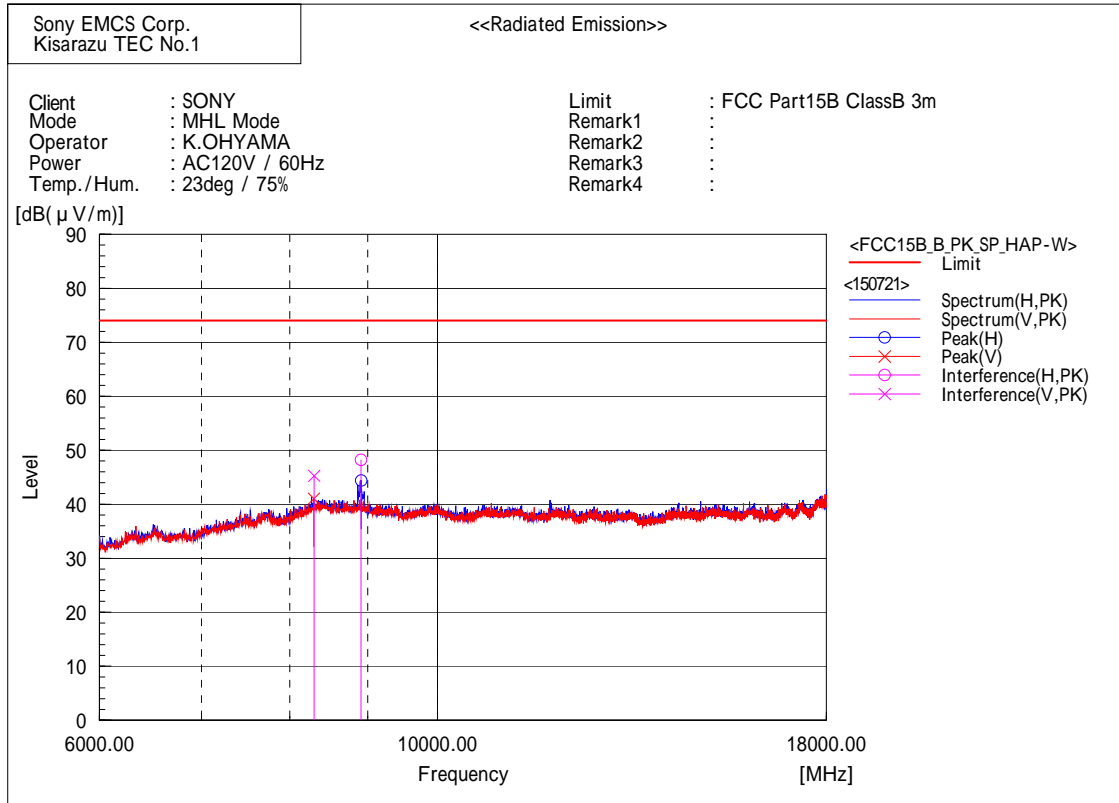

Final Result

--- Horizontal Polarization (PK)---

No.	Frequency [MHz]	Reading [dB(μV)]	c. f [dB(1/m)]	Result [dB(μV/m)]	Limit [dB(μV/m)]	Margin [dB]	Height [cm]	Angle [°]
1	8909.502	54.7	-6.5	48.2	74.0	25.8	240.1	147.0

--- Vertical Polarization (PK)---

No.	Frequency [MHz]	Reading [dB(μV)]	c. f [dB(1/m)]	Result [dB(μV/m)]	Limit [dB(μV/m)]	Margin [dB]	Height [cm]	Angle [°]
1	8297.942	52.4	-7.1	45.3	74.0	28.7	330.2	11.1

6 GHz - 10 GHz (Average)
MHL mode

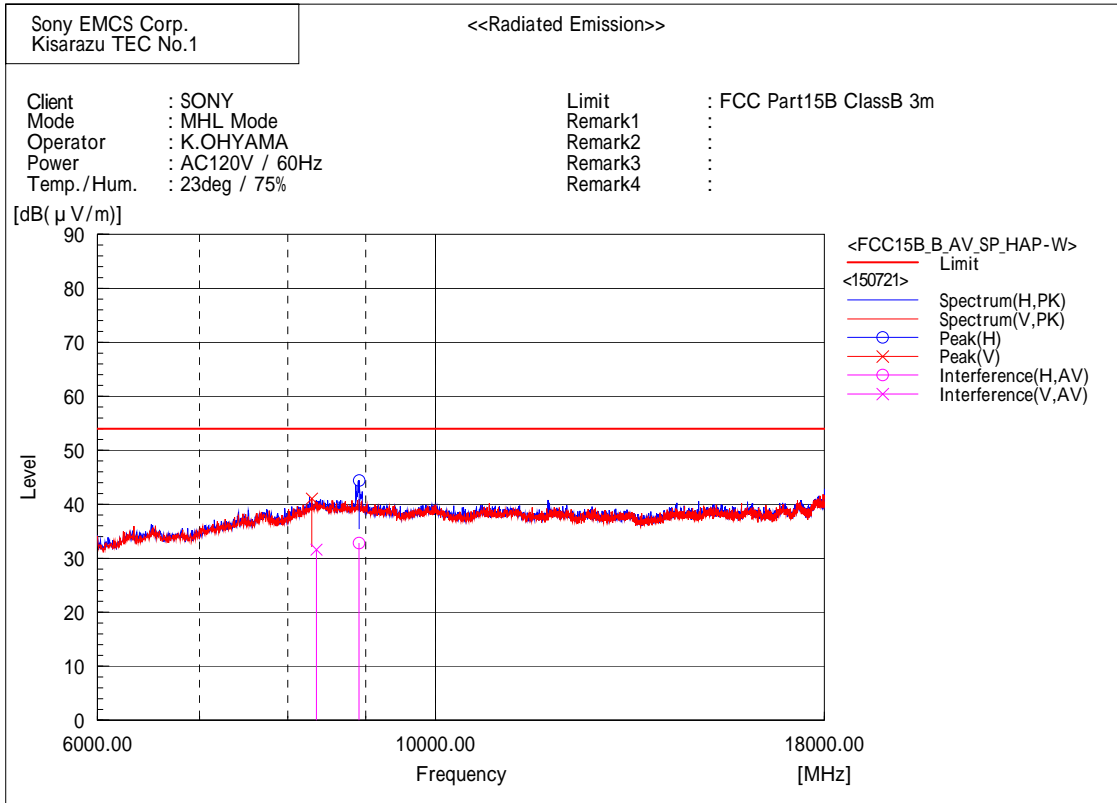

Final Result

--- Horizontal Polarization (AV)---

No.	Frequency [MHz]	Reading [dB(μV)]	c. f [dB(1/m)]	Result [dB(μV/m)]	Limit [dB(μV/m)]	Margin [dB]	Height [cm]	Angle [°]
1	8910.013	39.3	-6.5	32.8	54.0	21.2	238.8	145.9

--- Vertical Polarization (AV)---

No.	Frequency [MHz]	Reading [dB(μV)]	c. f [dB(1/m)]	Result [dB(μV/m)]	Limit [dB(μV/m)]	Margin [dB]	Height [cm]	Angle [°]
1	8351.724	38.4	-6.8	31.6	54.0	22.4	330.0	11.1

6. List of Test Equipment

All test results are traceable to the national and/or international standards.

* In case the margin in peak detection mode was more than 6 dB, we reported the data in the spectrum analyzer as final result.

Note: Marked "S" is used on Spectrum measurement. Marked "F" is used on Final Measurement.

EMI Shielded Room 1

	Control No.	Equipment	Model No.	Manufacture	Serial No.	Cal.Int.	Last Cal.
<input checked="" type="checkbox"/>	F	-	-	Otsuka Science	9407838	-	-
<input checked="" type="checkbox"/>	F	M484	EMI Receiver	ESCI	Rohde&Schwarz	100607	12 14.09.25
<input checked="" type="checkbox"/>	F	CS015	3m CE Cable SYS	None	TOYO Corporation	None	12 14.10.01
<input checked="" type="checkbox"/>	F	M569	HIGH FREQUENCY FUSE	MP612A	Anritsu	None	12 14.10.01
<input checked="" type="checkbox"/>	F	M663	6dB Attenuator	6806.01.A	HUBER+SUHNER	None	12 14.10.01
<input checked="" type="checkbox"/>	F	M130	RF Selector	NS4903	Toyo	0109001	12 14.10.01
<input type="checkbox"/>	F	M605	LISN	ENV216	Rohde & Schwarz	101305	12 15.07.10
<input checked="" type="checkbox"/>	F	M606	LISN (for EUT)	ENV216	Rohde & Schwarz	101306	12 15.06.30
<input checked="" type="checkbox"/>	F	M111	LISN (for Peripheral)	ESH3-Z5	Rohde & Schwarz	100062	12 14.09.15
<input checked="" type="checkbox"/>	F	M621	LISN (for Peripheral)	KNW-407	Kyoritsu	8-665-11	12 14.09.19
<input checked="" type="checkbox"/>	F	M056	50 ohm Terminator (for M111)	CT-01	TME	None	12 15.01.30
<input checked="" type="checkbox"/>	F	M155	50 ohm Terminator (for M621)	T1302	Stack	None	12 15.01.30
<input type="checkbox"/>	F	M166	50 ohm Terminator	T1302	Stack	None	12 15.01.30
<input checked="" type="checkbox"/>	F	M688	Thermo Meter	AD-5640A	AND	201302	12 14.10.06

3 meters Semi-Anechoic Chamber 1

	Control No.	Equipment	Model No.	Manufacture	Serial No.	Cal.Int.	Last Cal.
<input checked="" type="checkbox"/>	F	M115	Semi-Anechoic Chamber	None	Otsuka Science	7D1-8A11	12 14.10.01
<input checked="" type="checkbox"/>	F	M685	EMI Receiver	N9038A	Agilent Technologies	MY52260159	12 14.11.18
<input checked="" type="checkbox"/>	F	A089	Biconical Antenna	BBA9106	Schwarzbeck	VHA91032835	12 15.01.29
<input checked="" type="checkbox"/>	F	A088	Logperiodic Antenna	UHALP9108	Schwarzbeck	0643	12 15.01.30
<input checked="" type="checkbox"/>	F	A064	Horn Antenna	BBHA9120D	Schwarzbeck	746	12 15.01.26
<input checked="" type="checkbox"/>	F	A078	Horn Antenna	HAP06-18W	TOYO Corporation	00000070	12 15.02.17
<input type="checkbox"/>	F	A026	Horn Antenna	BBHA9120B	Schwarzbeck	222	12 15.01.26
<input checked="" type="checkbox"/>	F	CS017	3m RE Cable SYS1	None	TOYO Corporation	None	12 14.10.01
<input checked="" type="checkbox"/>	F	CS018	3m RE Cable SYS2	None	TOYO Corporation	None	12 14.10.01
<input checked="" type="checkbox"/>	F	M128	Attenuator (3dB)	8491A	Agilent	53541	12 14.10.01
<input checked="" type="checkbox"/>	F	M127	RF Pre-Amp	8447D	Hewlet-Packerd	2944A10241	12 14.10.01
<input checked="" type="checkbox"/>	F	M124	RF Selector	NS4903DR	TOYO Corporation	0109022	12 14.10.01
<input checked="" type="checkbox"/>	F	M609	Attenuator	8491B	Agilent	100050	12 14.10.01
<input checked="" type="checkbox"/>	F	M126	Step Attenuator	8494H	Hewlet-Packerd	100050	12 14.10.01
<input checked="" type="checkbox"/>	F	M129	RF Pre-Amp	TPA0108-40	TOYO Corporation	100050	12 14.10.01
<input type="checkbox"/>	F	M546	BAND REJECT FILTER	NF-49BT	TOYO Corporation	001	12 14.10.01
<input checked="" type="checkbox"/>	F	M687	Thermo Meter	AD-5640A	AND	201301	12 14.10.06

Measurement software

	Control No.	Description	Model No.	Ver. No.	Manufacturer
<input checked="" type="checkbox"/>	F	SW-010	Conducted Emission Software	EP5/ CE	5.0.0 TOYO Corporation
<input checked="" type="checkbox"/>	F	SW-009	Radiated Emission Software	V-Scan	4.0.30 TOYO Corporation

About calibration interval

Valid until the day of the month, 1 year from the calibration