



FCC/IC RF Test Report

APPLICANT : Sony Mobile Communications Inc.
EQUIPMENT : Smart phone
BRAND NAME : SONY
TYPE NAME : PM-0860-BV
FCC ID : PY7-PM0860
IC : 4170B-PM0860
STANDARD : FCC Part 15 Subpart C §15.225;
IC RSS-210 issue 8
CLASSIFICATION : (DXX) Low Power Communication Device Transmitter

The testing was completed on Jan. 06, 2015. We, SPORTON INTERNATIONAL INC., would like to declare that the tested sample has been evaluated in accordance with the test procedures and has been in compliance with the applicable technical standards.

The test results in this report apply exclusively to the tested model / sample. Without written approval of SPORTON INTERNATIONAL INC., the test report shall not be reproduced except in full.

Reviewed by: Joseph Lin / Supervisor

Approved by: Jones Tsai / Manager



SPORTON INTERNATIONAL INC.

No. 52, Hwa Ya 1st Rd., Hwa Ya Technology Park, Kwei-Shan District, Tao Yuan City, Taiwan, R.O.C.

SPORTON INTERNATIONAL INC.

TEL : 886-3-327-3456

FAX : 886-3-328-4978

FCC ID : PY7-PM0860

IC: 4170B-PM0860

Page Number : 1 of 18

Report Issued Date : Mar. 13, 2015

Report Version : Rev. 01

Report Template No.: BU5-FR15CNFC Version 1.0

Report Template No.: BU5-CR210NFC Version 1.0



Table of Contents

SUMMARY OF THE TEST RESULT4
1. GENERAL INFORMATION.....5
1.1 Applicant.....5
1.2 Manufacturer.....5
1.3 Product Details5
1.4 Modification of EUT.....6
1.5 Testing Location.....7
1.6 Applicable Standards7
1.7 Test Modes7
1.8 Test Configurations.....8
1.9 Table for Supporting Units9
2. CONDUCTED EMISSION TEST.....10
2.1 Measuring Instruments.....10
2.2 Test setup.....10
2.3 Test Result of Conducted Emission Test.....10
2.4 AC Power Line Conducted Emissions Measurement11
3. CONDUCTED TEST ITEMS12
3.1 Measuring Instruments.....12
3.2 Test Setup12
3.3 Test Result of Conducted Test Items12
3.4 20dB Spectrum Bandwidth Measurement13
3.5 Frequency Stability Measurement13
4. RADIATED TEST ITEMS.....14
4.1 Measuring Instruments.....14
4.2 Test Setup14
4.3 Test Result of Radiated Test Items14
4.4 Field Strength of Fundamental Emissions and Mask Measurement15
4.5 Radiated Emissions Measurement.....16
5. LIST OF MEASURING EQUIPMENT18
APPENDIX A. TEST RESULTS OF CONDUCTED EMISSION TEST
APPENDIX B. TEST RESULTS OF CONDUCTED TEST ITEMS
B.1. Test Result of 20dB Spectrum Bandwidth
B.2 Test Result of Frequency Stability
APPENDIX C. TEST RESULTS OF RADIATED TEST ITEMS
C.1 Test Result of Field Strength of Fundamental Emissions
C.2 Results of Radiated Emissions (9 kHz~30MHz)
C.3 Results of Radiated Emissions (30MHz~1GHz)



REVISION HISTORY

REPORT NO.	VERSION	DESCRIPTION	ISSUED DATE
FR4D3145D	Rev. 01	Initial issue of report	Mar. 13, 2015



SUMMARY OF THE TEST RESULT

Applied Standard: 47 CFR FCC Part 15 Subpart C / IC RSS-210 issue 8					
Part	FCC Rule	IC Rule	Description of Test	Result	Under Limit
3.1	15.207	Gen 7.2.4	AC Power Line Conducted Emissions	Complies	5.50 dB at 13.558 MHz
3.2	15.225(a)(b)(c)	A2.6	Field Strength of Fundamental Emissions	Complies	71.91 dB at 13.560 MHz
3.3	2.1049	-	20dB Spectrum Bandwidth	Complies	-
3.4	15.225(d) 15.209	A2.6	Radiated Emissions	Complies	31.14 dB at 0.505 MHz for Quasi-Peak
3.5	15.225(e)	A2.6	Frequency Stability	Complies	-
3.6	15.203	-	Antenna Requirements	Complies	-

Test Items	Uncertainty	Remark
AC Power Line Conducted Emissions	±2.26dB	Confidence levels of 95%
Radiated Emissions (30MHz~1000MHz)	±4.70dB	Confidence levels of 95%



1. GENERAL INFORMATION

1.1 Applicant

Sony Mobile Communications Inc.
Nya Vattentornet, 22188 Lund, Sweden

1.2 Manufacturer

Arima Communications Corp.
6F, No.866, Jhongjheng Rd., Jhonghe Dist., New Taipei City 23586, Taiwan

1.3 Product Details

Items	Description
Tx/Rx Frequency Range	13.553 ~ 13.567MHz
Channel Number	1
20dBW	2.64kHz
99%OBW	2.24kHz
Antenna Type	Loop Antenna
Type of Modulation	ASK

Remark: The above EUT's information was declared by manufacturer. Please refer to the specifications or user's manual for more detailed description.

EUT Information List				
IMEI	HW Version	SW Version	S/N	Performed Test Item
IMEI: 004402453631180	A	27.1.A.0.38	RV4C13D10872	Frequency Stability Radiated Spurious Emission AC Conducted Emission



Accessory List	
AC Adapter	Model No. : EP800
	Type No. : AC-0030-US
	S/N : 3113W46622783 (for Radiated Spurious Emission)
	S/N : 3114W37321262 (for Conducted Emission)
Battery	Model No. : Ram
Earphone	Model No. : MH410c
	Type No. : AG-1103
	S/N : 1411204C00BC7D0 (for Radiated Spurious Emission)
	S/N : 1411204C00BCC46 (for Conducted Emission)
USB Cable 1	Model No. : EC450
	Type No. : AI-0700
	S/N : 143912D8330504A

Note:

1. Above EUT list and accessory list used are electrically identical per declared by manufacturer.
2. Above the accessories list are used to exercise the EUT during test.
3. For other wireless features of this EUT, test report will be issued separately.

1.4 Modification of EUT

No modifications are made to the EUT during all test items.

1.5 Testing Location

Sporton Lab is accredited to ISO 17025 by Taiwan Accreditation Foundation (TAF code : 1190) and the FCC designation No. TW1022 under the FCC 2.948(e) by Mutual Recognition Agreement (MRA) in FCC Test.

Test Site	SPORTON INTERNATIONAL INC.			
Test Site Location	No. 52, Hwa Ya 1 st Rd., Hwa Ya Technology Park, Kwei-Shan District, Tao Yuan City, Taiwan, R.O.C. TEL: +886-3-3273456 / FAX: +886-3-3284978			
Test Site No.	Sporton Site No.			IC Registration No.
	TH02-HY	CO05-HY	03CH07-HY	
Test Engineer	Danny Chen	Eric Jeng	Nick Yu	4086B-1
Temperature	22~24	21~23	21~23	
Relative Humidity	53~55	46~48	47~49	

Note: The test site complies with ANSI C63.4 2009 requirement.

1.6 Applicable Standards

According to the specifications of the manufacturer, the EUT must comply with the requirements of the following standards:

- FCC Part 15 Subpart C §15.225
- ANSI C63.10-2013
- IC RSS-210 Issue 8

1.7 Test Modes

Investigation has been done on all the possible configurations for searching the worst cases. The following table is a list of the test modes shown in this test report.

Test Items	
AC Power Line Conducted Emissions	Field Strength of Fundamental Emissions
20dB Spectrum Bandwidth	Frequency Stability
Radiated Emissions 9kHz~30MHz	Radiated Emissions 30MHz~1GHz
Note:	
1. The EUT was programmed to be in continuously transmitting mode.	
2. The ancillary equipment, NFC card, is used to make the EUT (NFC) continuously transmit at 13.56MHz and is placed around 3 cm gap to the EUT.	

1.8 Test Configurations

<AC Conducted Emissions>

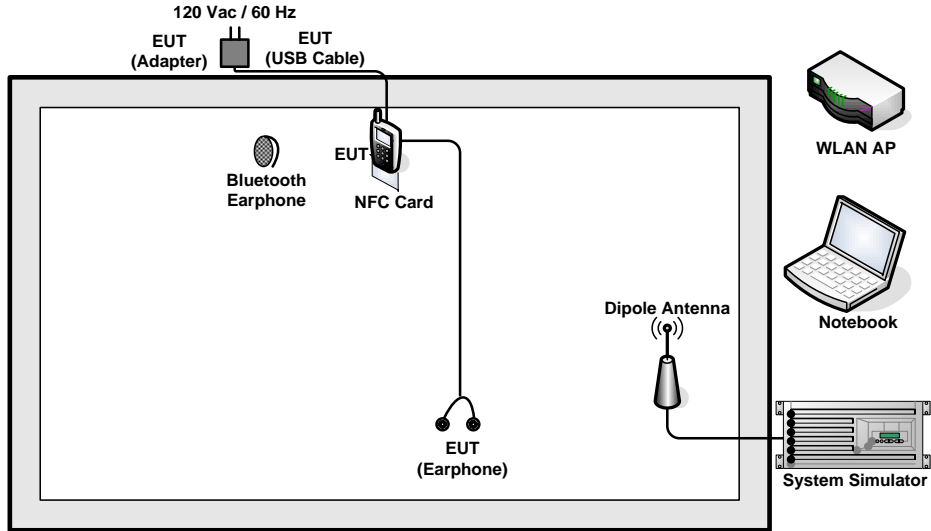

< For Fundamental Emissions and Mask and Radiated Emissions Measurement >

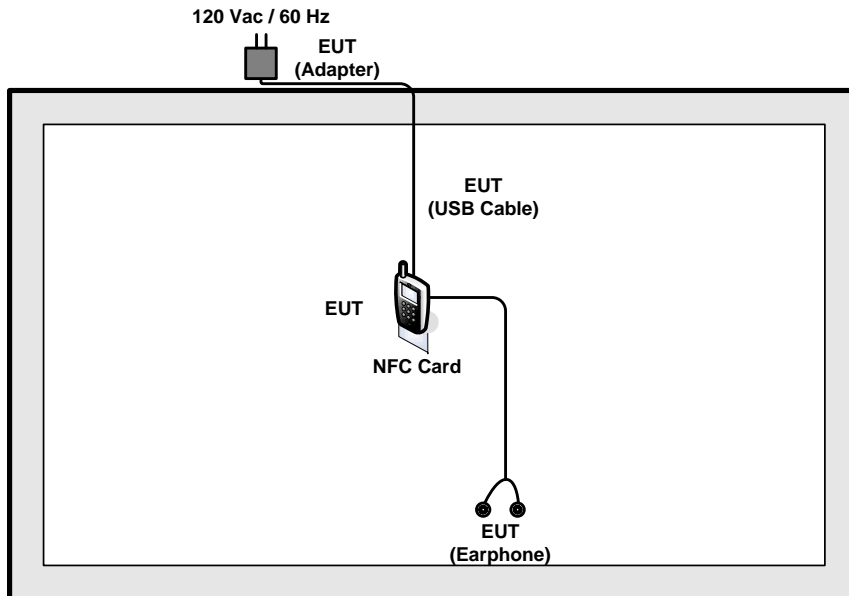

**1.9 Table for Supporting Units**

Item	Equipment	Trade Name	Model Name	FCC ID	Data Cable	Power Cord
1.	System Simulator	Anritsu	MT8820C	N/A	N/A	Unshielded, 1.8 m
2.	WLAN AP	D-Link	DIR-628	KA2DIR628A2	N/A	Unshielded, 1.8 m
3.	Bluetooth Earphone	Sony	SBH20	PY7-RD0010	Unshielded, 0.75m	N/A
4.	Notebook	DELL	Latitude E6320	FCC DoC/ Contains FCC ID: QDS-BRCM1054	N/A	AC I/P: Unshielded, 1.2 m DC O/P: Shielded, 1.8 m
5.	NFC Card	Metro Taipei	Easy Card	N/A	N/A	N/A
6.	SD Card	SanDisk	MicroSD HC	FCC DoC	N/A	N/A

2. CONDUCTED EMISSION TEST

2.1 Measuring Instruments

See list of measuring instruments of this test report.

2.2 Test setup

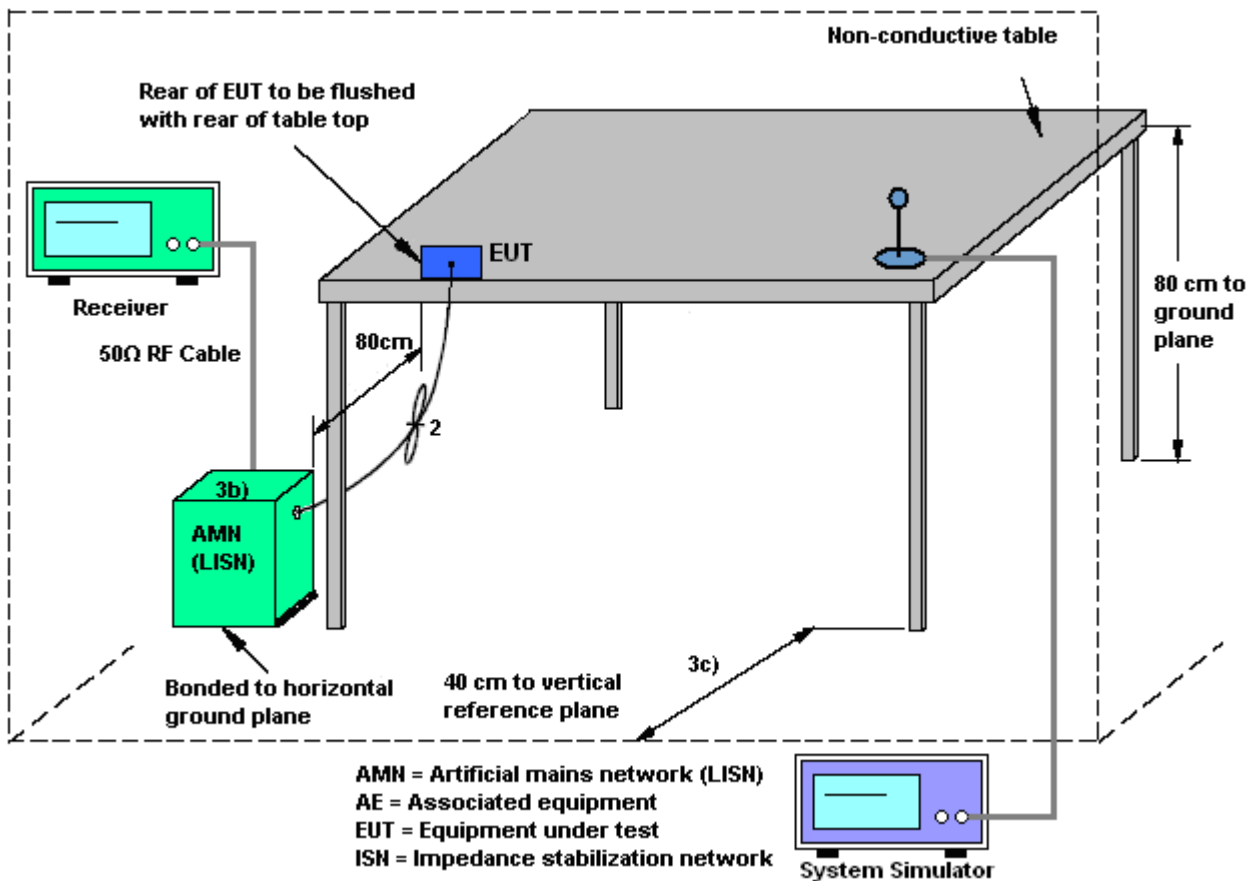

2.3 Test Result of Conducted Emission Test

Please refer to Appendix A.



2.4 AC Power Line Conducted Emissions Measurement

Limit

For equipment that is designed to be connected to the public utility (AC) power line, the radio frequency voltage that is conducted back onto the AC power line on any frequency or frequencies within the band 150 kHz to 30 MHz shall not exceed the limits in the following table.

Frequency of Emission (MHz)	Conducted Limit (dB μ V)	
	Quasi-Peak	Average
0.15-0.5	66 to 56*	56 to 46*
0.5-5	56	46
5-30	60	50

*Decreases with the logarithm of the frequency.

Test Procedures

1. The EUT was placed 0.4 meter from the conducting wall of the shielding room, and it was kept at least 80 centimeters from any other grounded conducting surface.
2. Connect EUT to the power mains through a line impedance stabilization network (LISN).
3. All the support units are connecting to the other LISN.
4. The LISN provides 50 ohm coupling impedance for the measuring instrument.
5. The FCC states that a 50 ohm, 50 microhenry LISN should be used.
6. Both sides of AC line were checked for maximum conducted interference.
7. The frequency range from 150 kHz to 30 MHz was searched.
8. Set the test-receiver system to Peak Detect Function and specified bandwidth (IF Bandwidth = 9kHz) with Maximum Hold Mode. Then measurement is also conducted by Average Detector and Quasi-Peak Detector Function respectively.

3. CONDUCTED TEST ITEMS

3.1 Measuring Instruments

See list of measuring instruments of this test report.

3.2 Test Setup

20dB Spectrum Bandwidth

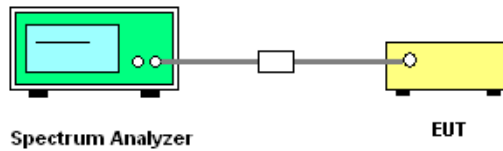

Frequency Stability

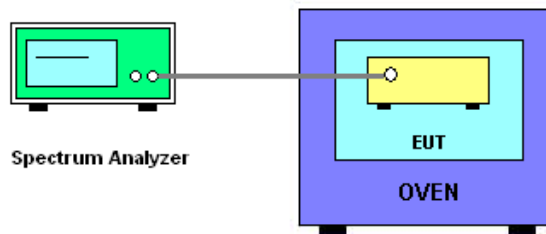

3.3 Test Result of Conducted Test Items

Please refer to Appendix B.



3.4 20dB Spectrum Bandwidth Measurement

Limit

Intentional radiators must be designed to ensure that the 20 dB bandwidth of the emissions in the specific band 13.553~13.567MHz

Test Procedures

1. The transmitter output (antenna port) was connected to the spectrum analyzer in peak Max hold mode.
2. The resolution bandwidth of 1 kHz and the video bandwidth of 3 kHz were used.
3. Measured the spectrum width with power higher than 20dB below carrier.

3.5 Frequency Stability Measurement

Limit

The frequency tolerance of the carrier signal shall be maintained within +/- 0.01% (100ppm) of the operating frequency over a temperature variation of -20 degrees to +50 degrees C at normal supply voltage, and for a variation in the primary supply voltage from 85% to 115% of the rated supply voltage at a temperature of 20 degrees C. For battery operated equipment, the equipment tests shall be performed using a new battery.

Test Procedures

1. The transmitter output (antenna port) was connected to the spectrum analyzer.
2. EUT have transmitted signal and fixed channelize.
3. Set the spectrum analyzer span to view the entire emissions bandwidth.
4. Set RBW = 1 kHz, VBW = 3 kHz with peak detector and maxhold settings.
5. The f_c is declaring of channel frequency. Then the frequency error formula is $(f_c - f) / f_c \times 10^6$ ppm and the limit is less than ± 100 ppm.
6. Extreme temperature rule is -20°C~50°C.

4. RADIATED TEST ITEMS

4.1 Measuring Instruments

See list of measuring instruments of this test report.

4.2 Test Setup

For radiated emissions below 30MHz

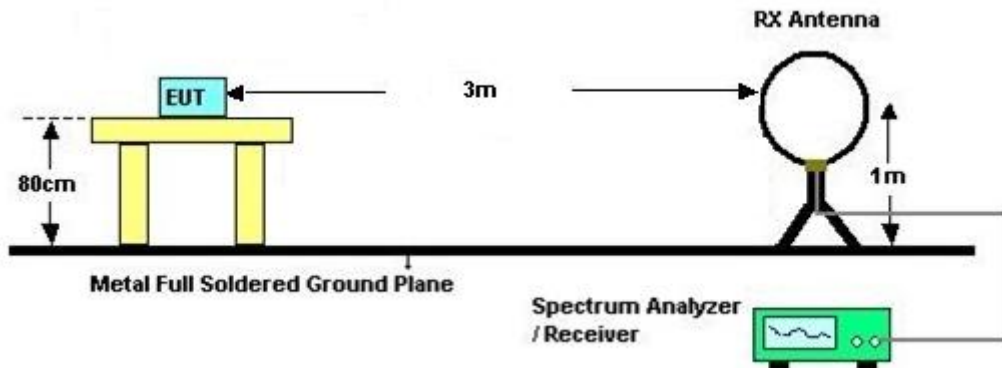

For radiated emissions above 30MHz

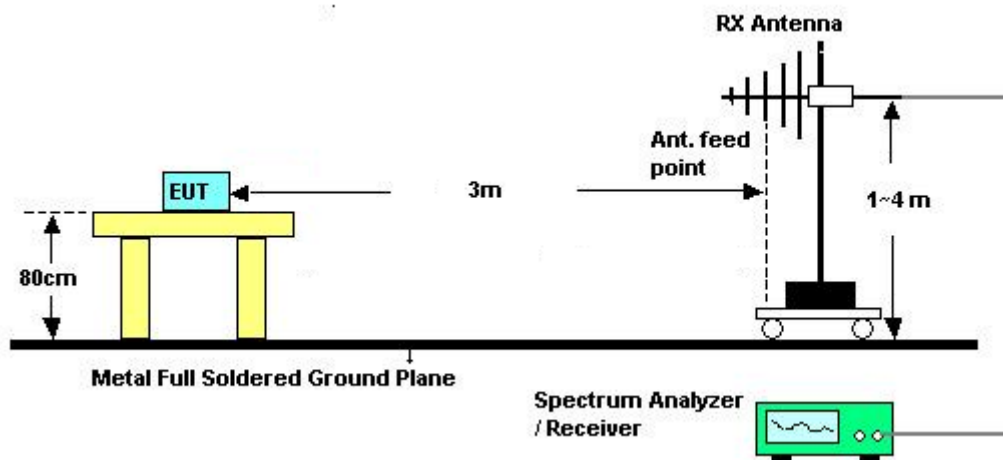

4.3 Test Result of Radiated Test Items

Please refer to Appendix C.



4.4 Field Strength of Fundamental Emissions and Mask Measurement

Limit

Rules and specifications	CFR 47 Part 15 section 15.225(a)-(d)			
Description	Compliance with the spectrum mask is tested using a spectrum analyzer with RBW set to a 9kHz for the band 13.553~13.567MHz			
Freq. of Emission (MHz)	Field Strength (µV/m) at 30m	Field Strength (dBµV/m) at 30m	Field Strength (dBµV/m) at 10m	Field Strength (dBµV/m) at 3m
1.705~13.110	30	29.5	48.58	69.5
13.110~13.410	106	40.5	59.58	80.5
13.410~13.553	334	50.5	69.58	90.5
13.553~13.567	15848	84.0	103.08	124.0
13.567~13.710	334	50.5	69.58	90.5
13.710~14.010	106	40.5	59.58	80.5
14.010~30.000	30	29.5	48.58	69.5

Test Procedures

1. Configure the EUT according to ANSI C63.4. The EUT was placed on the top of the turntable 0.8 meter above ground. The phase center of the loop receiving antenna mounted antenna tower was placed 3 meters far away from the turntable.
2. Power on the EUT and all the supporting units. The turntable was rotated by 360 degrees to determine the position of the highest radiation.
3. The height of the receiving antenna was fixed at one meter above ground to find the maximum emissions field strength.
4. For Fundamental emissions, use the receiver to measure QP reading.
5. When the radiated emissions limits are expressed in terms of the average value of the emissions, and pulsed operation is employed, the measurement field strength shall be determined by averaging over one complete pulse train, including blanking intervals, as long as the pulse train does not exceed 0.1 seconds. As an alternative (provided the transmitter operates for longer than 0.1 seconds) or in cases where the pulse train exceeds 0.1 seconds, the measured field strength shall be determined from the average absolute voltage during a 0.1 second interval during which the field strength is at its maximum value.
6. Compliance with the spectrum mask is tested using a spectrum analyzer with RBW set to a 9kHz for the band 13.553~13.567MHz.

Note: Emission level (dBµV/m) = 20 log Emission level (µV/m).



4.5 Radiated Emissions Measurement

Limit

The field strength of any emissions which appear outside of 13.553~13.567MHz band shall not exceed the general radiated emissions limits.

Frequencies (MHz)	Field Strength (μV/m)	Measurement Distance (meters)
0.009~0.490	2400/F(kHz)	300
0.490~1.705	24000/F(kHz)	30
1.705~30.0	30	30
30~88	100	3
88~216	150	3
216~960	200	3
Above 960	500	3

Measuring Instrument Setting

The following table is the setting of receiver.

Receiver Parameter	Setting
Attenuation	Auto
Frequency Range: 9kHz~150kHz	RBW 200Hz for QP
Frequency Range: 150kHz~30MHz	RBW 9kHz for QP
Frequency Range: 30MHz~1000MHz	RBW 120kHz for Peak

Note: The emission limits shown in the above table are based on measurements employing a CISPR quasi-peak detector except for the frequency bands 9-90 kHz, 110-490 kHz. Radiated emission limits in these two bands are based on measurements employing an average detector.

**Test Procedures**

1. Configure the EUT according to ANSI C63.4. The EUT was placed on the top of the turntable 0.8 meter above ground. The phase center of the receiving antenna mounted on the top of a height-variable antenna tower was placed 3 meters far away from the turntable.
2. Power on the EUT and all the supporting units. The turntable was rotated by 360 degrees to determine the position of the highest radiation.
3. The height of the broadband receiving antenna was varied between one meter and four meters above ground to find the maximum emissions field strength of both horizontal and vertical polarization.
4. For each suspected emissions, the antenna tower was scan (from 1 M to 4 M) and then the turntable was rotated (from 0 degree to 360 degrees) to find the maximum reading.
5. Set the test-receiver system to Peak or CISPR quasi-peak Detect Function with specified bandwidth under Maximum Hold Mode.
6. When the radiated emissions limits are expressed in terms of the average value of the emissions, and pulsed operation is employed, the measurement field strength shall be determined by averaging over one complete pulse train, including blanking intervals, as long as the pulse train does not exceed 0.1 seconds. As an alternative (provided the transmitter operates for longer than 0.1 seconds) or in cases where the pulse train exceeds 0.1 seconds, the measured field strength shall be determined from the average absolute voltage during a 0.1 second interval during which the field strength is at its maximum value.
7. In case the emission is lower than 30MHz, loop antenna has to be used for measurement and the recorded data should be QP measured by receiver. Antenna Requirements

Limit

Except for special regulations, the Low-power Radio-frequency Devices must not be equipped with any jacket for installing an antenna with extension cable. An intentional radiator shall be designed to ensure that no antenna other than that furnished by the responsible party shall be used with the device. The use of a permanently attached antenna or of an antenna that uses a unique coupling to the intentional radiator shall be considered sufficient to comply with the provisions of this Section. The manufacturer may design the unit so that the user can replace a broken antenna, but the use of a standard antenna jack or electrical connector is prohibited.

Antenna Anti-Replacement Construction

An embedded-in antenna design is used.



5. LIST OF MEASURING EQUIPMENT

Instrument	Manufacturer	Model No.	Serial No.	Characteristics	Calibration Date	Test Date	Due Date	Remark
Spectrum Analyzer	Rohde & Schwarz	FSP40	100055	9kHz~40GHz	Jun. 09, 2014	Jan. 02, 2015	Jun. 08, 2015	Conducted (TH02-HY)
Thermal Chamber	Ten Billion	TTH-D3SP	TBN-930701	N/A	Jul. 16, 2014	Jan. 02, 2015	Jul. 15, 2015	Conducted (TH02-HY)
Hygrometer	Testo	608-H1	34897199	N/A	May. 06, 2014	Jan. 02, 2015	May. 05, 2015	Conducted (TH02-HY)
RF cable	WOKEN	S05	S05-130708-038	N/A	Jan. 22, 2014	Jan. 02, 2015	Jan. 21, 2015	Conducted (TH02-HY)
EMI Test Receiver	Rohde & Schwarz	ESCS 30	100356	9kHz ~ 2.75GHz	Dec. 01, 2014	Jan. 06, 2015	Nov. 30, 2015	Conduction (CO05-HY)
LISN	Rohde & Schwarz	ENV216	100080	9kHz ~ 30MHz	Dec. 02, 2014	Jan. 06, 2015	Dec. 01, 2015	Conduction (CO05-HY)
AC Power Source	ChainTek	APC-1000W	N/A	N/A	N/A	Jan. 06, 2015	N/A	Conduction (CO05-HY)
Hygrometer	Testo	608-H1	34913912	N/A	Apr. 23, 2014	Jan. 06, 2015	Apr. 22, 2015	Conduction (CO05-HY)
LF Cable	Shuner	RG-402	N/A	N/A	Oct. 07, 2014	Jan. 06, 2015	Oct. 06, 2015	Conduction (CO05-HY)
Test Software	N/A	EMC32	8.40.0	N/A	N/A	Jan. 06, 2015	N/A	Conduction (CO05-HY)
Preamplifier	COM-POWER	PA-103A	161241	10MHz-1000MHz	Mar. 17, 2014	Jan. 06, 2015	Mar. 16, 2015	Radiation (03CH07-HY)
Bilog Antenna	Schaffner	CBL6111C	2726	30MHz ~ 1GHz	Sep. 27, 2014	Jan. 05, 2015	Sep. 26, 2015	Radiation (03CH07-HY)
Loop Antenna	Rohde & Schwarz	HFH2-Z2	100315	9 kHz~30 MHz	Jul. 28, 2014	Jan. 05, 2015	Jul. 27, 2015	Radiation (03CH07-HY)
EMI Test Receiver	Rohde & Schwarz	ESCI 7	100724	9kHz~7GHz	Aug. 30, 2014	Jan. 05, 2015	Aug. 29, 2015	Radiation (03CH07-HY)
Signal Analyzer	Rohde & Schwarz	FSV 30	101749	10Hz~30GHz	Feb. 10, 2014	Jan. 05, 2015	Feb. 09, 2015	Radiation (03CH07-HY)
Controller	ChainTek	Chaintek 3000	N/A	Control Turn table	N/A	Jan. 05, 2015	N/A	Radiation (03CH07-HY)
Controller	Max-Full	MF7802	MF780208368	Control Ant Mast	N/A	Jan. 05, 2015	N/A	Radiation (03CH07-HY)
Turn Table	ChainTek	Chaintek 3000	N/A	0~360 degree	N/A	Jan. 05, 2015	N/A	Radiation (03CH07-HY)
Antenna Mast	Max-Full	MFA520BS	N/A	1m~4m	N/A	Jan. 05, 2015	N/A	Radiation (03CH07-HY)
Hygrometer	Testo	608-H1	34897197	N/A	May. 06, 2014	Jan. 05, 2015	May. 05, 2015	Radiation (03CH07-HY)
RF Cable	HUBER + SUHNER	SUCOFLEX 104	MY84209521	9KHz~1GHz	Dec. 04, 2014	Jan. 05, 2015	Dec. 03, 2015	Radiation (03CH07-HY)
Filter	Wainwright	WHK20 /1000C7/40S S	SN2	20M High Pass	Oct. 01, 2014	Jan. 05, 2015	Sep. 30, 2015	Radiation (03CH07-HY)
Test Software	N/A	E3	6.2009-8-24 (sporton)	N/A	N/A	Jan. 05, 2015	N/A	Radiation (03CH07-HY)

Note: Test equipment calibration is traceable to the procedure of ISO17025.



Appendix A. Test Results of Conducted Emission Test

Test Mode :	NFC Tx	Test Voltage :	120Vac / 60Hz
Function Type :	GSM850 Idle + Bluetooth Link + WLAN Link + USB Cable (Charging from Adapter) + NFC Tx + Earphone		

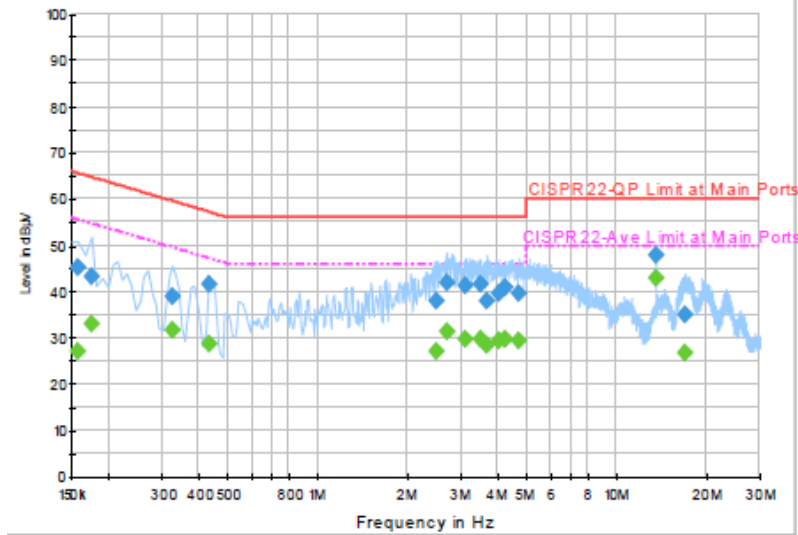

Final Result : Quasi-Peak

Frequency (MHz)	Quasi-Peak (dBµV)	Filter	Line	Corr. (dB)	Margin (dB)	Limit (dBµV)
0.158000	45.3	Off	L1	19.4	20.3	65.6
0.174000	43.3	Off	L1	19.4	21.5	64.8
0.326000	39.0	Off	L1	19.5	20.6	59.6
0.430000	41.6	Off	L1	19.5	15.7	57.3
2.486000	37.8	Off	L1	19.6	18.2	56.0
2.686000	42.1	Off	L1	19.7	13.9	56.0
3.118000	41.4	Off	L1	19.6	14.6	56.0
3.478000	41.6	Off	L1	19.6	14.4	56.0
3.670000	37.9	Off	L1	19.6	18.1	56.0
4.014000	39.5	Off	L1	19.7	16.5	56.0
4.230000	40.9	Off	L1	19.7	15.1	56.0
4.670000	39.7	Off	L1	19.7	16.3	56.0
13.558000	48.0	Off	L1	19.9	12.0	60.0
16.934000	35.1	Off	L1	19.9	24.9	60.0



Test Mode :	NFC Tx	Test Voltage :	120Vac / 60Hz
Function Type :	GSM850 Idle + Bluetooth Link + WLAN Link + USB Cable (Charging from Adapter) + NFC Tx + Earphone		

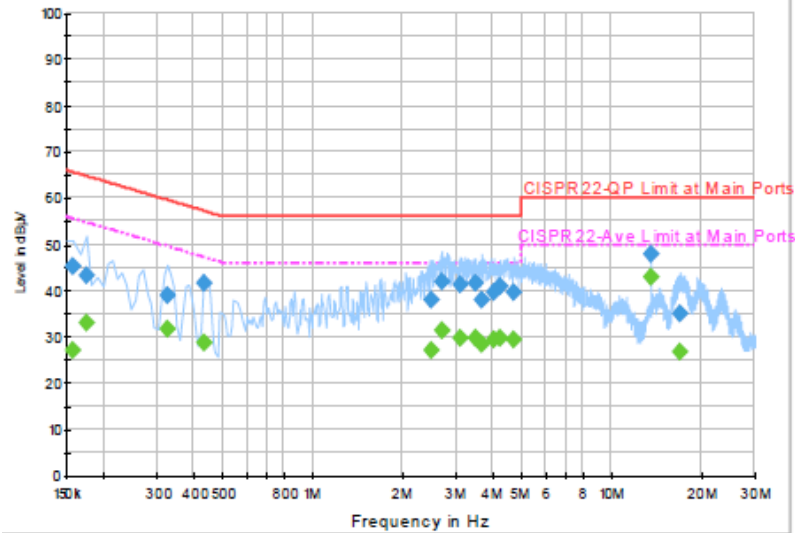

Final Result : Average

Frequency (MHz)	Average (dBµV)	Filter	Line	Corr. (dB)	Margin (dB)	Limit (dBµV)
0.158000	26.9	Off	L1	19.4	28.7	55.6
0.174000	32.9	Off	L1	19.4	21.9	54.8
0.326000	31.8	Off	L1	19.5	17.8	49.6
0.430000	28.7	Off	L1	19.5	18.6	47.3
2.486000	27.2	Off	L1	19.6	18.8	46.0
2.686000	31.4	Off	L1	19.7	14.6	46.0
3.118000	29.8	Off	L1	19.6	16.2	46.0
3.478000	29.8	Off	L1	19.6	16.2	46.0
3.670000	28.3	Off	L1	19.6	17.7	46.0
4.014000	29.5	Off	L1	19.7	16.5	46.0
4.230000	29.7	Off	L1	19.7	16.3	46.0
4.670000	29.4	Off	L1	19.7	16.6	46.0
13.558000	43.0	Off	L1	19.9	7.0	50.0
16.934000	26.7	Off	L1	19.9	23.3	50.0



Test Mode :	NFC Tx	Test Voltage :	120Vac / 60Hz
Function Type :	GSM850 Idle + Bluetooth Link + WLAN Link + USB Cable (Charging from Adapter) + NFC Tx + Earphone		

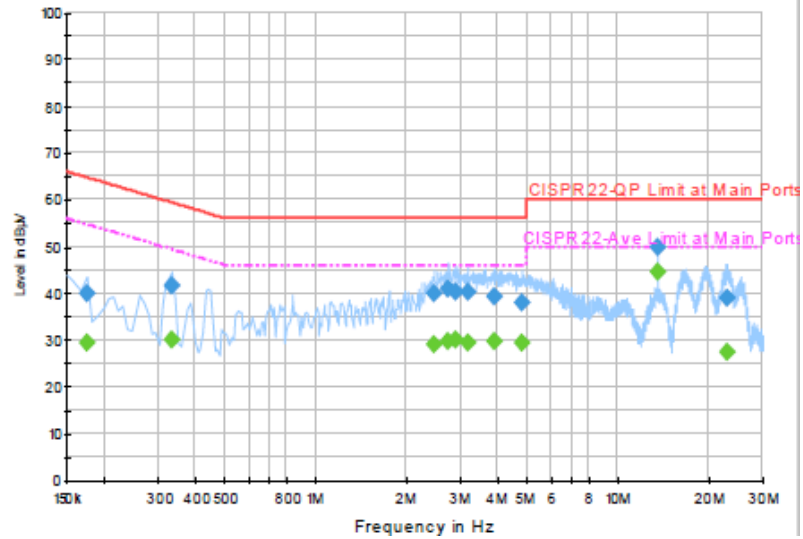

Final Result : Quasi-Peak

Frequency (MHz)	Quasi-Peak (dBµV)	Filter	Line	Corr. (dB)	Margin (dB)	Limit (dBµV)
0.174000	40.0	Off	N	19.4	24.8	64.8
0.334000	41.5	Off	N	19.4	17.9	59.4
2.462000	40.0	Off	N	19.6	16.0	56.0
2.742000	40.8	Off	N	19.6	15.2	56.0
2.910000	40.3	Off	N	19.6	15.7	56.0
3.190000	40.1	Off	N	19.6	15.9	56.0
3.862000	39.4	Off	N	19.7	16.6	56.0
4.814000	38.0	Off	N	19.7	18.0	56.0
13.558000	49.9	Off	N	19.9	10.1	60.0
22.950000	39.0	Off	N	20.0	21.0	60.0



Test Mode :	NFC Tx	Test Voltage :	120Vac / 60Hz
Function Type :	GSM850 Idle + Bluetooth Link + WLAN Link + USB Cable (Charging from Adapter) + NFC Tx + Earphone		

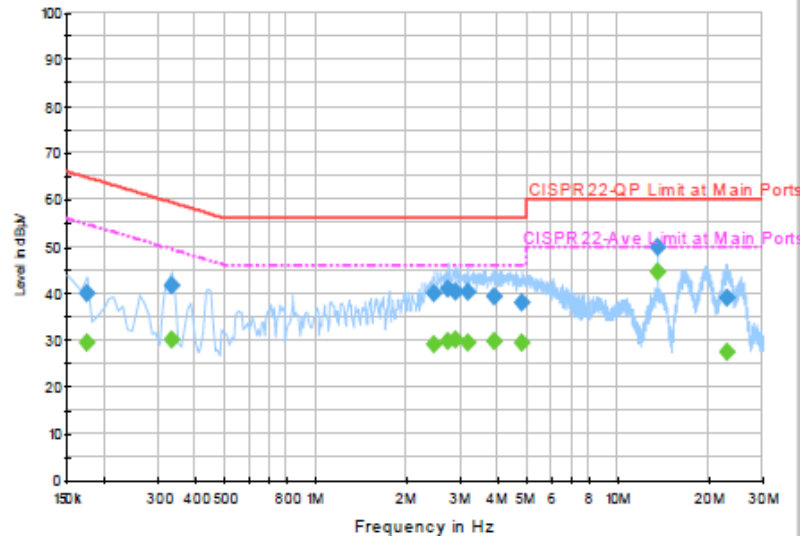

Final Result : Average

Frequency (MHz)	Average (dBµV)	Filter	Line	Corr. (dB)	Margin (dB)	Limit (dBµV)
0.174000	29.4	Off	N	19.4	25.4	54.8
0.334000	30.1	Off	N	19.4	19.3	49.4
2.462000	29.2	Off	N	19.6	16.8	46.0
2.742000	29.8	Off	N	19.6	16.2	46.0
2.910000	29.9	Off	N	19.6	16.1	46.0
3.190000	29.4	Off	N	19.6	16.6	46.0
3.862000	29.7	Off	N	19.7	16.3	46.0
4.814000	29.2	Off	N	19.7	16.8	46.0
13.558000	44.5	Off	N	19.9	5.5	50.0
22.950000	27.4	Off	N	20.0	22.6	50.0

Remark: 13.558MHz is the NFC RF fundamental signal.



Appendix B. Test Results of Conducted Test Items

B.1 Test Result of 20dB Spectrum Bandwidth

Test mode	NFC Tx	Test Frequency (MHz)	13.56
20dB Bandwidth (kHz)	2.640	99% OccupiedBW(kHz)	2.240
Frequency range (MHz)	$f_L > 13.553$	13.55900	Test Result
	$f_H < 13.567$	13.56164	Complies



B.2 Test Result of Frequency Stability

Voltage vs. Frequency Stability		Temperature vs. Frequency Stability	
Voltage (Vac)	Measurement Frequency (MHz)	Temperature (°C)	Measurement Frequency (MHz)
120	13.560320	-20	13.560440
102	13.560320	-10	13.560410
138	13.560320	0	13.560400
		10	13.560380
		20	13.560350
		30	13.560330
		40	13.560290
		50	13.560270
Max.Deviation (MHz)	0.000320	Max.Deviation (MHz)	0.000440
Max.Deviation (ppm)	23.5988	Max.Deviation (ppm)	32.4484
Limit	FS < ±100 ppm	Limit	FS < ±100 ppm
Test Result	PASS	Test Result	PASS



Appendix C. Test Results of Radiated Test Items

C.1 Test Result of Field Strength of Fundamental Emissions

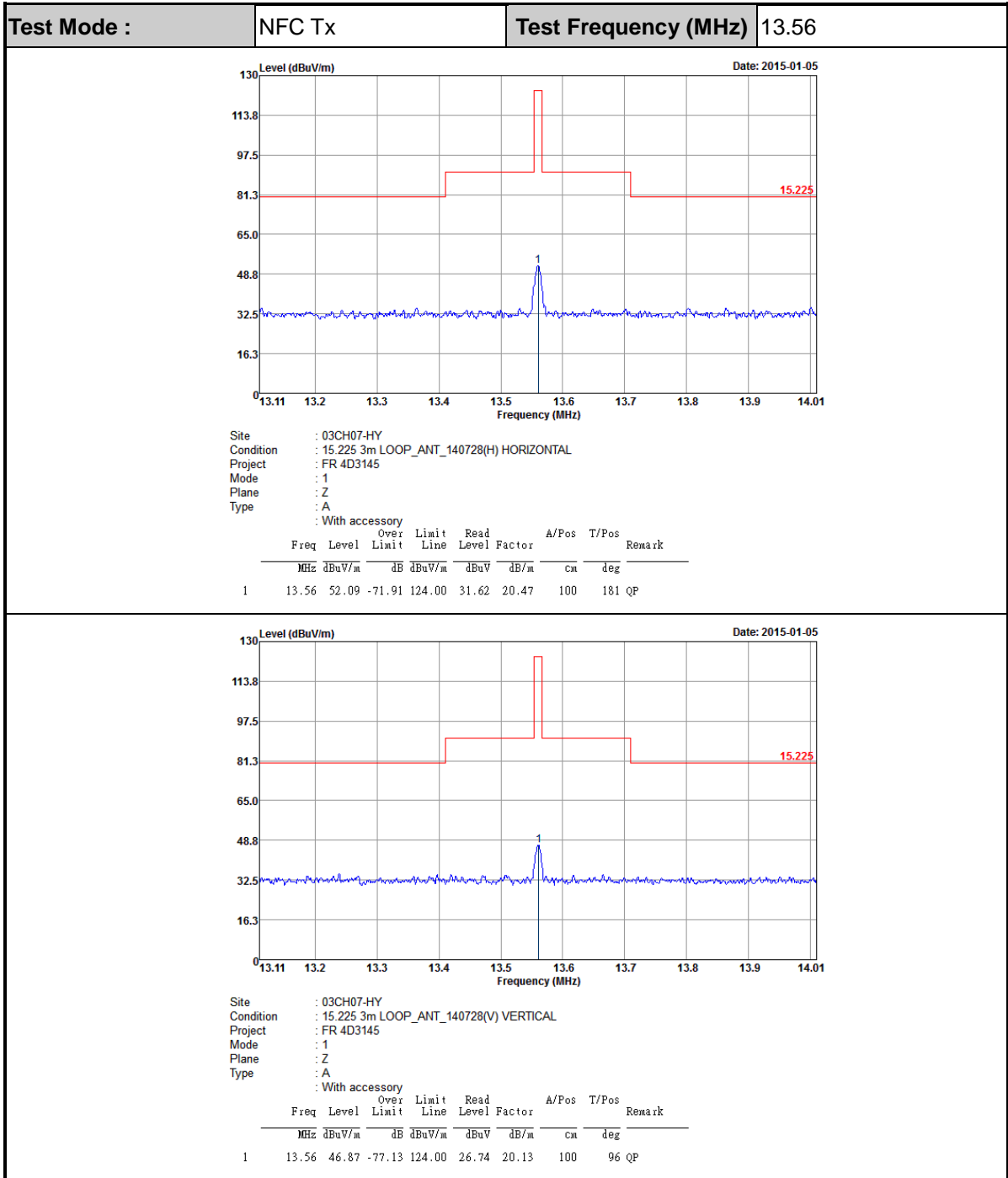

Note: All NFC's spurious emissions are below 20dB of limits.



C.2 Results of Radiated Emissions (9 kHz~30MHz)

Test Mode :		NFC Tx			Polarization :		Horizontal		
Frequency (MHz)	Level (dBμV/m)	Over Limit (dB)	Limit Line (dBμV/m)	Read Level (dBμV)	Antenna Factor (dB)	Cable Loss (dB)	Ant Pos (cm)	Table Pos (deg)	Remark
0.05704	37.05	-75.43	112.48	16.75	20.01	0.29	-	-	Average
0.06063	22.55	-89.4	111.95	2.25	20.01	0.29	-	-	Average
0.09668	21.21	-86.69	107.9	0.96	19.96	0.29	-	-	QP
0.11408	27.41	-79.05	106.46	7.18	19.94	0.29	-	-	Average
0.23092	40.73	-59.6	100.33	20.54	19.9	0.29	-	-	Average
0.49	40.5	-33.3	73.8	20.33	19.88	0.29	-	-	QP
10.88	34.09	-35.91	70	13.65	20.05	0.39	-	-	QP
13.56	48.74	-	-	28.27	20.07	0.4	-	-	QP
21.139	34.38	-35.62	70	13.41	20.54	0.43	-	-	QP
28.35	34.87	-35.13	70	13.74	20.63	0.5	100	102	QP



Test Mode :	NFC Tx			Polarization :	Vertical				
Frequency (MHz)	Level (dB μ V/m)	Over Limit (dB)	Limit Line (dB μ V/m)	Read Level (dB μ V)	Antenna Factor (dB)	Cable Loss (dB)	Ant Pos (cm)	Table Pos (deg)	Remark
0.05704	32.62	-79.86	112.48	12.3	20.03	0.29	-	-	Average
0.07008	22.17	-88.52	110.69	1.85	20.03	0.29	-	-	Average
0.09456	21.78	-86.31	108.09	1.5	19.99	0.29	-	-	QP
0.11404	25.06	-81.4	106.46	4.81	19.96	0.29	-	-	Average
0.22718	42.16	-58.32	100.48	21.94	19.93	0.29	-	-	Average
0.50502	42.4	-31.14	73.54	22.21	19.9	0.29	100	125	QP
8.928	32.21	-37.79	70	12.02	19.81	0.38	-	-	QP
10.096	32.91	-37.09	70	12.71	19.81	0.39	-	-	QP
13.56	44.21	-	-	24.08	19.73	0.4	-	-	QP
19.492	35.46	-34.54	70	15.15	19.88	0.43	-	-	QP
25.11	36.77	-33.23	70	16.25	20.07	0.45	-	-	QP

Note:

1. 13.56 MHz is fundamental signal which can be ignored.
2. The amplitude of spurious emissions which are attenuated by more than 20dB below the permissible value has no need to be reported.
3. Distance extrapolation factor = $40 \log(\text{specific distance} / \text{test distance})$ (dB);
4. Limit line = specific limits (dB μ V) + distance extrapolation factor.



C.3 Results of Radiated Emissions (30MHz~1GHz)

Test Mode :		NFC Tx			Polarization :		Horizontal			
Frequency (MHz)	Level (dBμV/m)	Over Limit (dB)	Limit Line (dBμV/m)	Read Level (dBμV)	Antenna Factor (dB)	Cable Loss (dB)	Preamp Factor (dB)	Ant Pos (cm)	Table Pos (deg)	Remark
41.61	24.88	-15.12	40	41.71	12.6	1.77	31.2	124	243	Peak
133.68	19.22	-24.28	43.5	36.34	11.6	2.38	31.1	-	-	Peak
241.95	20.99	-25.01	46	37.43	11.6	2.96	31	-	-	Peak
496.7	21.03	-24.97	46	29.93	17.96	3.77	30.63	-	-	Peak
774.6	26.85	-19.15	46	30.67	22.05	4.48	30.35	-	-	Peak
968.5	29.87	-24.13	54	30.47	24.79	4.94	30.33	-	-	Peak

Test Mode :		NFC Tx			Polarization :		Vertical			
Frequency (MHz)	Level (dBμV/m)	Over Limit (dB)	Limit Line (dBμV/m)	Read Level (dBμV)	Antenna Factor (dB)	Cable Loss (dB)	Preamp Factor (dB)	Ant Pos (cm)	Table Pos (deg)	Remark
111.81	24.42	-19.08	43.5	42.31	10.91	2.38	31.18	-	-	Peak
153.66	33.89	-9.61	43.5	51.68	10.74	2.61	31.14	136	278	Peak
272.46	17.77	-28.23	46	32.71	12.87	3.16	30.97	-	-	Peak
550.6	22.77	-23.23	46	29.74	19.82	4.01	30.8	-	-	Peak
727.7	25.75	-20.25	46	29.9	21.84	4.41	30.4	-	-	Peak
932.8	29.38	-16.62	46	30.65	24.3	4.8	30.37	-	-	Peak

Note:

1. The amplitude of spurious emissions which are attenuated by more than 20dB below the permissible value has no need to be reported.
2. Emission level (dBμV/m) = 20 log Emission level (μV/m).
3. Corrected Reading: Antenna Factor + Cable Loss + Read Level - Preamp Factor= Level.