

System Check_Head_835MHz_150211

DUT: D835V2-4d162

Communication System: CW; Frequency: 835 MHz; Duty Cycle: 1:1

Medium: HSL_850_150211 Medium parameters used: $f = 835 \text{ MHz}$; $\sigma = 0.881 \text{ S/m}$; $\epsilon_r = 42.165$; $\rho = 1000 \text{ kg/m}^3$

Ambient Temperature : $23.5 \text{ }^\circ\text{C}$; Liquid Temperature : $22.5 \text{ }^\circ\text{C}$

DASY5 Configuration:

- Probe: EX3DV4 - SN3955; ConvF(10.04, 10.04, 10.04); Calibrated: 2014/11/21;
- Sensor-Surface: 1.4mm (Mechanical Surface Detection)
- Electronics: DAE4 Sn1399; Calibrated: 2014/11/13
- Phantom: SAM-Left; Type: QD 000 P40 C; Serial: TP-1478
- Measurement SW: DASY52, Version 52.8 (8); SEMCAD X Version 14.6.10 (7331)

Configuration/Pin=250mW/Area Scan (61x61x1): Interpolated grid: $dx=1.500 \text{ mm}$, $dy=1.500 \text{ mm}$

Maximum value of SAR (interpolated) = 2.85 W/kg

Configuration/Pin=250mW/Zoom Scan (5x5x7)/Cube 0: Measurement grid: $dx=8\text{mm}$, $dy=8\text{mm}$, $dz=5\text{mm}$

Reference Value = 58.18 V/m ; Power Drift = -0.06 dB

Peak SAR (extrapolated) = 3.36 W/kg

SAR(1 g) = 2.25 W/kg ; SAR(10 g) = 1.47 W/kg

Maximum value of SAR (measured) = 2.85 W/kg

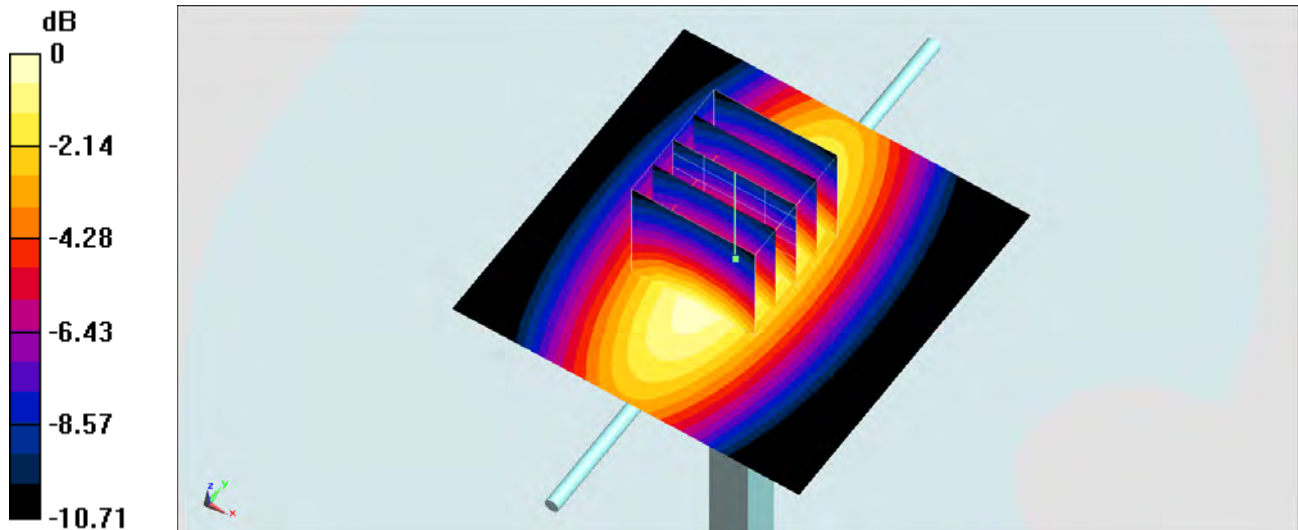

0 dB = $2.85 \text{ W/kg} = 4.55 \text{ dBW/kg}$

System Check_Head_835MHz_150213

DUT: D835V2-4d162

Communication System: CW; Frequency: 835 MHz; Duty Cycle: 1:1

Medium: HSL_850_150213 Medium parameters used: $f = 835 \text{ MHz}$; $\sigma = 0.925 \text{ S/m}$; $\epsilon_r = 43.289$; $\rho = 1000 \text{ kg/m}^3$

Ambient Temperature : $23.3 \text{ }^\circ\text{C}$; Liquid Temperature : $22.3 \text{ }^\circ\text{C}$

DASY5 Configuration:

- Probe: EX3DV4 - SN3697; ConvF(8.93, 8.93, 8.93); Calibrated: 2014/9/29;
- Sensor-Surface: 1.4mm (Mechanical Surface Detection)
- Electronics: DAE4 Sn1388; Calibrated: 2014/9/24
- Phantom: SAM-Left; Type: QD 000 P40 C; Serial: TP-1478
- Measurement SW: DASY52, Version 52.8 (8); SEMCAD X Version 14.6.10 (7331)

Configuration/Pin=250mW/Area Scan (61x61x1): Interpolated grid: $dx=1.500 \text{ mm}$, $dy=1.500 \text{ mm}$

Maximum value of SAR (interpolated) = 2.84 W/kg

Configuration/Pin=250mW/Zoom Scan (5x5x7)/Cube 0: Measurement grid: $dx=8\text{mm}$, $dy=8\text{mm}$, $dz=5\text{mm}$

Reference Value = 56.26 V/m ; Power Drift = -0.09 dB

Peak SAR (extrapolated) = 3.31 W/kg

SAR(1 g) = 2.24 W/kg ; SAR(10 g) = 1.47 W/kg

Maximum value of SAR (measured) = 2.82 W/kg

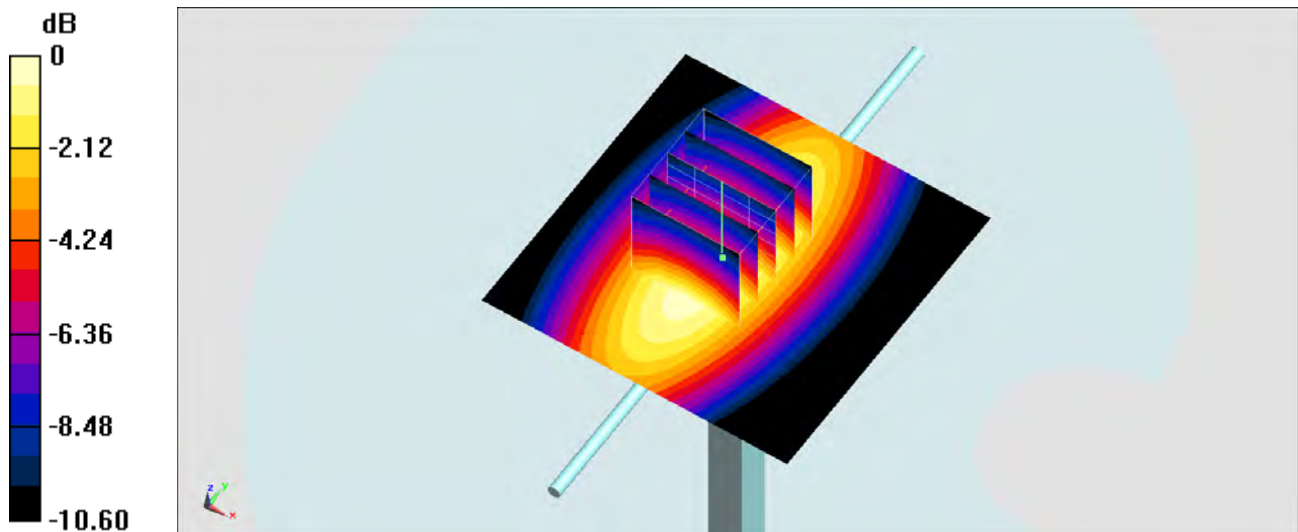

0 dB = $2.82 \text{ W/kg} = 4.50 \text{ dBW/kg}$

System Check_Head_835MHz_150215

DUT: D835V2-4d162

Communication System: CW; Frequency: 835 MHz; Duty Cycle: 1:1

Medium: HSL_850_150215 Medium parameters used: $f = 835 \text{ MHz}$; $\sigma = 0.929 \text{ S/m}$; $\epsilon_r = 43.117$; $\rho = 1000 \text{ kg/m}^3$

Ambient Temperature : $23.4 \text{ }^\circ\text{C}$; Liquid Temperature : $22.4 \text{ }^\circ\text{C}$

DASY5 Configuration:

- Probe: EX3DV4 - SN3931; ConvF(10.32, 10.32, 10.32); Calibrated: 2014/9/25;
- Sensor-Surface: 1.4mm (Mechanical Surface Detection)
- Electronics: DAE3 Sn577; Calibrated: 2014/10/6
- Phantom: SAM-Right; Type: QD 000 P40 C; Serial: TP-1446
- Measurement SW: DASY52, Version 52.8 (8); SEMCAD X Version 14.6.10 (7331)

Configuration/Pin=250mW/Area Scan (61x61x1): Interpolated grid: $dx=1.500 \text{ mm}$, $dy=1.500 \text{ mm}$

Maximum value of SAR (interpolated) = 3.23 W/kg

Configuration/Pin=250mW/Zoom Scan (5x5x7)/Cube 0: Measurement grid: $dx=8\text{mm}$, $dy=8\text{mm}$, $dz=5\text{mm}$

Reference Value = 61.44 V/m ; Power Drift = -0.13 dB

Peak SAR (extrapolated) = 3.70 W/kg

SAR(1 g) = 2.4 W/kg ; SAR(10 g) = 1.58 W/kg

Maximum value of SAR (measured) = 3.22 W/kg

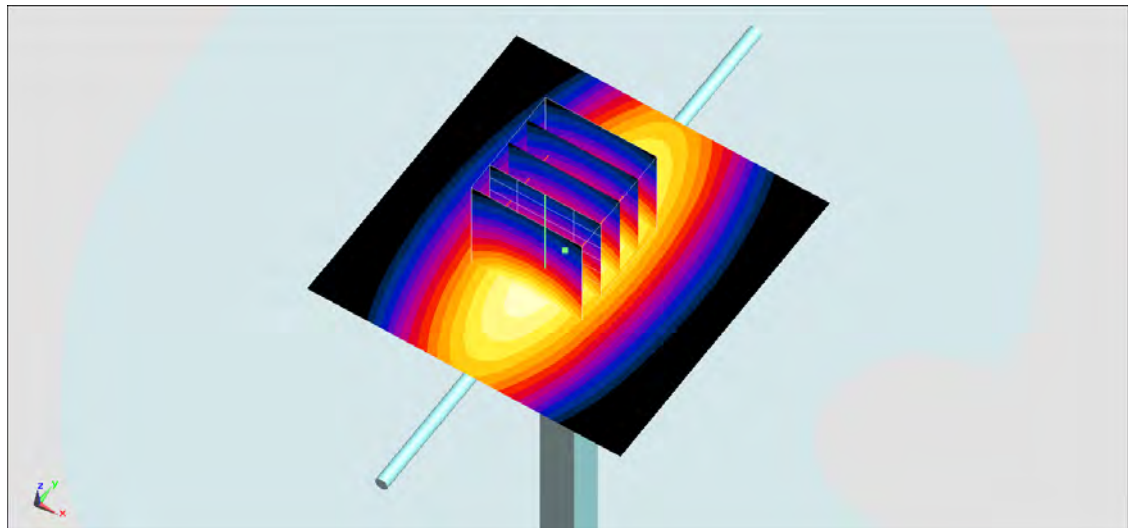
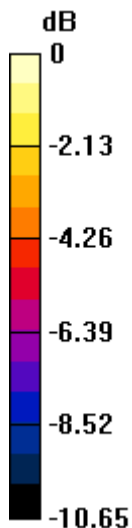

0 dB = 3.22 W/kg = 5.08 dBW/kg

System Check_Body_835MHz_150213

DUT: D835V2-4d162

Communication System: CW ; Frequency: 835 MHz;Duty Cycle: 1:1

Medium: MSL_850_150213 Medium parameters used: $f = 835 \text{ MHz}$; $\sigma = 0.981 \text{ S/m}$; $\epsilon_r = 54.961$; $\rho = 1000 \text{ kg/m}^3$

Ambient Temperature : $23.5 \text{ }^\circ\text{C}$; Liquid Temperature : $22.5 \text{ }^\circ\text{C}$

DASY5 Configuration:

- Probe: EX3DV4 - SN3697; ConvF(8.75, 8.75, 8.75); Calibrated: 2014/9/29;
- Sensor-Surface: 1.4mm (Mechanical Surface Detection)
- Electronics: DAE4 Sn1388; Calibrated: 2014/9/24
- Phantom: SAM-Right; Type: QD 000 P40 C; Serial: TP-1446
- Measurement SW: DASY52, Version 52.8 (8);SEMCAD X Version 14.6.10 (7331)

Configuration/Pin=250mW/Area Scan (61x61x1): Interpolated grid: $dx=1.500 \text{ mm}$, $dy=1.500 \text{ mm}$

Maximum value of SAR (interpolated) = 3.17 W/kg

Configuration/Pin=250mW/Zoom Scan (5x5x7)/Cube 0: Measurement grid: $dx=8\text{mm}$, $dy=8\text{mm}$, $dz=5\text{mm}$

Reference Value = 58.98 V/m ; Power Drift = -0.14 dB

Peak SAR (extrapolated) = 3.67 W/kg

SAR(1 g) = 2.47 W/kg ; SAR(10 g) = 1.63 W/kg

Maximum value of SAR (measured) = 3.10 W/kg

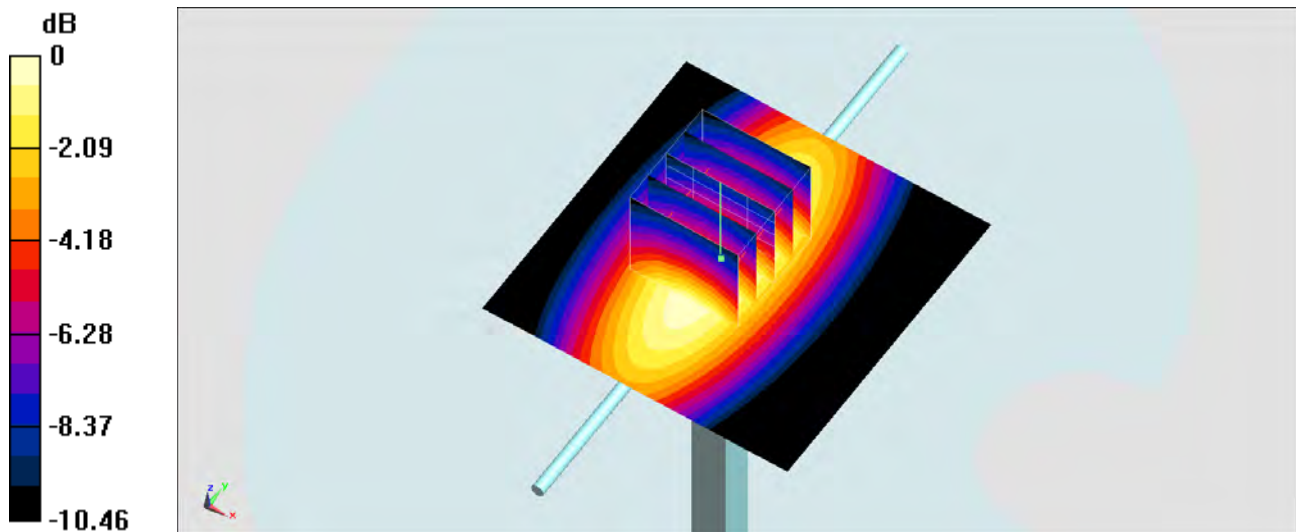

0 dB = $3.10 \text{ W/kg} = 4.91 \text{ dBW/kg}$

System Check_Body_835MHz_150214

DUT: D835V2-4d162

Communication System: CW ; Frequency: 835 MHz;Duty Cycle: 1:1

Medium: MSL_850_150214 Medium parameters used: $f = 835 \text{ MHz}$; $\sigma = 0.972 \text{ S/m}$; $\epsilon_r = 54.215$; $\rho = 1000 \text{ kg/m}^3$

Ambient Temperature : $23.4 \text{ }^\circ\text{C}$; Liquid Temperature : $22.4 \text{ }^\circ\text{C}$

DASY5 Configuration:

- Probe: EX3DV4 - SN3954; ConvF(10.01, 10.01, 10.01); Calibrated: 2014/11/21;
- Sensor-Surface: 1.4mm (Mechanical Surface Detection)
- Electronics: DAE4 Sn1279; Calibrated: 2014/7/23
- Phantom: SAM-Left; Type: QD 000 P40 C; Serial: TP-1478
- Measurement SW: DASY52, Version 52.8 (8);SEMCAD X Version 14.6.10 (7331)

Configuration/Pin=250mW/Area Scan (61x61x1): Interpolated grid: $dx=1.500 \text{ mm}$, $dy=1.500 \text{ mm}$

Maximum value of SAR (interpolated) = 3.13 W/kg

Configuration/Pin=250mW/Zoom Scan (5x5x7)/Cube 0: Measurement grid: $dx=8\text{mm}$, $dy=8\text{mm}$, $dz=5\text{mm}$

Reference Value = 59.21 V/m ; Power Drift = -0.04 dB

Peak SAR (extrapolated) = 3.53 W/kg

SAR(1 g) = 2.33 W/kg ; SAR(10 g) = 1.54 W/kg

Maximum value of SAR (measured) = 3.10 W/kg

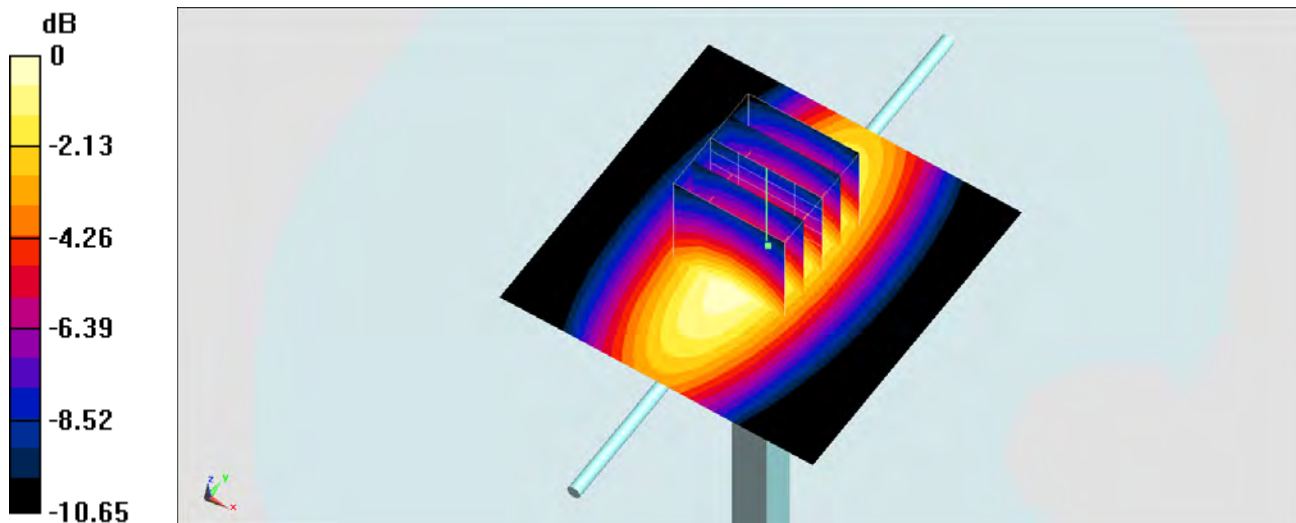

0 dB = 3.10 W/kg = 4.91 dBW/kg

System Check_Head_1900MHz_150208

DUT: D1900V2-5d182

Communication System: CW; Frequency: 1900 MHz; Duty Cycle: 1:1

Medium: HSL_1900_150208 Medium parameters used: $f = 1900$ MHz; $\sigma = 1.432$ S/m; $\epsilon_r = 39.04$; $\rho = 1000$ kg/m³

Ambient Temperature : 23.3 °C; Liquid Temperature : 22.3 °C

DASY5 Configuration:

- Probe: EX3DV4 - SN3925; ConvF(8.26, 8.26, 8.26); Calibrated: 2014/5/22;
- Sensor-Surface: 1.4mm (Mechanical Surface Detection)
- Electronics: DAE3 Sn495; Calibrated: 2014/5/19
- Phantom: SAM_Right; Type: QD000P40CC; Serial: TP:1383
- Measurement SW: DASY52, Version 52.8 (7); SEMCAD X Version 14.6.10 (7164)

Configuration/Pin=250mW/Area Scan (61x61x1): Interpolated grid: dx=1.500 mm, dy=1.500 mm

Maximum value of SAR (interpolated) = 16.9 W/kg

Configuration/Pin=250mW/Zoom Scan (5x5x7)/Cube 0: Measurement grid: dx=8mm, dy=8mm, dz=5mm

Reference Value = 109.5 V/m; Power Drift = -0.00 dB

Peak SAR (extrapolated) = 19.7 W/kg

SAR(1 g) = 10.4 W/kg; SAR(10 g) = 5.31 W/kg

Maximum value of SAR (measured) = 16.1 W/kg

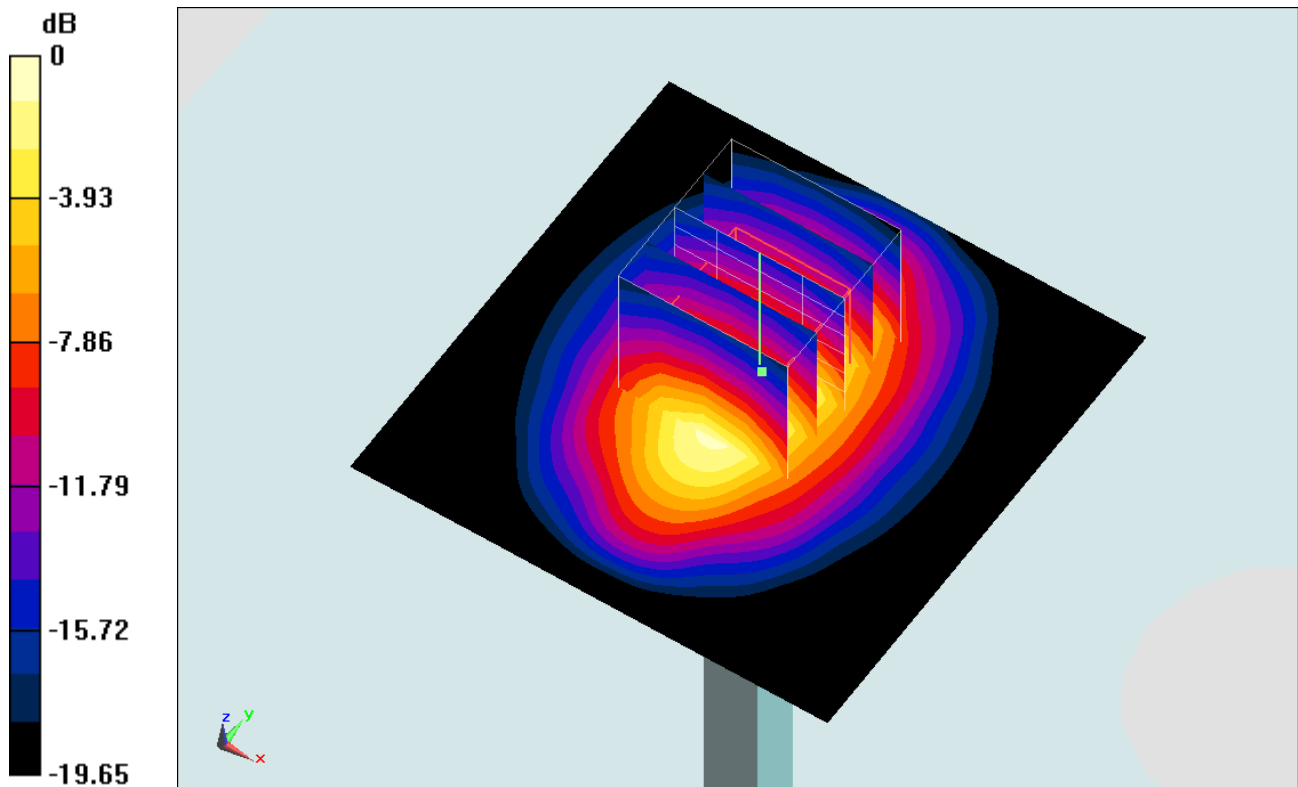

0 dB = 16.1 W/kg = 12.07 dBW/kg

System Check_Body_1900MHz_150205

DUT: D1900V2-5d182

Communication System: CW; Frequency: 1900 MHz; Duty Cycle: 1:1

Medium: MSL_1900_150205 Medium parameters used: $f = 1900 \text{ MHz}$; $\sigma = 1.532 \text{ S/m}$; $\epsilon_r = 52.506$; $\rho = 1000 \text{ kg/m}^3$

Ambient Temperature : $23.6 \text{ }^\circ\text{C}$; Liquid Temperature : $22.6 \text{ }^\circ\text{C}$

DASY5 Configuration:

- Probe: EX3DV4 - SN3925; ConvF(7.87, 7.87, 7.87); Calibrated: 2014/5/22;
- Sensor-Surface: 1.4mm (Mechanical Surface Detection)
- Electronics: DAE3 Sn495; Calibrated: 2014/5/19
- Phantom: SAM_Right; Type: QD000P40CC; Serial: TP:1383
- Measurement SW: DASY52, Version 52.8 (7); SEMCAD X Version 14.6.10 (7164)

Configuration/Pin=250mW/Area Scan (61x61x1): Interpolated grid: $dx=1.500 \text{ mm}$, $dy=1.500 \text{ mm}$

Maximum value of SAR (interpolated) = 13.8 W/kg

Configuration/Pin=250mW/Zoom Scan (5x5x7)/Cube 0: Measurement grid: $dx=8\text{mm}$, $dy=8\text{mm}$, $dz=5\text{mm}$

Reference Value = 97.613 V/m ; Power Drift = 0.05 dB

Peak SAR (extrapolated) = 17.3 W/kg

SAR(1 g) = 9.71 W/kg ; SAR(10 g) = 5.04 W/kg

Maximum value of SAR (measured) = 14.9 W/kg

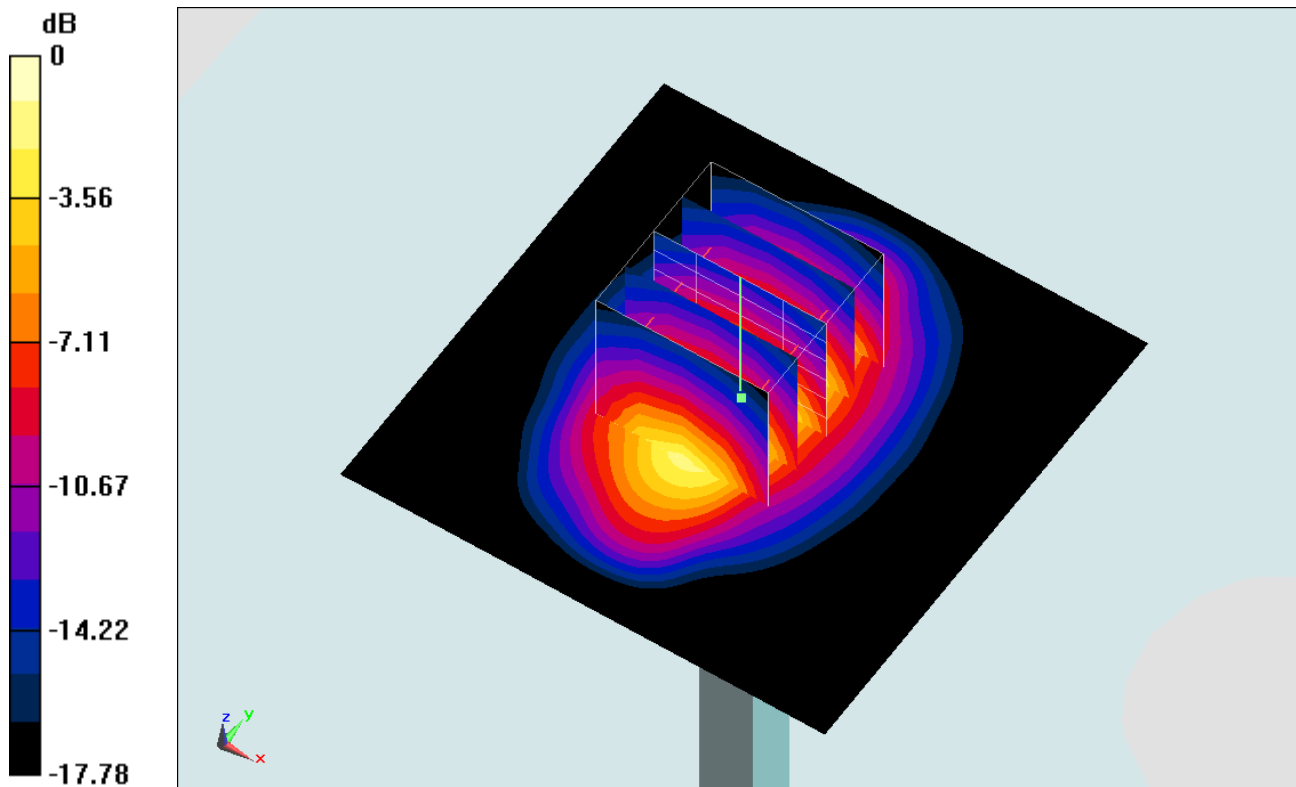

0 dB = 14.9 W/kg = 11.73 dBW/kg

System Check_Body_1900MHz_150209

DUT: D1900V2-5d182

Communication System: CW; Frequency: 1900 MHz; Duty Cycle: 1:1

Medium: MSL_1900_150209 Medium parameters used: $f = 1900$ MHz; $\sigma = 1.535$ S/m; $\epsilon_r = 52.471$; $\rho = 1000$ kg/m³

Ambient Temperature : 23.5 °C ; Liquid Temperature : 22.5 °C

DASY5 Configuration:

- Probe: EX3DV4 - SN3925; ConvF(7.87, 7.87, 7.87); Calibrated: 2014/5/22;
- Sensor-Surface: 1.4mm (Mechanical Surface Detection)
- Electronics: DAE3 Sn495; Calibrated: 2014/5/19
- Phantom: SAM_Left; Type: QD000P40CD; Serial: TP:1542
- Measurement SW: DASY52, Version 52.8 (7); SEMCAD X Version 14.6.10 (7164)

Configuration/Pin=250mW/Area Scan (61x61x1): Interpolated grid: dx=1.500 mm, dy=1.500 mm

Maximum value of SAR (interpolated) = 13.9 W/kg

Configuration/Pin=250mW/Zoom Scan (5x5x7)/Cube 0: Measurement grid: dx=8mm, dy=8mm, dz=5mm

Reference Value = 97.613 V/m; Power Drift = 0.15 dB

Peak SAR (extrapolated) = 17.4 W/kg

SAR(1 g) = 9.73 W/kg; SAR(10 g) = 5.05 W/kg

Maximum value of SAR (measured) = 14.9 W/kg

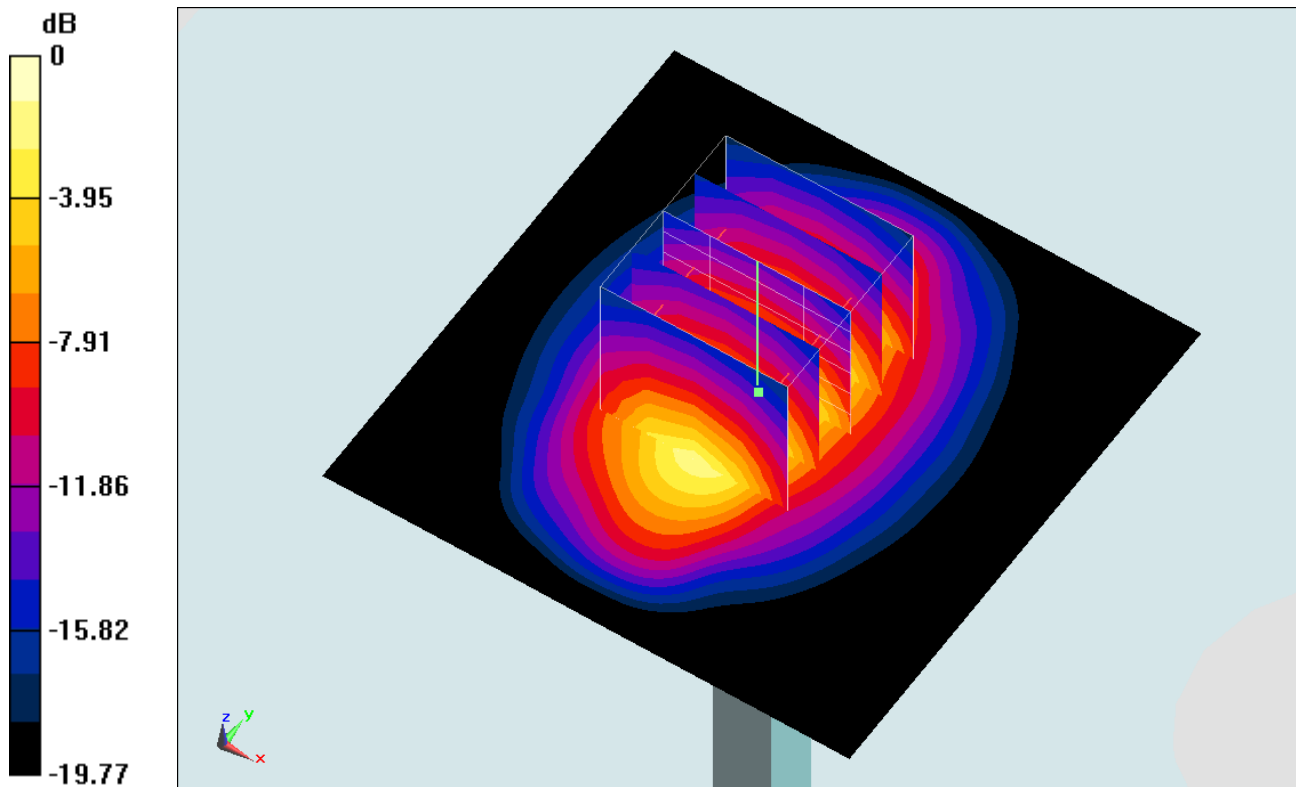

0 dB = 14.9 W/kg = 11.73 dBW/kg

System Check_Head_2450MHz_141223

DUT: D2450V2-924

Communication System: CW; Frequency: 2450 MHz; Duty Cycle: 1:1

Medium: HSL_2450_141223 Medium parameters used: $f = 2450 \text{ MHz}$; $\sigma = 1.84 \text{ mho/m}$; $\epsilon_r = 38.7$; $\rho = 1000 \text{ kg/m}^3$

Ambient Temperature : $23.4 \text{ }^\circ\text{C}$; Liquid Temperature : $22.4 \text{ }^\circ\text{C}$

DASY4 Configuration:

- Probe: ES3DV3 - SN3270; ConvF(4.52, 4.52, 4.52); Calibrated: 2014/9/26
- Sensor-Surface: 2mm (Mechanical Surface Detection)
- Electronics: DAE4 Sn778; Calibrated: 2014/8/21
- Phantom: SAM_Right; Type: SAM; Serial: TP-1303
- ;Postprocessing SW: SEMCAD, V1.8 Build 159

Pin=250mW/Area Scan (61x61x1): Measurement grid: $dx=12\text{mm}$, $dy=12\text{mm}$

Maximum value of SAR (interpolated) = 19.8 mW/g

Pin=250mW/Zoom Scan (7x7x7)/Cube 0: Measurement grid: $dx=5\text{mm}$, $dy=5\text{mm}$, $dz=5\text{mm}$

Reference Value = 100.7 V/m ; Power Drift = 0.001 dB

Peak SAR (extrapolated) = 28.2 W/kg

SAR(1 g) = 13.9 mW/g ; SAR(10 g) = 6.54 mW/g

Maximum value of SAR (measured) = 18.0 mW/g

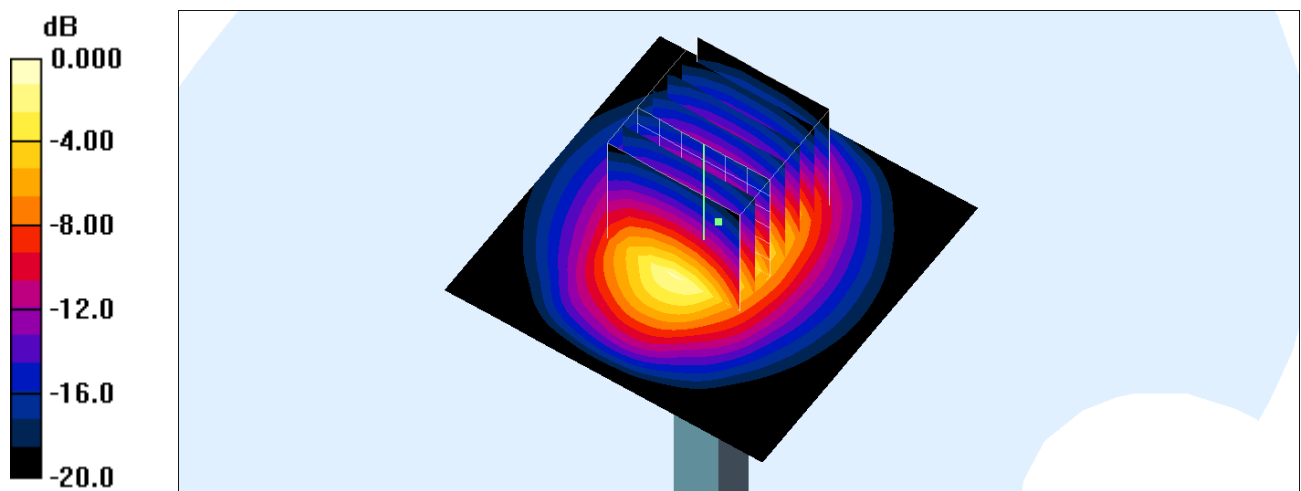

0 dB = 18.0mW/g

System Check_Head_2450MHz_141231

DUT: D2450V2-924

Communication System: CW; Frequency: 2450 MHz; Duty Cycle: 1:1

Medium: HSL_2450_141231 Medium parameters used: $f = 2450 \text{ MHz}$; $\sigma = 1.84 \text{ mho/m}$; $\epsilon_r = 38.6$; $\rho = 1000 \text{ kg/m}^3$

Ambient Temperature : $23.4 \text{ }^\circ\text{C}$; Liquid Temperature : $22.4 \text{ }^\circ\text{C}$

DASY4 Configuration:

- Probe: ES3DV3 - SN3270; ConvF(4.52, 4.52, 4.52); Calibrated: 2014/9/26
- Sensor-Surface: 2mm (Mechanical Surface Detection)
- Electronics: DAE4 Sn778; Calibrated: 2014/8/21
- Phantom: SAM_Right; Type: SAM; Serial: TP-1303
- ;Postprocessing SW: SEMCAD, V1.8 Build 159

Pin=250mW/Area Scan (61x61x1): Measurement grid: $dx=12\text{mm}$, $dy=12\text{mm}$

Maximum value of SAR (interpolated) = 20.1 mW/g

Pin=250mW/Zoom Scan (7x7x7)/Cube 0: Measurement grid: $dx=5\text{mm}$, $dy=5\text{mm}$, $dz=5\text{mm}$

Reference Value = 98.1 V/m ; Power Drift = -0.159 dB

Peak SAR (extrapolated) = 28.2 W/kg

SAR(1 g) = 13.2 mW/g ; SAR(10 g) = 5.99 mW/g

Maximum value of SAR (measured) = 17.4 mW/g

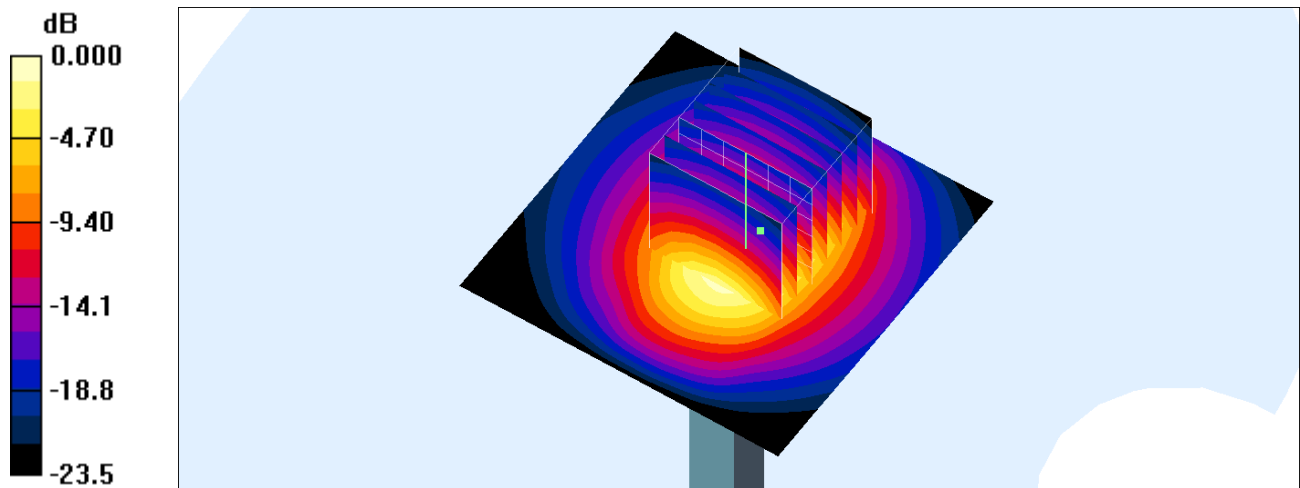

0 dB = 17.4mW/g

System Check_Body_2450MHz_150216

DUT: D2450V2-924

Communication System: CW; Frequency: 2450 MHz; Duty Cycle: 1:1

Medium: MSL_2450_150216 Medium parameters used: $f = 2450$ MHz; $\sigma = 1.984$ S/m; $\epsilon_r = 51.263$; $\rho = 1000$ kg/m³

Ambient Temperature : 23.4 °C; Liquid Temperature : 22.4 °C

DASY5 Configuration:

- Probe: EX3DV4 - SN3955; ConvF(7.32, 7.32, 7.32); Calibrated: 2014/11/21;
- Sensor-Surface: 1.4mm (Mechanical Surface Detection)
- Electronics: DAE4 Sn1399; Calibrated: 2014/11/13
- Phantom: SAM-Left; Type: QD 000 P40 C; Serial: TP-1478
- Measurement SW: DASY52, Version 52.8 (8); SEMCAD X Version 14.6.10 (7331)

Configuration/Pin=250mW/Area Scan (61x61x1): Interpolated grid: dx=1.200 mm, dy=1.200 mm

Maximum value of SAR (interpolated) = 18.8 W/kg

Configuration/Pin=250mW/Zoom Scan (7x7x7)/Cube 0: Measurement grid: dx=5mm, dy=5mm, dz=5mm

Reference Value = 91.74 V/m; Power Drift = 0.03 dB

Peak SAR (extrapolated) = 24.7 W/kg

SAR(1 g) = 12.1 W/kg; SAR(10 g) = 5.56 W/kg

Maximum value of SAR (measured) = 18.2 W/kg

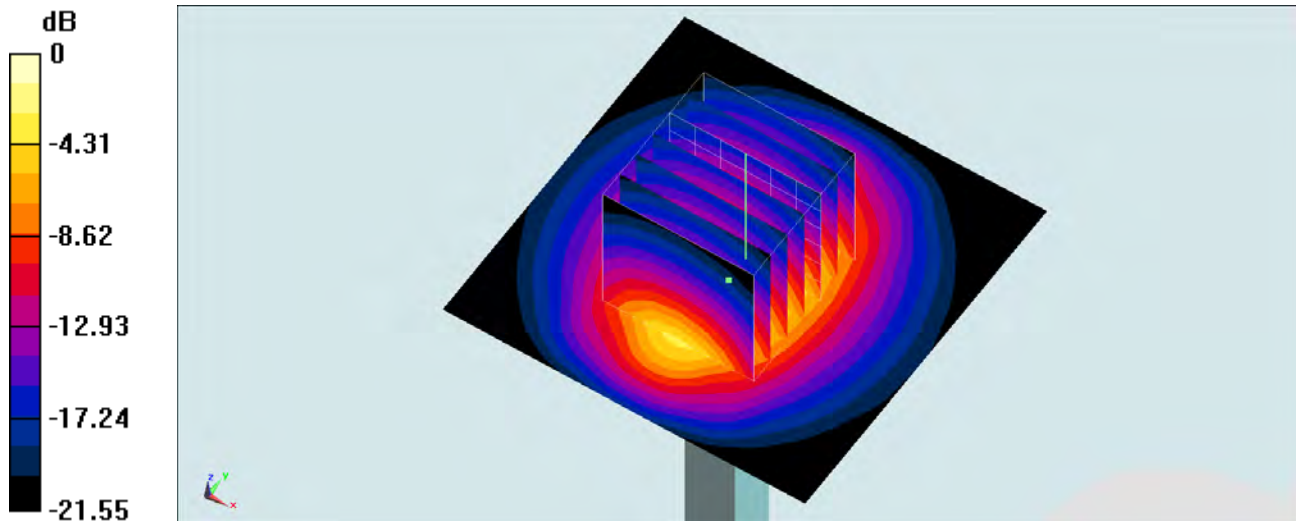

0 dB = 18.2 W/kg = 12.60 dBW/kg

System Check_Head_2600MHz_150225

DUT: D2600V2-1070

Communication System: CW; Frequency: 2600 MHz; Duty Cycle: 1:1

Medium: HSL_2600_150225 Medium parameters used: $f = 2600$ MHz; $\sigma = 2.042$ S/m; $\epsilon_r = 37.341$; $\rho = 1000$ kg/m³

Ambient Temperature : 23.5 °C; Liquid Temperature : 22.5 °C

DASY5 Configuration

- Probe: EX3DV4 - SN3954; ConvF(7.05, 7.05, 7.05); Calibrated: 2014/11/21;
- Sensor-Surface: 2mm (Mechanical Surface Detection)
- Electronics: DAE4 Sn1279; Calibrated: 2014/7/23
- Phantom: SAM LEFT; Type: QD000P40CD; Serial: TP:1718
- Measurement SW: DASY52, Version 52.8 (7); SEMCAD X Version 14.6.10 (7164)

Configuration/Pin=250mW/Area Scan (61x61x1): Interpolated grid: dx=1.200 mm, dy=1.200 mm

Maximum value of SAR (interpolated) = 24.4 W/kg

Configuration/Pin=250mW/Zoom Scan (7x7x7)/Cube 0: Measurement grid: dx=5mm, dy=5mm, dz=5mm

Reference Value = 105.8 V/m; Power Drift = -0.04 dB

Peak SAR (extrapolated) = 33.1 W/kg

SAR(1 g) = 14.6 W/kg; SAR(10 g) = 6.41 W/kg

Maximum value of SAR (measured) = 23.3 W/kg

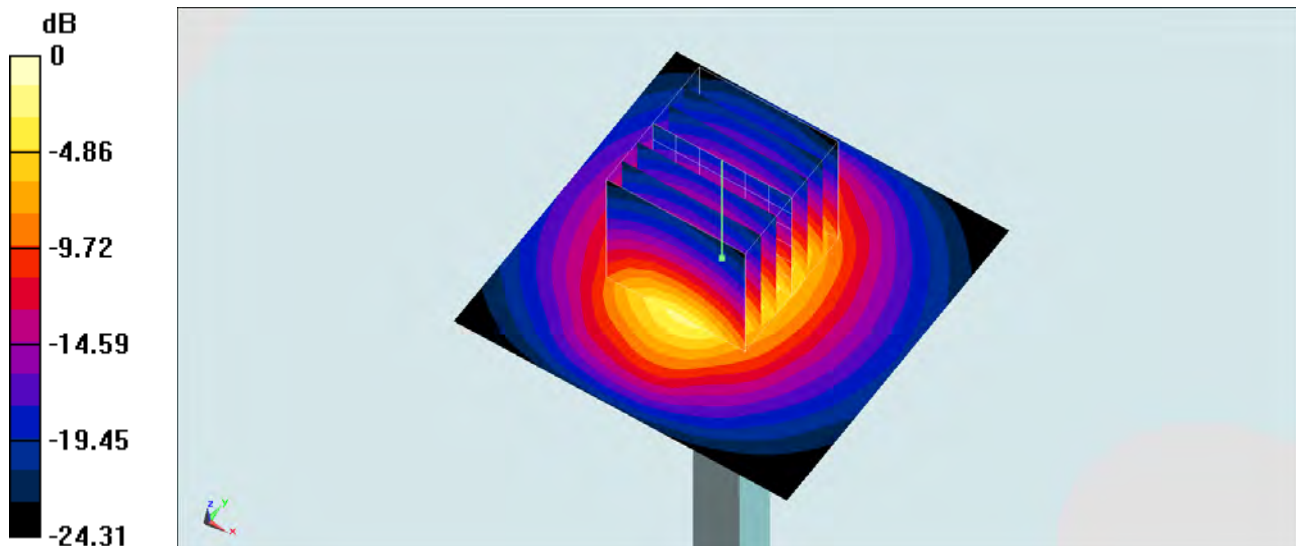

0 dB = 23.3 W/kg = 13.67 dBW/kg

System Check_Body_2600MHz_150224

DUT: D2600V2-1070

Communication System: CW ; Frequency: 2600 MHz;Duty Cycle: 1:1

Medium: MSL_2600_150224 Medium parameters used: $f = 2600$ MHz; $\sigma = 2.227$ S/m; $\epsilon_r = 52.208$; $\rho = 1000$ kg/m³

Ambient Temperature : 23.2 °C; Liquid Temperature : 22.2 °C

DASY5 Configuration

- Probe: EX3DV4 - SN3954; ConvF(7.07, 7.07, 7.07); Calibrated: 2014/11/21;
- Sensor-Surface: 1.4mm (Mechanical Surface Detection)
- Electronics: DAE4 Sn1279; Calibrated: 2014/7/23
- Phantom: SAM_RIGHT; Type: QD000P40CD; Serial: 1719
- Measurement SW: DASY52, Version 52.8 (7); SEMCAD X Version 14.6.10 (7164)

Configuration/Pin=250mW/Area Scan (61x61x1): Interpolated grid: dx=1.200 mm, dy=1.200 mm

Maximum value of SAR (interpolated) = 21.4 W/kg

Configuration/Pin=250mW/Zoom Scan (7x7x7)/Cube 0: Measurement grid: dx=5mm, dy=5mm, dz=5mm

Reference Value = 95.513 V/m; Power Drift = 0.12 dB

Peak SAR (extrapolated) = 29.1 W/kg

SAR(1 g) = 14 W/kg; SAR(10 g) = 6.5 W/kg

Maximum value of SAR (measured) = 21.3 W/kg

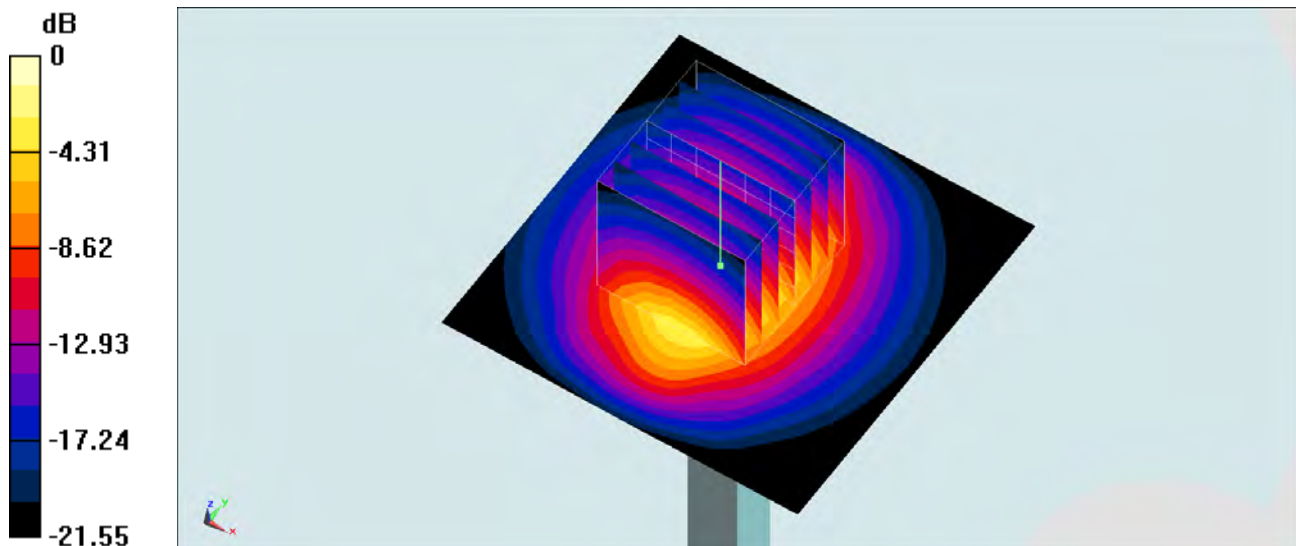

0 dB = 21.3 W/kg = 13.28 dBW/kg

System Check_Head_5200MHz_150216

DUT: D5GHzV2-1006

Communication System: CW; Frequency: 5200 MHz; Duty Cycle: 1:1

Medium: HSL_5G_150216 Medium parameters used: $f = 5200$ MHz; $\sigma = 4.812$ S/m; $\epsilon_r = 35.445$; $\rho = 1000$ kg/m³

Ambient Temperature : 23.4 °C; Liquid Temperature : 22.4 °C

DASY5 Configuration:

- Probe: EX3DV4 - SN3955; ConvF(5.13, 5.13, 5.13); Calibrated: 2014/11/21;
- Sensor-Surface: 1.4mm (Mechanical Surface Detection)
- Electronics: DAE4 Sn1399; Calibrated: 2014/11/13
- Phantom: SAM-Left; Type: QD 000 P40 C; Serial: TP-1478
- Measurement SW: DASY52, Version 52.8 (8); SEMCAD X Version 14.6.10 (7331)

Configuration/Pin=100mW/Area Scan (71x71x1): Interpolated grid: dx=1.000 mm, dy=1.000 mm

Maximum value of SAR (interpolated) = 20.5 W/kg

Configuration/Pin=100mW/Zoom Scan (7x7x7)/Cube 0: Measurement grid: dx=4mm, dy=4mm, dz=1.4mm

Reference Value = 71.15 V/m; Power Drift = 0.03 dB

Peak SAR (extrapolated) = 33.7 W/kg

SAR(1 g) = 8.32 W/kg; SAR(10 g) = 2.29 W/kg

Maximum value of SAR (measured) = 20.7 W/kg

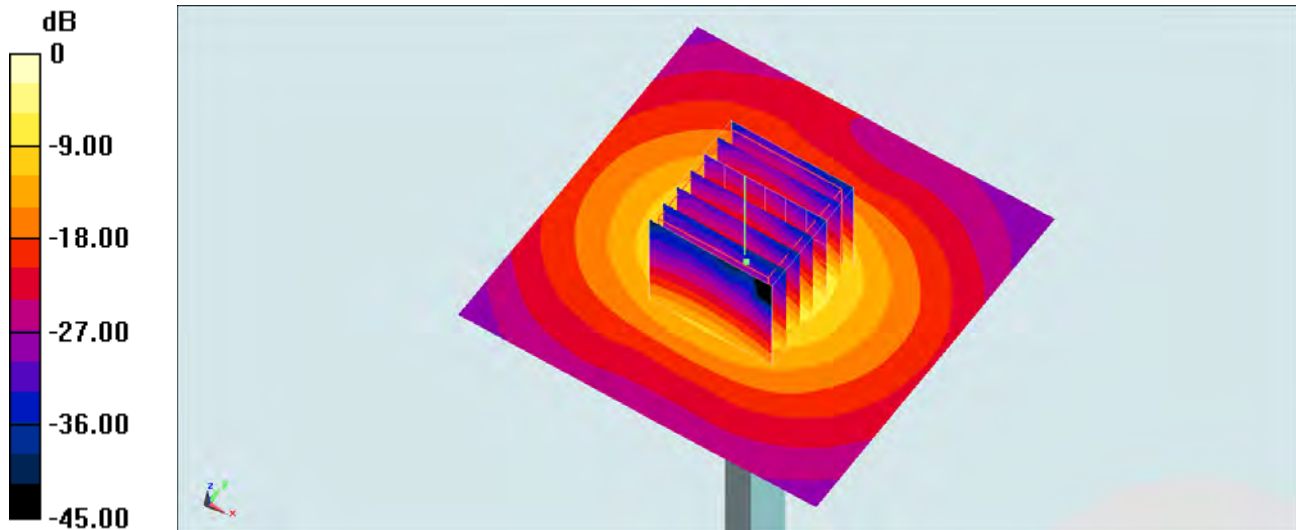

0 dB = 20.7 W/kg = 13.16 dBW/kg

System Check_Body_5200MHz_141226

DUT: D5GHzV2-1006

Communication System: CW; Frequency: 5200 MHz; Duty Cycle: 1:1

Medium: MSL_5G_141226 Medium parameters used: $f = 5200 \text{ MHz}$; $\sigma = 5.24 \text{ mho/m}$; $\epsilon_r = 47.5$; $\rho = 1000 \text{ kg/m}^3$

Ambient Temperature : $23.4 \text{ }^\circ\text{C}$; Liquid Temperature : $22.4 \text{ }^\circ\text{C}$

DASY4 Configuration:

- Probe: EX3DV4 - SN3925; ConvF(4.53, 4.53, 4.53); Calibrated: 2014/5/22
- Sensor-Surface: 1.4mm (Mechanical Surface Detection)
- Electronics: DAE3 Sn495; Calibrated: 2014/5/19
- Phantom: SAM_Right; Type: SAM; Serial: TP-1303
- ;Postprocessing SW: SEMCAD, V1.8 Build 159

Pin=100mW/Area Scan (71x71x1): Measurement grid: $dx=10\text{mm}$, $dy=10\text{mm}$

Maximum value of SAR (interpolated) = 18.9 mW/g

Pin=100mW/Zoom Scan (7x7x7)/Cube 0: Measurement grid: $dx=4\text{mm}$, $dy=4\text{mm}$, $dz=1.4\text{mm}$

Reference Value = 67.3 V/m ; Power Drift = -0.024 dB

Peak SAR (extrapolated) = 32.5 W/kg

SAR(1 g) = 7.79 mW/g ; SAR(10 g) = 2.13 mW/g

Maximum value of SAR (measured) = 19.1 mW/g

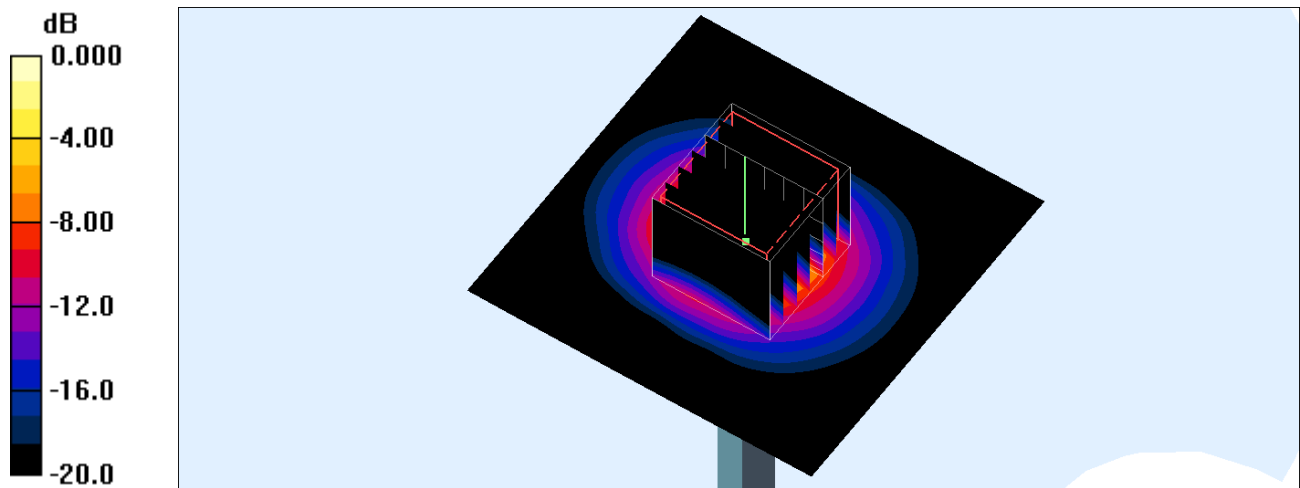

0 dB = 19.1mW/g

System Check_Body_5200MHz_150305

DUT: D5GHzV2-1006

Communication System: CW; Frequency: 5200 MHz; Duty Cycle: 1:1

Medium: MSL_5G_150305 Medium parameters used: $f = 5200$ MHz; $\sigma = 5.432$ S/m; $\epsilon_r = 47.957$; $\rho = 1000$ kg/m³

Ambient Temperature : 23.4 °C; Liquid Temperature : 22.4 °C

DASY5 Configuration

- Probe: EX3DV4 - SN3925; ConvF(4.53, 4.53, 4.53); Calibrated: 2014/5/22;
- Sensor-Surface: 1.4mm (Mechanical Surface Detection)
- Electronics: DAE3 Sn495; Calibrated: 2014/5/19
- Phantom: SAM_Left; Type: QD000P40CD; Serial: S/N:1796
- Measurement SW: DASY52, Version 52.8 (8); SEMCAD X Version 14.6.10 (7331)

Configuration/Pin=100mW/Area Scan (71x71x1): Interpolated grid: dx=1.000 mm, dy=1.000 mm

Maximum value of SAR (interpolated) = 17.9 W/kg

Configuration/Pin=100mW/Zoom Scan (7x7x7)/Cube 0: Measurement grid: dx=4mm, dy=4mm, dz=1.4mm

Reference Value = 64.34 V/m; Power Drift = 0.06 dB

Peak SAR (extrapolated) = 33.1 W/kg

SAR(1 g) = 7.83 W/kg; SAR(10 g) = 2.13 W/kg

Maximum value of SAR (measured) = 19.5 W/kg

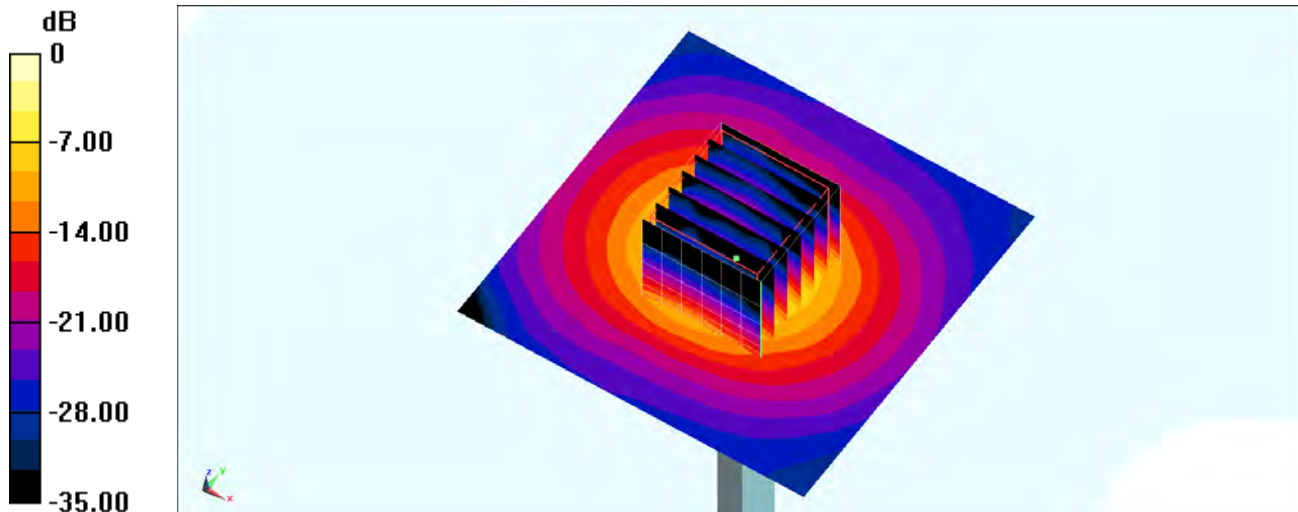

0 dB = 19.5 W/kg = 12.90 dBW/kg

System Check_Head_5300MHz_150216

DUT: D5GHzV2-1006

Communication System: CW; Frequency: 5300 MHz; Duty Cycle: 1:1

Medium: HSL_5G_150216 Medium parameters used: $f = 5300$ MHz; $\sigma = 4.92$ S/m; $\epsilon_r = 35.315$; $\rho = 1000$ kg/m³

Ambient Temperature : 23.4 °C; Liquid Temperature : 22.4 °C

DASY5 Configuration:

- Probe: EX3DV4 - SN3955; ConvF(4.92, 4.92, 4.92); Calibrated: 2014/11/21;
- Sensor-Surface: 1.4mm (Mechanical Surface Detection)
- Electronics: DAE4 Sn1399; Calibrated: 2014/11/13
- Phantom: SAM-Left; Type: QD 000 P40 C; Serial: TP-1478
- Measurement SW: DASY52, Version 52.8 (8); SEMCAD X Version 14.6.10 (7331)

Configuration/Pin=100mW/Area Scan (71x71x1): Interpolated grid: dx=1.000 mm, dy=1.000 mm

Maximum value of SAR (interpolated) = 21.8 W/kg

Configuration/Pin=100mW/Zoom Scan (7x7x7)/Cube 0: Measurement grid: dx=4mm, dy=4mm, dz=1.4mm

Reference Value = 72.65 V/m; Power Drift = 0.03 dB

Peak SAR (extrapolated) = 35.9 W/kg

SAR(1 g) = 8.87 W/kg; SAR(10 g) = 2.44 W/kg

Maximum value of SAR (measured) = 22.0 W/kg

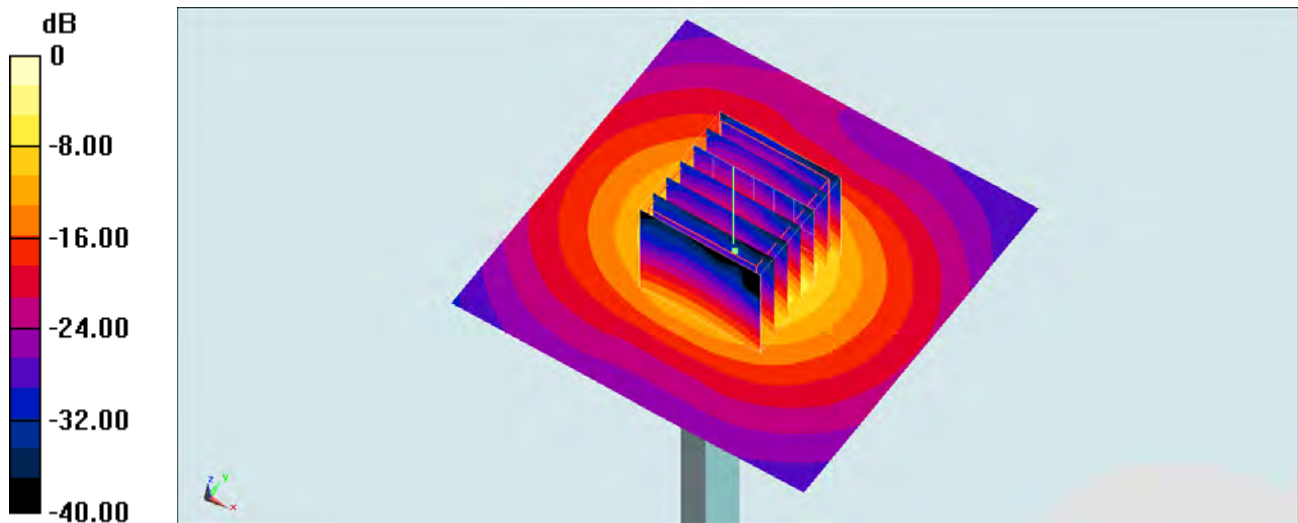

0 dB = 22.0 W/kg = 13.42 dBW/kg

System Check_Body_5300MHz_141226

DUT: D5GHzV2-1006

Communication System: CW; Frequency: 5300 MHz; Duty Cycle: 1:1

Medium: MSL_5G_141226 Medium parameters used: $f = 5300 \text{ MHz}$; $\sigma = 5.38 \text{ mho/m}$; $\epsilon_r = 47.2$; $\rho = 1000 \text{ kg/m}^3$

Ambient Temperature : $23.4 \text{ }^\circ\text{C}$; Liquid Temperature : $22.4 \text{ }^\circ\text{C}$

DASY4 Configuration:

- Probe: EX3DV4 - SN3925; ConvF(4.36, 4.36, 4.36); Calibrated: 2014/5/22
- Sensor-Surface: 1.4mm (Mechanical Surface Detection)
- Electronics: DAE3 Sn495; Calibrated: 2014/5/19
- Phantom: SAM_Right; Type: SAM; Serial: TP-1303
- ;Postprocessing SW: SEMCAD, V1.8 Build 159

Pin=100mW/Area Scan (71x71x1): Measurement grid: $dx=10\text{mm}$, $dy=10\text{mm}$

Maximum value of SAR (interpolated) = 19.4 mW/g

Pin=100mW/Zoom Scan (7x7x7)/Cube 0: Measurement grid: $dx=4\text{mm}$, $dy=4\text{mm}$, $dz=1.4\text{mm}$

Reference Value = 68.4 V/m ; Power Drift = -0.070 dB

Peak SAR (extrapolated) = 34.7 W/kg

SAR(1 g) = 7.97 mW/g ; SAR(10 g) = 2.16 mW/g

Maximum value of SAR (measured) = 19.8 mW/g

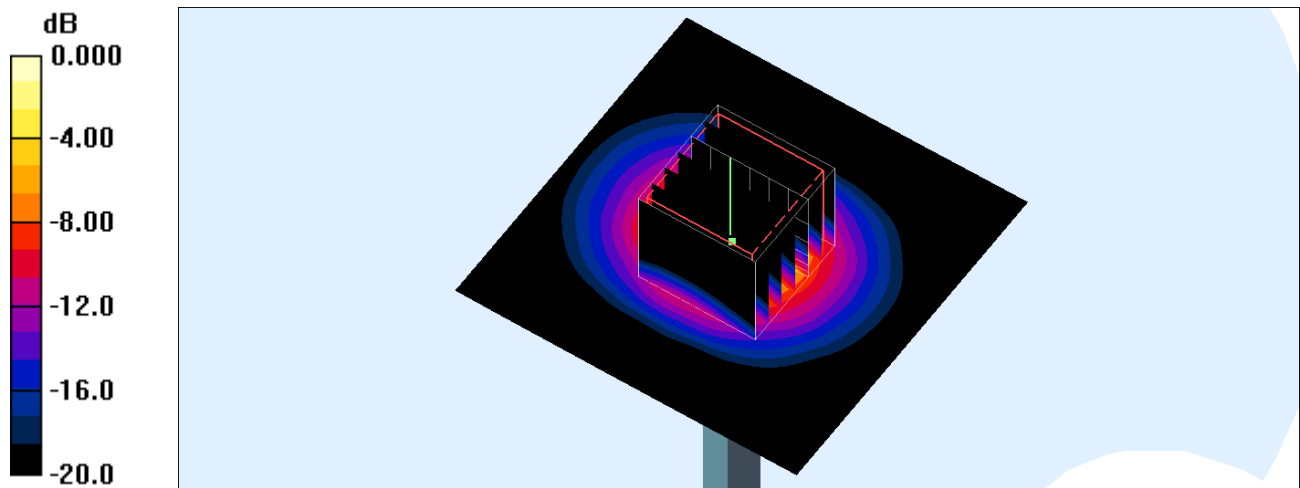

0 dB = 19.8mW/g

System Check_Head_5600MHz_150216

DUT: D5GHzV2-1006

Communication System: CW; Frequency: 5600 MHz; Duty Cycle: 1:1

Medium: HSL_5G_150216 Medium parameters used: $f = 5600$ MHz; $\sigma = 5.231$ S/m; $\epsilon_r = 34.71$; $\rho = 1000$ kg/m³

Ambient Temperature : 23.4 °C; Liquid Temperature : 22.4 °C

DASY5 Configuration:

- Probe: EX3DV4 - SN3955; ConvF(4.56, 4.56, 4.56); Calibrated: 2014/11/21;
- Sensor-Surface: 1.4mm (Mechanical Surface Detection)
- Electronics: DAE4 Sn1399; Calibrated: 2014/11/13
- Phantom: SAM-Left; Type: QD 000 P40 C; Serial: TP-1478
- Measurement SW: DASY52, Version 52.8 (8); SEMCAD X Version 14.6.10 (7331)

Configuration/Pin=100mW/Area Scan (71x71x1): Interpolated grid: dx=1.000 mm, dy=1.000 mm

Maximum value of SAR (interpolated) = 23.9 W/kg

Configuration/Pin=100mW/Zoom Scan (7x7x7)/Cube 0: Measurement grid: dx=4mm, dy=4mm, dz=1.4mm

Reference Value = 74.04 V/m; Power Drift = 0.07 dB

Peak SAR (extrapolated) = 41.0 W/kg

SAR(1 g) = 9.21 W/kg; SAR(10 g) = 2.56 W/kg

Maximum value of SAR (measured) = 23.8 W/kg

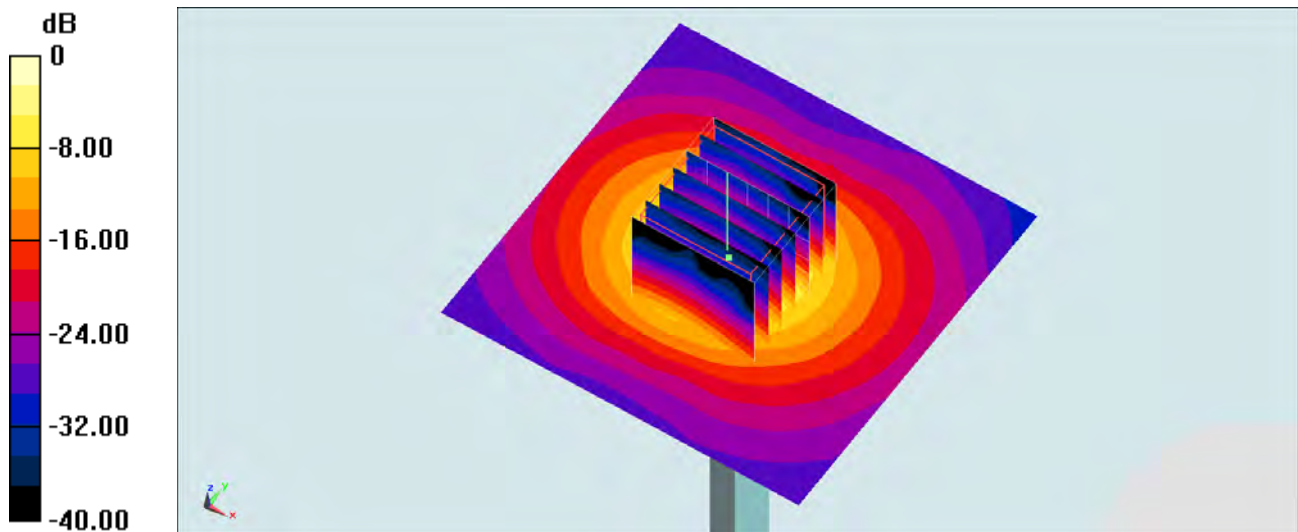

0 dB = 23.8 W/kg = 13.77 dBW/kg

System Check_Body_5600MHz_141226

DUT: D5GHzV2-1006

Communication System: CW; Frequency: 5600 MHz; Duty Cycle: 1:1

Medium: MSL_5G_141226 Medium parameters used: $f = 5600 \text{ MHz}$; $\sigma = 5.77 \text{ mho/m}$; $\epsilon_r = 46.8$; $\rho = 1000 \text{ kg/m}^3$

Ambient Temperature : $23.4 \text{ }^\circ\text{C}$; Liquid Temperature : $22.4 \text{ }^\circ\text{C}$

DASY4 Configuration:

- Probe: EX3DV4 - SN3925; ConvF(4.12, 4.12, 4.12); Calibrated: 2014/5/22
- Sensor-Surface: 1.4mm (Mechanical Surface Detection)
- Electronics: DAE3 Sn495; Calibrated: 2014/5/19
- Phantom: SAM_Right; Type: SAM; Serial: TP-1303
- ;Postprocessing SW: SEMCAD, V1.8 Build 159

Pin=100mW/Area Scan (71x71x1): Measurement grid: $dx=10\text{mm}$, $dy=10\text{mm}$

Maximum value of SAR (interpolated) = 21.3 mW/g

Pin=100mW/Zoom Scan (7x7x7)/Cube 0: Measurement grid: $dx=4\text{mm}$, $dy=4\text{mm}$, $dz=1.4\text{mm}$

Reference Value = 69.8 V/m ; Power Drift = 0.070 dB

Peak SAR (extrapolated) = 38.5 W/kg

SAR(1 g) = 8.32 mW/g ; SAR(10 g) = 2.25 mW/g

Maximum value of SAR (measured) = 21.3 mW/g

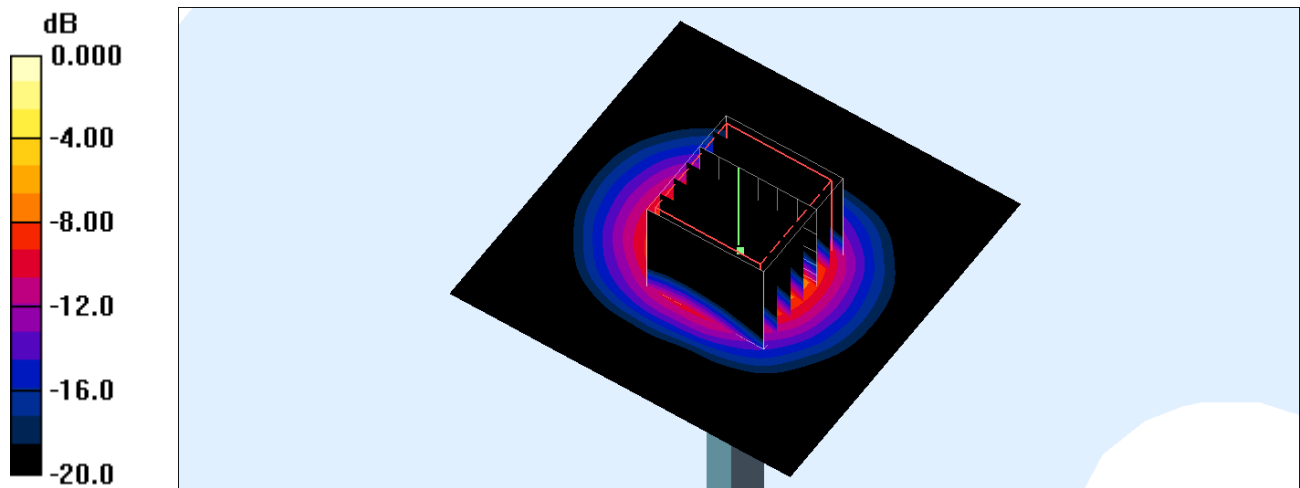

0 dB = 21.3mW/g

System Check_Head_5800MHz_141225

DUT: D5GHzV2-1006

Communication System: CW; Frequency: 5800 MHz; Duty Cycle: 1:1

Medium: HSL_5G_141225 Medium parameters used: $f = 5800 \text{ MHz}$; $\sigma = 5.39 \text{ mho/m}$; $\epsilon_r = 34.4$; $\rho = 1000 \text{ kg/m}^3$

Ambient Temperature : $23.5 \text{ }^\circ\text{C}$; Liquid Temperature : $22.5 \text{ }^\circ\text{C}$

DASY4 Configuration:

- Probe: EX3DV4 - SN3925; ConvF(4.63, 4.63, 4.63); Calibrated: 2014/5/22
- Sensor-Surface: 1.4mm (Mechanical Surface Detection)
- Electronics: DAE3 Sn495; Calibrated: 2014/5/19
- Phantom: SAM_Right; Type: SAM; Serial: TP-1303
- ;Postprocessing SW: SEMCAD, V1.8 Build 159

Pin=100mW/Area Scan (71x71x1): Measurement grid: dx=10mm, dy=10mm

Maximum value of SAR (interpolated) = 23.9 mW/g

Pin=100mW/Zoom Scan (7x7x7)/Cube 0: Measurement grid: dx=4mm, dy=4mm, dz=1.4mm

Reference Value = 40.7 V/m ; Power Drift = 0.056 dB

Peak SAR (extrapolated) = 40.7 W/kg

SAR(1 g) = 8.75 mW/g ; SAR(10 g) = 2.35 mW/g

Maximum value of SAR (measured) = 22.4 mW/g

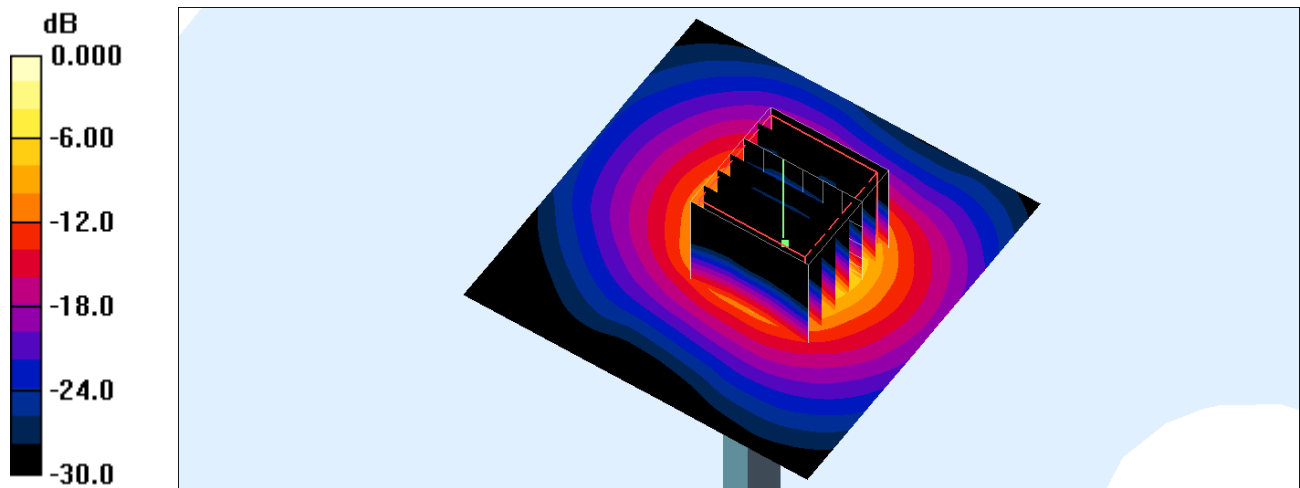

0 dB = 22.4 mW/g

System Check_Body_5800MHz_141226

DUT: D5GHzV2-1006

Communication System: CW; Frequency: 5800 MHz; Duty Cycle: 1:1

Medium: MSL_5G_141226 Medium parameters used: $f = 5800 \text{ MHz}$; $\sigma = 6.13 \text{ mho/m}$; $\epsilon_r = 46.5$; $\rho = 1000 \text{ kg/m}^3$

Ambient Temperature : $23.4 \text{ }^\circ\text{C}$; Liquid Temperature : $22.4 \text{ }^\circ\text{C}$

DASY4 Configuration:

- Probe: EX3DV4 - SN3925; ConvF(4.09, 4.09, 4.09); Calibrated: 2014/5/22
- Sensor-Surface: 1.4mm (Mechanical Surface Detection)
- Electronics: DAE3 Sn495; Calibrated: 2014/5/19
- Phantom: SAM_Right; Type: SAM; Serial: TP-1303
- ;Postprocessing SW: SEMCAD, V1.8 Build 159

Pin=100mW/Area Scan (71x71x1): Measurement grid: $dx=10\text{mm}$, $dy=10\text{mm}$

Maximum value of SAR (interpolated) = 22.4 mW/g

Pin=100mW/Zoom Scan (7x7x7)/Cube 0: Measurement grid: $dx=4\text{mm}$, $dy=4\text{mm}$, $dz=1.4\text{mm}$

Reference Value = 69.6 V/m ; Power Drift = -0.128 dB

Peak SAR (extrapolated) = 35.8 W/kg

SAR(1 g) = 8.4 mW/g ; SAR(10 g) = 2.29 mW/g

Maximum value of SAR (measured) = 21.0 mW/g

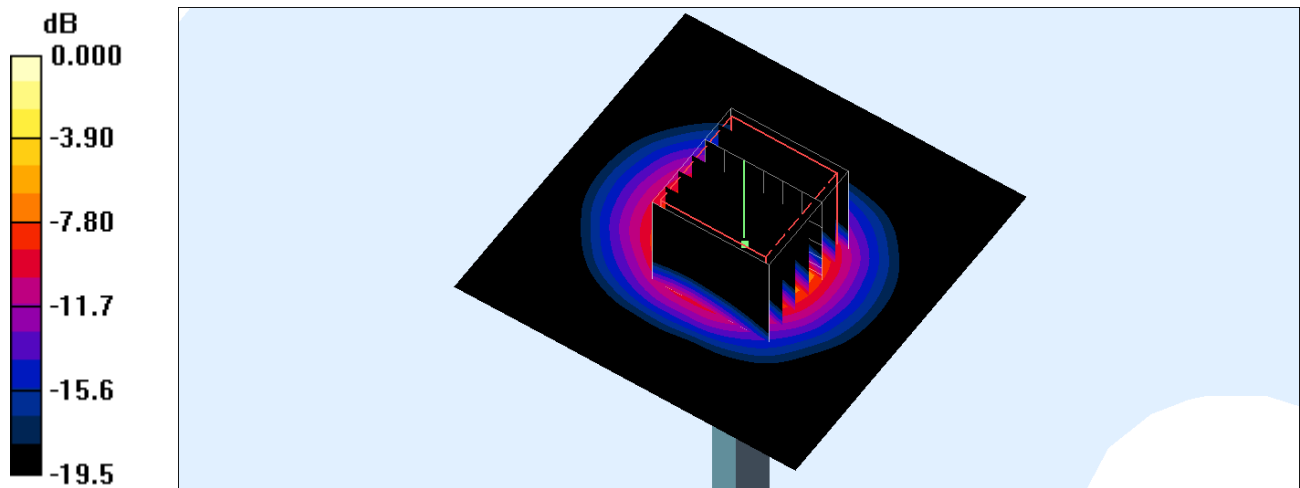

0 dB = 21.0mW/g

System Check_Body_5800MHz_150305

DUT: D5GHzV2-1006

Communication System: CW; Frequency: 5800 MHz; Duty Cycle: 1:1

Medium: MSL_5G_150305 Medium parameters used: $f = 5800 \text{ MHz}$; $\sigma = 6.251 \text{ S/m}$; $\epsilon_r = 46.901$; $\rho = 1000 \text{ kg/m}^3$

Ambient Temperature : $23.4 \text{ }^\circ\text{C}$; Liquid Temperature : $22.4 \text{ }^\circ\text{C}$

DASY5 Configuration

- Probe: EX3DV4 - SN3925; ConvF(4.09, 4.09, 4.09); Calibrated: 2014/5/22;
- Sensor-Surface: 1.4mm (Mechanical Surface Detection)
- Electronics: DAE3 Sn495; Calibrated: 2014/5/19
- Phantom: SAM_Left; Type: QD000P40CD; Serial: S/N:1796
- Measurement SW: DASY52, Version 52.8 (8); SEMCAD X Version 14.6.10 (7331)

Configuration/Pin=100mW/Area Scan (71x71x1): Interpolated grid: $dx=1.000 \text{ mm}$, $dy=1.000 \text{ mm}$

Maximum value of SAR (interpolated) = 19.7 W/kg

Configuration/Pin=100mW/Zoom Scan (7x7x7)/Cube 0: Measurement grid: $dx=4\text{mm}$, $dy=4\text{mm}$, $dz=1.4\text{mm}$

Reference Value = 59.24 V/m ; Power Drift = 0.08 dB

Peak SAR (extrapolated) = 36.7 W/kg

SAR(1 g) = 7.77 W/kg ; SAR(10 g) = 2.1 W/kg

Maximum value of SAR (measured) = 20.2 W/kg

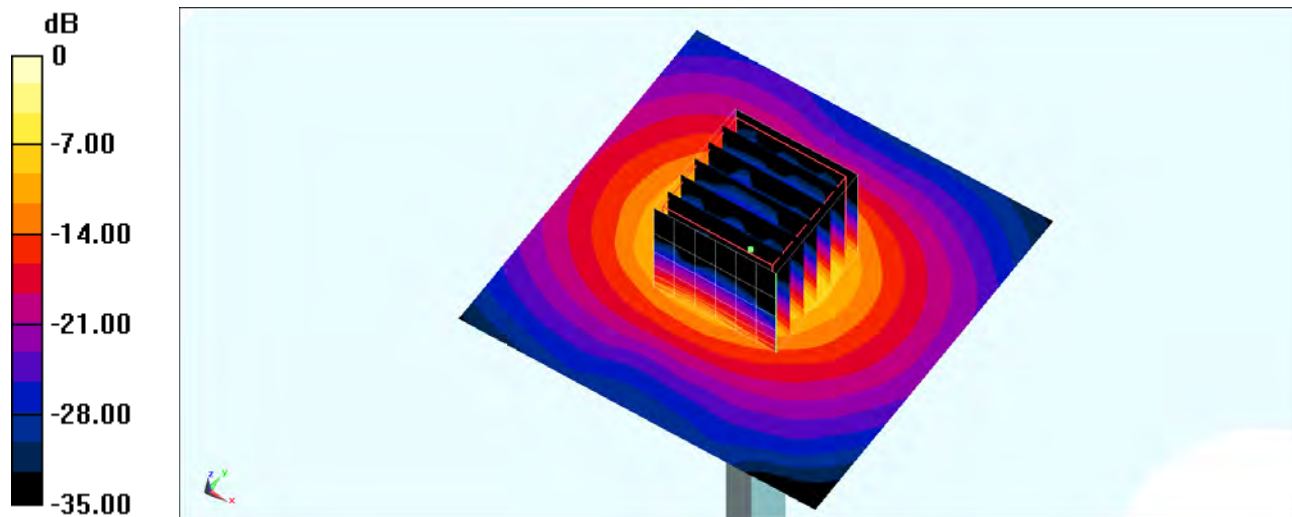

$0 \text{ dB} = 20.2 \text{ W/kg} = 13.05 \text{ dBW/kg}$