



C2PC CERTIFICATION TEST REPORT

FCC CFR47 PART 27 SUBPART M

CERTIFICATION TEST REPORT

GSM/WCDMA/LTE PHONE with BT, DTS/UNII a/b/g/n/ac & NFC

FCC ID: PY7-96946K

REPORT NUMBER: 16J23633D-E1V4

ISSUE DATE: 8/22/2016

Prepared for

**SONY MOBILE COMMUNICATIONS INC.
4-12-3 HIGASHI-SHINAGAWA,
SHINAGAWA -KU, TOKYO, 140-0002, JAPAN**

Prepared by

**UL LLC
12 LABORATORY DRIVE
RESEARCH TRIANGLE PARK, NC 27709 USA
TEL: (919) 549-1400**



NVLAP Lab code: 200246-0

Revision History

Ver.	Issue Date	Revisions	Revised By
1	8/8/16	Initial Issue	C.S.OOI
2	8/22/16	Changed UL address to RTP, NC USA location, removed references to FCC rule parts, revised reference to TIA-603 to 'D', added Section 5.2 C2PC information, added note to power summary tables, deleted all conducted data, revised antenna gains, corrected tabular power values and channel frequencies (Sec. 9.1.1).	Jeff Moser
3	8/22/16	Revised Cover Page, Section 1, Section 2, Section 7.1 and Section 7.2	C.S.OOI
4	8/22/16	Revised Section 7.1	C.S.OOI

TABLE OF CONTENTS

1. ATTESTATION OF TEST RESULTS 4

2. TEST METHODOLOGY 5

3. FACILITIES AND ACCREDITATION 5

4. CALIBRATION AND UNCERTAINTY 6

 4.1. *MEASURING INSTRUMENT CALIBRATION 6*

 4.2. *SAMPLE CALCULATION 6*

 4.3. *MEASUREMENT UNCERTAINTY 6*

5. EQUIPMENT UNDER TEST 7

 5.1. *DESCRIPTION OF EUT 7*

 5.2. *DESCRIPTION OF CLASS II PERMISSIVE CHANGE 7*

 5.3. *MAXIMUM OUTPUT POWER (LTE) 7*

 5.4. *DESCRIPTION OF AVAILABLE ANTENNAS 8*

 5.5. *DESCRIPTION OF TEST SETUP 9*

6. TEST AND MEASUREMENT EQUIPMENT 11

7. RADIATED TEST RESULTS 13

 7.1. *RADIATED POWER (ERP & EIRP) 13*

 7.1.1. *ERP/EIRP RESULTS AND TABLE 14*

 7.2. *FIELD STRENGTH OF SPURIOUS RADIATION 20*

 7.2.1. *SPURIOUS RADIATION PLOTS 21*

8. SETUP PHOTOS 25

1. ATTESTATION OF TEST RESULTS

COMPANY NAME: SONY MOBILE COMMUNICATIONS, INC.
EUT DESCRIPTION: GSM/WCDMA/LTE Phone with BT, BLE, DTS/UNII a/b/g/n/ac & NFC
SERIAL NUMBER: CB512ATJUG, CB512AU2RJ
DATE TESTED: AUGUST 01- 03, 2016

APPLICABLE STANDARDS	
STANDARD	TEST RESULTS
FCC PART 27M	PASS

UL LLC tested the above equipment in accordance with the requirements set forth in the above standards. All indications of Pass/Fail in this report are opinions expressed by UL LLC based on interpretations and/or observations of test results. Measurement Uncertainties were not taken into account and are published for informational purposes only. The test results show that the equipment tested is capable of demonstrating compliance with the requirements as documented in this report.

Note: The results documented in this report apply only to the tested sample, under the conditions and modes of operation as described herein. This document may not be altered or revised in any way unless done so by UL LLC and all revisions are duly noted in the revisions section. Any alteration of this document not carried out by UL LLC will constitute fraud and shall nullify the document. This report must not be used by the client to claim product certification, approval, or endorsement by NVLAP, NIST, any agency of the Federal Government, or any agency of any government.

Approved & Released

For UL LLC By:



CHOON OOI
CONSUMER TECHNOLOGY DIVISION
WISE PROJECT LEAD
UL VERIFICATION SERVICES INC

Prepared By:



KIYA KEDIDA
CONSUMER TECHNOLOGY DIVISION
WISE LAB ENGINEER
UL VERIFICATION SERVICES INC

2. TEST METHODOLOGY

The tests documented in this report were performed in accordance with Part 27 and TIA-603-D

3. FACILITIES AND ACCREDITATION

The test sites and measurement facilities used to collect data are located at 12 Laboratory Dr., Research Triangle Park, NC 27709, USA and 2800 Suite B, Perimeter Park Drive, Morrisville, NC 27560.

12 Laboratory Dr., RTP, NC 27709
<input type="checkbox"/> Chamber A
<input type="checkbox"/> Chamber C

2800 Suite B Perimeter Park Dr., Morrisville, NC 27560
<input checked="" type="checkbox"/> Chamber NORTH
<input type="checkbox"/> Chamber SOUTH

UL LLC (RTP) is accredited by NVLAP, Laboratory Code 200246-0. The full scope of accreditation can be viewed at <http://www.nist.gov/nvlap/>

4. CALIBRATION AND UNCERTAINTY

4.1. MEASURING INSTRUMENT CALIBRATION

The measuring equipment utilized to perform the tests documented in this report has been calibrated in accordance with the manufacturer's recommendations, and is traceable to recognized national standards

4.2. SAMPLE CALCULATION

Where relevant, the following sample calculation is provided:

EIRP = PSA reading with EUT worst orientation (dBm) + Path loss (dB) – cable loss(between the SG and substitution antenna) + Substitution Antenna Factor (dBi)

ERP = PSA reading with EUT worst orientation (dBm) + Path loss (dB) – cable loss(between the SG and substitution antenna)

(Path loss = Signal generator output – PSA reading with substitution antenna)

4.3. MEASUREMENT UNCERTAINTY

Where relevant, the following measurement uncertainty levels have been estimated for tests performed on the apparatus:

PARAMETER	UNCERTAINTY
Total RF power, conducted	±0.45 dB
RF power density, conducted	±1.5 dB
Spurious emissions, conducted	±2.94 dB
All emissions, radiated up to 40 GHz	±5.36 dB
Temperature	±0.07°C
Humidity	±2.26% RH
DC and low frequency voltages	±1.27%
Conducted Emissions (0.150-30MHz)	±2.37dB

Uncertainty figures are valid to a confidence level of 95%.

5. EQUIPMENT UNDER TEST

5.1. DESCRIPTION OF EUT

This EUT is a GSM/WCDMA/LTE PHONE + BLUETOOTH, DTS/UNII a/b/g/n/ac & NFC.

5.2. DESCRIPTION OF CLASS II PERMISSIVE CHANGE

The purpose of this C2PC: Changed the LTE band 7 and LTE Band 41 antenna matching circuit.

5.3. MAXIMUM OUTPUT POWER (LTE)

The transmitter has a maximum peak conducted and radiated ERP/EIRP output powers as follows:

LTE Band 7

Band	Frequency Range(MHz)	BandWidth (MHz)	Modulation	Radiated	
				Peak(dBm)	Peak(mW)
LTE7	2500~2570	5MHz	QPSK	24.14	259.42
			16QAM	24.16	260.62
		10MHz	QPSK	23.58	228.03
			16QAM	23.77	238.23
		15MHz	QPSK	22.31	170.22
			16QAM	22.49	177.42
		20MHz	QPSK	23.44	220.80
			16QAM	23.60	229.09

Note - Power measurements indicate that output radiated power is within 0.5dB of the originally reported power for this FCC ID. This is well within measurement uncertainty.

LTE Band 41

Band	Frequency Range(MHz)	BandWidth (MHz)	Modulation	Radiated	
				Peak(dBm)	Peak(mW)
LTE41	2496~2690	5MHz	QPSK	26.88	487.53
			16QAM	26.82	480.84
		10MHz	QPSK	26.74	472.06
			16QAM	26.75	473.15
		15MHz	QPSK	26.52	448.75
			16QAM	26.54	450.82
		20MHz	QPSK	26.75	473.15
			16QAM	26.76	474.24

Note - Power measurements indicate that output radiated power is within 0.5dB of the originally reported power for this FCC ID. This is well within measurement uncertainty.

5.4. DESCRIPTION OF AVAILABLE ANTENNAS

The radio utilizes a PIFA antenna for the [List the bands supported] with a maximum peak gain as follow:

Frequency (MHz)	Peak Gain (dBi)
LTE Band 7, 2500~2570MHz	-1.8
LTE Band 41, 2496~2690MHz	-1.4

5.5. DESCRIPTION OF TEST SETUP

SUPPORT EQUIPMENT

Support Equipment List				
Description	Manufacturer	Model	Serial Number	FCC ID
AC Adapter	SONY	1300-7146.1B	5816W02400051	N/A
Earphone	SONY	12271A100010396	12271A100010396	N/A

I/O CABLES (RADIATED SETUP)

I/O Cable List						
Cable No	Port	# of Identical ports	Connector Type	Serial Type	Cable Length (m)	Remarks
1	USB	1	AC Adapter	Un-shielded	1.2m	No
2	Audio	1	3.5mm	Shielded	>1m	Headset
3	RF In/out	1	Communication Test Set	Un-shielded	2m	Yes

TEST SETUP

The EUT is continuously communicated to the call box during the tests.

SETUP DIAGRAM FOR TESTS (RADIATED TEST SETUP)

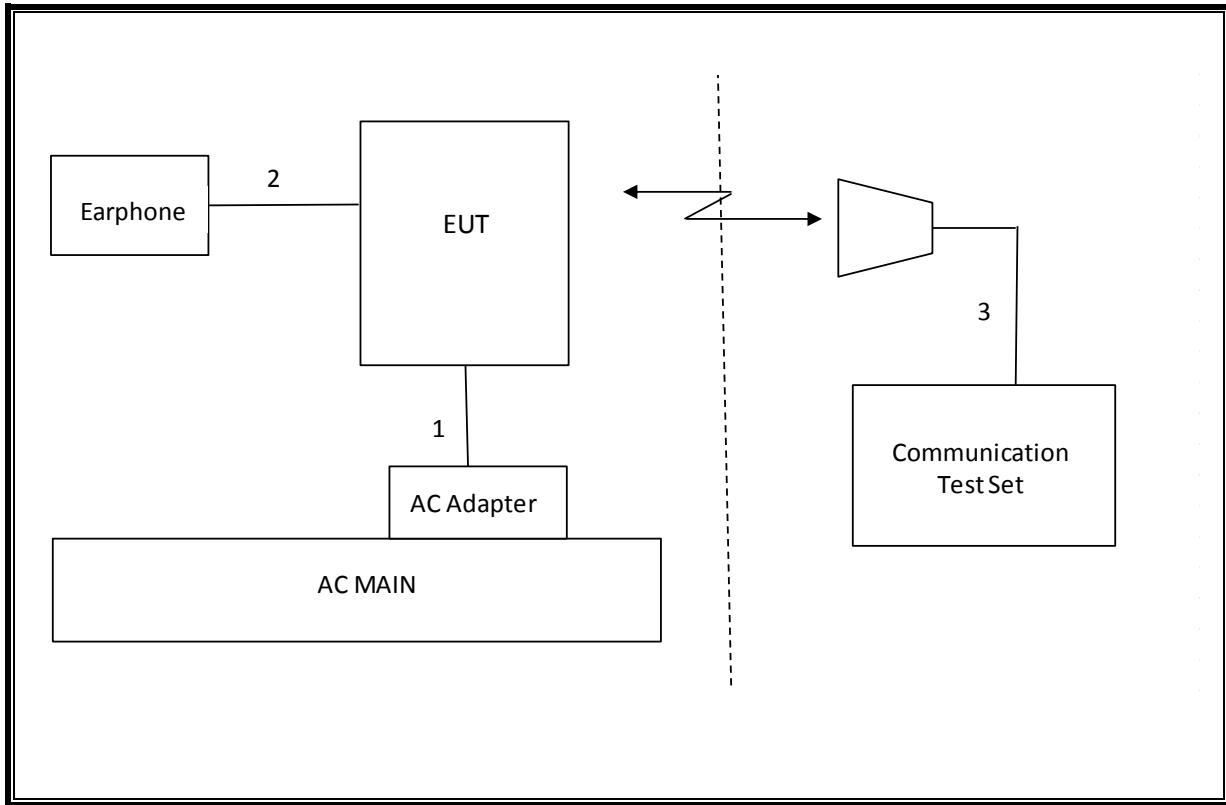

6. TEST AND MEASUREMENT EQUIPMENT

The following test and measurement equipment was utilized for the tests documented in this report:

Equip. ID	Description	Manufacturer	Model Number	Last Cal.	Next Cal.
	30-1000 MHz				
AT0073	Hybrid Broadband Antenna	Sunol Sciences Corp.	JB3	2016-06-27	2017-06-27
	1-18 GHz				
AT0072	Double-Ridged Waveguide Horn Antenna, 1 to 18 GHz	ETS Lindgren	3117	2016-03-07	2017-03-31
	Tuned Dipole Set				
AT0013-AT0016	Four Dipole Antenna Set, 30 to 1000 MHz	EMCO	3121C-DB-1, -2, -3, -4	2016-06-14	2017-06-14
	Gain-Loss Chains				
N-SAC01	Gain-loss string: 0.009-30MHz	Various	Various	2015-10-07	2016-10-31
N-SAC02	Gain-loss string: 30-1000MHz	Various	Various	2016-06-26	2017-06-16
N-SAC03	Gain-loss string: 1-18GHz	Various	Various	2015-09-29	2016-09-30
	Receiver & Software				
SA0027	Spectrum Analyzer	Agilent	N9030A	2016-02-08	2017-02-08
T374	Wideband Radio Communications Tester	Rohde and Schwartz	CMW500	2015-10-21	2016-10-31
SOFTEMI	EMI Software	UL	Version 9.5	NA	NA
	Additional Equipment used				
HI0078	Temp/Humid/Pressure Meter (Module)	Springfield Precision	PreciseTemp	2016-06-13	2017-06-13

Equip. ID	Description	Manufacturer	Model Number	Last Cal.	Next Cal.
AT0078	Double-Ridged Waveguide Horn Antenna, 1 to 18 GHz. Used for substitution.	ETS Lindgren	3117	2015-10-15	2016-10-31

7. RADIATED TEST RESULTS

7.1. RADIATED POWER (ERP & EIRP)

RULE PART(S)

FCC: §27

LIMITS

27.50 (h) - (2) Mobile stations are limited to 2.0 watts EIRP. All user stations are limited to 2.0 watts transmitter output power. (LTE B41 & 7)

TEST PROCEDURE

ANSI / TIA / EIA 603-D; PSA setting reference to 971168 D01 v02r02

For peak power measurement with a PSA:

a) Set the RBW \geq OBW; b) Set VBW $\geq 3 \times$ RBW; c) Set span $\geq 2 \times$ RBW; d) Sweep time = auto couple; e) Detector = peak; f) Ensure that the number of measurement points \geq span/RBW; g) Trace mode = max hold;

For average power measurement with a PSA:

- a) Set span to at least 1.5 times the OBW; b) Set RBW = 1-5% of the OBW, not to exceed 1 MHz; c) Set VBW $\geq 3 \times$ RBW; d) Set number of points in sweep $\geq 2 \times$ span / RBW; e) Sweep time = auto-couple; f) Detector = RMS (power averaging); g) Use free run trigger if burst duty cycle ≥ 98 ; h) Use trigger to capture bursts if burst duty cycle < 98 ; i) Trace average at least 100 traces in power averaging (*i.e.*, RMS) mode. j) Compute the power by integrating the spectrum across the OBW of the signal using the instrument's band power measurement function.

7.1.1. ERP/EIRP RESULTS AND TABLE

LTE Band 7

BW (MHz)	Mode	RB/RB Size	f(MHz)	EIRP (Peak)	
				dBm	mW
5	QPSK	1/0	2502.5	21.78	150.66
		1/0	2535	22.65	184.08
		1/0	2567.5	24.14	259.42
	16QAM	1/0	2502.5	21.72	148.59
		1/0	2535	22.68	185.35
		1/0	2567.5	24.16	260.62
10	QPSK	1/0	2505	21.45	139.64
		1/0	2535	22.52	178.65
		1/0	2565	23.58	228.03
	16QAM	1/0	2505	21.54	142.56
		1/0	2535	22.57	180.72
		1/0	2565	23.77	238.23
15	QPSK	1/0	2507.5	20.36	108.64
		1/0	2535	21.97	157.40
		1/0	2562.5	22.31	170.22
	16QAM	1/0	2507.5	20.49	111.94
		1/0	2535	21.99	158.12
		1/0	2562.5	22.49	177.42
20	QPSK	1/0	2510	21.07	127.94
		1/0	2535	22.20	165.96
		1/0	2560	23.44	220.80
	16QAM	1/0	2510	21.11	129.12
		1/0	2535	22.41	174.18
		1/0	2560	23.60	229.09

Fundamental Substitution Measurement (Fc > 1GHz)
 UL LLC, Chamber N

Company: SOMC
 Project #: 16J23633D
 Date: 08/01/2016
 Test Engineer: Mark Nolting
 Configuration: Standalone (GSM/UMTS/LTE_Sample)
 Mode: LTE 7, 5M, QPSK

Test Equipment:
 Substitution: Horn antenna AT0078, cable CBL055, and signal-source T374

f MHz	SG reading (dBm)	Ant. Pol. (H/V)	Cable Loss (dB)	Antenna Gain (dBi)	EIRP (dBm)	Limit (dBm)	Margin (dB)	Notes
Low Ch								
2502.50	25.84	V	9.6	5.5	21.78	33.0	-11.2	Pk
2502.50	24.30	H	9.6	5.5	20.24	33.0	-12.8	Pk
Mid Ch								
2535.00	26.70	V	9.6	5.6	22.65	33.0	-10.4	Pk
2535.00	24.41	H	9.6	5.6	20.36	33.0	-12.6	Pk
High Ch								
2567.50	28.18	V	9.7	5.7	24.14	33.0	-8.9	Pk
2567.50	26.29	H	9.7	5.7	22.25	33.0	-10.8	Pk

Rev. 11.02.2015
 Note: For Band 4 EIRP limit is 30dBm

LTE B7 5MHz QPSK

Fundamental Substitution Measurement (Fc > 1GHz)
 UL LLC, Chamber N

Company: SOMC
 Project #: 16J23633D
 Date: 08/01/2016
 Test Engineer: Mark Nolting
 Configuration: Standalone (GSM/UMTS/LTE_Sample)
 Mode: LTE 7, 5M, 16QAM

Test Equipment:
 Substitution: Horn antenna AT0078, cable CBL055, and signal-source T374

f MHz	SG reading (dBm)	Ant. Pol. (H/V)	Cable Loss (dB)	Antenna Gain (dBi)	EIRP (dBm)	Limit (dBm)	Margin (dB)	Notes
Low Ch								
2502.50	25.78	V	9.6	5.5	21.72	33.0	-11.3	Pk
2502.50	24.30	H	9.6	5.5	20.24	33.0	-12.8	Pk
Mid Ch								
2535.00	26.73	V	9.6	5.6	22.68	33.0	-10.3	Pk
2535.00	24.51	H	9.6	5.6	20.46	33.0	-12.5	Pk
High Ch								
2567.50	28.19	V	9.7	5.7	24.16	33.0	-8.8	Pk
2567.50	26.28	H	9.7	5.7	22.25	33.0	-10.8	Pk

Rev. 11.02.2015
 Note: For Band 4 EIRP limit is 30dBm

LTE B7 5MHz 16QAM

Fundamental Substitution Measurement (Fc > 1GHz)
 UL LLC, Chamber N

Company: SOMC
 Project #: 16J23633D
 Date: 08/01/2016
 Test Engineer: Mark Nolting
 Configuration: Standalone (GSM/UMTS/LTE_Sample)
 Mode: LTE 7, 10M, QPSK

Test Equipment:
 Substitution: Horn antenna AT0078, cable CBL055, and signal-source T374

f MHz	SG reading (dBm)	Ant. Pol. (H/V)	Cable Loss (dB)	Antenna Gain (dBi)	EIRP (dBm)	Limit (dBm)	Margin (dB)	Notes
Low Ch								
2505.00	25.51	V	9.6	5.5	21.45	33.0	-11.5	Pk
2505.00	22.85	H	9.6	5.5	18.79	33.0	-14.2	Pk
Mid Ch								
2535.00	26.56	V	9.6	5.6	22.52	33.0	-10.5	Pk
2535.00	24.05	H	9.6	5.6	20.00	33.0	-13.0	Pk
High Ch								
2565.00	27.61	V	9.7	5.7	23.58	33.0	-9.4	Pk
2565.00	24.88	H	9.7	5.7	20.84	33.0	-12.2	Pk

Rev. 11.02.2015
 Note: For Band 4 EIRP limit is 30dBm

LTE B7 10MHz QPSK

Fundamental Substitution Measurement (Fc > 1GHz)
 UL LLC, Chamber N

Company: SOMC
 Project #: 16J23633D
 Date: 08/01/2016
 Test Engineer: Mark Nolting
 Configuration: Standalone (GSM/UMTS/LTE_Sample)
 Mode: LTE 7, 10M, 16QAM

Test Equipment:
 Substitution: Horn antenna AT0078, cable CBL055, and signal-source T374

f MHz	SG reading (dBm)	Ant. Pol. (H/V)	Cable Loss (dB)	Antenna Gain (dBi)	EIRP (dBm)	Limit (dBm)	Margin (dB)	Notes
Low Ch								
2505.00	25.60	V	9.6	5.5	21.54	33.0	-11.5	Pk
2505.00	22.88	H	9.6	5.5	18.82	33.0	-14.2	Pk
Mid Ch								
2535.00	26.62	V	9.6	5.6	22.57	33.0	-10.4	Pk
2535.00	24.07	H	9.6	5.6	20.02	33.0	-13.0	Pk
High Ch								
2565.00	27.80	V	9.7	5.7	23.77	33.0	-9.2	Pk
2565.00	25.06	H	9.7	5.7	21.03	33.0	-12.0	Pk

Rev. 11.02.2015
 Note: For Band 4 EIRP limit is 30dBm

LTE B7 10MHz 16QAM

Fundamental Substitution Measurement (Fc > 1GHz)
 UL LLC, Chamber N

Company: SOMC
 Project #: 16J23633D
 Date: 08/01/2016
 Test Engineer: Mark Nolting
 Configuration: Standalone (GSM/UMTS/LTE_Sample)
 Mode: LTE 7, 15M, QPSK

Test Equipment:
 Substitution: Horn antenna AT0078, cable CBL055, and signal-source T374

f MHz	SG reading (dBm)	Ant. Pol. (H/V)	Cable Loss (dB)	Antenna Gain (dBi)	EIRP (dBm)	Limit (dBm)	Margin (dB)	Notes
Low Ch								
2507.50	24.42	V	9.6	5.5	20.36	33.0	-12.6	Pk
2507.50	24.09	H	9.6	5.5	20.04	33.0	-13.0	Pk
Mid Ch								
2535.00	26.02	V	9.6	5.6	21.97	33.0	-11.0	Pk
2535.00	23.70	H	9.6	5.6	19.65	33.0	-13.4	Pk
High Ch								
2562.50	26.34	V	9.7	5.7	22.31	33.0	-10.7	Pk
2562.50	25.59	H	9.7	5.7	21.55	33.0	-11.4	Pk

Rev. 11.02.2015
 Note: For Band 4 EIRP limit is 30dBm

LTE B7 15MHz QPSK

Fundamental Substitution Measurement (Fc > 1GHz)
 UL LLC, Chamber N

Company: SOMC
 Project #: 16J23633D
 Date: 08/01/2016
 Test Engineer: Mark Nolting
 Configuration: Standalone (GSM/UMTS/LTE_Sample)
 Mode: LTE 7, 15M, 16QAM

Test Equipment:
 Substitution: Horn antenna AT0078, cable CBL055, and signal-source T374

f MHz	SG reading (dBm)	Ant. Pol. (H/V)	Cable Loss (dB)	Antenna Gain (dBi)	EIRP (dBm)	Limit (dBm)	Margin (dB)	Notes
Low Ch								
2507.50	24.54	V	9.6	5.5	20.49	33.0	-12.5	Pk
2507.50	24.22	H	9.6	5.5	20.16	33.0	-12.8	Pk
Mid Ch								
2535.00	26.04	V	9.6	5.6	21.99	33.0	-11.0	Pk
2535.00	23.89	H	9.6	5.6	19.84	33.0	-13.2	Pk
High Ch								
2562.50	26.52	V	9.7	5.7	22.49	33.0	-10.5	Pk
2562.50	25.69	H	9.7	5.7	21.66	33.0	-11.3	Pk

Rev. 11.02.2015
 Note: For Band 4 EIRP limit is 30dBm

LTE B7 15MHz 16QAM

Fundamental Substitution Measurement (Fc > 1GHz) UL LLC, Chamber N								
Company: SOMC Project #: 16J23633D Date: 08/01/2016 Test Engineer: Mark Nolting Configuration: Standalone (GSM/UMTS/LTE_Sample) Mode: LTE 7, 20M, QPSK								
Test Equipment: Substitution: Horn antenna AT0078, cable CBL055, and signal-source T374								
f MHz	SG reading (dBm)	Ant. Pol. (H/V)	Cable Loss (dB)	Antenna Gain (dBi)	EIRP (dBm)	Limit (dBm)	Margin (dB)	Notes
Low Ch								
2510.00	25.13	V	9.6	5.5	21.07	33.0	-11.9	Pk
2510.00	24.02	H	9.6	5.5	19.96	33.0	-13.0	Pk
Mid Ch								
2535.00	26.25	V	9.6	5.6	22.20	33.0	-10.8	Pk
2535.00	23.69	H	9.6	5.6	19.64	33.0	-13.4	Pk
High Ch								
2560.00	27.47	V	9.7	5.7	23.44	33.0	-9.6	Pk
2560.00	25.62	H	9.7	5.7	21.59	33.0	-11.4	Pk
Rev. 11.02.2015 Note: For Band 4 EIRP limit is 30dBm								
LTE B7 20MHz QPSK								

Fundamental Substitution Measurement (Fc > 1GHz) UL LLC, Chamber N								
Company: SOMC Project #: 16J23633D Date: 08/01/2016 Test Engineer: Mark Nolting Configuration: Standalone (GSM/UMTS/LTE_Sample) Mode: LTE 7, 20M, 16QAM								
Test Equipment: Substitution: Horn antenna AT0078, cable CBL055, and signal-source T374								
f MHz	SG reading (dBm)	Ant. Pol. (H/V)	Cable Loss (dB)	Antenna Gain (dBi)	EIRP (dBm)	Limit (dBm)	Margin (dB)	Notes
Low Ch								
2510.00	25.17	V	9.6	5.5	21.11	33.0	-11.9	Pk
2510.00	24.03	H	9.6	5.5	19.98	33.0	-13.0	Pk
Mid Ch								
2535.00	26.46	V	9.6	5.6	22.41	33.0	-10.6	Pk
2535.00	23.77	H	9.6	5.6	19.72	33.0	-13.3	Pk
High Ch								
2560.00	27.63	V	9.7	5.7	23.60	33.0	-9.4	Pk
2560.00	25.88	H	9.7	5.7	21.84	33.0	-11.2	Pk
Rev. 11.02.2015 Note: For Band 4 EIRP limit is 30dBm								
LTE B7 20MHz 16QAM								

LTE Band 41

BW (MHz)	Mode	RB/RB Size	f(MHz)	EIRP (Peak)	
				dBm	mW
5	QPSK	1/0	2498.5	24.09	256.45
		1/0	2593	26.88	487.53
		1/0	2687.5	24.89	308.32
	16QAM	1/0	2498.5	24.11	257.63
		1/0	2593	26.82	480.84
		1/0	2687.5	24.95	312.61
10	QPSK	1/0	2501	24.15	260.02
		1/0	2593	26.74	472.06
		1/0	2685	24.54	284.45
	16QAM	1/0	2501	24.04	253.51
		1/0	2593	26.75	473.15
		1/0	2685	24.56	285.76
15	QPSK	1/0	2503.5	23.97	249.46
		1/0	2593	26.52	448.75
		1/0	2682.5	24.64	291.07
	16QAM	1/0	2503.5	24.09	256.45
		1/0	2593	26.54	450.82
		1/0	2682.5	24.58	287.08
20	QPSK	1/0	2506	24.06	254.68
		1/0	2593	26.75	473.15
		1/0	2680	24.76	299.23
	16QAM	1/0	2506	24.18	261.82
		1/0	2593	26.76	474.24
		1/0	2680	24.86	306.20

Fundamental Substitution Measurement (Fc > 1GHz)
 UL LLC, Chamber N

Company: SOMC
 Project #: 16J23633D
 Date: 08/01/2016
 Test Engineer: Mark Nolting
 Configuration: Standalone (GSM/UMTS/LTE_Sample)
 Mode: LTE 41, 5M, QPSK

Test Equipment:
 Substitution: Horn antenna AT0078, cable CBL055, and signal-source T374

f MHz	SG reading (dBm)	Ant. Pol. (H/V)	Cable Loss (dB)	Antenna Gain (dBi)	EIRP (dBm)	Limit (dBm)	Margin (dB)	Notes
Low Ch								
2498.50	28.15	V	9.6	5.5	24.09	33.0	-8.9	Pk
2498.50	26.69	H	9.6	5.5	22.63	33.0	-10.4	Pk
Mid Ch								
2593.00	30.91	V	9.8	5.8	26.88	33.0	-6.1	Pk
2593.00	29.03	H	9.8	5.8	25.00	33.0	-8.0	Pk
High Ch								
2687.50	28.85	V	10.0	6.0	24.89	33.0	-8.1	Pk
2687.50	26.16	H	10.0	6.0	22.20	33.0	-10.8	Pk

Rev. 11.02.2015
 Note: For Band 4 EIRP limit is 30dBm

LTE B41 5MHz QPSK

Fundamental Substitution Measurement (Fc > 1GHz)
 UL LLC, Chamber N

Company: SOMC
 Project #: 16J23633D
 Date: 08/01/2016
 Test Engineer: Mark Nolting
 Configuration: Standalone (GSM/UMTS/LTE_Sample)
 Mode: LTE 41, 5M, 16QAM

Test Equipment:
 Substitution: Horn antenna AT0078, cable CBL055, and signal-source T374

f MHz	SG reading (dBm)	Ant. Pol. (H/V)	Cable Loss (dB)	Antenna Gain (dBi)	EIRP (dBm)	Limit (dBm)	Margin (dB)	Notes
Low Ch								
2498.50	28.17	V	9.6	5.5	24.11	33.0	-8.9	Pk
2498.50	26.69	H	9.6	5.5	22.63	33.0	-10.4	Pk
Mid Ch								
2593.00	30.85	V	9.8	5.8	26.82	33.0	-6.2	Pk
2593.00	29.09	H	9.8	5.8	25.06	33.0	-7.9	Pk
High Ch								
2687.50	28.91	V	10.0	6.0	24.95	33.0	-8.1	Pk
2687.50	26.20	H	10.0	6.0	22.23	33.0	-10.8	Pk

Rev. 11.02.2015
 Note: For Band 4 EIRP limit is 30dBm

LTE B41 5MHz 16QAM

Fundamental Substitution Measurement (Fc > 1GHz)
 UL LLC, Chamber N

Company: SOMC
 Project #: 16J23633D
 Date: 08/01/2016
 Test Engineer: Mark Nolting
 Configuration: Standalone (GSM/UMTS/LTE_Sample)
 Mode: LTE 41, 10M, QPSK

Test Equipment:
 Substitution: Horn antenna AT0078, cable CBL055, and signal-source T374

f MHz	SG reading (dBm)	Ant. Pol. (H/V)	Cable Loss (dB)	Antenna Gain (dBi)	EIRP (dBm)	Limit (dBm)	Margin (dB)	Notes
Low Ch								
2501.00	28.21	V	9.6	5.5	24.15	33.0	-8.8	Pk
2501.00	26.62	H	9.6	5.5	22.56	33.0	-10.4	Pk
Mid Ch								
2593.00	30.78	V	9.8	5.8	26.74	33.0	-6.3	Pk
2593.00	28.86	H	9.8	5.8	24.82	33.0	-8.2	Pk
High Ch								
2685.00	28.51	V	10.0	6.0	24.54	33.0	-8.5	Pk
2685.00	25.80	H	10.0	6.0	21.84	33.0	-11.2	Pk

Rev. 11.02.2015
 Note: For Band 4 EIRP limit is 30dBm

LTE B41 10MHz QPSK

Fundamental Substitution Measurement (Fc > 1GHz)
 UL LLC, Chamber N

Company: SOMC
 Project #: 16J23633D
 Date: 08/01/2016
 Test Engineer: Mark Nolting
 Configuration: Standalone (GSM/UMTS/LTE_Sample)
 Mode: LTE 41, 10M, 16QAM

Test Equipment:
 Substitution: Horn antenna AT0078, cable CBL055, and signal-source T374

f MHz	SG reading (dBm)	Ant. Pol. (H/V)	Cable Loss (dB)	Antenna Gain (dBi)	EIRP (dBm)	Limit (dBm)	Margin (dB)	Notes
Low Ch								
2501.00	28.10	V	9.6	5.5	24.04	33.0	-9.0	Pk
2501.00	26.54	H	9.6	5.5	22.48	33.0	-10.5	Pk
Mid Ch								
2593.00	30.78	V	9.8	5.8	26.75	33.0	-6.3	Pk
2593.00	28.88	H	9.8	5.8	24.85	33.0	-8.2	Pk
High Ch								
2685.00	28.53	V	10.0	6.0	24.56	33.0	-8.4	Pk
2685.00	25.70	H	10.0	6.0	21.74	33.0	-11.3	Pk

Rev. 11.02.2015
 Note: For Band 4 EIRP limit is 30dBm

LTE B41 10MHz 16QAM

Fundamental Substitution Measurement (Fc > 1GHz)
 UL LLC, Chamber N

Company: SOMC
 Project #: 16J23633D
 Date: 08/01/2016
 Test Engineer: Mark Nolting
 Configuration: Standalone (GSM/UMTS/LTE_Sample)
 Mode: LTE 41, 15M, QPSK

Test Equipment:
 Substitution: Horn antenna AT0078, cable CBL055, and signal-source T374

f MHz	SG reading (dBm)	Ant. Pol. (H/V)	Cable Loss (dB)	Antenna Gain (dBi)	EIRP (dBm)	Limit (dBm)	Margin (dB)	Notes
Low Ch								
2503.50	28.03	V	9.6	5.5	23.97	33.0	-9.0	Pk
2503.50	26.50	H	9.6	5.5	22.45	33.0	-10.6	Pk
Mid Ch								
2593.00	30.56	V	9.8	5.8	26.52	33.0	-6.5	Pk
2593.00	29.01	H	9.8	5.8	24.97	33.0	-8.0	Pk
High Ch								
2682.50	28.61	V	10.0	6.0	24.64	33.0	-8.4	Pk
2682.50	25.88	H	10.0	6.0	21.91	33.0	-11.1	Pk

Rev. 11.02.2015
 Note: For Band 4 EIRP limit is 30dBm

LTE B41 15MHz QPSK

Fundamental Substitution Measurement (Fc > 1GHz)
 UL LLC, Chamber N

Company: SOMC
 Project #: 16J23633D
 Date: 08/01/2016
 Test Engineer: Mark Nolting
 Configuration: Standalone (GSM/UMTS/LTE_Sample)
 Mode: LTE 41, 15M, 16QAM

Test Equipment:
 Substitution: Horn antenna AT0078, cable CBL055, and signal-source T374

f MHz	SG reading (dBm)	Ant. Pol. (H/V)	Cable Loss (dB)	Antenna Gain (dBi)	EIRP (dBm)	Limit (dBm)	Margin (dB)	Notes
Low Ch								
2503.50	28.15	V	9.6	5.5	24.09	33.0	-8.9	Pk
2503.50	26.60	H	9.6	5.5	22.54	33.0	-10.5	Pk
Mid Ch								
2593.00	30.58	V	9.8	5.8	26.54	33.0	-6.5	Pk
2593.00	29.19	H	9.8	5.8	25.16	33.0	-7.8	Pk
High Ch								
2682.50	28.54	V	10.0	6.0	24.58	33.0	-8.4	Pk
2682.50	25.98	H	10.0	6.0	22.01	33.0	-11.0	Pk

Rev. 11.02.2015
 Note: For Band 4 EIRP limit is 30dBm

LTE B41 15MHz 16QAM

Fundamental Substitution Measurement (Fc > 1GHz) UL LLC, Chamber N								
Company: SOMC Project #: 16J23633D Date: 08/01/2016 Test Engineer: Mark Nolting Configuration: Standalone (GSM/UMTS/LTE_Sample) Mode: LTE 41, 20M, QPSK								
Test Equipment: Substitution: Horn antenna AT0078, cable CBL055, and signal-source T374								
f MHz	SG reading (dBm)	Ant. Pol. (H/V)	Cable Loss (dB)	Antenna Gain (dBi)	EIRP (dBm)	Limit (dBm)	Margin (dB)	Notes
Low Ch								
2506.00	28.12	V	9.6	5.5	24.06	33.0	-8.9	Pk
2506.00	26.56	H	9.6	5.5	22.50	33.0	-10.5	Pk
Mid Ch								
2593.00	30.78	V	9.8	5.8	26.75	33.0	-6.2	Pk
2593.00	29.10	H	9.8	5.8	25.07	33.0	-7.9	Pk
High Ch								
2680.00	28.72	V	10.0	6.0	24.76	33.0	-8.2	Pk
2680.00	25.99	H	10.0	6.0	22.02	33.0	-11.0	Pk
Rev. 11.02.2015 Note: For Band 4 EIRP limit is 30dBm								
LTE B41 20MHz QPSK								

Fundamental Substitution Measurement (Fc > 1GHz) UL LLC, Chamber N								
Company: SOMC Project #: 16J23633D Date: 08/01/2016 Test Engineer: Mark Nolting Configuration: Standalone (GSM/UMTS/LTE_Sample) Mode: LTE 41, 20M, 16QAM								
Test Equipment: Substitution: Horn antenna AT0078, cable CBL055, and signal-source T374								
f MHz	SG reading (dBm)	Ant. Pol. (H/V)	Cable Loss (dB)	Antenna Gain (dBi)	EIRP (dBm)	Limit (dBm)	Margin (dB)	Notes
Low Ch								
2506.00	28.24	V	9.6	5.5	24.18	33.0	-8.8	Pk
2506.00	26.72	H	9.6	5.5	22.67	33.0	-10.3	Pk
Mid Ch								
2593.00	30.79	V	9.8	5.8	26.76	33.0	-6.2	Pk
2593.00	29.14	H	9.8	5.8	25.11	33.0	-7.9	Pk
High Ch								
2680.00	28.83	V	10.0	6.0	24.86	33.0	-8.1	Pk
2680.00	26.12	H	10.0	6.0	22.15	33.0	-10.8	Pk
Rev. 11.02.2015 Note: For Band 4 EIRP limit is 30dBm								
LTE B41 20MHz 16QAM								

7.2. FIELD STRENGTH OF SPURIOUS RADIATION

RULE PART(S)

FCC: §27.53

LIMIT

Part 27: (m)(4) (4) For mobile digital stations, the attenuation factor shall be not less than $40 + 10 \log (P)$ dB on all frequencies between the Channel edge and 5 megahertz from the Channel edge, $43 + 10 \log (P)$ dB on all frequencies between 5 megahertz and X megahertz from the Channel edge, and $55 + 10 \log (P)$ dB on all frequencies more than X megahertz from the Channel edge, where X is the greater of 6 megahertz or the actual emission bandwidth as defined in paragraph (m)(6) of this section. In addition, the attenuation factor shall not be less than $43 + 10 \log (P)$ dB on all frequencies between 2490.5 MHz and 2496 MHz and $55 + 10 \log (P)$ dB at or below 2490.5 MHz. Mobile Satellite Service licensees operating on frequencies below 2495 MHz may also submit a documented interference complaint against BRS licensees operating on Channel BRS Channel 1 on the same terms and conditions as adjacent Channel BRS or EBS licensees.

TEST PROCEDURE

For Cellular equipment - Compliance with these rules is based on the use of measurement instrumentation employing a resolution bandwidth of 100 kHz or greater. In the 1 MHz bands immediately outside and adjacent to the frequency block a resolution bandwidth of at least one percent of the emission bandwidth of the fundamental emission of the transmitter may be employed. A narrower resolution bandwidth is permitted in all cases to improve measurement accuracy provided the measured power is integrated over the full required measurement bandwidth (i.e. 100 kHz or 1 percent of emission bandwidth, as specified). The emission bandwidth is defined as the width of the signal between two points, one below the carrier center frequency and one above the carrier center frequency, outside of which all emissions are attenuated at least 26 dB below the transmitter power.

For PCS equipment - Compliance with these rules is based on the use of measurement instrumentation employing a resolution bandwidth of 1 MHz or greater. However, in the 1 MHz bands immediately outside and adjacent to the frequency block a resolution bandwidth of at least one percent of the emission bandwidth of the fundamental emission of the transmitter may be employed. A narrower resolution bandwidth is permitted in all cases to improve measurement accuracy provided the measured power is integrated over the full required measurement bandwidth (i.e. 1 MHz or 1 percent of emission bandwidth, as specified). The emission bandwidth is defined as the width of the signal between two points, one below the carrier center frequency and one above the carrier center frequency, outside of which all emissions are attenuated at least 26 dB below the transmitter power.

**High Frequency Substitution Measurement
 UL RTP Radiated Chamber**

Company: SOMC
 Project #: 16J23633D
 Date: 08/02/2016
 Test Engineer: Brian Kievra / John Manser
 Configuration: Unit with ear-buds and charger (GSM/UMTS/LTE_Sample)
 Mode: LTE Band 7, 15MHz QPSK

Test Equipment:
 Substitution: Horn AT0078 Substitution, and CBL010 SMA Cable

Chamber		Pre-amplifier		Filter		Limit	
3m Chamber N-RTP		3m Chamber N-RTP		Filter		LTE B7	

Frequency (GHz)	SA reading (dBm)	Ant. Pol. (HV)	Distance	EIRP @ TX Ant End (dBm)	Preamp	Attenuator	EIRP	Limit	Delta	Notes
Low Channel (2507.5MHz)										
5.02	-51.1	H	3.0	-2.4	40.3	1.0	-41.7	-25.0	-16.7	
7.52	-51.7	H	3.0	-1.2	38.9	1.0	-39.2	-25.0	-14.2	
10.03	-58.4	H	3.0	0.8	38.3	1.0	-36.6	-25.0	-11.6	
5.02	-55.1	V	3.0	-2.6	40.3	1.0	-41.8	-25.0	-16.9	
7.52	-51.7	V	3.0	-1.5	38.9	1.0	-39.4	-25.0	-14.4	
10.03	-58.4	V	3.0	0.8	38.3	1.0	-36.5	-25.0	-11.5	
Mid Channel (2535MHz)										
5.07	-54.9	H	3.0	-2.1	40.3	1.0	-41.4	-25.0	-16.4	
7.61	-51.1	H	3.0	-0.5	38.9	1.0	-38.4	-25.0	-13.4	
10.14	-58.1	H	3.0	1.3	38.3	1.0	-36.1	-25.0	-11.1	
5.07	-54.9	V	3.0	-2.2	40.3	1.0	-41.5	-25.0	-16.5	
7.61	-51.3	V	3.0	-0.9	38.9	1.0	-38.8	-25.0	-13.8	
10.14	-58.0	V	3.0	1.3	38.3	1.0	-36.0	-25.0	-11.0	
High Channel (2562.5MHz)										
5.13	-55.7	H	3.0	-2.8	40.3	1.0	-42.1	-25.0	-17.1	
7.69	-51.2	H	3.0	-0.5	38.9	1.0	-38.4	-25.0	-13.4	
10.25	-57.8	H	3.0	1.7	38.3	1.0	-35.8	-25.0	-10.8	
5.13	-55.7	V	3.0	-2.9	40.3	1.0	-42.3	-25.0	-17.3	
7.69	-51.2	V	3.0	-0.7	38.9	1.0	-38.6	-25.0	-13.6	
10.25	-57.8	V	3.0	1.6	38.3	1.0	-35.7	-25.0	-10.7	

Rev: 10.28.15

LTE B7 15MHz QPSK

**High Frequency Substitution Measurement
 UL RTP Radiated Chamber**

Company: SOMC
 Project #: 16J23633D
 Date: 08/02/2016
 Test Engineer: Brian Kievra / John Manser
 Configuration: Unit with ear-buds and charger (GSM/UMTS/LTE_Sample)
 Mode: LTE Band 7, 15MHz 16QAM

Test Equipment:
 Substitution: Horn AT0078 Substitution, and CBL010 SMA Cable

Chamber		Pre-amplifier		Filter		Limit	
3m Chamber N-RTP		3m Chamber N-RTP		Filter		LTE B7	

Frequency (GHz)	SA reading (dBm)	Ant. Pol. (HV)	Distance	EIRP @ TX Ant End (dBm)	Preamp	Attenuator	EIRP	Limit	Delta	Notes
Low Channel (2507.5MHz)										
5.02	-51.1	H	3.0	-2.4	40.3	1.0	-41.7	-25.0	-16.7	
7.52	-51.8	H	3.0	-1.3	38.9	1.0	-39.3	-25.0	-14.3	
10.03	-58.4	H	3.0	0.8	38.3	1.0	-36.6	-25.0	-11.6	
5.02	-55.1	V	3.0	-2.6	40.3	1.0	-41.8	-25.0	-16.8	
7.52	-51.8	V	3.0	-1.6	38.9	1.0	-39.5	-25.0	-14.5	
10.03	-58.4	V	3.0	0.8	38.3	1.0	-36.5	-25.0	-11.5	
Mid Channel (2535MHz)										
5.07	-54.8	H	3.0	-2.1	40.3	1.0	-41.4	-25.0	-16.4	
7.61	-51.1	H	3.0	-0.5	38.9	1.0	-38.5	-25.0	-13.5	
10.14	-51.9	H	3.0	1.4	38.3	1.0	-35.9	-25.0	-10.9	
5.07	-54.9	V	3.0	-2.3	40.3	1.0	-41.6	-25.0	-16.6	
7.61	-51.1	V	3.0	-0.8	38.9	1.0	-38.7	-25.0	-13.7	
10.14	-51.9	V	3.0	1.4	38.3	1.0	-35.9	-25.0	-10.9	
High Channel (2562.5MHz)										
5.13	-55.5	H	3.0	-2.7	40.3	1.0	-42.0	-25.0	-17.0	
7.69	-51.2	H	3.0	-0.5	38.9	1.0	-38.4	-25.0	-13.4	
10.25	-57.8	H	3.0	1.7	38.3	1.0	-35.7	-25.0	-10.7	
5.13	-55.6	V	3.0	-2.9	40.3	1.0	-42.2	-25.0	-17.2	
7.69	-51.1	V	3.0	-0.7	38.9	1.0	-38.6	-25.0	-13.6	
10.25	-57.9	V	3.0	1.6	38.3	1.0	-35.7	-25.0	-10.7	

Rev: 10.28.15

LTE B7 15MHz 16QAM

**High Frequency Substitution Measurement
 UL RTP Radiated Chamber**

Company: SOMC
 Project #: 16J23633D
 Date: 08/02/2016
 Test Engineer: Brian Kievra / John Manser
 Configuration: Unit with ear-buds and charger (GSM/UMTS/LTE_Sample)
 Mode: LTE Band 7, 20MHz QPSK

Test Equipment:
 Substitution: Horn AT0078 Substitution, and CBL010 SMA Cable

Chamber		Pre-amplifier		Filter		Limit	
3m Chamber N-RTP		3m Chamber N-RTP		Filter		LTE B7	

Frequency (GHz)	SA reading (dBm)	Ant. Pol. (HV)	Distance	EIRP @ TX Ant End (dBm)	Preamp	Attenuator	EIRP	Limit	Delta	Notes
Low Channel (2510MHz)										
5.02	-53.7	H	3.0	-1.8	40.3	1.0	-40.3	-25.0	-15.3	
7.53	-56.5	H	3.0	0.0	38.9	1.0	-37.9	-25.0	-12.9	
10.04	-51.2	H	3.0	2.0	38.3	1.0	-35.3	-25.0	-10.3	
5.02	-53.6	V	3.0	-1.1	40.3	1.0	-40.3	-25.0	-15.3	
7.53	-56.4	V	3.0	-0.2	38.9	1.0	-38.1	-25.0	-13.1	
10.04	-51.1	V	3.0	2.2	38.3	1.0	-35.1	-25.0	-10.1	
Mid Channel (2535MHz)										
5.07	-53.5	H	3.0	-0.8	40.3	1.0	-40.0	-25.0	-15.0	
7.61	-55.8	H	3.0	0.8	38.9	1.0	-37.1	-25.0	-12.1	
10.14	-56.7	H	3.0	2.7	38.3	1.0	-34.6	-25.0	-9.6	
5.07	-53.4	V	3.0	-0.7	40.3	1.0	-40.0	-25.0	-15.0	
7.61	-55.8	V	3.0	0.9	38.9	1.0	-37.4	-25.0	-12.4	
10.14	-56.7	V	3.0	2.7	38.3	1.0	-34.7	-25.0	-9.7	
High Channel (2560MHz)										
5.12	-54.2	H	3.0	-1.4	40.3	1.0	-40.7	-25.0	-15.7	
7.68	-55.9	H	3.0	0.8	38.9	1.0	-37.1	-25.0	-12.1	
10.24	-56.5	H	3.0	3.0	38.3	1.0	-34.3	-25.0	-9.3	
5.12	-54.2	V	3.0	-1.5	40.3	1.0	-40.8	-25.0	-15.8	
7.68	-55.8	V	3.0	0.6	38.9	1.0	-37.3	-25.0	-12.3	
10.24	-56.4	V	3.0	3.1	38.3	1.0	-34.2	-25.0	-9.2	

Rev: 10.28.15

LTE B7 20MHz QPSK

**High Frequency Substitution Measurement
 UL RTP Radiated Chamber**

Company: SOMC
 Project #: 16J23633D
 Date: 08/02/2016
 Test Engineer: Brian Kievra / John Manser
 Configuration: Unit with ear-buds and charger (GSM/UMTS/LTE_Sample)
 Mode: LTE Band 7, 20MHz 16QAM

Test Equipment:
 Substitution: Horn AT0078 Substitution, and CBL010 SMA Cable

Chamber		Pre-amplifier		Filter		Limit	
3m Chamber N-RTP		3m Chamber N-RTP		Filter		LTE B7	

Frequency (GHz)	SA reading (dBm)	Ant. Pol. (HV)	Distance	EIRP @ TX Ant End (dBm)	Preamp	Attenuator	EIRP	Limit	Delta	Notes
Low Channel (2510MHz)										
5.02	-53.5	H	3.0	-0.9	40.3	1.0	-40.2	-25.0	-15.2	
7.53	-56.5	H	3.0	0.0	38.9	1.0	-37.9	-25.0	-12.9	
10.04	-51.1	H	3.0	2.1	38.3	1.0	-35.2	-25.0	-10.2	
5.02	-53.5	V	3.0	-0.9	40.3	1.0	-40.2	-25.0	-15.2	
7.53	-56.4	V	3.0	-0.1	38.9	1.0	-38.0	-25.0	-13.0	
10.04	-51.1	V	3.0	2.2	38.3	1.0	-35.1	-25.0	-10.1	
Mid Channel (2535MHz)										
5.07	-53.4	H	3.0	-0.6	40.3	1.0	-39.9	-25.0	-14.9	
7.61	-55.8	H	3.0	0.8	38.9	1.0	-37.1	-25.0	-12.1	
10.14	-56.6	H	3.0	2.7	38.3	1.0	-34.6	-25.0	-9.6	
5.07	-53.3	V	3.0	-0.7	40.3	1.0	-40.0	-25.0	-15.0	
7.61	-55.8	V	3.0	0.5	38.9	1.0	-37.4	-25.0	-12.4	
10.14	-56.7	V	3.0	2.7	38.3	1.0	-34.6	-25.0	-9.6	
High Channel (2560MHz)										
5.12	-54.2	H	3.0	-1.4	40.3	1.0	-40.7	-25.0	-15.7	
7.68	-55.8	H	3.0	0.9	38.9	1.0	-37.0	-25.0	-12.0	
10.24	-56.5	H	3.0	2.9	38.3	1.0	-34.4	-25.0	-9.4	
5.12	-54.1	V	3.0	-1.4	40.3	1.0	-40.7	-25.0	-15.7	
7.68	-55.8	V	3.0	0.6	38.9	1.0	-37.3	-25.0	-12.3	
10.24	-56.4	V	3.0	3.1	38.3	1.0	-34.3	-25.0	-9.3	

Rev: 10.28.15

LTE B7 20MHz 16QAM

LTE Band 41

High Frequency Substitution Measurement
UL RTP Radiated Chamber

Company: SOMC
 Project #: 16J23633D
 Date: 08/03/2016
 Test Engineer: Mark Nolting
 Configuration: Unit with ear-buds and charger (GSMUMTS/LTE_Sample)
 Mode: LTE Band 41, 5MHz QPSK

Test Equipment:
 Substitution: Horn AT0078 Substitution, and CBL010 SMA Cable

Chamber	Pre-amplifier	Filter	Limit
3m Chamber N-RTP	3m Chamber N-RTP	Filter	LTE B41

Frequency (GHz)	SA reading (dBm)	Ant. Pol. (H/V)	Distance	EIRP @ TX Ant End (dBm)	Preamp	Attenuator	EIRP	Limit	Delta	Notes
Low Channel (2498.5MHz)										
5.00	61.8	H	3.0	9.2	40.3	1.0	-48.4	-25.0	-23.4	
7.50	66.1	H	3.0	-3.6	38.9	1.0	-47.6	-25.0	-22.6	
9.99	66.9	H	3.0	-7.7	38.3	1.0	-45.1	-25.0	-26.1	
Mid Channel (2593MHz)										
5.00	62.4	V	3.0	-8.8	40.3	1.0	-49.1	-25.0	-24.1	
7.50	66.4	V	3.0	-19.2	38.9	1.0	-48.1	-25.0	-23.1	
9.99	67.1	V	3.0	-7.9	38.3	1.0	-45.2	-25.0	-26.2	
High Channel (2687.5MHz)										
5.38	60.7	H	3.0	-7.5	40.2	1.0	-46.7	-25.0	-21.7	
8.06	66.3	H	3.0	-9.2	38.8	1.0	-47.0	-25.0	-22.0	
10.75	67.2	H	3.0	-7.1	38.3	1.0	-44.4	-25.0	-19.4	
Low Channel (2498.5MHz)										
5.00	62.6	V	3.0	-9.5	40.2	1.0	-48.7	-25.0	-23.7	
7.50	66.9	V	3.0	-9.1	38.8	1.0	-46.9	-25.0	-21.9	
10.75	67.7	V	3.0	-7.7	38.3	1.0	-45.1	-25.0	-26.1	

Rev: 10.28.15

LTE B41 5MHz QPSK

High Frequency Substitution Measurement
UL RTP Radiated Chamber

Company: SOMC
 Project #: 16J23633D
 Date: 08/03/2016
 Test Engineer: Mark Nolting
 Configuration: Unit with ear-buds and charger (GSMUMTS/LTE_Sample)
 Mode: LTE Band 41, 5MHz 16QAM

Test Equipment:
 Substitution: Horn AT0078 Substitution, and CBL010 SMA Cable

Chamber	Pre-amplifier	Filter	Limit
3m Chamber N-RTP	3m Chamber N-RTP	Filter	LTE B41

Frequency (GHz)	SA reading (dBm)	Ant. Pol. (H/V)	Distance	EIRP @ TX Ant End (dBm)	Preamp	Attenuator	EIRP	Limit	Delta	Notes
Low Channel (2498.5MHz)										
5.00	62.0	H	3.0	-9.4	40.3	1.0	-48.7	-25.0	-23.7	
7.50	66.4	H	3.0	-9.9	38.9	1.0	-47.9	-25.0	-22.9	
9.99	66.9	H	3.0	-7.7	38.3	1.0	-45.1	-25.0	-26.1	
Mid Channel (2593MHz)										
5.00	62.2	V	3.0	-9.7	40.3	1.0	-48.9	-25.0	-23.9	
7.50	66.9	V	3.0	-10.7	38.9	1.0	-48.6	-25.0	-23.6	
9.99	66.9	V	3.0	-7.7	38.3	1.0	-45.0	-25.0	-26.0	
High Channel (2687.5MHz)										
5.38	60.7	H	3.0	-8.8	40.3	1.0	-46.1	-25.0	-21.1	
7.78	66.1	H	3.0	-9.3	38.9	1.0	-47.2	-25.0	-22.2	
10.37	67.3	H	3.0	-7.7	38.3	1.0	-45.0	-25.0	-26.0	
Low Channel (2498.5MHz)										
5.00	62.5	V	3.0	-9.5	40.2	1.0	-48.9	-25.0	-23.9	
7.78	66.1	V	3.0	-9.5	38.9	1.0	-47.4	-25.0	-22.4	
10.37	67.1	V	3.0	-7.5	38.3	1.0	-44.8	-25.0	-19.8	
High Channel (2687.5MHz)										
5.38	62.6	V	3.0	-9.5	40.2	1.0	-48.7	-25.0	-23.7	
8.06	66.2	V	3.0	-9.3	38.8	1.0	-47.1	-25.0	-22.1	
10.75	68.0	V	3.0	-8.0	38.3	1.0	-45.3	-25.0	-26.3	

Rev: 10.28.15

LTE B41 5MHz 16QAM

High Frequency Substitution Measurement
UL RTP Radiated Chamber

Company: SOMC
 Project #: 16J23633D
 Date: 08/03/2016
 Test Engineer: Mark Nolting
 Configuration: Unit with ear-buds and charger (GSMUMTS/LTE_Sample)
 Mode: LTE Band 41, 10MHz QPSK

Test Equipment:
 Substitution: Horn AT0078 Substitution, and CBL010 SMA Cable

Chamber	Pre-amplifier	Filter	Limit
3m Chamber N-RTP	3m Chamber N-RTP	Filter	LTE B41

Frequency (GHz)	SA reading (dBm)	Ant. Pol. (H/V)	Distance	EIRP @ TX Ant End (dBm)	Preamp	Attenuator	EIRP	Limit	Delta	Notes
Low Channel (2498.5MHz)										
5.00	62.1	H	3.0	-9.5	40.3	1.0	-48.7	-25.0	-23.7	
7.50	66.6	H	3.0	-19.3	38.9	1.0	-48.3	-25.0	-23.3	
10.00	67.1	H	3.0	-7.8	38.3	1.0	-45.3	-25.0	-26.3	
Mid Channel (2593MHz)										
5.00	62.6	V	3.0	-10.0	40.3	1.0	-49.3	-25.0	-24.3	
7.50	66.5	V	3.0	-9.9	38.9	1.0	-47.8	-25.0	-22.8	
10.00	67.6	V	3.0	-7.8	38.3	1.0	-45.1	-25.0	-26.1	
High Channel (2687.5MHz)										
5.19	59.5	H	3.0	-6.6	40.3	1.0	-45.9	-25.0	-20.9	
7.78	65.5	H	3.0	-8.8	38.9	1.0	-46.6	-25.0	-21.6	
10.37	67.5	H	3.0	-7.9	38.3	1.0	-45.2	-25.0	-26.2	
Low Channel (2498.5MHz)										
5.19	59.9	V	3.0	-7.1	40.3	1.0	-46.4	-25.0	-21.4	
7.78	65.9	V	3.0	-9.3	38.9	1.0	-47.2	-25.0	-22.2	
10.37	67.6	V	3.0	-7.4	38.3	1.0	-44.8	-25.0	-19.8	
High Channel (2687.5MHz)										
5.37	59.8	H	3.0	-6.5	40.2	1.0	-45.7	-25.0	-20.7	
8.06	65.8	H	3.0	-8.8	38.8	1.0	-46.6	-25.0	-21.6	
10.74	67.3	H	3.0	-7.3	38.3	1.0	-44.6	-25.0	-19.6	
Low Channel (2498.5MHz)										
5.37	62.5	V	3.0	-9.4	40.2	1.0	-48.7	-25.0	-23.7	
8.06	66.5	V	3.0	-10.0	38.8	1.0	-47.8	-25.0	-22.8	
10.74	66.5	V	3.0	-6.5	38.3	1.0	-43.8	-25.0	-18.8	

Rev: 10.28.15

LTE B41 10MHz QPSK

High Frequency Substitution Measurement
UL RTP Radiated Chamber

Company: SOMC
 Project #: 16J23633D
 Date: 08/03/2016
 Test Engineer: Mark Nolting
 Configuration: Unit with ear-buds and charger (GSMUMTS/LTE_Sample)
 Mode: LTE Band 41, 10MHz 16QAM

Test Equipment:
 Substitution: Horn AT0078 Substitution, and CBL010 SMA Cable

Chamber	Pre-amplifier	Filter	Limit
3m Chamber N-RTP	3m Chamber N-RTP	Filter	LTE B41

Frequency (GHz)	SA reading (dBm)	Ant. Pol. (H/V)	Distance	EIRP @ TX Ant End (dBm)	Preamp	Attenuator	EIRP	Limit	Delta	Notes
Low Channel (2498.5MHz)										
5.00	61.7	H	3.0	-9.1	40.3	1.0	-48.3	-25.0	-23.3	
7.50	66.4	H	3.0	-9.9	38.9	1.0	-47.8	-25.0	-22.8	
10.00	67.1	H	3.0	-8.0	38.3	1.0	-45.3	-25.0	-26.3	
Mid Channel (2593MHz)										
5.00	62.5	V	3.0	-9.9	40.3	1.0	-49.2	-25.0	-24.2	
7.50	66.5	V	3.0	-9.3	38.9	1.0	-47.3	-25.0	-22.3	
10.00	66.5	V	3.0	-7.3	38.3	1.0	-44.6	-25.0	-19.6	
High Channel (2687.5MHz)										
5.19	59.2	H	3.0	-6.3	40.3	1.0	-45.7	-25.0	-20.7	
7.78	66.9	H	3.0	-9.2	38.9	1.0	-47.1	-25.0	-22.1	
10.37	67.5	H	3.0	-7.9	38.3	1.0	-45.2	-25.0	-26.2	
Low Channel (2498.5MHz)										
5.19	60.1	V	3.0	-7.3	40.3	1.0	-46.6	-25.0	-21.6	
7.78	65.9	V	3.0	-9.3	38.9	1.0	-47.2	-25.0	-22.2	
10.37	67.8	V	3.0	-8.2	38.3	1.0	-45.5	-25.0	-26.5	
High Channel (2687.5MHz)										
5.37	60.2	H	3.0	-6.9	40.2	1.0	-46.1	-25.0	-21.1	
8.06	65.9	H	3.0	-7.9	38.8	1.0	-45.7	-25.0	-20.7	
10.74	67.7	H	3.0	-7.8	38.3	1.0	-44.9	-25.0	-19.9	
Low Channel (2498.5MHz)										
5.37	62.4	V	3.0	-9.3	40.2	1.0	-48.5	-25.0	-23.5	
8.06	66.4	V	3.0	-9.5	38.8	1.0	-47.3	-25.0	-22.3	
10.74	67.9	V	3.0	-7.9	38.3	1.0	-45.3	-25.0	-26.3	

Rev: 10.28.15

LTE B41 10MHz 16QAM

