



CERTIFICATION TEST REPORT

Report Number. : 11783639-E1V3

Applicant : SONY MOBILE COMMUNICATIONS INC.
4-12-3 HIGASHI-SHINAGAWA,
SHINAGAWA -KU,TOKYO, 140-0002, JAPAN

FCC ID : PY7-88607S

EUT Description : GSM/WCDMA/LTE Phone with BT,DTS/UNII a/b/g/n/ac, GPS & NFC

Test Standard(s) : FCC CFR47 PART 22 SUBPART H
FCC CFR47 PART 24 SUBPART E
FCC CFR47 PART 27 SUBPART F, H, L, and M

Date Of Issue:

August 10, 2017

Prepared by:

UL Verification Services Inc.
47173 Benicia Street
Fremont, CA 94538, U.S.A.
TEL: (510) 771-1000
FAX: (510) 661-0888



NVLAP LAB CODE 200065-0

Revision History

| <u>Rev.</u> | <u>Issue Date</u> | <u>Revisions</u> | <u>Revised By</u> |
|-------------|-------------------|--|-------------------|
| V1 | 08/03/17 | Initial Issue | D. Corona |
| V2 | 08/08/17 | Updated Section 11.8 & added Section 6 | D. Corona |
| V3 | 08/10/17 | Updated Section 14.1, 16.1 and added Section 6.2 & 6.3 | D. Corona |

TABLE OF CONTENTS

1. ATTESTATION OF TEST RESULTS5

2. TEST METHODOLOGY 6

3. FACILITIES AND ACCREDITATION6

4. CALIBRATION AND UNCERTAINTY 6

 4.1. MEASURING INSTRUMENT CALIBRATION 6

 4.2. SAMPLE CALCULATION 6

 4.3. MEASUREMENT UNCERTAINTY 7

5. EQUIPMENT UNDER TEST8

 5.1. DESCRIPTION OF EUT 8

6. REUSE OF TEST DATA..... 9

 6.1. EQUIPMENT UNDER TEST 9

 6.2. VERIFICATION RESULTS SUMMARY 9

 6.3. REFERENCE DETAIL 9

7. MAXIMUM OUTPUT POWER 10

 7.1. MAXIMUM OUTPUT POWER (GSM/EGPRS)..... 10

 7.2. MAXIMUM OUTPUT POWER (WCDMA)..... 11

 7.3. MAXIMUM OUTPUT POWER (LTE)..... 12

8. DESCRIPTION OF AVAILABLE ANTENNAS 15

9. DESCRIPTION OF TEST SETUP 16

10. TEST AND MEASUREMENT EQUIPMENT 19

11. SUMMARY TABLE.....20

12. RF POWER OUTPUT VERIFICATION.....21

 12.1. GSM/GPRS/EDGE22

 12.2. GSM OUTPUT POWER RESULT23

 12.3. UMTS REL 99.....25

 12.4. UMTS REL 99 OUTPUT POWER RESULT26

 12.5. UMTS HSDPA27

 12.6. UMTS HSDPA OUTPUT POWER RESULT28

 12.7. UMTS HSUPA29

 12.8. UMTS HSUPA OUTPUT POWER RESULT30

 12.9. LTE OUTPUT POWER RESULT31

13. PEAK TO AVERAGE RATIO 70

| | | |
|------------|---|------------|
| 13.1. | CONDUCTED PEAK TO AVERAGE RESULT | 71 |
| 14. | OCCUPIED BANDWIDTH | 79 |
| 14.1. | OCCUPIED BANDWIDTH RESULTS AND PLOTS | 80 |
| 15. | BAND EDGE EMISSIONS..... | 95 |
| 15.1. | BAND EDGE PLOTS..... | 96 |
| 15.2. | EMISSION MASK PLOTS | 114 |
| 16. | OUT OF BAND EMISSIONS | 120 |
| 16.1. | OUT OF BAND EMISSIONS RESULT AND PLOTS..... | 121 |
| 18. | FREQUENCY STABILITY | 136 |
| 18.1. | FREQUENCY STABILITY RESULTS..... | 137 |
| 19. | RADIATED TEST RESULTS..... | 138 |
| 19.1. | FIELD STRENGTH OF SPURIOUS RADIATION..... | 138 |
| 19.1.1. | SPURIOUS RADIATION PLOTS..... | 139 |
| 20. | SETUP PHOTOS | 149 |

1. ATTESTATION OF TEST RESULTS

COMPANY NAME: SONY MOBILE COMMUNICATIONS, INC.
4-12-3 HIGASHI-SHINAGAWA,
SHINAGAWA –KU, TOKYO, 140-0002, JAPAN

EUT DESCRIPTION: GSM/WCDMA/LTE PHONE with BT, DTS/UNII a/b/g/n/ac, GPS & NFC

SERIAL NUMBER: BH90004K83, BH9000KF83 (Condcuted)
BH9000F983, BH9000G283(Radaited)

DATE TESTED: July 8 – 21, 2017

| APPLICABLE STANDARDS | |
|---------------------------------------|--------------|
| STANDARD | TEST RESULTS |
| FCC PART 22H, 24E, 27H, 27F, 27L, 27M | PASS |

UL Verification Services Inc. tested the above equipment in accordance with the requirements set forth in the above standards. All indications of Pass/Fail in this report are opinions expressed by UL Verification Services Inc. based on interpretations and/or observations of test results. Measurement Uncertainties were not taken into account and are published for informational purposes only. The test results show that the equipment tested is capable of demonstrating compliance with the requirements as documented in this report.

Note: The results documented in this report apply only to the tested sample, under the conditions and modes of operation as described herein. This document may not be altered or revised in any way unless done so by UL Verification Services Inc. and all revisions are duly noted in the revisions section. Any alteration of this document not carried out by UL Verification Services Inc. will constitute fraud and shall nullify the document. This report must not be used by the client to claim product certification, approval, or endorsement by NVLAP, NIST, any agency of the Federal Government, or any agency of any government.

Approved & Released For
UL Verification Services Inc. By:

Prepared By:



DAN CORONIA
CONSUMER TECHNOLOGY DIVISION
WISE PROJECT LEAD
UL VERIFICATION SERVICES INC

KIYA KEDIDA
CONSUMER TECHNOLOGY DIVISION
WISE LAB ENGINEER
UL VERIFICATION SERVICES INC

2. TEST METHODOLOGY

The tests documented in this report were performed in accordance with TIA-603-D, FCC CFR 47 Part 2, FCC KDB 971168 D01 v02r02, Part 22, Part 24, and Part 27.

3. FACILITIES AND ACCREDITATION

The test sites and measurement facilities used to collect data are located at 47173 and 47266 Benicia Street, Fremont, California, USA. Line conducted emissions are measured only at the 47173 address. The following table identifies which facilities were utilized for radiated emission measurements documented in this report. Specific facilities are also identified in the test results sections.

| 47173 Benicia Street | 47266 Benicia Street |
|--|---|
| <input type="checkbox"/> Chamber A(IC: 2324B-1) | <input type="checkbox"/> Chamber D(IC: 22541-1) |
| <input type="checkbox"/> Chamber B(IC: 2324B-2) | <input type="checkbox"/> Chamber E(IC: 22541-2) |
| <input checked="" type="checkbox"/> Chamber C(IC: 2324B-3) | <input type="checkbox"/> Chamber F(IC: 22541-3) |
| | <input type="checkbox"/> Chamber G(IC: 22541-4) |
| | <input type="checkbox"/> Chamber H(IC: 22541-5) |

The above test sites and facilities are covered under FCC Test Firm Registration # 208313. UL Verification Services Inc. is accredited by NVLAP, Laboratory Code 200065-0. Chambers A through C are covered under Industry Canada company address code 2324B with site numbers 2324B -1 through 2324B-3, respectively. Chambers D through H are covered under Industry Canada company address code 22541 with site numbers 22541 -1 through 22541-5, respectively.

4. CALIBRATION AND UNCERTAINTY

4.1. MEASURING INSTRUMENT CALIBRATION

The measuring equipment utilized to perform the tests documented in this report has been calibrated in accordance with the manufacturer's recommendations, and is traceable to recognized national standards

4.2. SAMPLE CALCULATION

Where relevant, the following sample calculation is provided:

$EIRP = \text{PSA reading with EUT worst orientation (dBm)} + \text{Path loss (dB)} - \text{cable loss (between the SG and substitution antenna)} + \text{Substitution Antenna Factor (dBi)}$

$ERP = \text{PSA reading with EUT worst orientation (dBm)} + \text{Path loss (dB)} - \text{cable loss (between the SG and substitution antenna)}$

(Path loss = Signal generator output – PSA reading with substitution antenna)

4.3. MEASUREMENT UNCERTAINTY

Where relevant, the following measurement uncertainty levels have been estimated for tests performed on the apparatus:

| PARAMETER | UNCERTAINTY |
|-----------------------------------|-------------|
| Occupied Channel Bandwidth | ±1.1 % |
| RF output power, conducted | ±0.35 dB |
| Power Spectral Density, conducted | ±0.39 dB |
| Unwanted Emissions, conducted | ±2.9 dB |
| All emissions, radiated | ±5.36 dB |
| Temperature | ±0.9 °C |
| Humidity | ±2.26% RH |
| Supply Voltages | ±0.45 % |
| Time | ±0.2 % |

Uncertainty figures are valid to a confidence level of 95%.

5. EQUIPMENT UNDER TEST

5.1. DESCRIPTION OF EUT

This EUT is a GSM/WCDMA/LTE PHONE with BT, DTS/UNII a/b/g/n/ac, GPS & NFC.

6. REUSE OF TEST DATA

6.1. EQUIPMENT UNDER TEST

According to manufacturer, FCC ID: PY7-65365K and FCC ID: PY7-88607S licensed radios (GSM850, LTE Band 12, and LTE Band 17) are electrically identical. They share the same chipset and same power. The FCC ID: PY7-65365K test data (all conducted test data) shall remain representative of FCC ID: PY7-88607S so, FCC ID: PY7-88607S leverages all conducted test data from FCC ID: PY7-65365K.

NOTE: GSM850, LTE Band 12 and LTE Band 17, Radiated Spurious Emissions was verified and presented in the test report (Section 19.1).

The applicant takes full responsibility that the test data as referenced in this section represent compliance for this FCC ID.

6.2. VERIFICATION RESULTS SUMMARY

Full verification for GSM850, LTE Band 12 and LTE Band 17 has been done on device PY7-88607S for RSE (Radiated Spurious Emissions). The data from the application has been verified through appropriate RSE testing to demonstrate compliance for this device as shown in Section 19.1.

6.3. REFERENCE DETAIL

| Equipment Class | Reference FCC ID | Report Title/Section |
|-----------------|------------------|-------------------------------|
| WWAN (PCE) | PY7-65365K | 11785223-E1V2 FCC Report WWAN |

7. MAXIMUM OUTPUT POWER

7.1. MAXIMUM OUTPUT POWER (GSM/EGPRS)

The transmitter has a maximum peak conducted and ERP / EIRP output powers as follows:

| FCC Part 22/24 | | | | | | |
|----------------|----------------------|------------|---------------------|---------|--------------------|--------|
| Band | Frequency Range(MHz) | Modulation | Conducted (Average) | | ERP/EIRP (Average) | |
| | | | AVG(dBm) | AVG(mW) | dBm | mW |
| 850 | 824~849 | GPRS | 33.4 | 2208.00 | 23.60 | 229.09 |
| | 824~849 | EGPRS | 28.6 | 716.14 | 18.80 | 75.86 |
| 1900 | 1850~1910 | GPRS | 26.6 | 460.26 | 25.13 | 325.84 |
| | 1850~1910 | EGPRS | 26.0 | 398.11 | 14.50 | 28.18 |

7.2. MAXIMUM OUTPUT POWER (WCDMA)

The transmitter has a maximum peak conducted and ERP / EIRP output powers as follows:

| FCC Part 24/27 | | | | | | |
|----------------|----------------------|------------|---------------------|---------|--------------------|-------|
| Band | Frequency Range(MHz) | Modulation | Conducted (Average) | | ERP/EIRP (Average) | |
| | | | AVG(dBm) | AVG(mW) | dBm | mW |
| Band 2 | 1850~1910 | REL99 | 18.1 | 64.57 | 16.6 | 45.71 |
| | 1850~1910 | HSDPA | 17.2 | 52.48 | 15.7 | 37.15 |
| | 1850~1910 | HSUPA | 17.3 | 53.70 | 15.8 | 38.02 |
| Band 4 | 1710~1755 | REL99 | 19.6 | 91.20 | 17.3 | 53.70 |
| | 1710~1755 | HSDPA | 18.8 | 75.86 | 16.5 | 44.67 |
| | 1710~1755 | HSUPA | 18.9 | 77.62 | 16.6 | 45.71 |

7.3. MAXIMUM OUTPUT POWER (LTE)

The transmitter has a maximum peak conducted and ERP/EIRP output powers as follows:

LTE Band 2

| FCC Part 24 | | | | | | | |
|-------------|----------------------|-----------------|------------|---------------------|---------|----------------|-------|
| Band | Frequency Range(MHz) | BandWidth (MHz) | Modulation | Conducted (Average) | | ERIP (Average) | |
| | | | | AVG(dBm) | AVG(mW) | dBm | mW |
| LTE2 | 1850~1915 | 1.4MHz | QPSK | 18.1 | 64.57 | 16.6 | 45.71 |
| | | | 16QAM | 17.9 | 61.66 | 16.4 | 43.65 |
| | | 3MHz | QPSK | 18.2 | 66.07 | 16.7 | 46.77 |
| | | | 16QAM | 18.1 | 64.57 | 16.6 | 45.71 |
| | | 5MHz | QPSK | 18.3 | 67.61 | 16.8 | 47.86 |
| | | | 16QAM | 18.2 | 66.07 | 16.7 | 46.77 |
| | | 10MHz | QPSK | 18.4 | 69.18 | 16.9 | 48.98 |
| | | | 16QAM | 18.3 | 67.61 | 16.8 | 47.86 |
| | | 15MHz | QPSK | 18.4 | 69.18 | 16.9 | 48.98 |
| | | | 16QAM | 18.3 | 67.61 | 16.8 | 47.86 |
| | | 20MHz | QPSK | 18.5 | 70.79 | 17.0 | 50.12 |
| | | | 16QAM | 18.4 | 69.18 | 16.9 | 48.98 |

LTE Band 4

| FCC Part 27 | | | | | | | |
|-------------|----------------------|-----------------|------------|---------------------|---------|----------------|---------|
| Band | Frequency Range(MHz) | BandWidth (MHz) | Modulation | Conducted (Average) | | ERIP (Average) | |
| | | | | AVG(dBm) | AVG(mW) | AVG(dBm) | AVG(mW) |
| LTE4 | 1710~1755 | 1.4MHz | QPSK | 19.90 | 97.72 | 17.60 | 57.54 |
| | | | 16QAM | 19.70 | 93.33 | 17.40 | 54.95 |
| | | 3MHz | QPSK | 20.10 | 102.33 | 17.80 | 60.26 |
| | | | 16QAM | 19.70 | 93.33 | 17.40 | 54.95 |
| | | 5MHz | QPSK | 20.00 | 100.00 | 17.70 | 58.88 |
| | | | 16QAM | 20.00 | 100.00 | 17.70 | 58.88 |
| | | 10MHz | QPSK | 20.00 | 100.00 | 17.70 | 58.88 |
| | | | 16QAM | 19.80 | 95.50 | 17.50 | 56.23 |
| | | 15MHz | QPSK | 20.00 | 100.00 | 17.70 | 58.88 |
| | | | 16QAM | 20.00 | 100.00 | 17.70 | 58.88 |
| | | 20MHz | QPSK | 20.00 | 100.00 | 17.70 | 58.88 |
| | | | 16QAM | 20.00 | 100.00 | 17.70 | 58.88 |

LTE Band 12

| FCC Part 27 | | | | | | | |
|-------------|----------------------|-----------------|------------|---------------------|---------|----------------|---------|
| Band | Frequency Range(MHz) | BandWidth (MHz) | Modulation | Conducted (Average) | | ERIP (Average) | |
| | | | | AVG(dBm) | AVG(mW) | AVG(dBm) | AVG(mW) |
| LTE12 | 699~716 | 1.4MHz | QPSK | 25.00 | 316.23 | 14.60 | 28.84 |
| | | | 16QAM | 24.00 | 251.19 | 13.60 | 22.91 |
| | | 3MHz | QPSK | 24.30 | 269.15 | 13.90 | 24.55 |
| | | | 16QAM | 24.00 | 251.19 | 13.60 | 22.91 |
| | | 5MHz | QPSK | 24.30 | 269.15 | 13.90 | 24.55 |
| | | | 16QAM | 24.00 | 251.19 | 13.60 | 22.91 |
| | | 10MHz | QPSK | 24.30 | 269.15 | 13.90 | 24.55 |
| | | | 16QAM | 23.80 | 239.88 | 13.40 | 21.88 |

LTE Band 41

| FCC Part 27 | | | | | | | |
|-------------|----------------------|-----------------|------------|---------------------|---------|----------------|----------|
| Band | Frequency Range(MHz) | BandWidth (MHz) | Modulation | Conducted (Average) | | ERIP (Average) | |
| | | | | AVG(dBm) | AVG(mW) | PEAK(dBm) | PEAK(mW) |
| LTE41 | 2496~2690 | 5MHz | QPSK | 23.90 | 245.47 | 20.10 | 102.33 |
| | | | 16QAM | 23.40 | 218.78 | 19.60 | 91.20 |
| | | 10MHz | QPSK | 23.90 | 245.47 | 20.10 | 102.33 |
| | | | 16QAM | 23.40 | 218.78 | 19.60 | 91.20 |
| | | 15MHz | QPSK | 23.90 | 245.47 | 20.10 | 102.33 |
| | | | 16QAM | 23.50 | 223.87 | 19.70 | 93.33 |
| | | 20MHz | QPSK | 23.90 | 245.47 | 20.10 | 102.33 |
| | | | 16QAM | 23.50 | 223.87 | 19.70 | 93.33 |

8. DESCRIPTION OF AVAILABLE ANTENNAS

The radio utilizes a PIFA antenna for the [List the bands supported] with a maximum peak gain as follow:

| Frequency (MHz) | Peak Gain (dBi) |
|---------------------------|-----------------|
| GSM850, 824~849MHz | -7.3 |
| GSM1900, 1850~1910MHz | -1.5 |
| WCDMA Band 2, 1850~1910 | -1.5 |
| WCDMA Band 4, 1710~1755 | -2.3 |
| LTE Band 2, 1850~1910 | -1.5 |
| LTE Band 4, 1710~1755 | -2.3 |
| LTE Band 12, 699~716MHz | -7.9 |
| LTE Band 17, 704~716MHz | -7.9 |
| LTE Band 38, 2570~2620MHz | -3.8 |
| LTE Band 41, 2496~2690MHz | -3.8 |

9. DESCRIPTION OF TEST SETUP

SUPPORT EQUIPMENT

| Support Equipment List | | | | |
|------------------------|--------------|-------------|---------------|--------|
| Description | Manufacturer | Model | Serial Number | FCC ID |
| AC Adapter | SONY | 1300-7137.1 | 4016W40310044 | NA |
| Earphone | SONY | N/A | N/A | N/A |

I/O CABLES (CONDUCTED SETUP)

| I/O Cable List | | | | | | |
|----------------|--------------|----------------------|------------------------|-------------|------------------|---------|
| Cable No | Port | # of Identical ports | Connector Type | Serial Type | Cable Length (m) | Remarks |
| 1 | RF Out | 1 | Spectrum Analyzer | Shielded | None | NA |
| 2 | Antenna Port | 1 | EUT | Shielded | 0.1m | NA |
| 3 | RF In/Out | 1 | Communication Test Set | Shielded | 1m | NA |

I/O CABLES (RADIATED SETUP)

| I/O Cable List | | | | | | |
|----------------|-----------|----------------------|------------------------|-------------|------------------|---------|
| Cable No | Port | # of Identical ports | Connector Type | Serial Type | Cable Length (m) | Remarks |
| 1 | USB | 1 | AC Adapter | Un-shielded | 1.2m | No |
| 2 | Jack | 1 | Headset | Shielded | 1m | No |
| 3 | RF In/out | 1 | Communication Test Set | Un-shielded | 2m | Yes |

TEST SETUP

The EUT is continuously communicated to the call box during the tests.

SETUP DIAGRAM FOR TESTS (CONDUCTED TEST SETUP)

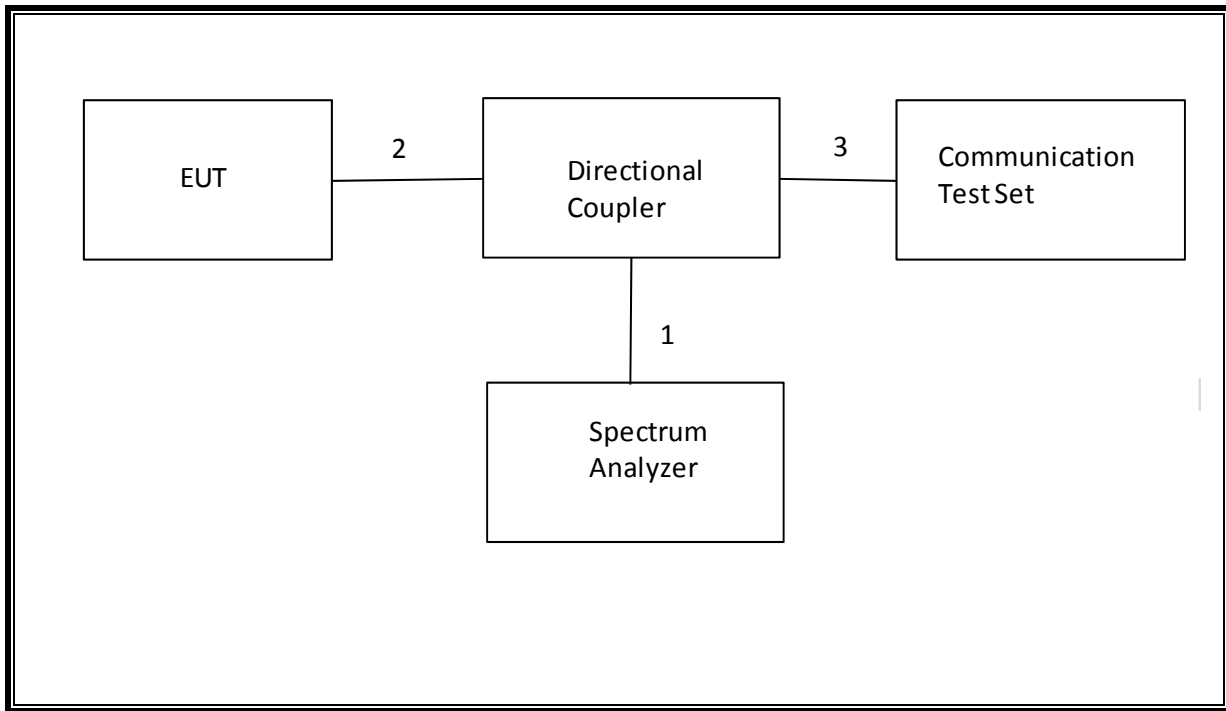

SETUP DIAGRAM FOR TESTS (RADIATED TEST SETUP)

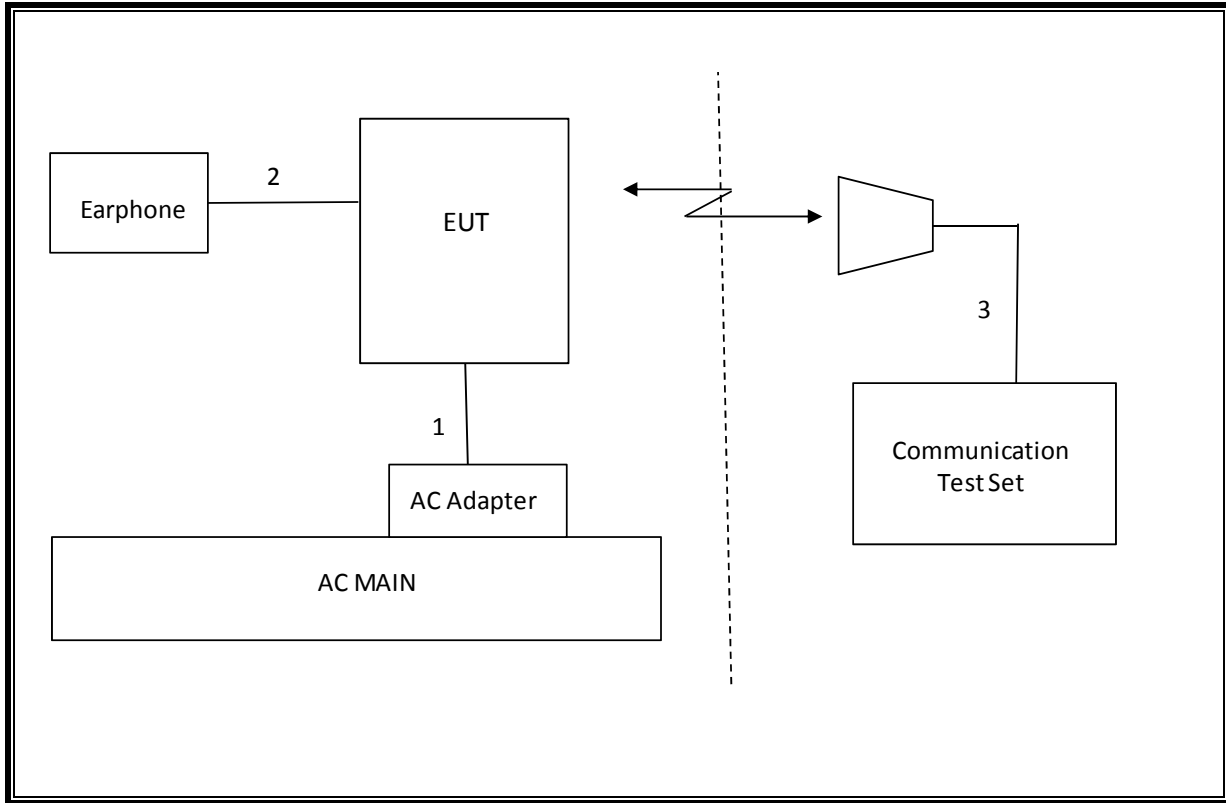

10. TEST AND MEASUREMENT EQUIPMENT

The following test and measurement equipment was utilized for the tests documented in this report:

| Test Equipment List | | | | | |
|---|----------------|------------------------|----------|----------|----------|
| Description | Manufacturer | Model | T Number | Cal Date | Cal Due |
| Amplifier, 1 to 18 GHz | Miteq | AFS43-00101800-25-S-42 | 493 | 02/15/17 | 02/15/18 |
| Amplifier, 1 to 8 GHz | Miteq | AMF-4D-01000800-30-29P | 1156 | 02/15/17 | 02/15/18 |
| Amplifier, 10KHz to 1GHz, 32dB | Keysight | 8447D | 10 | 02/15/17 | 02/15/18 |
| Antenna, Broadband Hybrid, 30MHz to 2000MHz | Sunol Sciences | JB3 | 408 | 11/10/16 | 11/10/17 |
| Spectrum Analyzer, PXA 3Hz to 44GHz | Keysight | N9030A | 907 | 01/23/17 | 01/23/18 |
| Highpass Filter, 2.7 GHz | Micro-Circuits | H2G518G6 | T772 | 07/05/16 | 07/05/18 |
| Highpass Filter, 1 GHz | Micro-Tronics | HPM18129 | T889 | 02/21/17 | 02/21/18 |
| Highpass Filter, 4GHz | Micro-Tronics | HPM13351 | T1241 | 06/17/17 | 06/17/18 |
| Amplifier, 1-18GHz | Miteq | AFS42-00101800-25-S-42 | 931 | 08/26/16 | 08/26/17 |
| Amplifier, 10KHz to 1GHz, 32dB | Keysight | 8447D | 15 | 08/26/16 | 08/26/17 |
| Antenna, Broadband Hybrid 30MHz to 2000MHz | Sunol Sciences | JB3 | 408 | 11/10/16 | 11/10/17 |
| Antenna, Horn 1-18GHz | ETS Lindgren | 3117 | 712 | 01/30/17 | 01/30/18 |
| Spectrum Analyzer, PXA, 3Hz to 44GHz | Keysight | N9030A | 905 | 01/11/17 | 01/11/18 |
| DC power supply, 8 V @ 3 A or 15 V @ 2 A | Agilent / HP | E3610A | None | CNR | None |
| Antenna, Tuned Dipole 400~1000 MHz | ETS | 3121C DB4 | T273 | 06/08/17 | 06/08/18 |
| Directional Coupler | Mini-Circuits | ZUDC10-183+ | T1136 | 06/18/17 | 06/18/18 |

| Test Equipment List | | | |
|-----------------------|--------------|--------|------------------------|
| Description | Manufacturer | Model | T Number |
| Radiated Software | UL | UL EMC | Ver 9.5, June 24, 2015 |
| Conducted Software | UL | UL EMC | Ver 9.5, May 26, 2015 |
| CLT Software | UL | UL RF | Ver 1.0, Feb 2, 2015 |
| Antenna Port Software | UL | UL RF | Ver 3.7, Nov 12, 2015 |

11. SUMMARY TABLE

| FCC Part Section | Test Description | Test Limit | Test Condition | Test Result |
|------------------------------------|---|--|----------------|-------------|
| 2.1049 | Occupied Bandwidth (99%) | N/A | Conducted | Pass |
| 22.917(a) 24.238(a) 27.53(g) | Band Edge / Conducted Spurious Emission | -13dBm | | Pass |
| 27.53(m) | | -25dBm | | Pass |
| 2.1046 | Conducted output power | N/A | | Pass |
| 27.53(m) | Emission Mask | Please refer to limit under section 14 | | Pass |
| 22.355 | Frequency Stability | 2.5PPM | | Pass |
| 24.235 27.54 | | Please refer to limit under section 16 | | Pass |
| 22.913(a)(2) | Effective Radiated Power | 38dBm | Radiated | Pass |
| 27.50©(10) | | 34.77dBm | | Pass |
| 24.232(c) 27.50(h)(2) | Equivalent Isotropic Radiated Power | 36.98dBm | | Pass |
| | | 40.6dBm | | Pass |
| 33dBm | | Pass | | |
| 27.50(d)(4) | | 30dBm | | Pass |
| 22.917(a) 24.238(a) 27.53(g) | Radiated Spurious Emission | -13dBm | | Pass |
| 27.53(m) | | -25dBm | Pass | |

12. RF POWER OUTPUT VERIFICATION

TEST PROCEDURE

ANSI C63.26:2015/ TIA / EIA 603-D Clause 2.2.17
KDB 971168 Section 5.6

$$\text{ERP/EIRP} = \text{PMeas} + \text{GT} - \text{LC}$$

where: ERP/EIRP = effective or equivalent radiated power, respectively (expressed in the same units as PMeas, typically dBW or dBm);

PMeas = measured transmitter output power or PSD, in dBm or dBW;

GT = gain of the transmitting antenna, in dBd (ERP) or dBi (EIRP);

LC = signal attenuation in the connecting cable between the transmitter and antenna, in dB.

For devices utilizing multiple antennas, KDB 662911 provides guidance for determining the effective array transmit antenna gain term to be used in the above equation.

MODES TESTED

- GSM 850
- GSM 1900
- WCDMA Band 2
- WCDMA Band 4
- LTE Band 2
- LTE Band 4
- LTE Band 12
- LTE Band 17
- LTE Band 38
- LTE Band 41

12.1. GSM/GPRS/EDGE

Using CMW500 Communication Test Set

Function: Menu select > GSM Mobile Station > GSM 850/900/1800/1900

Press Connection control to choose the different menus

Press RESET > choose all to reset all settings

| | |
|------------|--|
| Connection | Press Signal Off to turn off the signal and change settings Network Support > GSM+GPRS or GSM+EGPRS Main Service > Packet Data Service selection > Test Mode A – Auto Slot Config. off |
| MS Signal | Press Slot Config bottom on the right twice to select and change the number of time slots and power setting > Slot configuration > Uplink/Gamma > 33 dBm for GPRS 850/900 > 27 dBm for EGPRS 850/900 > 30 dBm for GPRS1800/1900 > 26 dBm for EGPRS1800/1900 |
| BS Signal | Enter the same channel number for TCH channel (test channel) and BCCH channel Frequency Offset > + 0 Hz Mode > BCCH and TCH BCCH Level > -85 dBm (May need to adjust if link is not stable) BCCH Channel > choose desire test channel [Enter the same channel number for TCH channel (test channel) and BCCH channel] Channel Type > Off P0> 4 dB Slot Config > Unchanged (if already set under MS Signal) TCH > choose desired test channel Hopping > Off Main Timeslot > 3 (Default) |
| Network | Coding Scheme > CS 4 (GPRS) and MCS5-9 (EGPRS) Bit Stream > 2E9-1PSR Bit Pattern |
| AF/RF | Enter appropriate offsets for Ext. Att. Output and Ext. Att. Input |
| Connection | Press Signal On to turn on the signal and change settings |

12.2. GSM OUTPUT POWER RESULT

| | |
|-----------|-----------------|
| Tested By | Coltyce Sanders |
| Date | 7/24/2017 |

GSM 850

| Antenna gain (dBi) | | -7.30 | | | | | | | |
|--------------------|-------|---------|-------------|-------------------------|-------------------|-----------------|-------------|-------|-------|
| Mode | Ch. | f (MHz) | Modulation | Conducted Average (dBm) | ERP Average (dBm) | ERP Limit (dBm) | Margin (dB) | | |
| GPRS | 128 | 824.2 | 1 Time slot | 33.4 | 23.6 | 38.5 | -14.9 | | |
| | 190 | 836.6 | | 33.4 | 23.6 | 38.5 | -14.9 | | |
| | 251 | 848.8 | | 33.4 | 23.6 | 38.5 | -14.9 | | |
| | GPRS | 128 | 824.2 | 2 Time slot | 33.4 | 23.6 | 38.5 | -14.9 | |
| | | 190 | 836.6 | | 33.4 | 23.6 | 38.5 | -14.9 | |
| | | 251 | 848.8 | | 33.4 | 23.6 | 38.5 | -14.9 | |
| | | GPRS | 128 | 824.2 | 3 Time slot | 31.7 | 21.9 | 38.5 | -16.6 |
| | | | 190 | 836.6 | | 31.7 | 21.9 | 38.5 | -16.6 |
| | | | 251 | 848.8 | | 31.7 | 21.9 | 38.5 | -16.7 |
| | | GPRS | 128 | 824.2 | 4 Time slot | 29.7 | 19.9 | 38.5 | -18.6 |
| | | | 190 | 836.6 | | 29.7 | 19.9 | 38.5 | -18.6 |
| | | | 251 | 848.8 | | 29.6 | 19.8 | 38.5 | -18.7 |
| EGPRS | 128 | 824.2 | 1 Time slot | 28.5 | 18.7 | 38.5 | -19.8 | | |
| | 190 | 836.6 | | 28.6 | 18.8 | 38.5 | -19.8 | | |
| | 251 | 848.8 | | 28.5 | 18.7 | 38.5 | -19.8 | | |
| | EGPRS | 128 | 824.2 | 2 Time slot | 27.3 | 17.5 | 38.5 | -21.0 | |
| | | 190 | 836.6 | | 27.3 | 17.5 | 38.5 | -21.0 | |
| | | 251 | 848.8 | | 27.2 | 17.4 | 38.5 | -21.1 | |
| | EGPRS | 128 | 824.2 | 3 Time slot | 25.0 | 15.2 | 38.5 | -23.3 | |
| | | 190 | 836.6 | | 25.2 | 15.4 | 38.5 | -23.2 | |
| | | 251 | 848.8 | | 25.1 | 15.3 | 38.5 | -23.2 | |
| | EGPRS | 128 | 824.2 | 4 Time slot | 23.2 | 13.4 | 38.5 | -25.1 | |
| | | 190 | 836.6 | | 23.1 | 13.3 | 38.5 | -25.2 | |
| | | 251 | 848.8 | | 23.0 | 13.2 | 38.5 | -25.3 | |

GSM 1900

| Antenna gain (dBi) | | -1.50 | | | | | | | |
|--------------------|-------|---------|-------------|-------------------------|--------------------|------------------|-------------|-------|-------|
| Mode | Ch. | f (MHz) | Modulation | Conducted Average (dBm) | EIRP Average (dBm) | EIRP Limit (dBm) | Margin (dB) | | |
| GPRS | 512 | 1850.2 | 1 Time slot | 26.4 | 24.9 | 33.0 | -8.1 | | |
| | 661 | 1880 | | 26.6 | 25.1 | 33.0 | -7.9 | | |
| | 810 | 1909.8 | | 26.6 | 25.1 | 33.0 | -8.0 | | |
| | GPRS | 512 | 1850.2 | 2 Time slot | 26.4 | 24.9 | 33.0 | -8.1 | |
| | | 661 | 1880 | | 26.6 | 25.1 | 33.0 | -7.9 | |
| | | 810 | 1909.8 | | 26.6 | 25.1 | 33.0 | -7.9 | |
| | | GPRS | 512 | 1850.2 | 3 Time slot | 24.0 | 22.5 | 33.0 | -10.5 |
| | | | 661 | 1880 | | 24.2 | 22.7 | 33.0 | -10.3 |
| | | | 810 | 1909.8 | | 24.6 | 23.1 | 33.0 | -9.9 |
| | | GPRS | 512 | 1850.2 | 4 Time slot | 23.0 | 21.5 | 33.0 | -11.5 |
| | | | 661 | 1880 | | 23.2 | 21.7 | 33.0 | -11.3 |
| | | | 810 | 1909.8 | | 23.3 | 21.8 | 33.0 | -11.3 |
| EGPRS | 512 | 1850.2 | 1 Time slot | 21.4 | 19.9 | 33.0 | -13.1 | | |
| | 661 | 1880 | | 21.4 | 19.9 | 33.0 | -13.1 | | |
| | 810 | 1909.8 | | 21.6 | 20.1 | 33.0 | -12.9 | | |
| | EGPRS | 512 | 1850.2 | 2 Time slot | 26.0 | 24.5 | 33.0 | -8.6 | |
| | | 661 | 1880 | | 26.0 | 24.5 | 33.0 | -8.6 | |
| | | 810 | 1909.8 | | 25.9 | 24.4 | 33.0 | -8.6 | |
| | EGPRS | 512 | 1850.2 | 3 Time slot | 23.7 | 22.2 | 33.0 | -10.8 | |
| | | 661 | 1880 | | 23.8 | 22.3 | 33.0 | -10.7 | |
| | | 810 | 1909.8 | | 23.9 | 22.4 | 33.0 | -10.6 | |
| | EGPRS | 512 | 1850.2 | 4 Time slot | 22.2 | 20.7 | 33.0 | -12.3 | |
| | | 661 | 1880 | | 22.3 | 20.8 | 33.0 | -12.2 | |
| | | 810 | 1909.8 | | 22.3 | 20.8 | 33.0 | -12.2 | |

12.3. UMTS REL 99

TEST PROCEDURE

The following summary of these settings are illustrated below:

| Mode | Subtest | Rel99 |
|------------------------|-------------------------|--------------|
| WCDMA General Settings | Loopback Mode | Test Mode 2 |
| | Rel99 RMC | 12.2kbps RMC |
| | Power Control Algorithm | Algorithm2 |
| | β_c/β_d | 8/15 |

RESULTS

| | |
|-----------|-------------|
| Tested By | AJ Newcomer |
| Date | 7/6/2017 |

12.4. UMTS REL 99 OUTPUT POWER RESULT

| | |
|---------------------------|-------|
| Antenna gain Band 2 (dBi) | -1.50 |
| Antenna gain Band 4 (dBi) | -2.30 |

Part 24 / RSS 133 1900MHz Band

| Band | UL Channel | DL Channel | Frequency (MHz) | Peak Power (dBm) | ERIP Average (dBm) | ERIP Limit (dBm) | Margin (dB) |
|-------------------------|------------|------------|-----------------|------------------|--------------------|------------------|-------------|
| UMTS Rel. 99 1900MHz | 9262 | 9662 | 1852.4 | 18.1 | 16.6 | 33.0 | -16.4 |
| | 9400 | 9800 | 1880.0 | 18.0 | 16.5 | 33.0 | -16.5 |
| | 9538 | 9938 | 1907.6 | 18.0 | 16.5 | 33.0 | -16.5 |

Part 27 / RSS 139 1700MHz Band

| Band | UL Channel | DL Channel | Frequency (MHz) | Peak Power (dBm) | ERIP Average (dBm) | ERIP Limit (dBm) | Margin (dB) |
|-------------------------|------------|------------|-----------------|------------------|--------------------|------------------|-------------|
| UMTS Rel. 99 1700MHz | 1312 | 1537 | 1712.4 | 19.5 | 17.2 | 30.0 | -12.8 |
| | 1413 | 1638 | 1732.6 | 19.5 | 17.2 | 30.0 | -12.8 |
| | 1513 | 1738 | 1752.6 | 19.6 | 17.3 | 30.0 | -12.7 |

12.5. UMTS HSDPA

The following 4 Sub-tests were completed according to Release 5 procedures in section 5.2 of 3GPP TS34.121.

Summary of settings are illustrated below:

| Mode | HSDPA | HSDPA | HSDPA | HSDPA | |
|--------------------------------------|----------------------------|-------|-------|-------|-------|
| Subtest | 1 | 2 | 3 | 4 | |
| W-CDMA General Settings | Loopback Mode | | | | |
| | Test Mode 1 | | | | |
| | Rel99 RMC | | | | |
| | 12.2kbps RMC | | | | |
| | HSDPA FRC | | | | |
| | H-Set 1 | | | | |
| | Power Control Algorithm | | | | |
| | Algorithm 2 | | | | |
| | β_c | 2/15 | 11/15 | 15/15 | 15/15 |
| | β_d | 15/15 | 15/15 | 8/15 | 4/15 |
| Bd (SF) | 64 | | | | |
| β_c/β_d | 2/15 | 11/15 | 15/8 | 15/4 | |
| β_{hs} | 4/15 | 24/15 | 30/15 | 30/15 | |
| MPR (dB) | 0 | 0 | 0.5 | 0.5 | |
| HSDPA Specific Settings | D_{ACK} | | | | |
| | 8 | | | | |
| | D_{NAK} | | | | |
| | 8 | | | | |
| | DCQI | | | | |
| | 8 | | | | |
| | Ack-Nack repetition factor | | | | |
| 3 | | | | | |
| CQI Feedback (Table 5.2B.4) | | | | | |
| 4ms | | | | | |
| CQI Repetition Factor (Table 5.2B.4) | | | | | |
| 2 | | | | | |
| $A_{hs}=\beta_{hs}/\beta_c$ | | | | | |
| 30/15 | | | | | |

RESULTS

| | |
|-----------|------------------|
| Tested By | Vanessa Moestopo |
| Date | 7/8/2017 |

12.6. UMTS HSDPA OUTPUT POWER RESULT

| | |
|---------------------------|-------|
| Antenna gain Band 2 (dBi) | -1.50 |
| Antenna gain Band 4 (dBi) | -2.30 |

Part 24 / RSS 133 1900MHz Band

| Band | Subtest | UL Channel | DL Channel | Frequency (MHz) | Conducted Average (dBm) | ERP Average (dBm) | ERP Limit (dBm) | Margin (dB) |
|--------------------|---------|------------|------------|-----------------|-------------------------|-------------------|-----------------|-------------|
| UMTS HSDPA 1900MHz | 1 | 9262 | 9662 | 1852.4 | 17.2 | 15.7 | 33.0 | -15.8 |
| | | 9400 | 9800 | 1880.0 | 17.2 | 15.7 | 33.0 | -15.8 |
| | | 9538 | 9938 | 1907.6 | 17.0 | 15.5 | 33.0 | -16.0 |
| | 2 | 9262 | 9662 | 1852.4 | 17.2 | 15.7 | 33.0 | -15.8 |
| | | 9400 | 9800 | 1880.0 | 17.1 | 15.6 | 33.0 | -15.9 |
| | | 9538 | 9938 | 1907.6 | 17.1 | 15.6 | 33.0 | -15.9 |
| | 3 | 9262 | 9662 | 1852.4 | 16.9 | 15.4 | 33.0 | -16.1 |
| | | 9400 | 9800 | 1880.0 | 16.5 | 15.0 | 33.0 | -16.5 |
| | | 9538 | 9938 | 1907.6 | 16.6 | 15.1 | 33.0 | -16.4 |
| | 4 | 9262 | 9662 | 1852.4 | 16.9 | 15.4 | 33.0 | -16.1 |
| | | 9400 | 9800 | 1880.0 | 16.5 | 15.0 | 33.0 | -16.5 |
| | | 9538 | 9938 | 1907.6 | 16.6 | 15.1 | 33.0 | -16.4 |

Part 27 / RSS 139 1700MHz Band

| Band | Subtest | UL Channel | DL Channel | Frequency (MHz) | Conducted Average (dBm) | ERP Average (dBm) | ERP Limit (dBm) | Margin (dB) |
|--------------------|---------|------------|------------|-----------------|-------------------------|-------------------|-----------------|-------------|
| UMTS HSDPA 1700MHz | 1 | 1312 | 1537 | 1712.4 | 18.5 | 16.2 | 30.0 | -11.5 |
| | | 1413 | 1638 | 1732.6 | 18.7 | 16.4 | 30.0 | -11.3 |
| | | 1513 | 1738 | 1752.6 | 18.8 | 16.5 | 30.0 | -11.2 |
| | 2 | 1312 | 1537 | 1712.4 | 18.3 | 16.0 | 30.0 | -11.7 |
| | | 1413 | 1638 | 1732.6 | 18.5 | 16.2 | 30.0 | -11.5 |
| | | 1513 | 1738 | 1752.6 | 18.4 | 16.1 | 30.0 | -11.6 |
| | 3 | 1312 | 1537 | 1712.4 | 17.8 | 15.5 | 30.0 | -12.2 |
| | | 1413 | 1638 | 1732.6 | 18.1 | 15.8 | 30.0 | -11.9 |
| | | 1513 | 1738 | 1752.6 | 18.1 | 15.8 | 30.0 | -11.9 |
| | 4 | 1312 | 1537 | 1712.4 | 17.8 | 15.5 | 30.0 | -12.2 |
| | | 1413 | 1638 | 1732.6 | 18.1 | 15.8 | 30.0 | -11.9 |
| | | 1513 | 1738 | 1752.6 | 18.1 | 15.8 | 30.0 | -11.9 |

12.7. UMTS HSUPA

The following 5 Sub-tests were completed according to Release 6 procedures in section 5.2 of 3GPP TS34.121.

Summary of settings are illustrated below:

| | Mode | HSPA | | | | |
|--|--------------------------------------|---------------|-------|-------|-------|-------------|
| | Subtest | 1 | 2 | 3 | 4 | 5 |
| WCDMA General Settings | Loopback Mode | Test Mode 1 | | | | |
| | Rel99 RMC | 12.2 kbps RMC | | | | |
| | HSDPA FRC | H-Set 1 | | | | |
| | HSUPA Test | HSPA | | | | |
| | Power Control Algorithm | Algorithm 2 | | | | Algorithm 1 |
| | β_c | 11/15 | 6/15 | 15/15 | 2/15 | 15/15 |
| | β_d | 15/15 | 15/15 | 9/15 | 15/15 | 0 |
| | β_{ec} | 209/225 | 12/15 | 30/15 | 2/15 | 5/15 |
| | β_c/β_d | 11/15 | 6/15 | 15/9 | 2/15 | - |
| | β_{hs} | 22/15 | 12/15 | 30/15 | 4/15 | 5/15 |
| | β_{ed} | 1309/225 | 94/75 | 47/15 | 56/75 | 47/15 |
| | CM (dB) | 1 | 3 | 2 | 3 | 1 |
| | MPR (dB) | 0 | 2 | 1 | 2 | 0 |
| HSDPA Specific Settings | DACK | 8 | | | | 0 |
| | DNAK | 8 | | | | 0 |
| | DCQI | 8 | | | | 0 |
| | Ack-Nack repetition factor | 3 | | | | |
| | CQI Feedback (Table 5.2B.4) | 4ms | | | | |
| | CQI Repetition Factor (Table 5.2B.4) | 2 | | | | |
| A _{hs} = β_{hs}/β_c | 30/15 | | | | | |
| HSUPA Specific Settings | E-DPDCCH | 6 | 8 | 8 | 5 | 0 |
| | DHARQ | 0 | 0 | 0 | 0 | 0 |
| | AG Index | 20 | 12 | 15 | 17 | 12 |
| | ETFCI (from 34.121 Table C.11.1.3) | 75 | 67 | 92 | 71 | 67 |
| | Associated Max UL Data Rate kbps | 242.1 | 174.9 | 482.8 | 205.8 | 308.9 |
| | Reference E-TFCIs | 5 | 5 | 2 | 5 | 1 |
| | Reference E-TFCI | 11 | 11 | 11 | 11 | 67 |
| | Reference E-TFCI PO | 4 | 4 | 4 | 4 | 18 |
| | Reference E-TFCI | 67 | 67 | 92 | 67 | 67 |
| | Reference E-TFCI PO | 18 | 18 | 18 | 18 | 18 |
| | Reference E-TFCI | 71 | 71 | 71 | 71 | 71 |
| | Reference E-TFCI PO | 23 | 23 | 23 | 23 | 23 |
| | Reference E-TFCI | 75 | 75 | 75 | 75 | 75 |
| | Reference E-TFCI PO | 26 | 26 | 26 | 26 | 26 |
| | Reference E-TFCI | 81 | 81 | 81 | 81 | 81 |
| | Reference E-TFCI PO | 27 | 27 | 27 | 27 | 27 |
| Maximum Channelization Codes | 2xSF2 | | | | SF4 | |

Note1: β_{ed} cannot be set directly, it is set by Absolute Grant Value.

RESULT

| | |
|-----------|------------------|
| Tested By | Vanessa Moestopo |
| Date | 7/8/2017 |

12.8. UMTS HSUPA OUTPUT POWER RESULT

| | |
|---------------------------|-------|
| Antenna gain Band 2 (dBi) | -1.50 |
| Antenna gain Band 4 (dBi) | -2.30 |

Part 24 / RSS 133 1900MHz Band

| Band | Subtest | UL Channel | DL Channel | Frequency (MHz) | Conducted Average (dBm) | ERP Average (dBm) | ERP Limit (dBm) | Margin (dB) |
|--------------------|---------|------------|------------|-----------------|-------------------------|-------------------|-----------------|-------------|
| UMTS HSUPA 1900MHz | 1 | 9262 | 9662 | 1852.4 | 17.3 | 15.8 | 33.0 | -15.7 |
| | | 9400 | 9800 | 1880.0 | 17.3 | 15.8 | 33.0 | -15.7 |
| | | 9538 | 9938 | 1907.6 | 17.2 | 15.7 | 33.0 | -15.8 |
| | 2 | 9262 | 9662 | 1852.4 | 15.3 | 13.8 | 33.0 | -17.7 |
| | | 9400 | 9800 | 1880.0 | 15.3 | 13.8 | 33.0 | -17.7 |
| | | 9538 | 9938 | 1907.6 | 15.1 | 13.6 | 33.0 | -17.9 |
| | 3 | 9262 | 9662 | 1852.4 | 16.4 | 14.9 | 33.0 | -16.6 |
| | | 9400 | 9800 | 1880.0 | 16.2 | 14.7 | 33.0 | -16.8 |
| | | 9538 | 9938 | 1907.6 | 16.2 | 14.7 | 33.0 | -16.8 |
| | 4 | 9262 | 9662 | 1852.4 | 15.3 | 13.8 | 33.0 | -17.7 |
| | | 9400 | 9800 | 1880.0 | 15.3 | 13.8 | 33.0 | -17.7 |
| | | 9538 | 9938 | 1907.6 | 15.1 | 13.6 | 33.0 | -17.9 |
| | 5 | 9262 | 9662 | 1852.4 | 17.3 | 15.8 | 33.0 | -15.7 |
| | | 9400 | 9800 | 1880.0 | 17.2 | 15.7 | 33.0 | -15.8 |
| | | 9538 | 9938 | 1907.6 | 17.0 | 15.5 | 33.0 | -16.0 |

Part 27 / RSS 139 1700MHz Band

| Band | Subtest | UL Channel | DL Channel | Frequency (MHz) | Conducted Average (dBm) | ERP Average (dBm) | ERP Limit (dBm) | Margin (dB) |
|--------------------|---------|------------|------------|-----------------|-------------------------|-------------------|-----------------|-------------|
| UMTS HSUPA 1700MHz | 1 | 1312 | 1537 | 1712.4 | 18.3 | 16.0 | 30.0 | -11.7 |
| | | 1413 | 1638 | 1732.6 | 18.6 | 16.3 | 30.0 | -11.4 |
| | | 1513 | 1738 | 1752.6 | 18.9 | 16.6 | 30.0 | -11.1 |
| | 2 | 1312 | 1537 | 1712.4 | 16.5 | 14.2 | 30.0 | -13.5 |
| | | 1413 | 1638 | 1732.6 | 16.8 | 14.5 | 30.0 | -13.2 |
| | | 1513 | 1738 | 1752.6 | 16.9 | 14.6 | 30.0 | -13.1 |
| | 3 | 1312 | 1537 | 1712.4 | 17.5 | 15.2 | 30.0 | -12.5 |
| | | 1413 | 1638 | 1732.6 | 17.7 | 15.4 | 30.0 | -12.3 |
| | | 1513 | 1738 | 1752.6 | 17.8 | 15.5 | 30.0 | -12.2 |
| | 4 | 1312 | 1537 | 1712.4 | 16.5 | 14.2 | 30.0 | -13.5 |
| | | 1413 | 1638 | 1732.6 | 16.8 | 14.5 | 30.0 | -13.2 |
| | | 1513 | 1738 | 1752.6 | 16.9 | 14.6 | 30.0 | -13.1 |
| | 5 | 1312 | 1537 | 1712.4 | 18.3 | 16.0 | 30.0 | -11.7 |
| | | 1413 | 1638 | 1732.6 | 18.6 | 16.3 | 30.0 | -11.4 |
| | | 1513 | 1738 | 1752.6 | 18.9 | 16.6 | 30.0 | -11.1 |

12.9. LTE OUTPUT POWER RESULT

Note(s):

LTE Band 17 Measured Results

LTE Band 17 (Frequency range: 704-716) is covered by LTE Band 12 (Frequency range: 699-716MHz) no testing is necessary due to overlapping frequency range, same maximum tune-up limit and same channel bandwidth and same modulations.

LTE Band 38 Measured Results

LTE Band 38 (Frequency range: 2570-2620 MHz) is covered by LTE Band 41 (Frequency range: 2496-2690 MHz) and no testing is necessary due to overlapping frequency range, same maximum tune-up limit and same channel bandwidth and same modulations.

64QAM Measured Results

Measured QPSK,16QAM & 64QAM Mode Output power and found that QPSK and 16QAM results was the worst case. All testing were performed using QPSK and 16QAM mode to represent the worst case mode.

| | |
|-----------|-------------------------------|
| Tested By | Vanessa Moestopo/Nathan Sousa |
| Date | 7/6-8/2017 |

LTE Band 2

| Antenna gain (dBi) | | -1.50 | | | | | | | | | | |
|--------------------|------------|-----------------|------------|---------|-----------|-------------------------|--------------------|------------------|-------------|------|------|-------|
| Bandwidth | UL Channel | Frequency (MHz) | Modulation | RB Size | RB Offset | Conducted Average (dBm) | EIRP Average (dBm) | EIRP Limit (dBm) | Margin (dB) | | | |
| 1.4 | 18607 | 1850.7 | QPSK | 1 | 0 | 18.1 | 16.6 | 33.0 | -16.5 | | | |
| | | | | 1 | 3 | 18.1 | 16.6 | 33.0 | -16.4 | | | |
| | | | | 1 | 5 | 18.1 | 16.6 | 33.0 | -16.4 | | | |
| | | | | 3 | 0 | 18.1 | 16.6 | 33.0 | -16.4 | | | |
| | | | | 3 | 1 | 18.1 | 16.6 | 33.0 | -16.4 | | | |
| | | | | 3 | 3 | 18.1 | 16.6 | 33.0 | -16.4 | | | |
| | | | 16QAM | 1 | 0 | 17.6 | 16.1 | 33.0 | -16.9 | | | |
| | | | | 1 | 3 | 17.7 | 16.2 | 33.0 | -16.8 | | | |
| | | | | 1 | 5 | 17.6 | 16.1 | 33.0 | -16.9 | | | |
| | | | | 3 | 0 | 17.8 | 16.3 | 33.0 | -16.7 | | | |
| | | | | 3 | 1 | 17.9 | 16.4 | 33.0 | -16.6 | | | |
| | | | | 3 | 3 | 17.9 | 16.4 | 33.0 | -16.6 | | | |
| | | | 64QAM | 1 | 0 | 17.2 | 15.7 | 33.0 | -17.3 | | | |
| | | | | 1 | 3 | 17.5 | 16.0 | 33.0 | -17.0 | | | |
| | | | | 1 | 5 | 17.5 | 16.0 | 33.0 | -17.0 | | | |
| | | | | 3 | 0 | 17.3 | 15.8 | 33.0 | -17.2 | | | |
| | | | | 3 | 1 | 17.2 | 15.7 | 33.0 | -17.3 | | | |
| | | | | 3 | 3 | 17.2 | 15.7 | 33.0 | -17.3 | | | |
| | | | 1.4 | 18900 | 1880.0 | QPSK | 1 | 0 | 18.0 | 16.5 | 33.0 | -16.5 |
| | | | | | | | 1 | 3 | 18.1 | 16.6 | 33.0 | -16.4 |
| | | | | | | | 1 | 5 | 18.0 | 16.5 | 33.0 | -16.5 |
| | | | | | | | 3 | 0 | 18.0 | 16.5 | 33.0 | -16.5 |
| | | | | | | | 3 | 1 | 18.1 | 16.6 | 33.0 | -16.4 |
| | | | | | | | 3 | 3 | 18.1 | 16.6 | 33.0 | -16.4 |
| 16QAM | 6 | 0 | | | | 18.0 | 16.5 | 33.0 | -16.5 | | | |
| | 1 | 0 | | | | 17.9 | 16.4 | 33.0 | -16.6 | | | |
| | 1 | 3 | | | | 17.9 | 16.4 | 33.0 | -16.6 | | | |
| | 1 | 5 | | | | 17.9 | 16.4 | 33.0 | -16.6 | | | |
| | 3 | 0 | | | | 17.8 | 16.3 | 33.0 | -16.8 | | | |
| | 3 | 1 | | | | 17.8 | 16.3 | 33.0 | -16.7 | | | |
| 64QAM | 3 | 3 | | | | 17.8 | 16.3 | 33.0 | -16.7 | | | |
| | 6 | 0 | | | | 17.5 | 16.0 | 33.0 | -17.0 | | | |
| | 1 | 0 | | | | 17.2 | 15.7 | 33.0 | -17.3 | | | |
| | 1 | 3 | | | | 17.2 | 15.7 | 33.0 | -17.3 | | | |
| | 1 | 5 | | | | 17.1 | 15.6 | 33.0 | -17.4 | | | |
| | 3 | 0 | | | | 17.1 | 15.6 | 33.0 | -17.4 | | | |
| | 3 | 1 | | | | 17.1 | 15.6 | 33.0 | -17.4 | | | |
| | 3 | 3 | | | | 17.1 | 15.6 | 33.0 | -17.4 | | | |
| | 6 | 0 | | | | 17.1 | 15.6 | 33.0 | -17.4 | | | |

| Antenna gain (dBi) | | -1.50 | | | | | | | | | |
|--------------------|------------|-----------------|------------|---------|-----------|-------------------------|--------------------|------------------|-------------|------|-------|
| Bandwidth | UL Channel | Frequency (MHz) | Modulation | RB Size | RB Offset | Conducted Average (dBm) | EIRP Average (dBm) | EIRP Limit (dBm) | Margin (dB) | | |
| 1.4 | 19193 | 1919.3 | QPSK | 1 | 0 | 18.0 | 16.5 | 33.0 | -16.5 | | |
| | | | | 1 | 8 | 18.1 | 16.6 | 33.0 | -16.4 | | |
| | | | | 1 | 14 | 18.0 | 16.5 | 33.0 | -16.5 | | |
| | | | | 3 | 0 | 18.0 | 16.5 | 33.0 | -16.5 | | |
| | | | | 3 | 4 | 18.1 | 16.6 | 33.0 | -16.5 | | |
| | | | | 3 | 7 | 18.1 | 16.6 | 33.0 | -16.4 | | |
| | | | 16QAM | 6 | 0 | 18.0 | 16.5 | 33.0 | -16.5 | | |
| | | | | 1 | 0 | 17.6 | 16.1 | 33.0 | -16.9 | | |
| | | | | 1 | 8 | 17.7 | 16.2 | 33.0 | -16.9 | | |
| | | | | 1 | 14 | 17.6 | 16.1 | 33.0 | -16.9 | | |
| | | | | 3 | 0 | 17.6 | 16.1 | 33.0 | -16.9 | | |
| | | | | 3 | 4 | 17.7 | 16.2 | 33.0 | -16.8 | | |
| | | | 64QAM | 3 | 7 | 17.7 | 16.2 | 33.0 | -16.8 | | |
| | | | | 6 | 0 | 17.7 | 16.2 | 33.0 | -16.8 | | |
| | | | | 1 | 0 | 17.3 | 15.8 | 33.0 | -17.2 | | |
| | | | | 1 | 8 | 17.4 | 15.9 | 33.0 | -17.1 | | |
| | | | | 1 | 14 | 17.4 | 15.9 | 33.0 | -17.1 | | |
| | | | | 3 | 0 | 17.1 | 15.6 | 33.0 | -17.4 | | |
| | | | | | | 3 | 4 | 17.2 | 15.7 | 33.0 | -17.3 |
| | | | | | | 3 | 7 | 17.2 | 15.7 | 33.0 | -17.3 |
| | | | | | | 6 | 0 | 17.2 | 15.7 | 33.0 | -17.3 |

| Antenna gain (dBi) | | -1.50 | | | | | | | | | | |
|--------------------|------------|-----------------|------------|---------|-----------|-------------------------|--------------------|------------------|-------------|------|------|-------|
| Bandwidth | UL Channel | Frequency (MHz) | Modulation | RB Size | RB Offset | Conducted Average (dBm) | EIRP Average (dBm) | EIRP Limit (dBm) | Margin (dB) | | | |
| 3.0 | 18615 | 1851.5 | QPSK | 1 | 0 | 18.2 | 16.7 | 33.0 | -16.4 | | | |
| | | | | 1 | 8 | 18.2 | 16.7 | 33.0 | -16.3 | | | |
| | | | | 1 | 14 | 18.1 | 16.6 | 33.0 | -16.4 | | | |
| | | | | 8 | 0 | 18.2 | 16.7 | 33.0 | -16.3 | | | |
| | | | | 8 | 4 | 18.2 | 16.7 | 33.0 | -16.3 | | | |
| | | | | 8 | 7 | 18.2 | 16.7 | 33.0 | -16.3 | | | |
| | | | 16QAM | 15 | 0 | 18.2 | 16.7 | 33.0 | -16.3 | | | |
| | | | | 1 | 0 | 17.8 | 16.3 | 33.0 | -16.7 | | | |
| | | | | 1 | 8 | 17.8 | 16.3 | 33.0 | -16.7 | | | |
| | | | | 1 | 14 | 17.7 | 16.2 | 33.0 | -16.8 | | | |
| | | | | 8 | 0 | 17.8 | 16.3 | 33.0 | -16.7 | | | |
| | | | | 8 | 4 | 17.8 | 16.3 | 33.0 | -16.7 | | | |
| | | | 64QAM | 8 | 7 | 17.8 | 16.3 | 33.0 | -16.7 | | | |
| | | | | 15 | 0 | 17.7 | 16.2 | 33.0 | -16.8 | | | |
| | | | | 1 | 0 | 17.2 | 15.7 | 33.0 | -17.3 | | | |
| | | | | 1 | 8 | 17.5 | 16.0 | 33.0 | -17.0 | | | |
| | | | | 1 | 14 | 17.5 | 16.0 | 33.0 | -17.0 | | | |
| | | | | 8 | 0 | 17.2 | 15.7 | 33.0 | -17.3 | | | |
| | | | 3.0 | 18900 | 1880.0 | QPSK | 8 | 4 | 17.2 | 15.7 | 33.0 | -17.3 |
| | | | | | | | 8 | 7 | 17.2 | 15.7 | 33.0 | -17.3 |
| | | | | | | | 15 | 0 | 17.2 | 15.7 | 33.0 | -17.3 |
| 1 | 0 | 18.2 | | | | | 16.7 | 33.0 | -16.3 | | | |
| 1 | 8 | 18.2 | | | | | 16.7 | 33.0 | -16.3 | | | |
| 1 | 14 | 18.1 | | | | | 16.6 | 33.0 | -16.4 | | | |
| 16QAM | 8 | 0 | | | | 18.1 | 16.6 | 33.0 | -16.4 | | | |
| | 8 | 4 | | | | 18.1 | 16.6 | 33.0 | -16.4 | | | |
| | 8 | 7 | | | | 18.1 | 16.6 | 33.0 | -16.4 | | | |
| | 15 | 0 | | | | 18.1 | 16.6 | 33.0 | -16.4 | | | |
| | 1 | 0 | | | | 18.0 | 16.5 | 33.0 | -16.5 | | | |
| | 1 | 8 | | | | 18.1 | 16.6 | 33.0 | -16.4 | | | |
| 64QAM | 1 | 14 | | | | 18.0 | 16.5 | 33.0 | -16.5 | | | |
| | 8 | 0 | | | | 17.7 | 16.2 | 33.0 | -16.8 | | | |
| | 8 | 4 | | | | 17.7 | 16.2 | 33.0 | -16.8 | | | |
| | 8 | 7 | | | | 17.7 | 16.2 | 33.0 | -16.8 | | | |
| | 15 | 0 | | | | 17.7 | 16.2 | 33.0 | -16.8 | | | |
| | 1 | 0 | | | | 17.4 | 15.9 | 33.0 | -17.1 | | | |
| | 1 | 8 | | | | 17.3 | 15.8 | 33.0 | -17.2 | | | |
| | 1 | 14 | | | | 17.3 | 15.8 | 33.0 | -17.2 | | | |
| | 8 | 0 | | | | 17.0 | 15.5 | 33.0 | -17.5 | | | |
| 8 | 4 | 17.1 | 15.6 | 33.0 | -17.4 | | | | | | | |
| 8 | 7 | 17.0 | 15.5 | 33.0 | -17.5 | | | | | | | |
| 15 | 0 | 17.1 | 15.6 | 33.0 | -17.4 | | | | | | | |

| Antenna gain (dBi) | | -1.50 | | | | | | | |
|--------------------|------------|-----------------|------------|---------|-----------|-------------------------|--------------------|------------------|-------------|
| Bandwidth | UL Channel | Frequency (MHz) | Modulation | RB Size | RB Offset | Conducted Average (dBm) | EIRP Average (dBm) | EIRP Limit (dBm) | Margin (dB) |
| 3.0 | 19185 | 1908.5 | QPSK | 1 | 0 | 18.1 | 16.6 | 33.0 | -16.4 |
| | | | | 1 | 8 | 18.2 | 16.7 | 33.0 | -16.3 |
| | | | | 1 | 14 | 18.1 | 16.6 | 33.0 | -16.4 |
| | | | | 8 | 0 | 18.2 | 16.7 | 33.0 | -16.4 |
| | | | | 8 | 4 | 18.2 | 16.7 | 33.0 | -16.3 |
| | | | | 8 | 7 | 18.2 | 16.7 | 33.0 | -16.3 |
| | | | | 15 | 0 | 18.2 | 16.7 | 33.0 | -16.4 |
| | | | 16QAM | 1 | 0 | 17.6 | 16.1 | 33.0 | -17.0 |
| | | | | 1 | 8 | 17.6 | 16.1 | 33.0 | -16.9 |
| | | | | 1 | 14 | 17.5 | 16.0 | 33.0 | -17.0 |
| | | | | 8 | 0 | 17.8 | 16.3 | 33.0 | -16.7 |
| | | | | 8 | 4 | 17.8 | 16.3 | 33.0 | -16.7 |
| | | | | 8 | 7 | 17.8 | 16.3 | 33.0 | -16.7 |
| | | | | 15 | 0 | 17.7 | 16.2 | 33.0 | -16.8 |
| | | | 64QAM | 1 | 0 | 17.4 | 15.9 | 33.0 | -17.1 |
| | | | | 1 | 8 | 17.4 | 15.9 | 33.0 | -17.1 |
| | | | | 1 | 14 | 17.4 | 15.9 | 33.0 | -17.1 |
| | | | | 8 | 0 | 17.1 | 15.6 | 33.0 | -17.4 |
| | | | | 8 | 4 | 17.2 | 15.7 | 33.0 | -17.3 |
| | | | | 8 | 7 | 17.1 | 15.6 | 33.0 | -17.4 |
| | | | | 15 | 0 | 17.1 | 15.6 | 33.0 | -17.4 |

| Antenna gain (dBi) | | -1.50 | | | | | | | | | | |
|--------------------|------------|-----------------|------------|---------|-----------|-------------------------|--------------------|------------------|-------------|------|------|-------|
| Bandwidth | UL Channel | Frequency (MHz) | Modulation | RB Size | RB Offset | Conducted Average (dBm) | EIRP Average (dBm) | EIRP Limit (dBm) | Margin (dB) | | | |
| 5.0 | 625 | 1852.5 | QPSK | 1 | 0 | 18.3 | 16.8 | 33.0 | -16.2 | | | |
| | | | | 1 | 12 | 18.2 | 16.7 | 33.0 | -16.3 | | | |
| | | | | 1 | 24 | 18.1 | 16.6 | 33.0 | -16.4 | | | |
| | | | | 12 | 0 | 18.2 | 16.7 | 33.0 | -16.3 | | | |
| | | | | 12 | 7 | 18.2 | 16.7 | 33.0 | -16.3 | | | |
| | | | | 12 | 13 | 18.2 | 16.7 | 33.0 | -16.3 | | | |
| | | | 16QAM | 25 | 0 | 18.2 | 16.7 | 33.0 | -16.3 | | | |
| | | | | 1 | 0 | 17.9 | 16.4 | 33.0 | -16.6 | | | |
| | | | | 1 | 12 | 17.8 | 16.3 | 33.0 | -16.7 | | | |
| | | | | 1 | 24 | 17.8 | 16.3 | 33.0 | -16.8 | | | |
| | | | | 12 | 0 | 17.9 | 16.4 | 33.0 | -16.6 | | | |
| | | | | 12 | 7 | 17.8 | 16.3 | 33.0 | -16.7 | | | |
| | | | 64QAM | 12 | 13 | 17.8 | 16.3 | 33.0 | -16.7 | | | |
| | | | | 25 | 0 | 17.7 | 16.2 | 33.0 | -16.8 | | | |
| | | | | 1 | 0 | 17.7 | 16.2 | 33.0 | -16.8 | | | |
| | | | | 1 | 12 | 17.5 | 16.0 | 33.0 | -17.0 | | | |
| | | | | 1 | 24 | 17.5 | 16.0 | 33.0 | -17.0 | | | |
| | | | | 12 | 0 | 17.3 | 15.8 | 33.0 | -17.2 | | | |
| | | | 5.0 | 18900 | 1880.0 | QPSK | 12 | 7 | 17.2 | 15.7 | 33.0 | -17.3 |
| | | | | | | | 12 | 13 | 17.2 | 15.7 | 33.0 | -17.3 |
| | | | | | | | 25 | 0 | 17.2 | 15.7 | 33.0 | -17.3 |
| 1 | 0 | 18.2 | | | | | 16.7 | 33.0 | -16.3 | | | |
| 1 | 12 | 18.1 | | | | | 16.6 | 33.0 | -16.4 | | | |
| 1 | 24 | 18.1 | | | | | 16.6 | 33.0 | -16.4 | | | |
| 16QAM | 12 | 0 | | | | 18.1 | 16.6 | 33.0 | -16.4 | | | |
| | 12 | 7 | | | | 18.1 | 16.6 | 33.0 | -16.4 | | | |
| | 12 | 13 | | | | 18.1 | 16.6 | 33.0 | -16.4 | | | |
| | 25 | 0 | | | | 18.1 | 16.6 | 33.0 | -16.4 | | | |
| | 1 | 0 | | | | 18.2 | 16.7 | 33.0 | -16.3 | | | |
| | 1 | 2 | | | | 18.2 | 16.7 | 33.0 | -16.4 | | | |
| 64QAM | 1 | 5 | | | | 18.2 | 16.7 | 33.0 | -16.3 | | | |
| | 3 | 0 | | | | 17.9 | 16.4 | 33.0 | -16.6 | | | |
| | 3 | 1 | | | | 17.8 | 16.3 | 33.0 | -16.7 | | | |
| | 3 | 2 | | | | 17.8 | 16.3 | 33.0 | -16.7 | | | |
| | 6 | 0 | | | | 17.7 | 16.2 | 33.0 | -16.8 | | | |
| | 1 | 0 | | | | 17.5 | 16.0 | 33.0 | -17.0 | | | |
| 16QAM | 1 | 12 | | | | 17.5 | 16.0 | 33.0 | -17.0 | | | |
| | 1 | 24 | | | | 17.5 | 16.0 | 33.0 | -17.0 | | | |
| | 12 | 0 | | | | 17.2 | 15.7 | 33.0 | -17.3 | | | |
| | 12 | 7 | 17.1 | 15.6 | 33.0 | -17.4 | | | | | | |
| | 12 | 13 | 17.1 | 15.6 | 33.0 | -17.4 | | | | | | |
| | 25 | 0 | 17.1 | 15.6 | 33.0 | -17.4 | | | | | | |

| Antenna gain (dBi) | | -1.50 | | | | | | | |
|--------------------|------------|-----------------|------------|---------|-----------|-------------------------|--------------------|------------------|-------------|
| Bandwidth | UL Channel | Frequency (MHz) | Modulation | RB Size | RB Offset | Conducted Average (dBm) | EIRP Average (dBm) | EIRP Limit (dBm) | Margin (dB) |
| 5.0 | 19175 | 1907.5 | QPSK | 1 | 0 | 18.2 | 16.7 | 33.0 | -16.3 |
| | | | | 1 | 12 | 18.2 | 16.7 | 33.0 | -16.4 |
| | | | | 1 | 24 | 18.1 | 16.6 | 33.0 | -16.4 |
| | | | | 12 | 0 | 18.1 | 16.6 | 33.0 | -16.4 |
| | | | | 12 | 7 | 18.1 | 16.6 | 33.0 | -16.4 |
| | | | | 12 | 13 | 18.1 | 16.6 | 33.0 | -16.4 |
| | | | | 25 | 0 | 18.1 | 16.6 | 33.0 | -16.4 |
| | | | 16QAM | 1 | 0 | 17.9 | 16.4 | 33.0 | -16.6 |
| | | | | 1 | 12 | 17.8 | 16.3 | 33.0 | -16.7 |
| | | | | 1 | 24 | 17.8 | 16.3 | 33.0 | -16.7 |
| | | | | 12 | 0 | 17.8 | 16.3 | 33.0 | -16.8 |
| | | | | 12 | 7 | 17.7 | 16.2 | 33.0 | -16.8 |
| | | | | 12 | 13 | 17.7 | 16.2 | 33.0 | -16.8 |
| | | | | 25 | 0 | 17.7 | 16.2 | 33.0 | -16.8 |
| | | | 64QAM | 1 | 0 | 17.5 | 16.0 | 33.0 | -17.0 |
| | | | | 1 | 12 | 17.4 | 15.9 | 33.0 | -17.1 |
| | | | | 1 | 24 | 17.4 | 15.9 | 33.0 | -17.1 |
| | | | | 12 | 0 | 17.2 | 15.7 | 33.0 | -17.3 |
| | | | | 12 | 7 | 17.2 | 15.7 | 33.0 | -17.3 |
| | | | | 12 | 13 | 17.1 | 15.6 | 33.0 | -17.4 |
| | | | | 25 | 0 | 17.2 | 15.7 | 33.0 | -17.3 |

| Antenna gain (dBi) | | -1.50 | | | | | | | |
|--------------------|------------|-----------------|------------|---------|-----------|-------------------------|--------------------|------------------|-------------|
| Bandwidth | UL Channel | Frequency (MHz) | Modulation | RB Size | RB Offset | Conducted Average (dBm) | EIRP Average (dBm) | EIRP Limit (dBm) | Margin (dB) |
| 10.0 | 18650 | 1855.0 | QPSK | 1 | 0 | 18.4 | 16.9 | 33.0 | -16.1 |
| | | | | 1 | 25 | 18.1 | 16.6 | 33.0 | -16.5 |
| | | | | 1 | 49 | 18.3 | 16.8 | 33.0 | -16.2 |
| | | | | 25 | 0 | 18.3 | 16.8 | 33.0 | -16.2 |
| | | | | 25 | 12 | 18.2 | 16.7 | 33.0 | -16.4 |
| | | | | 25 | 25 | 18.1 | 16.6 | 33.0 | -16.4 |
| | | | | 50 | 0 | 18.2 | 16.7 | 33.0 | -16.3 |
| | | | 16QAM | 1 | 0 | 18.0 | 16.5 | 33.0 | -16.5 |
| | | | | 1 | 25 | 17.6 | 16.1 | 33.0 | -16.9 |
| | | | | 1 | 49 | 17.9 | 16.4 | 33.0 | -16.6 |
| | | | | 25 | 0 | 17.9 | 16.4 | 33.0 | -16.6 |
| | | | | 25 | 12 | 17.8 | 16.3 | 33.0 | -16.7 |
| | | | | 25 | 25 | 17.7 | 16.2 | 33.0 | -16.8 |
| | | | | 50 | 0 | 17.8 | 16.3 | 33.0 | -16.7 |
| | | | 64QAM | 1 | 0 | 17.9 | 16.4 | 33.0 | -16.6 |
| | | | | 1 | 25 | 17.6 | 16.1 | 33.0 | -16.9 |
| | | | | 1 | 49 | 17.5 | 16.0 | 33.0 | -17.0 |
| | | | | 25 | 0 | 17.1 | 15.6 | 33.0 | -17.4 |
| | | | | 25 | 12 | 17.2 | 15.7 | 33.0 | -17.3 |
| | | | | 25 | 25 | 17.0 | 15.5 | 33.0 | -17.5 |
| | | | | 50 | 0 | 17.1 | 15.6 | 33.0 | -17.4 |
| 10.0 | 18900 | 1880.0 | QPSK | 1 | 0 | 18.4 | 16.9 | 33.0 | -16.1 |
| | | | | 1 | 25 | 18.1 | 16.6 | 33.0 | -16.4 |
| | | | | 1 | 49 | 18.3 | 16.8 | 33.0 | -16.2 |
| | | | | 25 | 0 | 18.2 | 16.7 | 33.0 | -16.3 |
| | | | | 25 | 12 | 18.1 | 16.6 | 33.0 | -16.4 |
| | | | | 25 | 25 | 18.1 | 16.6 | 33.0 | -16.4 |
| | | | | 50 | 0 | 18.2 | 16.7 | 33.0 | -16.4 |
| | | | 16QAM | 1 | 0 | 18.3 | 16.8 | 33.0 | -16.2 |
| | | | | 1 | 25 | 18.0 | 16.5 | 33.0 | -16.5 |
| | | | | 1 | 49 | 18.1 | 16.6 | 33.0 | -16.4 |
| | | | | 25 | 0 | 17.8 | 16.3 | 33.0 | -16.7 |
| | | | | 25 | 12 | 17.7 | 16.2 | 33.0 | -16.8 |
| | | | | 25 | 25 | 17.7 | 16.2 | 33.0 | -16.8 |
| | | | | 50 | 0 | 17.7 | 16.2 | 33.0 | -16.8 |
| | | | 64QAM | 1 | 0 | 17.7 | 16.2 | 33.0 | -16.8 |
| | | | | 1 | 25 | 17.5 | 16.0 | 33.0 | -17.0 |
| | | | | 1 | 49 | 17.5 | 16.0 | 33.0 | -17.0 |
| | | | | 25 | 0 | 17.3 | 15.8 | 33.0 | -17.2 |
| | | | | 25 | 12 | 17.1 | 15.6 | 33.0 | -17.4 |
| | | | | 25 | 25 | 17.1 | 15.6 | 33.0 | -17.4 |
| | | | | 50 | 0 | 17.1 | 15.6 | 33.0 | -17.4 |

| Antenna gain (dBi) | | -1.50 | | | | | | | |
|--------------------|------------|-----------------|------------|---------|-----------|-------------------------|--------------------|------------------|-------------|
| Bandwidth | UL Channel | Frequency (MHz) | Modulation | RB Size | RB Offset | Conducted Average (dBm) | EIRP Average (dBm) | EIRP Limit (dBm) | Margin (dB) |
| 10.0 | 19150 | 1905.0 | QPSK | 1 | 0 | 18.2 | 16.7 | 33.0 | -16.3 |
| | | | | 1 | 25 | 18.1 | 16.6 | 33.0 | -16.4 |
| | | | | 1 | 49 | 18.1 | 16.6 | 33.0 | -16.5 |
| | | | | 25 | 0 | 18.2 | 16.7 | 33.0 | -16.3 |
| | | | | 25 | 12 | 18.2 | 16.7 | 33.0 | -16.3 |
| | | | | 25 | 25 | 18.1 | 16.6 | 33.0 | -16.4 |
| | | | | 50 | 0 | 18.2 | 16.7 | 33.0 | -16.4 |
| | | | 16QAM | 1 | 0 | 17.7 | 16.2 | 33.0 | -16.8 |
| | | | | 1 | 25 | 17.5 | 16.0 | 33.0 | -17.0 |
| | | | | 1 | 49 | 17.5 | 16.0 | 33.0 | -17.0 |
| | | | | 25 | 0 | 17.8 | 16.3 | 33.0 | -16.7 |
| | | | | 25 | 12 | 17.7 | 16.2 | 33.0 | -16.8 |
| | | | | 25 | 25 | 17.7 | 16.2 | 33.0 | -16.8 |
| | | | | 50 | 0 | 17.7 | 16.2 | 33.0 | -16.8 |
| | | | 64QAM | 1 | 0 | 17.3 | 15.8 | 33.0 | -17.2 |
| | | | | 1 | 25 | 17.3 | 15.8 | 33.0 | -17.2 |
| | | | | 1 | 49 | 17.2 | 15.7 | 33.0 | -17.3 |
| | | | | 25 | 0 | 17.2 | 15.7 | 33.0 | -17.3 |
| | | | | 25 | 12 | 17.1 | 15.6 | 33.0 | -17.4 |
| | | | | 25 | 25 | 17.1 | 15.6 | 33.0 | -17.4 |
| | | | | 50 | 0 | 17.1 | 15.6 | 33.0 | -17.4 |

| Antenna gain (dBi) | | -1.50 | | | | | | | |
|--------------------|------------|-----------------|------------|---------|-----------|-------------------------|--------------------|------------------|-------------|
| Bandwidth | UL Channel | Frequency (MHz) | Modulation | RB Size | RB Offset | Conducted Average (dBm) | EIRP Average (dBm) | EIRP Limit (dBm) | Margin (dB) |
| 15.0 | 18675 | 1857.5 | QPSK | 1 | 0 | 18.4 | 16.9 | 33.0 | -16.1 |
| | | | | 1 | 37 | 18.1 | 16.6 | 33.0 | -16.4 |
| | | | | 1 | 74 | 18.1 | 16.6 | 33.0 | -16.4 |
| | | | | 36 | 0 | 18.2 | 16.7 | 33.0 | -16.3 |
| | | | | 36 | 20 | 18.2 | 16.7 | 33.0 | -16.3 |
| | | | | 36 | 39 | 18.2 | 16.7 | 33.0 | -16.3 |
| | | | 75 | 0 | 18.2 | 16.7 | 33.0 | -16.3 | |
| | | | 16QAM | 1 | 0 | 18.3 | 16.8 | 33.0 | -16.2 |
| | | | | 1 | 37 | 18.0 | 16.5 | 33.0 | -16.5 |
| | | | | 1 | 74 | 18.0 | 16.5 | 33.0 | -16.5 |
| | | | | 36 | 0 | 17.7 | 16.2 | 33.0 | -16.8 |
| | | | | 36 | 20 | 17.7 | 16.2 | 33.0 | -16.8 |
| | | | | 36 | 39 | 17.7 | 16.2 | 33.0 | -16.8 |
| | | | 75 | 0 | 17.8 | 16.3 | 33.0 | -16.7 | |
| | | | 64QAM | 1 | 0 | 17.6 | 16.1 | 33.0 | -16.9 |
| | | | | 1 | 37 | 17.4 | 15.9 | 33.0 | -17.1 |
| | | | | 1 | 74 | 17.5 | 16.0 | 33.0 | -17.0 |
| | | | | 36 | 0 | 17.3 | 15.8 | 33.0 | -17.2 |
| | | | | 36 | 20 | 17.2 | 15.7 | 33.0 | -17.3 |
| | | | | 36 | 39 | 17.2 | 15.7 | 33.0 | -17.3 |
| | | | 75 | 0 | 17.2 | 15.7 | 33.0 | -17.3 | |
| 15.0 | 18900 | 1880.0 | QPSK | 1 | 0 | 18.3 | 16.8 | 33.0 | -16.2 |
| | | | | 1 | 37 | 18.2 | 16.7 | 33.0 | -16.3 |
| | | | | 1 | 74 | 18.1 | 16.6 | 33.0 | -16.4 |
| | | | | 36 | 0 | 18.2 | 16.7 | 33.0 | -16.3 |
| | | | | 36 | 20 | 18.2 | 16.7 | 33.0 | -16.3 |
| | | | | 36 | 39 | 18.1 | 16.6 | 33.0 | -16.4 |
| | | | 75 | 0 | 18.2 | 16.7 | 33.0 | -16.3 | |
| | | | 16QAM | 1 | 0 | 18.2 | 16.7 | 33.0 | -16.3 |
| | | | | 1 | 37 | 18.0 | 16.5 | 33.0 | -16.5 |
| | | | | 1 | 74 | 18.0 | 16.5 | 33.0 | -16.5 |
| | | | | 36 | 0 | 17.9 | 16.4 | 33.0 | -16.6 |
| | | | | 36 | 20 | 17.8 | 16.3 | 33.0 | -16.7 |
| | | | | 36 | 39 | 17.7 | 16.2 | 33.0 | -16.8 |
| | | | 75 | 0 | 17.8 | 16.3 | 33.0 | -16.8 | |
| | | | 64QAM | 1 | 0 | 17.5 | 16.0 | 33.0 | -17.0 |
| | | | | 1 | 37 | 17.4 | 15.9 | 33.0 | -17.1 |
| | | | | 1 | 74 | 17.2 | 15.7 | 33.0 | -17.3 |
| | | | | 36 | 0 | 17.2 | 15.7 | 33.0 | -17.3 |
| | | | | 36 | 20 | 17.1 | 15.6 | 33.0 | -17.4 |
| | | | | 36 | 39 | 17.1 | 15.6 | 33.0 | -17.4 |
| | | | 75 | 0 | 17.1 | 15.6 | 33.0 | -17.4 | |

| Antenna gain (dBi) | | -1.50 | | | | | | | |
|--------------------|------------|-----------------|------------|---------|-----------|-------------------------|--------------------|------------------|-------------|
| Bandwidth | UL Channel | Frequency (MHz) | Modulation | RB Size | RB Offset | Conducted Average (dBm) | EIRP Average (dBm) | EIRP Limit (dBm) | Margin (dB) |
| 15.0 | 19125 | 1902.5 | QPSK | 1 | 0 | 18.4 | 16.9 | 33.0 | -16.1 |
| | | | | 1 | 37 | 18.1 | 16.6 | 33.0 | -16.4 |
| | | | | 1 | 74 | 18.1 | 16.6 | 33.0 | -16.4 |
| | | | | 36 | 0 | 18.3 | 16.8 | 33.0 | -16.2 |
| | | | | 36 | 20 | 18.2 | 16.7 | 33.0 | -16.3 |
| | | | | 36 | 39 | 18.1 | 16.6 | 33.0 | -16.4 |
| | | | | 75 | 0 | 18.2 | 16.7 | 33.0 | -16.3 |
| | | | 16QAM | 1 | 0 | 17.8 | 16.3 | 33.0 | -16.7 |
| | | | | 1 | 37 | 17.6 | 16.1 | 33.0 | -16.9 |
| | | | | 1 | 74 | 17.5 | 16.0 | 33.0 | -17.0 |
| | | | | 36 | 0 | 17.8 | 16.3 | 33.0 | -16.7 |
| | | | | 36 | 20 | 17.8 | 16.3 | 33.0 | -16.8 |
| | | | | 36 | 39 | 17.7 | 16.2 | 33.0 | -16.8 |
| | | | | 75 | 0 | 17.7 | 16.2 | 33.0 | -16.8 |
| | | | 64QAM | 1 | 0 | 17.6 | 16.1 | 33.0 | -16.9 |
| | | | | 1 | 37 | 17.5 | 16.0 | 33.0 | -17.0 |
| | | | | 1 | 74 | 17.3 | 15.8 | 33.0 | -17.2 |
| | | | | 36 | 0 | 17.3 | 15.8 | 33.0 | -17.2 |
| | | | | 36 | 20 | 17.2 | 15.7 | 33.0 | -17.3 |
| | | | | 36 | 39 | 17.3 | 15.8 | 33.0 | -17.2 |
| | | | | 75 | 0 | 17.1 | 15.6 | 33.0 | -17.4 |

| Antenna gain (dBi) | | -1.50 | | | | | | | |
|--------------------|------------|-----------------|------------|---------|-----------|-------------------------|--------------------|------------------|-------------|
| Bandwidth | UL Channel | Frequency (MHz) | Modulation | RB Size | RB Offset | Conducted Average (dBm) | EIRP Average (dBm) | EIRP Limit (dBm) | Margin (dB) |
| 20.0 | 18700 | 1860.0 | QPSK | 1 | 0 | 18.5 | 17.0 | 33.0 | -16.1 |
| | | | | 1 | 49 | 18.1 | 16.6 | 33.0 | -16.4 |
| | | | | 1 | 99 | 18.0 | 16.5 | 33.0 | -16.5 |
| | | | | 50 | 0 | 18.3 | 16.8 | 33.0 | -16.2 |
| | | | | 50 | 24 | 18.2 | 16.7 | 33.0 | -16.4 |
| | | | | 50 | 50 | 18.1 | 16.6 | 33.0 | -16.4 |
| | | | | 100 | 0 | 18.2 | 16.7 | 33.0 | -16.3 |
| | | | 16QAM | 1 | 0 | 18.4 | 16.9 | 33.0 | -16.1 |
| | | | | 1 | 49 | 18.0 | 16.5 | 33.0 | -16.5 |
| | | | | 1 | 99 | 18.0 | 16.5 | 33.0 | -16.5 |
| | | | | 50 | 0 | 17.8 | 16.3 | 33.0 | -16.7 |
| | | | | 50 | 24 | 17.7 | 16.2 | 33.0 | -16.8 |
| | | | | 50 | 50 | 17.7 | 16.2 | 33.0 | -16.9 |
| | | | | 100 | 0 | 17.7 | 16.2 | 33.0 | -16.8 |
| | | | 64QAM | 1 | 0 | 17.5 | 16.0 | 33.0 | -17.0 |
| | | | | 1 | 49 | 17.3 | 15.8 | 33.0 | -17.2 |
| | | | | 1 | 99 | 17.4 | 15.9 | 33.0 | -17.1 |
| | | | | 50 | 0 | 17.1 | 15.6 | 33.0 | -17.4 |
| | | | | 50 | 24 | 17.2 | 15.7 | 33.0 | -17.3 |
| | | | | 50 | 50 | 17.1 | 15.6 | 33.0 | -17.4 |
| | | | | 100 | 0 | 17.1 | 15.6 | 33.0 | -17.4 |
| 20.0 | 18900 | 1880.0 | QPSK | 1 | 0 | 18.4 | 16.9 | 33.0 | -16.1 |
| | | | | 1 | 49 | 18.1 | 16.6 | 33.0 | -16.4 |
| | | | | 1 | 99 | 18.2 | 16.7 | 33.0 | -16.3 |
| | | | | 50 | 0 | 18.3 | 16.8 | 33.0 | -16.2 |
| | | | | 50 | 24 | 18.2 | 16.7 | 33.0 | -16.3 |
| | | | | 50 | 50 | 18.1 | 16.6 | 33.0 | -16.4 |
| | | | | 100 | 0 | 18.2 | 16.7 | 33.0 | -16.3 |
| | | | 16QAM | 1 | 0 | 18.4 | 16.9 | 33.0 | -16.1 |
| | | | | 1 | 49 | 18.1 | 16.6 | 33.0 | -16.4 |
| | | | | 1 | 99 | 18.3 | 16.8 | 33.0 | -16.2 |
| | | | | 50 | 0 | 17.8 | 16.3 | 33.0 | -16.7 |
| | | | | 50 | 24 | 17.8 | 16.3 | 33.0 | -16.8 |
| | | | | 50 | 50 | 17.7 | 16.2 | 33.0 | -16.8 |
| | | | | 100 | 0 | 17.8 | 16.3 | 33.0 | -16.7 |
| | | | 64QAM | 1 | 0 | 17.8 | 16.3 | 33.0 | -16.7 |
| | | | | 1 | 49 | 17.0 | 15.5 | 33.0 | -17.5 |
| | | | | 1 | 99 | 17.6 | 16.1 | 33.0 | -16.9 |
| | | | | 50 | 0 | 17.2 | 15.7 | 33.0 | -17.3 |
| | | | | 50 | 24 | 17.1 | 15.6 | 33.0 | -17.4 |
| | | | | 50 | 50 | 17.1 | 15.6 | 33.0 | -17.4 |
| | | | | 100 | 0 | 17.1 | 15.6 | 33.0 | -17.4 |

| Antenna gain (dBi) | | -1.50 | | | | | | | |
|--------------------|------------|--------|------------|---------|-----------|-------------------------|--------------------|------------------|-------------|
| Bandwidth | UL Channel | -1.5 | Modulation | RB Size | RB Offset | Conducted Average (dBm) | EIRP Average (dBm) | EIRP Limit (dBm) | Margin (dB) |
| 20.0 | 19100 | 1900.0 | QPSK | 1 | 0 | 18.2 | 16.7 | 33.0 | -16.3 |
| | | | | 1 | 49 | 18.1 | 16.6 | 33.0 | -16.4 |
| | | | | 1 | 99 | 18.2 | 16.7 | 33.0 | -16.3 |
| | | | | 50 | 0 | 18.3 | 16.8 | 33.0 | -16.2 |
| | | | | 50 | 24 | 18.2 | 16.7 | 33.0 | -16.3 |
| | | | | 50 | 50 | 18.1 | 16.6 | 33.0 | -16.4 |
| | | | 16QAM | 100 | 0 | 18.2 | 16.7 | 33.0 | -16.3 |
| | | | | 1 | 0 | 18.4 | 16.9 | 33.0 | -16.1 |
| | | | | 1 | 49 | 18.1 | 16.6 | 33.0 | -16.4 |
| | | | | 1 | 99 | 18.3 | 16.8 | 33.0 | -16.2 |
| | | | | 50 | 0 | 17.8 | 16.3 | 33.0 | -16.7 |
| | | | | 50 | 24 | 17.8 | 16.3 | 33.0 | -16.8 |
| | | | 64QAM | 50 | 50 | 17.7 | 16.2 | 33.0 | -16.8 |
| | | | | 100 | 0 | 17.8 | 16.3 | 33.0 | -16.7 |
| | | | | 1 | 0 | 17.5 | 16.0 | 33.0 | -17.0 |
| | | | | 1 | 49 | 17.4 | 15.9 | 33.0 | -17.1 |
| | | | | 1 | 99 | 17.3 | 15.8 | 33.0 | -17.2 |
| | | | | 50 | 0 | 17.2 | 15.7 | 33.0 | -17.3 |
| | | | | 50 | 24 | 17.2 | 15.7 | 33.0 | -17.3 |
| | | | | 50 | 50 | 17.2 | 15.7 | 33.0 | -17.3 |
| | | | 100 | 0 | 17.2 | 15.7 | 33.0 | -17.3 | |

LTE Band 4

| Antenna gain (dBi) | | -2.30 | | | | | | | | | | |
|--------------------|------------|-----------------|------------|---------|-----------|-------------------------|--------------------|------------------|-------------|------|------|-------|
| Bandwidth | UL Channel | Frequency (MHz) | Modulation | RB Size | RB Offset | Conducted Average (dBm) | EIRP Average (dBm) | EIRP Limit (dBm) | Margin (dB) | | | |
| 1.4 | 19957 | 1710.7 | QPSK | 1 | 0 | 19.7 | 17.4 | 33.0 | -15.6 | | | |
| | | | | 1 | 3 | 19.8 | 17.5 | 33.0 | -15.5 | | | |
| | | | | 1 | 5 | 19.7 | 17.4 | 33.0 | -15.6 | | | |
| | | | | 3 | 0 | 19.7 | 17.4 | 33.0 | -15.6 | | | |
| | | | | 3 | 1 | 19.8 | 17.5 | 33.0 | -15.5 | | | |
| | | | | 3 | 3 | 19.8 | 17.5 | 33.0 | -15.5 | | | |
| | | | 16QAM | 6 | 0 | 19.7 | 17.4 | 33.0 | -15.6 | | | |
| | | | | 1 | 0 | 19.3 | 17.0 | 33.0 | -16.1 | | | |
| | | | | 1 | 3 | 19.3 | 17.0 | 33.0 | -16.0 | | | |
| | | | | 1 | 5 | 19.3 | 17.0 | 33.0 | -16.1 | | | |
| | | | | 3 | 0 | 19.4 | 17.1 | 33.0 | -15.9 | | | |
| | | | | 3 | 1 | 19.5 | 17.2 | 33.0 | -15.8 | | | |
| | | | 64QAM | 3 | 3 | 19.5 | 17.2 | 33.0 | -15.8 | | | |
| | | | | 6 | 0 | 19.5 | 17.2 | 33.0 | -15.9 | | | |
| | | | | 1 | 0 | 18.9 | 16.6 | 33.0 | -16.4 | | | |
| | | | | 1 | 3 | 19.0 | 16.7 | 33.0 | -16.3 | | | |
| | | | | 1 | 5 | 18.9 | 16.6 | 33.0 | -16.4 | | | |
| | | | | 3 | 0 | 18.9 | 16.6 | 33.0 | -16.4 | | | |
| | | | 1.4 | 20175 | 1732.5 | QPSK | 3 | 1 | 18.8 | 16.5 | 33.0 | -16.5 |
| | | | | | | | 3 | 3 | 18.8 | 16.5 | 33.0 | -16.5 |
| | | | | | | | 6 | 0 | 18.7 | 16.4 | 33.0 | -16.6 |
| | | | | | | | 1 | 0 | 19.8 | 17.5 | 33.0 | -15.5 |
| | | | | | | | 1 | 3 | 19.9 | 17.6 | 33.0 | -15.5 |
| | | | | | | | 1 | 5 | 19.8 | 17.5 | 33.0 | -15.5 |
| 16QAM | 3 | 0 | | | | 19.8 | 17.5 | 33.0 | -15.5 | | | |
| | 3 | 1 | | | | 19.9 | 17.6 | 33.0 | -15.5 | | | |
| | 3 | 3 | | | | 19.8 | 17.5 | 33.0 | -15.5 | | | |
| | 6 | 0 | | | | 19.8 | 17.5 | 33.0 | -15.5 | | | |
| | 1 | 0 | | | | 19.7 | 17.4 | 33.0 | -15.6 | | | |
| | 1 | 3 | | | | 19.7 | 17.4 | 33.0 | -15.6 | | | |
| 64QAM | 1 | 5 | | | | 19.6 | 17.3 | 33.0 | -15.7 | | | |
| | 3 | 0 | | | | 19.5 | 17.2 | 33.0 | -15.8 | | | |
| | 3 | 1 | | | | 19.5 | 17.2 | 33.0 | -15.8 | | | |
| | 3 | 3 | | | | 19.5 | 17.2 | 33.0 | -15.8 | | | |
| | 6 | 0 | | | | 19.2 | 16.9 | 33.0 | -16.1 | | | |
| | 1 | 0 | | | | 19.0 | 16.7 | 33.0 | -16.3 | | | |
| 64QAM | 1 | 3 | | | | 19.2 | 16.9 | 33.0 | -16.1 | | | |
| | 1 | 5 | | | | 19.2 | 16.9 | 33.0 | -16.1 | | | |
| | 3 | 0 | | | | 18.9 | 16.6 | 33.0 | -16.4 | | | |
| | 3 | 1 | | | | 18.8 | 16.5 | 33.0 | -16.5 | | | |
| | 3 | 3 | | | | 18.9 | 16.6 | 33.0 | -16.4 | | | |
| | 6 | 0 | | | | 18.8 | 16.5 | 33.0 | -16.5 | | | |

| Antenna gain (dBi) | | -2.30 | | | | | | | |
|--------------------|------------|-----------------|------------|---------|-----------|-------------------------|--------------------|------------------|-------------|
| Bandwidth | UL Channel | Frequency (MHz) | Modulation | RB Size | RB Offset | Conducted Average (dBm) | EIRP Average (dBm) | EIRP Limit (dBm) | Margin (dB) |
| 1.4 | 20393 | 1754.3 | QPSK | 1 | 0 | 19.8 | 17.5 | 33.0 | -15.5 |
| | | | | 1 | 3 | 19.9 | 17.6 | 33.0 | -15.5 |
| | | | | 1 | 5 | 19.8 | 17.5 | 33.0 | -15.5 |
| | | | | 3 | 0 | 19.8 | 17.5 | 33.0 | -15.5 |
| | | | | 3 | 1 | 19.8 | 17.5 | 33.0 | -15.5 |
| | | | | 3 | 3 | 19.8 | 17.5 | 33.0 | -15.5 |
| | | | 16QAM | 6 | 0 | 19.8 | 17.5 | 33.0 | -15.5 |
| | | | | 1 | 0 | 19.4 | 17.1 | 33.0 | -15.9 |
| | | | | 1 | 3 | 19.5 | 17.2 | 33.0 | -15.8 |
| | | | | 1 | 5 | 19.4 | 17.1 | 33.0 | -15.9 |
| | | | | 3 | 0 | 19.4 | 17.1 | 33.0 | -15.9 |
| | | | | 3 | 1 | 19.4 | 17.1 | 33.0 | -15.9 |
| | | | 64QAM | 3 | 3 | 19.4 | 17.1 | 33.0 | -15.9 |
| | | | | 6 | 0 | 19.4 | 17.1 | 33.0 | -15.9 |
| | | | | 1 | 0 | 19.2 | 16.9 | 33.0 | -16.1 |
| | | | | 1 | 3 | 19.2 | 16.9 | 33.0 | -16.1 |
| | | | | 1 | 5 | 19.1 | 16.8 | 33.0 | -16.2 |
| | | | | 3 | 0 | 19.0 | 16.7 | 33.0 | -16.3 |
| | | | | 3 | 1 | 18.9 | 16.6 | 33.0 | -16.4 |
| | | | | 3 | 3 | 18.9 | 16.6 | 33.0 | -16.4 |
| | | | | 6 | 0 | 18.9 | 16.6 | 33.0 | -16.4 |

| Antenna gain (dBi) | | -2.30 | | | | | | | |
|--------------------|------------|-----------------|------------|---------|-----------|-------------------------|--------------------|------------------|-------------|
| Bandwidth | UL Channel | Frequency (MHz) | Modulation | RB Size | RB Offset | Conducted Average (dBm) | EIRP Average (dBm) | EIRP Limit (dBm) | Margin (dB) |
| 3.0 | 19965 | 1711.5 | QPSK | 1 | 0 | 19.8 | 17.5 | 33.0 | -15.5 |
| | | | | 1 | 8 | 19.8 | 17.5 | 33.0 | -15.5 |
| | | | | 1 | 14 | 19.7 | 17.4 | 33.0 | -15.6 |
| | | | | 8 | 0 | 19.9 | 17.6 | 33.0 | -15.4 |
| | | | | 8 | 4 | 19.9 | 17.6 | 33.0 | -15.4 |
| | | | | 8 | 7 | 19.7 | 17.4 | 33.0 | -15.6 |
| | | | 16QAM | 15 | 0 | 19.7 | 17.4 | 33.0 | -15.6 |
| | | | | 1 | 0 | 19.4 | 17.1 | 33.0 | -15.9 |
| | | | | 1 | 8 | 19.3 | 17.0 | 33.0 | -16.0 |
| | | | | 1 | 14 | 19.2 | 16.9 | 33.0 | -16.1 |
| | | | | 8 | 0 | 19.4 | 17.1 | 33.0 | -15.9 |
| | | | | 8 | 4 | 19.4 | 17.1 | 33.0 | -15.9 |
| | | | 64QAM | 8 | 7 | 19.3 | 17.0 | 33.0 | -16.0 |
| | | | | 15 | 0 | 19.2 | 16.9 | 33.0 | -16.1 |
| | | | | 1 | 0 | 18.9 | 16.6 | 33.0 | -16.4 |
| | | | | 1 | 8 | 18.8 | 16.5 | 33.0 | -16.5 |
| | | | | 1 | 14 | 18.8 | 16.5 | 33.0 | -16.5 |
| | | | | 8 | 0 | 18.8 | 16.5 | 33.0 | -16.5 |
| 3.0 | 20175 | 1732.5 | QPSK | 8 | 4 | 18.8 | 16.5 | 33.0 | -16.5 |
| | | | | 8 | 7 | 18.7 | 16.4 | 33.0 | -16.6 |
| | | | | 15 | 0 | 18.7 | 16.4 | 33.0 | -16.6 |
| | | | | 1 | 0 | 20.0 | 17.7 | 33.0 | -15.3 |
| | | | | 1 | 8 | 20.0 | 17.7 | 33.0 | -15.3 |
| | | | | 1 | 14 | 20.0 | 17.7 | 33.0 | -15.3 |
| | | | 16QAM | 8 | 0 | 20.1 | 17.8 | 33.0 | -15.2 |
| | | | | 8 | 4 | 20.1 | 17.8 | 33.0 | -15.2 |
| | | | | 8 | 7 | 20.1 | 17.8 | 33.0 | -15.2 |
| | | | | 15 | 0 | 20.1 | 17.8 | 33.0 | -15.2 |
| | | | | 1 | 0 | 19.5 | 17.2 | 33.0 | -15.8 |
| | | | | 1 | 8 | 19.5 | 17.2 | 33.0 | -15.8 |
| | | | 64QAM | 1 | 14 | 19.5 | 17.2 | 33.0 | -15.8 |
| | | | | 8 | 0 | 19.7 | 17.4 | 33.0 | -15.6 |
| | | | | 8 | 4 | 19.7 | 17.4 | 33.0 | -15.6 |
| | | | | 8 | 7 | 19.6 | 17.3 | 33.0 | -15.7 |
| | | | | 15 | 0 | 19.7 | 17.4 | 33.0 | -15.6 |
| | | | | 1 | 0 | 18.6 | 16.3 | 33.0 | -16.7 |
| 64QAM | 1 | 8 | 18.5 | 16.2 | 33.0 | -16.8 | | | |
| | 1 | 14 | 18.5 | 16.2 | 33.0 | -16.8 | | | |
| | 8 | 0 | 18.7 | 16.4 | 33.0 | -16.6 | | | |
| | 8 | 4 | 18.8 | 16.5 | 33.0 | -16.5 | | | |
| | 8 | 7 | 18.7 | 16.4 | 33.0 | -16.6 | | | |
| | 15 | 0 | 18.7 | 16.4 | 33.0 | -16.6 | | | |

| Antenna gain (dBi) | | -2.30 | | | | | | | |
|--------------------|------------|-----------------|------------|---------|-----------|-------------------------|--------------------|------------------|-------------|
| Bandwidth | UL Channel | Frequency (MHz) | Modulation | RB Size | RB Offset | Conducted Average (dBm) | EIRP Average (dBm) | EIRP Limit (dBm) | Margin (dB) |
| 3.0 | 20385 | 1753.5 | QPSK | 1 | 0 | 19.8 | 17.5 | 33.0 | -15.5 |
| | | | | 1 | 8 | 19.9 | 17.6 | 33.0 | -15.4 |
| | | | | 1 | 14 | 19.8 | 17.5 | 33.0 | -15.5 |
| | | | | 8 | 0 | 19.9 | 17.6 | 33.0 | -15.5 |
| | | | | 8 | 4 | 19.9 | 17.6 | 33.0 | -15.5 |
| | | | | 8 | 7 | 19.9 | 17.6 | 33.0 | -15.5 |
| | | | | 15 | 0 | 19.8 | 17.5 | 33.0 | -15.5 |
| | | | 16QAM | 1 | 0 | 19.3 | 17.0 | 33.0 | -16.0 |
| | | | | 1 | 8 | 19.4 | 17.1 | 33.0 | -15.9 |
| | | | | 1 | 14 | 19.2 | 16.9 | 33.0 | -16.1 |
| | | | | 8 | 0 | 19.5 | 17.2 | 33.0 | -15.8 |
| | | | | 8 | 4 | 19.5 | 17.2 | 33.0 | -15.8 |
| | | | | 8 | 7 | 19.5 | 17.2 | 33.0 | -15.8 |
| | | | | 15 | 0 | 19.4 | 17.1 | 33.0 | -15.9 |
| | | | 64QAM | 1 | 0 | 19.1 | 16.8 | 33.0 | -16.2 |
| | | | | 1 | 8 | 19.2 | 16.9 | 33.0 | -16.1 |
| | | | | 1 | 14 | 19.2 | 16.9 | 33.0 | -16.1 |
| | | | | 8 | 0 | 18.9 | 16.6 | 33.0 | -16.4 |
| | | | | 8 | 4 | 18.9 | 16.6 | 33.0 | -16.4 |
| | | | | 8 | 7 | 18.9 | 16.6 | 33.0 | -16.4 |
| | | | | 15 | 0 | 18.9 | 16.6 | 33.0 | -16.4 |

| Antenna gain (dBi) | | -2.30 | | | | | | | |
|--------------------|------------|-----------------|------------|---------|-----------|-------------------------|--------------------|------------------|-------------|
| Bandwidth | UL Channel | Frequency (MHz) | Modulation | RB Size | RB Offset | Conducted Average (dBm) | EIRP Average (dBm) | EIRP Limit (dBm) | Margin (dB) |
| 5.0 | 19975 | 1712.5 | QPSK | 1 | 0 | 20.0 | 17.7 | 33.0 | -15.4 |
| | | | | 1 | 12 | 19.8 | 17.5 | 33.0 | -15.6 |
| | | | | 1 | 24 | 19.7 | 17.4 | 33.0 | -15.6 |
| | | | | 12 | 0 | 19.9 | 17.6 | 33.0 | -15.5 |
| | | | | 12 | 7 | 19.8 | 17.5 | 33.0 | -15.6 |
| | | | | 12 | 13 | 19.7 | 17.4 | 33.0 | -15.6 |
| | | | | 25 | 0 | 19.7 | 17.4 | 33.0 | -15.6 |
| | | | 16QAM | 1 | 0 | 19.5 | 17.2 | 33.0 | -15.8 |
| | | | | 1 | 12 | 19.3 | 17.0 | 33.0 | -16.0 |
| | | | | 1 | 24 | 19.3 | 17.0 | 33.0 | -16.0 |
| | | | | 12 | 0 | 19.5 | 17.2 | 33.0 | -15.9 |
| | | | | 12 | 7 | 19.3 | 17.0 | 33.0 | -16.0 |
| | | | | 12 | 13 | 19.3 | 17.0 | 33.0 | -16.0 |
| | | | | 25 | 0 | 19.2 | 16.9 | 33.0 | -16.1 |
| | | | 64QAM | 1 | 0 | 19.0 | 16.7 | 33.0 | -16.3 |
| | | | | 1 | 12 | 18.8 | 16.5 | 33.0 | -16.5 |
| | | | | 1 | 24 | 18.8 | 16.5 | 33.0 | -16.5 |
| | | | | 12 | 0 | 18.7 | 16.4 | 33.0 | -16.6 |
| | | | | 12 | 7 | 18.6 | 16.3 | 33.0 | -16.7 |
| | | | | 12 | 13 | 18.6 | 16.3 | 33.0 | -16.7 |
| | | | | 25 | 0 | 18.5 | 16.2 | 33.0 | -16.8 |
| 5.0 | 20175 | 1732.5 | QPSK | 1 | 0 | 19.9 | 17.6 | 33.0 | -15.4 |
| | | | | 1 | 12 | 19.8 | 17.5 | 33.0 | -15.5 |
| | | | | 1 | 24 | 19.9 | 17.6 | 33.0 | -15.4 |
| | | | | 12 | 0 | 19.9 | 17.6 | 33.0 | -15.4 |
| | | | | 12 | 7 | 19.9 | 17.6 | 33.0 | -15.4 |
| | | | | 12 | 13 | 19.8 | 17.5 | 33.0 | -15.5 |
| | | | | 25 | 0 | 19.9 | 17.6 | 33.0 | -15.4 |
| | | | 16QAM | 1 | 0 | 20.0 | 17.7 | 33.0 | -15.3 |
| | | | | 1 | 2 | 19.9 | 17.6 | 33.0 | -15.4 |
| | | | | 1 | 5 | 19.9 | 17.6 | 33.0 | -15.4 |
| | | | | 3 | 0 | 19.6 | 17.3 | 33.0 | -15.7 |
| | | | | 3 | 1 | 19.6 | 17.3 | 33.0 | -15.7 |
| | | | | 3 | 2 | 19.5 | 17.2 | 33.0 | -15.8 |
| | | | | 6 | 0 | 19.5 | 17.2 | 33.0 | -15.9 |
| | | | 64QAM | 1 | 0 | 19.0 | 16.7 | 33.0 | -16.3 |
| | | | | 1 | 12 | 19.0 | 16.7 | 33.0 | -16.3 |
| | | | | 1 | 24 | 18.9 | 16.6 | 33.0 | -16.4 |
| | | | | 12 | 0 | 18.7 | 16.4 | 33.0 | -16.6 |
| | | | | 12 | 7 | 18.7 | 16.4 | 33.0 | -16.6 |
| | | | | 12 | 13 | 18.7 | 16.4 | 33.0 | -16.6 |
| | | | | 25 | 0 | 18.6 | 16.3 | 33.0 | -16.7 |

| Antenna gain (dBi) | | -2.30 | | | | | | | |
|--------------------|------------|-----------------|------------|---------|-----------|-------------------------|--------------------|------------------|-------------|
| Bandwidth | UL Channel | Frequency (MHz) | Modulation | RB Size | RB Offset | Conducted Average (dBm) | EIRP Average (dBm) | EIRP Limit (dBm) | Margin (dB) |
| 5.0 | 20375 | 1752.5 | QPSK | 1 | 0 | 20.0 | 17.7 | 33.0 | -15.3 |
| | | | | 1 | 12 | 19.9 | 17.6 | 33.0 | -15.4 |
| | | | | 1 | 24 | 20.0 | 17.7 | 33.0 | -15.3 |
| | | | | 12 | 0 | 19.9 | 17.6 | 33.0 | -15.5 |
| | | | | 12 | 7 | 19.9 | 17.6 | 33.0 | -15.4 |
| | | | | 12 | 13 | 19.8 | 17.5 | 33.0 | -15.5 |
| | | | | 25 | 0 | 19.9 | 17.6 | 33.0 | -15.5 |
| | | | 16QAM | 1 | 0 | 19.6 | 17.3 | 33.0 | -15.7 |
| | | | | 1 | 12 | 19.5 | 17.2 | 33.0 | -15.8 |
| | | | | 1 | 24 | 19.5 | 17.2 | 33.0 | -15.8 |
| | | | | 12 | 0 | 19.5 | 17.2 | 33.0 | -15.8 |
| | | | | 12 | 7 | 19.5 | 17.2 | 33.0 | -15.8 |
| | | | | 12 | 13 | 19.5 | 17.2 | 33.0 | -15.8 |
| | | | | 25 | 0 | 19.4 | 17.1 | 33.0 | -15.9 |
| | | | 64QAM | 1 | 0 | 19.0 | 16.7 | 33.0 | -16.3 |
| | | | | 1 | 12 | 19.0 | 16.7 | 33.0 | -16.3 |
| | | | | 1 | 24 | 19.1 | 16.8 | 33.0 | -16.2 |
| | | | | 12 | 0 | 18.8 | 16.5 | 33.0 | -16.5 |
| | | | | 12 | 7 | 18.7 | 16.4 | 33.0 | -16.6 |
| | | | | 12 | 13 | 18.7 | 16.4 | 33.0 | -16.6 |
| | | | | 25 | 0 | 18.7 | 16.4 | 33.0 | -16.6 |

| Antenna gain (dBi) | | -2.30 | | | | | | | |
|--------------------|------------|-----------------|------------|---------|-----------|-------------------------|--------------------|------------------|-------------|
| Bandwidth | UL Channel | Frequency (MHz) | Modulation | RB Size | RB Offset | Conducted Average (dBm) | EIRP Average (dBm) | EIRP Limit (dBm) | Margin (dB) |
| 10.0 | 20000 | 1715.0 | QPSK | 1 | 0 | 19.9 | 17.6 | 33.0 | -15.4 |
| | | | | 1 | 25 | 19.7 | 17.4 | 33.0 | -15.6 |
| | | | | 1 | 49 | 19.6 | 17.3 | 33.0 | -15.7 |
| | | | | 25 | 0 | 19.8 | 17.5 | 33.0 | -15.5 |
| | | | | 25 | 12 | 19.8 | 17.5 | 33.0 | -15.6 |
| | | | | 25 | 25 | 19.7 | 17.4 | 33.0 | -15.6 |
| | | | 50 | 0 | 19.8 | 17.5 | 33.0 | -15.5 | |
| | | | 16QAM | 1 | 0 | 19.4 | 17.1 | 33.0 | -15.9 |
| | | | | 1 | 25 | 19.2 | 16.9 | 33.0 | -16.1 |
| | | | | 1 | 49 | 19.2 | 16.9 | 33.0 | -16.1 |
| | | | | 25 | 0 | 19.4 | 17.1 | 33.0 | -15.9 |
| | | | | 25 | 12 | 19.4 | 17.1 | 33.0 | -15.9 |
| | | | | 25 | 25 | 19.3 | 17.0 | 33.0 | -16.0 |
| | | | 50 | 0 | 19.3 | 17.0 | 33.0 | -16.0 | |
| | | | 64QAM | 1 | 0 | 19.2 | 16.9 | 33.0 | -16.1 |
| | | | | 1 | 25 | 18.9 | 16.6 | 33.0 | -16.4 |
| | | | | 1 | 49 | 18.9 | 16.6 | 33.0 | -16.4 |
| | | | | 25 | 0 | 18.6 | 16.3 | 33.0 | -16.7 |
| | | | | 25 | 12 | 18.5 | 16.2 | 33.0 | -16.8 |
| | | | | 25 | 25 | 18.5 | 16.2 | 33.0 | -16.8 |
| | | | 50 | 0 | 18.5 | 16.2 | 33.0 | -16.8 | |
| 10.0 | 20175 | 1732.5 | QPSK | 1 | 0 | 20.0 | 17.7 | 33.0 | -15.3 |
| | | | | 1 | 25 | 19.8 | 17.5 | 33.0 | -15.5 |
| | | | | 1 | 49 | 19.8 | 17.5 | 33.0 | -15.5 |
| | | | | 25 | 0 | 19.9 | 17.6 | 33.0 | -15.4 |
| | | | | 25 | 12 | 19.9 | 17.6 | 33.0 | -15.4 |
| | | | | 25 | 25 | 19.8 | 17.5 | 33.0 | -15.5 |
| | | | 50 | 0 | 19.9 | 17.6 | 33.0 | -15.4 | |
| | | | 16QAM | 1 | 0 | 19.8 | 17.5 | 33.0 | -15.5 |
| | | | | 1 | 25 | 19.7 | 17.4 | 33.0 | -15.6 |
| | | | | 1 | 49 | 19.7 | 17.4 | 33.0 | -15.6 |
| | | | | 25 | 0 | 19.5 | 17.2 | 33.0 | -15.8 |
| | | | | 25 | 12 | 19.4 | 17.1 | 33.0 | -15.9 |
| | | | | 25 | 25 | 19.4 | 17.1 | 33.0 | -15.9 |
| | | | 50 | 0 | 19.4 | 17.1 | 33.0 | -15.9 | |
| | | | 64QAM | 1 | 0 | 19.0 | 16.7 | 33.0 | -16.3 |
| | | | | 1 | 25 | 18.8 | 16.5 | 33.0 | -16.5 |
| | | | | 1 | 49 | 18.8 | 16.5 | 33.0 | -16.5 |
| | | | | 25 | 0 | 18.6 | 16.3 | 33.0 | -16.7 |
| | | | | 25 | 12 | 18.7 | 16.4 | 33.0 | -16.6 |
| | | | | 25 | 25 | 18.7 | 16.4 | 33.0 | -16.6 |
| | | | 50 | 0 | 18.7 | 16.4 | 33.0 | -16.6 | |

| Antenna gain (dBi) | | -2.30 | | | | | | | |
|--------------------|------------|-----------------|------------|---------|-----------|-------------------------|--------------------|------------------|-------------|
| Bandwidth | UL Channel | Frequency (MHz) | Modulation | RB Size | RB Offset | Conducted Average (dBm) | EIRP Average (dBm) | EIRP Limit (dBm) | Margin (dB) |
| 10.0 | 20350 | 1750.0 | QPSK | 1 | 0 | 19.8 | 17.5 | 33.0 | -15.5 |
| | | | | 1 | 25 | 19.8 | 17.5 | 33.0 | -15.5 |
| | | | | 1 | 49 | 19.8 | 17.5 | 33.0 | -15.5 |
| | | | | 25 | 0 | 19.9 | 17.6 | 33.0 | -15.4 |
| | | | | 25 | 12 | 19.8 | 17.5 | 33.0 | -15.5 |
| | | | | 25 | 25 | 19.8 | 17.5 | 33.0 | -15.5 |
| | | | | 50 | 0 | 19.9 | 17.6 | 33.0 | -15.5 |
| | | | 16QAM | 1 | 0 | 19.3 | 17.0 | 33.0 | -16.0 |
| | | | | 1 | 25 | 19.3 | 17.0 | 33.0 | -16.1 |
| | | | | 1 | 49 | 19.2 | 16.9 | 33.0 | -16.1 |
| | | | | 25 | 0 | 19.5 | 17.2 | 33.0 | -15.8 |
| | | | | 25 | 12 | 19.4 | 17.1 | 33.0 | -15.9 |
| | | | | 25 | 25 | 19.4 | 17.1 | 33.0 | -15.9 |
| | | | | 50 | 0 | 19.4 | 17.1 | 33.0 | -15.9 |
| | | | 64QAM | 1 | 0 | 18.8 | 16.5 | 33.0 | -16.5 |
| | | | | 1 | 25 | 18.8 | 16.5 | 33.0 | -16.5 |
| | | | | 1 | 49 | 18.9 | 16.6 | 33.0 | -16.4 |
| | | | | 25 | 0 | 18.8 | 16.5 | 33.0 | -16.5 |
| | | | | 25 | 12 | 18.7 | 16.4 | 33.0 | -16.6 |
| | | | | 25 | 25 | 18.7 | 16.4 | 33.0 | -16.6 |
| | | | | 50 | 0 | 18.7 | 16.4 | 33.0 | -16.6 |

| Antenna gain (dBi) | | -2.30 | | | | | | | |
|--------------------|------------|-----------------|------------|---------|-----------|-------------------------|--------------------|------------------|-------------|
| Bandwidth | UL Channel | Frequency (MHz) | Modulation | RB Size | RB Offset | Conducted Average (dBm) | EIRP Average (dBm) | EIRP Limit (dBm) | Margin (dB) |
| 15.0 | 20025 | 1717.5 | QPSK | 1 | 0 | 20.0 | 17.7 | 33.0 | -15.3 |
| | | | | 1 | 37 | 19.8 | 17.5 | 33.0 | -15.5 |
| | | | | 1 | 74 | 19.8 | 17.5 | 33.0 | -15.5 |
| | | | | 36 | 0 | 19.9 | 17.6 | 33.0 | -15.4 |
| | | | | 36 | 20 | 19.9 | 17.6 | 33.0 | -15.4 |
| | | | | 36 | 39 | 19.8 | 17.5 | 33.0 | -15.5 |
| | | | 75 | 0 | 19.8 | 17.5 | 33.0 | -15.5 | |
| | | | 16QAM | 1 | 0 | 20.0 | 17.7 | 33.0 | -15.3 |
| | | | | 1 | 37 | 19.7 | 17.4 | 33.0 | -15.6 |
| | | | | 1 | 74 | 19.7 | 17.4 | 33.0 | -15.7 |
| | | | | 36 | 0 | 19.4 | 17.1 | 33.0 | -15.9 |
| | | | | 36 | 20 | 19.4 | 17.1 | 33.0 | -16.0 |
| | | | | 36 | 39 | 19.3 | 17.0 | 33.0 | -16.0 |
| | | | 75 | 0 | 19.4 | 17.1 | 33.0 | -15.9 | |
| | | | 64QAM | 1 | 0 | 19.3 | 17.0 | 33.0 | -16.0 |
| | | | | 1 | 37 | 19.1 | 16.8 | 33.0 | -16.2 |
| | | | | 1 | 74 | 19.0 | 16.7 | 33.0 | -16.3 |
| | | | | 36 | 0 | 18.7 | 16.4 | 33.0 | -16.6 |
| | | | | 36 | 20 | 18.7 | 16.4 | 33.0 | -16.6 |
| | | | | 36 | 39 | 18.7 | 16.4 | 33.0 | -16.6 |
| | | | 75 | 0 | 18.7 | 16.4 | 33.0 | -16.6 | |
| 15.0 | 20175 | 1732.5 | QPSK | 1 | 0 | 20.0 | 17.7 | 33.0 | -15.3 |
| | | | | 1 | 37 | 19.8 | 17.5 | 33.0 | -15.5 |
| | | | | 1 | 74 | 19.9 | 17.6 | 33.0 | -15.4 |
| | | | | 36 | 0 | 19.9 | 17.6 | 33.0 | -15.4 |
| | | | | 36 | 20 | 19.9 | 17.6 | 33.0 | -15.4 |
| | | | | 36 | 39 | 19.9 | 17.6 | 33.0 | -15.5 |
| | | | 75 | 0 | 19.9 | 17.6 | 33.0 | -15.4 | |
| | | | 16QAM | 1 | 0 | 20.0 | 17.7 | 33.0 | -15.3 |
| | | | | 1 | 37 | 19.8 | 17.5 | 33.0 | -15.5 |
| | | | | 1 | 74 | 19.8 | 17.5 | 33.0 | -15.5 |
| | | | | 36 | 0 | 19.6 | 17.3 | 33.0 | -15.8 |
| | | | | 36 | 20 | 19.5 | 17.2 | 33.0 | -15.8 |
| | | | | 36 | 39 | 19.4 | 17.1 | 33.0 | -15.9 |
| | | | 75 | 0 | 19.4 | 17.1 | 33.0 | -15.9 | |
| | | | 64QAM | 1 | 0 | 19.2 | 16.9 | 33.0 | -16.1 |
| | | | | 1 | 37 | 19.0 | 16.7 | 33.0 | -16.3 |
| | | | | 1 | 74 | 19.0 | 16.7 | 33.0 | -16.3 |
| | | | | 36 | 0 | 18.8 | 16.5 | 33.0 | -16.5 |
| | | | | 36 | 20 | 18.7 | 16.4 | 33.0 | -16.6 |
| | | | | 36 | 39 | 18.7 | 16.4 | 33.0 | -16.6 |
| | | | 75 | 0 | 18.7 | 16.4 | 33.0 | -16.6 | |

| Antenna gain (dBi) | | -2.30 | | | | | | | |
|--------------------|------------|-----------------|------------|---------|-----------|-------------------------|--------------------|------------------|-------------|
| Bandwidth | UL Channel | Frequency (MHz) | Modulation | RB Size | RB Offset | Conducted Average (dBm) | EIRP Average (dBm) | EIRP Limit (dBm) | Margin (dB) |
| 15.0 | 20325 | 1747.5 | QPSK | 1 | 0 | 20.0 | 17.7 | 33.0 | -15.4 |
| | | | | 1 | 37 | 19.8 | 17.5 | 33.0 | -15.5 |
| | | | | 1 | 74 | 19.8 | 17.5 | 33.0 | -15.5 |
| | | | | 36 | 0 | 19.9 | 17.6 | 33.0 | -15.4 |
| | | | | 36 | 20 | 19.9 | 17.6 | 33.0 | -15.4 |
| | | | | 36 | 39 | 19.8 | 17.5 | 33.0 | -15.5 |
| | | | | 75 | 0 | 19.8 | 17.5 | 33.0 | -15.5 |
| | | | 16QAM | 1 | 0 | 19.4 | 17.1 | 33.0 | -16.0 |
| | | | | 1 | 37 | 19.3 | 17.0 | 33.0 | -16.0 |
| | | | | 1 | 74 | 19.3 | 17.0 | 33.0 | -16.0 |
| | | | | 36 | 0 | 19.4 | 17.1 | 33.0 | -15.9 |
| | | | | 36 | 20 | 19.4 | 17.1 | 33.0 | -15.9 |
| | | | | 36 | 39 | 19.4 | 17.1 | 33.0 | -15.9 |
| | | | | 75 | 0 | 19.3 | 17.0 | 33.0 | -16.0 |
| | | | 64QAM | 1 | 0 | 19.0 | 16.7 | 33.0 | -16.3 |
| | | | | 1 | 37 | 19.0 | 16.7 | 33.0 | -16.3 |
| | | | | 1 | 74 | 19.1 | 16.8 | 33.0 | -16.2 |
| | | | | 36 | 0 | 18.8 | 16.5 | 33.0 | -16.5 |
| | | | | 36 | 20 | 18.7 | 16.4 | 33.0 | -16.6 |
| | | | | 36 | 39 | 18.8 | 16.5 | 33.0 | -16.5 |
| | | | | 75 | 0 | 18.7 | 16.4 | 33.0 | -16.6 |

| Antenna gain (dBi) | | -2.30 | | | | | | | |
|--------------------|------------|-----------------|------------|---------|-----------|-------------------------|--------------------|------------------|-------------|
| Bandwidth | UL Channel | Frequency (MHz) | Modulation | RB Size | RB Offset | Conducted Average (dBm) | EIRP Average (dBm) | EIRP Limit (dBm) | Margin (dB) |
| 20.0 | 20175 | 1732.5 | QPSK | 1 | 0 | 20.0 | 17.7 | 33.0 | -15.3 |
| | | | | 1 | 12 | 19.8 | 17.5 | 33.0 | -15.5 |
| | | | | 1 | 24 | 19.9 | 17.6 | 33.0 | -15.5 |
| | | | | 12 | 0 | 20.0 | 17.7 | 33.0 | -15.3 |
| | | | | 12 | 7 | 19.9 | 17.6 | 33.0 | -15.4 |
| | | | | 12 | 13 | 19.8 | 17.5 | 33.0 | -15.5 |
| | | | | 25 | 0 | 19.9 | 17.6 | 33.0 | -15.4 |
| | | | 16QAM | 1 | 0 | 20.0 | 17.7 | 33.0 | -15.3 |
| | | | | 1 | 12 | 19.8 | 17.5 | 33.0 | -15.5 |
| | | | | 1 | 24 | 19.8 | 17.5 | 33.0 | -15.5 |
| | | | | 12 | 0 | 19.5 | 17.2 | 33.0 | -15.8 |
| | | | | 12 | 7 | 19.4 | 17.1 | 33.0 | -15.9 |
| | | | | 12 | 13 | 19.4 | 17.1 | 33.0 | -15.9 |
| | | | | 25 | 0 | 19.4 | 17.1 | 33.0 | -15.9 |
| | | | 64QAM | 1 | 0 | 19.2 | 16.9 | 33.0 | -16.1 |
| | | | | 1 | 12 | 19.0 | 16.7 | 33.0 | -16.3 |
| | | | | 1 | 24 | 18.9 | 16.6 | 33.0 | -16.4 |
| | | | | 12 | 0 | 18.8 | 16.5 | 33.0 | -16.5 |
| | | | | 12 | 7 | 18.8 | 16.5 | 33.0 | -16.5 |
| | | | | 12 | 13 | 18.7 | 16.4 | 33.0 | -16.6 |
| | | | | 25 | 0 | 18.7 | 16.4 | 33.0 | -16.6 |

LTE Band 12

| Antenna gain (dBi) | | -7.90 | | | | | | | | | | |
|--------------------|------------|-----------------|------------|---------|-----------|-------------------------|-------------------|-----------------|-------------|------|------|-------|
| Bandwidth | UL Channel | Frequency (MHz) | Modulation | RB Size | RB Offset | Conducted Average (dBm) | ERP Average (dBm) | ERP Limit (dBm) | Margin (dB) | | | |
| 1.4 | 23017 | 699.7 | QPSK | 1 | 0 | 24.9 | 14.5 | 34.7 | -20.2 | | | |
| | | | | 1 | 3 | 25.0 | 14.6 | 34.7 | -20.1 | | | |
| | | | | 1 | 5 | 24.9 | 14.5 | 34.7 | -20.2 | | | |
| | | | | 3 | 0 | 24.9 | 14.5 | 34.7 | -20.2 | | | |
| | | | | 3 | 1 | 25.0 | 14.6 | 34.7 | -20.1 | | | |
| | | | | 3 | 3 | 25.0 | 14.6 | 34.7 | -20.1 | | | |
| | | | 16QAM | 6 | 0 | 23.9 | 13.5 | 34.7 | -21.2 | | | |
| | | | | 1 | 0 | 24.0 | 13.6 | 34.7 | -21.1 | | | |
| | | | | 1 | 3 | 24.0 | 13.6 | 34.7 | -21.1 | | | |
| | | | | 1 | 5 | 24.0 | 13.6 | 34.7 | -21.1 | | | |
| | | | | 3 | 0 | 24.0 | 13.6 | 34.7 | -21.1 | | | |
| | | | | 3 | 1 | 24.0 | 13.6 | 34.7 | -21.1 | | | |
| | | | 64QAM | 3 | 3 | 24.0 | 13.6 | 34.7 | -21.1 | | | |
| | | | | 6 | 0 | 23.0 | 12.6 | 34.7 | -22.1 | | | |
| | | | | 1 | 0 | 22.9 | 12.5 | 34.7 | -22.2 | | | |
| | | | | 1 | 3 | 23.0 | 12.6 | 34.7 | -22.1 | | | |
| | | | | 1 | 5 | 22.9 | 12.5 | 34.7 | -22.2 | | | |
| | | | | 3 | 0 | 22.8 | 12.4 | 34.7 | -22.3 | | | |
| | | | 1.4 | 23095 | 707.5 | QPSK | 3 | 1 | 22.8 | 12.4 | 34.7 | -22.3 |
| | | | | | | | 3 | 3 | 22.9 | 12.5 | 34.7 | -22.2 |
| | | | | | | | 6 | 0 | 21.8 | 11.4 | 34.7 | -23.3 |
| | | | | | | | 1 | 0 | 24.9 | 14.5 | 34.7 | -20.2 |
| | | | | | | | 1 | 3 | 25.0 | 14.6 | 34.7 | -20.1 |
| | | | | | | | 1 | 5 | 24.9 | 14.5 | 34.7 | -20.2 |
| 16QAM | 3 | 0 | | | | 24.9 | 14.5 | 34.7 | -20.2 | | | |
| | 3 | 1 | | | | 25.0 | 14.6 | 34.7 | -20.1 | | | |
| | 3 | 3 | | | | 25.0 | 14.6 | 34.7 | -20.1 | | | |
| | 6 | 0 | | | | 23.9 | 13.5 | 34.7 | -21.2 | | | |
| | 1 | 0 | | | | 23.6 | 13.2 | 34.7 | -21.5 | | | |
| | 1 | 3 | | | | 23.7 | 13.3 | 34.7 | -21.4 | | | |
| 64QAM | 1 | 5 | | | | 23.7 | 13.3 | 34.7 | -21.4 | | | |
| | 3 | 0 | | | | 24.0 | 13.6 | 34.7 | -21.1 | | | |
| | 3 | 1 | | | | 24.0 | 13.6 | 34.7 | -21.1 | | | |
| | 3 | 3 | | | | 24.0 | 13.6 | 34.7 | -21.1 | | | |
| | 6 | 0 | | | | 22.8 | 12.4 | 34.7 | -22.3 | | | |
| | 1 | 0 | | | | 22.5 | 12.1 | 34.7 | -22.6 | | | |
| QPSK | 1 | 3 | | | | 23.0 | 12.6 | 34.7 | -22.1 | | | |
| | 1 | 5 | | | | 22.6 | 12.2 | 34.7 | -22.5 | | | |
| | 3 | 0 | | | | 22.7 | 12.3 | 34.7 | -22.4 | | | |
| | 3 | 1 | | | | 23.0 | 12.6 | 34.7 | -22.1 | | | |
| | 3 | 3 | | | | 23.0 | 12.6 | 34.7 | -22.1 | | | |
| | 6 | 0 | | | | 21.7 | 11.3 | 34.7 | -23.4 | | | |

| Antenna gain (dBi) | | -7.90 | | | | | | | |
|--------------------|------------|-----------------|------------|---------|-----------|-------------------------|-------------------|-----------------|-------------|
| Bandwidth | UL Channel | Frequency (MHz) | Modulation | RB Size | RB Offset | Conducted Average (dBm) | ERP Average (dBm) | ERP Limit (dBm) | Margin (dB) |
| 1.4 | 23173 | 715.3 | QPSK | 1 | 0 | 23.8 | 13.4 | 34.7 | -21.3 |
| | | | | 1 | 3 | 24.9 | 14.5 | 34.7 | -20.2 |
| | | | | 1 | 5 | 24.7 | 14.3 | 34.7 | -20.4 |
| | | | | 3 | 0 | 24.8 | 14.4 | 34.7 | -20.3 |
| | | | | 3 | 1 | 24.8 | 14.4 | 34.7 | -20.3 |
| | | | | 3 | 3 | 24.8 | 14.4 | 34.7 | -20.3 |
| | | | 16QAM | 6 | 0 | 23.8 | 13.4 | 34.7 | -21.3 |
| | | | | 1 | 0 | 23.9 | 13.5 | 34.7 | -21.2 |
| | | | | 1 | 3 | 23.9 | 13.5 | 34.7 | -21.2 |
| | | | | 1 | 5 | 23.8 | 13.4 | 34.7 | -21.3 |
| | | | | 3 | 0 | 23.9 | 13.5 | 34.7 | -21.2 |
| | | | | 3 | 1 | 24.0 | 13.6 | 34.7 | -21.1 |
| | | | 64QAM | 3 | 3 | 24.0 | 13.6 | 34.7 | -21.1 |
| | | | | 6 | 0 | 22.9 | 12.5 | 34.7 | -22.2 |
| | | | | 1 | 0 | 22.7 | 12.3 | 34.7 | -22.4 |
| | | | | 1 | 3 | 23.0 | 12.6 | 34.7 | -22.1 |
| | | | | 1 | 5 | 22.8 | 12.4 | 34.7 | -22.3 |
| | | | | 3 | 0 | 22.7 | 12.3 | 34.7 | -22.4 |
| | | | 64QAM | 3 | 1 | 22.7 | 12.3 | 34.7 | -22.4 |
| | | | | 3 | 3 | 22.6 | 12.2 | 34.7 | -22.5 |
| | | | | 6 | 0 | 21.5 | 11.1 | 34.7 | -23.6 |

| Antenna gain (dBi) | | -7.90 | | | | | | | | | | |
|--------------------|------------|-----------------|------------|---------|-----------|-------------------------|-------------------|-----------------|-------------|------|------|-------|
| Bandwidth | UL Channel | Frequency (MHz) | Modulation | RB Size | RB Offset | Conducted Average (dBm) | ERP Average (dBm) | ERP Limit (dBm) | Margin (dB) | | | |
| 3.0 | 23025 | 700.5 | QPSK | 1 | 0 | 24.3 | 13.9 | 34.7 | -20.8 | | | |
| | | | | 1 | 8 | 24.3 | 13.9 | 34.7 | -20.8 | | | |
| | | | | 1 | 14 | 24.2 | 13.8 | 34.7 | -20.9 | | | |
| | | | | 8 | 0 | 24.0 | 13.6 | 34.7 | -21.1 | | | |
| | | | | 8 | 4 | 24.0 | 13.6 | 34.7 | -21.1 | | | |
| | | | | 8 | 7 | 24.0 | 13.6 | 34.7 | -21.1 | | | |
| | | | 16QAM | 15 | 0 | 24.0 | 13.6 | 34.7 | -21.1 | | | |
| | | | | 1 | 0 | 24.0 | 13.6 | 34.7 | -21.1 | | | |
| | | | | 1 | 8 | 24.0 | 13.6 | 34.7 | -21.1 | | | |
| | | | | 1 | 14 | 24.0 | 13.6 | 34.7 | -21.1 | | | |
| | | | | 8 | 0 | 23.0 | 12.6 | 34.7 | -22.1 | | | |
| | | | | 8 | 4 | 23.0 | 12.6 | 34.7 | -22.1 | | | |
| | | | 64QAM | 8 | 7 | 23.0 | 12.6 | 34.7 | -22.1 | | | |
| | | | | 15 | 0 | 22.9 | 12.5 | 34.7 | -22.2 | | | |
| | | | | 1 | 0 | 23.0 | 12.6 | 34.7 | -22.1 | | | |
| | | | | 1 | 8 | 23.0 | 12.6 | 34.7 | -22.1 | | | |
| | | | | 1 | 14 | 22.8 | 12.4 | 34.7 | -22.3 | | | |
| | | | | 8 | 0 | 21.8 | 11.4 | 34.7 | -23.3 | | | |
| | | | 3.0 | 23095 | 707.5 | QPSK | 8 | 4 | 21.7 | 11.3 | 34.7 | -23.4 |
| | | | | | | | 15 | 0 | 21.7 | 11.3 | 34.7 | -23.4 |
| | | | | | | | 1 | 0 | 24.2 | 13.8 | 34.7 | -20.9 |
| 1 | 8 | 24.4 | | | | | 14.0 | 34.7 | -20.7 | | | |
| 1 | 14 | 24.2 | | | | | 13.8 | 34.7 | -20.9 | | | |
| 8 | 0 | 24.0 | | | | | 13.6 | 34.7 | -21.1 | | | |
| 16QAM | 8 | 4 | | | | 24.0 | 13.6 | 34.7 | -21.1 | | | |
| | 8 | 7 | | | | 24.0 | 13.6 | 34.7 | -21.1 | | | |
| | 15 | 0 | | | | 24.0 | 13.6 | 34.7 | -21.1 | | | |
| | 1 | 0 | | | | 23.7 | 13.3 | 34.7 | -21.4 | | | |
| | 1 | 8 | | | | 23.8 | 13.4 | 34.7 | -21.3 | | | |
| | 1 | 14 | | | | 23.8 | 13.4 | 34.7 | -21.3 | | | |
| 64QAM | 8 | 0 | | | | 23.0 | 12.6 | 34.7 | -22.1 | | | |
| | 8 | 4 | | | | 23.0 | 12.6 | 34.7 | -22.1 | | | |
| | 8 | 7 | | | | 23.0 | 12.6 | 34.7 | -22.1 | | | |
| | 15 | 0 | | | | 23.0 | 12.6 | 34.7 | -22.1 | | | |
| | 1 | 0 | | | | 22.6 | 12.2 | 34.7 | -22.5 | | | |
| | 1 | 8 | | | | 23.0 | 12.6 | 34.7 | -22.1 | | | |
| 64QAM | 1 | 14 | | | | 22.8 | 12.4 | 34.7 | -22.3 | | | |
| | 8 | 0 | | | | 21.7 | 11.3 | 34.7 | -23.4 | | | |
| | 8 | 4 | | | | 21.8 | 11.4 | 34.7 | -23.3 | | | |
| | 8 | 7 | 21.8 | 11.4 | 34.7 | -23.3 | | | | | | |
| | 15 | 0 | 21.7 | 11.3 | 34.7 | -23.4 | | | | | | |

| Antenna gain (dBi) | | -9.00 | | | | | | | |
|--------------------|------------|-----------------|------------|---------|-----------|-------------------------|-------------------|-----------------|-------------|
| Bandwidth | UL Channel | Frequency (MHz) | Modulation | RB Size | RB Offset | Conducted Average (dBm) | ERP Average (dBm) | ERP Limit (dBm) | Margin (dB) |
| 3.0 | 23165 | 714.5 | QPSK | 1 | 0 | 24.2 | 12.7 | 34.7 | -22.0 |
| | | | | 1 | 8 | 24.2 | 12.7 | 34.7 | -22.0 |
| | | | | 1 | 14 | 24.1 | 12.6 | 34.7 | -22.1 |
| | | | | 8 | 0 | 23.9 | 12.4 | 34.7 | -22.3 |
| | | | | 8 | 4 | 23.9 | 12.4 | 34.7 | -22.3 |
| | | | | 8 | 7 | 23.9 | 12.4 | 34.7 | -22.3 |
| | | | | 15 | 0 | 23.9 | 12.4 | 34.7 | -22.3 |
| | | | 16QAM | 1 | 0 | 23.8 | 12.3 | 34.7 | -22.4 |
| | | | | 1 | 8 | 23.8 | 12.3 | 34.7 | -22.4 |
| | | | | 1 | 14 | 23.7 | 12.2 | 34.7 | -22.5 |
| | | | | 8 | 0 | 23.0 | 11.5 | 34.7 | -23.2 |
| | | | | 8 | 4 | 23.0 | 11.5 | 34.7 | -23.2 |
| | | | | 8 | 7 | 23.0 | 11.5 | 34.7 | -23.2 |
| | | | | 15 | 0 | 22.9 | 11.4 | 34.7 | -23.3 |
| | | | 64QAM | 1 | 0 | 22.6 | 11.1 | 34.7 | -23.6 |
| | | | | 1 | 8 | 22.6 | 11.1 | 34.7 | -23.6 |
| | | | | 1 | 14 | 22.7 | 11.2 | 34.7 | -23.5 |
| | | | | 8 | 0 | 21.8 | 10.3 | 34.7 | -24.4 |
| | | | | 8 | 4 | 21.6 | 10.1 | 34.7 | -24.6 |
| | | | | 8 | 7 | 21.6 | 10.1 | 34.7 | -24.6 |
| | | | | 15 | 0 | 21.5 | 10.0 | 34.7 | -24.7 |

| Antenna gain (dBi) | | -7.90 | | | | | | | | | | |
|--------------------|------------|-----------------|------------|---------|-----------|-------------------------|-------------------|-----------------|-------------|------|------|-------|
| Bandwidth | UL Channel | Frequency (MHz) | Modulation | RB Size | RB Offset | Conducted Average (dBm) | ERP Average (dBm) | ERP Limit (dBm) | Margin (dB) | | | |
| 5.0 | 23035 | 701.5 | QPSK | 1 | 0 | 24.3 | 13.9 | 34.7 | -20.8 | | | |
| | | | | 1 | 12 | 24.3 | 13.9 | 34.7 | -20.8 | | | |
| | | | | 1 | 24 | 24.2 | 13.8 | 34.7 | -20.9 | | | |
| | | | | 12 | 0 | 24.0 | 13.6 | 34.7 | -21.1 | | | |
| | | | | 12 | 7 | 24.0 | 13.6 | 34.7 | -21.1 | | | |
| | | | | 12 | 13 | 24.0 | 13.6 | 34.7 | -21.1 | | | |
| | | | 16QAM | 25 | 0 | 24.0 | 13.6 | 34.7 | -21.1 | | | |
| | | | | 1 | 0 | 23.8 | 13.4 | 34.7 | -21.3 | | | |
| | | | | 1 | 12 | 23.9 | 13.5 | 34.7 | -21.2 | | | |
| | | | | 1 | 24 | 23.8 | 13.4 | 34.7 | -21.3 | | | |
| | | | | 12 | 0 | 23.0 | 12.6 | 34.7 | -22.1 | | | |
| | | | | 12 | 7 | 23.0 | 12.6 | 34.7 | -22.1 | | | |
| | | | 64QAM | 12 | 13 | 23.0 | 12.6 | 34.7 | -22.1 | | | |
| | | | | 25 | 0 | 23.0 | 12.6 | 34.7 | -22.1 | | | |
| | | | | 1 | 0 | 23.0 | 12.6 | 34.7 | -22.1 | | | |
| | | | | 1 | 12 | 23.0 | 12.6 | 34.7 | -22.1 | | | |
| | | | | 1 | 24 | 23.0 | 12.6 | 34.7 | -22.1 | | | |
| | | | | 12 | 0 | 22.0 | 11.6 | 34.7 | -23.1 | | | |
| | | | 5.0 | 23095 | 707.5 | QPSK | 12 | 7 | 21.6 | 11.2 | 34.7 | -23.5 |
| | | | | | | | 12 | 13 | 21.7 | 11.3 | 34.7 | -23.4 |
| | | | | | | | 25 | 0 | 21.6 | 11.2 | 34.7 | -23.5 |
| 1 | 0 | 24.3 | | | | | 13.9 | 34.7 | -20.8 | | | |
| 1 | 12 | 24.3 | | | | | 13.9 | 34.7 | -20.8 | | | |
| 1 | 24 | 24.2 | | | | | 13.8 | 34.7 | -20.9 | | | |
| 16QAM | 12 | 0 | | | | 24.0 | 13.6 | 34.7 | -21.1 | | | |
| | 12 | 7 | | | | 24.0 | 13.6 | 34.7 | -21.1 | | | |
| | 12 | 13 | | | | 24.0 | 13.6 | 34.7 | -21.1 | | | |
| | 25 | 0 | | | | 24.0 | 13.6 | 34.7 | -21.1 | | | |
| | 1 | 0 | | | | 24.0 | 13.6 | 34.7 | -21.1 | | | |
| | 1 | 2 | | | | 24.0 | 13.6 | 34.7 | -21.1 | | | |
| 64QAM | 1 | 5 | | | | 24.0 | 13.6 | 34.7 | -21.1 | | | |
| | 3 | 0 | | | | 23.0 | 12.6 | 34.7 | -22.1 | | | |
| | 3 | 1 | | | | 23.0 | 12.6 | 34.7 | -22.1 | | | |
| | 3 | 2 | 23.0 | 12.6 | 34.7 | -22.1 | | | | | | |
| | 6 | 0 | 23.0 | 12.6 | 34.7 | -22.1 | | | | | | |
| | 1 | 0 | 22.4 | 12.0 | 34.7 | -22.7 | | | | | | |
| 64QAM | 1 | 12 | 22.6 | 12.2 | 34.7 | -22.5 | | | | | | |
| | 1 | 24 | 22.4 | 12.0 | 34.7 | -22.7 | | | | | | |
| | 12 | 0 | 21.7 | 11.3 | 34.7 | -23.4 | | | | | | |
| | 12 | 7 | 21.7 | 11.3 | 34.7 | -23.4 | | | | | | |
| | 12 | 13 | 21.6 | 11.2 | 34.7 | -23.5 | | | | | | |
| | 25 | 0 | 21.6 | 11.2 | 34.7 | -23.5 | | | | | | |

| Antenna gain (dBi) | | -7.90 | | | | | | | | | | |
|--------------------|------------|-----------------|------------|---------|-----------|-------------------------|-------------------|-----------------|-------------|------|------|-------|
| Bandwidth | UL Channel | Frequency (MHz) | Modulation | RB Size | RB Offset | Conducted Average (dBm) | ERP Average (dBm) | ERP Limit (dBm) | Margin (dB) | | | |
| 5.0 | 23155 | 713.5 | QPSK | 1 | 0 | 24.3 | 13.9 | 34.7 | -20.8 | | | |
| | | | | 1 | 12 | 24.2 | 13.8 | 34.7 | -20.9 | | | |
| | | | | 1 | 24 | 24.2 | 13.8 | 34.7 | -20.9 | | | |
| | | | | 12 | 0 | 23.9 | 13.5 | 34.7 | -21.2 | | | |
| | | | | 12 | 7 | 23.9 | 13.5 | 34.7 | -21.2 | | | |
| | | | | 12 | 13 | 23.9 | 13.5 | 34.7 | -21.2 | | | |
| | | | 16QAM | 1 | 0 | 24.0 | 13.6 | 34.7 | -21.1 | | | |
| | | | | 1 | 12 | 24.0 | 13.6 | 34.7 | -21.1 | | | |
| | | | | 1 | 24 | 24.0 | 13.6 | 34.7 | -21.1 | | | |
| | | | | 12 | 0 | 23.0 | 12.6 | 34.7 | -22.1 | | | |
| | | | | 12 | 7 | 23.0 | 12.6 | 34.7 | -22.1 | | | |
| | | | | 12 | 13 | 22.9 | 12.5 | 34.7 | -22.2 | | | |
| | | | 64QAM | 1 | 0 | 22.9 | 12.5 | 34.7 | -22.2 | | | |
| | | | | 1 | 12 | 23.0 | 12.6 | 34.7 | -22.1 | | | |
| | | | | 1 | 24 | 23.0 | 12.6 | 34.7 | -22.1 | | | |
| | | | | 12 | 0 | 21.6 | 11.2 | 34.7 | -23.5 | | | |
| | | | | 12 | 7 | 21.6 | 11.2 | 34.7 | -23.5 | | | |
| | | | | 12 | 13 | 21.6 | 11.2 | 34.7 | -23.5 | | | |
| | | | | | | | 25 | 0 | 21.6 | 11.2 | 34.7 | -23.5 |

| Antenna gain (dBi) | | -7.90 | | | | | | | |
|--------------------|------------|-----------------|------------|---------|-----------|-------------------------|-------------------|-----------------|-------------|
| Bandwidth | UL Channel | Frequency (MHz) | Modulation | RB Size | RB Offset | Conducted Average (dBm) | ERP Average (dBm) | ERP Limit (dBm) | Margin (dB) |
| 10.0 | 23095 | 707.5 | QPSK | 1 | 0 | 24.3 | 13.9 | 34.7 | -20.8 |
| | | | | 1 | 25 | 24.3 | 13.9 | 34.7 | -20.8 |
| | | | | 1 | 49 | 24.2 | 13.8 | 34.7 | -20.9 |
| | | | | 25 | 0 | 23.9 | 13.5 | 34.7 | -21.2 |
| | | | | 25 | 12 | 24.0 | 13.6 | 34.7 | -21.1 |
| | | | | 25 | 25 | 23.8 | 13.4 | 34.7 | -21.3 |
| | | | 16QAM | 50 | 0 | 23.9 | 13.5 | 34.7 | -21.2 |
| | | | | 1 | 0 | 23.7 | 13.3 | 34.7 | -21.4 |
| | | | | 1 | 25 | 23.8 | 13.4 | 34.7 | -21.3 |
| | | | | 1 | 49 | 23.6 | 13.2 | 34.7 | -21.5 |
| | | | | 25 | 0 | 23.0 | 12.6 | 34.7 | -22.1 |
| | | | | 25 | 12 | 23.0 | 12.6 | 34.7 | -22.1 |
| | | | 64QAM | 25 | 25 | 22.9 | 12.5 | 34.7 | -22.2 |
| | | | | 50 | 0 | 22.9 | 12.5 | 34.7 | -22.2 |
| | | | | 1 | 0 | 22.8 | 12.4 | 34.7 | -22.3 |
| | | | | 1 | 25 | 22.9 | 12.5 | 34.7 | -22.2 |
| | | | | 1 | 49 | 22.8 | 12.4 | 34.7 | -22.3 |
| | | | | 25 | 0 | 21.5 | 11.1 | 34.7 | -23.6 |
| | | | | 25 | 12 | 21.7 | 11.3 | 34.7 | -23.4 |
| | | | | 25 | 25 | 21.5 | 11.1 | 34.7 | -23.6 |
| | | | | 50 | 0 | 21.6 | 11.2 | 34.7 | -23.5 |

LTE Band 41

| Antenna gain (dBi) | | -3.80 | | | | | | | |
|--------------------|------------|-----------------|------------|---------|-----------|-------------------------|--------------------|------------------|-------------|
| Bandwidth | UL Channel | Frequency (MHz) | Modulation | RB Size | RB Offset | Conducted Average (dBm) | EIRP Average (dBm) | EIRP Limit (dBm) | Margin (dB) |
| 5.0 | 39675 | 2498.5 | QPSK | 1 | 0 | 23.8 | 20.0 | 33.0 | -13.0 |
| | | | | 1 | 12 | 23.7 | 19.9 | 33.0 | -13.1 |
| | | | | 1 | 24 | 23.7 | 19.9 | 33.0 | -13.1 |
| | | | | 12 | 0 | 23.8 | 20.0 | 33.0 | -13.0 |
| | | | | 12 | 7 | 23.8 | 20.0 | 33.0 | -13.0 |
| | | | | 12 | 13 | 23.7 | 19.9 | 33.0 | -13.1 |
| | | | | 25 | 0 | 23.8 | 20.0 | 33.0 | -13.0 |
| | | | 16QAM | 1 | 0 | 23.2 | 19.4 | 33.0 | -13.6 |
| | | | | 1 | 12 | 23.2 | 19.4 | 33.0 | -13.6 |
| | | | | 1 | 24 | 23.1 | 19.3 | 33.0 | -13.7 |
| | | | | 12 | 0 | 22.2 | 18.4 | 33.0 | -14.6 |
| | | | | 12 | 7 | 22.3 | 18.5 | 33.0 | -14.6 |
| | | | | 12 | 13 | 22.2 | 18.4 | 33.0 | -14.6 |
| | | | | 25 | 0 | 22.3 | 18.5 | 33.0 | -14.6 |
| | | | 64QAM | 1 | 0 | 21.7 | 17.9 | 33.0 | -15.1 |
| | | | | 1 | 12 | 21.8 | 18.0 | 33.0 | -15.0 |
| | | | | 1 | 24 | 21.7 | 17.9 | 33.0 | -15.1 |
| | | | | 12 | 0 | 20.7 | 16.9 | 33.0 | -16.1 |
| | | | | 12 | 7 | 20.7 | 16.9 | 33.0 | -16.1 |
| | | | | 12 | 13 | 20.7 | 16.9 | 33.0 | -16.1 |
| | | | | 25 | 0 | 20.7 | 16.9 | 33.0 | -16.1 |
| 5.0 | 40620 | 2593.0 | QPSK | 1 | 0 | 23.9 | 20.1 | 33.0 | -13.0 |
| | | | | 1 | 12 | 23.8 | 20.0 | 33.0 | -13.0 |
| | | | | 1 | 24 | 23.7 | 19.9 | 33.0 | -13.1 |
| | | | | 12 | 0 | 23.8 | 20.0 | 33.0 | -13.0 |
| | | | | 12 | 7 | 23.9 | 20.1 | 33.0 | -12.9 |
| | | | | 12 | 13 | 23.8 | 20.0 | 33.0 | -13.0 |
| | | | | 25 | 0 | 23.8 | 20.0 | 33.0 | -13.0 |
| | | | 16QAM | 1 | 0 | 23.4 | 19.6 | 33.0 | -13.4 |
| | | | | 1 | 12 | 23.4 | 19.6 | 33.0 | -13.4 |
| | | | | 1 | 24 | 23.3 | 19.5 | 33.0 | -13.5 |
| | | | | 12 | 0 | 22.4 | 18.6 | 33.0 | -14.4 |
| | | | | 12 | 7 | 22.4 | 18.6 | 33.0 | -14.4 |
| | | | | 12 | 13 | 22.4 | 18.6 | 33.0 | -14.5 |
| | | | | 25 | 0 | 22.3 | 18.5 | 33.0 | -14.5 |
| | | | 64QAM | 1 | 0 | 22.3 | 18.5 | 33.0 | -14.5 |
| | | | | 1 | 12 | 22.0 | 18.2 | 33.0 | -14.8 |
| | | | | 1 | 24 | 21.9 | 18.1 | 33.0 | -14.9 |
| | | | | 12 | 0 | 20.9 | 17.1 | 33.0 | -15.9 |
| | | | | 12 | 7 | 20.9 | 17.1 | 33.0 | -15.9 |
| | | | | 12 | 13 | 20.8 | 17.0 | 33.0 | -16.0 |
| | | | | 25 | 0 | 20.9 | 17.1 | 33.0 | -15.9 |

| Antenna gain (dBi) | | -3.80 | | | | | | | |
|--------------------|------------|-----------------|------------|---------|-----------|-------------------------|--------------------|------------------|-------------|
| Bandwidth | UL Channel | Frequency (MHz) | Modulation | RB Size | RB Offset | Conducted Average (dBm) | EIRP Average (dBm) | EIRP Limit (dBm) | Margin (dB) |
| 5.0 | 41565 | 2687.5 | QPSK | 1 | 0 | 23.4 | 19.6 | 33.0 | -13.4 |
| | | | | 1 | 12 | 23.4 | 19.6 | 33.0 | -13.4 |
| | | | | 1 | 24 | 23.3 | 19.5 | 33.0 | -13.5 |
| | | | | 12 | 0 | 23.3 | 19.5 | 33.0 | -13.5 |
| | | | | 12 | 7 | 23.3 | 19.5 | 33.0 | -13.5 |
| | | | | 12 | 13 | 23.3 | 19.5 | 33.0 | -13.5 |
| | | | | 25 | 0 | 23.2 | 19.4 | 33.0 | -13.6 |
| | | | 16QAM | 1 | 0 | 23.3 | 19.5 | 33.0 | -13.5 |
| | | | | 1 | 12 | 23.3 | 19.5 | 33.0 | -13.5 |
| | | | | 1 | 24 | 23.2 | 19.4 | 33.0 | -13.6 |
| | | | | 12 | 0 | 22.4 | 18.6 | 33.0 | -14.5 |
| | | | | 12 | 7 | 22.3 | 18.5 | 33.0 | -14.5 |
| | | | | 12 | 13 | 22.3 | 18.5 | 33.0 | -14.5 |
| | | | | 25 | 0 | 22.3 | 18.5 | 33.0 | -14.5 |
| | | | 64QAM | 1 | 0 | 21.6 | 17.8 | 33.0 | -15.2 |
| | | | | 1 | 12 | 21.6 | 17.8 | 33.0 | -15.2 |
| | | | | 1 | 24 | 21.7 | 17.9 | 33.0 | -15.1 |
| | | | | 12 | 0 | 20.6 | 16.8 | 33.0 | -16.2 |
| | | | | 12 | 7 | 20.6 | 16.8 | 33.0 | -16.2 |
| | | | | 12 | 13 | 20.5 | 16.7 | 33.0 | -16.3 |
| | | | | 25 | 0 | 20.0 | 16.2 | 33.0 | -16.8 |

| Antenna gain (dBi) | | -3.80 | | | | | | | | | | |
|--------------------|------------|-----------------|------------|---------|-----------|-------------------------|--------------------|------------------|-------------|------|------|-------|
| Bandwidth | UL Channel | Frequency (MHz) | Modulation | RB Size | RB Offset | Conducted Average (dBm) | EIRP Average (dBm) | EIRP Limit (dBm) | Margin (dB) | | | |
| 10.0 | 39700 | 2501.0 | QPSK | 1 | 0 | 23.7 | 19.9 | 33.0 | -13.2 | | | |
| | | | | 1 | 25 | 23.6 | 19.8 | 33.0 | -13.3 | | | |
| | | | | 1 | 49 | 23.5 | 19.7 | 33.0 | -13.3 | | | |
| | | | | 25 | 0 | 23.7 | 19.9 | 33.0 | -13.1 | | | |
| | | | | 25 | 12 | 23.7 | 19.9 | 33.0 | -13.1 | | | |
| | | | | 25 | 25 | 23.6 | 19.8 | 33.0 | -13.2 | | | |
| | | | 16QAM | 1 | 0 | 23.2 | 19.4 | 33.0 | -13.7 | | | |
| | | | | 1 | 25 | 23.1 | 19.3 | 33.0 | -13.8 | | | |
| | | | | 1 | 49 | 23.0 | 19.2 | 33.0 | -13.8 | | | |
| | | | | 25 | 0 | 22.2 | 18.4 | 33.0 | -14.6 | | | |
| | | | | 25 | 12 | 22.2 | 18.4 | 33.0 | -14.6 | | | |
| | | | | 25 | 25 | 22.1 | 18.3 | 33.0 | -14.7 | | | |
| | | | 64QAM | 1 | 0 | 21.7 | 17.9 | 33.0 | -15.1 | | | |
| | | | | 1 | 25 | 21.8 | 18.0 | 33.0 | -15.0 | | | |
| | | | | 1 | 49 | 21.7 | 17.9 | 33.0 | -15.1 | | | |
| | | | | 25 | 0 | 20.7 | 16.9 | 33.0 | -16.1 | | | |
| | | | | 25 | 12 | 20.7 | 16.9 | 33.0 | -16.1 | | | |
| | | | | 25 | 25 | 20.7 | 16.9 | 33.0 | -16.1 | | | |
| | | | 10.0 | 40620 | 2593.0 | QPSK | 1 | 0 | 23.8 | 20.0 | 33.0 | -13.0 |
| | | | | | | | 1 | 25 | 23.7 | 19.9 | 33.0 | -13.1 |
| | | | | | | | 1 | 49 | 23.7 | 19.9 | 33.0 | -13.1 |
| 25 | 0 | 23.9 | | | | | 20.1 | 33.0 | -12.9 | | | |
| 25 | 12 | 23.8 | | | | | 20.0 | 33.0 | -13.0 | | | |
| 25 | 25 | 23.8 | | | | | 20.0 | 33.0 | -13.1 | | | |
| 16QAM | 50 | 0 | | | | 23.7 | 19.9 | 33.0 | -13.1 | | | |
| | 1 | 0 | | | | 23.4 | 19.6 | 33.0 | -13.4 | | | |
| | 1 | 25 | | | | 23.4 | 19.6 | 33.0 | -13.4 | | | |
| | 1 | 49 | | | | 23.3 | 19.5 | 33.0 | -13.5 | | | |
| | 25 | 0 | | | | 22.4 | 18.6 | 33.0 | -14.4 | | | |
| | 25 | 12 | | | | 22.3 | 18.5 | 33.0 | -14.5 | | | |
| 64QAM | 25 | 25 | | | | 22.3 | 18.5 | 33.0 | -14.5 | | | |
| | 50 | 0 | | | | 22.3 | 18.5 | 33.0 | -14.5 | | | |
| | 1 | 0 | | | | 22.3 | 18.5 | 33.0 | -14.5 | | | |
| | 1 | 25 | | | | 22.0 | 18.2 | 33.0 | -14.8 | | | |
| | 1 | 49 | | | | 21.9 | 18.1 | 33.0 | -14.9 | | | |
| | 25 | 0 | | | | 20.9 | 17.1 | 33.0 | -15.9 | | | |
| | | | | | | | 25 | 12 | 20.9 | 17.1 | 33.0 | -15.9 |
| | | | | | | | 25 | 25 | 20.8 | 17.0 | 33.0 | -16.0 |
| | | | | | | | 50 | 0 | 20.9 | 17.1 | 33.0 | -15.9 |

| Antenna gain (dBi) | | -3.80 | | | | | | | |
|--------------------|------------|-----------------|------------|---------|-----------|-------------------------|--------------------|------------------|-------------|
| Bandwidth | UL Channel | Frequency (MHz) | Modulation | RB Size | RB Offset | Conducted Average (dBm) | EIRP Average (dBm) | EIRP Limit (dBm) | Margin (dB) |
| 10.0 | 41540 | 2685.0 | QPSK | 1 | 0 | 23.6 | 19.8 | 33.0 | -13.2 |
| | | | | 1 | 25 | 23.4 | 19.6 | 33.0 | -13.4 |
| | | | | 1 | 49 | 23.4 | 19.6 | 33.0 | -13.4 |
| | | | | 25 | 0 | 23.1 | 19.3 | 33.0 | -13.7 |
| | | | | 25 | 12 | 23.1 | 19.3 | 33.0 | -13.7 |
| | | | | 25 | 25 | 23.0 | 19.2 | 33.0 | -13.8 |
| | | | | 50 | 0 | 23.1 | 19.3 | 33.0 | -13.7 |
| | | | 16QAM | 1 | 0 | 23.0 | 19.2 | 33.0 | -13.8 |
| | | | | 1 | 25 | 23.0 | 19.2 | 33.0 | -13.8 |
| | | | | 1 | 49 | 22.9 | 19.1 | 33.0 | -13.9 |
| | | | | 25 | 0 | 22.1 | 18.3 | 33.0 | -14.7 |
| | | | | 25 | 12 | 22.1 | 18.3 | 33.0 | -14.7 |
| | | | | 25 | 25 | 22.1 | 18.3 | 33.0 | -14.7 |
| | | | | 50 | 0 | 22.1 | 18.3 | 33.0 | -14.7 |
| | | | 64QAM | 1 | 0 | 21.6 | 17.8 | 33.0 | -15.2 |
| | | | | 1 | 25 | 21.6 | 17.8 | 33.0 | -15.2 |
| | | | | 1 | 49 | 21.7 | 17.9 | 33.0 | -15.1 |
| | | | | 25 | 0 | 20.6 | 16.8 | 33.0 | -16.2 |
| | | | | 25 | 12 | 20.6 | 16.8 | 33.0 | -16.2 |
| | | | | 25 | 25 | 20.5 | 16.7 | 33.0 | -16.3 |
| | | | | 50 | 0 | 20.0 | 16.2 | 33.0 | -16.8 |

| Antenna gain (dBi) | | -3.80 | | | | | | | |
|--------------------|------------|-----------------|------------|---------|-----------|-------------------------|--------------------|------------------|-------------|
| Bandwidth | UL Channel | Frequency (MHz) | Modulation | RB Size | RB Offset | Conducted Average (dBm) | EIRP Average (dBm) | EIRP Limit (dBm) | Margin (dB) |
| 15.0 | 39725 | 2503.5 | QPSK | 1 | 0 | 23.8 | 20.0 | 33.0 | -13.0 |
| | | | | 1 | 37 | 23.6 | 19.8 | 33.0 | -13.2 |
| | | | | 1 | 74 | 23.6 | 19.8 | 33.0 | -13.2 |
| | | | | 36 | 0 | 23.6 | 19.8 | 33.0 | -13.2 |
| | | | | 36 | 20 | 23.7 | 19.9 | 33.0 | -13.1 |
| | | | | 36 | 39 | 23.6 | 19.8 | 33.0 | -13.2 |
| | | | | 75 | 0 | 23.4 | 19.6 | 33.0 | -13.4 |
| | | | 16QAM | 1 | 0 | 23.3 | 19.5 | 33.0 | -13.5 |
| | | | | 1 | 37 | 23.1 | 19.3 | 33.0 | -13.7 |
| | | | | 1 | 74 | 23.0 | 19.2 | 33.0 | -13.8 |
| | | | | 36 | 0 | 22.2 | 18.4 | 33.0 | -14.6 |
| | | | | 36 | 20 | 22.2 | 18.4 | 33.0 | -14.7 |
| | | | | 36 | 39 | 22.1 | 18.3 | 33.0 | -14.7 |
| | | | | 75 | 0 | 22.2 | 18.4 | 33.0 | -14.7 |
| | | | 64QAM | 1 | 0 | 21.7 | 17.9 | 33.0 | -15.1 |
| | | | | 1 | 37 | 21.8 | 18.0 | 33.0 | -15.0 |
| | | | | 1 | 74 | 21.7 | 17.9 | 33.0 | -15.1 |
| | | | | 36 | 0 | 20.7 | 16.9 | 33.0 | -16.1 |
| | | | | 36 | 20 | 20.7 | 16.9 | 33.0 | -16.1 |
| | | | | 36 | 39 | 20.7 | 16.9 | 33.0 | -16.1 |
| | | | | 75 | 0 | 20.7 | 16.9 | 33.0 | -16.1 |
| 15.0 | 40620 | 2593.0 | QPSK | 1 | 0 | 23.9 | 20.1 | 33.0 | -12.9 |
| | | | | 1 | 37 | 23.8 | 20.0 | 33.0 | -13.0 |
| | | | | 1 | 74 | 23.7 | 19.9 | 33.0 | -13.1 |
| | | | | 36 | 0 | 23.8 | 20.0 | 33.0 | -13.0 |
| | | | | 36 | 20 | 23.8 | 20.0 | 33.0 | -13.0 |
| | | | | 36 | 39 | 23.8 | 20.0 | 33.0 | -13.0 |
| | | | | 75 | 0 | 23.7 | 19.9 | 33.0 | -13.1 |
| | | | 16QAM | 1 | 0 | 23.5 | 19.7 | 33.0 | -13.3 |
| | | | | 1 | 37 | 23.3 | 19.5 | 33.0 | -13.5 |
| | | | | 1 | 74 | 23.2 | 19.4 | 33.0 | -13.6 |
| | | | | 36 | 0 | 22.3 | 18.5 | 33.0 | -14.5 |
| | | | | 36 | 20 | 22.4 | 18.6 | 33.0 | -14.4 |
| | | | | 36 | 39 | 22.3 | 18.5 | 33.0 | -14.5 |
| | | | | 75 | 0 | 22.3 | 18.5 | 33.0 | -14.5 |
| | | | 64QAM | 1 | 0 | 22.3 | 18.5 | 33.0 | -14.5 |
| | | | | 1 | 37 | 22.0 | 18.2 | 33.0 | -14.8 |
| | | | | 1 | 74 | 21.9 | 18.1 | 33.0 | -14.9 |
| | | | | 36 | 0 | 20.9 | 17.1 | 33.0 | -15.9 |
| | | | | 36 | 20 | 20.9 | 17.1 | 33.0 | -15.9 |
| | | | | 36 | 39 | 20.8 | 17.0 | 33.0 | -16.0 |
| | | | | 75 | 0 | 20.9 | 17.1 | 33.0 | -15.9 |

| Antenna gain (dBi) | | -3.80 | | | | | | | |
|--------------------|------------|-----------------|------------|---------|-----------|-------------------------|--------------------|------------------|-------------|
| Bandwidth | UL Channel | Frequency (MHz) | Modulation | RB Size | RB Offset | Conducted Average (dBm) | EIRP Average (dBm) | EIRP Limit (dBm) | Margin (dB) |
| 15.0 | 41515 | 2682.5 | QPSK | 1 | 0 | 23.5 | 19.7 | 33.0 | -13.3 |
| | | | | 1 | 37 | 23.3 | 19.5 | 33.0 | -13.5 |
| | | | | 1 | 74 | 23.2 | 19.4 | 33.0 | -13.6 |
| | | | | 36 | 0 | 23.2 | 19.4 | 33.0 | -13.6 |
| | | | | 36 | 20 | 23.2 | 19.4 | 33.0 | -13.6 |
| | | | | 36 | 39 | 23.1 | 19.3 | 33.0 | -13.7 |
| | | | | 75 | 0 | 22.8 | 19.0 | 33.0 | -14.0 |
| | | | 16QAM | 1 | 0 | 23.2 | 19.4 | 33.0 | -13.6 |
| | | | | 1 | 37 | 22.9 | 19.1 | 33.0 | -13.9 |
| | | | | 1 | 74 | 23.0 | 19.2 | 33.0 | -13.8 |
| | | | | 36 | 0 | 22.3 | 18.5 | 33.0 | -14.5 |
| | | | | 36 | 20 | 22.2 | 18.4 | 33.0 | -14.7 |
| | | | | 36 | 39 | 22.1 | 18.3 | 33.0 | -14.7 |
| | | | | 75 | 0 | 22.0 | 18.2 | 33.0 | -14.8 |
| | | | 64QAM | 1 | 0 | 21.6 | 17.8 | 33.0 | -15.2 |
| | | | | 1 | 37 | 21.6 | 17.8 | 33.0 | -15.2 |
| | | | | 1 | 74 | 21.7 | 17.9 | 33.0 | -15.1 |
| | | | | 36 | 0 | 20.6 | 16.8 | 33.0 | -16.2 |
| | | | | 36 | 20 | 20.6 | 16.8 | 33.0 | -16.2 |
| | | | | 36 | 39 | 20.5 | 16.7 | 33.0 | -16.3 |
| | | | | 75 | 0 | 20.0 | 16.2 | 33.0 | -16.8 |

| Antenna gain (dBi) | | -3.80 | | | | | | | |
|--------------------|------------|-----------------|------------|---------|-----------|-------------------------|--------------------|------------------|-------------|
| Bandwidth | UL Channel | Frequency (MHz) | Modulation | RB Size | RB Offset | Conducted Average (dBm) | EIRP Average (dBm) | EIRP Limit (dBm) | Margin (dB) |
| 20.0 | 39750 | 2506.0 | QPSK | 1 | 0 | 23.8 | 20.0 | 33.0 | -13.0 |
| | | | | 1 | 49 | 23.6 | 19.8 | 33.0 | -13.2 |
| | | | | 1 | 99 | 23.5 | 19.7 | 33.0 | -13.3 |
| | | | | 50 | 0 | 23.6 | 19.8 | 33.0 | -13.2 |
| | | | | 50 | 24 | 23.6 | 19.8 | 33.0 | -13.2 |
| | | | | 50 | 50 | 23.5 | 19.7 | 33.0 | -13.3 |
| | | | 16QAM | 100 | 0 | 23.4 | 19.6 | 33.0 | -13.4 |
| | | | | 1 | 0 | 23.1 | 19.3 | 33.0 | -13.7 |
| | | | | 1 | 49 | 22.9 | 19.1 | 33.0 | -13.9 |
| | | | | 1 | 99 | 22.8 | 19.0 | 33.0 | -14.0 |
| | | | | 50 | 0 | 22.2 | 18.4 | 33.0 | -14.6 |
| | | | | 50 | 24 | 22.1 | 18.3 | 33.0 | -14.7 |
| | | | 64QAM | 50 | 50 | 22.0 | 18.2 | 33.0 | -14.8 |
| | | | | 100 | 0 | 22.1 | 18.3 | 33.0 | -14.7 |
| | | | | 1 | 0 | 21.7 | 17.9 | 33.0 | -15.1 |
| | | | | 1 | 49 | 21.8 | 18.0 | 33.0 | -15.0 |
| | | | | 1 | 99 | 21.7 | 17.9 | 33.0 | -15.1 |
| | | | | 50 | 0 | 20.7 | 16.9 | 33.0 | -16.1 |
| 20.0 | 40620 | 2593.0 | QPSK | 50 | 24 | 20.7 | 16.9 | 33.0 | -16.1 |
| | | | | 50 | 50 | 20.7 | 16.9 | 33.0 | -16.1 |
| | | | | 100 | 0 | 20.7 | 16.9 | 33.0 | -16.1 |
| | | | | 1 | 0 | 23.9 | 20.1 | 33.0 | -12.9 |
| | | | | 1 | 49 | 23.7 | 19.9 | 33.0 | -13.1 |
| | | | | 1 | 99 | 23.6 | 19.8 | 33.0 | -13.2 |
| | | | 16QAM | 50 | 0 | 23.8 | 20.0 | 33.0 | -13.0 |
| | | | | 50 | 24 | 23.8 | 20.0 | 33.0 | -13.0 |
| | | | | 50 | 50 | 23.7 | 19.9 | 33.0 | -13.1 |
| | | | | 100 | 0 | 23.7 | 19.9 | 33.0 | -13.1 |
| | | | | 1 | 0 | 23.4 | 19.6 | 33.0 | -13.4 |
| | | | | 1 | 49 | 23.2 | 19.4 | 33.0 | -13.6 |
| | | | 64QAM | 1 | 99 | 23.1 | 19.3 | 33.0 | -13.7 |
| | | | | 50 | 0 | 22.3 | 18.5 | 33.0 | -14.5 |
| | | | | 50 | 24 | 22.3 | 18.5 | 33.0 | -14.6 |
| | | | | 50 | 50 | 22.2 | 18.4 | 33.0 | -14.7 |
| | | | | 100 | 0 | 22.3 | 18.5 | 33.0 | -14.5 |
| | | | | 1 | 0 | 22.3 | 18.5 | 33.0 | -14.5 |
| 64QAM | 1 | 49 | 22.0 | 18.2 | 33.0 | -14.8 | | | |
| | 1 | 99 | 21.9 | 18.1 | 33.0 | -14.9 | | | |
| | 50 | 0 | 20.9 | 17.1 | 33.0 | -15.9 | | | |
| | 50 | 24 | 20.9 | 17.1 | 33.0 | -15.9 | | | |
| | 50 | 50 | 20.8 | 17.0 | 33.0 | -16.0 | | | |
| | 100 | 0 | 20.9 | 17.1 | 33.0 | -15.9 | | | |

| Antenna gain (dBi) | | -3.80 | | | | | | | |
|--------------------|------------|--------|------------|---------|-----------|-------------------------|--------------------|------------------|-------------|
| Bandwidth | UL Channel | -1.5 | Modulation | RB Size | RB Offset | Conducted Average (dBm) | EIRP Average (dBm) | EIRP Limit (dBm) | Margin (dB) |
| 20.0 | 41490 | 2680.0 | QPSK | 1 | 0 | 23.8 | 20.0 | 33.0 | -13.0 |
| | | | | 1 | 49 | 23.6 | 19.8 | 33.0 | -13.2 |
| | | | | 1 | 99 | 23.4 | 19.6 | 33.0 | -13.4 |
| | | | | 50 | 0 | 23.7 | 19.9 | 33.0 | -13.2 |
| | | | | 50 | 24 | 23.6 | 19.8 | 33.0 | -13.2 |
| | | | | 50 | 50 | 23.4 | 19.6 | 33.0 | -13.4 |
| | | | | 100 | 0 | 23.3 | 19.5 | 33.0 | -13.5 |
| | | | 16QAM | 1 | 0 | 23.5 | 19.7 | 33.0 | -13.3 |
| | | | | 1 | 49 | 23.2 | 19.4 | 33.0 | -13.6 |
| | | | | 1 | 99 | 22.9 | 19.1 | 33.0 | -13.9 |
| | | | | 50 | 0 | 22.2 | 18.4 | 33.0 | -14.6 |
| | | | | 50 | 24 | 22.2 | 18.4 | 33.0 | -14.6 |
| | | | | 50 | 50 | 22.0 | 18.2 | 33.0 | -14.8 |
| | | | | 100 | 0 | 22.1 | 18.3 | 33.0 | -14.7 |
| | | | 64QAM | 1 | 0 | 21.4 | 17.6 | 33.0 | -15.4 |
| | | | | 1 | 49 | 21.3 | 17.5 | 33.0 | -15.5 |
| | | | | 1 | 99 | 21.1 | 17.3 | 33.0 | -15.7 |
| | | | | 50 | 0 | 20.3 | 16.5 | 33.0 | -16.5 |
| | | | | 50 | 24 | 20.3 | 16.5 | 33.0 | -16.5 |
| | | | | 50 | 50 | 20.2 | 16.4 | 33.0 | -16.6 |
| | | | | 100 | 0 | 20.2 | 16.4 | 33.0 | -16.6 |

13. PEAK TO AVERAGE RATIO

TEST PROCEDURE

Per KDB 971168 D01 Power Meas License Digital Systems v02r02

TEST SPEC

In addition, when the transmitter power is measured in terms of average value, the peak-to-average ratio of the power shall not exceed 13 dB.

13.1. CONDUCTED PEAK TO AVERAGE RESULT

GSM

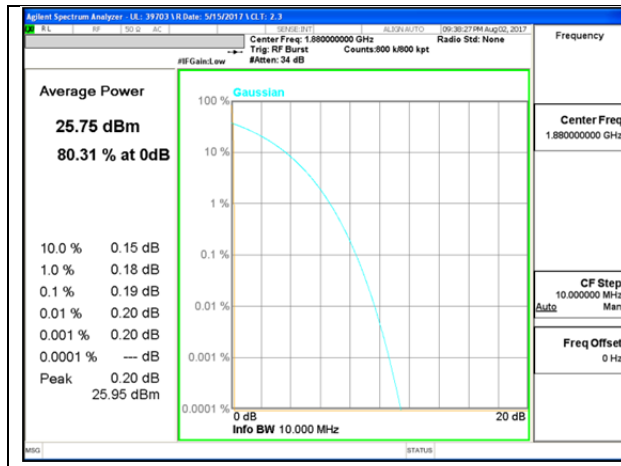

GSM1900 GPRS Middle Channel

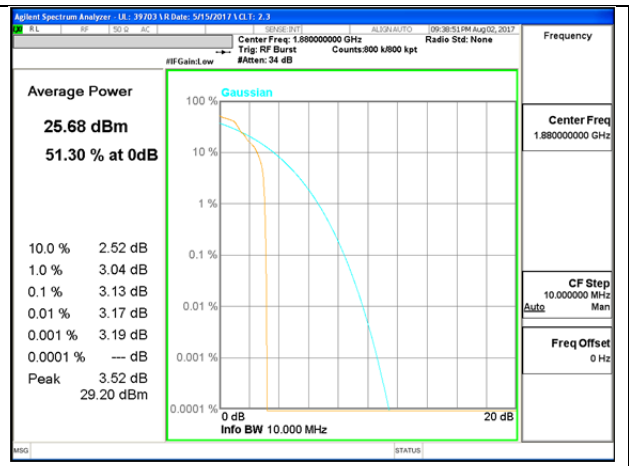

GSM1900 EGPRS Middle Channel

WCDMA

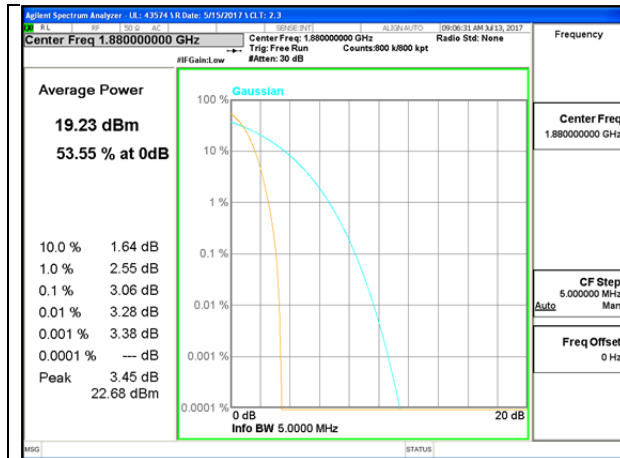

B2 REL99

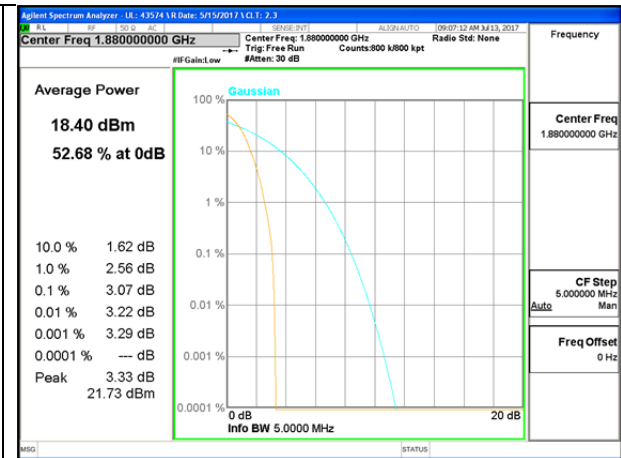

B2 HSDPA

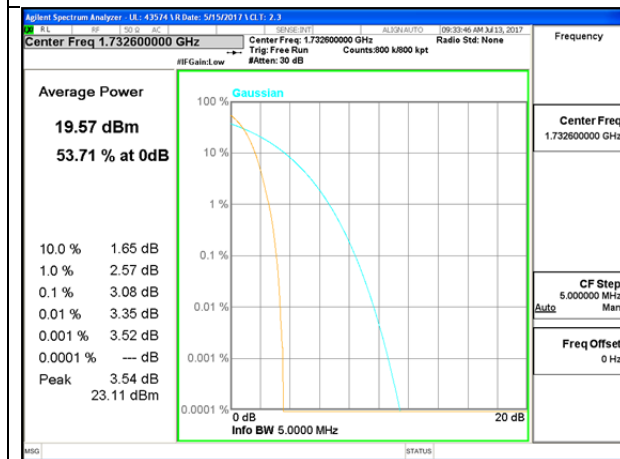

B4 REL99

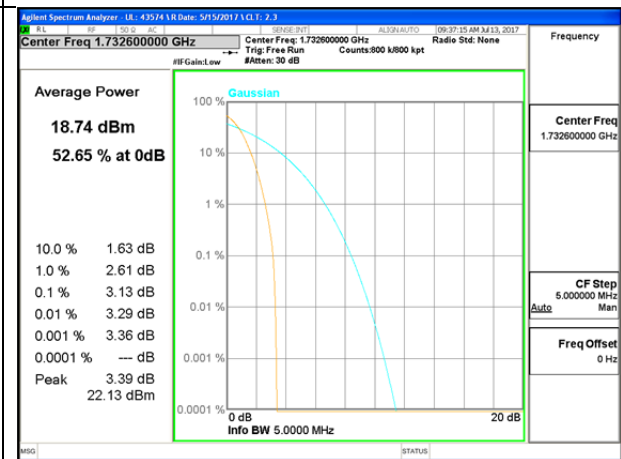

B4 HSDPA

LTE Band 2

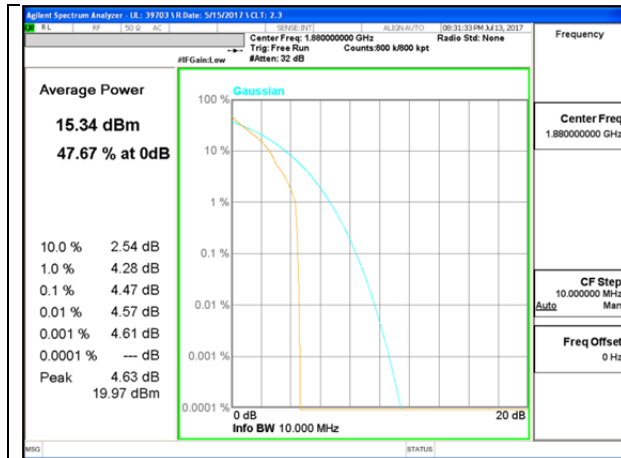

LTE B2 1.4MHz QPSK Middle Channel

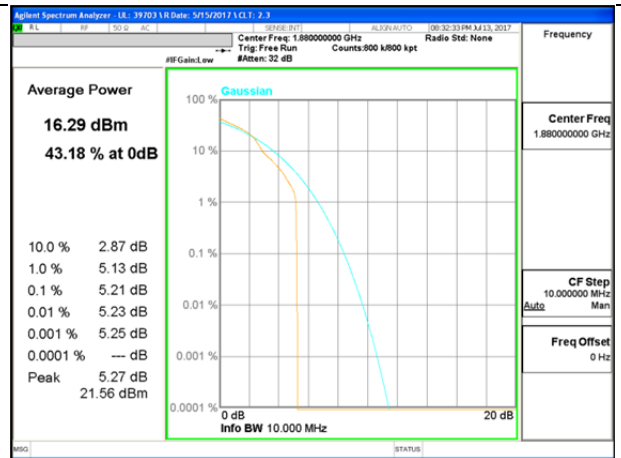

LTE B2 1.4MHz 16QAM Middle Channel

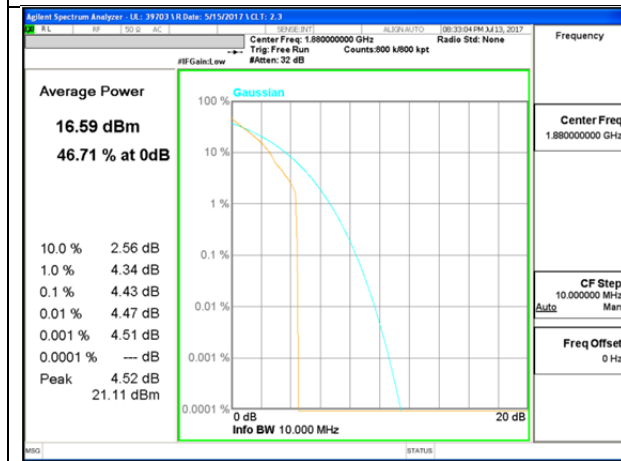

LTE B2 3MHz QPSK Middle Channel

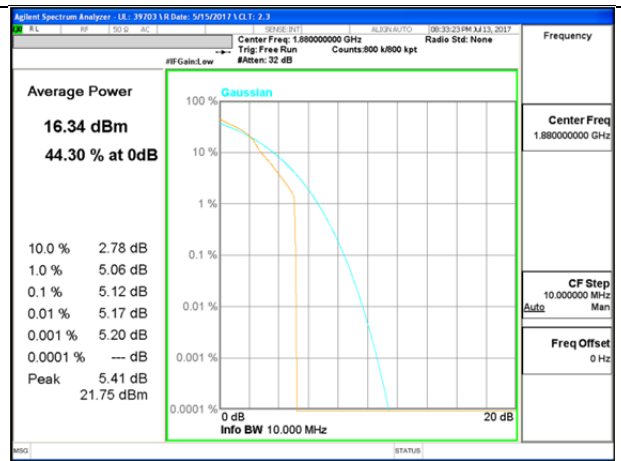

LTE B2 3MHz 16QAM Middle Channel



LTE B2 5MHz QPSK Middle Channel

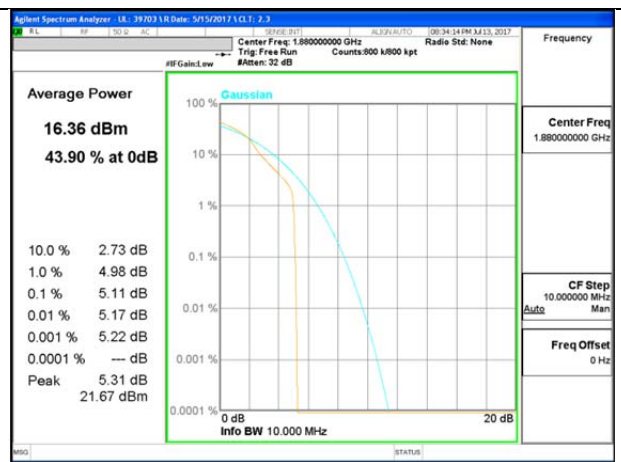

LTE B2 5MHz 16QAM Middle Channel

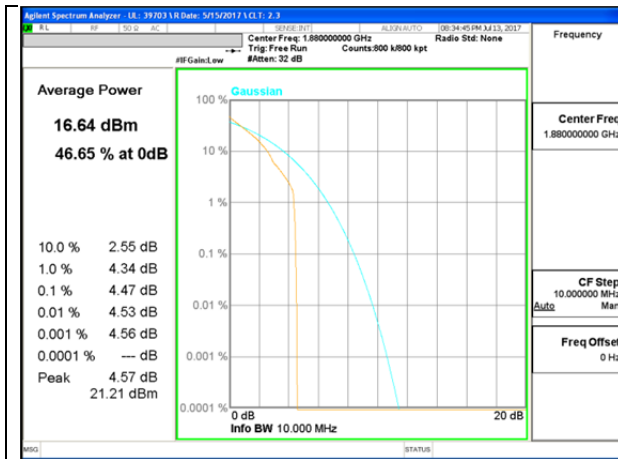

LTE B2 10MHz QPSK Middle Channel

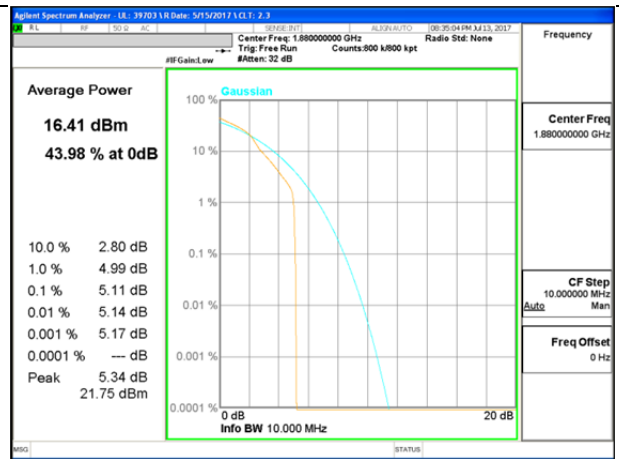

LTE B2 10MHz 16QAM Middle Channel

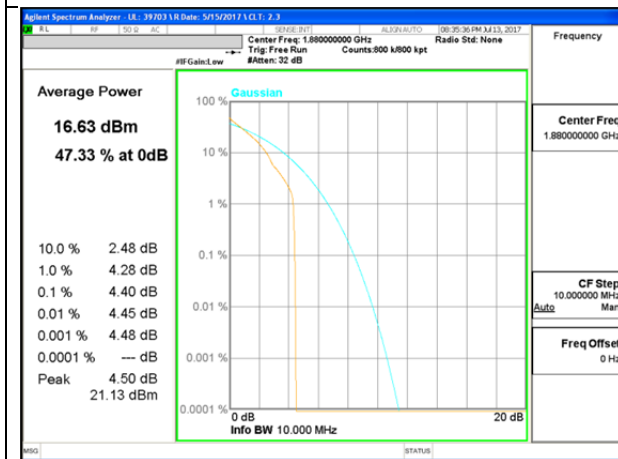

LTE B2 15MHz QPSK Middle Channel



LTE B2 15MHz 16QAM Middle Channel

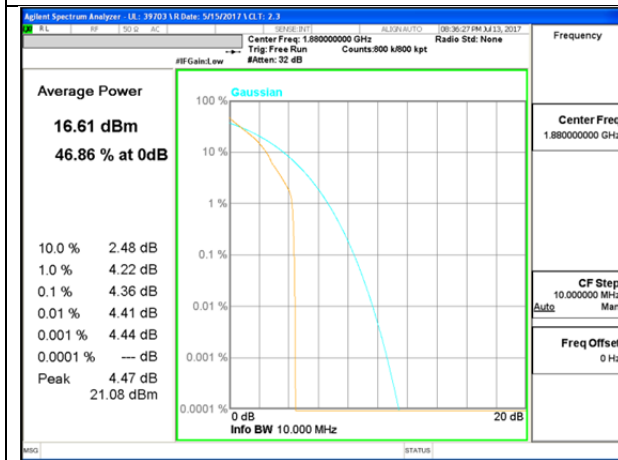

LTE B2 20MHz QPSK Middle Channel

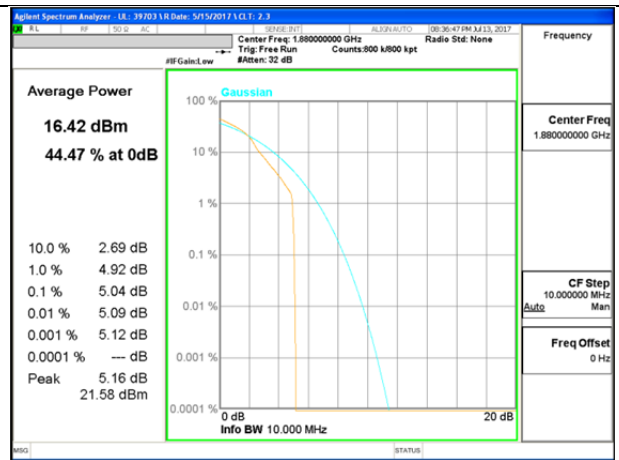

LTE B2 20MHz 16QAM Middle Channel

LTE Band 4

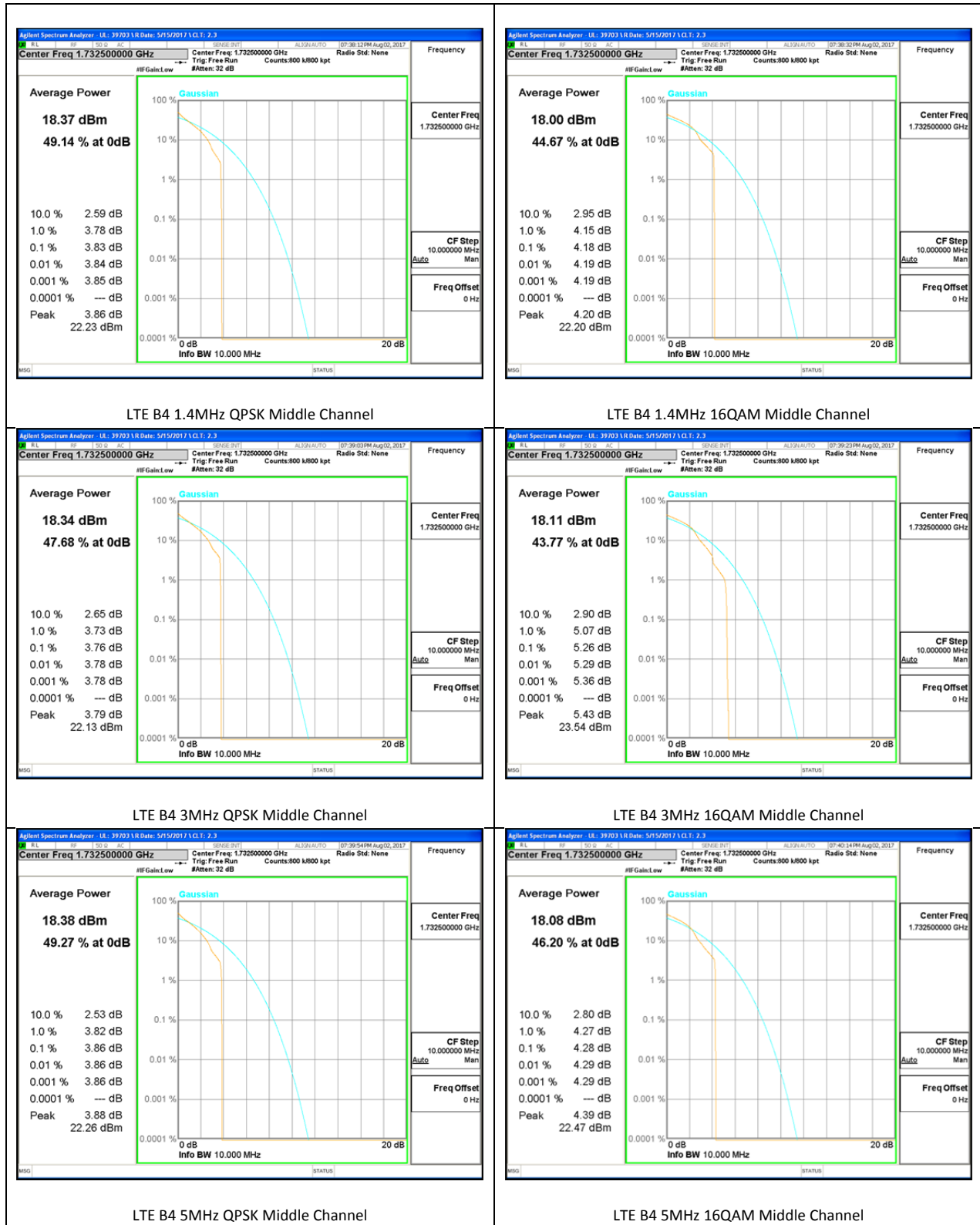

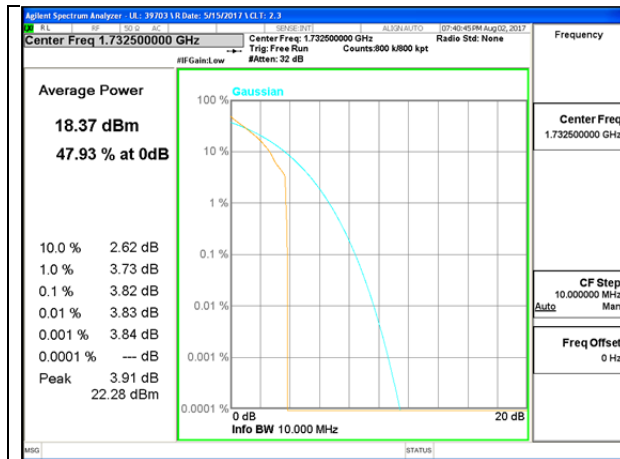

LTE B4 10MHz QPSK Middle Channel

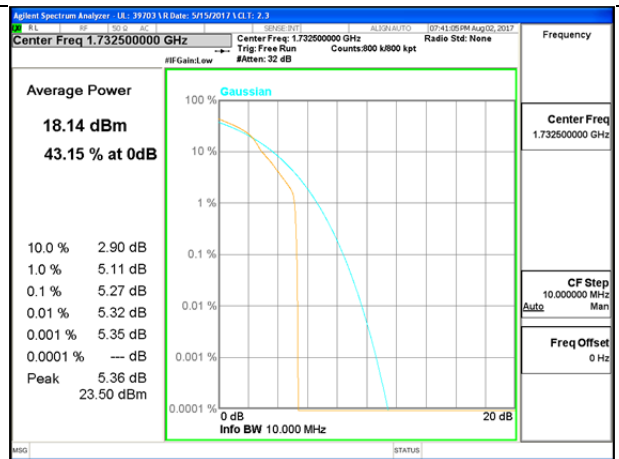

LTE B4 10MHz 16QAM Middle Channel

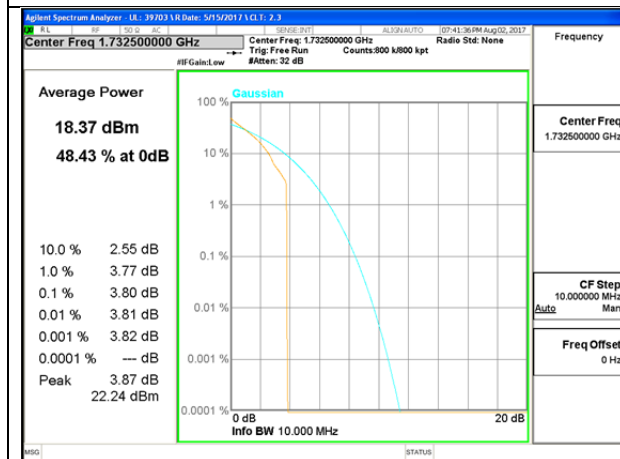

LTE B4 15MHz QPSK Middle Channel

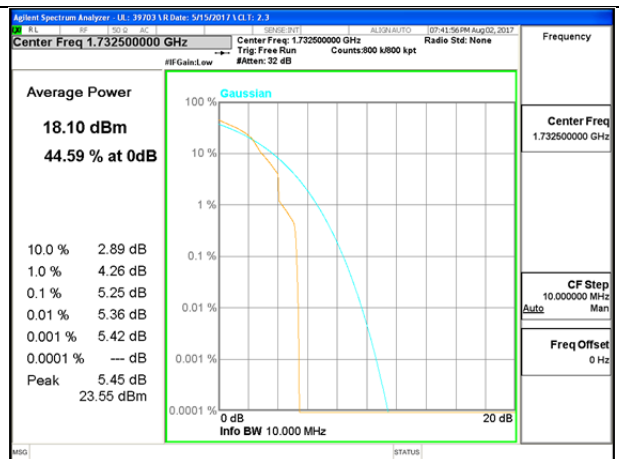

LTE B4 15MHz 16QAM Middle Channel

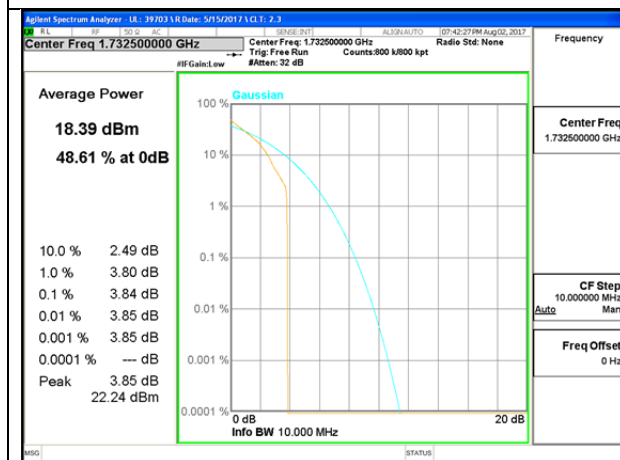

LTE B4 20MHz QPSK Middle Channel

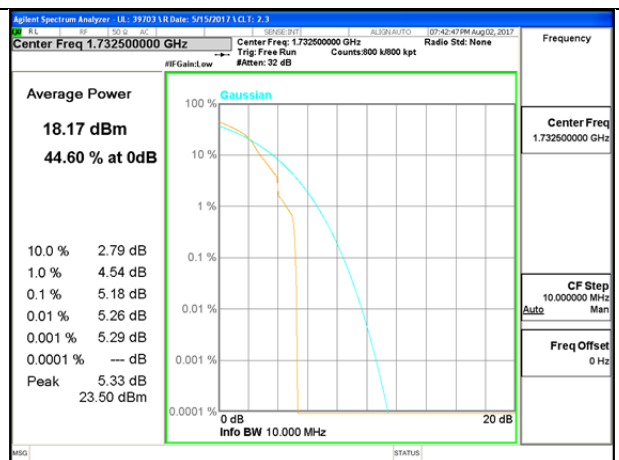

LTE B4 20MHz 16QAM Middle Channel

LTE Band 41

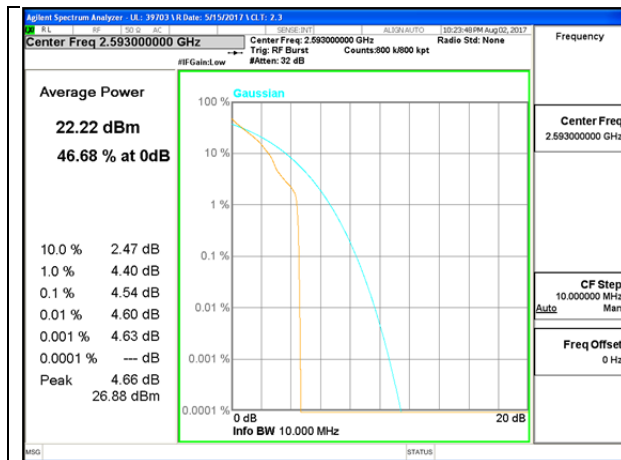

LTE B41 5MHz QPSK Middle Channel

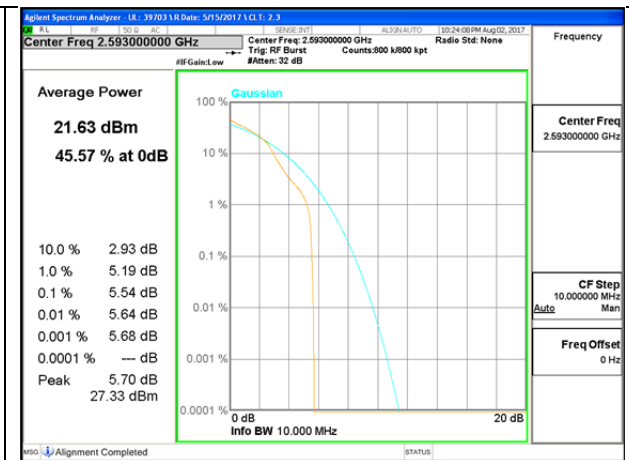

LTE B41 5MHz 16QAM Middle Channel

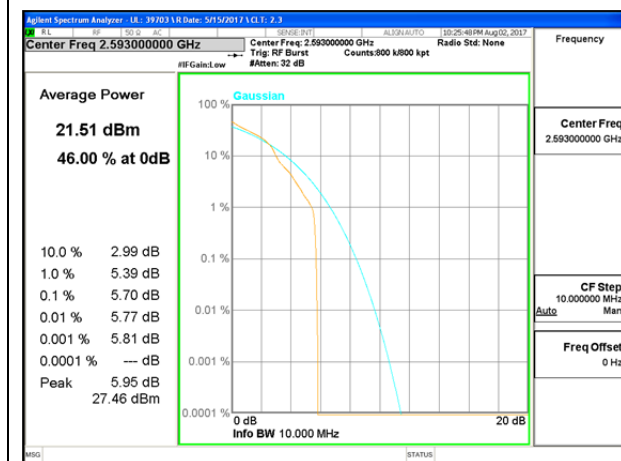

LTE B41 10MHz QPSK Middle Channel

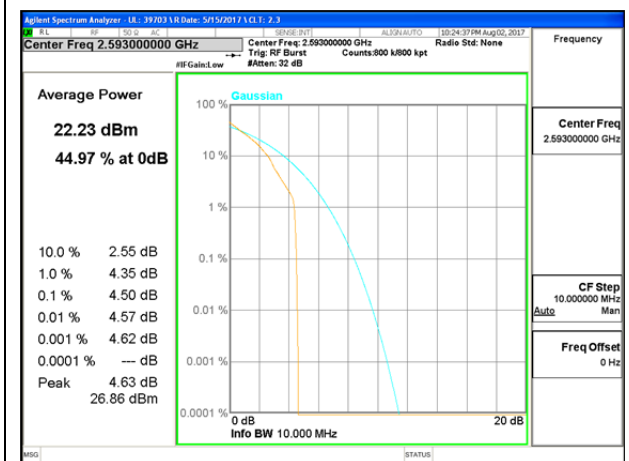

LTE B41 10MHz 16QAM Middle Channel

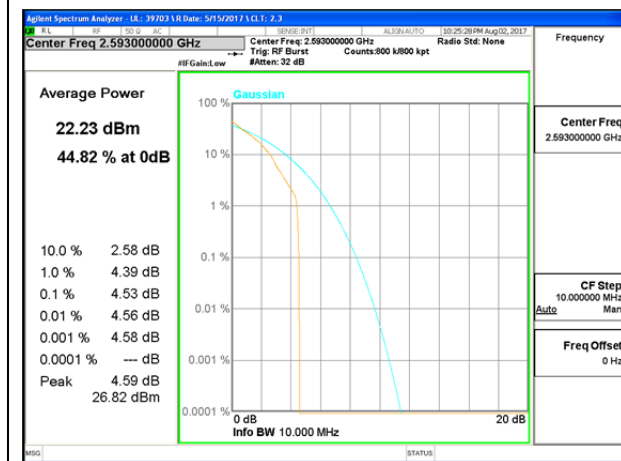

LTE B41 15MHz QPSK Middle Channel

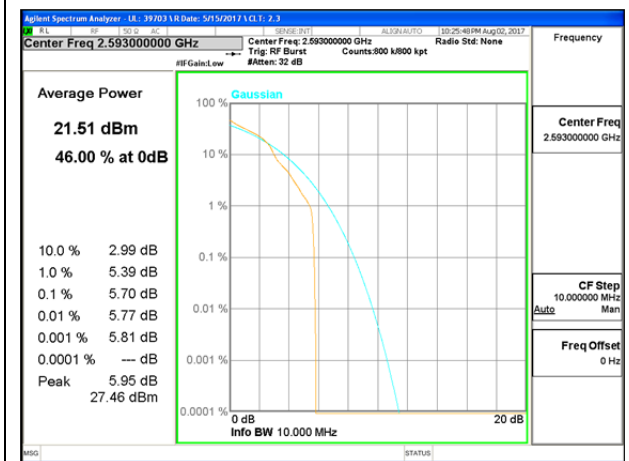

LTE B41 15MHz 16QAM Middle Channel

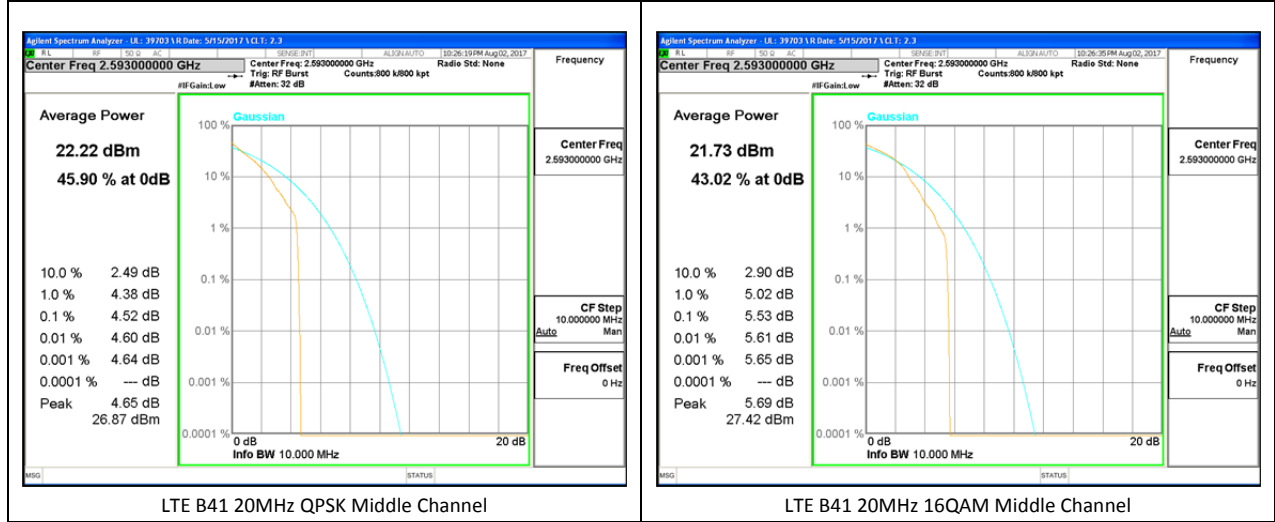

14. OCCUPIED BANDWIDTH

RULE PART(S)

FCC: §2.1049

LIMITS

For reporting purposes only

TEST PROCEDURE

The transmitter output was connected to a calibrated coaxial cable and coupler, the other end of which was connected to a spectrum analyzer. The occupied bandwidth was measured with the spectrum analyzer at the low, middle and high channel in each band. The -26dB bandwidth was also measured and recorded.

(KDB 971168 D01 Power Meas License Digital Systems v02r02)

14.1. OCCUPIED BANDWIDTH RESULTS AND PLOTS

GSM

| Band | Mode | Channel | f (MHz) | 99% BW (kHz) | -26dB (kHz) |
|----------|-------|---------|---------|--------------|-------------|
| GSM 1900 | GPRS | 512 | 1850.2 | 245.4 | 314.2 |
| | | 661 | 1880 | 242.4 | 322.7 |
| | | 810 | 1909.8 | 246.9 | 311.7 |
| | EGPRS | 512 | 1850.2 | 239.9 | 318 |
| | | 661 | 1880 | 245.3 | 308.3 |
| | | 810 | 1909.8 | 244.9 | 308.6 |

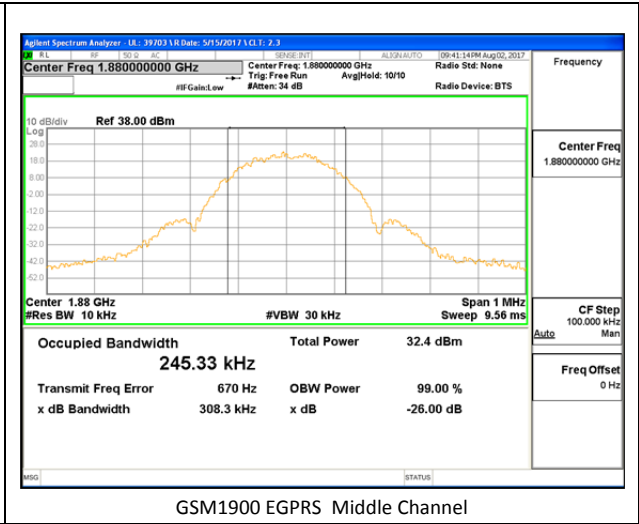
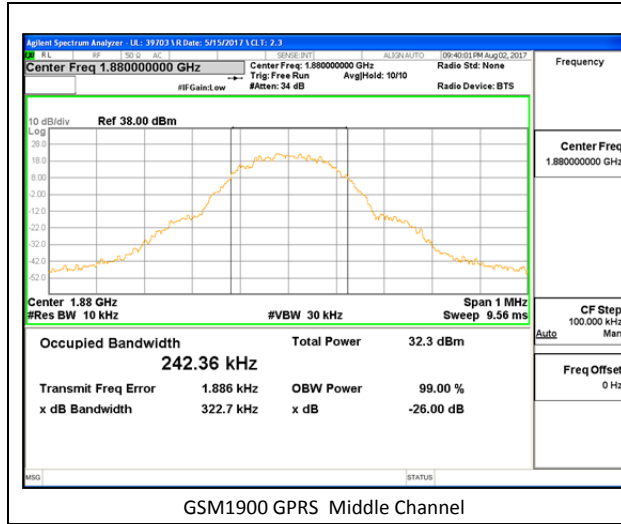

WCDMA

| Band | Mode | Channel | f (MHz) | 99% BW (MHz) | -26dB (MHz) |
|--------|-------|---------|---------|--------------|-------------|
| Band 2 | REL99 | 9262 | 1852.4 | 4.126 | 4.697 |
| | | 9400 | 1880 | 4.131 | 4.718 |
| | | 9538 | 1907.6 | 4.116 | 4.692 |
| | HSDPA | 9262 | 1852.4 | 4.127 | 4.699 |
| | | 9400 | 1880 | 4.137 | 4.706 |
| | | 9538 | 1907.6 | 4.134 | 4.689 |
| Band 4 | REL99 | 9262 | 1712.4 | 4.119 | 4.698 |
| | | 9400 | 1732.6 | 4.124 | 4.691 |
| | | 9538 | 1752.6 | 4.122 | 4.674 |
| | HSDPA | 9262 | 1712.4 | 4.145 | 4.696 |
| | | 9400 | 1732.6 | 4.138 | 4.686 |
| | | 9538 | 1752.6 | 4.14 | 4.691 |

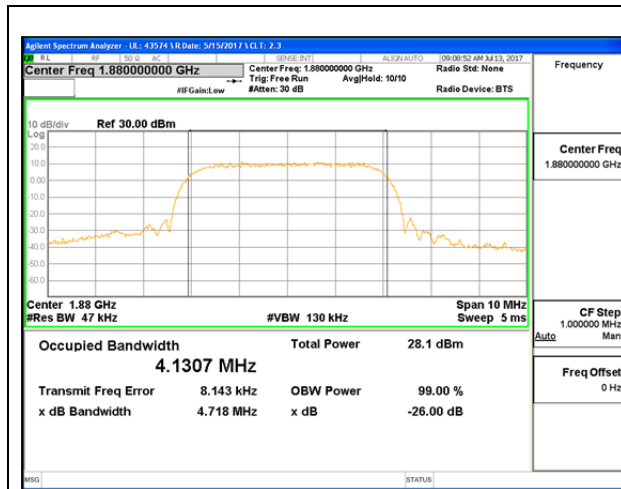

B2 REL99 Middle Channel

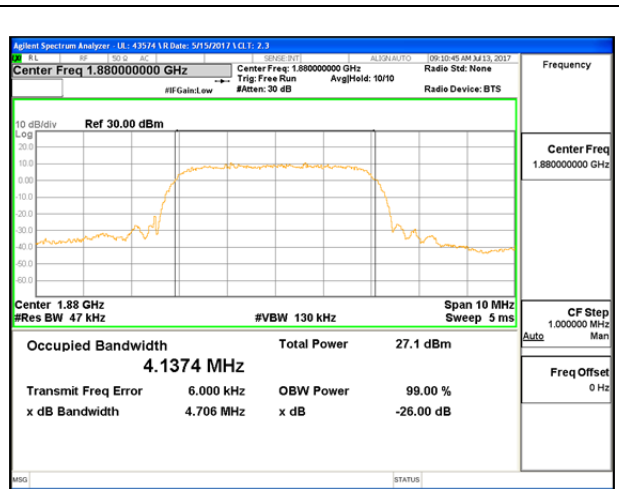

B2 HSDPA Middle Channel

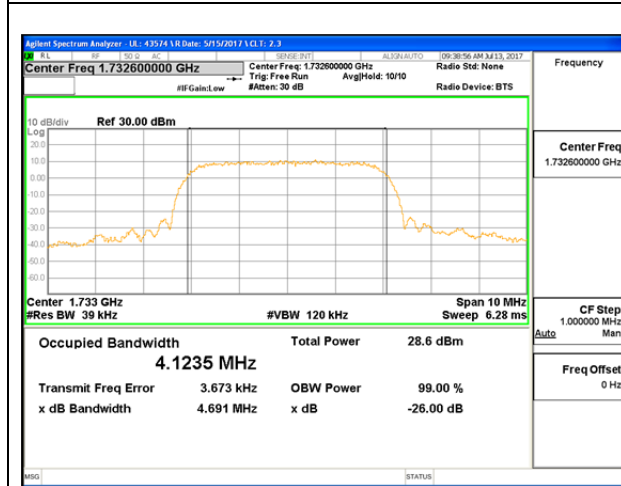

B4 REL99 Middle Channel

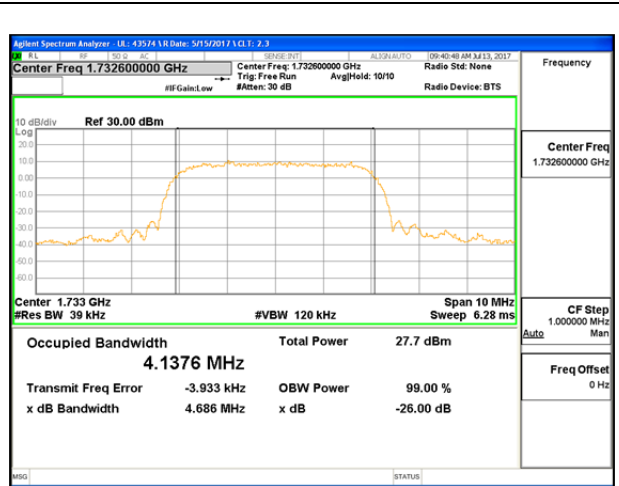

B4 HSDPA Middle Channel

LTE Band 2

| Band | BW(MHz) | Mode | RB/RB Size | f (MHz) | 99% BW (MHz) | -26dB BW (MHz) |
|-------|---------|-------|------------|---------|--------------|----------------|
| LTE2 | 1.4 | QPSK | 6/0 | 1850.7 | 1.1 | 1.25 |
| | | | 6/0 | 1880 | 1.08 | 1.23 |
| | | | 6/0 | 1909.3 | 1.09 | 1.23 |
| | | 16QAM | 6/0 | 1850.7 | 1.08 | 1.24 |
| | | | 6/0 | 1880 | 1.08 | 1.23 |
| | | | 6/0 | 1909.3 | 1.09 | 1.24 |
| | 3 | QPSK | 15/0 | 1851.5 | 2.7 | 3.0 |
| | | | 15/0 | 1880 | 2.7 | 3.0 |
| | | | 15/0 | 1908.5 | 2.7 | 2.98 |
| | | 16QAM | 15/0 | 1851.5 | 2.7 | 3.01 |
| | | | 15/0 | 1880 | 2.7 | 3.0 |
| | | | 15/0 | 1908.5 | 2.69 | 3.0 |
| | 5 | QPSK | 25/0 | 1852.5 | 4.52 | 4.92 |
| | | | 25/0 | 1880 | 4.49 | 4.95 |
| | | | 25/0 | 1907.5 | 4.5 | 4.93 |
| | | 16QAM | 25/0 | 1852.5 | 4.5 | 4.98 |
| | | | 25/0 | 1880 | 4.49 | 4.94 |
| | | | 25/0 | 1907.5 | 4.48 | 4.91 |
| | 10 | QPSK | 50/0 | 1855 | 8.96 | 9.8 |
| | | | 50/0 | 1880 | 8.97 | 9.77 |
| | | | 50/0 | 1905 | 8.98 | 9.74 |
| 16QAM | | 50/0 | 1855 | 8.96 | 9.72 | |
| | | 50/0 | 1880 | 8.94 | 9.72 | |
| | | 50/0 | 1905 | 8.98 | 9.79 | |

| Band | BW(MHz) | Mode | RB/RB Size | f (MHz) | 99% BW (MHz) | -26dB BW (MHz) |
|------|---------|-------|------------|---------|--------------|----------------|
| LTE2 | 15 | QPSK | 75/0 | 1857.5 | 13.41 | 14.56 |
| | | | 75/0 | 1880 | 13.42 | 14.59 |
| | | | 75/0 | 1902.5 | 13.42 | 14.55 |
| | | 16QAM | 75/0 | 1857.5 | 13.43 | 14.56 |
| | | | 75/0 | 1880 | 13.45 | 14.46 |
| | | | 75/0 | 1902.5 | 13.44 | 14.5 |
| | 20 | QPSK | 100/0 | 1860 | 17.9 | 19.31 |
| | | | 100/0 | 1880 | 17.9 | 19.22 |
| | | | 100/0 | 1900 | 17.87 | 19.28 |
| | | 16QAM | 100/0 | 1860 | 17.9 | 19.34 |
| | | | 100/0 | 1880 | 17.88 | 19.33 |
| | | | 100/0 | 1900 | 17.88 | 19.3 |

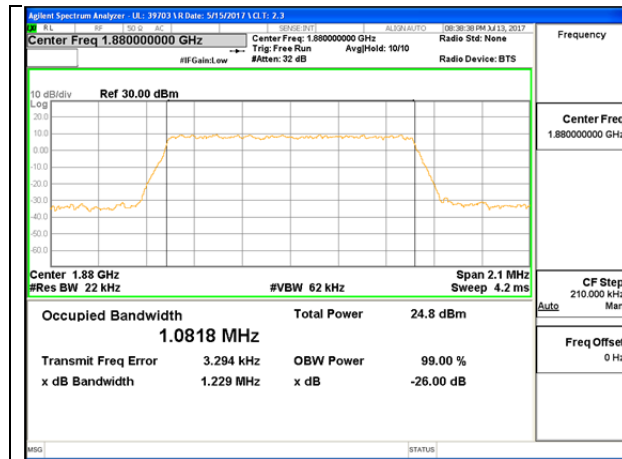

LTE B2 1.4MHz QPSK Middle Channel

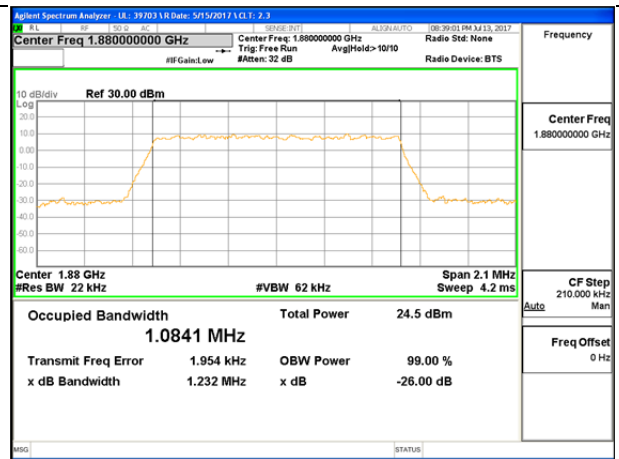

LTE B2 1.4MHz 16QAM Middle Channel

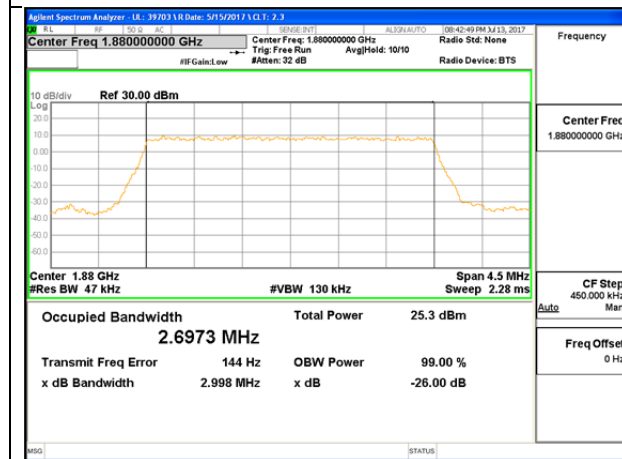

LTE B2 3MHz QPSK Middle Channel

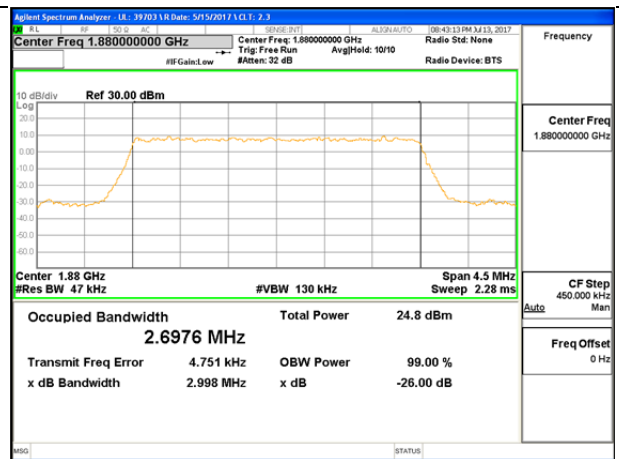

LTE B2 3MHz 16QAM Middle Channel

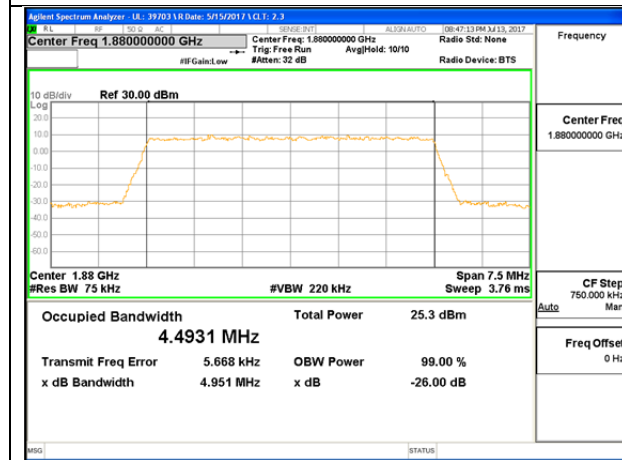

LTE B2 5MHz QPSK Middle Channel

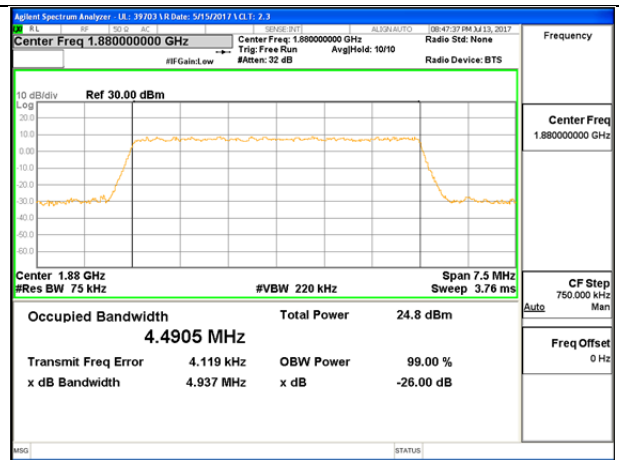

LTE B2 5MHz 16QAM Middle Channel

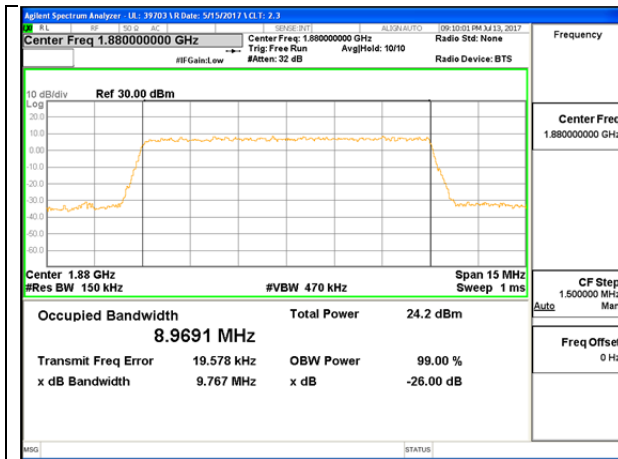

LTE B2 10MHz QPSK Middle Channel

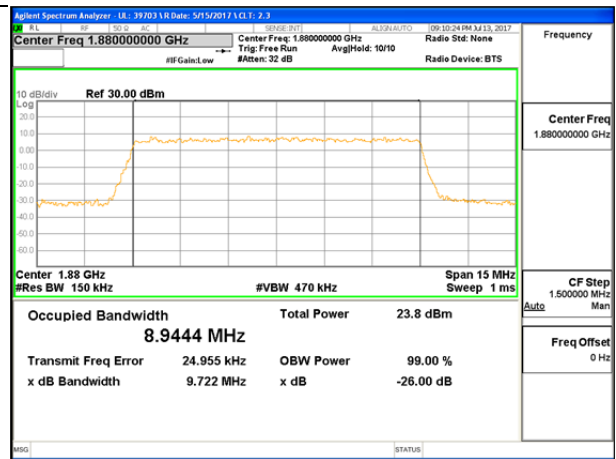

LTE B2 10MHz 16QAM Middle Channel

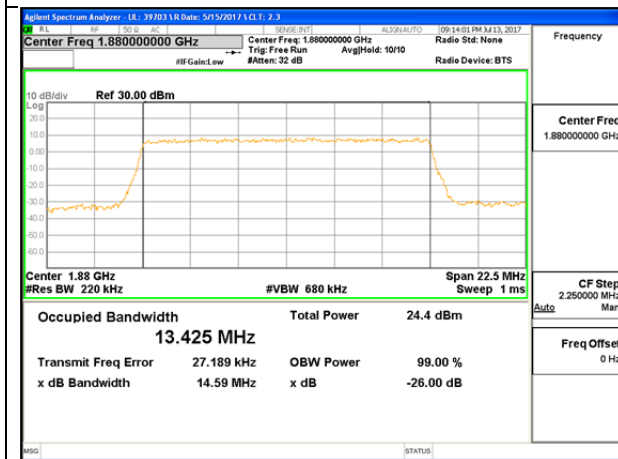

LTE B2 15MHz QPSK Middle Channel

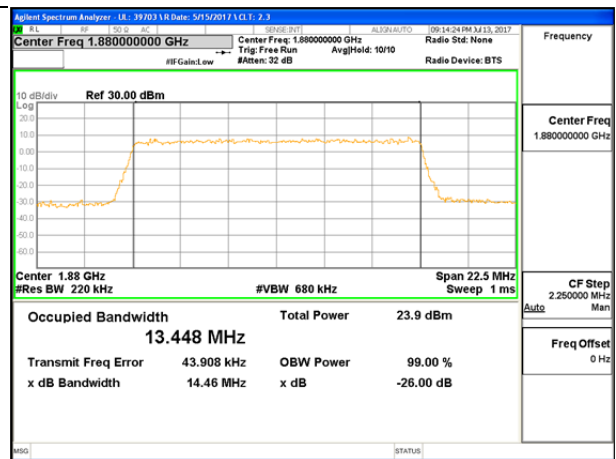

LTE B2 15MHz 16QAM Middle Channel

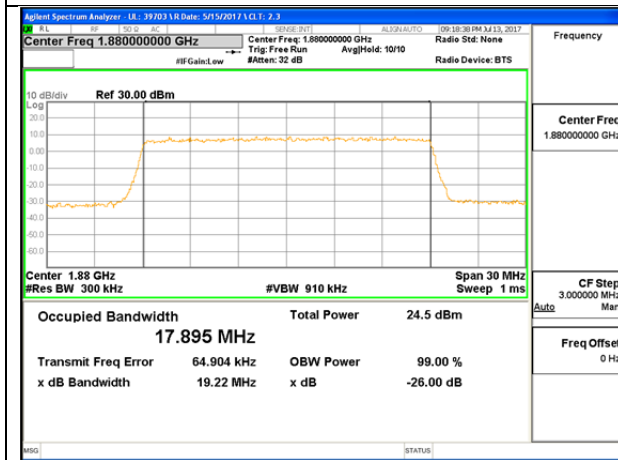

LTE B25 20MHz QPSK Middle Channel

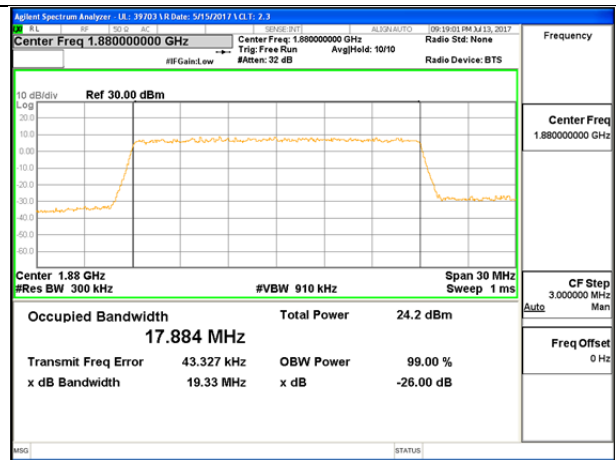

LTE B2 20MHz 16QAM Middle Channel

LTE Band 4

| Band | BW(MHz) | Mode | RB/RB Size | f (MHz) | 99% BW (MHz) | -26dB BW (MHz) |
|-------|---------|-------|------------|---------|--------------|----------------|
| LTE4 | 1.4 | QPSK | 6/0 | 1710.7 | 1.09 | 1.24 |
| | | | 6/0 | 1732.5 | 1.08 | 1.23 |
| | | | 6/0 | 1754.3 | 1.09 | 1.22 |
| | | 16QAM | 6/0 | 1710.7 | 1.08 | 1.24 |
| | | | 6/0 | 1732.5 | 1.08 | 1.23 |
| | | | 6/0 | 1754.3 | 1.09 | 1.23 |
| | 3 | QPSK | 15/0 | 1711.5 | 2.7 | 3 |
| | | | 15/0 | 1732.5 | 2.7 | 2.99 |
| | | | 15/0 | 1753.5 | 2.7 | 2.99 |
| | | 16QAM | 15/0 | 1711.5 | 2.7 | 2.98 |
| | | | 15/0 | 1732.5 | 2.7 | 2.99 |
| | | | 15/0 | 1753.5 | 2.69 | 3 |
| | 5 | QPSK | 25/0 | 1712.5 | 4.5 | 4.94 |
| | | | 25/0 | 1732.5 | 4.49 | 4.93 |
| | | | 25/0 | 1752.5 | 4.5 | 4.91 |
| | | 16QAM | 25/0 | 1712.5 | 4.5 | 4.97 |
| | | | 25/0 | 1732.5 | 4.49 | 4.93 |
| | | | 25/0 | 1752.5 | 4.48 | 4.9 |
| | 10 | QPSK | 50/0 | 1715 | 8.96 | 9.79 |
| | | | 50/0 | 1732.5 | 8.96 | 9.84 |
| | | | 50/0 | 1750 | 8.97 | 9.82 |
| 16QAM | | 50/0 | 1715 | 8.99 | 9.74 | |
| | | 50/0 | 1732.5 | 8.97 | 9.76 | |
| | | 50/0 | 1750 | 8.95 | 9.79 | |

| Band | BW(MHz) | Mode | RB/RB Size | f (MHz) | 99% BW (MHz) | -26dB BW (MHz) |
|------|---------|-------|------------|---------|--------------|----------------|
| LTE4 | 15 | QPSK | 75/0 | 1717.5 | 13.44 | 14.65 |
| | | | 75/0 | 1732.5 | 13.45 | 14.52 |
| | | | 75/0 | 1747.5 | 13.42 | 14.56 |
| | | 16QAM | 75/0 | 1717.5 | 13.44 | 14.51 |
| | | | 75/0 | 1732.5 | 13.44 | 14.57 |
| | | | 75/0 | 1747.5 | 13.42 | 14.58 |
| | 20 | QPSK | 100/0 | 1720 | 17.91 | 19.37 |
| | | | 100/0 | 1732.5 | 17.87 | 19.19 |
| | | | 100/0 | 1745 | 17.86 | 19.27 |
| | | 16QAM | 100/0 | 1720 | 17.89 | 19.33 |
| | | | 100/0 | 1732.5 | 17.89 | 19.33 |
| | | | 100/0 | 1745 | 17.87 | 19.36 |

