



# FCC RF Test Report

**APPLICANT** : Sony Mobile Communications Inc.  
**EQUIPMENT** : Bluetooth device  
**BRAND NAME** : SONY  
**FCC ID** : PY7-87507R  
**STANDARD** : FCC Part 15 Subpart C §15.247  
**CLASSIFICATION** : (DTS) Digital Transmission System

The product was received on Mar. 01, 2017 and testing was completed on Apr. 18, 2017. We, SPORTON INTERNATIONAL INC., would like to declare that the tested sample has been evaluated in accordance with the test procedures and has been in compliance with the applicable technical standards.

The test results in this report apply exclusively to the tested model / sample. Without written approval of SPORTON INTERNATIONAL INC., the test report shall not be reproduced except in full.

Reviewed by: Joseph Lin / Supervisor

Approved by: Jones Tsai / Manager



## **SPORTON INTERNATIONAL INC.**

**No. 52, Hwa Ya 1<sup>st</sup> Rd., Hwa Ya Technology Park, Kwei-Shan District, Tao Yuan City, Taiwan, R.O.C.**

**SPORTON INTERNATIONAL INC.**

TEL : 886-3-327-3456

FAX : 886-3-328-4978

FCC ID : PY7-87507R

Page Number : 1 of 37

Report Issued Date : Apr. 19, 2017

Report Version : Rev. 02

Report Template No.: BU5-FR15CBT4.0 Version 1.3



# TABLE OF CONTENTS

**REVISION HISTORY.....3**

**SUMMARY OF TEST RESULT .....4**

**1 GENERAL DESCRIPTION.....5**

    1.1 Applicant .....5

    1.2 Manufacturer.....5

    1.3 Product Feature of Equipment Under Test.....5

    1.4 Modification of EUT .....5

    1.5 Testing Location .....6

    1.6 Applicable Standards.....7

**2 TEST CONFIGURATION OF EQUIPMENT UNDER TEST.....8**

    2.1 Carrier Frequency Channel .....8

    2.2 Descriptions of Test Mode .....9

    2.3 Test Mode.....9

    2.4 Connection Diagram of Test System.....10

    2.5 Support Unit used in test configuration and system .....11

    2.6 EUT Operation Test Setup .....11

    2.7 Measurement Results Explanation Example.....11

**3 TEST RESULT .....12**

    3.1 6dB and 99% Bandwidth Measurement .....12

    3.2 Peak Output Power Measurement .....17

    3.3 Power Spectral Density Measurement .....18

    3.4 Conducted Band Edges and Spurious Emission Measurement .....23

    3.5 Radiated Band Edges and Spurious Emission Measurement .....28

    3.6 AC Conducted Emission Measurement.....32

    3.7 Antenna Requirements.....34

**4 LIST OF MEASURING EQUIPMENT.....35**

**5 UNCERTAINTY OF EVALUATION.....37**

**APPENDIX A. CONDUCTED TEST RESULTS**

**APPENDIX B. AC CONDUCTED EMISSION TEST RESULT**

**APPENDIX C. RADIATED SPURIOUS EMISSION**

**APPENDIX D. RADIATED SPURIOUS EMISSION PLOTS**

**APPENDIX E. DUTY CYCLE PLOTS**





### SUMMARY OF TEST RESULT

Report Section	FCC Rule	Description	Limit	Result	Remark
3.1	15.247(a)(2)	6dB Bandwidth	$\geq 0.5\text{MHz}$	Pass	-
3.1	-	99% Bandwidth	-	Pass	-
3.2	15.247(b)(3)	Peak Output Power	$\leq 30\text{dBm}$	Pass	-
3.3	15.247(e)	Power Spectral Density	$\leq 8\text{dBm}/3\text{kHz}$	Pass	-
3.4	15.247(d)	Conducted Band Edges and Spurious Emission	$\leq 20\text{dBc}$	Pass	-
3.5	15.247(d)	Radiated Band Edges and Spurious Emission	15.209(a) & 15.247(d)	Pass	Under limit 4.28 dB at 7320.000 MHz
3.6	15.207	AC Conducted Emission	15.207(a)	Pass	Under limit 19.30 dB at 13.558 MHz
3.7	15.203 & 15.247(b)	Antenna Requirement	N/A	Pass	-



# 1 General Description

## 1.1 Applicant

**Sony Mobile Communications Inc.**

4-12-3 Higashi-shinagawa, Shinagawa-ku, Tokyo, 140-0002, Japan

## 1.2 Manufacturer

**Sony Mobile Communications Inc.**

4-12-3 Higashi-shinagawa, Shinagawa-ku, Tokyo, 140-0002, Japan

## 1.3 Product Feature of Equipment Under Test

Standards-related Product Specification	
Bluetooth Antenna Type / Gain	FPCB Pattern Antenna type with gain 0.06 dBi

EUT Information List			
HW Version	SW Version	S/N	Performed Test Item
A	v1.0.1	84C7EAF7316F	RF conducted measurement
		84C7EAF73159	Radiated Spurious Emission
		84C7EAF73152	Conducted Emission

Accessory List	
<b>Adapter</b>	Model No. : UCH20
	S/N : 1215W48600039
<b>Earphone</b>	Model No. : MH755
	S/N : 16482013D0B146C
<b>USB Cable</b>	Model No. : UCB20
	S/N : 1702A93700CBBA2

**Note:**

1. Above EUT list and accessory list used are electrically identical per declared by manufacturer.
2. Above the accessories list are used to exercise the EUT during test.
3. For other wireless features of this EUT, test report will be issued separately.

## 1.4 Modification of EUT

No modifications are made to the EUT during all test items.



### 1.5 Testing Location

Sporton Lab is accredited to ISO 17025 by Taiwan Accreditation Foundation (TAF code : 1190) and the FCC designation No. TW0007 under the FCC 2.948(e) by Mutual Recognition Agreement (MRA) in FCC Test.

<b>Test Site</b>	SPORTON INTERNATIONAL INC.	
<b>Test Site Location</b>	No. 52, Hwa Ya 1 <sup>st</sup> Rd., Hwa Ya Technology Park, Kwei-Shan District, Tao Yuan City, Taiwan, R.O.C. TEL: +886-3-327-3456 FAX: +886-3-328-4978	
<b>Test Site No.</b>	<b>Sporton Site No.</b>	
	TH05-HY	CO05-HY

**Note:** The test site complies with ANSI C63.4 2014 requirement.

<b>Test Site</b>	SPORTON INTERNATIONAL INC.	
<b>Test Site Location</b>	No.58, Aly. 75, Ln. 564, Wenhua 3rd Rd. Guishan Dist, Taoyuan City, Taiwan (R.O.C.) TEL: +886-3-327-0868 FAX: +886-3-327-0855	
<b>Test Site No.</b>	<b>Sporton Site No.</b>	
	03CH10-HY	

**Note:** The test site complies with ANSI C63.4 2014 requirement.

<b>Test Site</b>	SPORTON INTERNATIONAL INC.	
<b>Test Site Location</b>	No. 30-2, Dingfu Tsuen, Linkou District, New Taipei City, Taiwan, R.O.C. TEL: +886-3-327-0868 FAX: +886-3-327-0855	
<b>Test Site No.</b>	<b>Sporton Site No.</b>	
	OS03-LK	

**Note:** The test site complies with ANSI C63.4 2014 requirement



## **1.6 Applicable Standards**

According to the specifications of the manufacturer, the EUT must comply with the requirements of the following standards:

- ♦ FCC Part 15 Subpart C §15.247
- ♦ FCC KDB Publication No. 558074 D01 DTS Meas. Guidance v04
- ♦ ANSI C63.10-2013

### **Remark:**

1. All test items were verified and recorded according to the standards and without any deviation during the test.
2. This EUT has also been tested and complied with the requirements of FCC Part 15, Subpart B, recorded in a separate test report.



## 2 Test Configuration of Equipment Under Test

### 2.1 Carrier Frequency Channel

Frequency Band	Channel	Freq. (MHz)	Channel	Freq. (MHz)
2400-2483.5 MHz	0	2402	21	2444
	1	2404	22	2446
	2	2406	23	2448
	3	2408	24	2450
	4	2410	25	2452
	5	2412	26	2454
	6	2414	27	2456
	7	2416	28	2458
	8	2418	29	2460
	9	2420	30	2462
	10	2422	31	2464
	11	2424	32	2466
	12	2426	33	2468
	13	2428	34	2470
	14	2430	35	2472
	15	2432	36	2474
	16	2434	37	2476
	17	2436	38	2478
	18	2438	39	2480
	19	2440	-	-
20	2442	-	-	





## 2.2 Descriptions of Test Mode

The RF output power was recorded in the following table:

Channel	Frequency	Bluetooth – LE RF Output Power
		Data Rate / Modulation
		GFSK
		1Mbps
Ch00	2402MHz	2.89 dBm
Ch19	2440MHz	2.88 dBm
Ch39	2480MHz	2.46 dBm

- a. The EUT has been associated with peripherals and configuration operated in a manner tended to maximize its emission characteristics in a typical application. Frequency range investigated: conduction (150 kHz to 30 MHz), radiation (9 kHz to the 10th harmonic of the highest fundamental frequency or to 40 GHz, whichever is lower). Pre-scanned tests, X, Y, Z in three orthogonal panels to determine the final configuration (X plane as worst plane) from all possible combinations.
- b. AC power line Conducted Emission was tested under maximum output power.

## 2.3 Test Mode

The following summary table is showing all test modes to demonstrate in compliance with the standard.

Summary table of Test Cases	
Test Item	Data Rate / Modulation
	Bluetooth – LE / GFSK
Conducted TCs	Mode 1: Bluetooth Tx CH00_2402 MHz_1Mbps Mode 2: Bluetooth Tx CH19_2440 MHz_1Mbps Mode 3: Bluetooth Tx CH39_2480 MHz_1Mbps
Radiated TCs	Mode 1: Bluetooth Tx CH00_2402 MHz_1Mbps Mode 2: Bluetooth Tx CH19_2440 MHz_1Mbps Mode 3: Bluetooth Tx CH39_2480 MHz_1Mbps
AC Conducted Emission	Mode 1: Bluetooth Link + USB Cable (Charging from Adapter) + Battery + Earphone

## 2.4 Connection Diagram of Test System

<Bluetooth – LE Tx Mode>

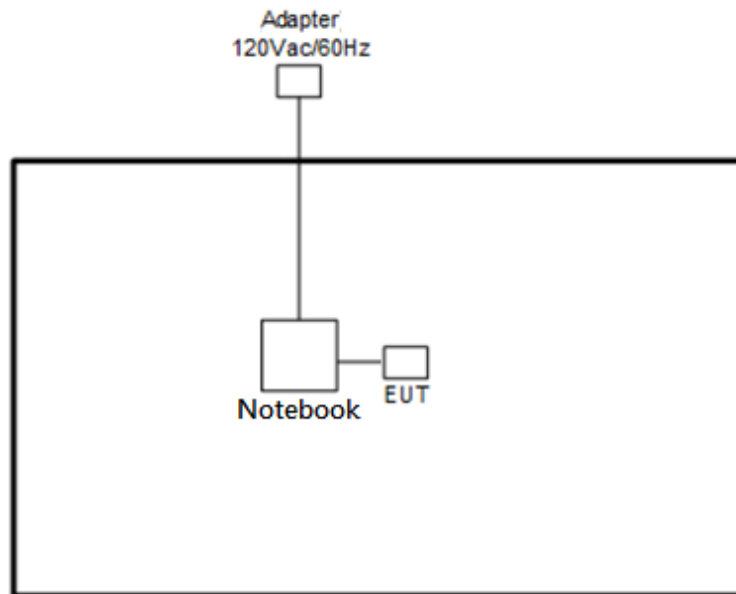

<AC Conducted Emission Mode>

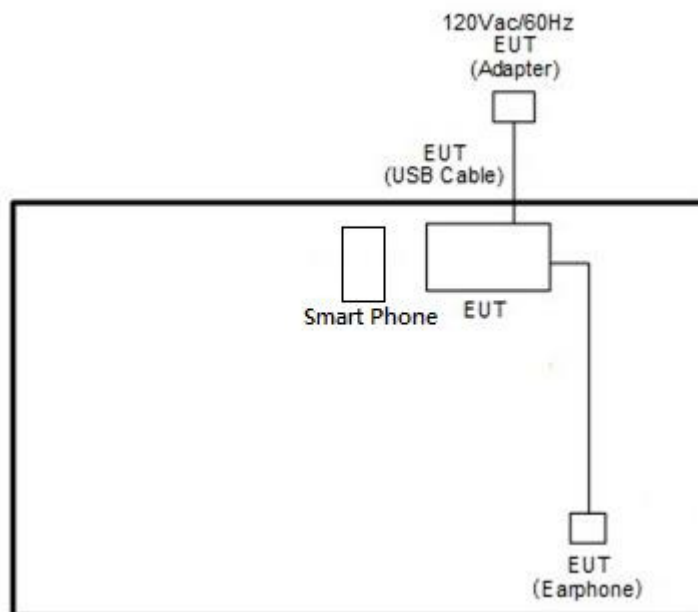



## 2.5 Support Unit used in test configuration and system

Item	Equipment	Trade Name	Model Name	FCC ID	Data Cable	Power Cord
1.	Smart Phone	Sony	-	PY7-84773W	N/A	N/A
2.	Notebook	DELL	Latitude E3340	FCC DoC/ Contains FCC ID: PD97260NGU	N/A	AC I/P: Unshielded, 1.2 m DC O/P: Shielded, 1.8 m

## 2.6 EUT Operation Test Setup

The RF test items, an engineering test program was provided and enabled to make EUT transmitting and receiving signals.

## 2.7 Measurement Results Explanation Example

For all conducted test items:

The offset level is set in the spectrum analyzer to compensate the RF cable loss and attenuator factor between EUT conducted output port and spectrum analyzer. With the offset compensation, the spectrum analyzer reading level is exactly the EUT RF output level.

Example :

The spectrum analyzer offset is derived from RF cable loss and attenuator factor.

*Offset = RF cable loss + attenuator factor.*

Following shows an offset computation example with cable loss 4.2 dB and 10dB attenuator.

$$\begin{aligned}
 \text{Offset(dB)} &= \text{RF cable loss(dB)} + \text{attenuator factor(dB)}. \\
 &= 4.2 + 10 = 14.2 \text{ (dB)}
 \end{aligned}$$

### 3 Test Result

#### 3.1 6dB and 99% Bandwidth Measurement

##### 3.1.1 Limit of 6dB and 99% Bandwidth

The minimum 6 dB bandwidth shall be at least 500 kHz.

##### 3.1.2 Measuring Instruments

The section 4.0 of List of Measuring Equipment of this test report is used for test.

##### 3.1.3 Test Procedures

1. The testing follows FCC KDB Publication No. 558074 D01 DTS Meas. Guidance v04.
2. The RF output of EUT was connected to the spectrum analyzer by RF cable and attenuator. The path loss was compensated to the results for each measurement.
3. Set to the maximum power setting and enable the EUT transmit continuously.
4. Make the measurement with the spectrum analyzer's resolution bandwidth (RBW) = 100 kHz. Set the Video bandwidth (VBW) = 300 kHz. In order to make an accurate measurement. The 6 dB bandwidth must be greater than 500 kHz.
5. For 99% Bandwidth Measurement, the spectrum analyzer's resolution bandwidth (RBW) is set 30kHz and set the Video bandwidth (VBW) = 100kHz.
6. Measure and record the results in the test report.

##### 3.1.4 Test Setup

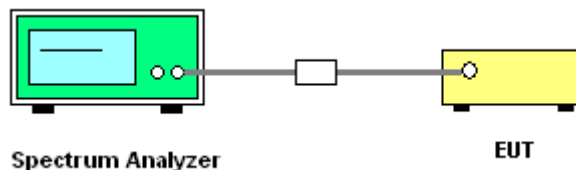

##### 3.1.5 Test Result of 6dB Bandwidth

Please refer to Appendix A.



### 6 dB Bandwidth Plot on Channel 00

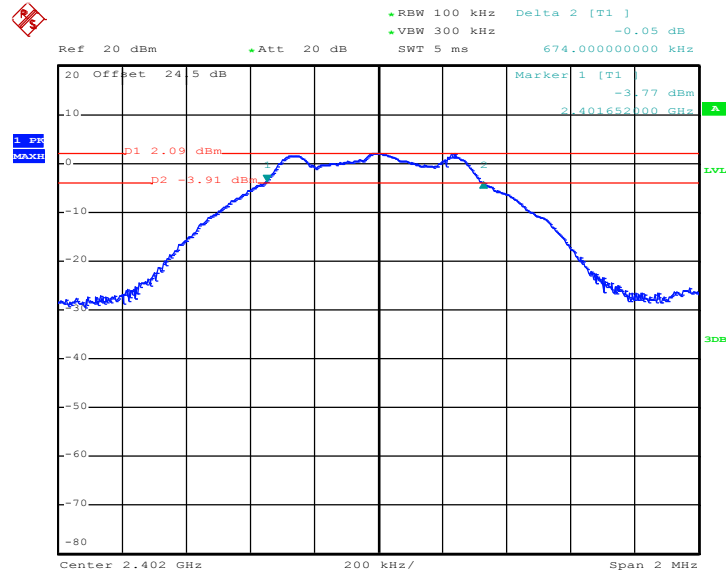

Date: 9.APR.2017 10:10:13

### 6 dB Bandwidth Plot on Channel 19

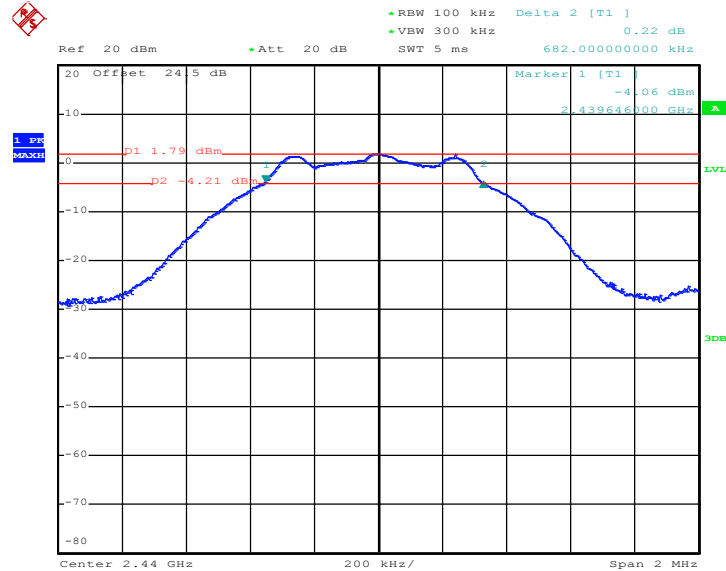

Date: 9.APR.2017 10:16:25



6 dB Bandwidth Plot on Channel 39

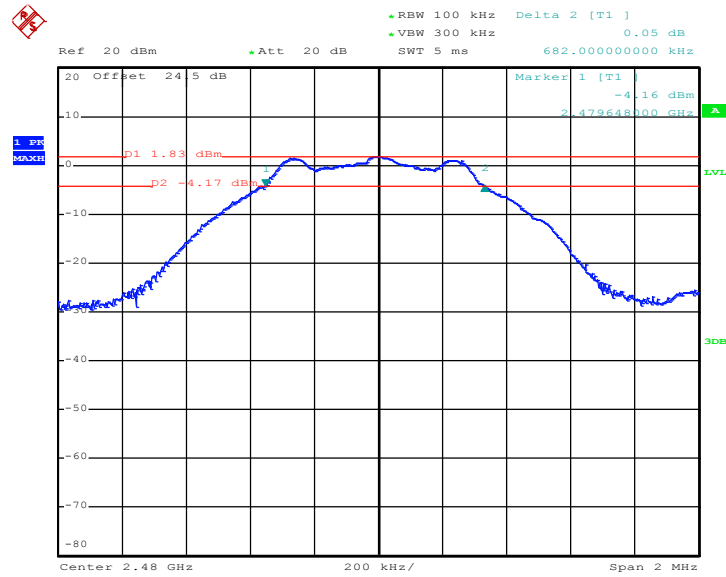

Date: 9.APR.2017 10:23:14



### 3.1.6 Test Result of 99% Occupied Bandwidth

Please refer to Appendix A.

99% Bandwidth Plot on Channel 00

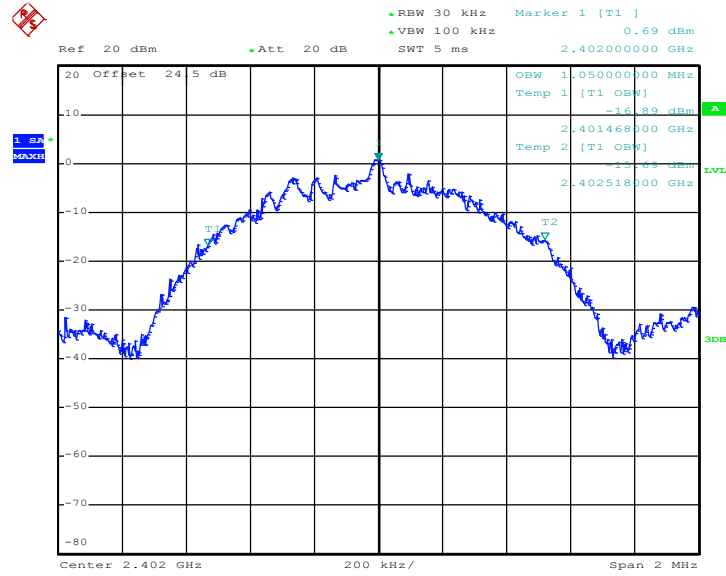

Date: 9.APR.2017 10:11:47



99% Occupied Bandwidth Plot on Channel 19

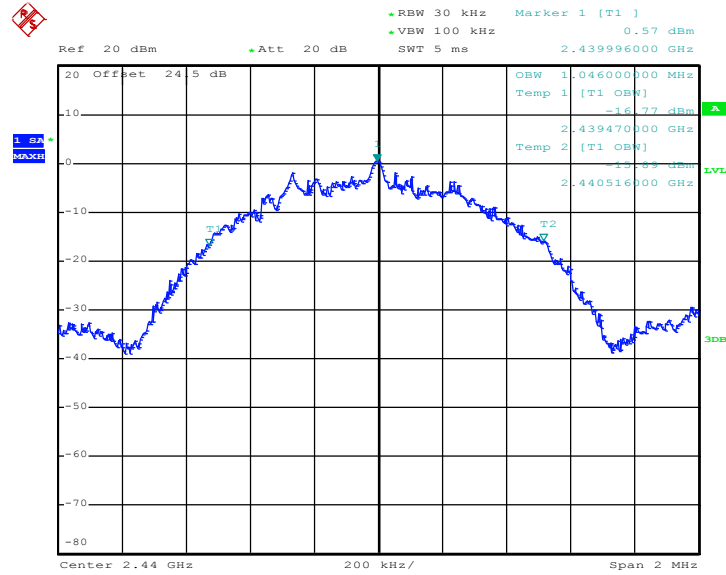

Date: 9.APR.2017 10:20:40

99% Occupied Bandwidth Plot on Channel 39

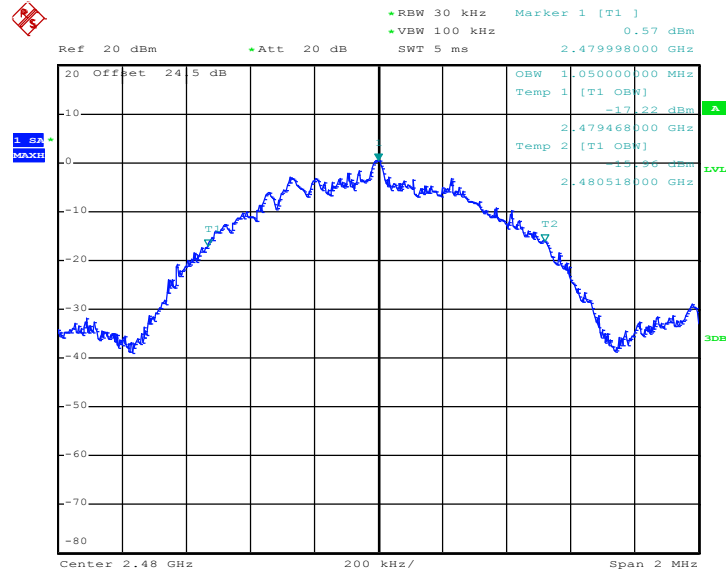

Date: 9.APR.2017 10:27:19

Note: The occupied channel bandwidth is maintained within the band of operation for all of the modulations.



## 3.2 Peak Output Power Measurement

### 3.2.1 Limit of Peak Output Power

For systems using digital modulation in the 2400-2483.5MHz, the limit for peak output power is 30dBm. If transmitting antenna of directional gain greater than 6dBi is used, the peak output power from the intentional radiator shall be reduced below the above stated value by the amount in dB that the directional gain of the antenna exceeds 6 dBi. In case of point-to-point operation, the limit has to be reduced by 1dB for every 3dB that the directional gain of the antenna exceeds 6dBi.

### 3.2.2 Measuring Instruments

The section 4.0 of List of Measuring Equipment of this test report is used for test.

### 3.2.3 Test Procedures

1. The testing follows the Measurement Procedure of FCC KDB No. 558074 DTS D01 Meas. Guidance v04 section 9.1.3 PKPM1 Peak power meter method.
2. The RF output of EUT was connected to the power meter by RF cable and attenuator. The path loss was compensated to the results for each measurement.
3. Set to the maximum power setting and enable the EUT transmit continuously.
4. Measure the conducted output power and record the results in the test report.

### 3.2.4 Test Setup

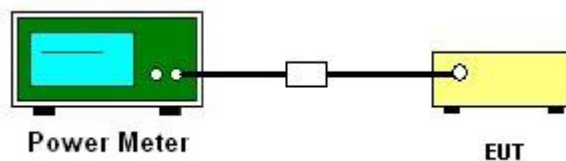

### 3.2.5 Test Result of Peak Output Power

Please refer to Appendix A.

### 3.3 Power Spectral Density Measurement

#### 3.3.1 Limit of Power Spectral Density

The peak power spectral density shall not be greater than 8dBm in any 3kHz band at any time interval of continuous transmission.

#### 3.3.2 Measuring Instruments

The section 4.0 of List of Measuring Equipment of this test report is used for test.

#### 3.3.3 Test Procedures

1. The testing follows Measurement Procedure 10.2 Method PKPSD of FCC KDB Publication No. 558074 D01 DTS Meas. Guidance v04
2. The RF output of EUT was connected to the spectrum analyzer by RF cable and attenuator. The path loss was compensated to the results for each measurement.
3. Set to the maximum power setting and enable the EUT transmit continuously.
4. Make the measurement with the spectrum analyzer's resolution bandwidth (RBW) = 3 kHz. Video bandwidth VBW = 10 kHz In order to make an accurate measurement, set the span to 1.5 times DTS Channel Bandwidth. (6dB BW)
5. Detector = peak, Sweep time = auto couple, Trace mode = max hold, Allow trace to fully stabilize. Use the peak marker function to determine the maximum power level.
6. Measure and record the results in the test report.
7. The Measured power density (dBm)/ 100kHz is a reference level and used as 20dBc down limit line for Conducted Band Edges and Conducted Spurious Emission.

#### 3.3.4 Test Setup

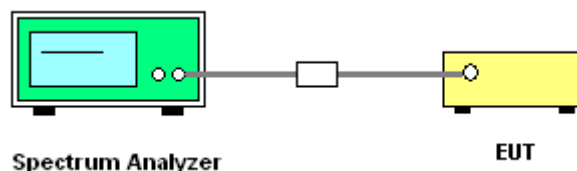

#### 3.3.5 Test Result of Power Spectral Density

Please refer to Appendix A.



### 3.3.6 Test Result of Power Spectral Density Plots (100kHz)

PSD 100kHz Plot on Channel 00

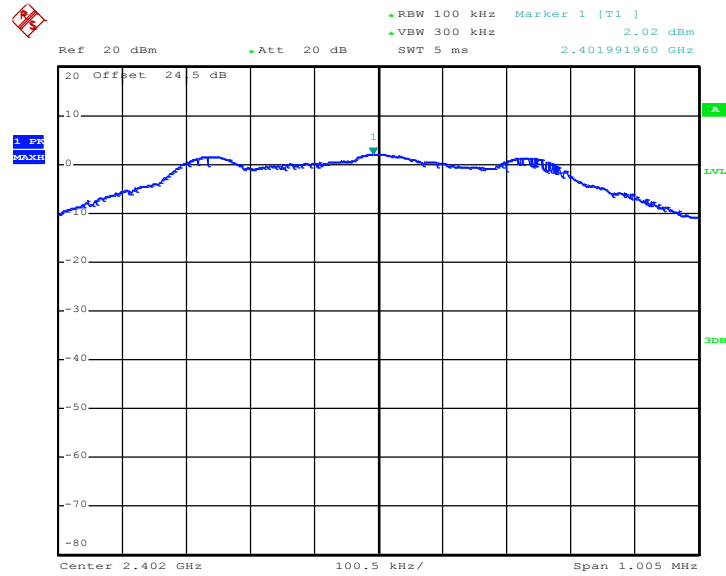

Date: 9.APR.2017 10:10:49

PSD 100kHz Plot on Channel 19

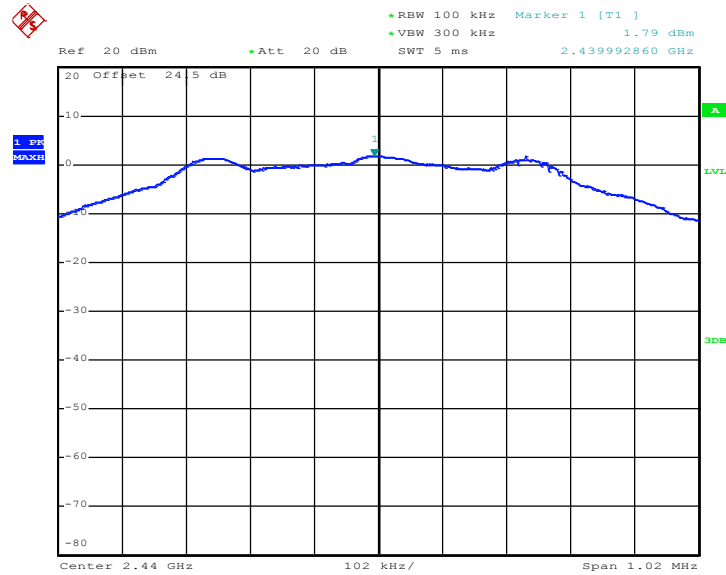

Date: 9.APR.2017 10:19:18



PSD 100kHz Plot on Channel 39

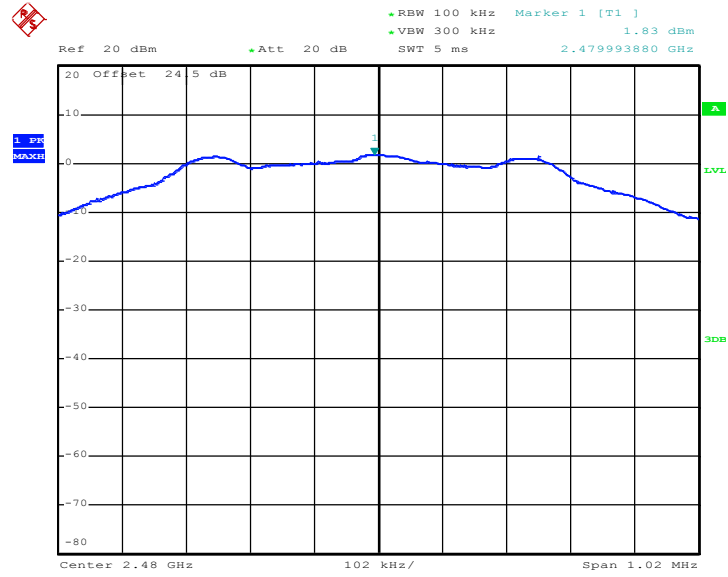

Date: 9.APR.2017 10:25:40



### 3.3.7 Test Result of Power Spectral Density Plots (3kHz)

PSD 3kHz Plot on Channel 00

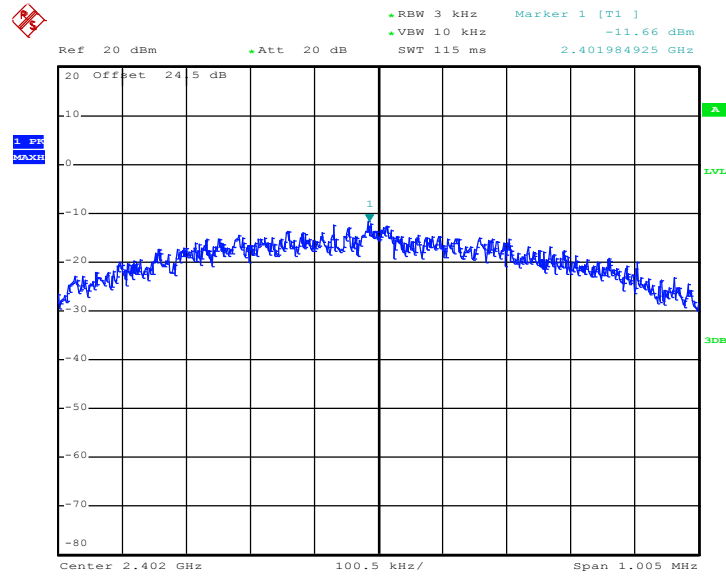

Date: 9.APR.2017 10:10:30

PSD 3kHz Plot on Channel 19

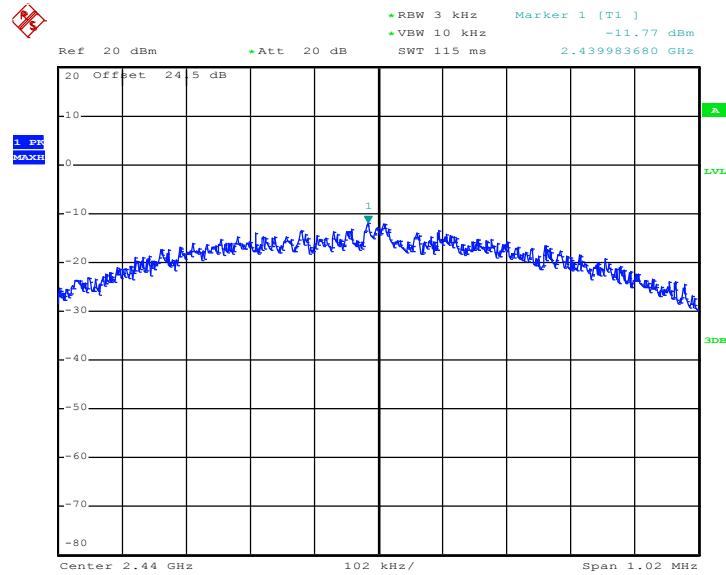

Date: 9.APR.2017 10:18:09



PSD 3kHz Plot on Channel 39

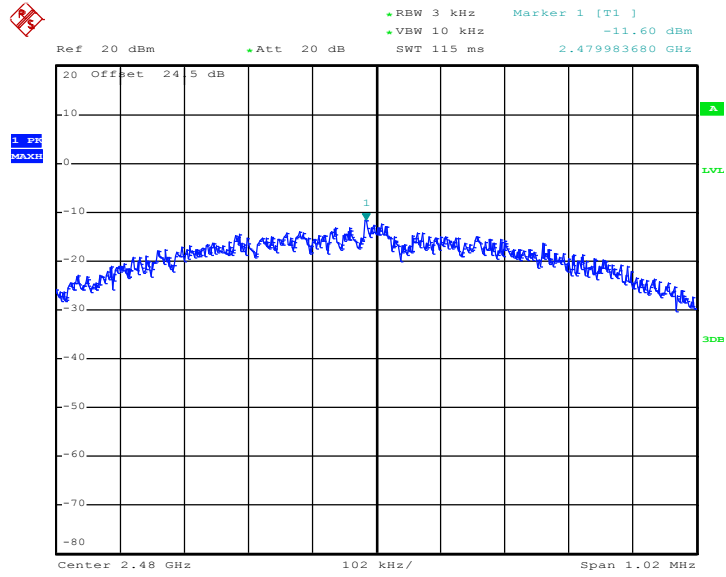

Date: 9.APR.2017 10:23:46

### 3.4 Conducted Band Edges and Spurious Emission Measurement

#### 3.4.1 Limit of Conducted Band Edges and Spurious Emission

All harmonics/spurious must be at least 20 dB down from the highest emission level within the authorized band.

#### 3.4.2 Measuring Instruments

The section 4.0 of List of Measuring Equipment of this test report is used for test.

#### 3.4.3 Test Procedure

1. The testing follows FCC KDB Publication No. 558074 D01 DTS Meas. Guidance v04.
2. The RF output of EUT was connected to the spectrum analyzer by RF cable and attenuator. The path loss was compensated to the results for each measurement.
3. Set to the maximum power setting and enable the EUT transmit continuously.
4. Set RBW = 100 kHz, VBW=300 kHz, Peak Detector. Unwanted Emissions measured in any 100 kHz bandwidth outside of the authorized frequency band shall be attenuated by at least 20 dB relative to the maximum in-band peak PSD level in 100 kHz when maximum peak conducted output power procedure is used. If the transmitter complies with the conducted power limits based on the use of RMS averaging over a time interval, the attenuation required under this paragraph shall be 30 dB instead of 20 dB.
5. Measure and record the results in the test report.
6. The RF fundamental frequency should be excluded against the limit line in the operating frequency band.

#### 3.4.4 Test Setup





### 3.4.5 Test Result of Conducted Band Edges Plots

#### Low Band Edge Plot on Channel 00

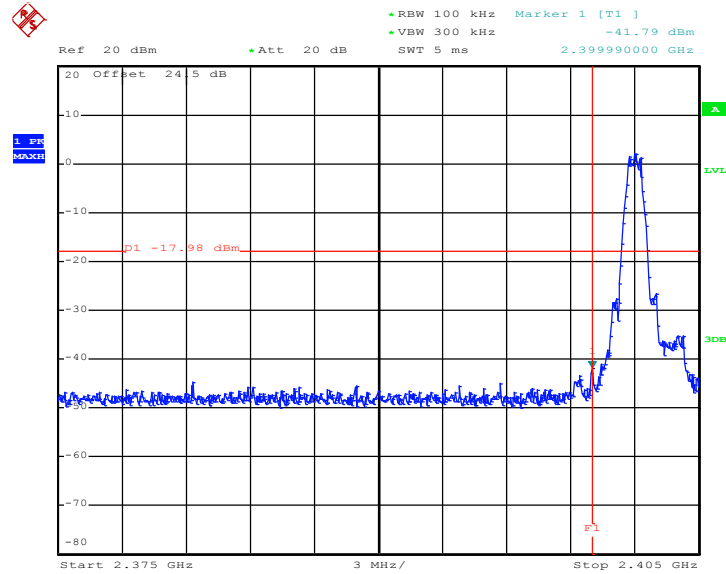

Date: 9.APR.2017 10:11:04

#### High Band Edge Plot on Channel 39

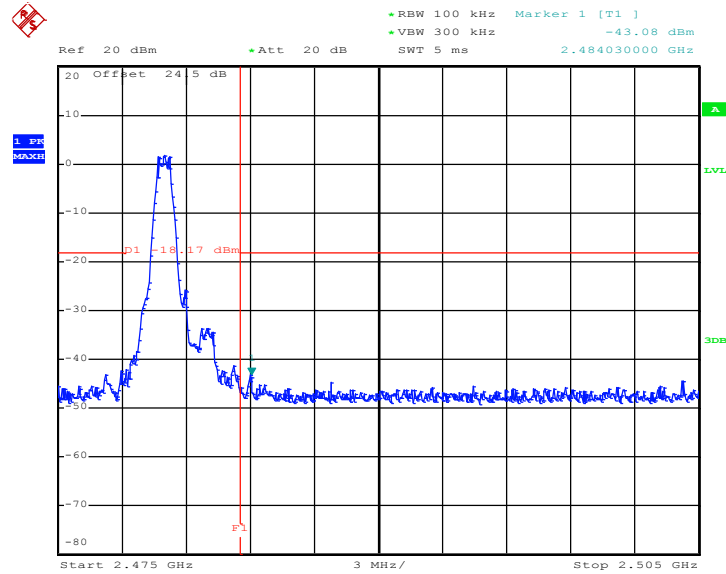

Date: 9.APR.2017 10:26:23





### 3.4.6 Test Result of Conducted Spurious Emission Plots

#### Conducted Spurious Emission Plot on Bluetooth LE 1Mbps GFSK Channel 00

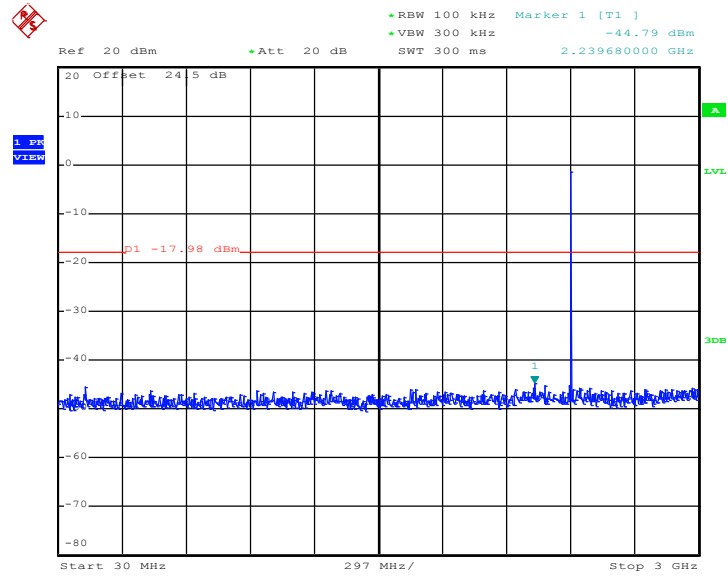

Date: 9.APR.2017 10:11:16

#### Conducted Spurious Emission Plot on Bluetooth LE 1Mbps GFSK Channel 00

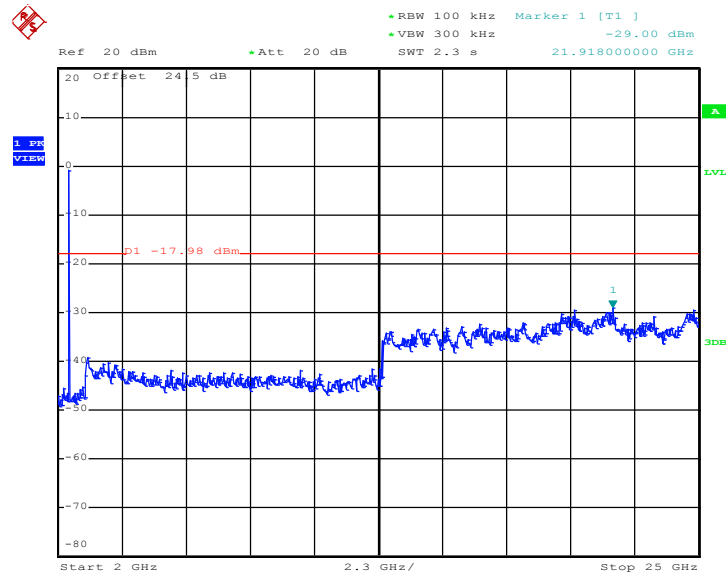

Date: 9.APR.2017 10:11:24



### Conducted Spurious Emission Plot on Bluetooth LE 1Mbps GFSK Channel 19

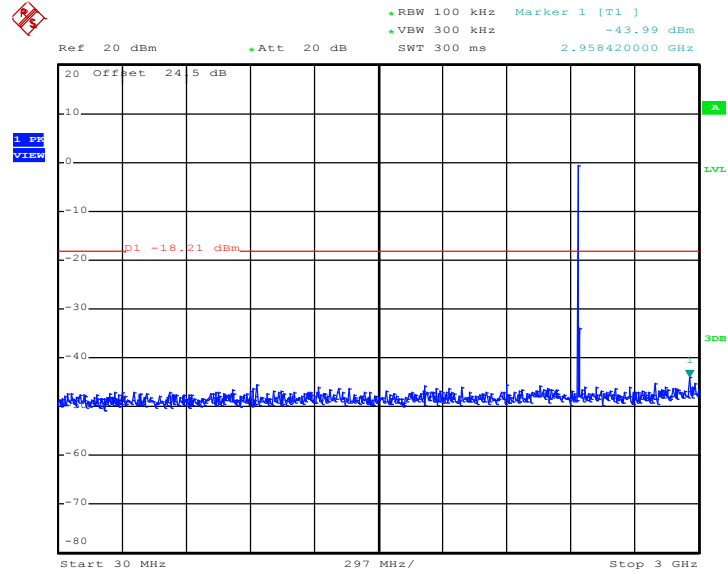

Date: 9.APR.2017 10:19:57

### Conducted Spurious Emission Plot on Bluetooth LE 1Mbps GFSK Channel 19

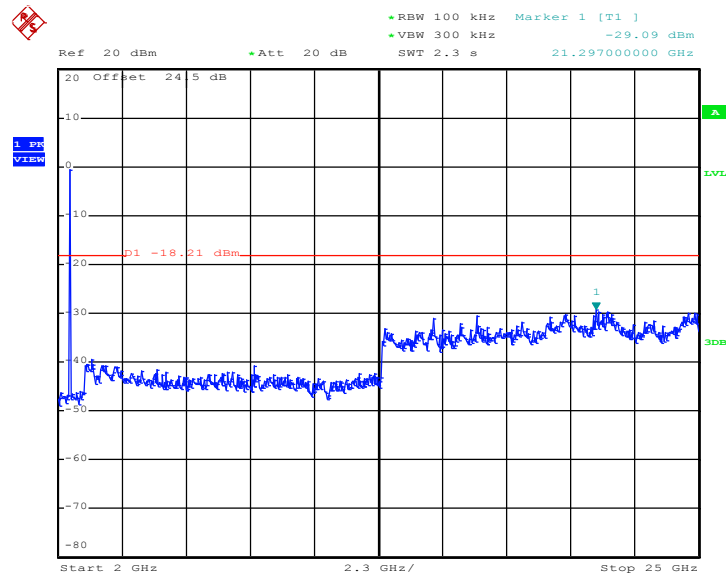

Date: 9.APR.2017 10:20:06



### Conducted Spurious Emission Plot on Bluetooth LE 1Mbps GFSK Channel 39

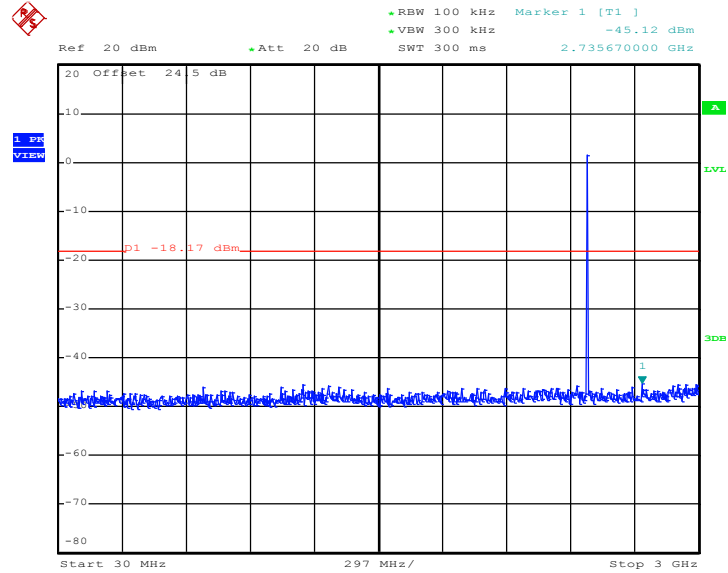

Date: 9.APR.2017 10:26:37

### Conducted Spurious Emission Plot on Bluetooth LE 1Mbps GFSK Channel 39

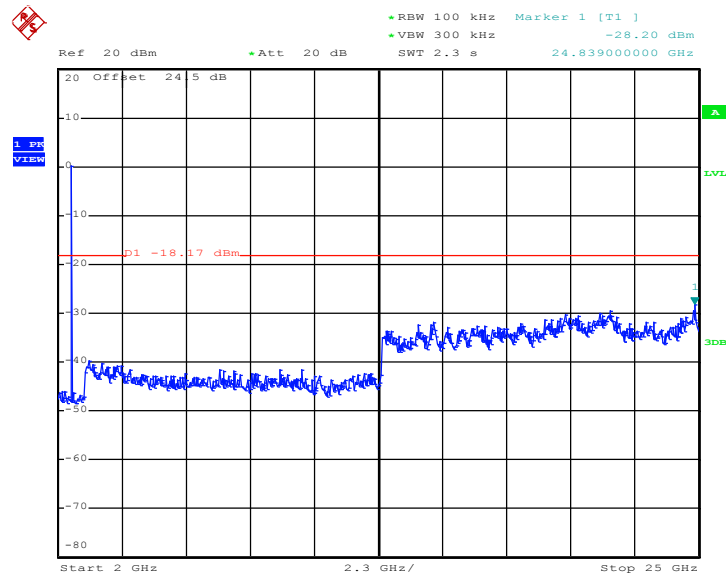

Date: 9.APR.2017 10:26:46



### 3.5 Radiated Band Edges and Spurious Emission Measurement

#### 3.5.1 Limit of Radiated Band Edges and Spurious Emission

In any 100 kHz bandwidth outside the intentional radiator frequency band, all harmonics/spurious must be at least 20 dB below the highest emission level within the authorized band. If the output power of this device was measured by spectrum analyzer, the attenuation under this paragraph shall be 30 dB instead of 20 dB. In addition, radiated emissions which fall in the restricted bands must also comply with the limits as below.

Frequency (MHz)	Field Strength (microvolts/meter)	Measurement Distance (meters)
0.009 – 0.490	2400/F(kHz)	300
0.490 – 1.705	24000/F(kHz)	30
1.705 – 30.0	30	30
30 – 88	100	3
88 – 216	150	3
216 - 960	200	3
Above 960	500	3

#### 3.5.2 Measuring Instruments

The section 4.0 of List of Measuring Equipment of this test report is used for test.



### **3.5.3 Test Procedures**

1. The testing follows FCC KDB Publication No. 558074 D01 DTS Meas. Guidance v04.
2. The EUT was arranged to its worst case and then tune the antenna tower (from 1 m to 4 m) and turntable (from 0 degree to 360 degrees) to find the maximum reading. A pre-amp and a high pass filter are used for the test in order to get better signal level.
3. The EUT was placed on a turntable with 0.8 meter for frequency below 1GHz and 1.5 meter for frequency above 1GHz respectively above ground.
4. The EUT was set 3 meters from the interference receiving antenna, which was mounted on the top of a variable height antenna tower.
5. Corrected Reading: Antenna Factor + Cable Loss + Read Level - Preamp Factor = Level
6. For measurement below 1GHz, If the emission level of the EUT measured by the peak detector is 3 dB lower than the applicable limit, the peak emission level will be reported. Otherwise, the emission measurement will be repeated using the quasi-peak detector and reported.
7. Use the following spectrum analyzer settings:
  - (1) Span shall wide enough to fully capture the emission being measured;
  - (2) Set RBW=100 kHz for  $f < 1$  GHz; VBW  $\geq$  RBW; Sweep = auto; Detector function = peak; Trace = max hold;
  - (3) Set RBW = 1 MHz, VBW= 3MHz for  $f \geq 1$  GHz for peak measurement.  
For average measurement:
    - VBW = 10 Hz, when duty cycle is no less than 98 percent.
    - VBW  $\geq 1/T$ , when duty cycle is less than 98 percent where T is the minimum transmission duration over which the transmitter is on and is transmitting at its maximum power control level for the tested mode of operation.

### 3.5.4 Test Setup

For radiated emissions below 30MHz

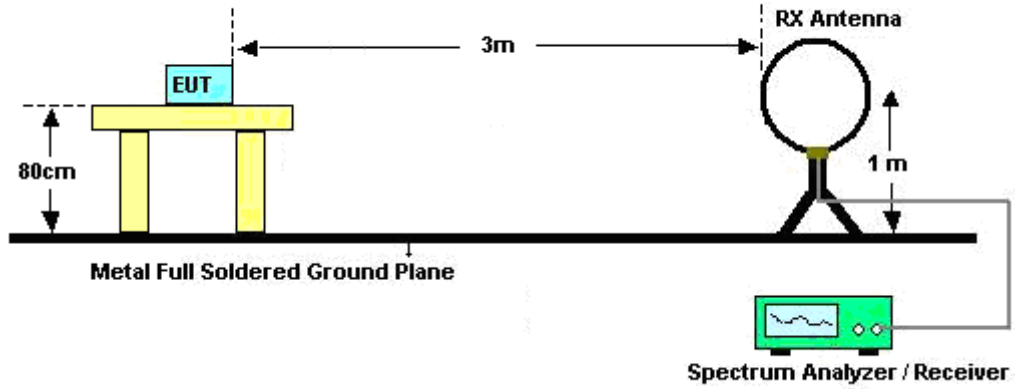

For radiated emissions from 30MHz to 1GHz

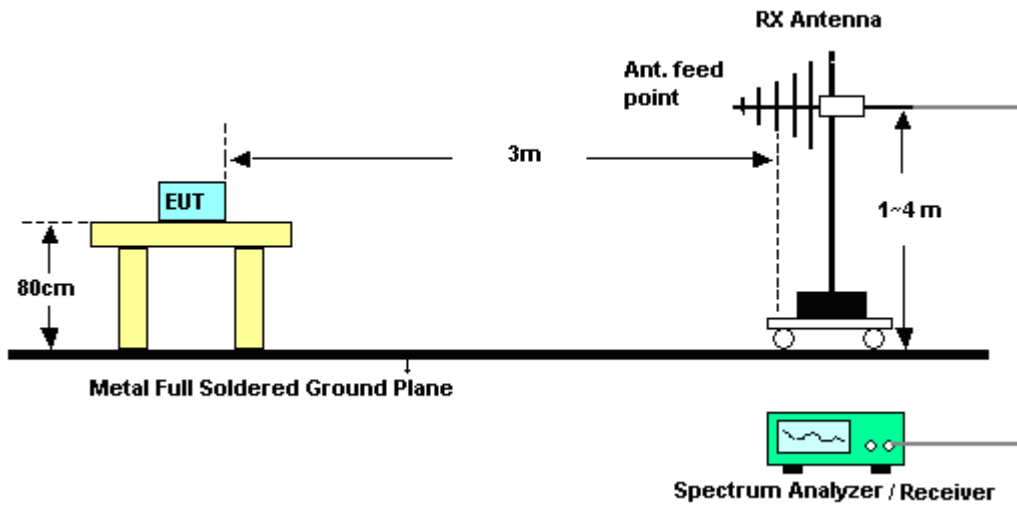

For radiated emissions above 1GHz

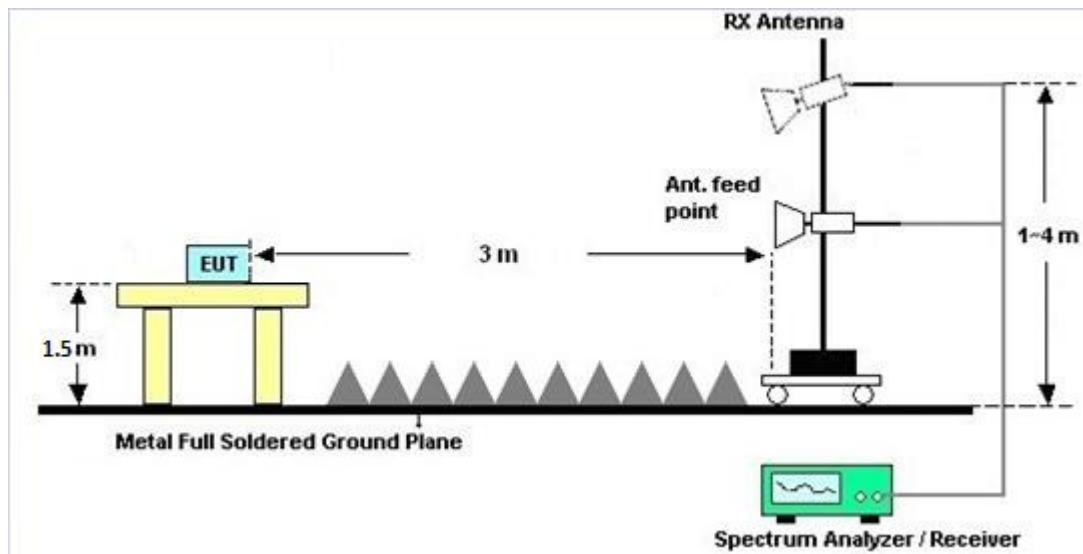

### 3.5.5 Test Results of Radiated Spurious Emissions (9 kHz ~ 30 MHz)

Please refer to Appendix D.

### 3.5.6 Test Result of Radiated Spurious at Band Edges

Please refer to Appendix C and D.

### 3.5.7 Duty Cycle

Please refer to Appendix E.

### 3.5.8 Test Result of Radiated Spurious Emission (30MHz ~ 10th Harmonic)

Please refer to Appendix C and D.



### 3.6 AC Conducted Emission Measurement

#### 3.6.1 Limit of AC Conducted Emission

For equipment that is designed to be connected to the public utility (AC) power line, the radio frequency voltage that is conducted back onto the AC power line on any frequency or frequencies within the band 150 kHz to 30 MHz shall not exceed the limits in the following table.

Frequency of emission (MHz)	Conducted limit (dB $\mu$ V)	
	Quasi-peak	Average
0.15-0.5	66 to 56*	56 to 46*
0.5-5	56	46
5-30	60	50

\*Decreases with the logarithm of the frequency.

#### 3.6.2 Measuring Instruments

The section 4.0 of List of Measuring Equipment of this test report is used for test.

#### 3.6.3 Test Procedures

1. The EUT was placed 0.4 meter from the conducting wall of the shielding room was kept at least 80 centimeters from any other grounded conducting surface.
2. Connect EUT to the power mains through a line impedance stabilization network (LISN).
3. All the support units are connecting to the other LISN.
4. The LISN provides 50 ohm coupling impedance for the measuring instrument.
5. The FCC states that a 50 ohm, 50 microhenry LISN should be used.
6. Both sides of AC line were checked for maximum conducted interference.
7. The frequency range from 150 kHz to 30 MHz was searched.
8. Set the test-receiver system to Peak Detect Function and specified bandwidth (IF Bandwidth = 9kHz) with Maximum Hold Mode. Then measurement is also conducted by Average Detector and Quasi-Peak Detector Function respectively.



### 3.6.4 Test Setup

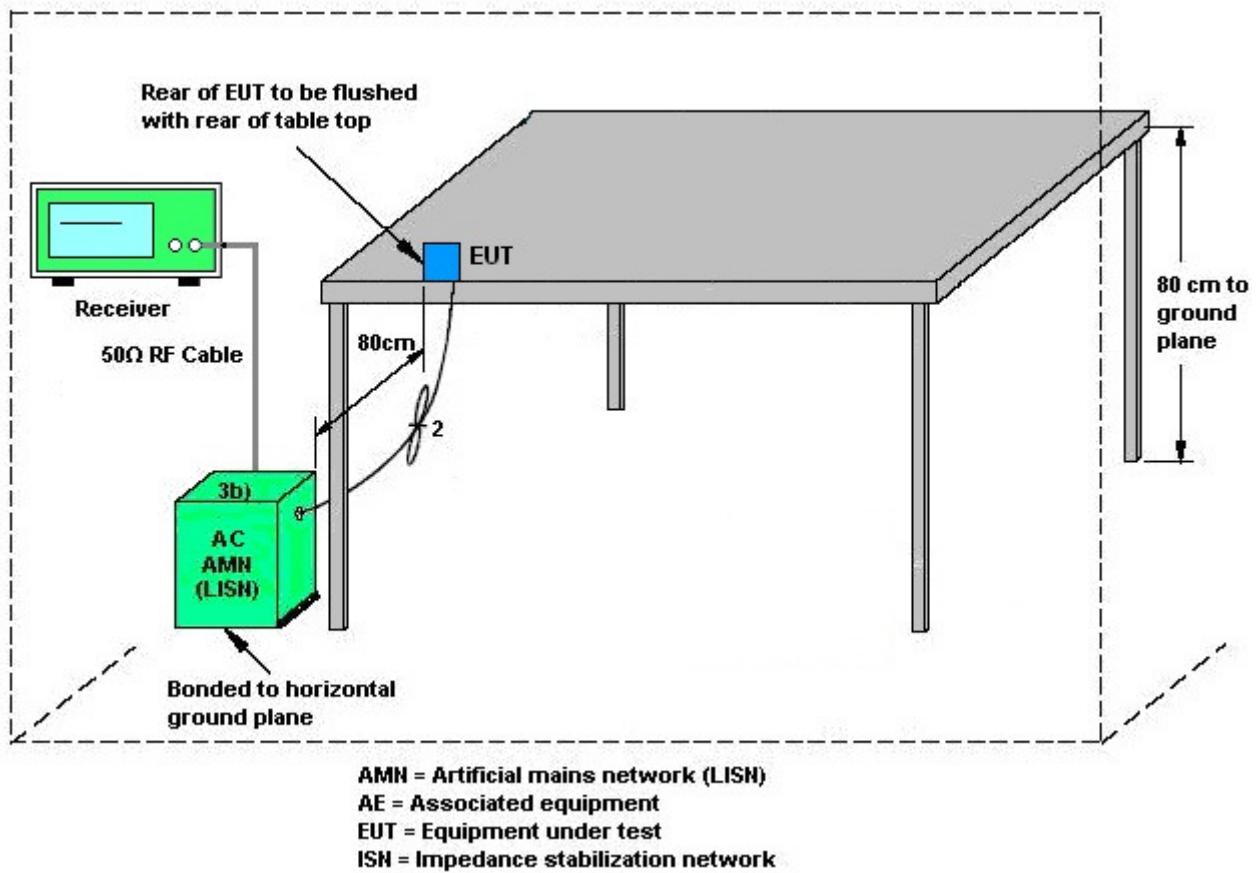

### 3.6.5 Test Result of AC Conducted Emission

Please refer to Appendix B.



## **3.7 Antenna Requirements**

### **3.7.1 Standard Applicable**

If directional gain of transmitting antennas is greater than 6dBi, the power shall be reduced by the same level in dB comparing to gain minus 6dBi. The use of a permanently attached antenna or of an antenna that uses a unique coupling to the intentional radiator shall be considered sufficient to comply with the rule.

### **3.7.2 Antenna Anti-Replacement Construction**

An embedded-in antenna design is used.

### **3.7.3 Antenna Gain**

The antenna peak gain of EUT is less than 6 dBi. Therefore, it is not necessary to reduce maximum peak output power limit.



## 4 List of Measuring Equipment

Instrument	Manufacturer	Model No.	Serial No.	Characteristics	Calibration Date	Test Date	Due Date	Remark
Power Meter	Agilent	E4416A	GB412923 44	300MHz~40GHz	Dec. 26, 2016	Apr. 05, 2017 ~ Apr. 09, 2017	Dec. 25, 2017	Conducted (TH05-HY)
Power Sensor	Agilent	E9327A	US404415 48	300MHz~40GHz	Dec. 26, 2016	Apr. 05, 2017 ~ Apr. 09, 2017	Dec. 25, 2017	Conducted (TH05-HY)
Spectrum Analyzer	Rohde & Schwarz	FSP40	100055	9kHz-40GHz	Jul. 17, 2016	Apr. 05, 2017 ~ Apr. 09, 2017	Jul. 16, 2017	Conducted (TH05-HY)
Hygrometer	Testo	608-H2	41410069	N/A	Aug. 28, 2016	Apr. 05, 2017 ~ Apr. 09, 2017	Aug. 27, 2017	Conducted (TH05-HY)
RF Cable	HUBER + SUHNER	SUCOFLEX 104	MY842095 21	1GHz~26GHz	Dec. 02, 2016	Apr. 05, 2017 ~ Apr. 09, 2017	Dec. 01, 2017	Conducted (TH05-HY)
AC Power Source	ChainTek	APC-1000W	N/A	N/A	N/A	Apr. 06, 2017	N/A	Conduction (CO05-HY)
EMI Test Receiver	Rohde & Schwarz	ESCI 7	100724	9kHz~7GHz	Aug. 30, 2016	Apr. 06, 2017	Aug. 29, 2017	Conduction (CO05-HY)
Hygrometer	Testo	608-H1	34913912	N/A	Apr. 19, 2016	Apr. 06, 2017	Apr. 18, 2017	Conduction (CO05-HY)
LISN	Rohde & Schwarz	ENV216	100080	9kHz~30MHz	Nov. 29, 2016	Apr. 06, 2017	Nov. 28, 2017	Conduction (CO05-HY)
LF Cable	HUBER + SUHNER	RG-214/U	LF01	N/A	Jan. 05, 2017	Apr. 06, 2017	Jan. 04, 2018	Conduction (CO05-HY)
Test Software	N/A	EMC32	8.40.0	N/A	N/A	Apr. 06, 2017	N/A	Conduction (CO05-HY)
Loop Antenna	Rohde & Schwarz	HFH2-Z2	100315	9 kHz~30 MHz	Sep. 02, 2015	Apr. 06, 2017~ Apr. 18, 2017	Sep. 01, 2017	Radiation (03CH10-HY)
Bilog Antenna	TESEQ	CBL 6111D&00800 N1D01N-06	35413&02	30MHz~1GHz	Jan. 07, 2017	Apr. 06, 2017~ Apr. 18, 2017	Jan. 06, 2018	Radiation (03CH10-HY)
Horn Antenna	SCHWARZBE CK	BBHA 9120 D	9120D-132 5	1GHz ~ 18GHz	Sep. 30, 2016	Apr. 06, 2017~ Apr. 18, 2017	Sep. 29, 2017	Radiation (03CH10-HY)
SHF-EHF Horn Antenna	SCHWARZBE CK	BBHA 9170	BBHA9170 584	18GHz- 40GHz	Nov. 08, 2016	Apr. 06, 2017~ Apr. 18, 2017	Nov. 07, 2017	Radiation (03CH10-HY)
Spectrum Analyzer	Keysight	N9010A	MY542004 85	10Hz ~ 44GHz	Oct. 17, 2016	Apr. 06, 2017~ Apr. 18, 2017	Oct. 16, 2017	Radiation (03CH10-HY)
EMI Test Receiver	Agilent	N9038A (MXE)	MY532900 53	20Hz to 26.5GHz	Jan. 12, 2017	Apr. 06, 2017~ Apr. 18, 2017	Jan. 11, 2018	Radiation (03CH10-HY)
Amplifier	SONOMA	310N	187311	9kHz~1GHz	Oct. 26, 2016	Apr. 06, 2017~ Apr. 18, 2017	Oct. 25, 2017	Radiation (03CH10-HY)
Preamplifier	Keysight	83017A	MY532700 78	1GHz~26.5GHz	Oct. 26, 2016	Apr. 06, 2017~ Apr. 18, 2017	Oct. 25, 2017	Radiation (03CH10-HY)
Preamplifier	MITEQ	AMF-7D-0010 1800-30-10P	1815698	1GHz~18GHz	Dec. 01, 2016	Apr. 06, 2017~ Apr. 18, 2017	Nov. 30, 2017	Radiation (03CH10-HY)
Preamplifier	MITEQ	JS44-180040 00-33-8P	1840917	18GHz ~ 40GHz	Jun. 14, 2016	Apr. 06, 2017~ Apr. 18, 2017	Jun. 13, 2017	Radiation (03CH10-HY)



Instrument	Manufacturer	Model No.	Serial No.	Characteristics	Calibration Date	Test Date	Due Date	Remark
Hygrometer	TECEP	DTM-303B	TP140320	N/A	Nov. 14, 2016	Apr. 06, 2017~ Apr. 18, 2017	Nov. 13, 2017	Radiation (03CH10-HY)
RF Cable	HUBER + SUHNER	SUCOFLEX 104	MY249564 MY249524 MY283184	25GHz~40GHz	Sep. 30, 2016	Apr. 06, 2017~ Apr. 18, 2017	Sep. 29, 2017	Radiation (03CH10-HY)
RF Cable	HUBER + SUHNER	SUCOFLEX 104	MY249564 MY249524 MY283184	30MHz~1GHz	Sep. 30, 2016	Apr. 06, 2017~ Apr. 18, 2017	Sep. 29, 2017	Radiation (03CH10-HY)
RF Cable	HUBER + SUHNER	SUCOFLEX 104	MY249564 MY249524 MY283184	1GHz~25GHz	Sep. 30, 2016	Apr. 06, 2017~ Apr. 18, 2017	Sep. 29, 2017	Radiation (03CH10-HY)
Controller	EMEC	EM 1000	N/A	Control Turn table & Ant Mast	N/A	Apr. 06, 2017~ Apr. 18, 2017	N/A	Radiation (03CH10-HY)
Antenna Mast	EMEC	AM-BS-4500- B	N/A	1~4m	N/A	Apr. 06, 2017~ Apr. 18, 2017	N/A	Radiation (03CH10-HY)
Turn Table	EMEC	TT 2200	N/A	0~360 Degree	N/A	Apr. 06, 2017~ Apr. 18, 2017	N/A	Radiation (03CH10-HY)
Test Software	Audix	E3	6.2009-8-2 4	N/A	N/A	Apr. 06, 2017~ Apr. 18, 2017	N/A	Radiation (03CH10-HY)
Filter	Wainwright	WLKS1200-1 2SS	SN2	1.2G Low Pass	Sep. 19, 2016	Apr. 06, 2017~ Apr. 18, 2017	Sep. 18, 2017	Radiation (03CH10-HY)
Filter	Wainwright	H3G018G1	SN477221	3.0 G High Pass	N/A	Apr. 06, 2017~ Apr. 18, 2017	N/A	Radiation (03CH10-HY)
Amplifier	HP	8447D	2944A090 68	0.1MHz ~ 1.3GHz	Dec. 12, 2016	Apr. 18, 2017	Dec. 11, 2017	Radiation (OS03-LK)
Spectrum Analyzer	R&S	FSP 7	100641	9 kHz ~ 7 GHz	Jun. 23, 2016	Apr. 18, 2017	Jun. 22, 2017	Radiation (OS03-LK)
Loop Antenna	Rohde & Schwarz	HFH2-Z2	100315	9 kHz~30 MHz	Sep. 02, 2015	Apr. 18, 2017	Sep. 01, 2017	Radiation (OS03-LK)
Test Receiver	R&S	ESCS 30	836858/02 4	9 kHz ~ 2.75 GHz	Jun. 24, 2016	Apr. 18, 2017	Jun. 23, 2017	Radiation (OS03-LK)
Bilog Antenna with 5dB Attenuator	TESEQ & WOKEN	CBL6112D & 00800N1D01 N-05	25236 & 007	30 MHz ~ 1 GHz	Jul. 30, 2016	Apr. 18, 2017	Jul. 29, 2017	Radiation (OS03-LK)
Turn Table	EMCO	2080	9711-2021	0 ~ 360 degree	NCR	Apr. 18, 2017	NCR	Radiation (OS03-LK)
Antenna Mast	EMCO	2075	9711-2115	1 m ~ 4 m	NCR	Apr. 18, 2017	NCR	Radiation (OS03-LK)
Test Software	Audix	E3	4	N/A	N/A	Apr. 18, 2017	N/A	Radiation (OS03-LK)



## 5 Uncertainty of Evaluation

### Uncertainty of Conducted Emission Measurement (150 kHz ~ 30 MHz)

Measuring Uncertainty for a Level of Confidence of 95% ( $U = 2Uc(y)$ )	2.70
---	------

<03CH10-HY>

### Uncertainty of Radiated Emission Measurement (30 MHz ~ 1000 MHz)

Measuring Uncertainty for a Level of Confidence of 95% ( $U = 2Uc(y)$ )	5.60
---	------

### Uncertainty of Radiated Emission Measurement (1000 MHz ~ 18000 MHz)

Measuring Uncertainty for a Level of Confidence of 95% ( $U = 2Uc(y)$ )	5.90
---	------

### Uncertainty of Radiated Emission Measurement (18000 MHz ~ 40000 MHz)

Measuring Uncertainty for a Level of Confidence of 95% ( $U = 2Uc(y)$ )	5.20
---	------

<OS03-LK>

### Uncertainty of Radiated Emission Measurement (30 MHz ~ 1000 MHz)

Measuring Uncertainty for a Level of Confidence of 95% ( $U = 2Uc(y)$ )	4.10
---	------



## **Appendix A. Conducted Test Results**

**Bluetooth Low Energy**

Test Engineer:	Allen Lin / Aking Chang	Temperature:	21~25	°C
Test Date:	2017/04/05 ~ 2017/04/09	Relative Humidity:	51~54	%

**TEST RESULTS DATA**  
**6dB and 99% Occupied Bandwidth**

Mod.	Data Rate	NTX	CH.	Freq. (MHz)	99% Occupied BW (MHz)	6dB BW (MHz)	6dB BW Limit (MHz)	Pass/Fail
BLE	1Mbps	1	0	2402	1.050	0.674	0.50	Pass
BLE	1Mbps	1	19	2440	1.046	0.682	0.50	Pass
BLE	1Mbps	1	39	2480	1.050	0.682	0.50	Pass

**TEST RESULTS DATA**  
**Peak Power Table**

Mod.	Data Rate	NTX	CH.	Freq. (MHz)	Peak Conducted Power (dBm)	Conducted Power Limit (dBm)	DG (dBi)	EIRP Power (dBm)	EIRP Power Limit (dBm)	Pass /Fail
BLE	1Mbps	1	0	2402	2.89	30.00	0.06	2.95	36.00	Pass
BLE	1Mbps	1	19	2440	2.88	30.00	0.06	2.94	36.00	Pass
BLE	1Mbps	1	39	2480	2.46	30.00	0.06	2.52	36.00	Pass

**TEST RESULTS DATA**  
**Average Power Table**  
**(Reporting Only)**

Mod.	Data Rate	NTX	CH.	Freq. (MHz)	Duty Factor (dB)	Average Conducted Power (dBm)
BLE	1Mbps	1	0	2402	1.97	2.02
BLE	1Mbps	1	19	2440	1.97	2.16
BLE	1Mbps	1	39	2480	1.97	1.78

**TEST RESULTS DATA**  
**Peak Power Density**

Mod.	Data Rate	NTX	CH.	Freq. (MHz)	Peak PSD (dBm /100kHz)	Peak PSD (dBm /3kHz)	DG (dBi)	Peak PSD Limit (dBm /3kHz)	Pass/Fail
BLE	1Mbps	1	0	2402	2.02	-11.66	0.06	8.00	Pass
BLE	1Mbps	1	19	2440	1.79	-11.77	0.06	8.00	Pass
BLE	1Mbps	1	39	2480	1.83	-11.60	0.06	8.00	Pass

Note: PSD (dBm/ 100kHz) is a reference level used for Conducted Band Edges and Conducted Spurious Emission 20dBc limit.



## Appendix B. AC Conducted Emission Test Results

Test Engineer :	Kai-Chun Chu	Temperature :	23~24°C
		Relative Humidity :	52~53%



# EUT Information

Report NO : 730107  
 Test Mode : Mode 1  
 Test Voltage : 120Vac/60Hz  
 Phase : Line

ENV216 Auto Test FCC Power Bar - L

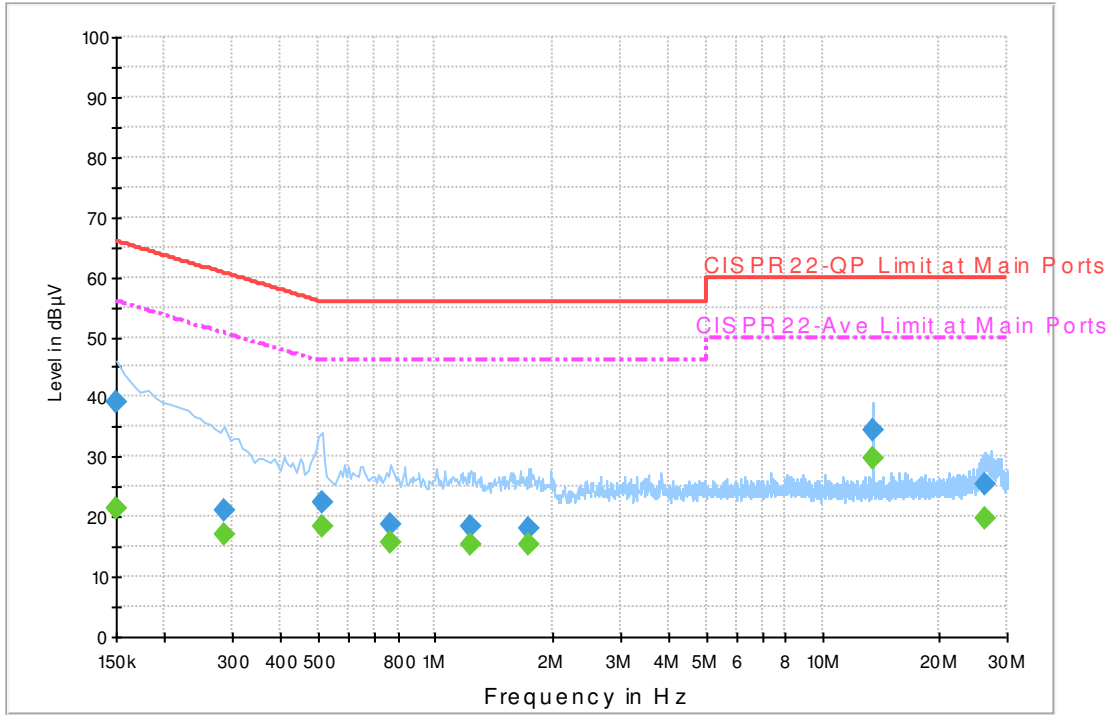

## Final Result 1

Frequency (MHz)	QuasiPeak (dBµV)	Filter	Line	Corr. (dB)	Margin (dB)	Limit (dBµV)
0.150000	39.0	Off	L1	19.6	27.0	66.0
0.286000	21.0	Off	L1	19.6	39.6	60.6
0.510000	22.5	Off	L1	19.6	33.5	56.0
0.766000	18.7	Off	L1	19.6	37.3	56.0
1.238000	18.4	Off	L1	19.6	37.6	56.0
1.750000	18.2	Off	L1	19.6	37.8	56.0
13.558000	34.3	Off	L1	20.2	25.7	60.0
26.390000	25.5	Off	L1	20.9	34.5	60.0

## Final Result 2

Frequency (MHz)	Average (dBµV)	Filter	Line	Corr. (dB)	Margin (dB)	Limit (dBµV)
0.150000	21.4	Off	L1	19.6	34.6	56.0
0.286000	17.0	Off	L1	19.6	33.6	50.6
0.510000	18.5	Off	L1	19.6	27.5	46.0
0.766000	15.6	Off	L1	19.6	30.4	46.0
1.238000	15.3	Off	L1	19.6	30.7	46.0
1.750000	15.4	Off	L1	19.6	30.6	46.0
13.558000	29.8	Off	L1	20.2	20.2	50.0
26.390000	19.8	Off	L1	20.9	30.2	50.0

# EUT Information

Report NO : 730107  
 Test Mode : Mode 1  
 Test Voltage : 120Vac/60Hz  
 Phase : Neutral

ENV216 Auto Test FCC Power Bar - N

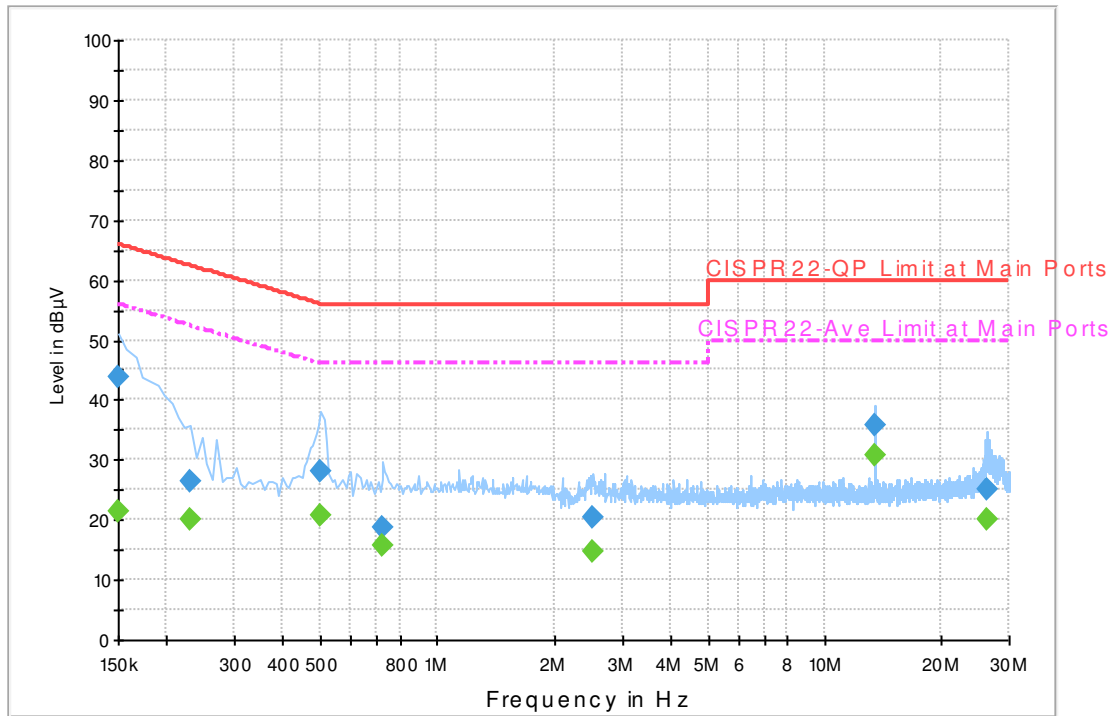

## Final Result 1

Frequency (MHz)	QuasiPeak (dBµV)	Filter	Line	Corr. (dB)	Margin (dB)	Limit (dBµV)
0.150000	43.9	Off	N	19.5	22.1	66.0
0.230000	26.3	Off	N	19.5	36.1	62.4
0.502000	27.9	Off	N	19.5	28.1	56.0
0.726000	18.8	Off	N	19.5	37.2	56.0
2.534000	20.4	Off	N	19.3	35.6	56.0
13.558000	35.7	Off	N	20.3	24.3	60.0
26.382000	25.0	Off	N	21.0	35.0	60.0

## Final Result 2

Frequency (MHz)	Average (dBµV)	Filter	Line	Corr. (dB)	Margin (dB)	Limit (dBµV)
0.150000	21.6	Off	N	19.5	34.4	56.0
0.230000	20.2	Off	N	19.5	32.2	52.4
0.502000	20.7	Off	N	19.5	25.3	46.0
0.726000	15.6	Off	N	19.5	30.4	46.0
2.534000	14.7	Off	N	19.3	31.3	46.0
13.558000	30.7	Off	N	20.3	19.3	50.0
26.382000	20.0	Off	N	21.0	30.0	50.0



## Appendix C. Radiated Spurious Emission

Test Engineer :	Tsung Lee, Stan Hsieh, and Kyle Chuang	Temperature :	24~25°C
		Relative Humidity :	45~50%

2.4GHz 2400~2483.5MHz

BLE (Band Edge @ 3m)

BLE	Note	Frequency	Level	Over	Limit	Read	Antenna	Cable	Preamp	Ant	Table	Peak	Pol.	
		( MHz )	( dBμV/m )	( dB )	Limit	Level	Factor	Loss	Factor	Pos	Pos	Avg.		
					Line	( dBμV )	( dB/m )	( dB )	( dB )	( cm )	( deg )	( P/A )	( H/V )	
BLE CH 00 2402MHz		2368.8	50.94	-23.06	74	51.58	27.19	5.39	33.22	100	177	P	H	
		2356.83	41.82	-12.18	54	42.58	27.14	5.33	33.23	100	177	A	H	
	*	2402	98.82	-	-	99.41	27.23	5.39	33.21	100	177	P	H	
	*	2402	98.23	-	-	98.82	27.23	5.39	33.21	100	177	A	H	
													H	
														H
			2333.52	51.3	-22.7	74	52.16	27.05	5.33	33.24	311	262	P	V
			2347.59	41.76	-12.24	54	42.56	27.1	5.33	33.23	311	262	A	V
	*		2402	97.43	-	-	98.02	27.23	5.39	33.21	311	262	P	V
	*		2402	96.84	-	-	97.43	27.23	5.39	33.21	311	262	A	V
														V
													V	
BLE CH 19 2440MHz		2330.86	50.77	-23.23	74	51.63	27.05	5.33	33.24	100	168	P	H	
		2389.1	41.75	-12.25	54	42.35	27.23	5.39	33.22	100	168	A	H	
	*	2440	97.15	-	-	97.55	27.37	5.42	33.19	100	168	P	H	
	*	2440	96.14	-	-	96.54	27.37	5.42	33.19	100	168	A	H	
			2488.8	51.02	-22.98	74	51.23	27.5	5.46	33.17	100	168	P	H
			2493.77	42.15	-11.85	54	42.35	27.5	5.46	33.16	100	168	A	H
			2358.44	50.85	-23.15	74	51.61	27.14	5.33	33.23	308	266	P	V
			2388.54	41.82	-12.18	54	42.42	27.23	5.39	33.22	308	266	A	V
	*		2440	95.96	-	-	96.36	27.37	5.42	33.19	308	266	P	V
	*		2440	95.37	-	-	95.77	27.37	5.42	33.19	308	266	A	V
			2489.01	51.37	-22.63	74	51.58	27.5	5.46	33.17	308	266	P	V
		2497.34	42.24	-11.76	54	42.44	27.5	5.46	33.16	308	266	A	V	



<b>BLE CH 39 2480MHz</b>	*	2480	95.83	-	-	96.1	27.46	5.44	33.17	114	167	P	H
	*	2480	95.32	-	-	95.59	27.46	5.44	33.17	114	167	A	H
		2483.56	60.61	-13.39	74	60.86	27.46	5.46	33.17	114	167	P	H
		2483.52	47.23	-6.77	54	47.48	27.46	5.46	33.17	114	167	A	H
													H
													H
	*	2480	93.97	-	-	94.24	27.46	5.44	33.17	342	267	P	V
	*	2480	93.34	-	-	93.61	27.46	5.44	33.17	342	267	A	V
		2483.64	59.21	-14.79	74	59.46	27.46	5.46	33.17	342	267	P	V
		2483.52	45.84	-8.16	54	46.09	27.46	5.46	33.17	342	267	A	V
													V
													V
<b>Remark</b>	1. No other spurious found. 2. All results are PASS against Peak and Average limit line.												



2.4GHz 2400~2483.5MHz

BLE (Harmonic @ 3m)

BLE	Note	Frequency ( MHz )	Level ( dBμV/m )	Over Limit ( dB )	Limit Line ( dBμV/m )	Read Level ( dBμV )	Antenna Factor ( dB/m )	Cable Loss ( dB )	Preamp Factor ( dB )	Ant Pos ( cm )	Table Pos ( deg )	Peak Avg. ( P/A )	Pol. ( H/V )	
BLE CH 00 2402MHz		4804	43.31	-30.69	74	62.64	31.42	7.58	58.33	100	0	P	H	
													H	
													H	
													H	
			4804	41.31	-32.69	74	60.64	31.42	7.58	58.33	100	0	P	V
														V
														V
BLE CH 19 2440MHz		4880	42.47	-31.53	74	61.45	31.56	7.7	58.24	100	0	P	H	
		7320	49.34	-24.66	74	62.73	36.22	9.49	59.1	100	0	P	H	
													H	
													H	
			4880	43.4	-30.6	74	62.38	31.56	7.7	58.24	100	0	P	V
			7320	53.68	-20.32	74	67.07	36.22	9.49	59.1	396	319	P	V
			7320	49.72	-4.28	54	63.11	36.22	9.49	59.1	396	319	A	V
BLE CH 39 2480MHz		4960	45.35	-28.65	74	63.83	31.73	7.93	58.14	100	0	P	H	
		7440	49.46	-24.54	74	62.53	36.49	9.61	59.17	100	0	P	H	
													H	
													H	
			4960	45.92	-28.08	74	64.4	31.73	7.93	58.14	100	0	P	V
			7440	53.01	-20.99	74	66.08	36.49	9.61	59.17	384	333	P	V
			7440	48.77	-5.23	54	61.84	36.49	9.61	59.17	384	333	A	V
Remark	1. No other spurious found.													
	2. All results are PASS against Peak and Average limit line.													



Emission below 1GHz

2.4GHz BLE (LF)

BLE	Note	Frequency	Level	Over	Limit	Read	Antenna	Cable	Preamp	Ant	Table	Peak	Pol.	
		( MHz )	( dBμV/m )	( dB )	( dBμV/m )	( dBμV )	( dB/m )	( dB )	( dB )	( cm )	( deg )	( P/A )	( H/V )	
2.4GHz BLE LF		116.67	30	-13.5	43.5	44.01	17.62	1.14	32.77			P	H	
		201.45	31.01	-12.49	43.5	46.23	16.05	1.48	32.75			P	H	
		240.6	37.92	-8.08	46	51.05	17.98	1.62	32.73	100	0	P	H	
		304.2	30.36	-15.64	46	41.35	19.84	1.88	32.71			P	H	
		346.9	28.15	-17.85	46	37.83	21.11	1.94	32.73			P	H	
		959.4	32.06	-13.94	46	30.42	30	3.29	31.65			P	H	
													H	
													H	
													H	
													H	
													H	
													H	
			30	26.22	-13.78	40	32.23	26.1	0.65	32.76			P	V
			40.8	26.49	-13.51	40	38.65	19.94	0.65	32.75			P	V
			165.81	30.5	-13	43.5	45.26	16.52	1.48	32.76	100	0	P	V
			431.6	24.15	-21.85	46	31.88	22.91	2.16	32.8			P	V
			799.8	30.13	-15.87	46	32.16	27.9	2.97	32.9			P	V
			958.7	32.02	-13.98	46	30.38	30	3.29	31.65			P	V
														V
														V
													V	
													V	
													V	
Remark	1. No other spurious found. 2. All results are PASS against limit line.													



**Note symbol**

*	<b>Fundamental Frequency</b> which can be ignored. However, the level of any unwanted emissions shall not exceed the level of the fundamental frequency.
!	Test result is <b>over limit</b> line.
P/A	<b>Peak</b> or <b>Average</b>
H/V	<b>Horizontal</b> or <b>Vertical</b>



A calculation example for radiated spurious emission is shown as below:

WIFI	Note	Frequency	Level	Over	Limit	Read	Antenna	Cable	Preamp	Ant	Table	Peak	Pol.
Ant.				Limit	Line	Level	Factor	Loss	Factor	Pos	Pos	Avg.	
1+2		( MHz )	( dBμV/m )	( dB )	( dBμV/m )	( dBμV )	( dB/m )	( dB )	( dB )	( cm )	( deg )	( P/A )	( H/V )
802.11b		2390	55.45	-18.55	74	54.51	32.22	4.58	35.86	103	308	P	H
CH 01													
2412MHz		2390	43.54	-10.46	54	42.6	32.22	4.58	35.86	103	308	A	H

- Level(dBμV/m) =  
Antenna Factor(dB/m) + Cable Loss(dB) + Read Level(dBμV) - Preamp Factor(dB)
- Over Limit(dB) = Level(dBμV/m) – Limit Line(dBμV/m)

**For Peak Limit @ 2390MHz:**

- Level(dBμV/m)  
= Antenna Factor(dB/m) + Cable Loss(dB) + Read Level(dBμV) - Preamp Factor(dB)  
= 32.22(dB/m) + 4.58(dB) + 54.51(dBμV) – 35.86 (dB)  
= 55.45 (dBμV/m)
- Over Limit(dB)  
= Level(dBμV/m) – Limit Line(dBμV/m)  
= 55.45(dBμV/m) – 74(dBμV/m)  
= -18.55(dB)

**For Average Limit @ 2390MHz:**

- Level(dBμV/m)  
= Antenna Factor(dB/m) + Cable Loss(dB) + Read Level(dBμV) - Preamp Factor(dB)  
= 32.22(dB/m) + 4.58(dB) + 42.6(dBμV) – 35.86 (dB)  
= 43.54 (dBμV/m)
- Over Limit(dB)  
= Level(dBμV/m) – Limit Line(dBμV/m)  
= 43.54(dBμV/m) – 54(dBμV/m)  
= -10.46(dB)

**Both peak and average measured complies with the limit line, so test result is “PASS”.**





## Appendix D. Radiated Spurious Emission Plots

<b>Test Engineer :</b>	Tsung Lee, Stan Hsieh, Kyle Chuang and Arthur Hsieh	<b>Temperature :</b>	24~25°C
		<b>Relative Humidity :</b>	45~50%

### Note symbol

-L	<b>Low channel location</b>
-R	<b>High channel location</b>



2.4GHz 2400~2483.5MHz

BLE (Band Edge @ 3m)

BLE	2.4GHz 2400~2483.5MHz Band Edge @ 3m	
ANT	BLE CH00 2402MHz	
1	Horizontal	Fundamental
Peak	<p>Site : 03CH10-HY Condition : PEAK_BE_74 3m HORN 91200-HF HORIZONTAL : RBW:1000.000KHz VBW:3000.000KHz SWT:Auto</p>	<p>Site : 03CH10-HY Condition : PEAK_74 3m HORN 91200-HF HORIZONTAL : RBW:1000.000KHz VBW:3000.000KHz SWT:Auto</p>
Avg.	<p>Site : 03CH10-HY Condition : AVG_BE_54 3m HORN 91200-HF HORIZONTAL : RBW:1000.000KHz VBW:3.000KHz SWT:Auto</p>	<p>Site : 03CH10-HY Condition : AVG_54 3m HORN 91200-HF HORIZONTAL : RBW:1000.000KHz VBW:3.000KHz SWT:Auto</p>



BLE	2.4GHz 2400~2483.5MHz Band Edge @ 3m	
ANT	BLE CH00 2402MHz	
1	Vertical	Fundamental
<b>Peak</b>	<p>Site : 03CH10-HY Condition : PEAK_BE_74 3m HORN 9120D-HF VERTICAL : RBW:1000.000KHz VBW:3000.000KHz SWT:Auto</p>	<p>Site : 03CH10-HY Condition : PEAK_74 3m HORN 9120D-HF VERTICAL : RBW:1000.000KHz VBW:3000.000KHz SWT:Auto</p>
<b>Avg</b>	<p>Site : 03CH10-HY Condition : AVG_BE_54 3m HORN 9120D-HF VERTICAL : RBW:1000.000KHz VBW:3.000KHz SWT:Auto</p>	<p>Site : 03CH10-HY Condition : AVG_54 3m HORN 9120D-HF VERTICAL : RBW:1000.000KHz VBW:3.000KHz SWT:Auto</p>

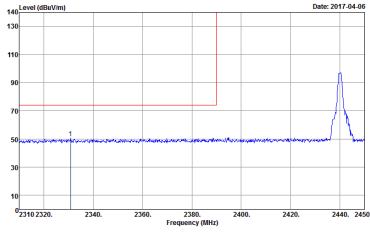
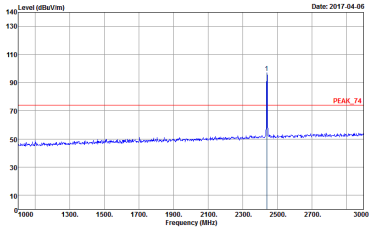
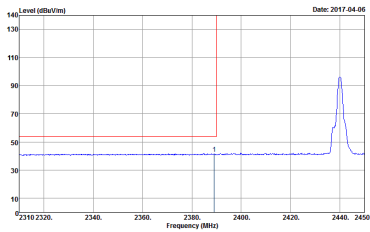
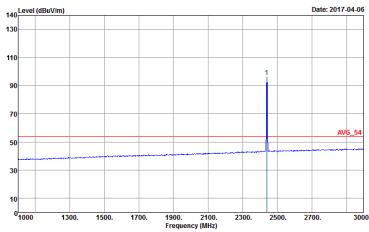

BLE	2.4GHz 2400~2483.5MHz Band Edge @ 3m	
ANT	BLE CH19 2440MHz - L	
1	Horizontal	Fundamental
Peak	 <p>Level (dBW/m) vs Frequency (MHz) plot for Horizontal orientation. The x-axis ranges from 2310 to 2450 MHz, and the y-axis ranges from 0 to 140 dBW/m. A significant peak is observed at approximately 2440 MHz, reaching a level of about 100 dBW/m. A red horizontal line is drawn at approximately 75 dBW/m. The plot is dated 2017-04-06.</p> <p>Site : 03CH10-HY Condition : PEAK_BE_74 3m HORN 91200-HF HORIZONTAL : RBW:1000.000KHz VBW:3000.000KHz SWT:Auto</p>	 <p>Level (dBW/m) vs Frequency (MHz) plot for Fundamental orientation. The x-axis ranges from 1800 to 3000 MHz, and the y-axis ranges from 0 to 140 dBW/m. A significant peak is observed at approximately 2440 MHz, reaching a level of about 100 dBW/m. A red horizontal line is drawn at approximately 75 dBW/m. The plot is dated 2017-04-06.</p> <p>Site : 03CH10-HY Condition : PEAK_74 3m HORN 91200-HF HORIZONTAL : RBW:1000.000KHz VBW:3000.000KHz SWT:Auto</p>
Avg.	 <p>Level (dBW/m) vs Frequency (MHz) plot for Horizontal orientation. The x-axis ranges from 2310 to 2450 MHz, and the y-axis ranges from 0 to 140 dBW/m. A peak is observed at approximately 2440 MHz, reaching a level of about 100 dBW/m. A red horizontal line is drawn at approximately 55 dBW/m. The plot is dated 2017-04-06.</p> <p>Site : 03CH10-HY Condition : AVG_BE_54 3m HORN 91200-HF HORIZONTAL : RBW:1000.000KHz VBW:3000.000KHz SWT:Auto</p>	 <p>Level (dBW/m) vs Frequency (MHz) plot for Fundamental orientation. The x-axis ranges from 1800 to 3000 MHz, and the y-axis ranges from 0 to 140 dBW/m. A peak is observed at approximately 2440 MHz, reaching a level of about 100 dBW/m. A red horizontal line is drawn at approximately 55 dBW/m. The plot is dated 2017-04-06.</p> <p>Site : 03CH10-HY Condition : AVG_54 3m HORN 91200-HF HORIZONTAL : RBW:1000.000KHz VBW:3000.000KHz SWT:Auto</p>



BLE	2.4GHz 2400~2483.5MHz Band Edge @ 3m	
ANT	BLE CH19 2440MHz - R	
1	Horizontal	Fundamental
<p><b>Peak</b></p>	<p>Site : 03CH10-HY Condition : PEAK_BE_74 3m HORN 91200-HF HORIZONTAL : RBW:1000.000kHz VBW:3000.000kHz SWT:Auto</p>	<p>Left blank</p>
<p><b>Avg.</b></p>	<p>Site : 03CH10-HY Condition : AVG_BE_54 3m HORN 91200-HF HORIZONTAL : RBW:1000.000kHz VBW:3.000kHz SWT:Auto</p>	<p>Left blank</p>

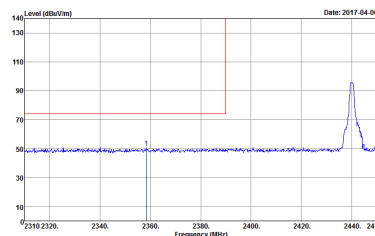
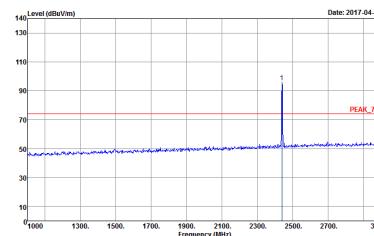
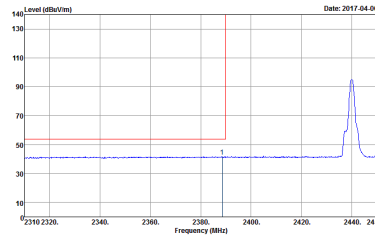
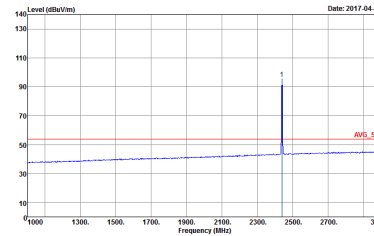

BLE	2.4GHz 2400~2483.5MHz Band Edge @ 3m	
ANT	BLE CH19 2440MHz - L	
1	Vertical	Fundamental
<p><b>Peak</b></p>	 <p>Site : 03CH10-HY Condition : PEAK_BE_74 3m HORN 9120D-HF VERTICAL : RBW:1000.000kHz VBW:3000.000kHz SWT:Auto</p>	 <p>Site : 03CH10-HY Condition : PEAK_74 3m HORN 9120D-HF VERTICAL : RBW:1000.000kHz VBW:3000.000kHz SWT:Auto</p>
<p><b>Avg.</b></p>	 <p>Site : 03CH10-HY Condition : AVG_BE_54 3m HORN 9120D-HF VERTICAL : RBW:1000.000kHz VBW:3.000kHz SWT:Auto</p>	 <p>Site : 03CH10-HY Condition : AVG_54 3m HORN 9120D-HF VERTICAL : RBW:1000.000kHz VBW:3.000kHz SWT:Auto</p>

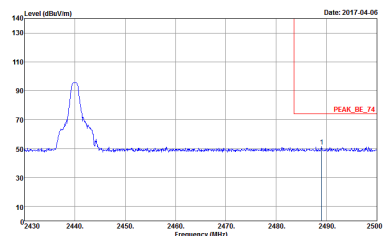
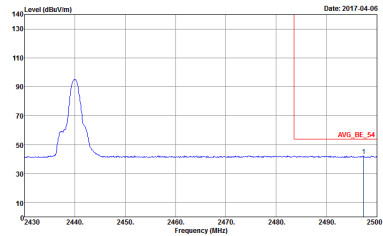

BLE	2.4GHz 2400~2483.5MHz Band Edge @ 3m	
ANT	BLE CH19 2440MHz - R	
1	Vertical	Fundamental
<p><b>Peak</b></p>	 <p>Site : 03CH10-HY Condition : PEAK_BE_74 3m HORN 91200-HF VERTICAL : RBW:1000.000KHz VBW:3000.000KHz SWT:Auto</p>	<p>Left blank</p>
<p><b>Avg.</b></p>	 <p>Site : 03CH10-HY Condition : AVG_BE_54 3m HORN 91200-HF VERTICAL : RBW:1000.000KHz VBW:3.000KHz SWT:Auto</p>	<p>Left blank</p>

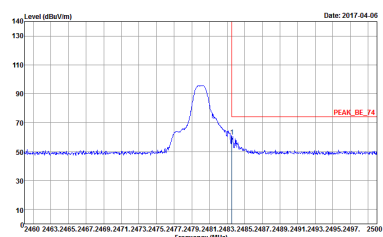
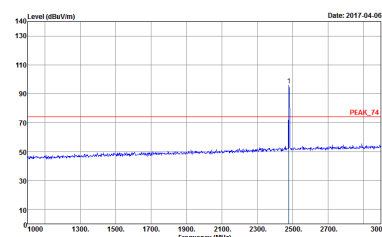
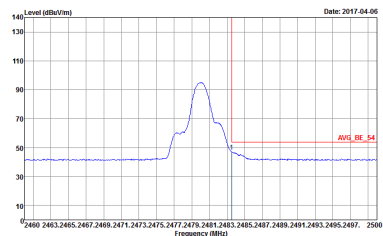
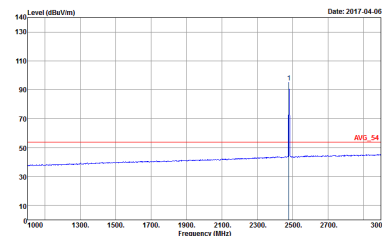

BLE	2.4GHz 2400~2483.5MHz Band Edge @ 3m	
ANT	BLE CH39 2480MHz	
1	Horizontal	Fundamental
Peak	 <p>Site : 03CH10-1HY Condition : PEAK_BE_74 3m HORN 91200-HF HORIZONTAL : RBW:1000.000KHz VBW:3000.000KHz SWT:Auto</p>	 <p>Site : 03CH10-1HY Condition : PEAK_74 3m HORN 91200-HF HORIZONTAL : RBW:1000.000KHz VBW:3000.000KHz SWT:Auto</p>
Avg.	 <p>Site : 03CH10-1HY Condition : AVG_BE_54 3m HORN 91200-HF HORIZONTAL : RBW:1000.000KHz VBW:3.000KHz SWT:Auto</p>	 <p>Site : 03CH10-1HY Condition : AVG_54 3m HORN 91200-HF HORIZONTAL : RBW:1000.000KHz VBW:3.000KHz SWT:Auto</p>



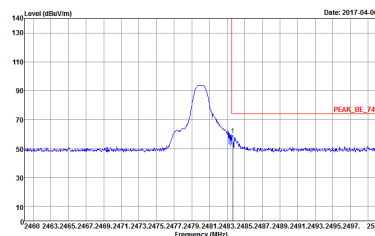
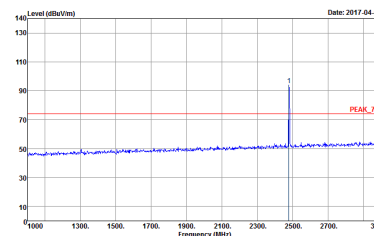
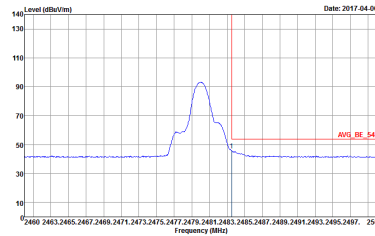
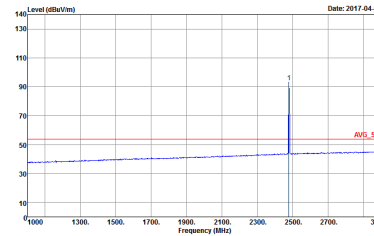

BLE	2.4GHz 2400~2483.5MHz Band Edge @ 3m	
ANT	BLE CH39 2480MHz	
1	Vertical	Fundamental
<p><b>Peak</b></p>	 <p>Site : 03CH10-HY Condition : PEAK_BE_74 3m HORN 9120D-HF VERTICAL : RBW:1000.000KHz VBW:3000.000KHz SWT:Auto</p>	 <p>Site : 03CH10-HY Condition : PEAK_74 3m HORN 9120D-HF VERTICAL : RBW:1000.000KHz VBW:3000.000KHz SWT:Auto</p>
<p><b>Avg.</b></p>	 <p>Site : 03CH10-HY Condition : AVG_BE_54 3m HORN 9120D-HF VERTICAL : RBW:1000.000KHz VBW:3.000KHz SWT:Auto</p>	 <p>Site : 03CH10-HY Condition : AVG_54 3m HORN 9120D-HF VERTICAL : RBW:1000.000KHz VBW:3.000KHz SWT:Auto</p>



2.4GHz 2400~2483.5MHz  
BLE (Harmonic @ 3m)

BLE	2.4GHz 2400~2483.5MHz Harmonic @ 3m	
ANT	BLE CH00 2402MHz	
1	Horizontal	Vertical
<p><b>Peak</b> <b>Avg.</b></p>	<p>Site : 03CH10-HY Condition : PEAK_74 3m HORN_9170_406_0584 HORIZONTAL Detector : Peak</p>	<p>Site : 03CH10-HY Condition : PEAK_74 3m HORN_9170_406_0584 VERTICAL Detector : Peak</p>



<b>BLE</b>	<b>2.4GHz 2400~2483.5MHz Harmonic @ 3m</b>	
<b>ANT</b>	<b>BLE CH19 2440MHz</b>	
<b>1</b>	<b>Horizontal</b>	<b>Vertical</b>
<b>Peak Avg.</b>	<p>Site : 03CH10-IY Condition : PEAK_74 3m HORN_9170_40G_0584 HORIZONTAL Detector : Peak</p>	<p>Site : 03CH10-IY Condition : PEAK_74 3m HORN_9170_40G_0584 VERTICAL Detector : Peak</p>



<b>BLE</b>	<b>2.4GHz 2400~2483.5MHz Harmonic @ 3m</b>	
<b>ANT</b>	<b>BLE CH39 2480MHz</b>	
<b>1</b>	<b>Horizontal</b>	<b>Vertical</b>
<b>Peak</b>	<p>Site : 03CH10-IY Condition : PEAK_74 3m HORN_9170_406_0584 HORIZONTAL Detector : Peak</p>	<p>Site : 03CH10-IY Condition : PEAK_74 3m HORN_9170_406_0584 VERTICAL Detector : Peak</p>



Emission below 1GHz  
2.4GHz BLE (LF)

BLE	2.4GHz 2400~2483.5MHz	
ANT	BLE LF	
1	Horizontal	Vertical
QP / Peak	<p>Site : 03CH10-HY Condition : QP 3m 8E-LOG 6111D-LF HORIZONTAL Detector : Peak</p>	<p>Site : 03CH10-HY Condition : QP 3m 8E-LOG 6111D-LF VERTICAL Detector : Peak</p>

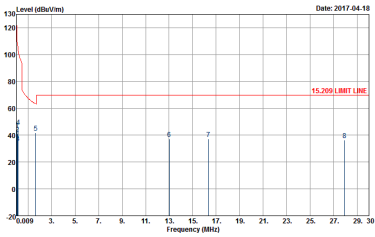
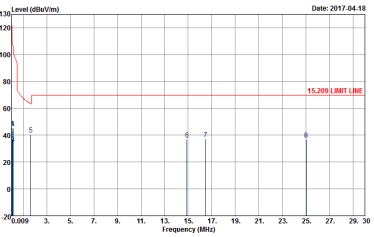

Emission below 30MHz  
9kHz~30MHz

ANT	9kHz~30MHz																																																																																																																																																																																					
1	Horizontal	Vertical																																																																																																																																																																																				
QP / Avg.	 <p>Site : 03CH10-HY Condition : 15.209 LIMIT LINE 3m LOOP_HFH2-ZZ_100315 HORIZONTAL Project : 730107 Mode : 14</p> <table border="1"> <thead> <tr> <th>Freq</th> <th>Level</th> <th>Over</th> <th>Limit</th> <th>ReadAntenna</th> <th>Cable</th> <th>A/Pos</th> <th>T/Pos</th> <th>Remark</th> </tr> <tr> <th>MHz</th> <th>dBuV/m</th> <th>dB</th> <th>dBuV/m</th> <th>dBuV</th> <th>dB/m</th> <th>cm</th> <th>deg</th> <th></th> </tr> </thead> <tbody> <tr><td>1</td><td>0.86</td><td>44.13</td><td>-67.83</td><td>111.96</td><td>24.86</td><td>20.86</td><td>0.01</td><td>--- Average</td></tr> <tr><td>2</td><td>0.10</td><td>40.96</td><td>-66.51</td><td>107.47</td><td>20.96</td><td>19.99</td><td>0.01</td><td>--- QP</td></tr> <tr><td>3</td><td>0.11</td><td>34.23</td><td>-72.29</td><td>106.52</td><td>14.24</td><td>19.98</td><td>0.01</td><td>--- Average</td></tr> <tr><td>4</td><td>0.14</td><td>46.24</td><td>-57.34</td><td>103.58</td><td>26.28</td><td>19.95</td><td>0.01</td><td>--- Average</td></tr> <tr><td>5</td><td>1.64</td><td>41.79</td><td>-21.61</td><td>63.31</td><td>21.69</td><td>19.93</td><td>0.08</td><td>0 QP</td></tr> <tr><td>6</td><td>13.02</td><td>37.15</td><td>-32.85</td><td>70.00</td><td>16.70</td><td>20.85</td><td>0.34</td><td>--- QP</td></tr> <tr><td>7</td><td>16.35</td><td>37.22</td><td>-32.78</td><td>70.00</td><td>16.74</td><td>20.89</td><td>0.39</td><td>--- QP</td></tr> <tr><td>8</td><td>27.92</td><td>36.50</td><td>-33.50</td><td>70.00</td><td>15.50</td><td>20.61</td><td>0.33</td><td>--- QP</td></tr> </tbody> </table>	Freq	Level	Over	Limit	ReadAntenna	Cable	A/Pos	T/Pos	Remark	MHz	dBuV/m	dB	dBuV/m	dBuV	dB/m	cm	deg		1	0.86	44.13	-67.83	111.96	24.86	20.86	0.01	--- Average	2	0.10	40.96	-66.51	107.47	20.96	19.99	0.01	--- QP	3	0.11	34.23	-72.29	106.52	14.24	19.98	0.01	--- Average	4	0.14	46.24	-57.34	103.58	26.28	19.95	0.01	--- Average	5	1.64	41.79	-21.61	63.31	21.69	19.93	0.08	0 QP	6	13.02	37.15	-32.85	70.00	16.70	20.85	0.34	--- QP	7	16.35	37.22	-32.78	70.00	16.74	20.89	0.39	--- QP	8	27.92	36.50	-33.50	70.00	15.50	20.61	0.33	--- QP	 <p>Site : 03CH10-HY Condition : 15.209 LIMIT LINE 3m LOOP_HFH2-ZZ_100315 VERTICAL Project : 730107 Mode : 14</p> <table border="1"> <thead> <tr> <th>Freq</th> <th>Level</th> <th>Over</th> <th>Limit</th> <th>ReadAntenna</th> <th>Cable</th> <th>A/Pos</th> <th>T/Pos</th> <th>Remark</th> </tr> <tr> <th>MHz</th> <th>dBuV/m</th> <th>dB</th> <th>dBuV/m</th> <th>dBuV</th> <th>dB/m</th> <th>cm</th> <th>deg</th> <th></th> </tr> </thead> <tbody> <tr><td>1</td><td>0.06</td><td>45.39</td><td>-66.58</td><td>111.97</td><td>25.32</td><td>20.86</td><td>0.01</td><td>--- Average</td></tr> <tr><td>2</td><td>0.10</td><td>37.25</td><td>-70.55</td><td>107.80</td><td>17.25</td><td>19.99</td><td>0.01</td><td>--- QP</td></tr> <tr><td>3</td><td>0.11</td><td>33.34</td><td>-73.13</td><td>106.47</td><td>13.35</td><td>19.98</td><td>0.01</td><td>--- Average</td></tr> <tr><td>4</td><td>0.15</td><td>45.11</td><td>-58.93</td><td>104.04</td><td>25.15</td><td>19.95</td><td>0.01</td><td>--- Average</td></tr> <tr><td>5</td><td>1.65</td><td>40.55</td><td>-22.72</td><td>63.27</td><td>20.54</td><td>19.93</td><td>0.08</td><td>0 QP</td></tr> <tr><td>6</td><td>14.89</td><td>36.90</td><td>-33.10</td><td>70.00</td><td>16.47</td><td>20.85</td><td>0.38</td><td>--- QP</td></tr> <tr><td>7</td><td>16.46</td><td>37.19</td><td>-32.81</td><td>70.00</td><td>16.71</td><td>20.89</td><td>0.39</td><td>--- QP</td></tr> <tr><td>8</td><td>25.02</td><td>36.77</td><td>-33.23</td><td>70.00</td><td>15.85</td><td>20.58</td><td>0.34</td><td>--- QP</td></tr> </tbody> </table>	Freq	Level	Over	Limit	ReadAntenna	Cable	A/Pos	T/Pos	Remark	MHz	dBuV/m	dB	dBuV/m	dBuV	dB/m	cm	deg		1	0.06	45.39	-66.58	111.97	25.32	20.86	0.01	--- Average	2	0.10	37.25	-70.55	107.80	17.25	19.99	0.01	--- QP	3	0.11	33.34	-73.13	106.47	13.35	19.98	0.01	--- Average	4	0.15	45.11	-58.93	104.04	25.15	19.95	0.01	--- Average	5	1.65	40.55	-22.72	63.27	20.54	19.93	0.08	0 QP	6	14.89	36.90	-33.10	70.00	16.47	20.85	0.38	--- QP	7	16.46	37.19	-32.81	70.00	16.71	20.89	0.39	--- QP	8	25.02	36.77	-33.23	70.00	15.85	20.58	0.34	--- QP
	Freq	Level	Over	Limit	ReadAntenna	Cable	A/Pos	T/Pos	Remark																																																																																																																																																																													
MHz	dBuV/m	dB	dBuV/m	dBuV	dB/m	cm	deg																																																																																																																																																																															
1	0.86	44.13	-67.83	111.96	24.86	20.86	0.01	--- Average																																																																																																																																																																														
2	0.10	40.96	-66.51	107.47	20.96	19.99	0.01	--- QP																																																																																																																																																																														
3	0.11	34.23	-72.29	106.52	14.24	19.98	0.01	--- Average																																																																																																																																																																														
4	0.14	46.24	-57.34	103.58	26.28	19.95	0.01	--- Average																																																																																																																																																																														
5	1.64	41.79	-21.61	63.31	21.69	19.93	0.08	0 QP																																																																																																																																																																														
6	13.02	37.15	-32.85	70.00	16.70	20.85	0.34	--- QP																																																																																																																																																																														
7	16.35	37.22	-32.78	70.00	16.74	20.89	0.39	--- QP																																																																																																																																																																														
8	27.92	36.50	-33.50	70.00	15.50	20.61	0.33	--- QP																																																																																																																																																																														
Freq	Level	Over	Limit	ReadAntenna	Cable	A/Pos	T/Pos	Remark																																																																																																																																																																														
MHz	dBuV/m	dB	dBuV/m	dBuV	dB/m	cm	deg																																																																																																																																																																															
1	0.06	45.39	-66.58	111.97	25.32	20.86	0.01	--- Average																																																																																																																																																																														
2	0.10	37.25	-70.55	107.80	17.25	19.99	0.01	--- QP																																																																																																																																																																														
3	0.11	33.34	-73.13	106.47	13.35	19.98	0.01	--- Average																																																																																																																																																																														
4	0.15	45.11	-58.93	104.04	25.15	19.95	0.01	--- Average																																																																																																																																																																														
5	1.65	40.55	-22.72	63.27	20.54	19.93	0.08	0 QP																																																																																																																																																																														
6	14.89	36.90	-33.10	70.00	16.47	20.85	0.38	--- QP																																																																																																																																																																														
7	16.46	37.19	-32.81	70.00	16.71	20.89	0.39	--- QP																																																																																																																																																																														
8	25.02	36.77	-33.23	70.00	15.85	20.58	0.34	--- QP																																																																																																																																																																														



Verification of Radiated Spurious Emissions  
below 30MHz at open-area test site  
9kHz~30MHz

ANT	9kHz~30MHz																																																																																																																																																																																																							
1	Horizontal	Vertical																																																																																																																																																																																																						
QP / Avg.	<p>Site : OS03-LK Condition : 15.000 LIMITED LINE Sm LOOP_HFHU_ZZ_100315 HORIZONTAL Project : 730107 Mode : 730107 Date: 2017-04-18</p> <table border="1"> <thead> <tr> <th>Line</th> <th>Freq</th> <th>Level</th> <th>Limit</th> <th>Line</th> <th>Level</th> <th>Factor</th> <th>Loss</th> <th>ca</th> <th>req</th> <th>Remark</th> </tr> </thead> <tbody> <tr><td>1</td><td>0.06</td><td>41.27</td><td>-70.41</td><td>111.88</td><td>21.20</td><td>20.06</td><td>0.01</td><td>...</td><td>...</td><td>Average</td></tr> <tr><td>2</td><td>0.10</td><td>39.83</td><td>-67.41</td><td>107.44</td><td>19.83</td><td>19.99</td><td>0.01</td><td>...</td><td>...</td><td>QP</td></tr> <tr><td>3</td><td>0.11</td><td>35.47</td><td>-72.97</td><td>106.44</td><td>15.48</td><td>19.96</td><td>0.01</td><td>...</td><td>...</td><td>Average</td></tr> <tr><td>4</td><td>0.19</td><td>45.15</td><td>-57.86</td><td>103.15</td><td>19.45</td><td>19.84</td><td>0.01</td><td>...</td><td>...</td><td>Average</td></tr> <tr><td>5</td><td>0.38</td><td>38.84</td><td>-65.49</td><td>85.25</td><td>19.45</td><td>19.92</td><td>0.98</td><td>100</td><td>...</td><td>QP</td></tr> <tr><td>6</td><td>13.98</td><td>34.84</td><td>-66.16</td><td>70.00</td><td>19.45</td><td>20.05</td><td>0.36</td><td>...</td><td>...</td><td>QP</td></tr> <tr><td>7</td><td>16.98</td><td>37.16</td><td>-59.84</td><td>70.00</td><td>16.45</td><td>20.11</td><td>0.48</td><td>...</td><td>...</td><td>QP</td></tr> <tr><td>8</td><td>27.34</td><td>36.46</td><td>-55.54</td><td>70.00</td><td>15.51</td><td>20.62</td><td>0.33</td><td>...</td><td>...</td><td>QP</td></tr> </tbody> </table>	Line	Freq	Level	Limit	Line	Level	Factor	Loss	ca	req	Remark	1	0.06	41.27	-70.41	111.88	21.20	20.06	0.01	...	...	Average	2	0.10	39.83	-67.41	107.44	19.83	19.99	0.01	...	...	QP	3	0.11	35.47	-72.97	106.44	15.48	19.96	0.01	...	...	Average	4	0.19	45.15	-57.86	103.15	19.45	19.84	0.01	...	...	Average	5	0.38	38.84	-65.49	85.25	19.45	19.92	0.98	100	...	QP	6	13.98	34.84	-66.16	70.00	19.45	20.05	0.36	...	...	QP	7	16.98	37.16	-59.84	70.00	16.45	20.11	0.48	...	...	QP	8	27.34	36.46	-55.54	70.00	15.51	20.62	0.33	...	...	QP	<p>Site : OS03-LK Condition : 15.000 LIMITED LINE Sm LOOP_HFHU_ZZ_100315 VERTICAL Project : 730107 Mode : 730107 Date: 2017-04-18</p> <table border="1"> <thead> <tr> <th>Line</th> <th>Freq</th> <th>Level</th> <th>Limit</th> <th>Line</th> <th>Level</th> <th>Factor</th> <th>Loss</th> <th>ca</th> <th>req</th> <th>Remark</th> </tr> </thead> <tbody> <tr><td>1</td><td>0.06</td><td>43.12</td><td>-68.66</td><td>111.78</td><td>23.05</td><td>20.06</td><td>0.01</td><td>...</td><td>...</td><td>Average</td></tr> <tr><td>2</td><td>0.10</td><td>36.96</td><td>-70.78</td><td>107.74</td><td>16.96</td><td>19.99</td><td>0.01</td><td>...</td><td>...</td><td>QP</td></tr> <tr><td>3</td><td>0.11</td><td>32.36</td><td>-73.86</td><td>106.32</td><td>13.37</td><td>19.98</td><td>0.01</td><td>...</td><td>...</td><td>Average</td></tr> <tr><td>4</td><td>0.19</td><td>45.02</td><td>-57.86</td><td>102.56</td><td>19.01</td><td>19.84</td><td>0.01</td><td>...</td><td>...</td><td>Average</td></tr> <tr><td>5</td><td>0.38</td><td>35.92</td><td>-64.60</td><td>84.00</td><td>19.25</td><td>19.92</td><td>0.58</td><td>100</td><td>...</td><td>QP</td></tr> <tr><td>6</td><td>13.98</td><td>35.41</td><td>-64.08</td><td>70.00</td><td>19.25</td><td>20.05</td><td>0.36</td><td>...</td><td>...</td><td>QP</td></tr> <tr><td>7</td><td>16.98</td><td>35.49</td><td>-54.51</td><td>70.00</td><td>14.97</td><td>20.12</td><td>0.40</td><td>...</td><td>...</td><td>QP</td></tr> <tr><td>8</td><td>27.49</td><td>34.18</td><td>-55.52</td><td>70.00</td><td>13.24</td><td>20.60</td><td>0.34</td><td>...</td><td>...</td><td>QP</td></tr> </tbody> </table>	Line	Freq	Level	Limit	Line	Level	Factor	Loss	ca	req	Remark	1	0.06	43.12	-68.66	111.78	23.05	20.06	0.01	...	...	Average	2	0.10	36.96	-70.78	107.74	16.96	19.99	0.01	...	...	QP	3	0.11	32.36	-73.86	106.32	13.37	19.98	0.01	...	...	Average	4	0.19	45.02	-57.86	102.56	19.01	19.84	0.01	...	...	Average	5	0.38	35.92	-64.60	84.00	19.25	19.92	0.58	100	...	QP	6	13.98	35.41	-64.08	70.00	19.25	20.05	0.36	...	...	QP	7	16.98	35.49	-54.51	70.00	14.97	20.12	0.40	...	...	QP	8	27.49	34.18	-55.52	70.00	13.24	20.60	0.34	...	...	QP
	Line	Freq	Level	Limit	Line	Level	Factor	Loss	ca	req	Remark																																																																																																																																																																																													
1	0.06	41.27	-70.41	111.88	21.20	20.06	0.01	...	...	Average																																																																																																																																																																																														
2	0.10	39.83	-67.41	107.44	19.83	19.99	0.01	...	...	QP																																																																																																																																																																																														
3	0.11	35.47	-72.97	106.44	15.48	19.96	0.01	...	...	Average																																																																																																																																																																																														
4	0.19	45.15	-57.86	103.15	19.45	19.84	0.01	...	...	Average																																																																																																																																																																																														
5	0.38	38.84	-65.49	85.25	19.45	19.92	0.98	100	...	QP																																																																																																																																																																																														
6	13.98	34.84	-66.16	70.00	19.45	20.05	0.36	...	...	QP																																																																																																																																																																																														
7	16.98	37.16	-59.84	70.00	16.45	20.11	0.48	...	...	QP																																																																																																																																																																																														
8	27.34	36.46	-55.54	70.00	15.51	20.62	0.33	...	...	QP																																																																																																																																																																																														
Line	Freq	Level	Limit	Line	Level	Factor	Loss	ca	req	Remark																																																																																																																																																																																														
1	0.06	43.12	-68.66	111.78	23.05	20.06	0.01	...	...	Average																																																																																																																																																																																														
2	0.10	36.96	-70.78	107.74	16.96	19.99	0.01	...	...	QP																																																																																																																																																																																														
3	0.11	32.36	-73.86	106.32	13.37	19.98	0.01	...	...	Average																																																																																																																																																																																														
4	0.19	45.02	-57.86	102.56	19.01	19.84	0.01	...	...	Average																																																																																																																																																																																														
5	0.38	35.92	-64.60	84.00	19.25	19.92	0.58	100	...	QP																																																																																																																																																																																														
6	13.98	35.41	-64.08	70.00	19.25	20.05	0.36	...	...	QP																																																																																																																																																																																														
7	16.98	35.49	-54.51	70.00	14.97	20.12	0.40	...	...	QP																																																																																																																																																																																														
8	27.49	34.18	-55.52	70.00	13.24	20.60	0.34	...	...	QP																																																																																																																																																																																														

## Appendix E. Duty Cycle Plots

Band	Duty Cycle(%)	T(us)	1/T(kHz)	VBW Setting
Bluetooth -LE	63.46	396	2.525252525	3kHz

### Bluetooth - LE

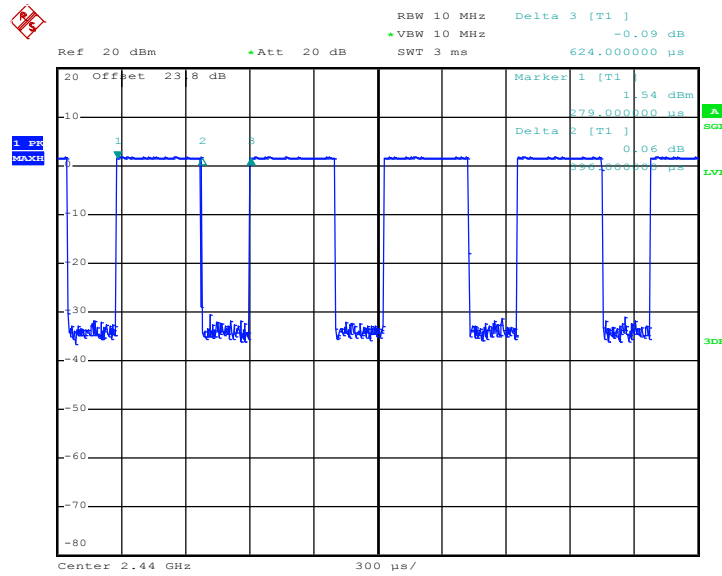

Date: 5.APR.2017 10:53:40