



FCC RADIO TEST REPORT

FCC ID : PY7-87261H
Equipment : GSM/WCDMA/LTE Phone with BT, DTS/UNII
a/b/g/n/ac/ax, GPS, WPC and NFC
Brand Name : Sony
Applicant : Sony Mobile Communications Inc.
4-12-3 Higashi-Shinagawa, Shinagawa-ku,
Tokyo, 140-0002, Japan
Manufacturer : Sony Mobile Communications Inc.
4-12-3 Higashi-Shinagawa, Shinagawa-ku,
Tokyo, 140-0002, Japan
Standard : FCC Part 15 Subpart C §15.247

The product was received on Dec. 04, 2019 and testing was started from Dec. 19, 2019 and completed on Feb. 20, 2020. We, SPORTON INTERNATIONAL INC. EMC & Wireless Communications Laboratory, would like to declare that the tested sample has been evaluated in accordance with the test procedures and has been in compliance with the applicable technical standards.

The report must not be used by the client to claim product certification, approval, or endorsement by TAF or any agency of government.

The test results in this report apply exclusively to the tested model / sample. Without written approval of SPORTON INTERNATIONAL INC. EMC & Wireless Communications Laboratory, the test report shall not be reproduced except in full.

Louis Wu

Approved by: Louis Wu

SPORTON INTERNATIONAL INC. EMC & Wireless Communications Laboratory
No. 52, Huaya 1st Rd., Guishan Dist., Taoyuan City, Taiwan (R.O.C.)



Table of Contents

History of this test report..... 3

Summary of Test Result..... 4

1 General Description 5

 1.1 Product Feature of Equipment Under Test..... 5

 1.2 Modification of EUT 5

 1.3 Testing Location 6

 1.4 Applicable Standards..... 6

2 Test Configuration of Equipment Under Test 7

 2.1 Carrier Frequency and Channel 7

 2.2 Test Mode..... 7

 2.3 Connection Diagram of Test System..... 8

 2.4 Support Unit used in test configuration and system 10

 2.5 EUT Operation Test Setup 10

 2.6 Measurement Results Explanation Example..... 10

3 Test Result 11

 3.1 6dB and 99% Bandwidth Measurement 11

 3.2 Output Power Measurement..... 13

 3.3 Power Spectral Density Measurement 14

 3.4 Conducted Band Edges and Spurious Emission Measurement 16

 3.5 Radiated Band Edges and Spurious Emission Measurement 53

 3.6 AC Conducted Emission Measurement..... 58

 3.7 Antenna Requirements..... 60

4 List of Measuring Equipment..... 61

5 Uncertainty of Evaluation..... 63

Appendix A. Conducted Test Results

Appendix B. AC Conducted Emission Test Result

Appendix C. Radiated Spurious Emission

Appendix D. Radiated Spurious Emission Plots

Appendix E. Duty Cycle Plots



History of this test report

Report No.	Version	Description	Issued Date
FR901542-02C	01	Initial issue of report	Feb. 06, 2020
FR901542-02C	02	Add simultaneous power.	Feb. 21, 2020



Summary of Test Result

Report Clause	Ref Std. Clause	Test Items	Result (PASS/FAIL)	Remark
3.1	15.247(a)(2)	6dB Bandwidth	Pass	-
3.1	2.1049	99% Occupied Bandwidth	Reporting only	-
3.2	15.247(b)	Power Output Measurement	Pass	-
3.3	15.247(e)	Power Spectral Density	Pass	-
3.4	15.247(d)	Conducted Band Edges	Pass	-
		Conducted Spurious Emission	Pass	-
3.5	15.247(d)	Radiated Band Edges and Radiated Spurious Emission	Pass	Under limit 7.32 dB at 43.580 MHz
3.6	15.207	AC Conducted Emission	Pass	Under limit 11.23 dB at 1.585 MHz
3.7	15.203 & 15.247(b)	Antenna Requirement	Pass	-

Declaration of Conformity:

The test results with all measurement uncertainty excluded are presented in accordance with the regulation limits or requirements declared by manufacturers.

Comments and Explanations:

The declared of product specification for EUT presented in the report are provided by the manufacturer, and the manufacturer takes all the responsibilities for the accuracy of product specification.

Reviewed by: Wii Chang**Report Producer: Yvonne Cheng**



1 General Description

1.1 Product Feature of Equipment Under Test

GSM/WCDMA/LTE, Bluetooth, DTS/UNII a/b/g/n/ac/ax, NFC, GNSS and WPC.

Standards-related Product Specification	
Antenna Type / Gain	<Ant. 1>: Loop Antenna with gain -2.40 dBi <Ant. 2>: Monopole Antenna with gain -11.40 dBi

EUT Information List			
HW Version	SW Version	S/N	Performed Test Item
A	0.261	BH950071J7 BH95006JJ7	RF conducted measurement
	2.98	QV7100AP2A	Radiated Spurious Emission
	2.94	QV7100FD2A	
	2.38	QV7100Q62A	AC Conducted Emission

Accessory List	
AC Adapter	Model Name : UCH32
	S/N: 6218W30200178 (for Radiated Spurious Emission) 6218W30200005 (for Conducted Emission)
Earphone	Model Name : STH40D
	S/N : S458096
Bluetooth Earphone	Model Name : SBH82D
	S/N : N/A
USB Cable	Model Name : UCB24
	S/N : N/A
Audio Cable	Model Name : EC234
	S/N : N/A

Note:

1. Above EUT list used are electrically identical per declared by manufacturer.
2. Above the accessories list are used to exercise the EUT during test, and the serial number of each type of accessories is listed in each section of this report. .
3. For other wireless features of this EUT, test report will be issued separately.

1.2 Modification of EUT

No modifications are made to the EUT during all test items.



1.3 Testing Location

Test Site	SPORTON INTERNATIONAL INC. EMC & Wireless Communications Laboratory	
Test Site Location	No.52, Huaya 1st Rd., Guishan Dist., Taoyuan City, Taiwan (R.O.C.) TEL: +886-3-327-3456 FAX: +886-3-328-4978	
Test Site No.	Sporton Site No.	
	TH05-HY	CO05-HY

Note: The test site complies with ANSI C63.4 2014 requirement.

Test Site	SPORTON INTERNATIONAL INC. EMC & Wireless Communications Laboratory	
Test Site Location	No.58, Aly. 75, Ln. 564, Wenhua 3rd, Rd., Guishan Dist., Taoyuan City, Taiwan (R.O.C.) TEL: +886-3-327-0868 FAX: +886-3-327-0855	
Test Site No.	Sporton Site No.	
	03CH16-HY	

Note: The test site complies with ANSI C63.4 2014 requirement.

FCC Designation No.: TW1190 and TW0007

1.4 Applicable Standards

According to the specifications of the manufacturer, the EUT must comply with the requirements of the following standards:

- ♦ FCC Part 15 Subpart C §15.247
- ♦ FCC KDB Publication No. 558074 D01 DTS Meas. Guidance v05r02
- ♦ FCC KDB 414788 D01 Radiated Test Site v01r01.
- ♦ FCC KDB 662911 D01 Multiple Transmitter Output v02r01.
- ♦ ANSI C63.10-2013

Remark:

1. All test items were verified and recorded according to the standards and without any deviation during the test.
2. This EUT has also been tested and complied with the requirements of FCC Part 15, Subpart B, recorded in a separate test report.

2 Test Configuration of Equipment Under Test

- a. The EUT has been associated with peripherals and configuration operated in a manner tended to maximize its emission characteristics in a typical application. Frequency range investigated: conduction emission (150 kHz to 30 MHz), radiation emission (9 kHz to the 10th harmonic of the highest fundamental frequency or to 40 GHz, whichever is lower). For radiated measurement, pre-scanned in three orthogonal panels, X, Y, Z and Accessory. The worst cases (X plane) were recorded in this report.

- b. AC power line Conducted Emission was tested under maximum output power.

2.1 Carrier Frequency and Channel

Frequency Band	Channel	Freq. (MHz)	Channel	Freq. (MHz)
2400-2483.5 MHz	1	2412	8	2447
	2	2417	9	2452
	3	2422	10	2457
	4	2427	11	2462
	5	2432	-	-
	6	2437	-	-
	7	2442	-	-

2.2 Test Mode

Final test modes are considering the modulation and worse data rates as below table.

Modulation	Data Rate
802.11b	1 Mbps
802.11g	6 Mbps
802.11n HT20	MCS0
802.11ax HE20	MCS0

Test Cases	
AC Conducted Emission	Mode 1 :GSM850 Idle + Bluetooth Link + WLAN (2.4GHz) Link + MPEG4 + USB Cable (Charging from Adapter) + Earphone + Battery Mode 2 :GSM850 Idle + Bluetooth Link + WLAN (2.4GHz) Link + MPEG4 + Earphone + Battery + WPC Charging pad (Charging from Adapter)

2.3 Connection Diagram of Test System

<AC Conducted Emission>

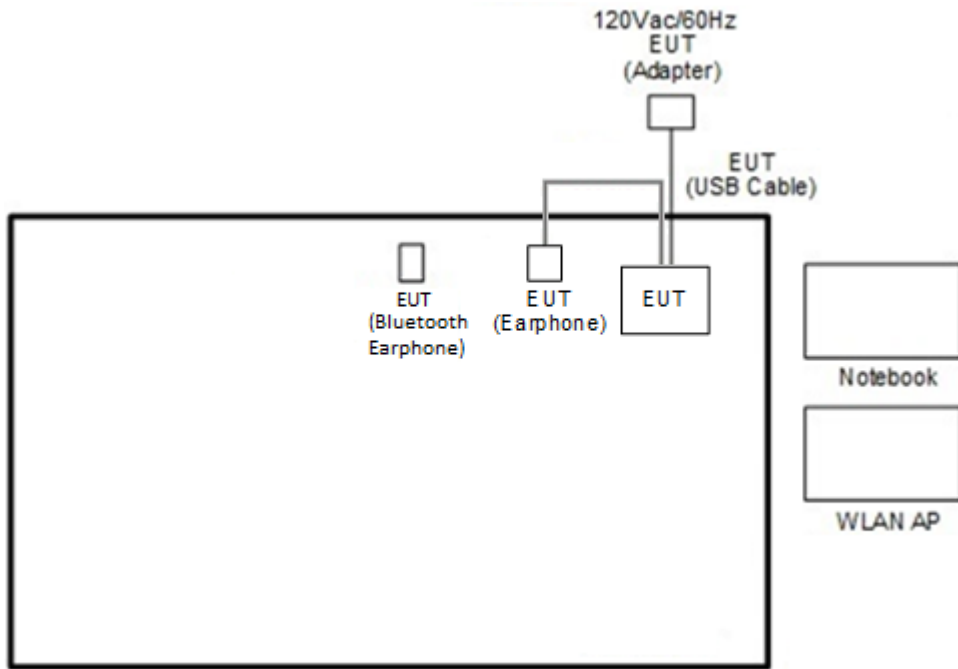

<AC Conducted Emission with WPC Charger>

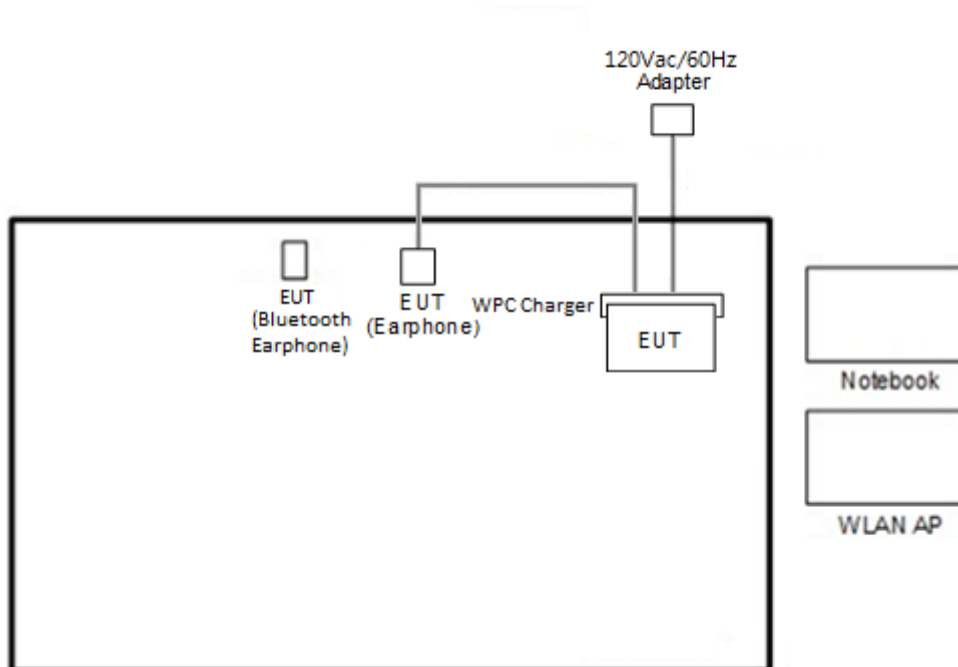

< For Radiated Emissions Measurement >

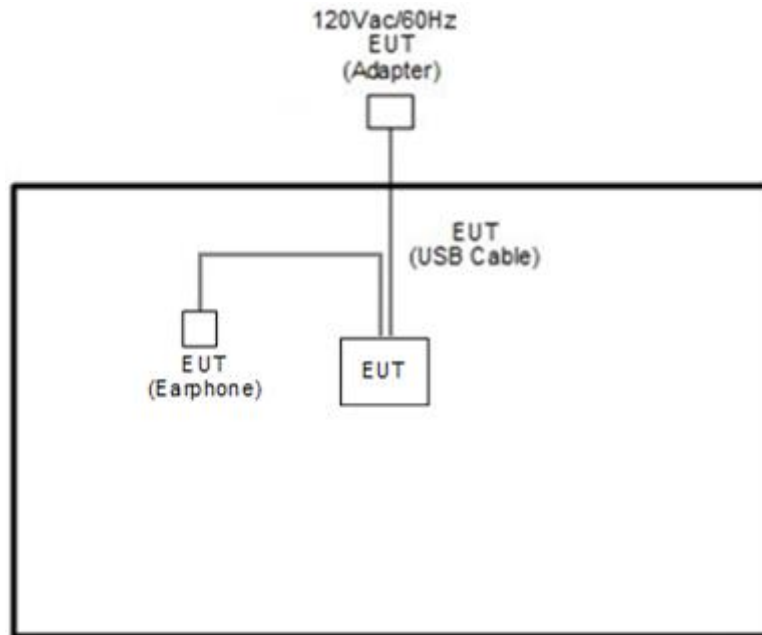

<For Radiated Emissions Measurement with WPC Charger>

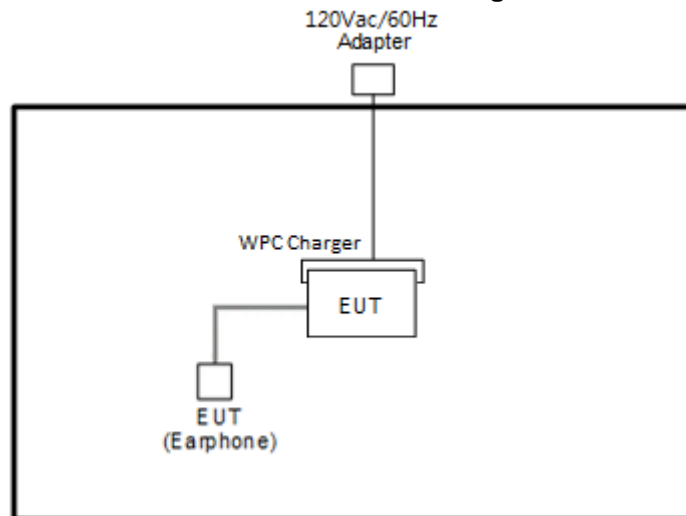



2.4 Support Unit used in test configuration and system

Item	Equipment	Trade Name	Model Name	FCC ID	Data Cable	Power Cord
1.	System Simulator	R&S	CMU 200	N/A	N/A	Unshielded, 1.8 m
2.	WLAN AP	ASUS	RT-AC66U	MSQ-RTAC66U	N/A	Unshielded, 1.8 m
3.	Notebook	DELL	Latitude E3400	FCC DoC	N/A	AC I/P: Unshielded, 1.2 m DC O/P: Shielded, 1.8 m
4.	SD Card	SanDisk	MicroSD HC	FCC DoC	N/A	N/A
5.	Wireless charging pad	belkin	F7U050	N/A	N/A	N/A

2.5 EUT Operation Test Setup

The RF test items, utility “FTMC_bridge_forURC_v0.39” was installed in Notebook which was programmed in order to make the EUT get into the engineering modes to provide channel selection, power level, data rate and the application type and for continuous transmitting signals.

2.6 Measurement Results Explanation Example

For all conducted test items:

The offset level is set in the spectrum analyzer to compensate the RF cable loss and attenuator factor between EUT conducted output port and spectrum analyzer. With the offset compensation, the spectrum analyzer reading level is exactly the EUT RF output level.

Example:

The spectrum analyzer offset is derived from RF cable loss and attenuator factor.

Offset = RF cable loss + attenuator factor.

Following shows an offset computation example with cable loss 4.2 dB and 10dB attenuator.

$$\begin{aligned} \text{Offset(dB)} &= \text{RF cable loss(dB)} + \text{attenuator factor(dB)}. \\ &= 4.2 + 10 = 14.2 \text{ (dB)} \end{aligned}$$

3 Test Result

3.1 6dB and 99% Bandwidth Measurement

3.1.1 Limit of 6dB and 99% Bandwidth

The minimum 6 dB bandwidth shall be at least 500 kHz.

3.1.2 Measuring Instruments

See list of measuring equipment of this test report.

3.1.3 Test Procedures

1. The testing follows the ANSI C63.10 Section 6.9.3 (OBW) and 11.8.1 (6dB BW).
2. The RF output of EUT was connected to the spectrum analyzer by RF cable and attenuator. The path loss was compensated to the results for each measurement.
3. Set to the maximum power setting and enable the EUT transmit continuously.
4. Make the measurement with the spectrum analyzer's resolution bandwidth (RBW) = 100 kHz. Set the Video bandwidth (VBW) = 300 kHz. In order to make an accurate measurement. The 6 dB bandwidth must be greater than 500 kHz.
5. For 99% Bandwidth Measurement, the spectrum analyzer's resolution bandwidth (RBW) is set 1-5% of the emission bandwidth and set the Video bandwidth (VBW) $\geq 3 * RBW$.
6. Measure and record the results in the test report.

3.1.4 Test Setup

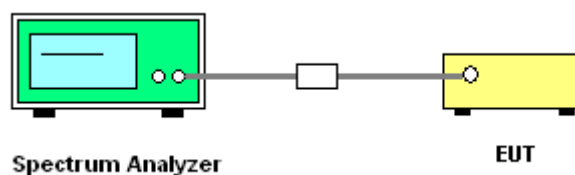



3.1.5 Test Result of 6dB and 99% Occupied Bandwidth

Please refer to Appendix A.

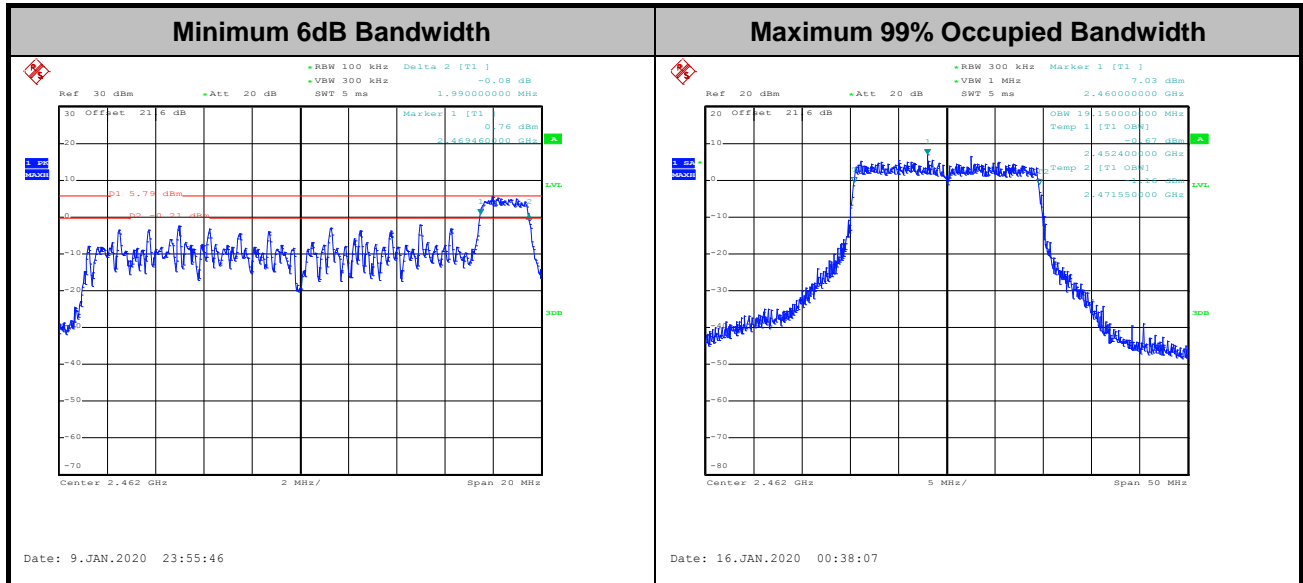

Note: The occupied channel bandwidth is maintained within the band of operation for all of the modulations.

3.2 Output Power Measurement

3.2.1 Limit of Output Power

For systems using digital modulation in the 2400-2483.5MHz, the limit for peak output power is 30dBm. If transmitting antenna with directional gain greater than 6dBi is used, the peak output power from the intentional radiator shall be reduced below the above stated value by the amount in dB that the directional gain of the antenna exceeds 6 dBi. In case of point-to-point operation, the limit has to be reduced by 1dB for every 3dB that the directional gain of the antenna exceeds 6dBi.

3.2.2 Measuring Instruments

See list of measuring equipment of this test report.

3.2.3 Test Procedures

1. For Peak Power, the testing follows ANSI C63.10 Section 11.9.1.3 PKPM1
2. For Average Power, the testing follows ANSI C63.10 Section 11.9.2.3.2 Method AVGPM-G
3. The RF output of EUT was connected to the power meter by RF cable and attenuator. The path loss was compensated to the results for each measurement.
4. Set to the maximum power setting and enable the EUT transmit continuously.
5. Measure the conducted output power and record the results in the test report.
6. For MIMO mode, calculation method follows FCC KDB 662911 D01 Multiple Transmitter Output v02r01.

3.2.4 Test Setup

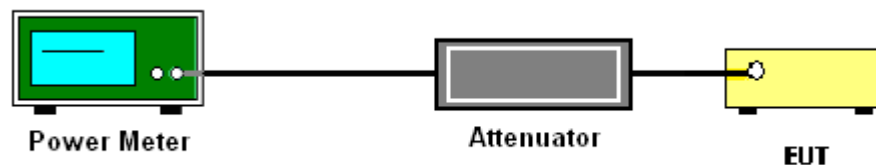

3.2.5 Test Result of Peak output Power

Please refer to Appendix A.

3.2.6 Test Result of Average Output Power (Reporting Only)

Please refer to Appendix A.



3.3 Power Spectral Density Measurement

3.3.1 Limit of Power Spectral Density

The peak power spectral density shall not be greater than 8dBm in any 3kHz band at any time interval of continuous transmission.

3.3.2 Measuring Instruments

See list of measuring equipment of this test report.

3.3.3 Test Procedures

1. The testing follows the ANSI C63.10 Section 11.10.2 Method PKPSD.
2. The RF output of EUT was connected to the spectrum analyzer by RF cable and attenuator. The path loss was compensated to the results for each measurement.
3. Set to the maximum power setting and enable the EUT transmit continuously.
4. Make the measurement with the spectrum analyzer's resolution bandwidth (RBW) = 3 kHz. Video bandwidth VBW = 10 kHz In order to make an accurate measurement, set the span to 1.5 times DTS Channel Bandwidth. (6dB BW)
5. Detector = peak, Sweep time = auto couple, Trace mode = max hold, Allow trace to fully stabilize. Use the peak marker function to determine the maximum power level.
6. Measure and record the results in the test report.
7. For MIMO mode, calculation method follows FCC KDB 662911 D01 Multiple Transmitter Output v02r01.

If measurements performed using method (2) plus $10 \log(N)$ exceeds the emission limit, the test should choose method (1) before declaring that the device fails the emission limit.

Method (1): Measure and sum the spectra across the outputs.

The total final Power Spectral Density is from a device with 2 transmitter outputs. The spectrum measurements of the individual outputs are all performed with the same span and number of points, the spectrum value in the first spectral bin of output 1 is summed with that in the first spectral bin of output 2 to obtain the value for the first frequency bin of the summed spectrum.

Method (2): Measure and add $10 \log(N)$ dB, where N is the number of outputs. (N=2)

3.3.4 Test Setup



3.3.5 Test Result of Power Spectral Density

Please refer to Appendix A.

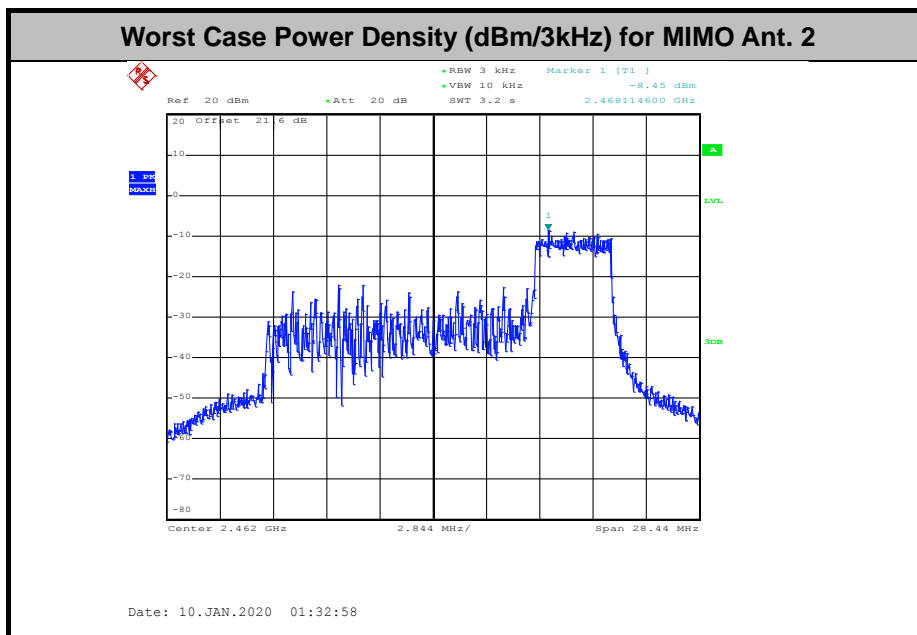
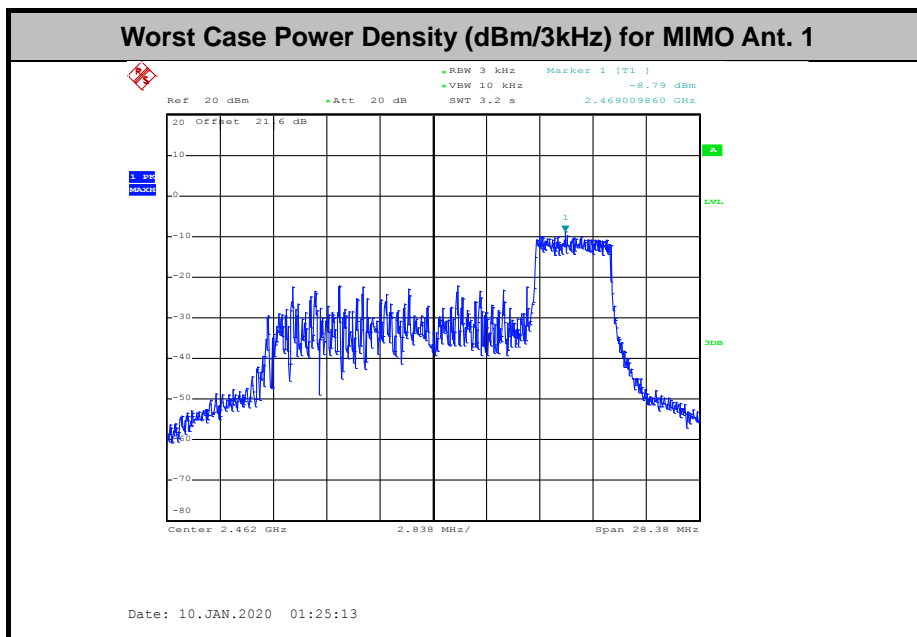

3.4 Conducted Band Edges and Spurious Emission Measurement

3.4.1 Limit of Conducted Band Edges and Spurious Emission Measurement

In any 100 kHz bandwidth outside of the authorized frequency band, the emissions which fall in the non-restricted bands shall be attenuated at least 20 dB / 30dB relative to the maximum PSD level in 100 kHz by RF conducted measurement.

3.4.2 Measuring Instruments

See list of measuring equipment of this test report.

3.4.3 Test Procedures

1. The testing follows the ANSI C63.10 Section 11.11.3 Emission level measurement.
2. The RF output of EUT was connected to the spectrum analyzer by RF cable and attenuator. The path loss was compensated to the results for each measurement.
3. Set to the maximum power setting and enable the EUT transmit continuously.
4. Set RBW = 100 kHz, VBW=300 kHz, Peak Detector. Unwanted Emissions measured in any 100 kHz bandwidth outside of the authorized frequency band shall be attenuated by at least 20 dB relative to the maximum in-band peak PSD level in 100 kHz when maximum peak conducted output power procedure is used. If the transmitter complies with the conducted power limits based on the use of RMS averaging over a time interval, the attenuation required under this paragraph shall be 30 dB instead of 20 dB per 15.247(d).
5. Measure and record the results in the test report.
6. The RF fundamental frequency should be excluded against the limit line in the operating frequency band.

3.4.4 Test Setup

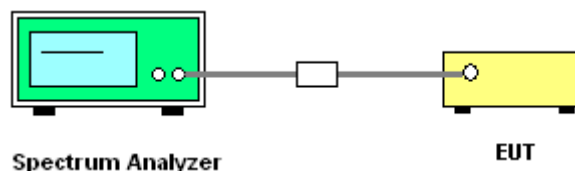



3.4.5 Test Result of Conducted Band Edges and Spurious Emission

Test Engineer :	Derek Hsu and Shiming Liu	Temperature :	21~25°C
		Relative Humidity :	51~54%

Number of TX = 2, Ant. 1 (Measured)

Test Mode :	802.11b	Test Channel :	01
-------------	---------	----------------	----

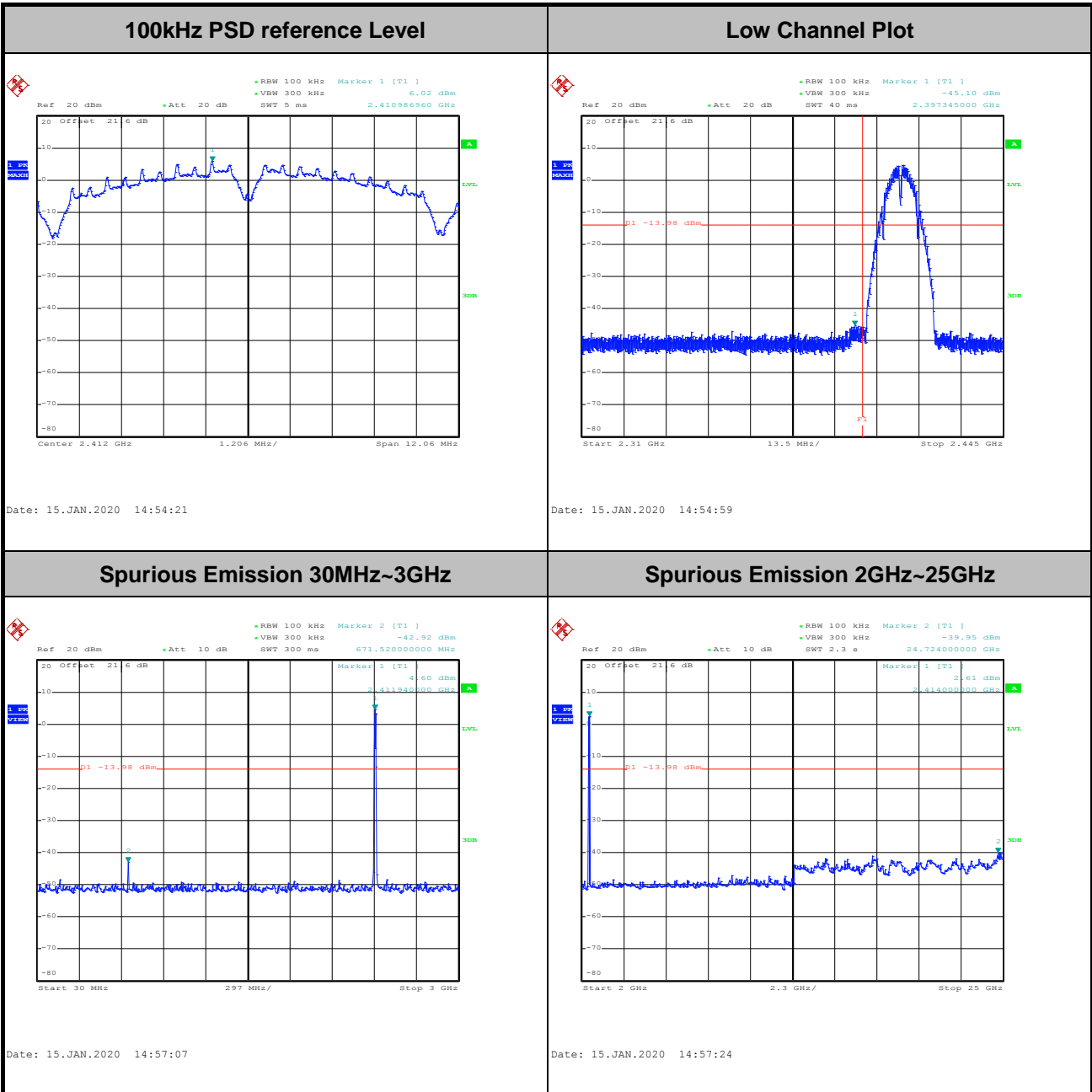



Test Mode :	802.11b	Test Channel :	06
-------------	---------	----------------	----

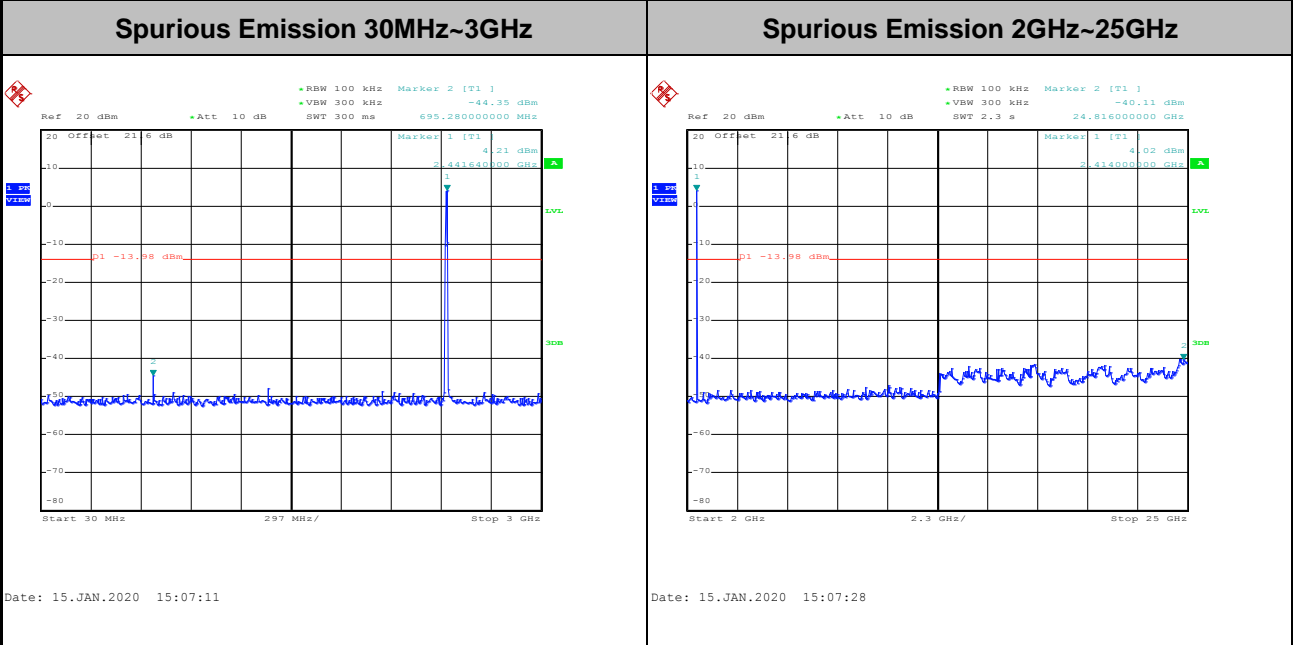
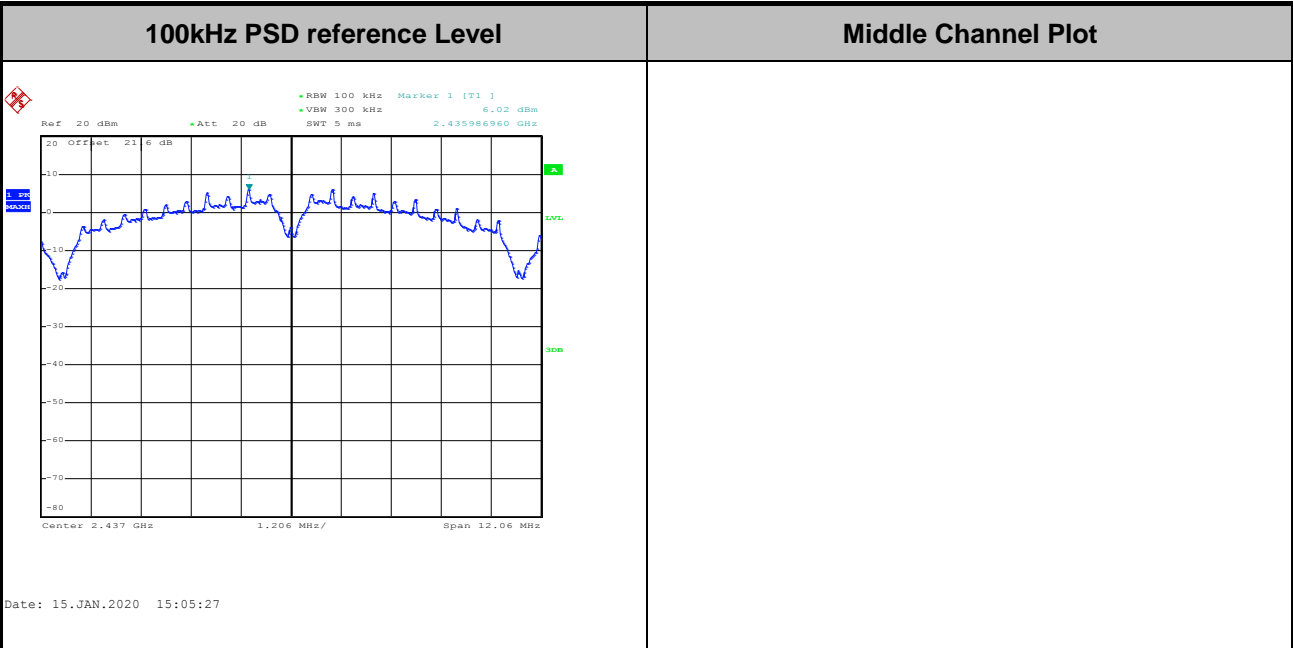



Test Mode :	802.11b	Test Channel :	11
-------------	---------	----------------	----

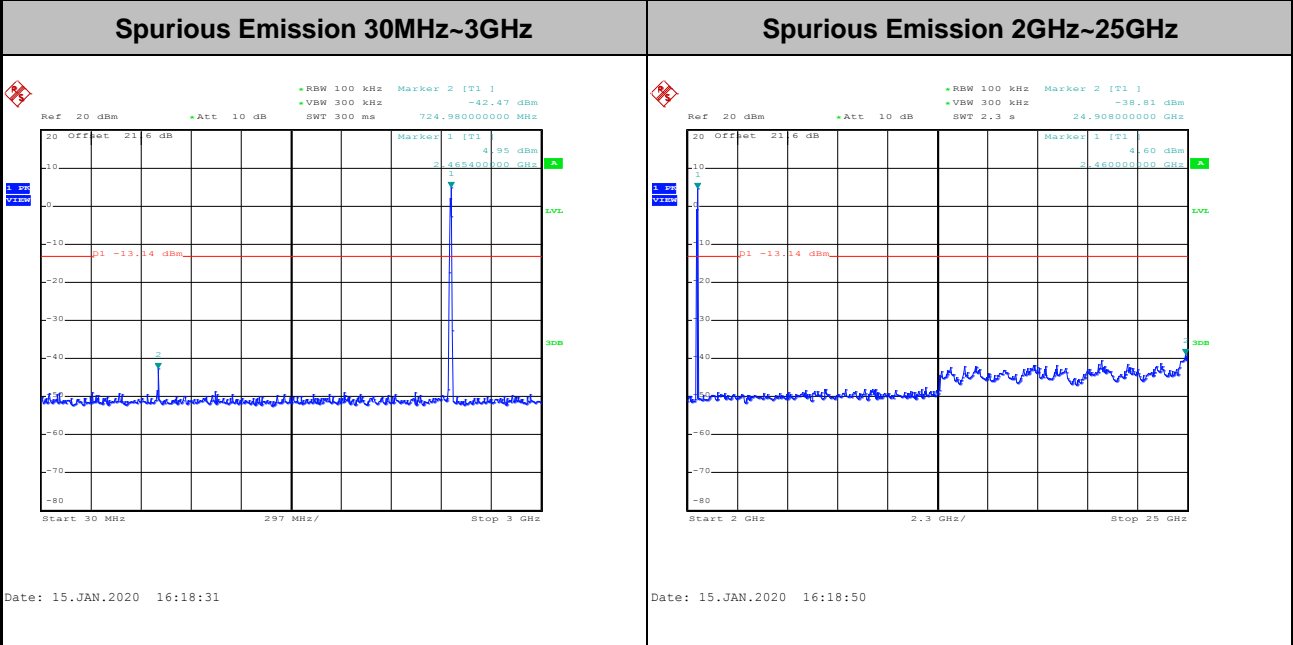
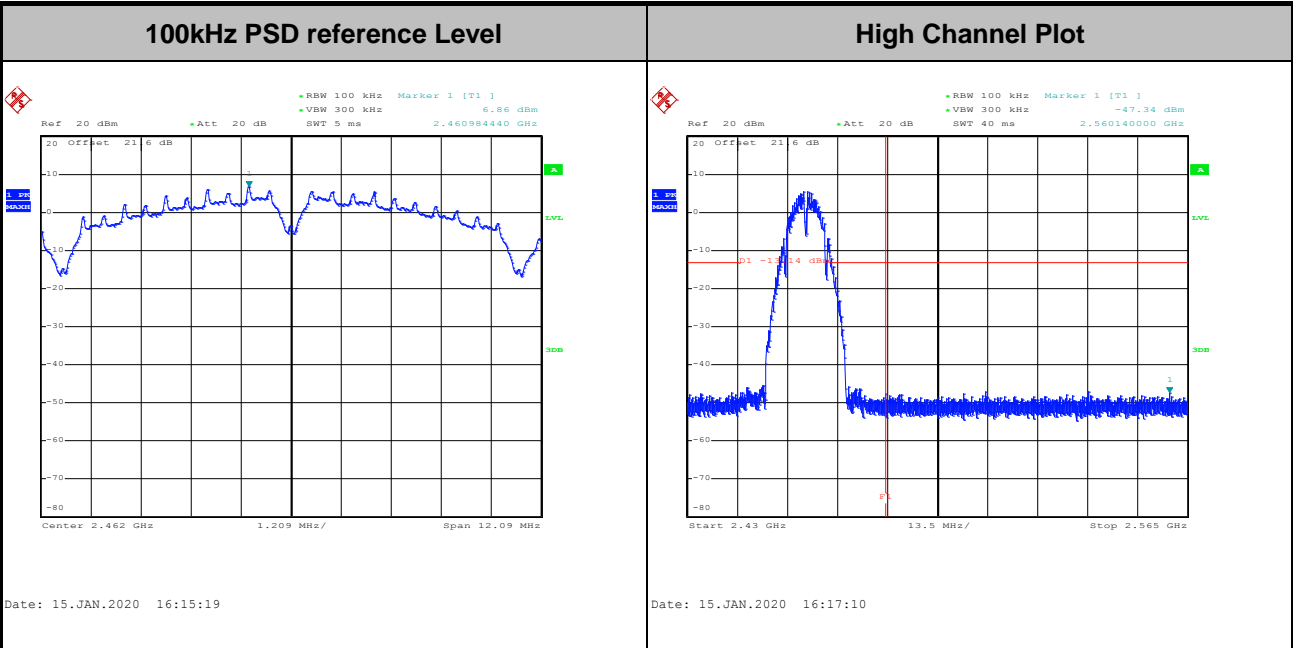



Test Mode :	802.11g	Test Channel :	01
-------------	---------	----------------	----

100kHz PSD reference Level	Low Channel Plot
-----------------------------------	-------------------------

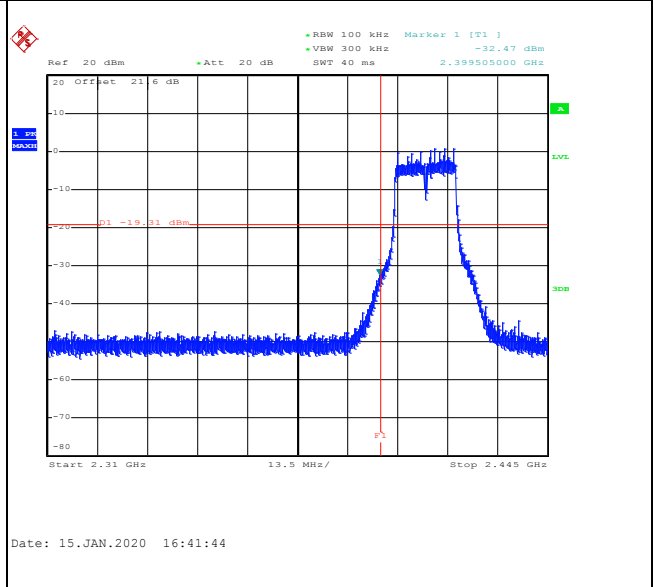
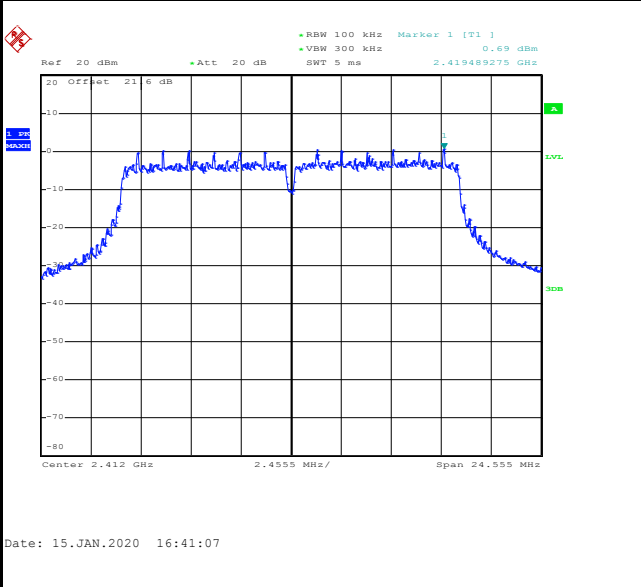

Spurious Emission 30MHz~3GHz	Spurious Emission 2GHz~25GHz
-------------------------------------	-------------------------------------

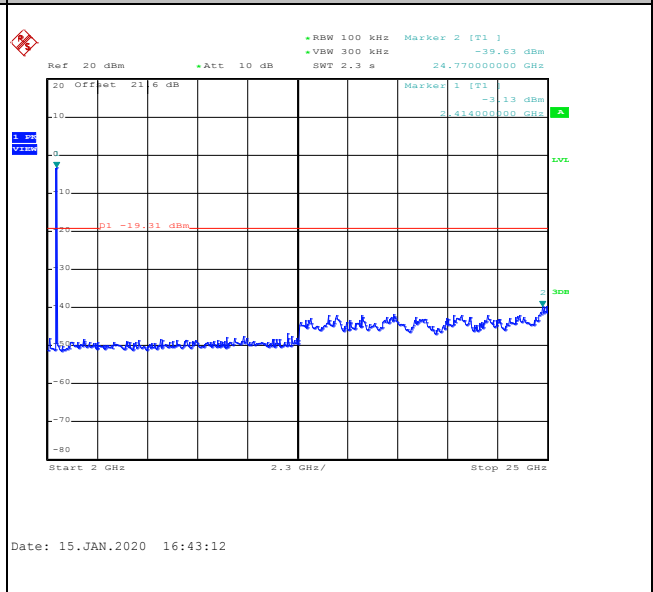
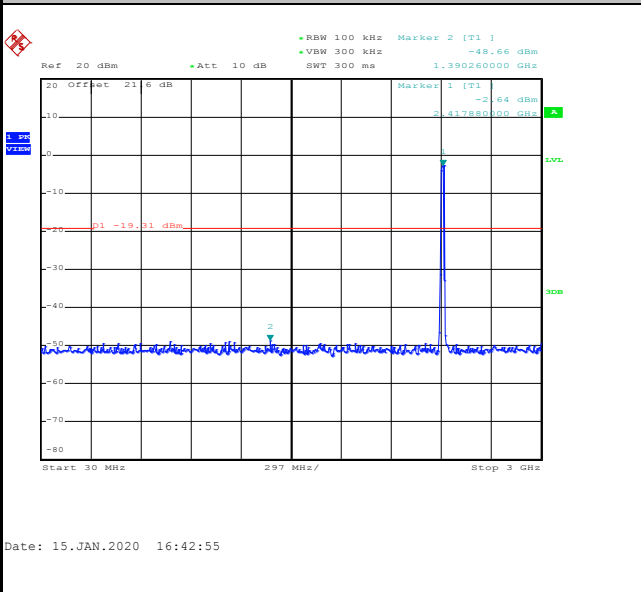



Test Mode :	802.11g	Test Channel :	06
-------------	---------	----------------	----

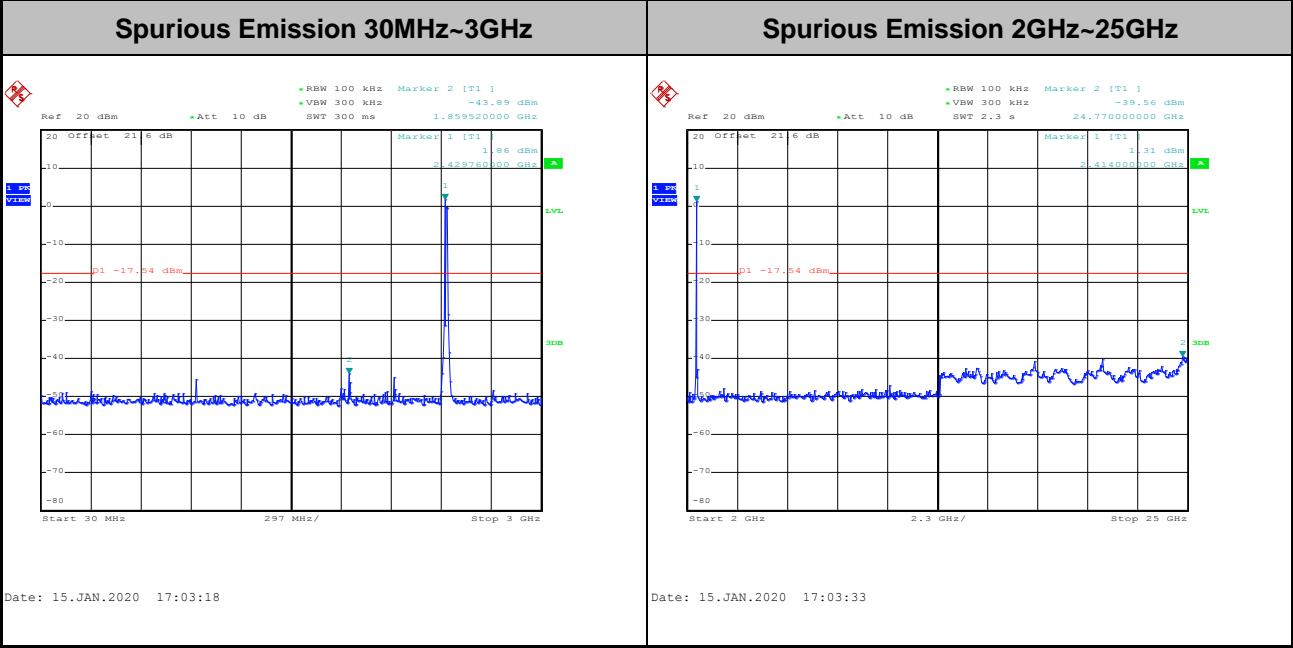
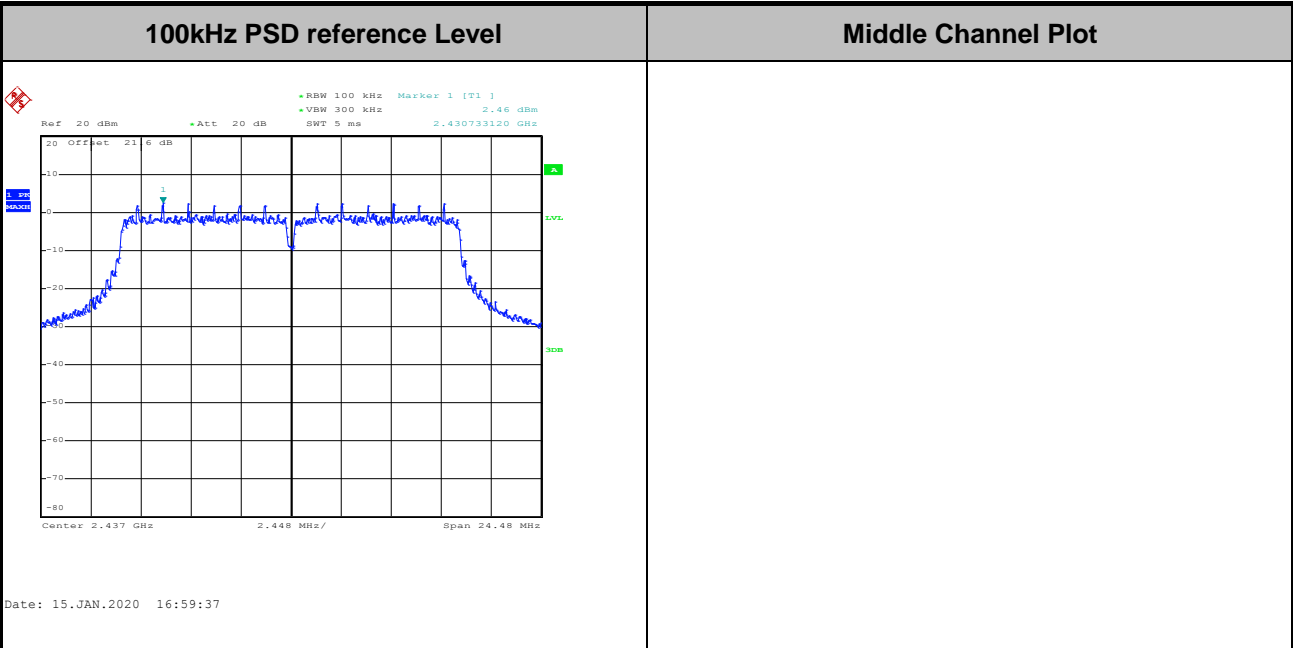



Test Mode :	802.11g	Test Channel :	11
-------------	---------	----------------	----

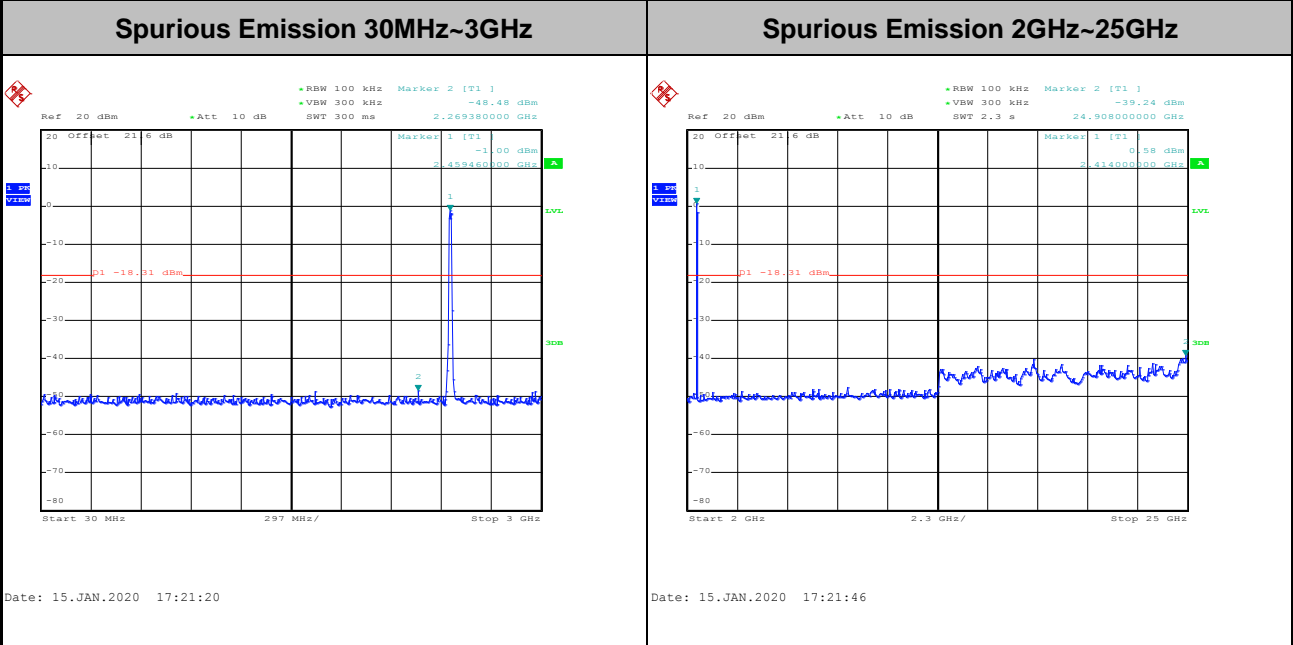
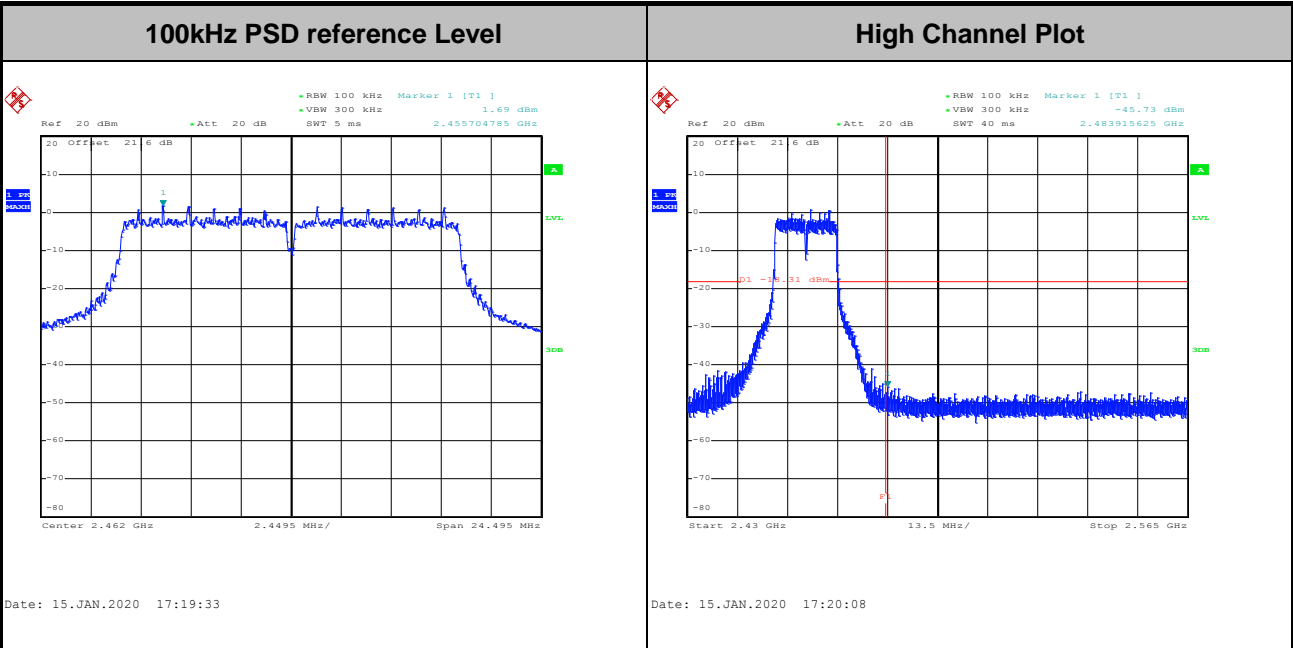



Test Mode :	802.11n HT20	Test Channel :	01
-------------	--------------	----------------	----

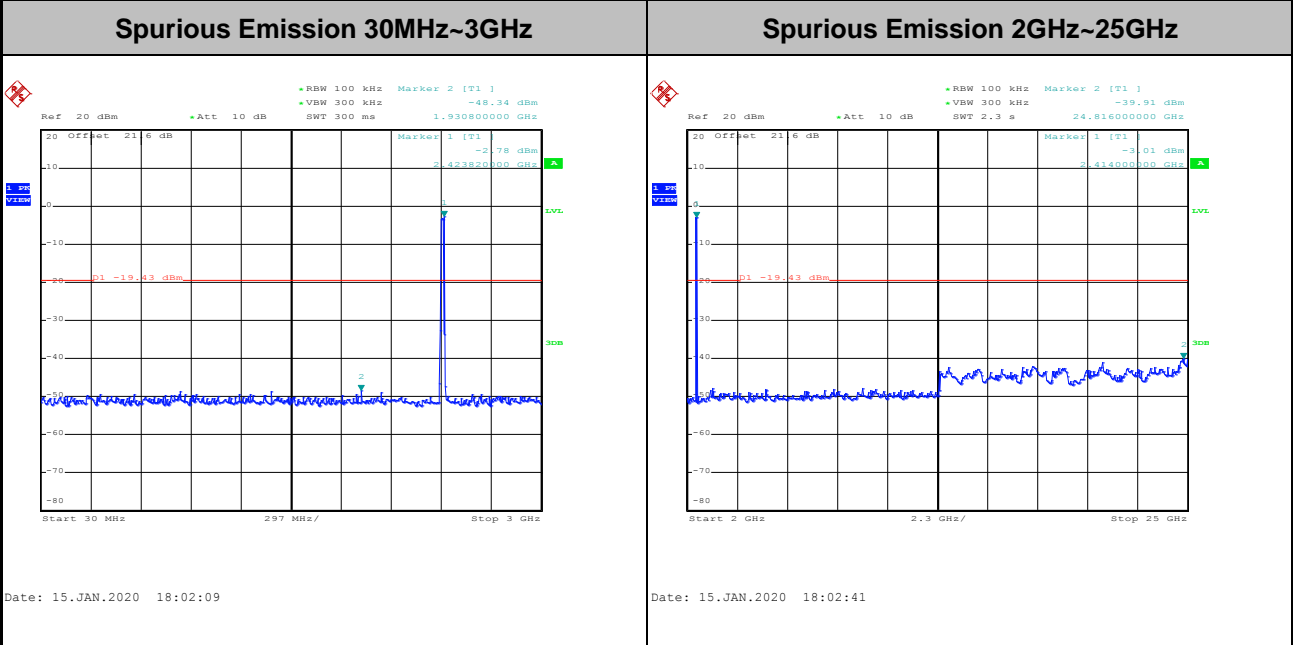
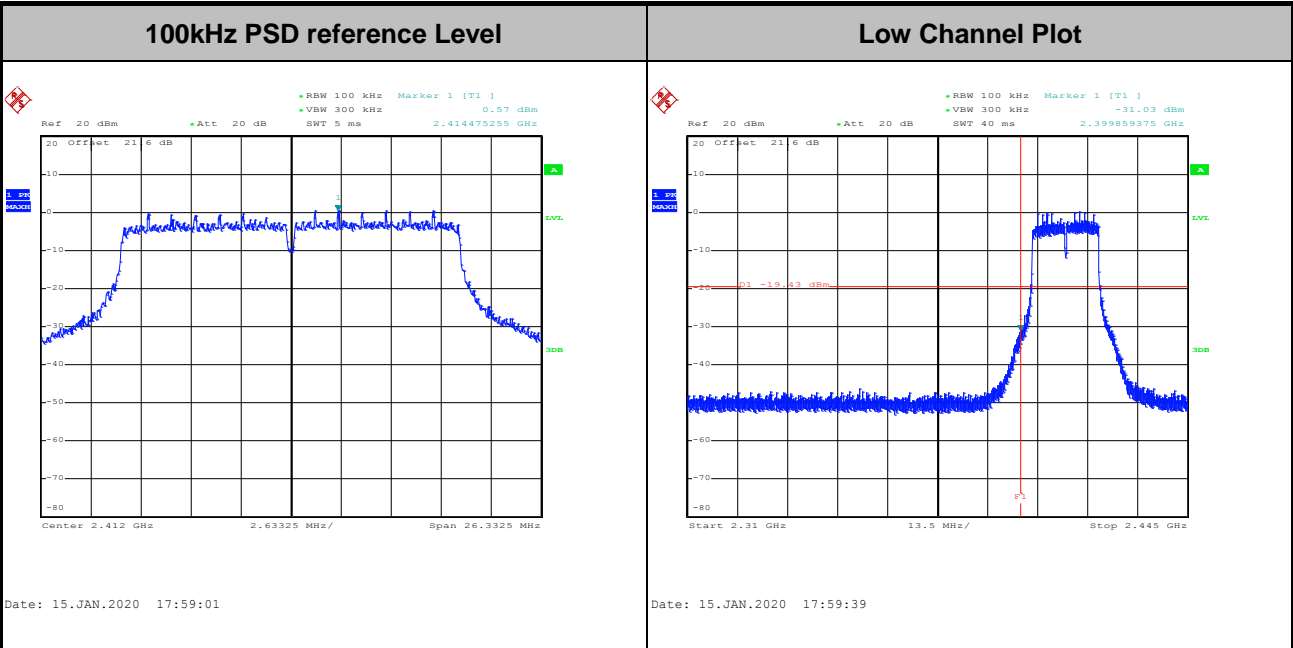



Test Mode :	802.11n HT20	Test Channel :	06
-------------	--------------	----------------	----

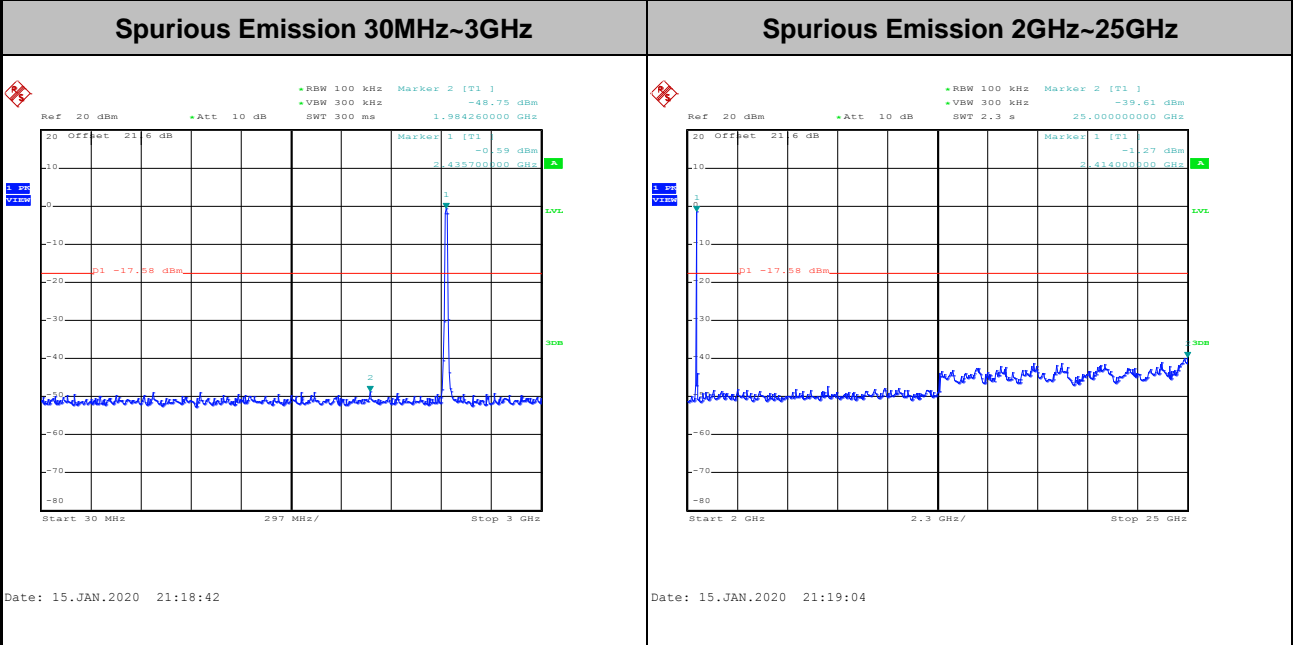
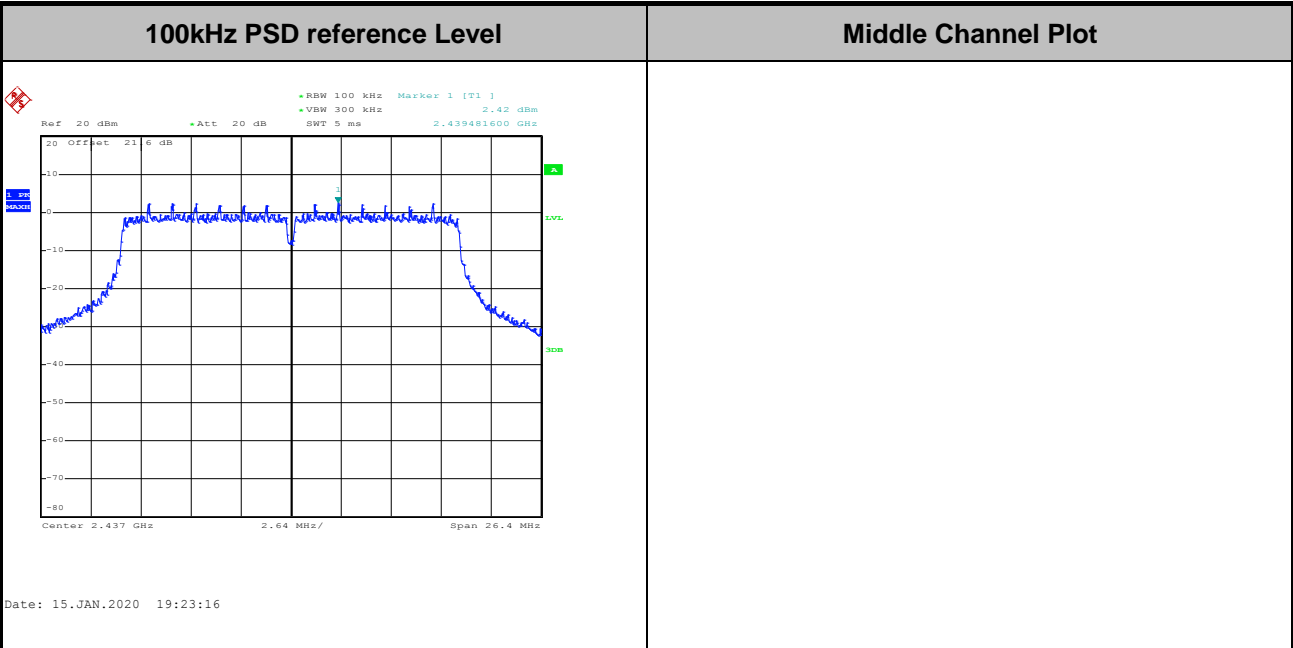



Test Mode :	802.11n HT20	Test Channel :	11
-------------	--------------	----------------	----

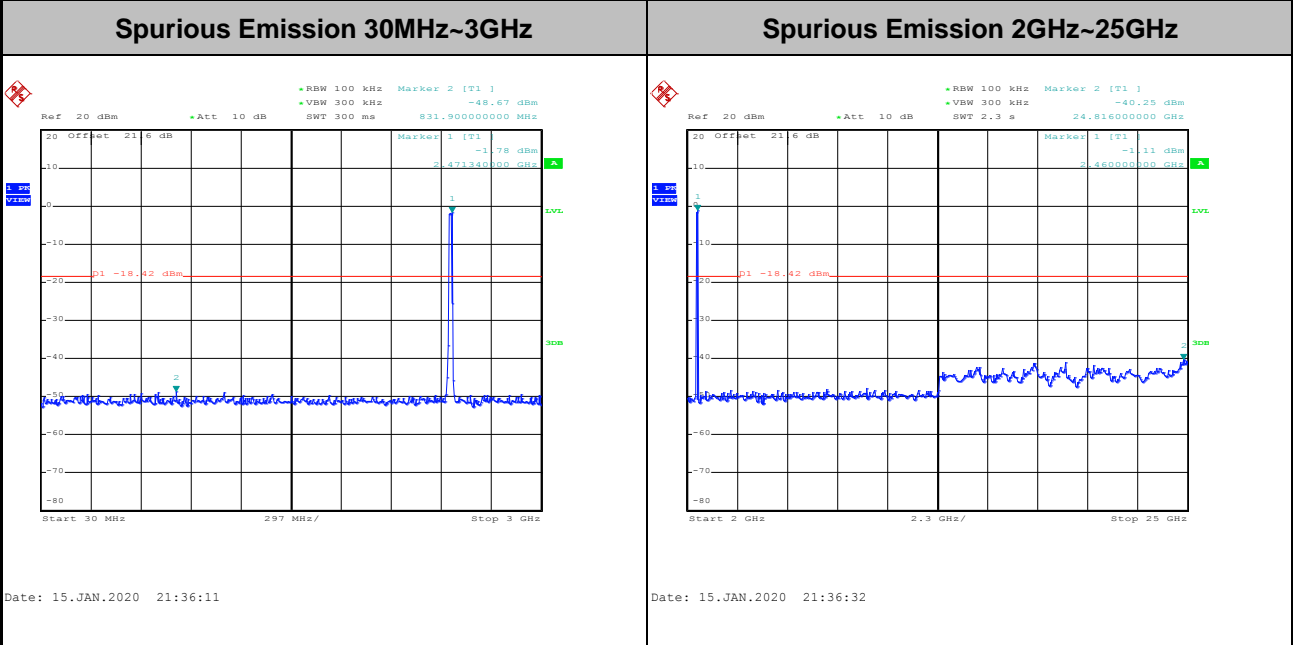
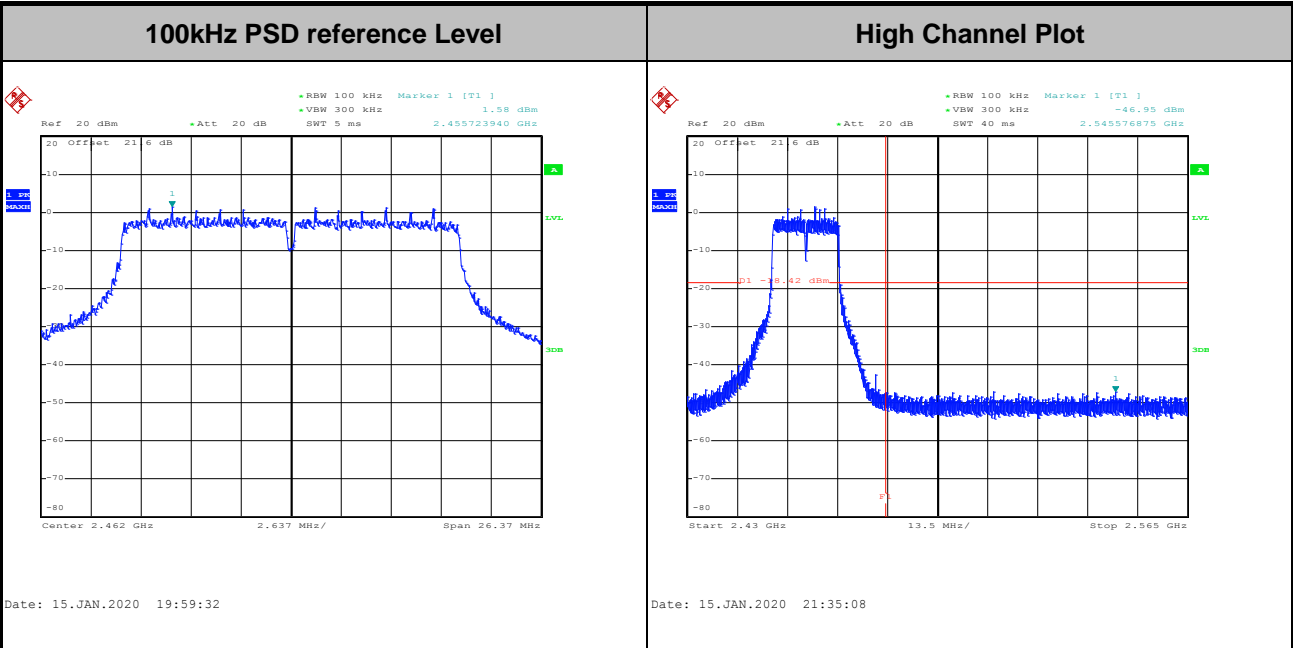



Test Mode :	802.11ax HE20(Full RU)	Test Channel :	01
--------------------	------------------------	-----------------------	----

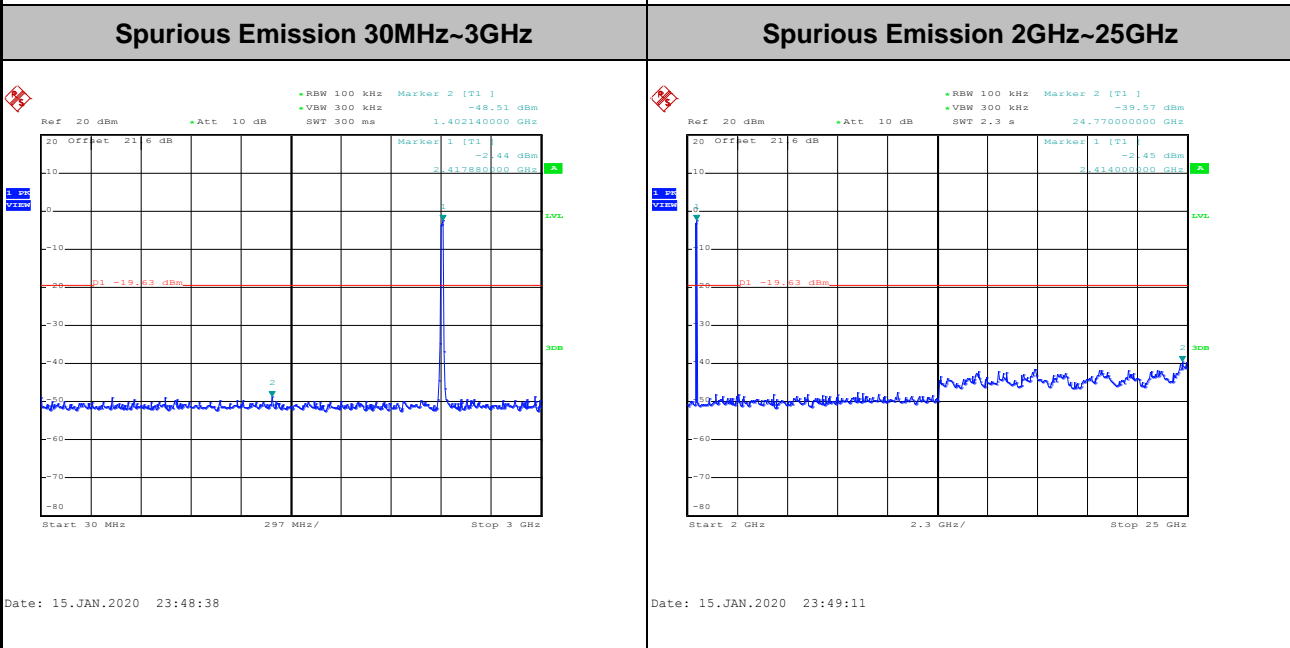
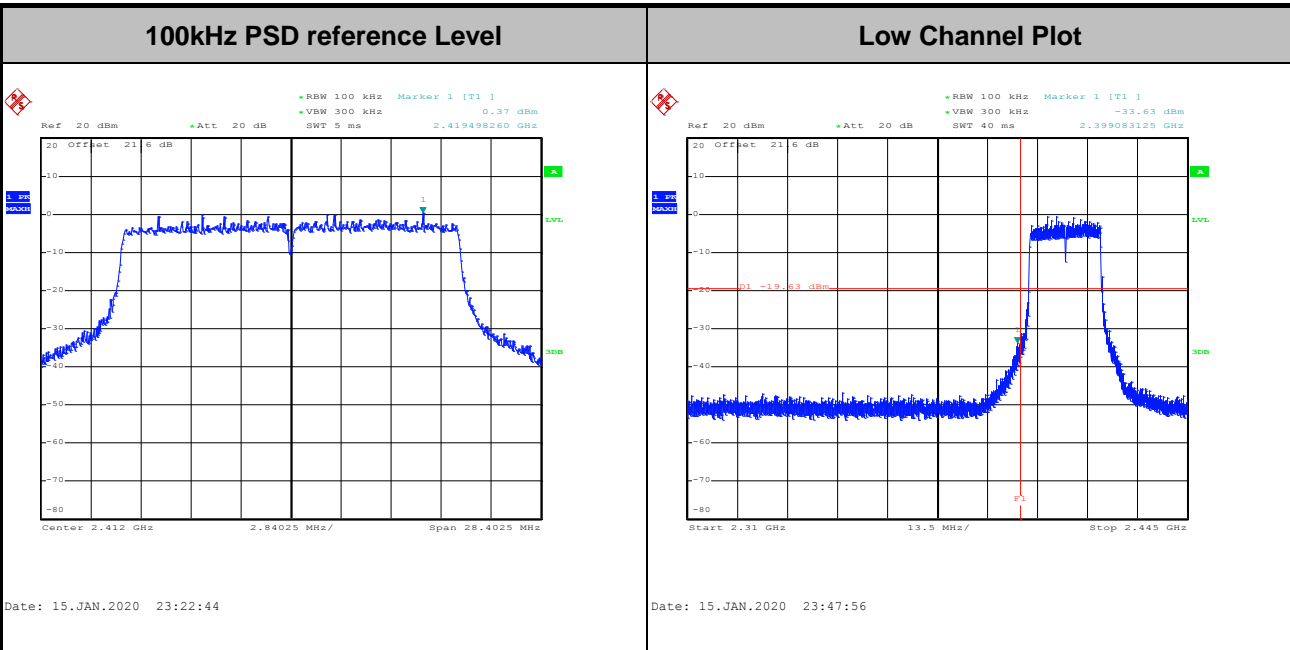



Test Mode :	802.11ax HE20(Full RU)	Test Channel :	06
-------------	------------------------	----------------	----

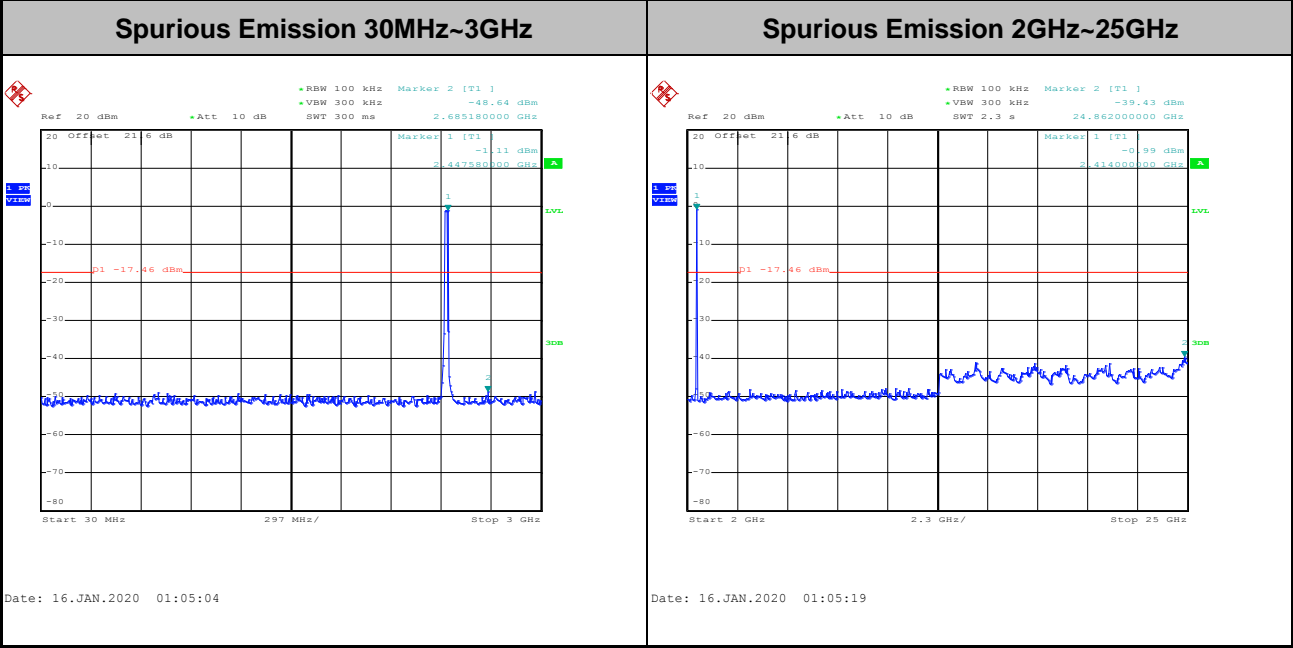
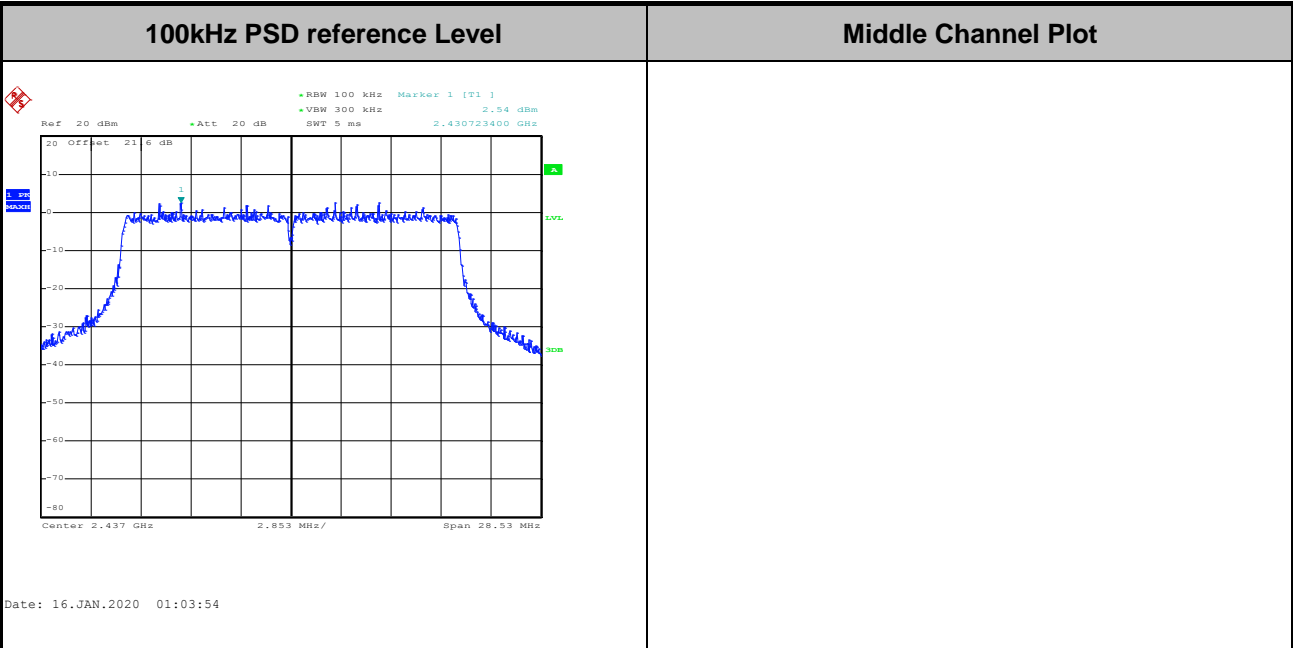



Test Mode :	802.11ax HE20(Full RU)	Test Channel :	11
--------------------	------------------------	-----------------------	----

100kHz PSD reference Level	High Channel Plot
-----------------------------------	--------------------------

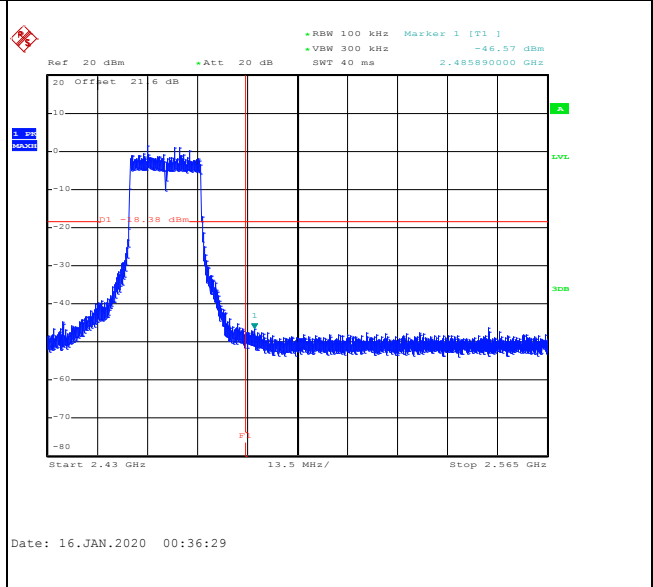
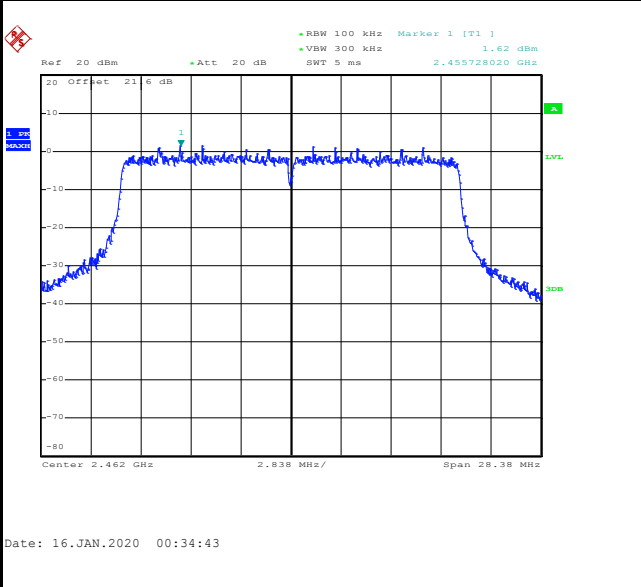

Spurious Emission 30MHz~3GHz	Spurious Emission 2GHz~25GHz
-------------------------------------	-------------------------------------

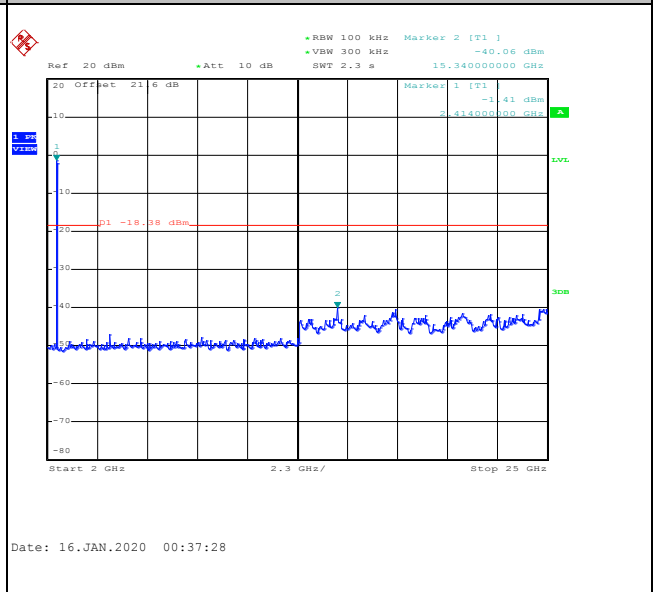
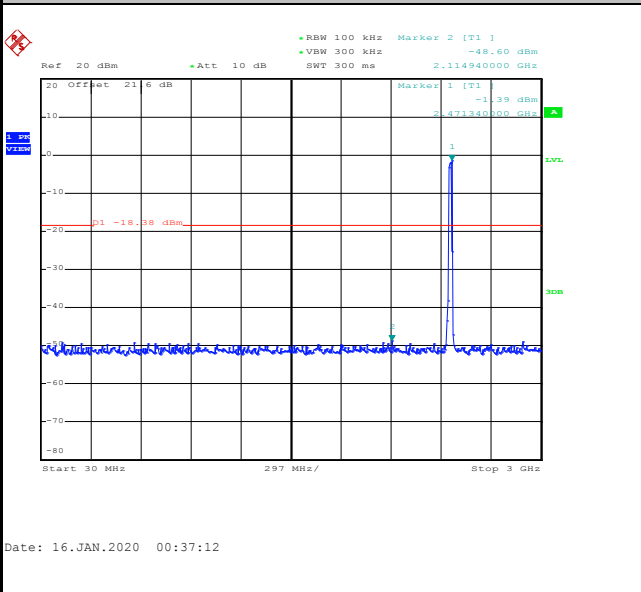



Test Mode :	802.11ax HE20(Partial RU 26/0)	Test Channel :	01
-------------	--------------------------------	----------------	----

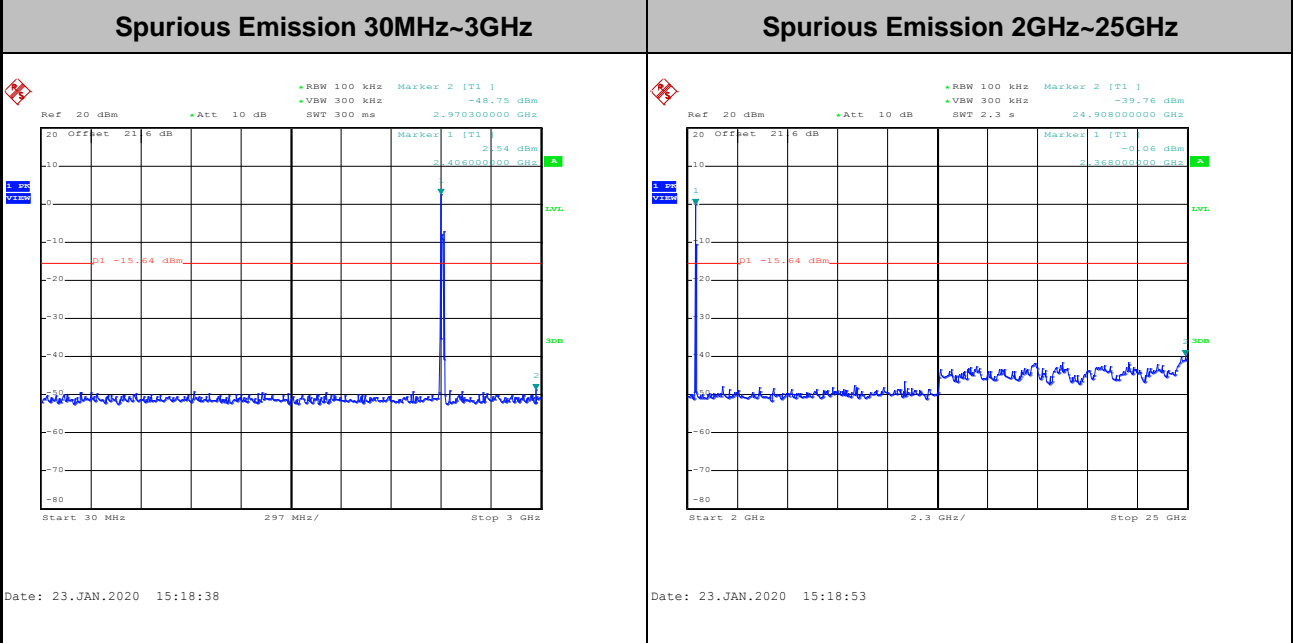
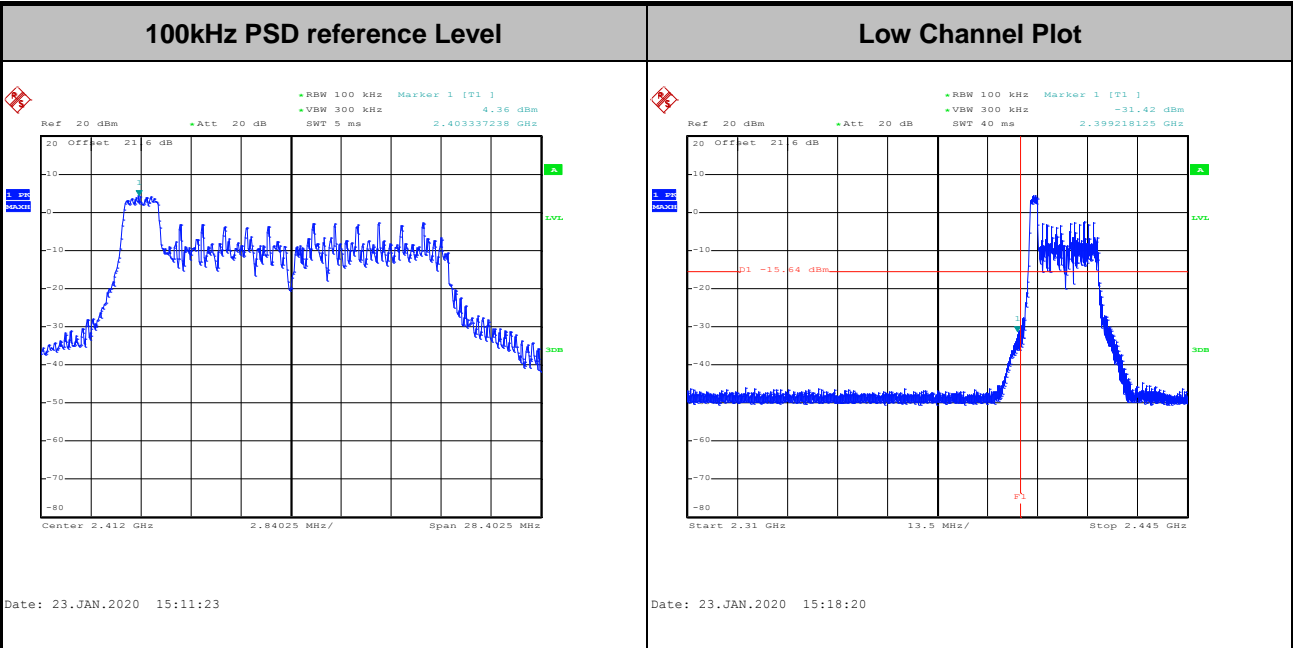



Test Mode :	802.11ax HE20(Partial RU 26/8)	Test Channel :	11
--------------------	--------------------------------	-----------------------	----

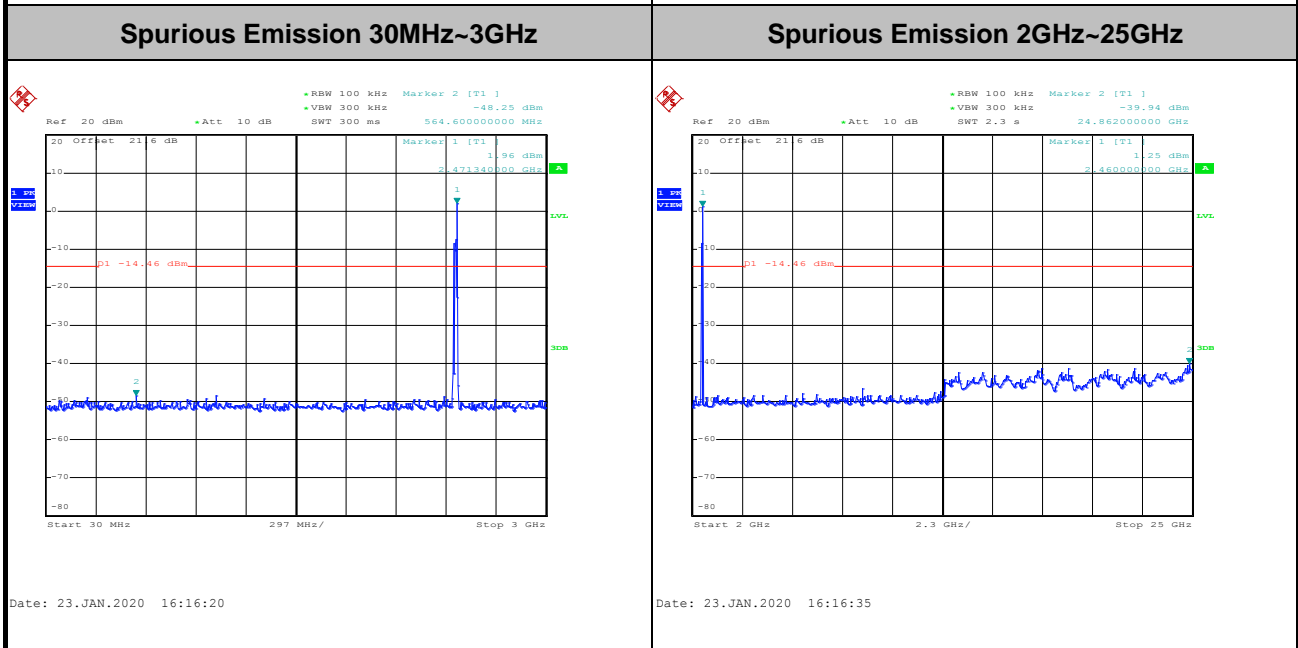
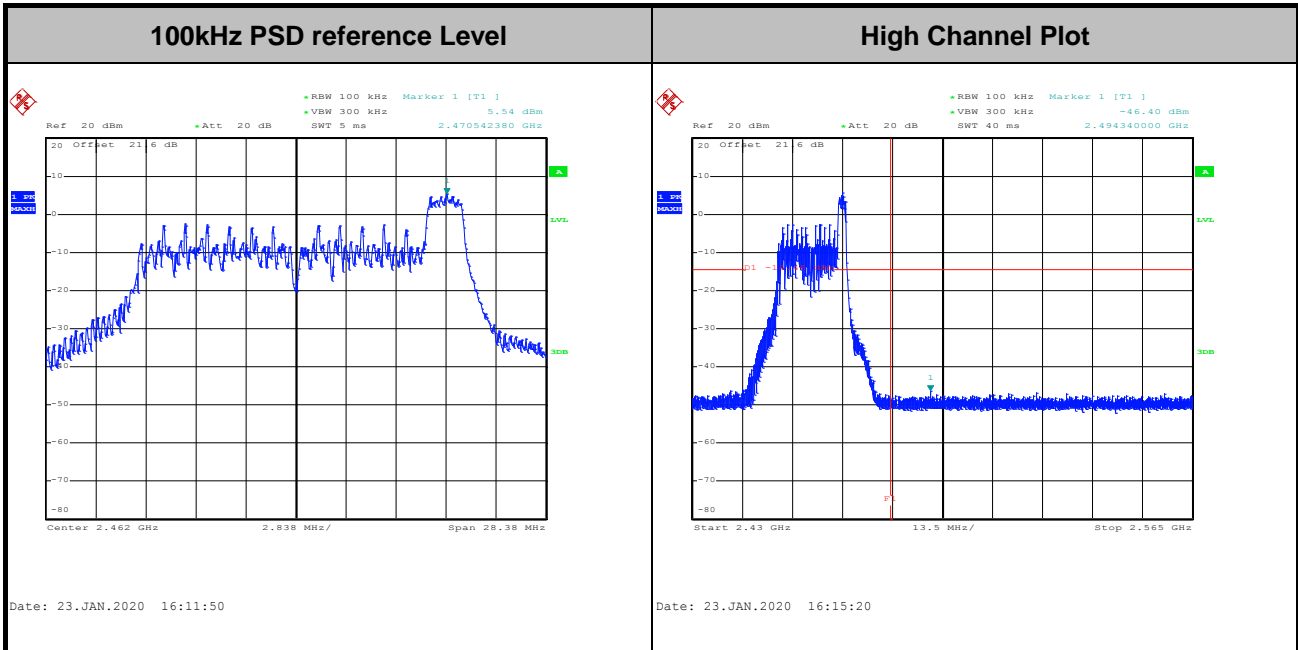



Test Mode :	802.11ax HE20(Partial RU 52/37)	Test Channel :	01
-------------	---------------------------------	----------------	----

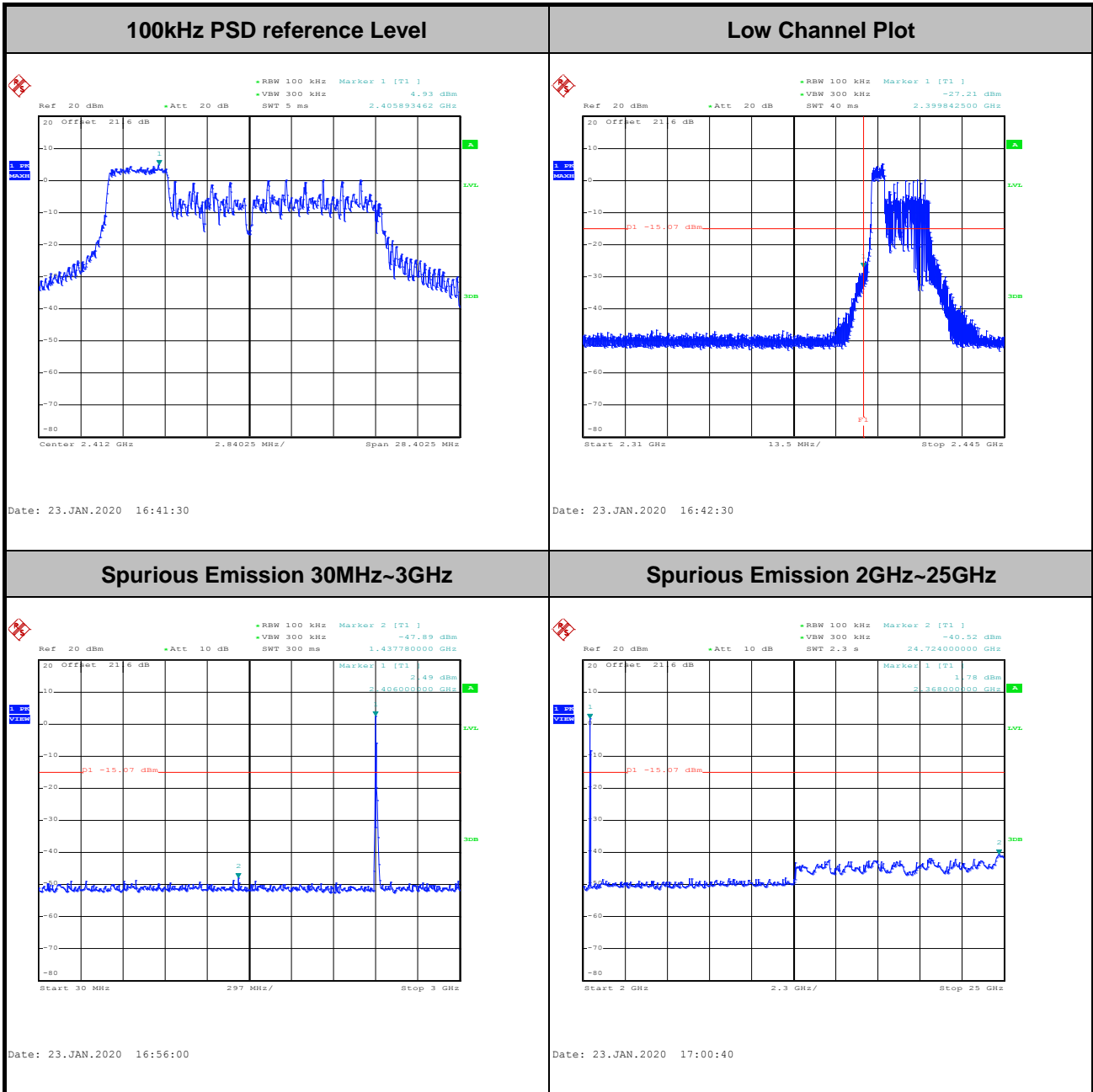



Test Mode :	802.11ax HE20(Partial RU 52/40)	Test Channel :	11
--------------------	---------------------------------	-----------------------	----

100kHz PSD reference Level	High Channel Plot
-----------------------------------	--------------------------

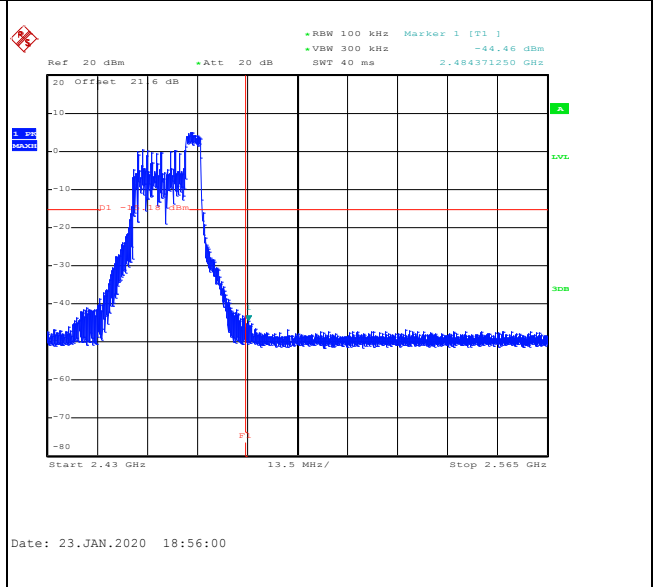
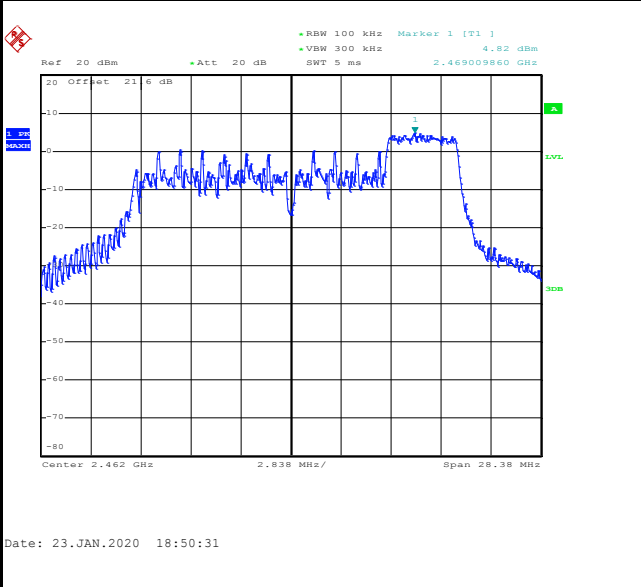

Spurious Emission 30MHz~3GHz	Spurious Emission 2GHz~25GHz
-------------------------------------	-------------------------------------

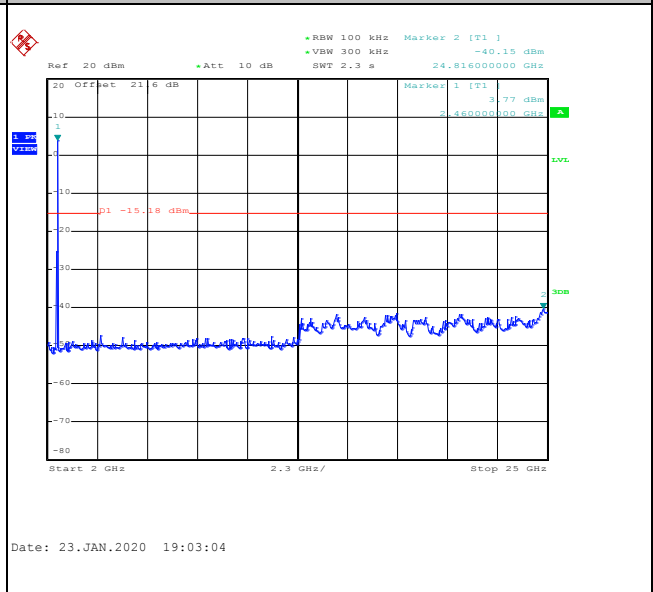
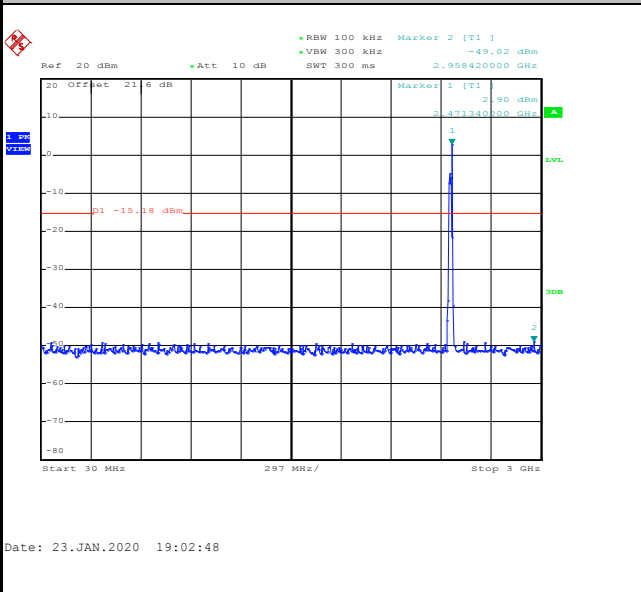



Test Mode :	802.11ax HE20(Partial RU 106/53)	Test Channel :	01
-------------	----------------------------------	----------------	----

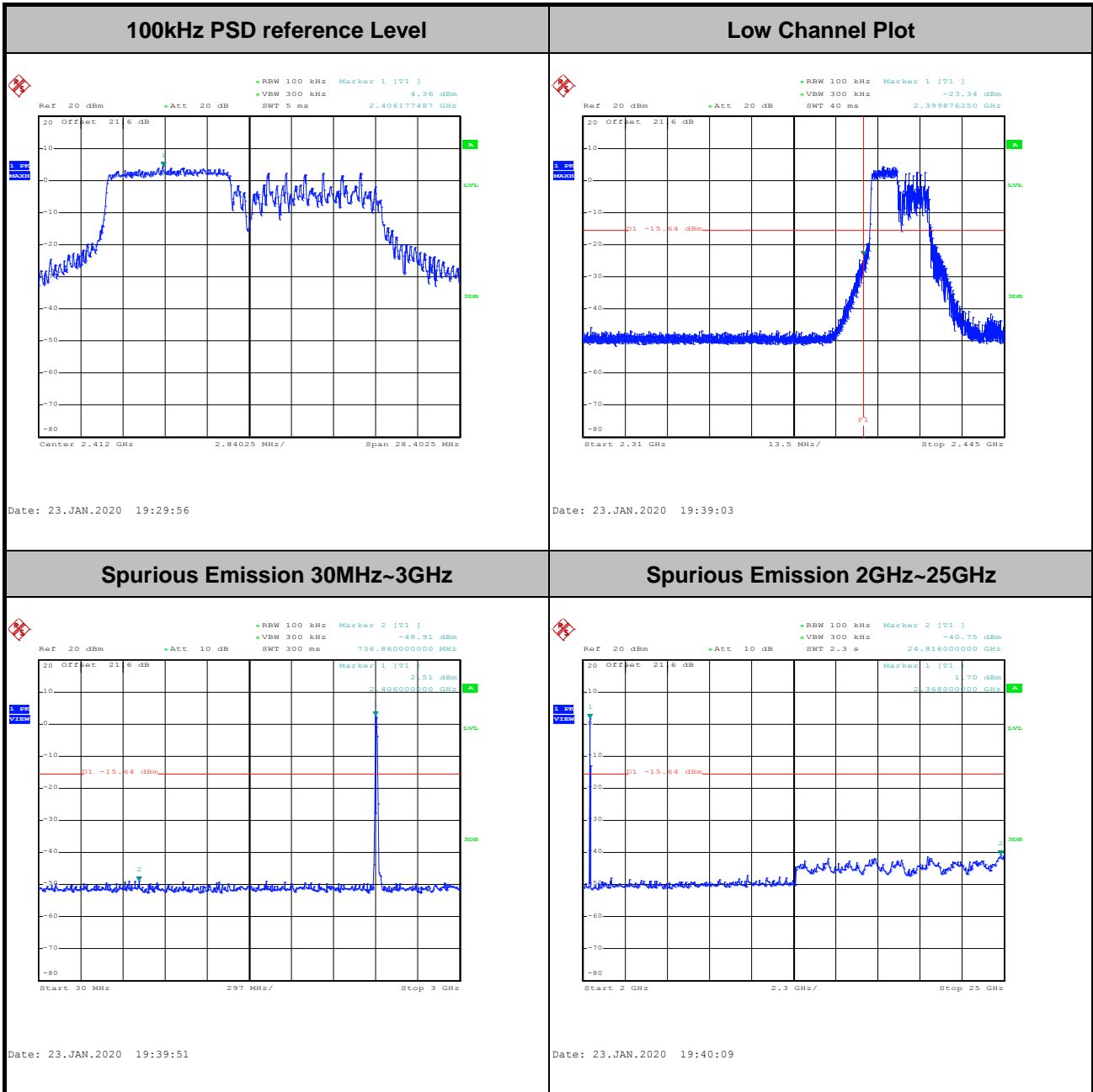



Test Mode :	802.11ax HE20(Partial RU 106/54)	Test Channel :	11
-------------	----------------------------------	----------------	----

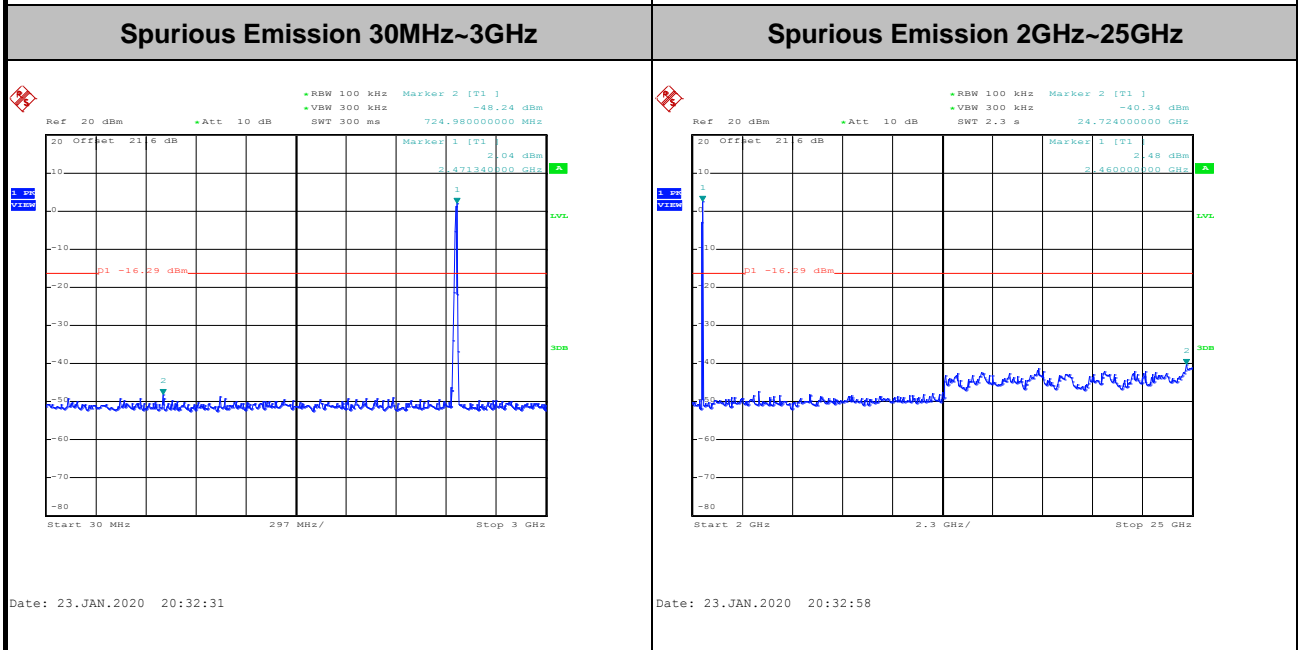
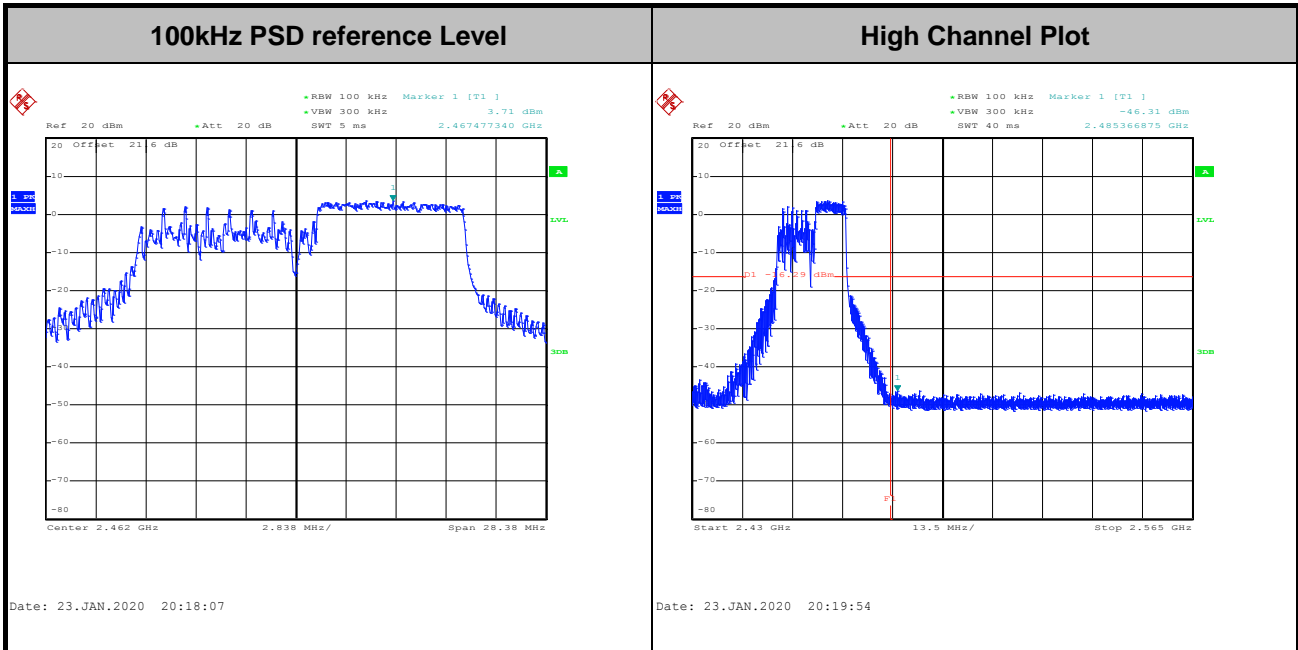



Number of TX = 2, Ant. 2 (Measured)

Test Mode :	802.11b	Test Channel :	01
-------------	---------	----------------	----

100kHz PSD reference Level	Low Channel Plot
-----------------------------------	-------------------------

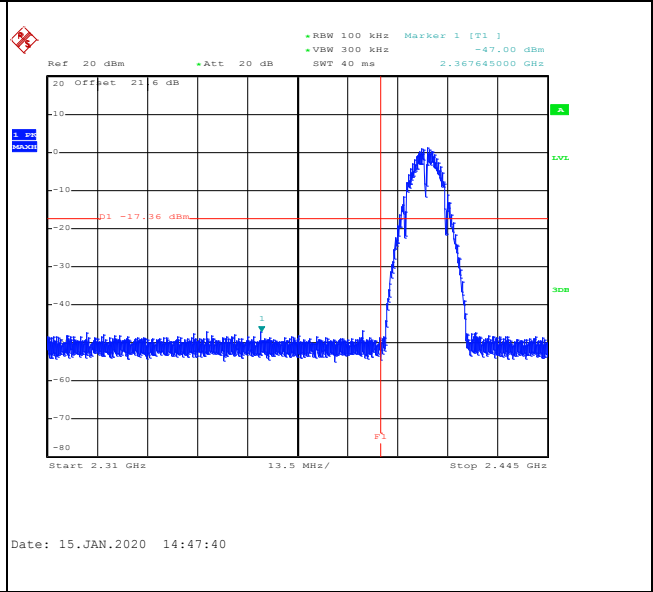
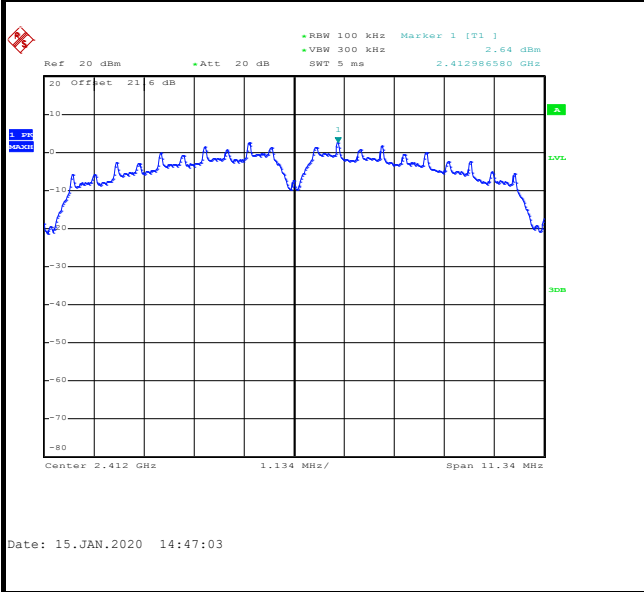

Spurious Emission 30MHz~3GHz	Spurious Emission 2GHz~25GHz
-------------------------------------	-------------------------------------

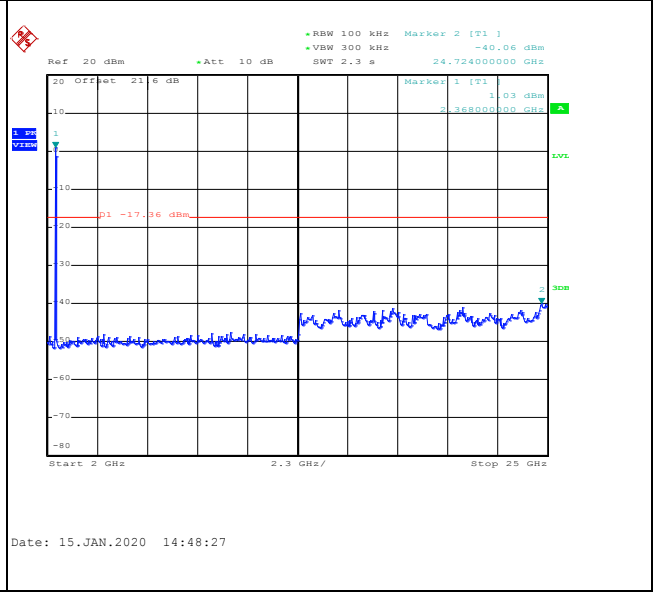
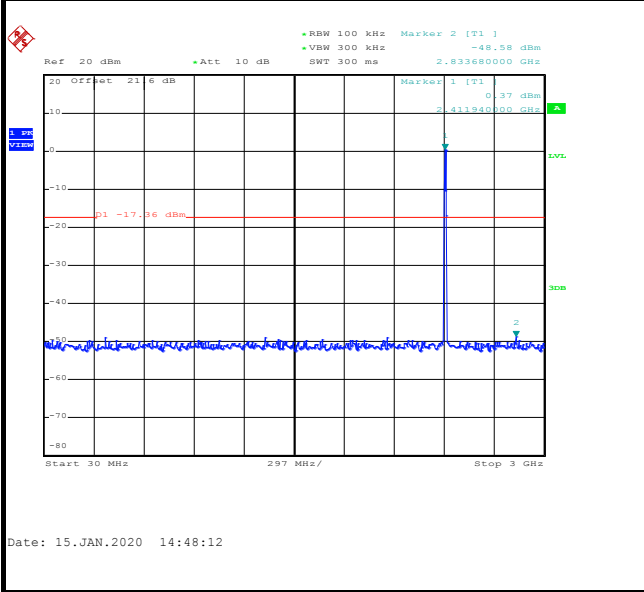



Test Mode :	802.11b	Test Channel :	06
-------------	---------	----------------	----

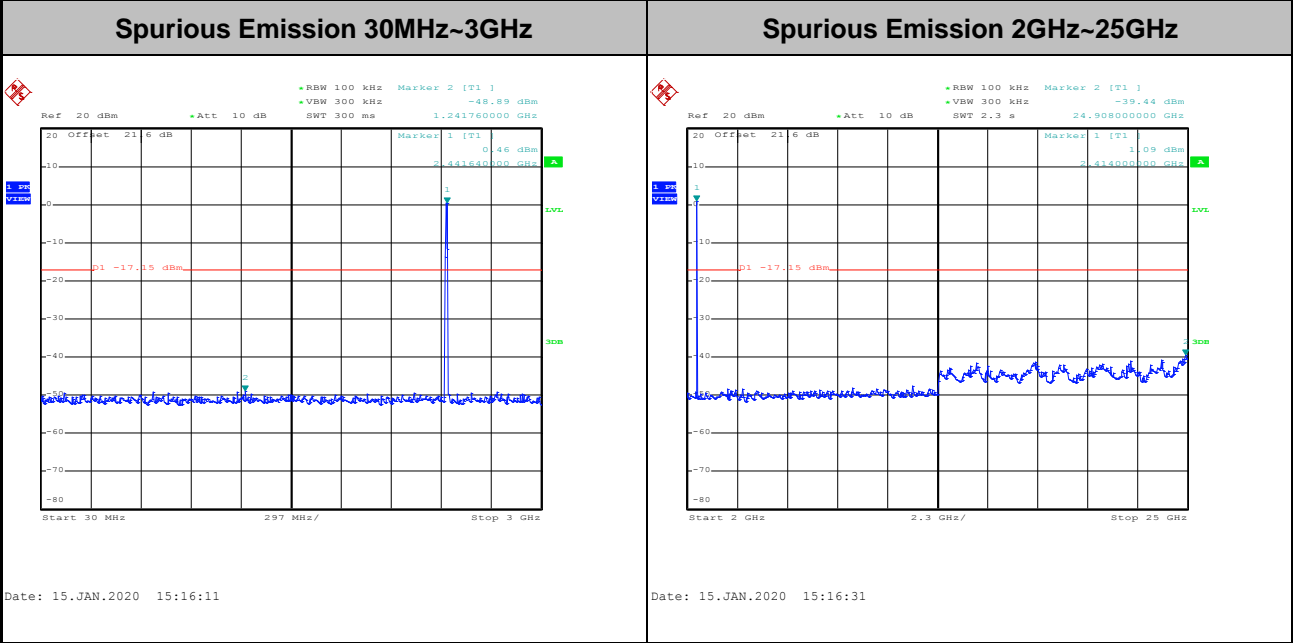
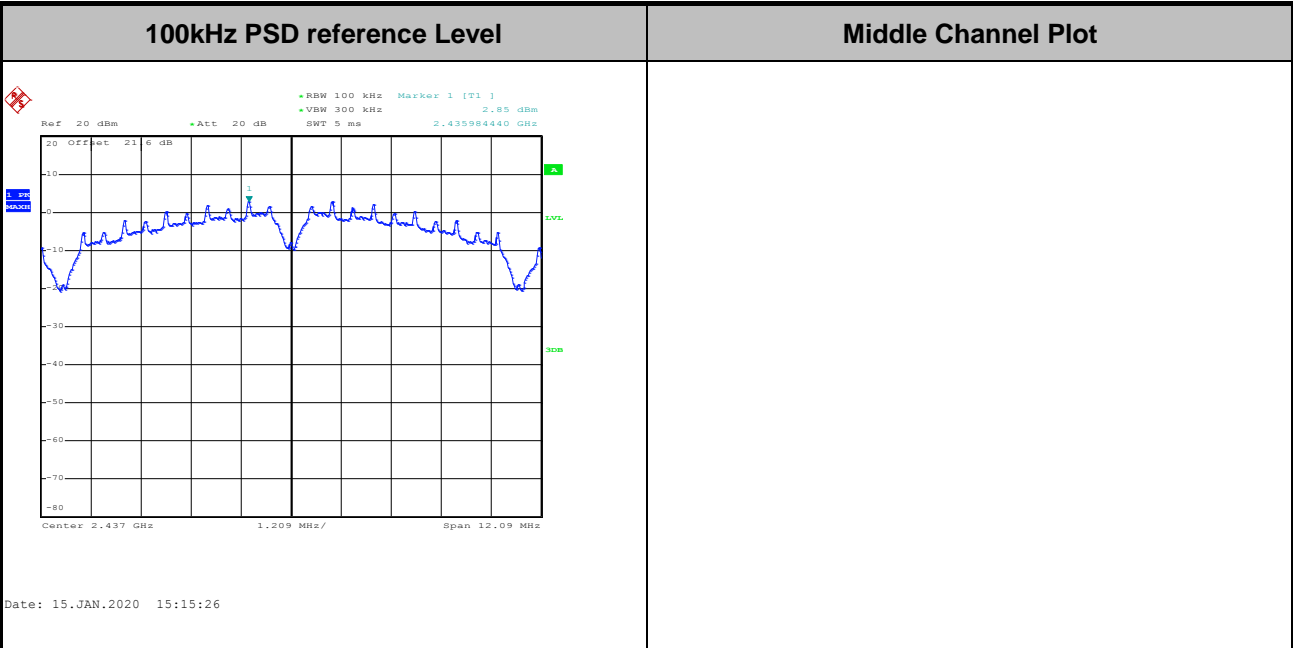



Test Mode :	802.11b	Test Channel :	11
-------------	---------	----------------	----

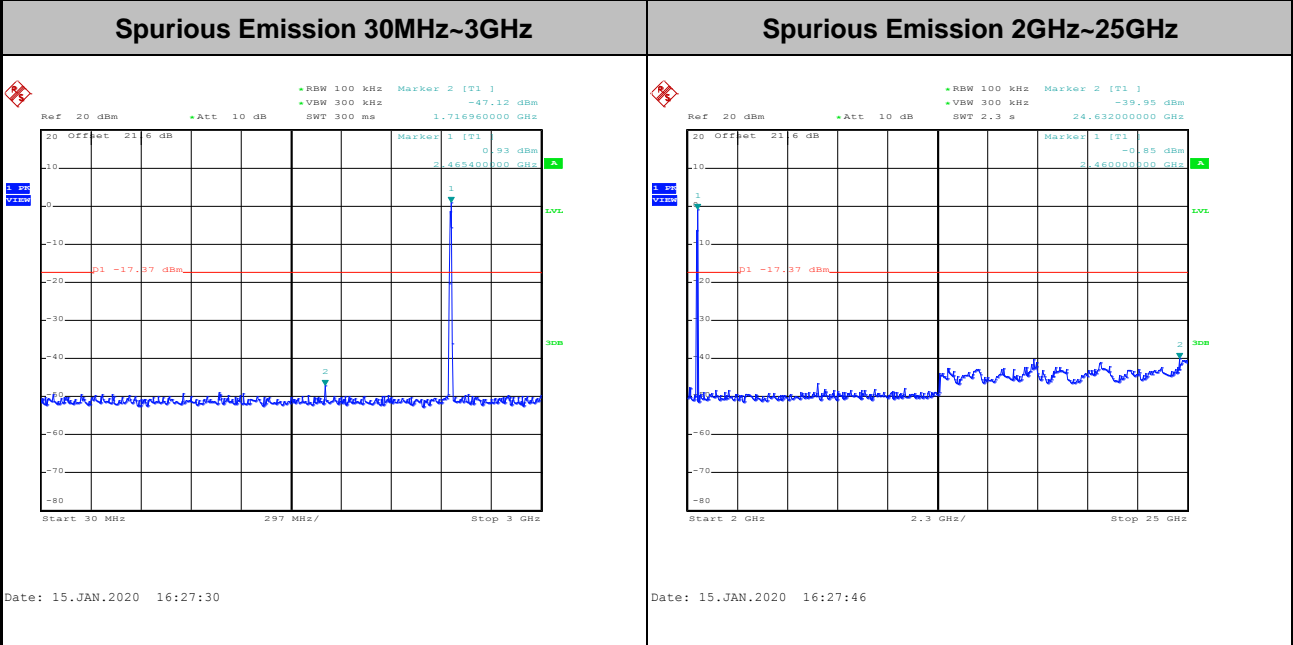
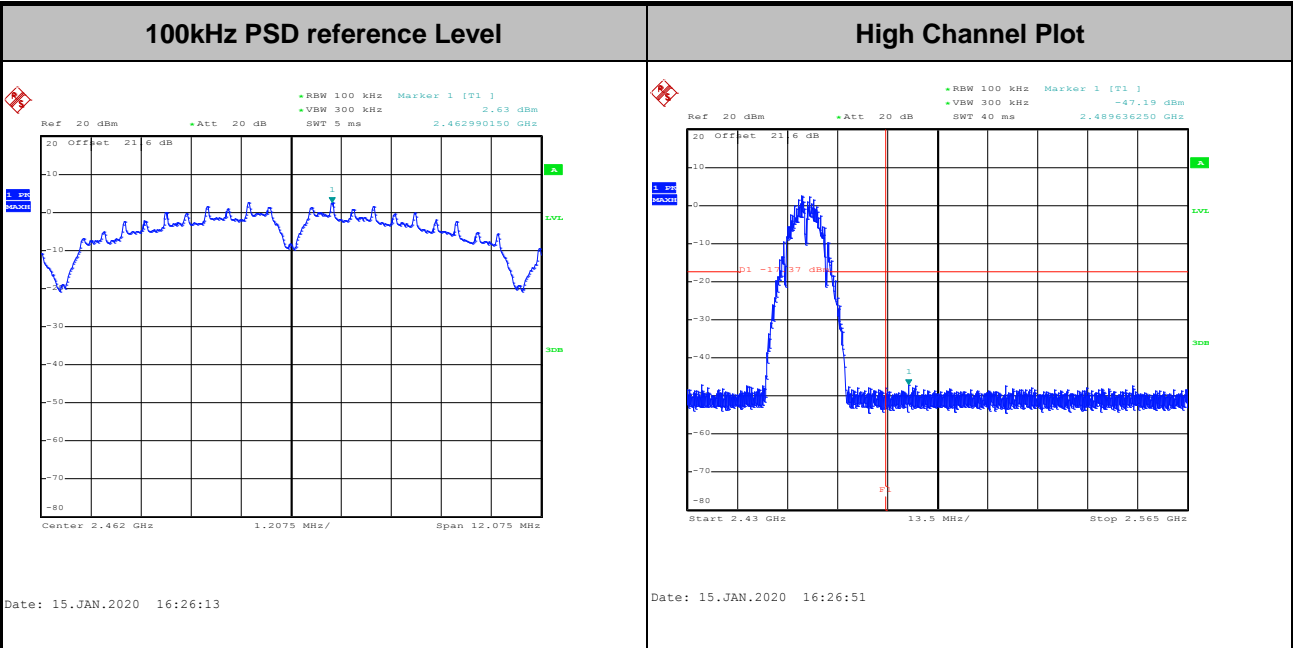



Test Mode :	802.11g	Test Channel :	01
-------------	---------	----------------	----

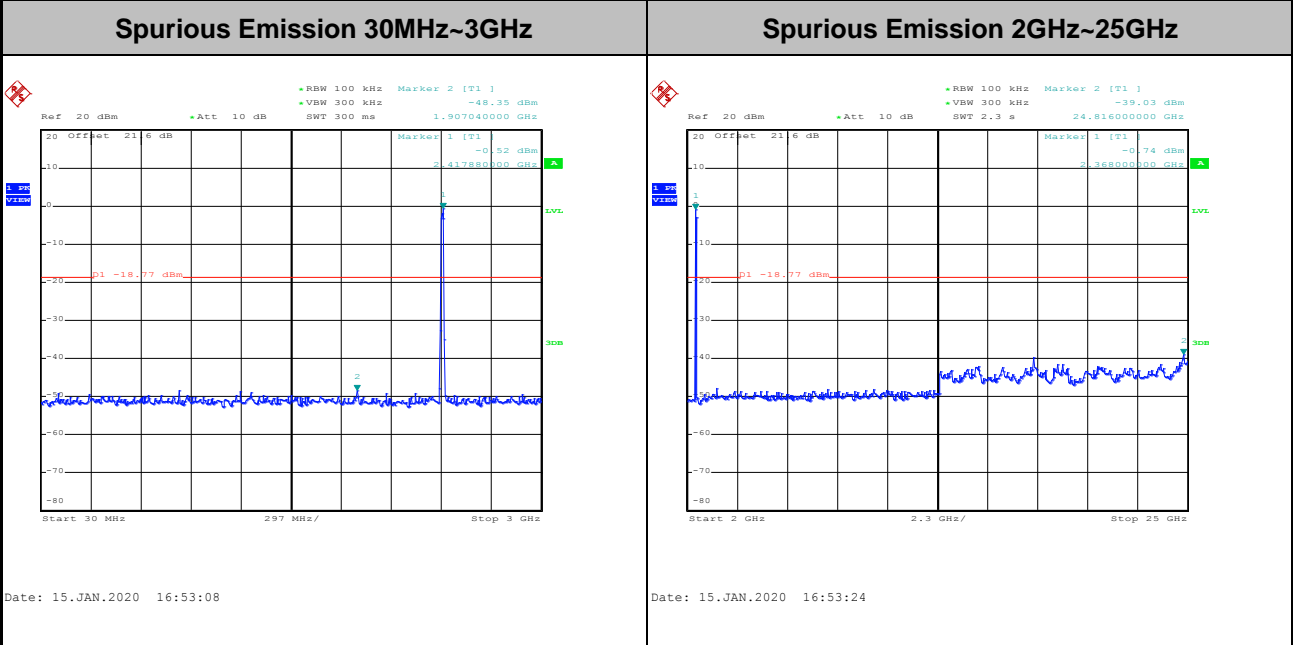
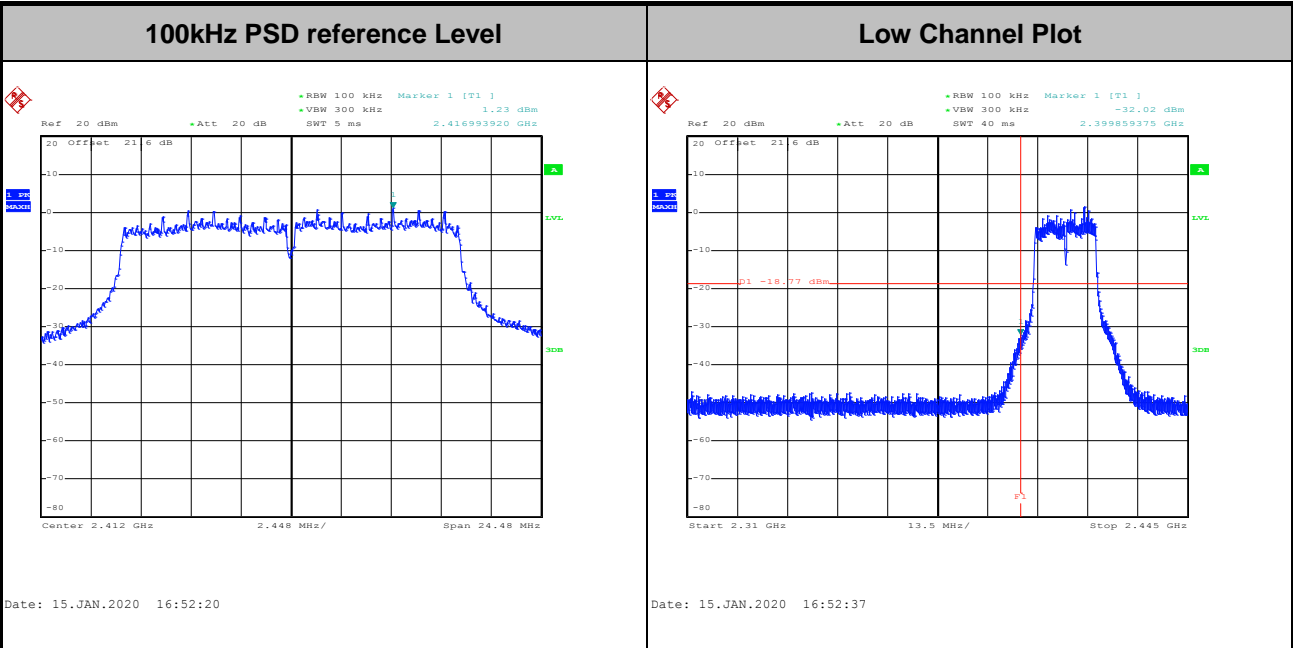



Test Mode :	802.11g	Test Channel :	06
-------------	---------	----------------	----

100kHz PSD reference Level	Middle Channel Plot
-----------------------------------	----------------------------

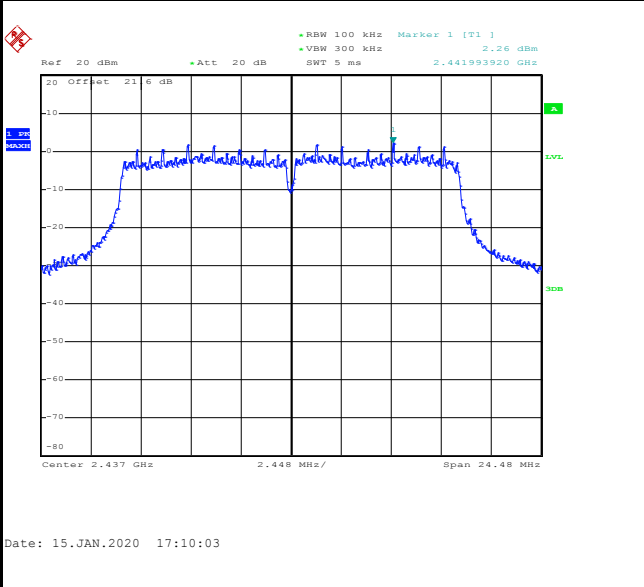

Spurious Emission 30MHz~3GHz	Spurious Emission 2GHz~25GHz
-------------------------------------	-------------------------------------

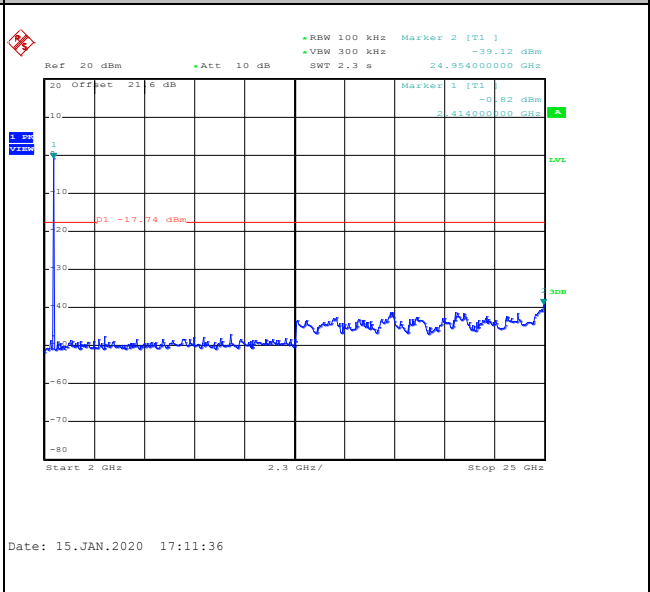
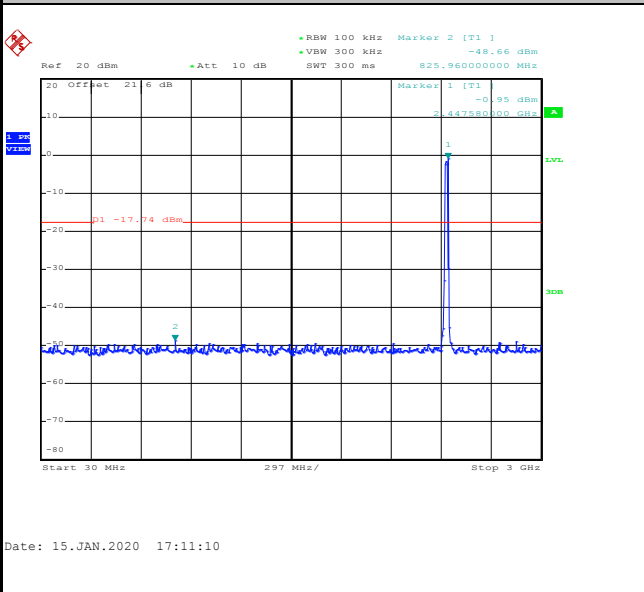



Test Mode :	802.11g	Test Channel :	11
-------------	---------	----------------	----

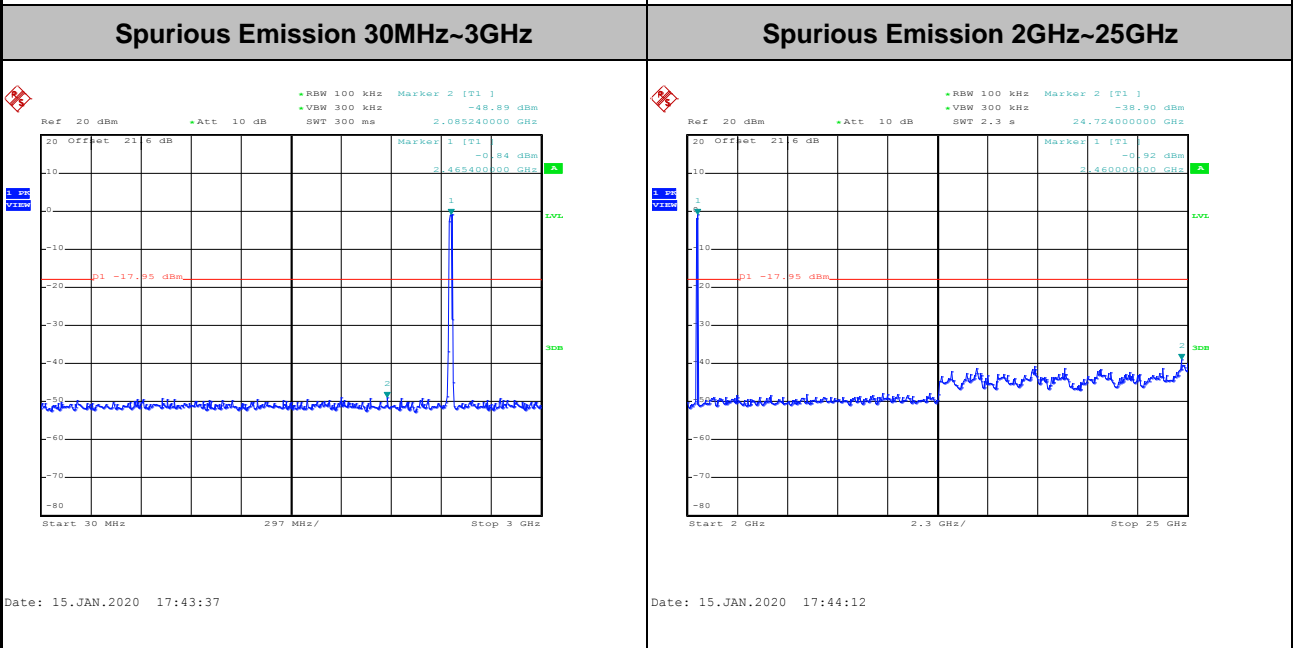
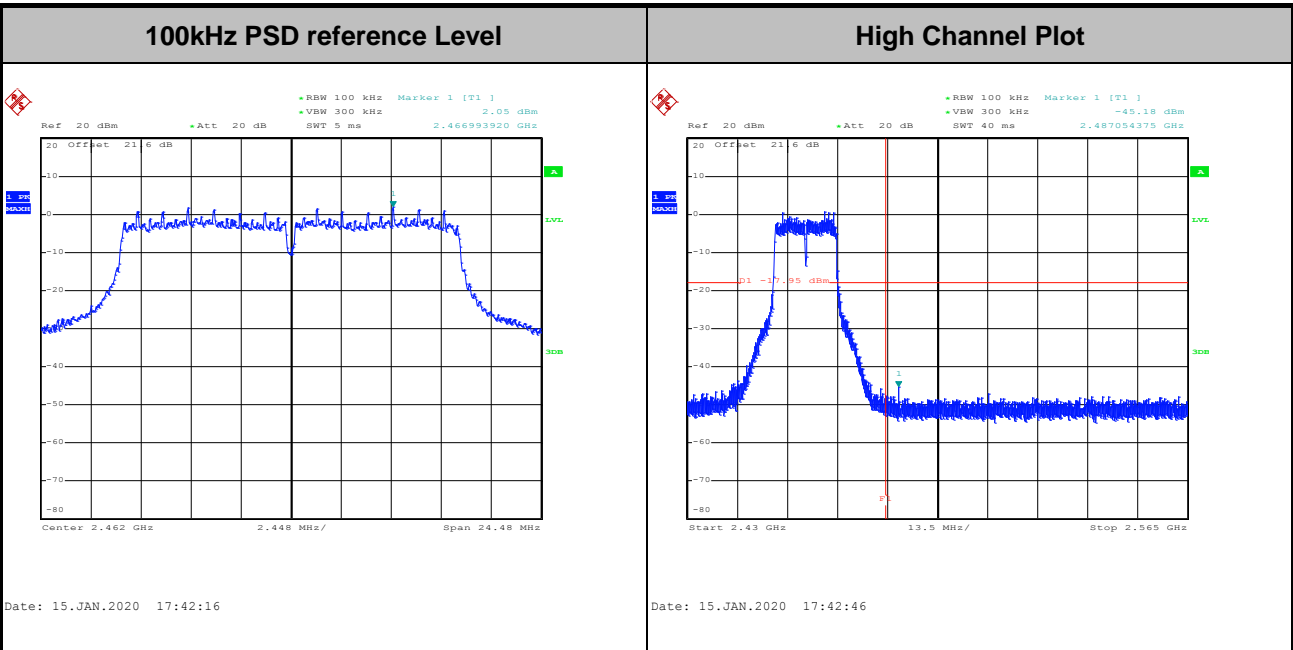



Test Mode :	802.11n HT20	Test Channel :	01
-------------	--------------	----------------	----

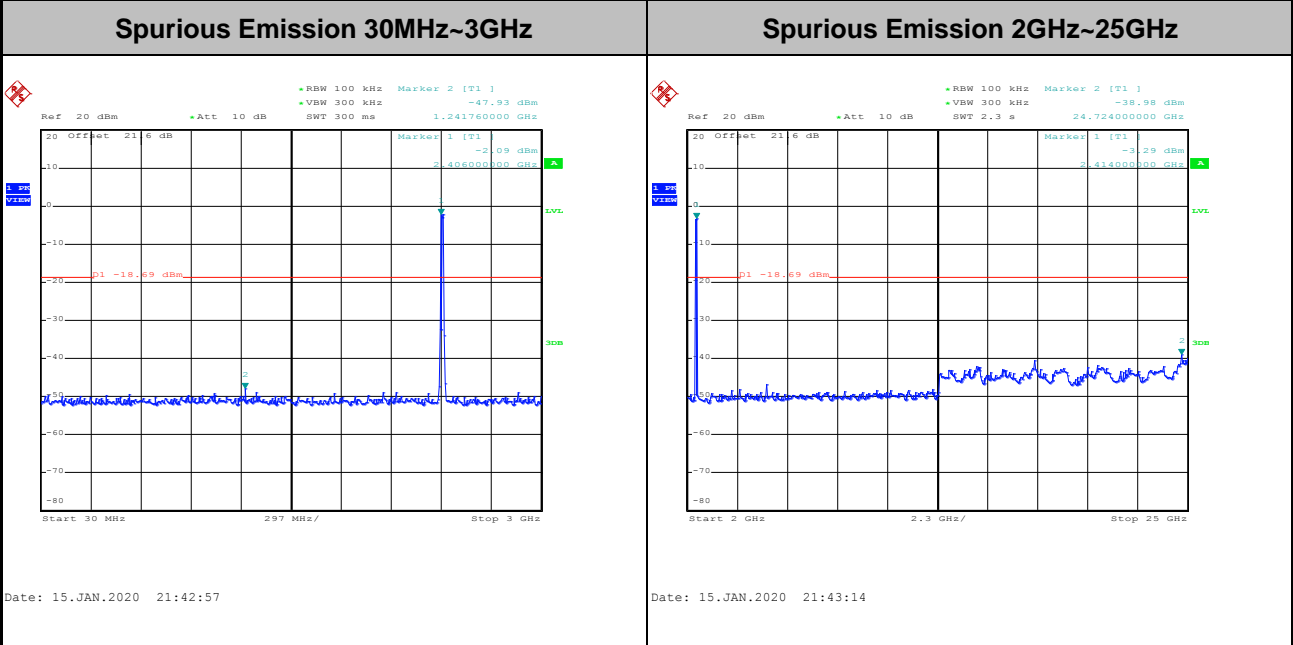
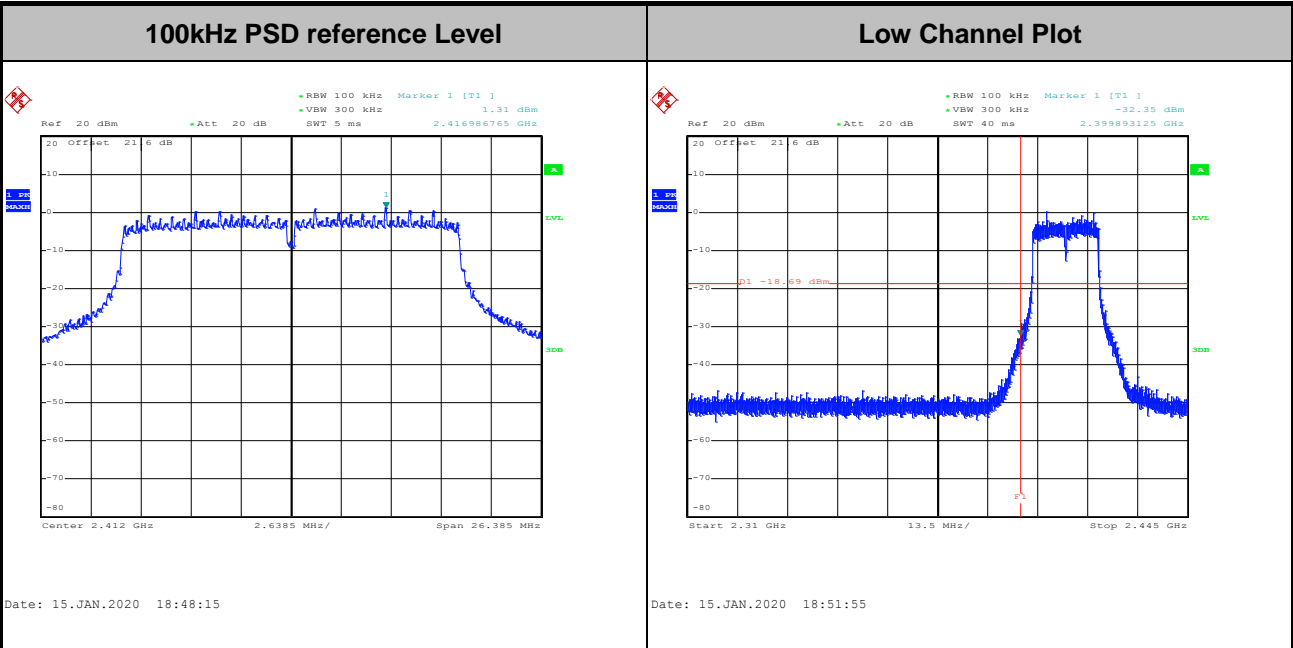



Test Mode :	802.11n HT20	Test Channel :	06
-------------	--------------	----------------	----

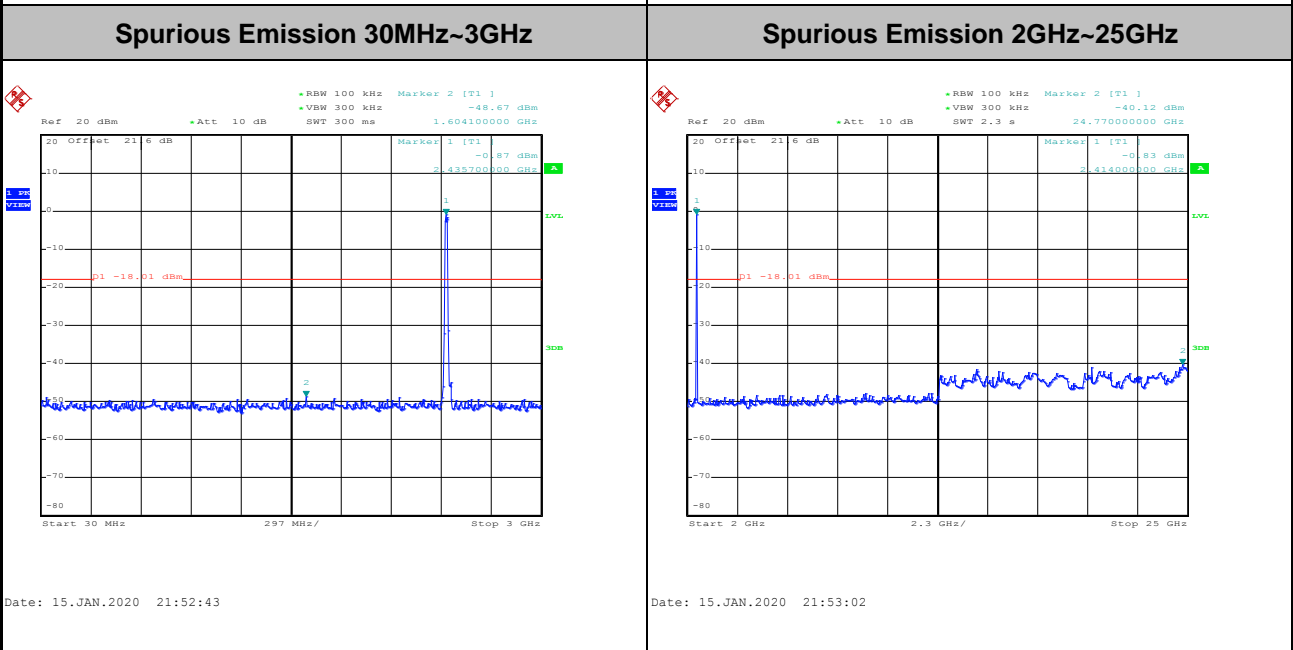
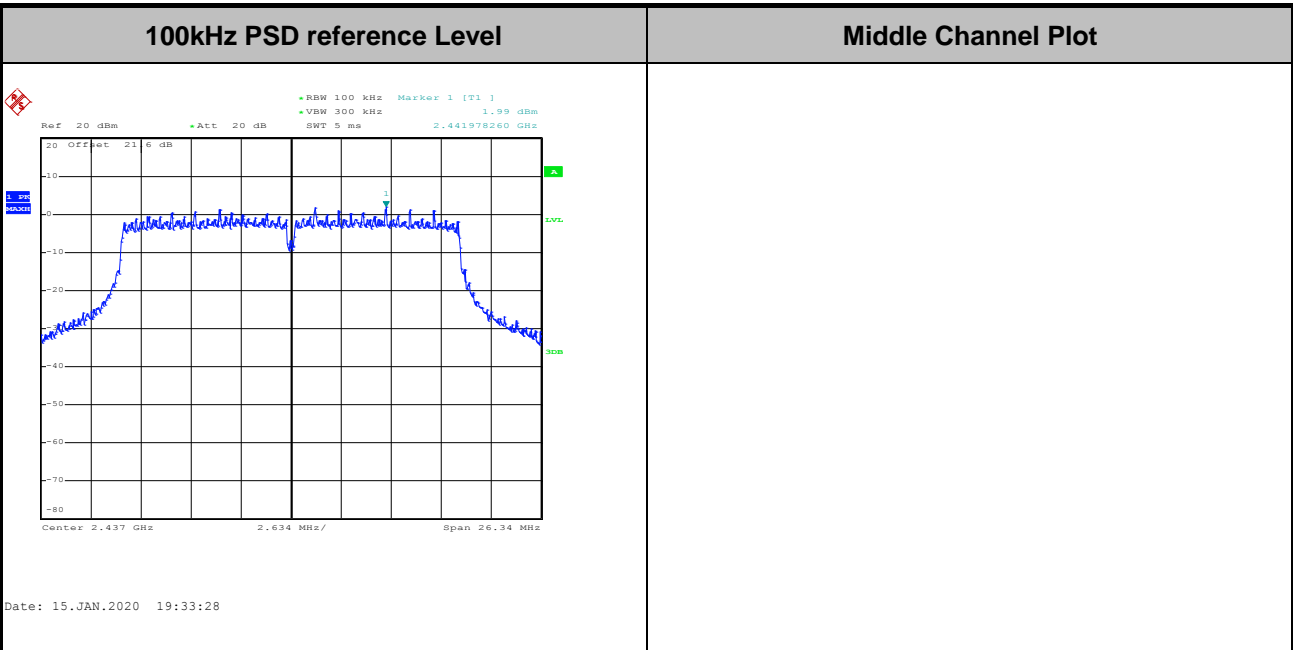



Test Mode :	802.11n HT20	Test Channel :	11
--------------------	--------------	-----------------------	----

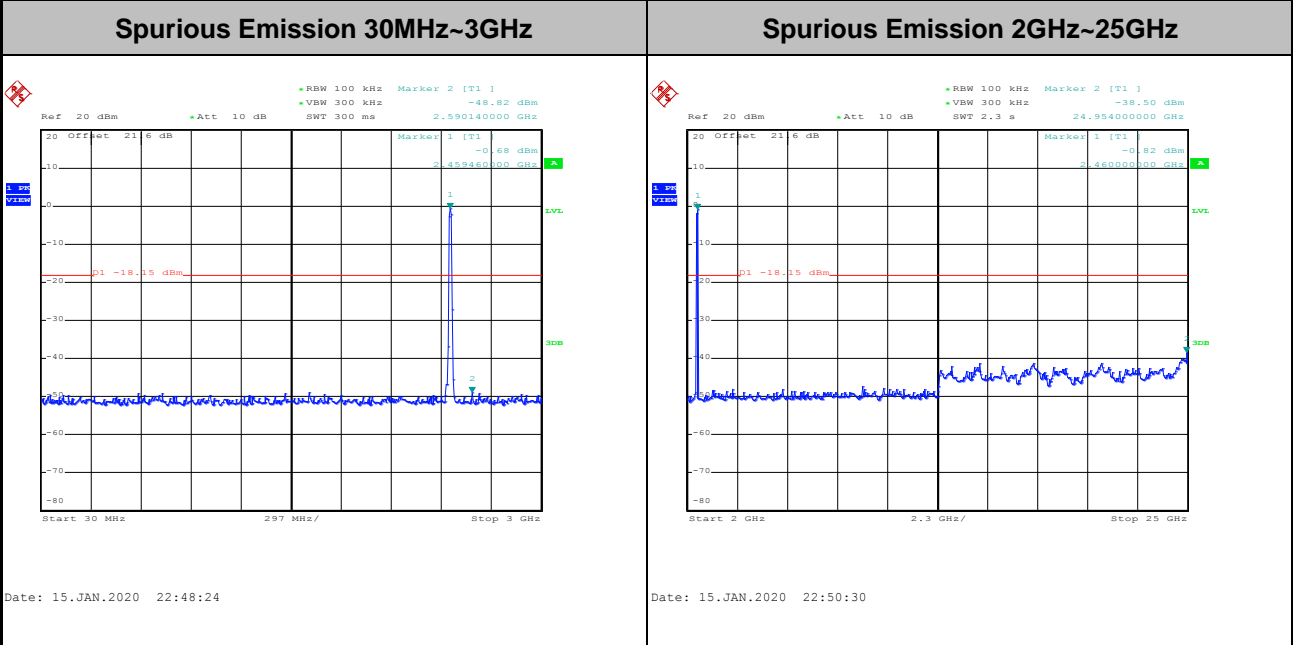
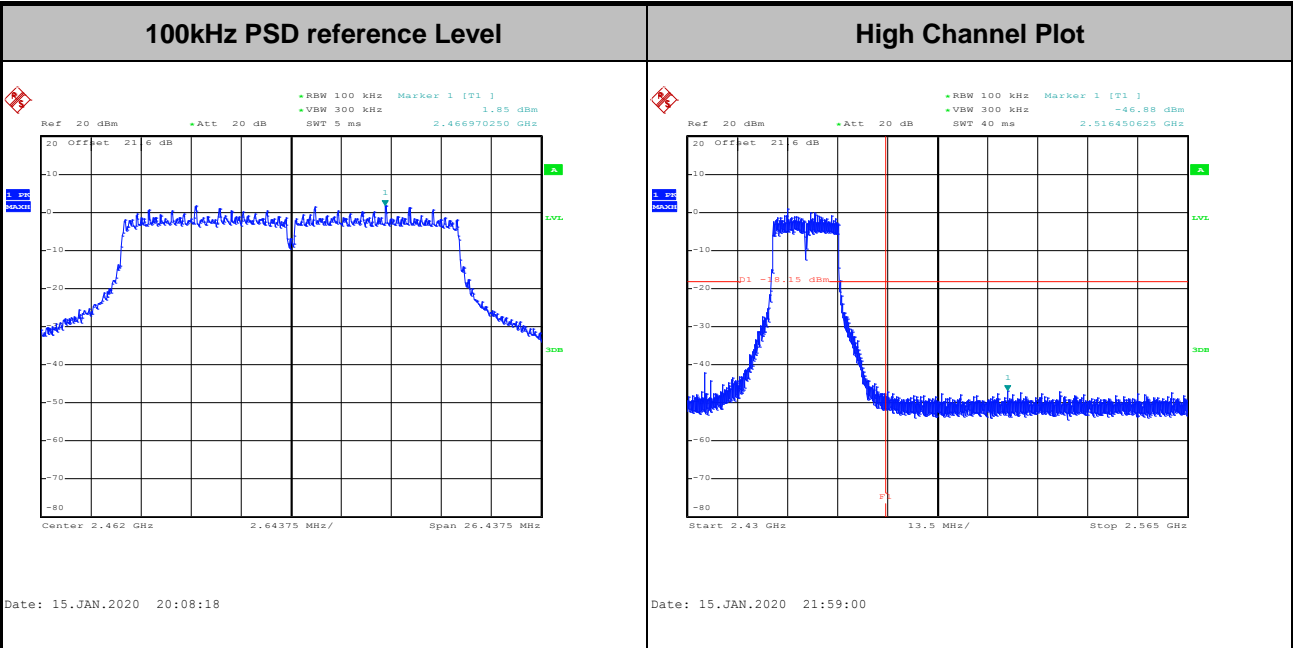



Test Mode :	802.11ax HE20(Full RU)	Test Channel :	01
-------------	------------------------	----------------	----

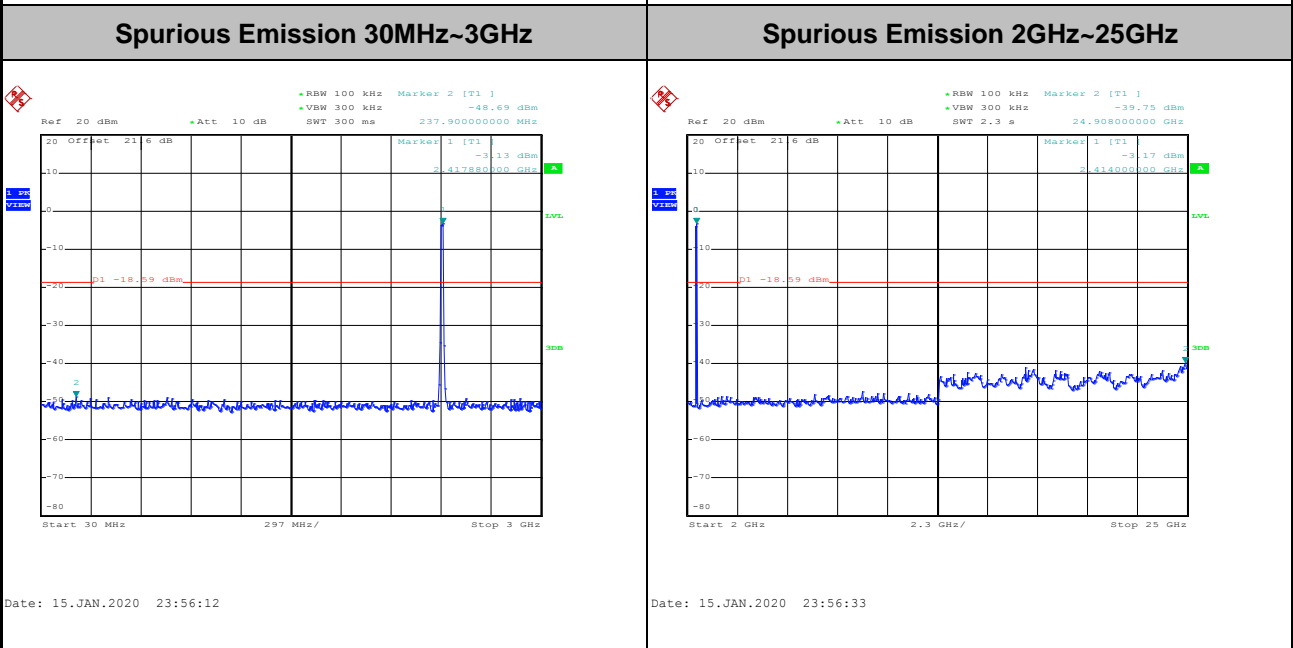
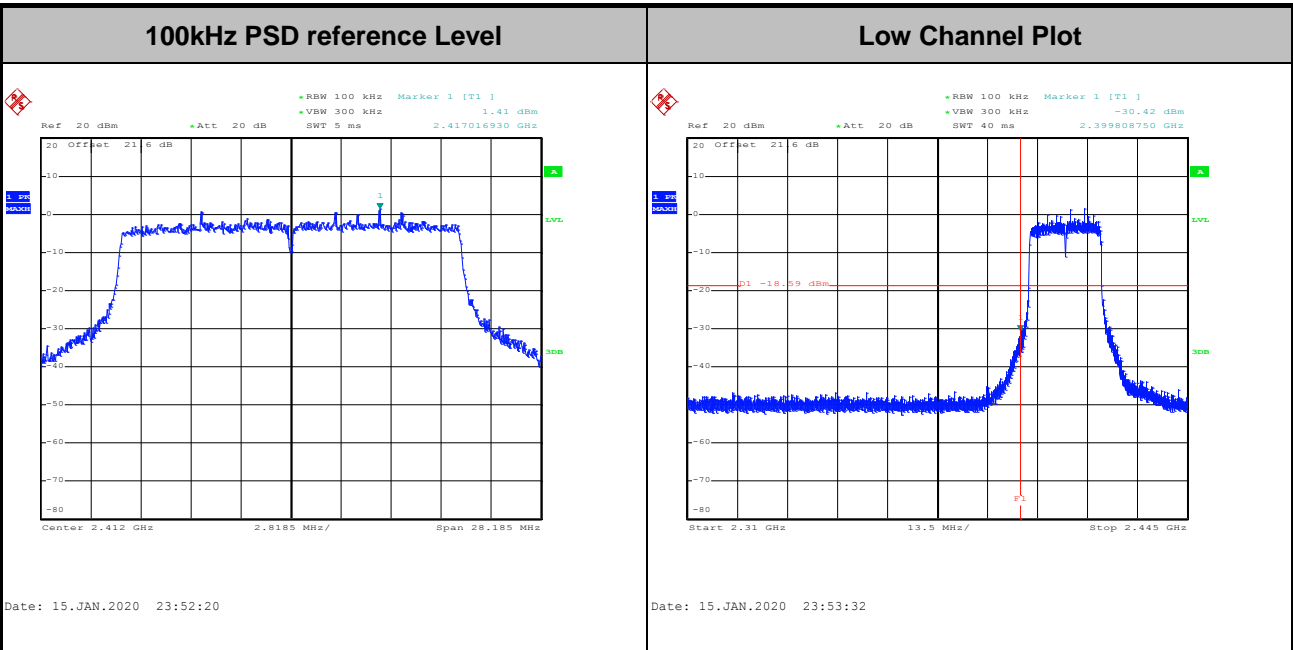



Test Mode :	802.11ax HE20(Full RU)	Test Channel :	06
-------------	------------------------	----------------	----

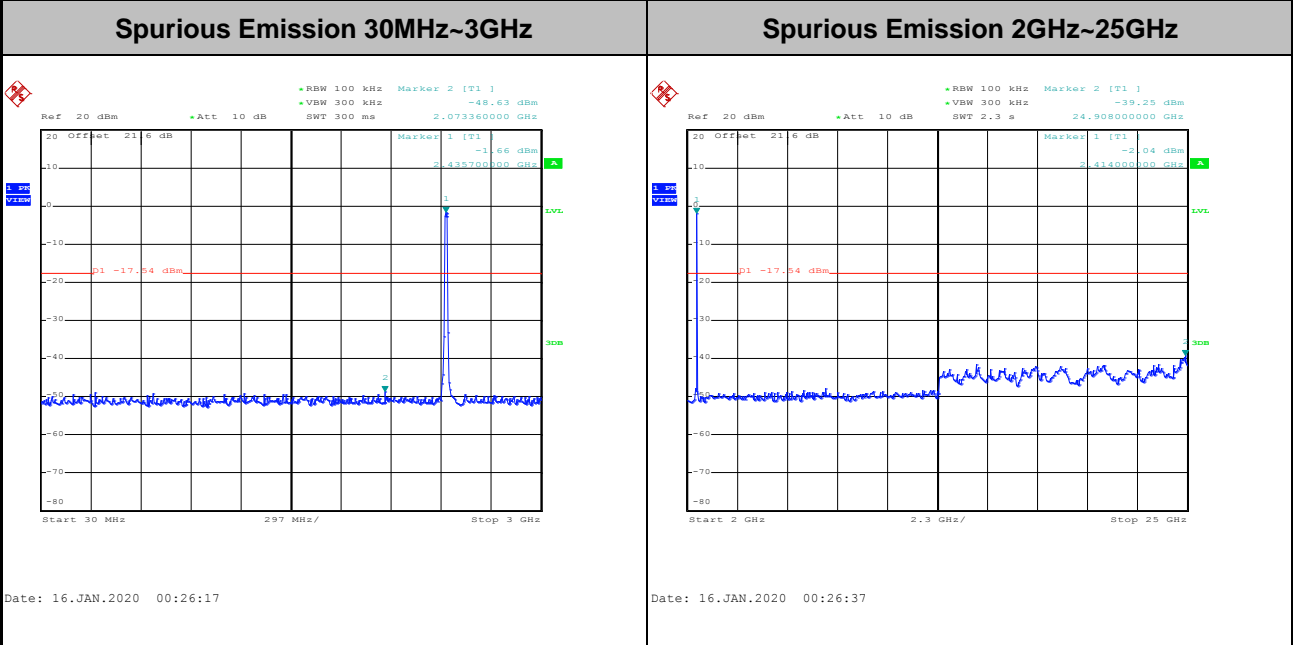
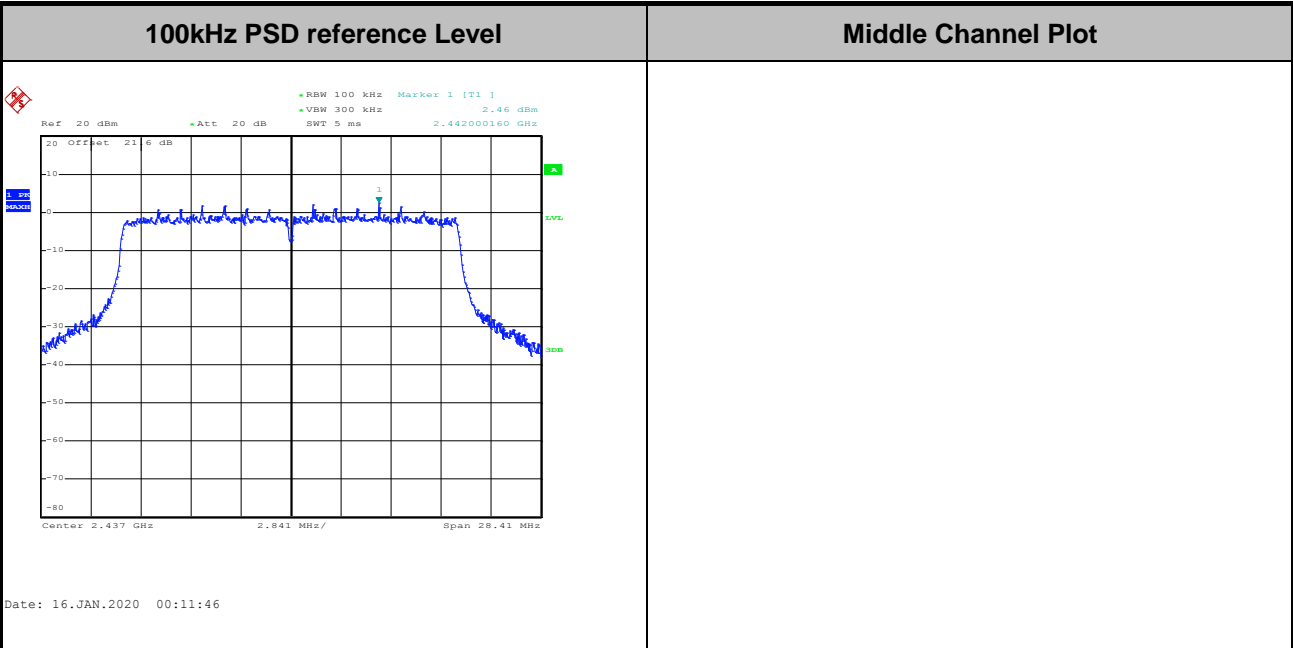



Test Mode :	802.11ax HE20(Full RU)	Test Channel :	11
--------------------	------------------------	-----------------------	----

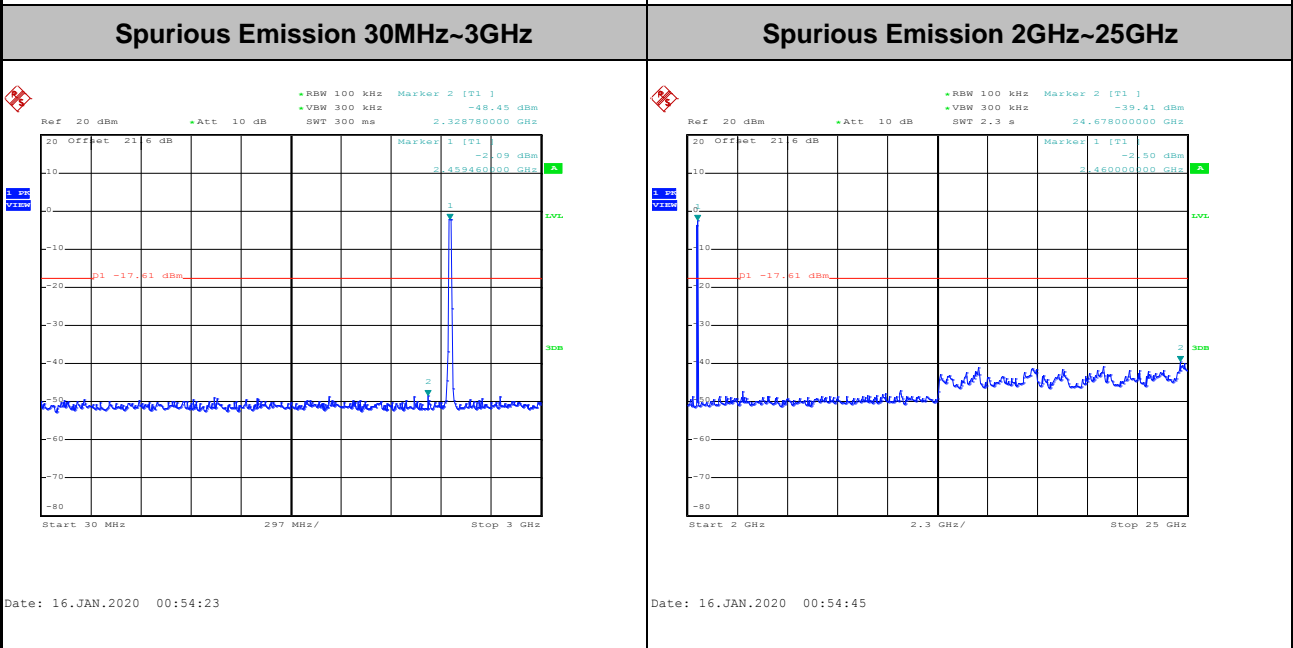
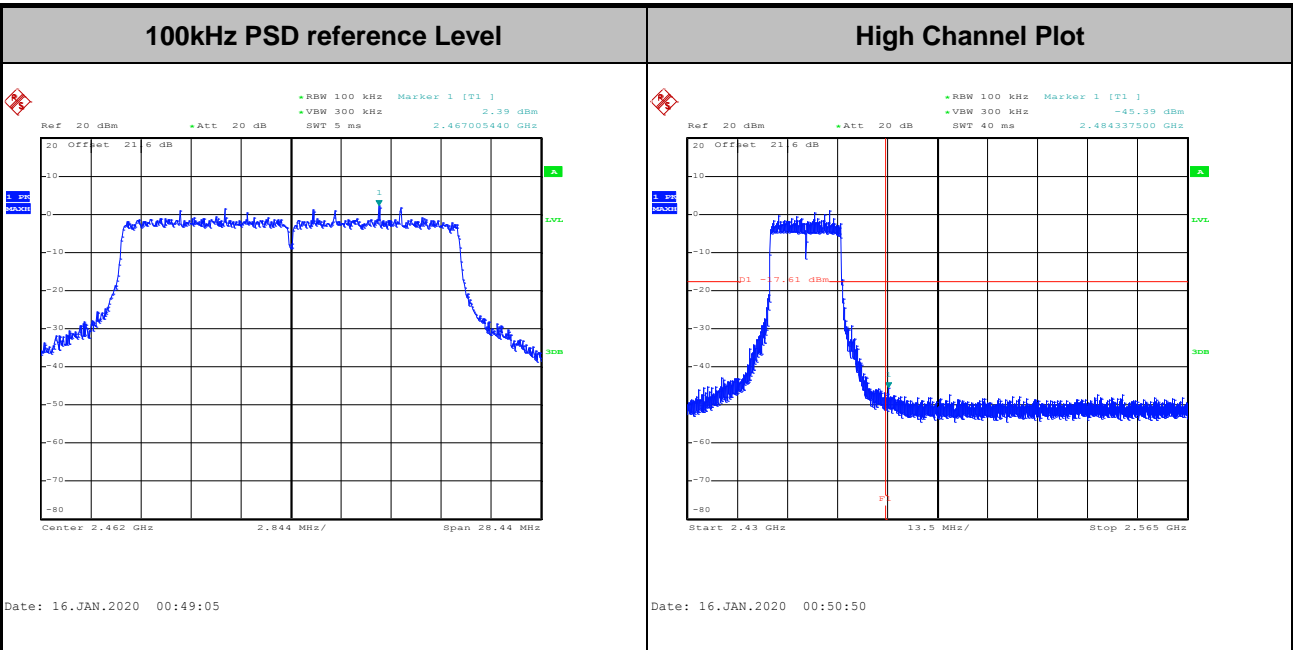



Test Mode :	802.11ax HE20(Partial RU 26/0)	Test Channel :	01
--------------------	--------------------------------	-----------------------	----

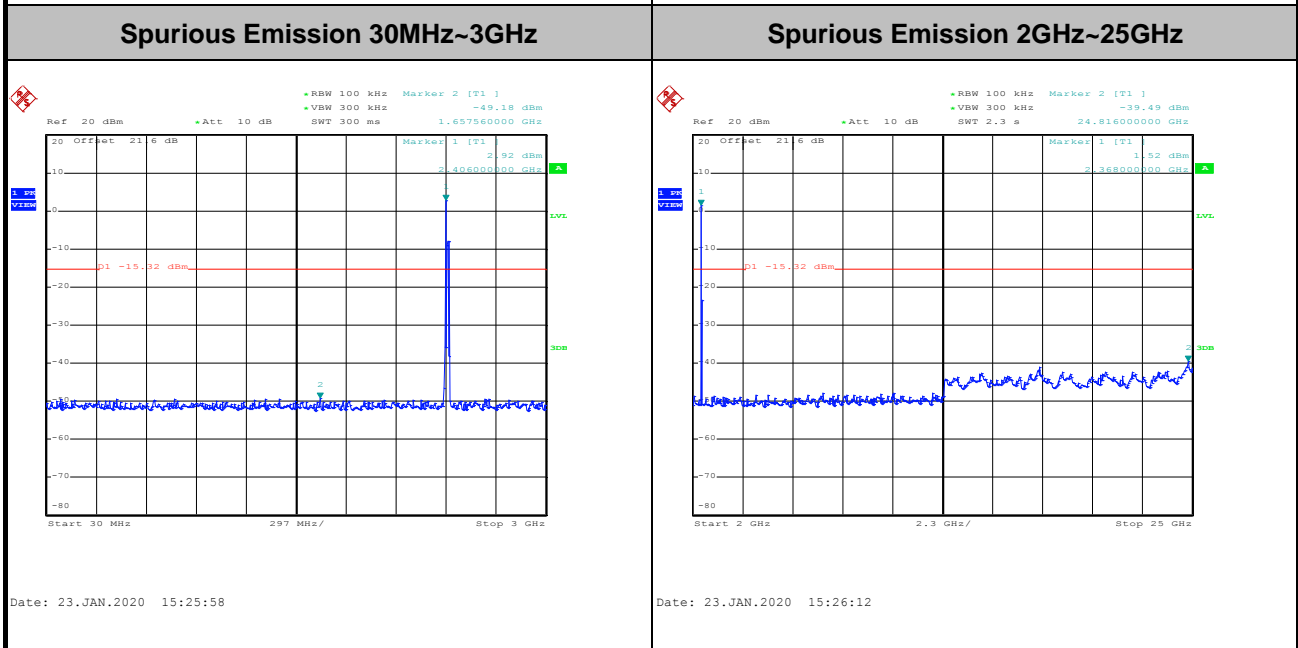
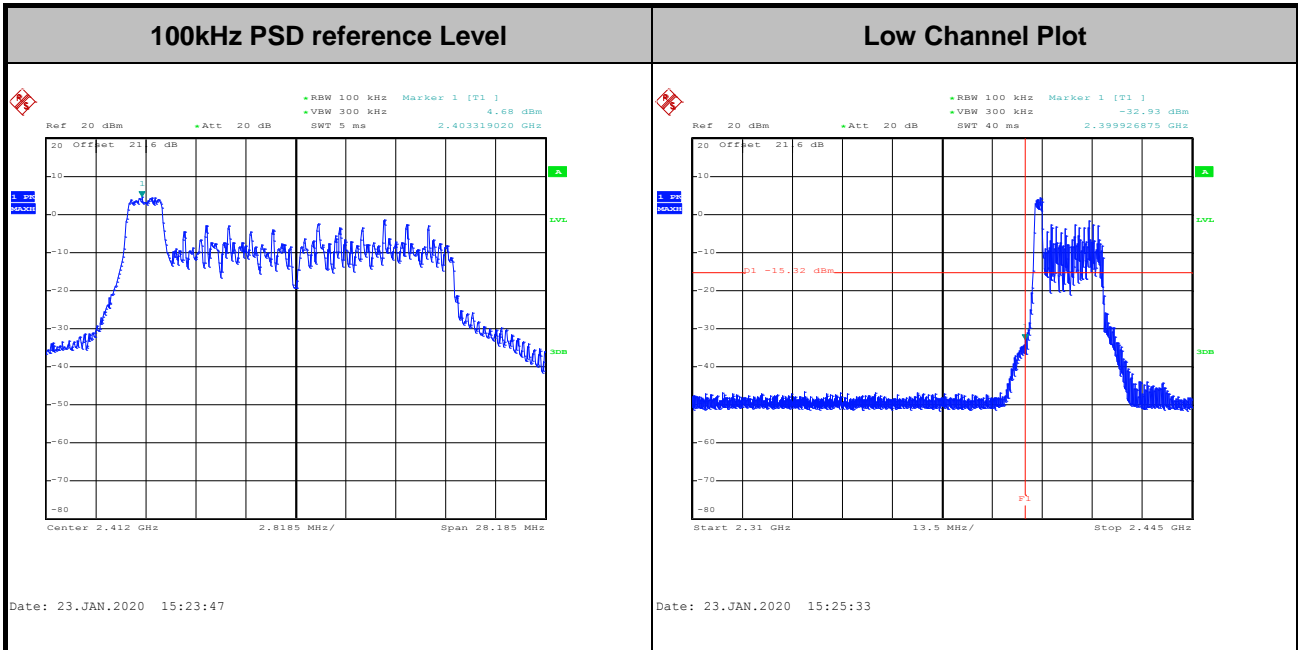



Test Mode :	802.11ax HE20(Partial RU 26/8)	Test Channel :	11
-------------	--------------------------------	----------------	----

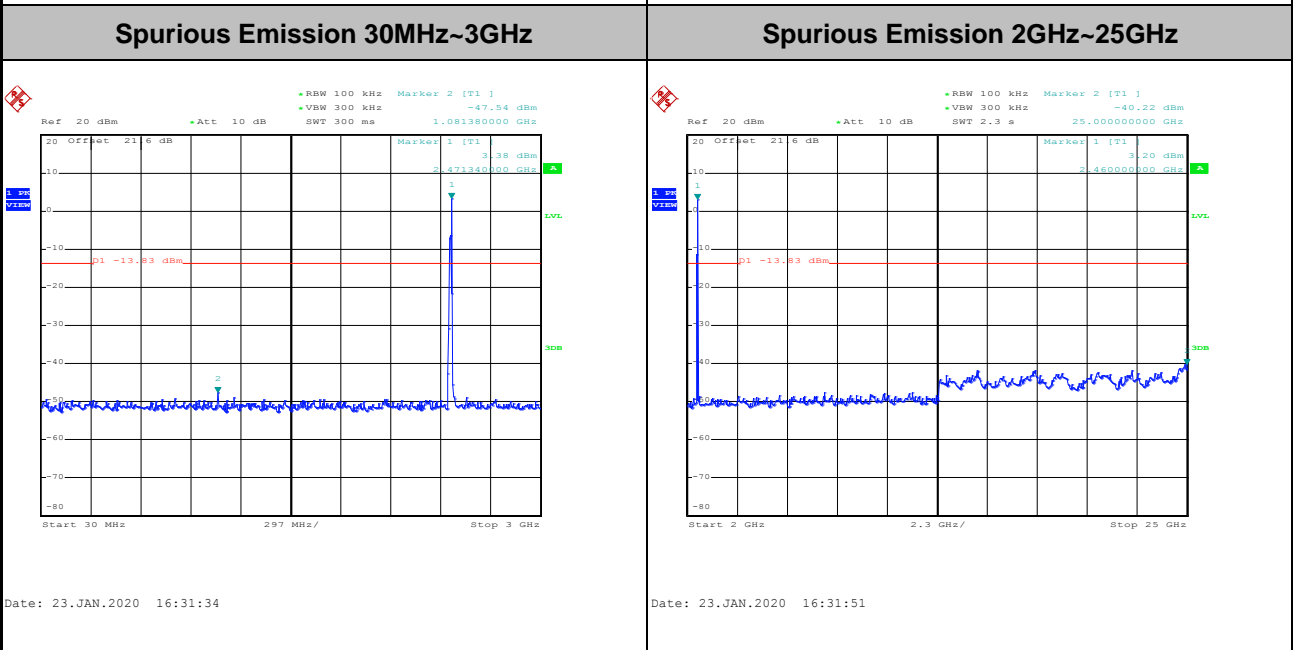
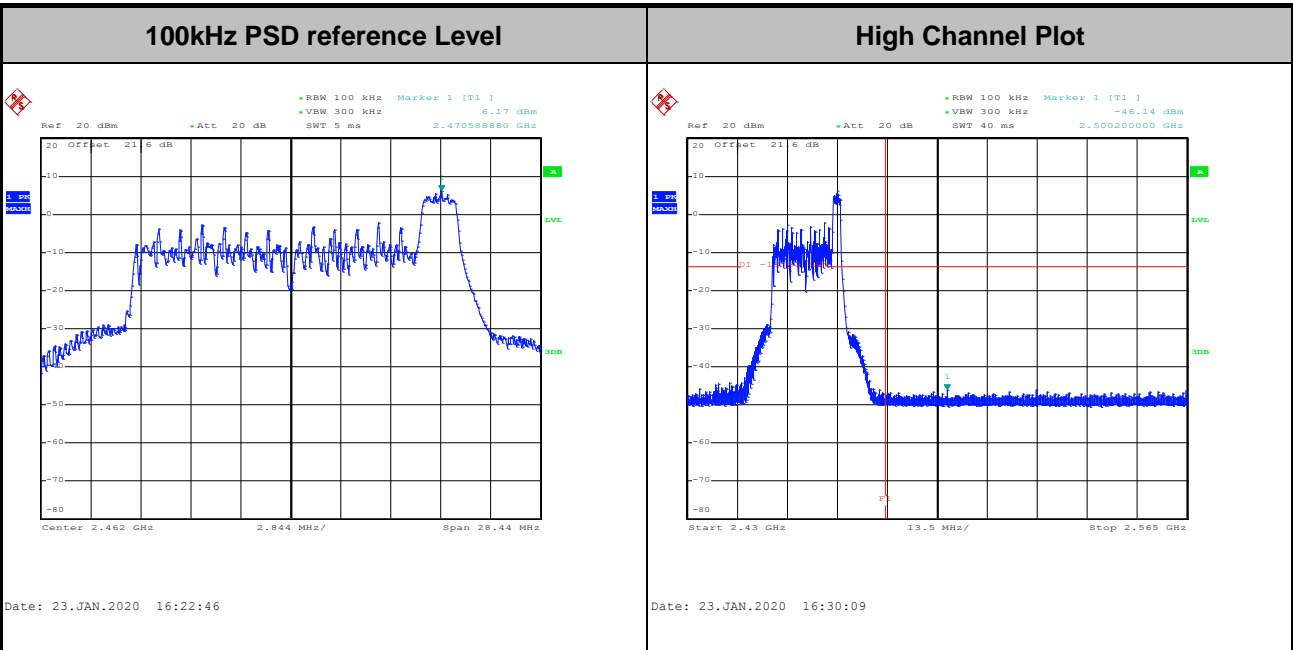



Test Mode :	802.11ax HE20(Partial RU 52/37)	Test Channel :	01
-------------	---------------------------------	----------------	----

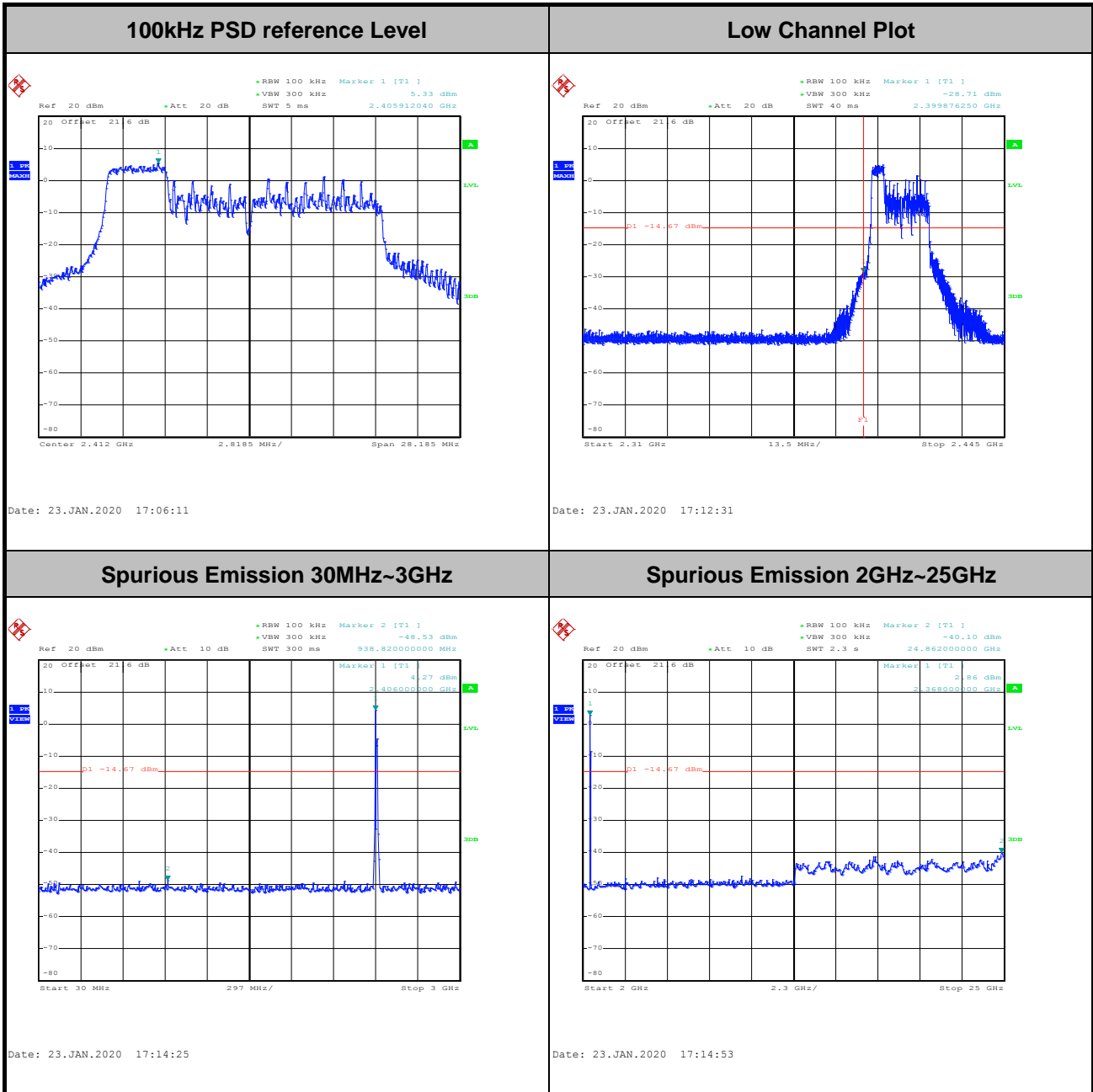



Test Mode :	802.11ax HE20(Partial RU 52/40)	Test Channel :	11
--------------------	---------------------------------	-----------------------	----

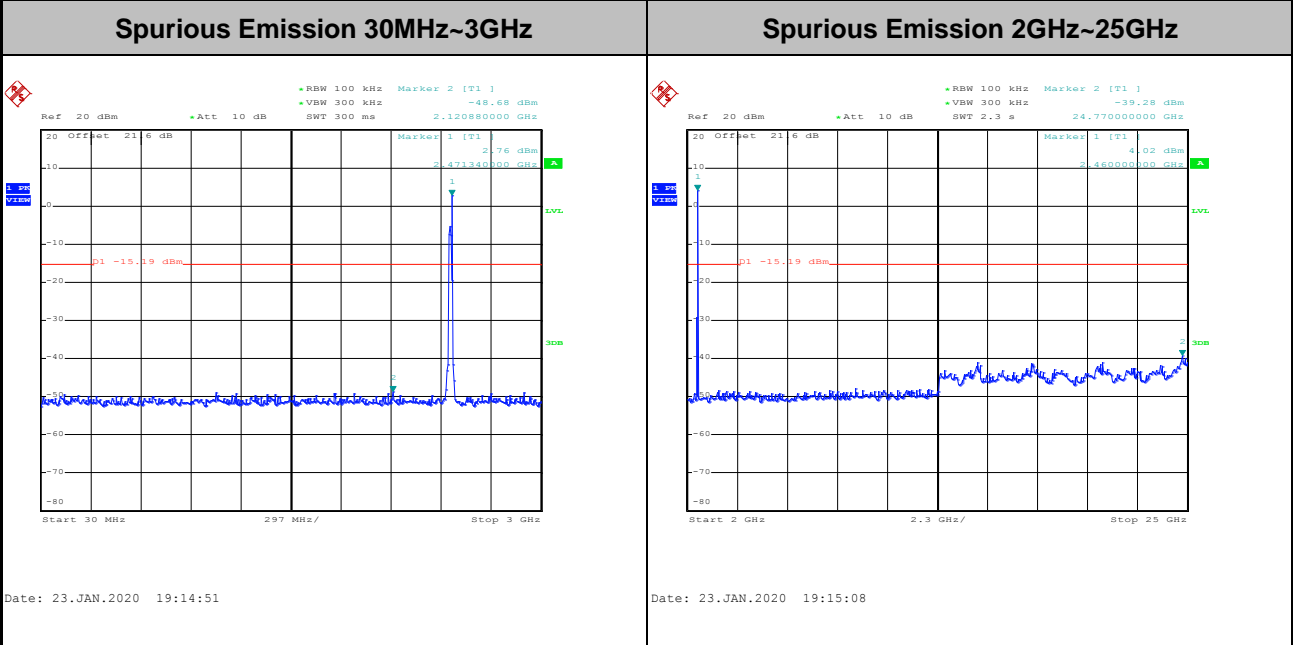
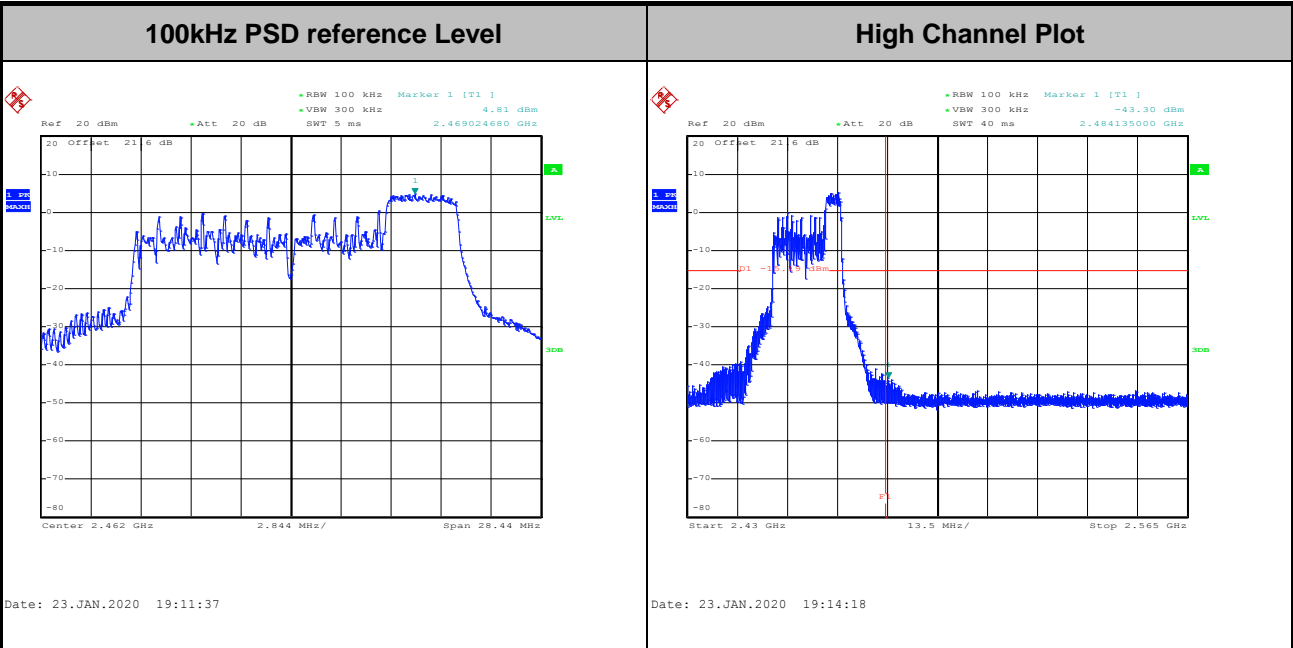



Test Mode :	802.11ax HE20(Partial RU 106/53)	Test Channel :	01
-------------	----------------------------------	----------------	----

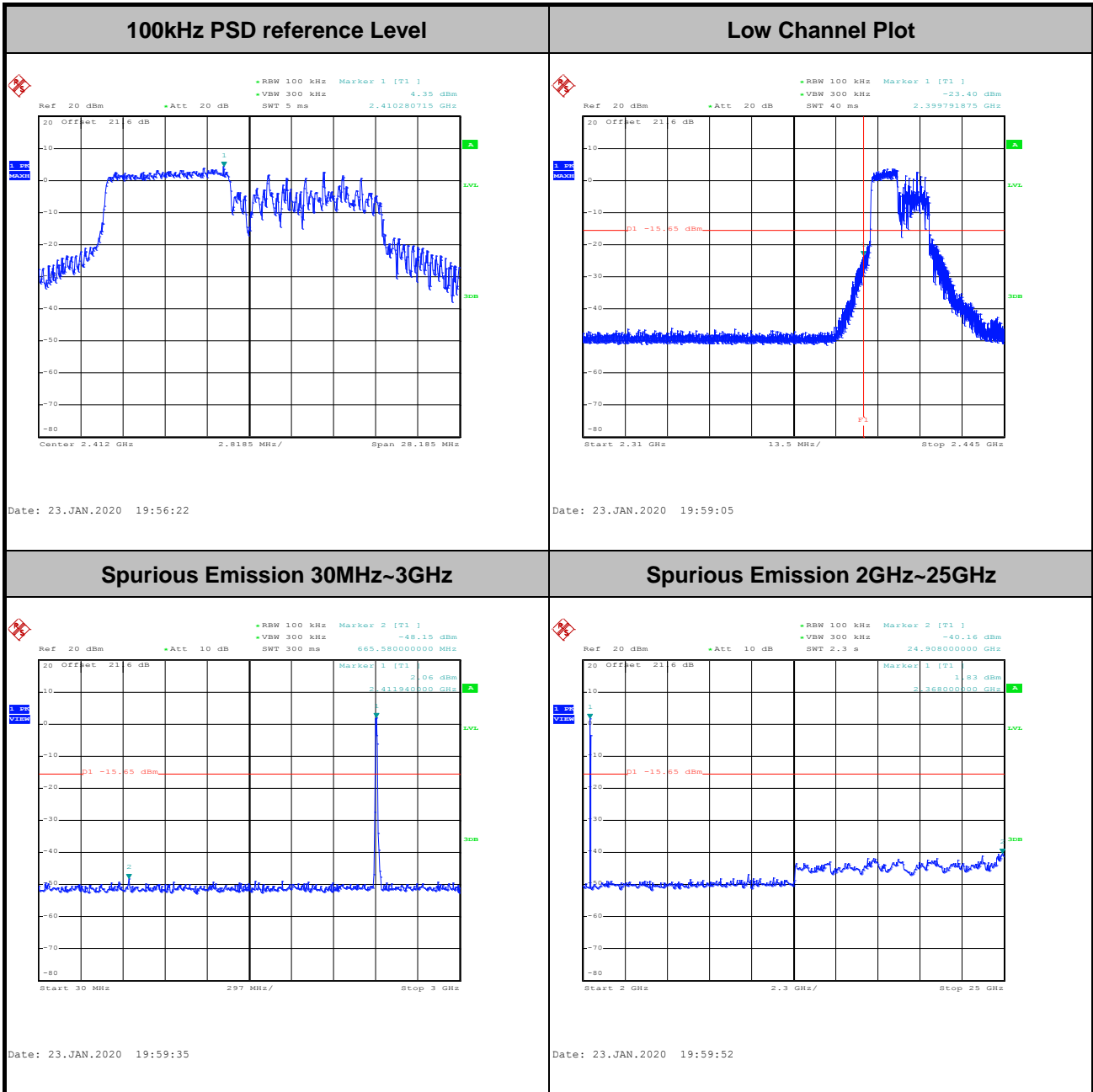



Test Mode :	802.11ax HE20(Partial RU 106/54)	Test Channel :	11
--------------------	----------------------------------	-----------------------	----

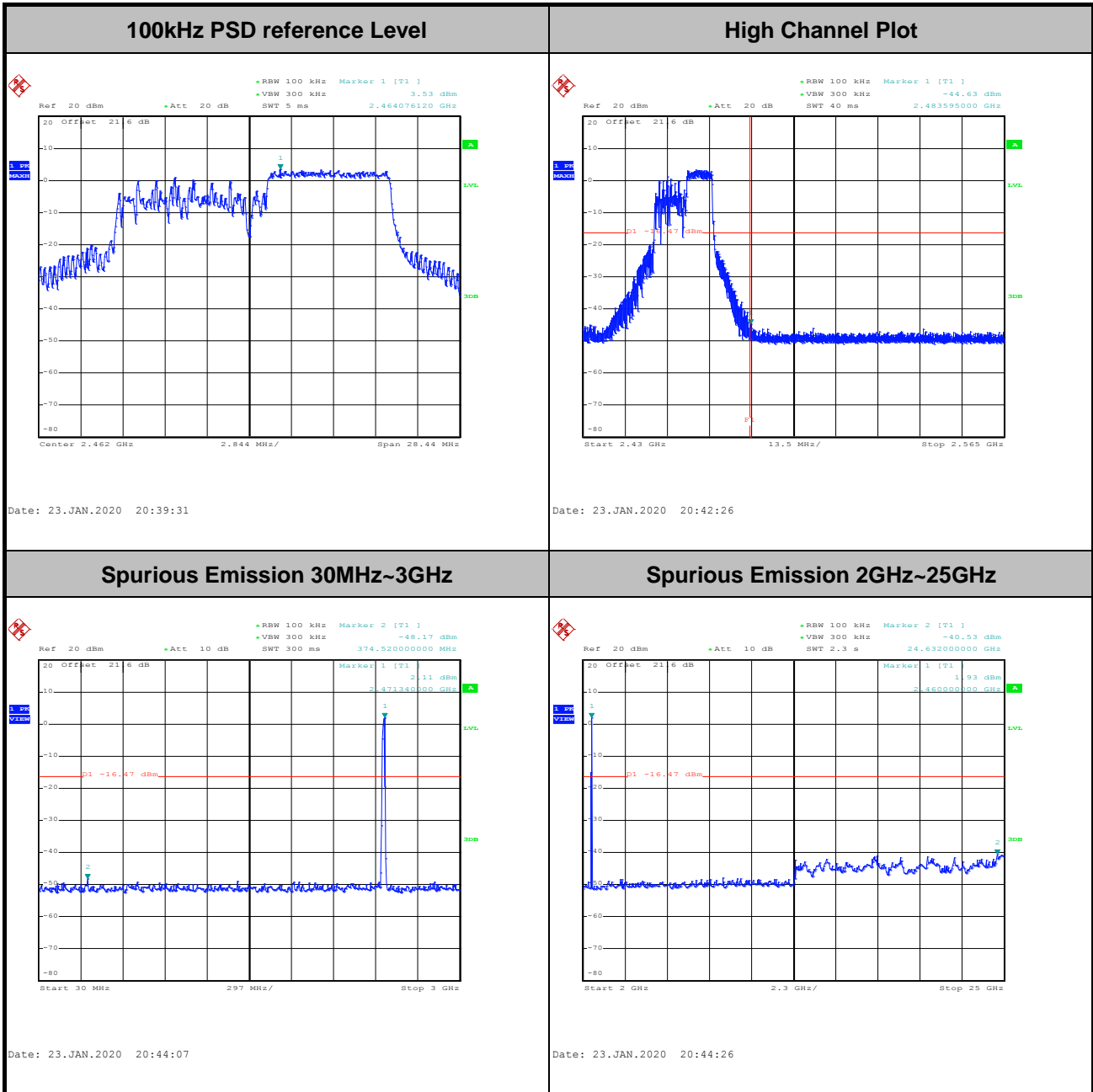



3.5 Radiated Band Edges and Spurious Emission Measurement

3.5.1 Limit of Radiated band edge and Spurious Emission Measurement

In any 100 kHz bandwidth outside the intentional radiator frequency band, all harmonics/spurious must be at least 20 dB below the highest emission level within the authorized band. If the output power of this device was measured by spectrum analyzer, the attenuation under this paragraph shall be 30 dB instead of 20 dB. In addition, radiated emissions which fall in the restricted bands must also comply with the limits as below.

Frequency (MHz)	Field Strength (microvolts/meter)	Measurement Distance (meters)
0.009 – 0.490	2400/F(kHz)	300
0.490 – 1.705	24000/F(kHz)	30
1.705 – 30.0	30	30
30 – 88	100	3
88 – 216	150	3
216 - 960	200	3
Above 960	500	3

3.5.2 Measuring Instruments

See list of measuring equipment of this test report.



3.5.3 Test Procedures

1. The testing follows the ANSI C63.10 Section 11.12.1 Radiated emission measurements.
2. The EUT was arranged to its worst case and then tune the antenna tower (from 1 m to 4 m) and turntable (from 0 degree to 360 degrees) to find the maximum reading. A pre-amp and a high pass filter are used for the test in order to get better signal level.
3. The EUT was placed on a turntable with 0.8 meter for frequency below 1GHz and 1.5 meter for frequency above 1GHz respectively above ground.
4. The EUT was set 3 meters from the interference receiving antenna, which was mounted on the top of a variable height antenna tower.
5. Corrected Reading: Antenna Factor + Cable Loss + Read Level - Preamp Factor = Level
6. For testing below 1GHz, if the emission level of the EUT in peak mode was 3 dB lower than the limit specified, then peak values of EUT will be reported, otherwise, the emissions will be repeated one by one using the CISPR quasi-peak method and reported.
7. For testing above 1GHz, the emission level of the EUT in peak mode was 20dB lower than average limit (that means the emission level in average mode also complies with the limit in average mode), then peak values of EUT will be reported, otherwise, the emissions will be measured in average mode again and reported.
8. Use the following spectrum analyzer settings:
 - (1) Span shall wide enough to fully capture the emission being measured;
 - (2) Set RBW=100 kHz for $f < 1$ GHz; VBW \geq RBW; Sweep = auto; Detector function = peak; Trace = max hold;
 - (3) Set RBW = 1 MHz, VBW= 3MHz for $f \geq 1$ GHz for peak measurement.
For average measurement:
 - VBW = 10 Hz, when duty cycle is no less than 98 percent.
 - VBW $\geq 1/T$, when duty cycle is less than 98 percent where T is the minimum transmission duration over which the transmitter is on and is transmitting at its maximum power control level for the tested mode of operation.

3.5.4 Test Setup

For radiated emissions below 30MHz

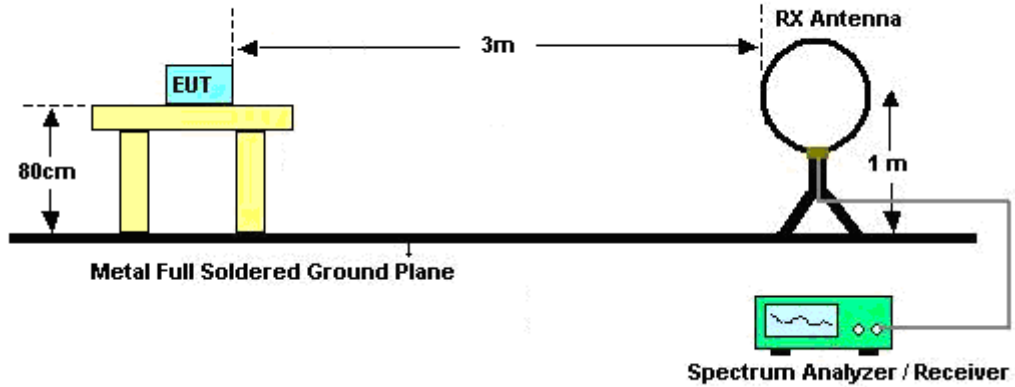

For radiated emissions from 30MHz to 1GHz

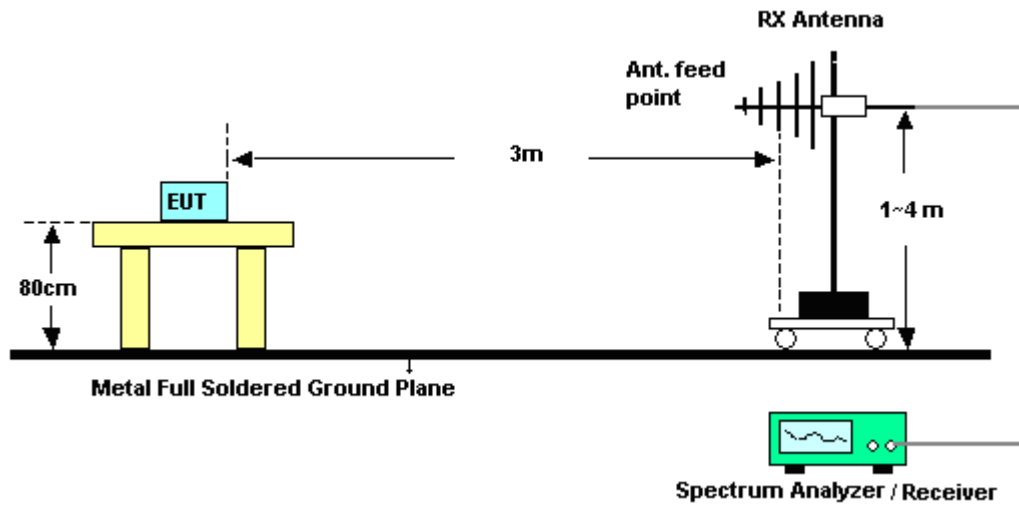

For radiated emissions from 1GHz to 18GHz

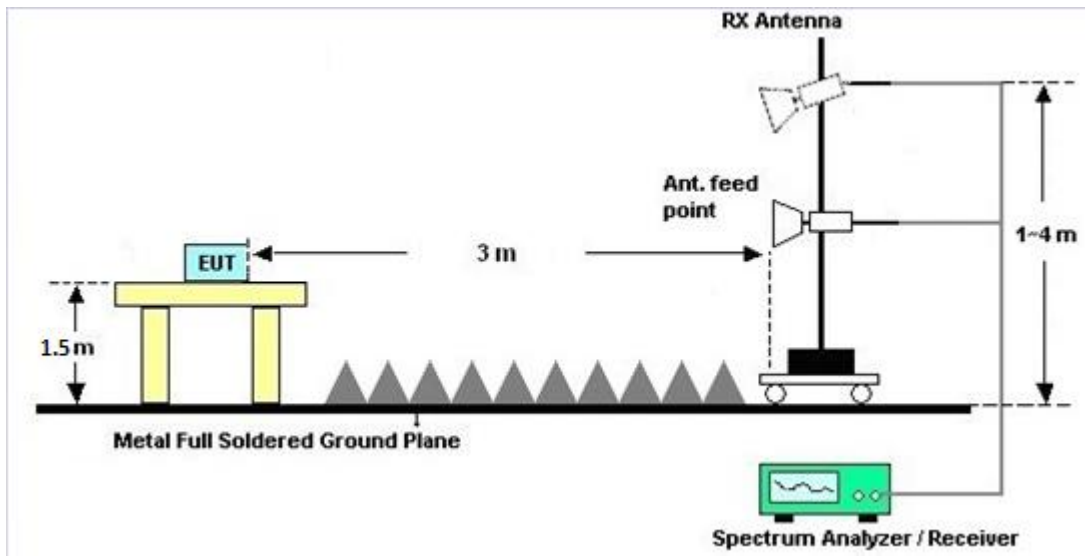

For radiated emissions from 18GHz to 26GHz

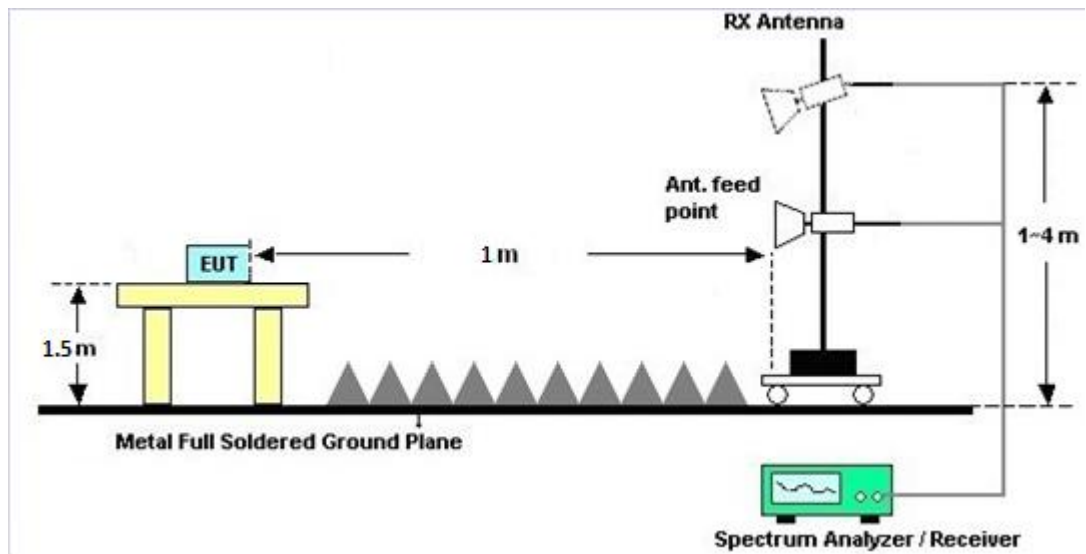



3.5.5 Test Results of Radiated Spurious Emissions (9kHz ~ 30MHz)

The low frequency, which started from 9 kHz to 30MHz, was pre-scanned and the result which was 20dB lower than the limit line was not reported.

There is a comparison data of both open-field test site and alternative test site - semi-Anechoic chamber according to 414788 D01 Radiated Test Site v01r01, and the result came out very similar.

3.5.6 Test Result of Radiated Spurious at Band Edges

Please refer to Appendix C and D.

3.5.7 Duty Cycle

Please refer to Appendix E.

3.5.8 Test Result of Radiated Spurious Emission (30MHz ~ 10th Harmonic)

Please refer to Appendix C and D.



3.6 AC Conducted Emission Measurement

3.6.1 Limit of AC Conducted Emission

For equipment that is designed to be connected to the public utility (AC) power line, the radio frequency voltage that is conducted back onto the AC power line on any frequency or frequencies within the band 150 kHz to 30 MHz shall not exceed the limits in the following table.

Frequency of Emission (MHz)	Conducted Limit (dB μ V)	
	Quasi-Peak	Average
0.15-0.5	66 to 56*	56 to 46*
0.5-5	56	46
5-30	60	50

*Decreases with the logarithm of the frequency.

3.6.2 Measuring Instruments

See list of measuring equipment of this test report.

3.6.3 Test Procedures

1. The EUT was placed 0.4 meter from the conducting wall of the shielding room, and it was kept at least 80 centimeters from any other grounded conducting surface.
2. Connect EUT to the power mains through a line impedance stabilization network (LISN).
3. All the support units are connecting to the other LISN.
4. The LISN provides 50 ohm coupling impedance for the measuring instrument.
5. The FCC states that a 50 ohm, 50 microhenry LISN should be used.
6. Both sides of AC line were checked for maximum conducted interference.
7. The frequency range from 150 kHz to 30 MHz was searched.
8. Set the test-receiver system to Peak Detect Function and specified bandwidth (IF bandwidth = 9kHz) with Maximum Hold Mode.

3.6.4 Test Setup

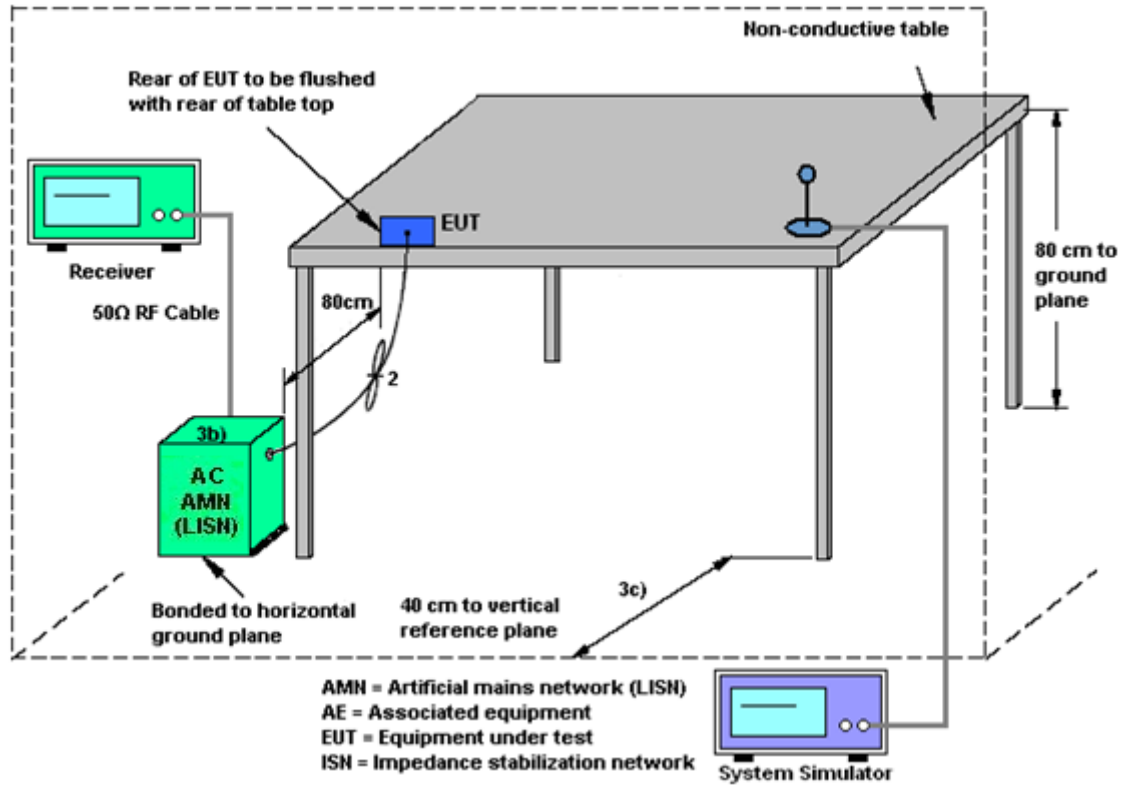

3.6.5 Test Result of AC Conducted Emission

Please refer to Appendix B.



3.7 Antenna Requirements

3.7.1 Standard Applicable

If directional gain of transmitting Antennas is greater than 6dBi, the power shall be reduced by the same level in dB comparing to gain minus 6dBi. The use of a permanently attached Antenna or of an Antenna that uses a unique coupling to the intentional radiator shall be considered sufficient to comply with the rule.

3.7.2 Antenna Anti-Replacement Construction

An embedded-in antenna design is used.

3.7.3 Antenna Gain

<CDD Modes >

FCC KDB 662911 D01 Multiple Transmitter Output v02r01

For CDD transmissions, directional gain is calculated as

Directional gain = G_{ANT} + Array Gain, where Array Gain is as follows.

For power spectral density (PSD) measurements on all devices,

Array Gain = $10 \log(N_{ANT}/N_{SS}=1)$ dB.

For power measurements on IEEE 802.11 devices,

Array Gain = 0 dB (i.e., no array gain) for $N_{ANT} \leq 4$.

Directional gain may be calculated by using the formulas applicable to equal gain antennas with G_{ANT} set equal to the gain of the antenna having the highest gain;

The EUT supports CDD mode.

For power, the directional gain G_{ANT} is set equal to the antenna having the highest gain, i.e., F)2)f)i).

For PSD, the directional gain calculation is following F)2)f)ii) of KDB 662911 D01 v02r01.

The power and PSD limit should be modified if the directional gain of EUT is over 6 dBi,

The directional gain "DG" is calculated as following table.

<CDD Modes>						
			DG	DG	Power	PSD
			for	for	Limit	Limit
	Ant. 1	Ant. 2	Power	PSD	Reduction	Reduction
	(dBi)	(dBi)	(dBi)	(dBi)	(dB)	(dB)
2.4 GHz	-2.40	-11.40	-2.40	-2.77	0.00	0.00

$Power\ Limit\ Reduction = DG(Power) - 6dBi, (min = 0)$

$PSD\ Limit\ Reduction = DG(PSD) - 6dBi, (min = 0)$



4 List of Measuring Equipment

Instrument	Manufacturer	Model No.	Serial No.	Characteristics	Calibration Date	Test Date	Due Date	Remark
Loop Antenna	Rohde & Schwarz	HFH2-Z2	100488	9 kHz~30 MHz	Dec. 26, 2019	Jan. 04, 2020~ Jan. 31, 2020	Dec. 25, 2020	Radiation (03CH16-HY)
Bilog Antenna	TESEQ	CBL6111D& 00802N1D0 1N-06	47020&06	30MHz to 1GHz	Oct. 13, 2019	Jan. 04, 2020~ Jan. 31, 2020	Oct. 12, 2020	Radiation (03CH16-HY)
Horn Antenna	SCHWARZBE CK	BBHA 9120 D	9120D-1522	1G~18GHz	Sep. 19, 2019	Jan. 04, 2020~ Jan. 31, 2020	Sep. 18, 2020	Radiation (03CH16-HY)
Amplifier	SONOMA	310N	371607	9kHz~1000MHz	Oct. 01, 2019	Jan. 04, 2020~ Jan. 31, 2020	Sep. 30, 2020	Radiation (03CH16-HY)
Preamplifier	Jet-Power	JPA0118-55- 303	1710001800 054001	1GHz~18GHz	May 19, 2019	Jan. 04, 2020~ Jan. 31, 2020	May 18, 2020	Radiation (03CH16-HY)
Preamplifier	EMEC	EMC184045 B	980192	18GHz ~40GHz	Jul. 10, 2019	Jan. 04, 2020~ Jan. 31, 2020	Jul. 09, 2020	Radiation (03CH16-HY)
Preamplifier	Keysight	83017A	MY5327026 4	1GHz~26.5GHz	Dec. 11, 2019	Jan. 04, 2020~ Jan. 31, 2020	Dec. 10, 2020	Radiation (03CH16-HY)
EMI Test Receiver	Keysight	N9038A (MXE)	MY5542017 0	20MHz~8.4GHz	Mar. 08, 2019	Jan. 04, 2020~ Jan. 31, 2020	Mar. 07, 2020	Radiation (03CH16-HY)
Spectrum Analyzer	Agilent	E4446A	MY5018013 6	3Hz~44GHz	Apr. 29, 2019	Jan. 04, 2020~ Jan. 31, 2020	Apr. 28, 2020	Radiation (03CH16-HY)
RF Cable	HUBER + SUHNER	SUCOFLEX 104	MY11680/4P E	NA	Aug. 30, 2019	Jan. 04, 2020~ Jan. 31, 2020	Aug. 29, 2020	Radiation (03CH16-HY)
RF Cable	HUBER + SUHNER	SUCOFLEX 104	MY11688/4P E	NA	Aug. 30, 2019	Jan. 04, 2020~ Jan. 31, 2020	Aug. 29, 2020	Radiation (03CH16-HY)
RF Cable	HUBER + SUHNER	SUCOFLEX 102	EC-A5-300-5 757	NA	Aug. 30, 2019	Jan. 04, 2020~ Jan. 31, 2020	Aug. 29, 2020	Radiation (03CH16-HY)
RF Cable	HUBER + SUHNER	SUCOFLEX 102	505134/2	30MHz~40GHz	Feb. 26, 2019	Jan. 04, 2020~ Jan. 31, 2020	Feb. 25, 2020	Radiation (03CH16-HY)
RF Cable	HUBER + SUHNER	SUCOFLEX 102	800740/2	30MHz~40GHz	Feb. 26, 2019	Jan. 04, 2020~ Jan. 31, 2020	Feb. 25, 2020	Radiation (03CH16-HY)
SHF-EHF Horn Antenna	SCHWARZBE CK	BBHA 9170	BBHA91705 76	18GHz~40GHz	May 14, 2019	Jan. 04, 2020~ Jan. 31, 2020	May 13, 2020	Radiation (03CH16-HY)
Preamplifier	EMEC	EM18G40G	060715	18GHz~40GHz	Dec. 13, 2019	Jan. 04, 2020~ Jan. 31, 2020	Dec. 12, 2020	Radiation (03CH16-HY)
Hygrometer	TECPEL	DTM-303B	TP161243	N/A	Jun. 17, 2019	Jan. 04, 2020~ Jan. 31, 2020	Jun. 16, 2020	Radiation (03CH16-HY)
Software	Audix	E3 6.2009-8-24	RK-001136	N/A	N/A	Jan. 04, 2020~ Jan. 31, 2020	N/A	Radiation (03CH16-HY)
Filter	Wainwright	WLK4-1000- 1530-8000-4 0SS	SN11	1.53G Low Pass	Sep. 15, 2019	Jan. 04, 2020~ Jan. 31, 2020	Sep. 14, 2020	Radiation (03CH16-HY)
Filter	Wainwright	WHKX12-27 00-3000-180 00-60SS	SN3	3GHz High Pass Filter	Sep. 15, 2019	Jan. 04, 2020~ Jan. 31, 2020	Sep. 14, 2020	Radiation (03CH16-HY)



Instrument	Manufacturer	Model No.	Serial No.	Characteristics	Calibration Date	Test Date	Due Date	Remark
AC Power Source	ChainTek	APC-1000W	N/A	N/A	N/A	Dec. 26, 2019~ Jan. 16, 2020	N/A	Conduction (CO05-HY)
EMI Test Receiver	Rohde & Schwarz	ESR3	102388	9kHz~3.6GHz	Nov. 15, 2019	Dec. 26, 2019~ Jan. 16, 2020	Nov. 14, 2020	Conduction (CO05-HY)
Hygrometer	Testo	608-H1	34913912	N/A	Mar. 19, 2019	Dec. 26, 2019~ Jan. 16, 2020	Mar. 18, 2020	Conduction (CO05-HY)
LISN	Rohde & Schwarz	ENV216	100081	9kHz~30MHz	Nov. 15, 2019	Dec. 26, 2019~ Jan. 16, 2020	Nov. 14, 2020	Conduction (CO05-HY)
Software	Rohde & Schwarz	EMC32 V10.30	N/A	N/A	N/A	Dec. 26, 2019~ Jan. 16, 2020	N/A	Conduction (CO05-HY)
LF Cable	HUBER + SUHNER	RG-214/U	LF01	N/A	Dec. 31, 2018	Dec. 26, 2019	Dec. 30, 2019	Conduction (CO05-HY)
LF Cable	HUBER + SUHNER	RG-214/U	LF01	N/A	Jan. 02, 2020	Jan. 16, 2020	Jan. 01, 2021	Conduction (CO05-HY)
Pulse Limiter	Rohde & Schwarz	ESH3-Z2	100851	N/A	Dec. 31, 2018	Dec. 26, 2019	Dec. 30, 2019	Conduction (CO05-HY)
Pulse Limiter	Rohde & Schwarz	ESH3-Z2	100851	N/A	Jan. 02, 2020	Jan. 16, 2020	Jan. 01, 2021	Conduction (CO05-HY)
Hygrometer	Testo	608-H2	41410069	N/A	Jun. 17, 2019	Dec. 19, 2019~ Feb. 20, 2020	Jun. 16, 2020	Conducted (TH05-HY)
Power Sensor	DARE	RPR3006W	13100030SN O32	9kHz~6GHz	Dec. 17, 2019	Dec. 19, 2019~ Feb. 20, 2020	Dec. 16, 2020	Conducted (TH05-HY)
Signal Analyzer	Rohde & Schwarz	FSV40	101566	10Hz~40GHz	Jul. 15, 2019	Dec. 19, 2019~ Feb. 20, 2020	Jul. 14, 2020	Conducted (TH05-HY)
Spectrum Analyzer	Rohde & Schwarz	FSP40	100055	9kHz-40GHz	Aug. 14, 2019	Dec. 19, 2019~ Feb. 20, 2020	Aug. 13, 2020	Conducted (TH05-HY)
Switch Control Manframe	E-IUSTRUMENT	ETF-1405-0	EC1900067	N/A	Aug. 15, 2019	Dec. 19, 2019~ Feb. 20, 2020	Aug. 14, 2020	Conducted (TH05-HY)



5 Uncertainty of Evaluation

Uncertainty of Conducted Emission Measurement (150kHz ~ 30MHz)

Measuring Uncertainty for a Level of Confidence of 95% ($U = 2Uc(y)$)	2.0
---	-----

Uncertainty of Radiated Emission Measurement (30 MHz ~ 1000 MHz)

Measuring Uncertainty for a Level of Confidence of 95% ($U = 2Uc(y)$)	4.9
---	-----

Uncertainty of Radiated Emission Measurement (1000 MHz ~ 18000 MHz)

Measuring Uncertainty for a Level of Confidence of 95% ($U = 2Uc(y)$)	6.7
---	-----

Uncertainty of Radiated Emission Measurement (18000 MHz ~ 40000 MHz)

Measuring Uncertainty for a Level of Confidence of 95% ($U = 2Uc(y)$)	3.9
---	-----

Appendix A. Test Result of Conducted Test Items

Test Engineer:	Derek Hsu and Shiming Liu	Temperature:	21~25	°C
Test Date:	2019/12/19~2020/1/23	Relative Humidity:	51~54	%

TEST RESULTS DATA
Peak Power Spectral Density

2.4GHz Band MIMO												
Mod.	Data Rate	NTX	CH.	Freq. (MHz)	Peak PSD (dBm/3kHz)			DG (dBi)		Peak PSD Limit (dBm/3kHz)		Pass/Fail
					Ant1	Ant2	Worse + 3.01	Ant1	Ant2	Ant1	Ant2	
11b	1Mbps	2	1	2412	-10.57	-14.07	-7.56	-2.77		8.00		Pass
11b	1Mbps	2	6	2437	-10.10	-13.98	-7.09	-2.77		8.00		Pass
11b	1Mbps	2	11	2462	-9.93	-14.16	-6.92	-2.77		8.00		Pass
11g	6Mbps	2	1	2412	-15.66	-15.27	-12.26	-2.77		8.00		Pass
11g	6Mbps	2	6	2437	-13.31	-14.61	-10.30	-2.77		8.00		Pass
11g	6Mbps	2	11	2462	-14.48	-14.96	-11.47	-2.77		8.00		Pass
HT20	MCS0	2	1	2412	-14.17	-13.71	-10.70	-2.77		8.00		Pass
HT20	MCS0	2	6	2437	-12.45	-12.95	-9.44	-2.77		8.00		Pass
HT20	MCS0	2	11	2462	-13.39	-13.05	-10.04	-2.77		8.00		Pass

Measured power density (dBm) has offset with cable loss.

TEST RESULTS DATA
Peak Output Power

2.4GHz Band Single Antenna																
Mod.	Data Rate	NTX	CH.	Freq. (MHz)	Peak Conducted Power (dBm)			Conducted Power Limit (dBm)		DG (dBi)		EIRP Power (dBm)		EIRP Power Limit (dBm)		Pass /Fail
					Ant1	Ant2	SUM	Ant1	Ant2	Ant1	Ant2	Ant1	Ant2	Ant1	Ant2	
11b	1Mbps	1	1	2412	16.90	13.28		30.00	30.00	-2.40	-11.40	14.50	1.88	36.00	36.00	Pass
11b	1Mbps	1	6	2437	16.85	13.25		30.00	30.00	-2.40	-11.40	14.45	1.85	36.00	36.00	Pass
11b	1Mbps	1	11	2462	17.00	13.45		30.00	30.00	-2.40	-11.40	14.60	2.05	36.00	36.00	Pass
11g	6Mbps	1	1	2412	20.10	19.61		30.00	30.00	-2.40	-11.40	17.70	8.21	36.00	36.00	Pass
11g	6Mbps	1	6	2437	20.70	20.86		30.00	30.00	-2.40	-11.40	18.30	9.46	36.00	36.00	Pass
11g	6Mbps	1	11	2462	20.40	20.93		30.00	30.00	-2.40	-11.40	18.00	9.53	36.00	36.00	Pass
HT20	MCS0	1	1	2412	20.30	19.67		30.00	30.00	-2.40	-11.40	17.90	8.27	36.00	36.00	Pass
HT20	MCS0	1	6	2437	20.82	21.12		30.00	30.00	-2.40	-11.40	18.42	9.72	36.00	36.00	Pass
HT20	MCS0	1	11	2462	20.50	21.23		30.00	30.00	-2.40	-11.40	18.10	9.83	36.00	36.00	Pass

2.4GHz Band MIMO																
Mod.	Data Rate	NTX	CH.	Freq. (MHz)	Peak Conducted Power (dBm)			Conducted Power Limit (dBm)		DG (dBi)		EIRP Power (dBm)		EIRP Power Limit (dBm)		Pass /Fail
					Ant1	Ant2	SUM	Ant1	Ant2	Ant1	Ant2	Ant1	Ant2	Ant1	Ant2	
11b	1Mbps	2	1	2412	16.91	13.30	18.48	30.00		-2.40		16.08		36.00		Pass
11b	1Mbps	2	6	2437	16.88	13.28	18.45	30.00		-2.40		16.05		36.00		Pass
11b	1Mbps	2	11	2462	17.02	13.47	18.61	30.00		-2.40		16.21		36.00		Pass
11g	6Mbps	2	1	2412	20.12	19.70	22.93	30.00		-2.40		20.53		36.00		Pass
11g	6Mbps	2	6	2437	20.75	20.90	23.84	30.00		-2.40		21.44		36.00		Pass
11g	6Mbps	2	11	2462	20.43	20.98	23.72	30.00		-2.40		21.32		36.00		Pass
HT20	MCS0	2	1	2412	20.32	19.73	23.05	30.00		-2.40		20.65		36.00		Pass
HT20	MCS0	2	6	2437	20.85	21.15	24.01	30.00		-2.40		21.61		36.00		Pass
HT20	MCS0	2	11	2462	20.53	21.25	23.92	30.00		-2.40		21.52		36.00		Pass

Note: Measured power (dBm) has offset with cable loss.

TEST RESULTS DATA
Average Output Power (Reporting Only)

2.4GHz Band Single Antenna																
Mod.	Data Rate	NTX	CH.	Freq. (MHz)	Average Conducted Power (dBm)			Conducted Power Limit (dBm)		DG (dBi)		EIRP Power (dBm)		EIRP Power Limit (dBm)		Pass /Fail
					Ant1	Ant2	SUM	Ant1	Ant2	Ant1	Ant2	Ant1	Ant2	Ant1	Ant2	
11b	1Mbps	1	1	2412	14.60	10.80		30.00	30.00	-2.40	-11.40	12.20	-0.60	36.00	36.00	Pass
11b	1Mbps	1	6	2437	14.50	10.80		30.00	30.00	-2.40	-11.40	12.10	-0.60	36.00	36.00	Pass
11b	1Mbps	1	11	2462	14.70	10.90		30.00	30.00	-2.40	-11.40	12.30	-0.50	36.00	36.00	Pass
11g	6Mbps	1	1	2412	12.70	12.70		30.00	30.00	-2.40	-11.40	10.30	1.30	36.00	36.00	Pass
11g	6Mbps	1	6	2437	14.70	13.70		30.00	30.00	-2.40	-11.40	12.30	2.30	36.00	36.00	Pass
11g	6Mbps	1	11	2462	13.80	13.80		30.00	30.00	-2.40	-11.40	11.40	2.40	36.00	36.00	Pass
HT20	MCS0	1	1	2412	12.80	12.70		30.00	30.00	-2.40	-11.40	10.40	1.30	36.00	36.00	Pass
HT20	MCS0	1	6	2437	14.70	13.60		30.00	30.00	-2.40	-11.40	12.30	2.20	36.00	36.00	Pass
HT20	MCS0	1	11	2462	13.80	13.70		30.00	30.00	-2.40	-11.40	11.40	2.30	36.00	36.00	Pass

2.4GHz Band MIMO																
Mod.	Data Rate	NTX	CH.	Freq. (MHz)	Average Conducted Power (dBm)			Conducted Power Limit (dBm)		DG (dBi)		EIRP Power (dBm)		EIRP Power Limit (dBm)		Pass /Fail
					Ant1	Ant2	SUM	Ant1	Ant2	Ant1	Ant2	Ant1	Ant2	Ant1	Ant2	
11b	1Mbps	2	1	2412	14.70	10.80	16.18	30.00		-2.40		13.78		36.00		Pass
11b	1Mbps	2	6	2437	14.60	10.80	16.11	30.00		-2.40		13.71		36.00		Pass
11b	1Mbps	2	11	2462	14.80	10.90	16.28	30.00		-2.40		13.88		36.00		Pass
11g	6Mbps	2	1	2412	12.80	12.80	15.81	30.00		-2.40		13.41		36.00		Pass
11g	6Mbps	2	6	2437	14.70	13.80	17.28	30.00		-2.40		14.88		36.00		Pass
11g	6Mbps	2	11	2462	13.80	13.81	16.82	30.00		-2.40		14.42		36.00		Pass
HT20	MCS0	2	1	2412	12.80	12.80	15.81	30.00		-2.40		13.41		36.00		Pass
HT20	MCS0	2	6	2437	14.70	13.80	17.28	30.00		-2.40		14.88		36.00		Pass
HT20	MCS0	2	11	2462	13.80	13.80	16.81	30.00		-2.40		14.41		36.00		Pass

Note: Measured power (dBm) has offset with cable loss.

TEST RESULTS DATA
6dB and 99% Occupied Bandwidth

2.4GHz Band MIMO										
Mod.	Data Rate	NTX	CH.	Freq. (MHz)	99% Occupied BW (MHz)		6dB BW (MHz)		6dB BW Limit (MHz)	Pass/Fail
					Ant1	Ant2	Ant1	Ant2		
11b	1Mbps	2	1	2412	12.80	12.90	8.04	7.56	0.50	Pass
11b	1Mbps	2	6	2437	13.00	12.90	8.04	8.06	0.50	Pass
11b	1Mbps	2	11	2462	12.95	13.00	8.06	8.05	0.50	Pass
11g	6Mbps	2	1	2412	16.85	16.65	16.37	16.32	0.50	Pass
11g	6Mbps	2	6	2437	16.85	16.65	16.32	16.32	0.50	Pass
11g	6Mbps	2	11	2462	16.85	16.70	16.33	16.32	0.50	Pass
HT20	MCS0	2	1	2412	17.90	17.85	17.56	17.59	0.50	Pass
HT20	MCS0	2	6	2437	17.90	17.80	17.60	17.56	0.50	Pass
HT20	MCS0	2	11	2462	17.90	17.85	17.58	17.63	0.50	Pass

TEST RESULTS DATA
Peak Power Spectral Density

2.4GHz Band MIMO													
Mod.	Data Rate	N _{Tx}	CH.	Freq. (MHz)	RU Config	Peak PSD (dBm/3kHz)			DG (dBi)		Peak PSD Limit (dBm/3kHz)		Pass/Fail
						Ant1	Ant2	Worse + 3.01	Ant1	Ant2	Ant1	Ant2	
HE20	MCS0	2	1	2412	Full	-14.73	-14.74	-11.72	-2.77		8.00		Pass
HE20	MCS0	2	1	2412	26/0	-9.10	-8.87	-5.86	-2.77		8.00		Pass
HE20	MCS0	2	1	2412	52/37	-9.09	-8.88	-5.87	-2.77		8.00		Pass
HE20	MCS0	2	1	2412	106/53	-10.12	-9.76	-6.75	-2.77		8.00		Pass
HE20	MCS0	2	6	2437	Full	-13.13	-13.26	-10.12	-2.77		8.00		Pass
HE20	MCS0	2	6	2437	26/4	-9.49	-9.10	-6.09	-2.77		8.00		Pass
HE20	MCS0	2	6	2437	52/39	-9.25	-9.05	-6.04	-2.77		8.00		Pass
HE20	MCS0	2	6	2437	106/53	-9.56	-9.47	-6.46	-2.77		8.00		Pass
HE20	MCS0	2	11	2462	Full	-13.19	-13.28	-10.18	-2.77		8.00		Pass
HE20	MCS0	2	11	2462	26/8	-8.98	-9.21	-5.97	-2.77		8.00		Pass
HE20	MCS0	2	11	2462	52/40	-8.79	-8.45	-5.44	-2.77		8.00		Pass
HE20	MCS0	2	11	2462	106/54	-8.83	-9.03	-5.82	-2.77		8.00		Pass

Measured power density (dBm) has offset with cable loss.

TEST RESULTS DATA
Peak Output Power

2.4GHz Band Single Antenna																	
Mod.	Data Rate	Ntx	CH.	Freq. (MHz)	RU Config	Peak Conducted Power (dBm)			Conducted Power Limit (dBm)		DG (dBi)		EIRP Power (dBm)		EIRP Power Limit (dBm)		Pass /Fail
						Ant1	Ant2	SUM	Ant1	Ant2	Ant1	Ant2	Ant1	Ant2	Ant1	Ant2	
HE20	MCS0	1	1	2412	Full	22.90	23.20		30.00	30.00	-2.40	-11.40	20.50	11.80	36.00	36.00	Pass
HE20	MCS0	1	1	2412	26/0	22.50	22.87		30.00	30.00	-2.40	-11.40	20.10	11.47	36.00	36.00	Pass
HE20	MCS0	1	1	2412	52/37	24.00	24.62		30.00	30.00	-2.40	-11.40	21.60	13.22	36.00	36.00	Pass
HE20	MCS0	1	1	2412	106/53	24.20	24.00		30.00	30.00	-2.40	-11.40	21.80	12.60	36.00	36.00	Pass
HE20	MCS0	1	6	2437	Full	23.50	24.00		30.00	30.00	-2.40	-11.40	21.10	12.60	36.00	36.00	Pass
HE20	MCS0	1	6	2437	26/4	21.30	21.50		30.00	30.00	-2.40	-11.40	18.90	10.10	36.00	36.00	Pass
HE20	MCS0	1	6	2437	52/39	23.45	24.20		30.00	30.00	-2.40	-11.40	21.05	12.80	36.00	36.00	Pass
HE20	MCS0	1	6	2437	106/53	23.75	24.40		30.00	30.00	-2.40	-11.40	21.35	13.00	36.00	36.00	Pass
HE20	MCS0	1	11	2462	Full	23.20	23.95		30.00	30.00	-2.40	-11.40	20.80	12.55	36.00	36.00	Pass
HE20	MCS0	1	11	2462	26/8	22.08	21.90		30.00	30.00	-2.40	-11.40	19.68	10.50	36.00	36.00	Pass
HE20	MCS0	1	11	2462	52/40	23.50	24.45		30.00	30.00	-2.40	-11.40	21.10	13.05	36.00	36.00	Pass
HE20	MCS0	1	11	2462	106/54	23.70	24.20		30.00	30.00	-2.40	-11.40	21.30	12.80	36.00	36.00	Pass

2.4GHz Band MIMO																	
Mod.	Data Rate	Ntx	CH.	Freq. (MHz)	RU Config	Peak Conducted Power (dBm)			Conducted Power Limit (dBm)		DG (dBi)		EIRP Power (dBm)		EIRP Power Limit (dBm)		Pass /Fail
						Ant1	Ant2	SUM	Ant1	Ant2	Ant1	Ant2	Ant1	Ant2	Ant1	Ant2	
HE20	MCS0	2	1	2412	Full	22.93	23.22	26.09	30.00		-2.40		23.69		36.00		Pass
HE20	MCS0	2	1	2412	26/0	22.53	22.90	25.73	30.00		-2.40		23.33		36.00		Pass
HE20	MCS0	2	1	2412	52/37	24.02	24.63	27.35	30.00		-2.40		24.95		36.00		Pass
HE20	MCS0	2	1	2412	106/53	24.22	24.03	27.14	30.00		-2.40		24.74		36.00		Pass
HE20	MCS0	2	6	2437	Full	23.53	24.02	26.79	30.00		-2.40		24.39		36.00		Pass
HE20	MCS0	2	6	2437	26/4	21.33	21.53	24.44	30.00		-2.40		22.04		36.00		Pass
HE20	MCS0	2	6	2437	52/39	23.48	24.25	26.89	30.00		-2.40		24.49		36.00		Pass
HE20	MCS0	2	6	2437	106/53	23.78	24.43	27.13	30.00		-2.40		24.73		36.00		Pass
HE20	MCS0	2	11	2462	Full	23.23	23.97	26.63	30.00		-2.40		24.23		36.00		Pass
HE20	MCS0	2	11	2462	26/8	22.10	21.92	25.02	30.00		-2.40		22.62		36.00		Pass
HE20	MCS0	2	11	2462	52/40	23.53	24.48	27.04	30.00		-2.40		24.64		36.00		Pass
HE20	MCS0	2	11	2462	106/54	23.72	24.22	26.99	30.00		-2.40		24.59		36.00		Pass

Note: Measured power (dBm) has offset with cable loss.

TEST RESULTS DATA
Average Output Power (Reporting Only)

2.4GHz Band Single Antenna																	
Mod.	Data Rate	N _{Tx}	CH.	Freq. (MHz)	RU Config	Average Conducted Power (dBm)			Conducted Power Limit (dBm)		DG (dBi)		EIRP Power (dBm)		EIRP Power Limit (dBm)		Pass /Fail
						Ant1	Ant2	SUM	Ant1	Ant2	Ant1	Ant2	Ant1	Ant2	Ant1	Ant2	
HE20	MCS0	1	1	2412	Full	12.80	12.70		30.00	30.00	-2.40	-11.40	10.40	1.30	36.00	36.00	Pass
HE20	MCS0	1	1	2412	26/0	9.10	9.20		30.00	30.00	-2.40	-11.40	6.70	-2.20	36.00	36.00	Pass
HE20	MCS0	1	1	2412	52/37	12.10	12.10		30.00	30.00	-2.40	-11.40	9.70	0.70	36.00	36.00	Pass
HE20	MCS0	1	1	2412	106/53	14.30	13.60		30.00	30.00	-2.40	-11.40	11.90	2.20	36.00	36.00	Pass
HE20	MCS0	1	6	2437	Full	14.60	13.80		30.00	30.00	-2.40	-11.40	12.20	2.40	36.00	36.00	Pass
HE20	MCS0	1	6	2437	26/4	9.10	9.10		30.00	30.00	-2.40	-11.40	6.70	-2.30	36.00	36.00	Pass
HE20	MCS0	1	6	2437	52/39	12.30	12.30		30.00	30.00	-2.40	-11.40	9.90	0.90	36.00	36.00	Pass
HE20	MCS0	1	6	2437	106/53	14.30	13.80		30.00	30.00	-2.40	-11.40	11.90	2.40	36.00	36.00	Pass
HE20	MCS0	1	11	2462	Full	13.80	13.80		30.00	30.00	-2.40	-11.40	11.40	2.40	36.00	36.00	Pass
HE20	MCS0	1	11	2462	26/8	9.30	9.10		30.00	30.00	-2.40	-11.40	6.90	-2.30	36.00	36.00	Pass
HE20	MCS0	1	11	2462	52/40	12.30	12.30		30.00	30.00	-2.40	-11.40	9.90	0.90	36.00	36.00	Pass
HE20	MCS0	1	11	2462	106/54	14.30	13.60		30.00	30.00	-2.40	-11.40	11.90	2.20	36.00	36.00	Pass

2.4GHz Band MIMO																	
Mod.	Data Rate	N _{Tx}	CH.	Freq. (MHz)	RU Config	Average Conducted Power (dBm)			Conducted Power Limit (dBm)		DG (dBi)		EIRP Power (dBm)		EIRP Power Limit (dBm)		Pass /Fail
						Ant1	Ant2	SUM	Ant1	Ant2	Ant1	Ant2	Ant1	Ant2	Ant1	Ant2	
HE20	MCS0	2	1	2412	Full	12.90	12.80	15.86	30.00		-2.40		13.46		36.00		Pass
HE20	MCS0	2	1	2412	26/0	9.20	9.40	12.31	30.00		-2.40		9.91		36.00		Pass
HE20	MCS0	2	1	2412	52/37	12.20	12.40	15.31	30.00		-2.40		12.91		36.00		Pass
HE20	MCS0	2	1	2412	106/53	14.40	13.90	17.17	30.00		-2.40		14.77		36.00		Pass
HE20	MCS0	2	6	2437	Full	14.70	13.90	17.33	30.00		-2.40		14.93		36.00		Pass
HE20	MCS0	2	6	2437	26/4	9.20	9.40	12.31	30.00		-2.40		9.91		36.00		Pass
HE20	MCS0	2	6	2437	52/39	12.40	12.40	15.41	30.00		-2.40		13.01		36.00		Pass
HE20	MCS0	2	6	2437	106/53	14.40	13.90	17.17	30.00		-2.40		14.77		36.00		Pass
HE20	MCS0	2	11	2462	Full	13.90	13.90	16.91	30.00		-2.40		14.51		36.00		Pass
HE20	MCS0	2	11	2462	26/8	9.40	9.30	12.36	30.00		-2.40		9.96		36.00		Pass
HE20	MCS0	2	11	2462	52/40	12.40	12.40	15.41	30.00		-2.40		13.01		36.00		Pass
HE20	MCS0	2	11	2462	106/54	14.40	13.90	17.17	30.00		-2.40		14.77		36.00		Pass

Note: Measured power (dBm) has offset with cable loss.

TEST RESULTS DATA
6dB and 99% Occupied Bandwidth

2.4GHz Band MIMO											
Mod.	Data Rate	N _{TX}	CH.	Freq. (MHz)	RU Config	99% Occupied BW (MHz)		6dB BW (MHz)		6dB BW Limit (MHz)	Pass/Fail
						Ant1	Ant2	Ant1	Ant2		
HE20	MCS0	1	1	2412	Full	19.05	19.00	18.94	18.79	0.50	Pass
HE20	MCS0	1	1	2412	26/0	18.55	18.40	2.07	2.00	0.50	Pass
HE20	MCS0	1	1	2412	52/37	18.45	18.25	17.05	16.93	0.50	Pass
HE20	MCS0	1	1	2412	106/53	18.45	18.25	18.10	17.10	0.50	Pass
HE20	MCS0	1	6	2437	Full	19.10	19.10	19.02	18.94	0.50	Pass
HE20	MCS0	1	11	2462	Full	19.15	19.10	18.92	18.96	0.50	Pass
HE20	MCS0	1	11	2462	26/8	18.75	18.35	2.02	1.99	0.50	Pass
HE20	MCS0	1	11	2462	52/40	18.55	18.35	16.92	14.46	0.50	Pass
HE20	MCS0	1	11	2462	106/54	18.50	18.35	17.09	17.10	0.50	Pass

<Simultaneous Mode>

Test Engineer:	Howard Lin	Temperature:	21~25	°C
Test Date:	2020/1/15~2020/2/20	Relative Humidity:	51~54	%

2.4GHz Band Single Antenna																
Mod.	Data Rate	NTX	CH.	Freq. (MHz)	Peak Conducted Power (dBm)			Conducted Power Limit (dBm)		DG (dBi)		EIRP Power (dBm)		EIRP Power Limit (dBm)		Pass /Fail
					Ant1	Ant2	SUM	Ant1	Ant2	Ant1	Ant2	Ant1	Ant2	Ant1	Ant2	
11b	1Mbps	1	1	2412	15.44	13.90		30.00	30.00	-2.40	-11.40	13.04	2.50	36.00	36.00	Pass
11b	1Mbps	1	6	2437	15.31	13.80		30.00	30.00	-2.40	-11.40	12.91	2.40	36.00	36.00	Pass
11b	1Mbps	1	11	2462	15.33	13.49		30.00	30.00	-2.40	-11.40	12.93	2.09	36.00	36.00	Pass
11g	6Mbps	1	1	2412	20.41	19.20		30.00	30.00	-2.40	-11.40	18.01	7.80	36.00	36.00	Pass
11g	6Mbps	1	6	2437	21.10	20.10		30.00	30.00	-2.40	-11.40	18.70	8.70	36.00	36.00	Pass
11g	6Mbps	1	11	2462	20.20	20.10		30.00	30.00	-2.40	-11.40	17.80	8.70	36.00	36.00	Pass
HT20	MCS0	1	1	2412	20.99	20.20		30.00	30.00	-2.40	-11.40	18.59	8.80	36.00	36.00	Pass
HT20	MCS0	1	6	2437	21.05	19.70		30.00	30.00	-2.40	-11.40	18.65	8.30	36.00	36.00	Pass
HT20	MCS0	1	11	2462	20.30	19.70		30.00	30.00	-2.40	-11.40	17.90	8.30	36.00	36.00	Pass

2.4GHz Band MIMO																
Mod.	Data Rate	NTX	CH.	Freq. (MHz)	Peak Conducted Power (dBm)			Conducted Power Limit (dBm)		DG (dBi)		EIRP Power (dBm)		EIRP Power Limit (dBm)		Pass /Fail
					Ant1	Ant2	SUM	Ant1	Ant2	Ant1	Ant2	Ant1	Ant2	Ant1	Ant2	
11b	1Mbps	2	1	2412	15.45	13.91	17.76	30.00	30.00	-2.40	-11.40	15.36	2.50	36.00	36.00	Pass
11b	1Mbps	2	6	2437	15.33	13.81	17.65	30.00	30.00	-2.40	-11.40	15.25	2.40	36.00	36.00	Pass
11b	1Mbps	2	11	2462	15.35	13.50	17.53	30.00	30.00	-2.40	-11.40	15.13	2.09	36.00	36.00	Pass
11g	6Mbps	2	1	2412	20.40	20.00	23.21	30.00	30.00	-2.40	-11.40	20.81	7.80	36.00	36.00	Pass
11g	6Mbps	2	6	2437	20.70	20.81	23.77	30.00	30.00	-2.40	-11.40	21.37	8.70	36.00	36.00	Pass
11g	6Mbps	2	11	2462	20.70	20.70	23.71	30.00	30.00	-2.40	-11.40	21.31	8.70	36.00	36.00	Pass
HT20	MCS0	2	1	2412	20.90	20.30	23.62	30.00	30.00	-2.40	-11.40	21.22	8.80	36.00	36.00	Pass
HT20	MCS0	2	6	2437	20.60	20.20	23.41	30.00	30.00	-2.40	-11.40	21.01	8.30	36.00	36.00	Pass
HT20	MCS0	2	11	2462	20.20	20.34	23.28	30.00	30.00	-2.40	-11.40	20.88	8.30	36.00	36.00	Pass

Note: Measured power (dBm) has offset with cable loss.

2.4GHz Band Single Antenna																	
Mod.	Data Rate	N _{TX}	CH.	Freq. (MHz)	RU Config	Peak Conducted Power (dBm)			Conducted Power Limit (dBm)		DG (dBi)		EIRP Power (dBm)		EIRP Power Limit (dBm)		Pass /Fail
						Ant1	Ant2	SUM	Ant1	Ant2	Ant1	Ant2	Ant1	Ant2	Ant1	Ant2	
HE20	MCS0	1	1	2412	Full	23.00	22.61		30.00	30.00	-2.40	-11.40	20.60	11.21	36.00	36.00	Pass
HE20	MCS0	1	6	2437	Full	23.30	22.55		30.00	30.00	-2.40	-11.40	20.90	11.15	36.00	36.00	Pass
HE20	MCS0	1	11	2462	Full	22.60	22.50		30.00	30.00	-2.40	-11.40	20.20	11.10	36.00	36.00	Pass

2.4GHz Band MIMO																	
Mod.	Data Rate	N _{TX}	CH.	Freq. (MHz)	RU Config	Peak Conducted Power (dBm)			Conducted Power Limit (dBm)		DG (dBi)		EIRP Power (dBm)		EIRP Power Limit (dBm)		Pass /Fail
						Ant1	Ant2	SUM	Ant1	Ant2	Ant1	Ant2	Ant1	Ant2	Ant1	Ant2	
HE20	MCS0	2	1	2412	Full	23.19	22.20	25.73	30.00	30.00	-2.40	-2.40	23.33	23.33	36.00	36.00	Pass
HE20	MCS0	2	6	2437	Full	23.30	22.10	25.75	30.00	30.00	-2.40	-2.40	23.35	23.35	36.00	36.00	Pass
HE20	MCS0	2	11	2462	Full	23.10	22.00	25.60	30.00	30.00	-2.40	-2.40	23.20	23.20	36.00	36.00	Pass

Note: Measured power (dBm) has offset with cable loss.

2.4GHz Band Single Antenna																
Mod.	Data Rate	NTX	CH.	Freq. (MHz)	Average Conducted Power (dBm)			Conducted Power Limit (dBm)		DG (dBi)		EIRP Power (dBm)		EIRP Power Limit (dBm)		Pass /Fail
					Ant1	Ant2	SUM	Ant1	Ant2	Ant1	Ant2	Ant1	Ant2	Ant1	Ant2	
11b	1Mbps	1	1	2412	12.70	10.80		30.00	30.00	-2.40	-11.40	10.30	-0.60	36.00	36.00	Pass
11b	1Mbps	1	6	2437	12.60	10.80		30.00	30.00	-2.40	-11.40	10.20	-0.60	36.00	36.00	Pass
11b	1Mbps	1	11	2462	12.60	10.80		30.00	30.00	-2.40	-11.40	10.20	-0.60	36.00	36.00	Pass
11g	6Mbps	1	1	2412	12.80	11.80		30.00	30.00	-2.40	-11.40	10.40	0.40	36.00	36.00	Pass
11g	6Mbps	1	6	2437	12.90	11.90		30.00	30.00	-2.40	-11.40	10.50	0.50	36.00	36.00	Pass
11g	6Mbps	1	11	2462	12.80	11.90		30.00	30.00	-2.40	-11.40	10.40	0.50	36.00	36.00	Pass
HT20	MCS0	1	1	2412	12.80	11.80		30.00	30.00	-2.40	-11.40	10.40	0.40	36.00	36.00	Pass
HT20	MCS0	1	6	2437	12.90	11.80		30.00	30.00	-2.40	-11.40	10.50	0.40	36.00	36.00	Pass
HT20	MCS0	1	11	2462	12.90	11.90		30.00	30.00	-2.40	-11.40	10.50	0.50	36.00	36.00	Pass

2.4GHz Band MIMO																
Mod.	Data Rate	NTX	CH.	Freq. (MHz)	Average Conducted Power (dBm)			Conducted Power Limit (dBm)		DG (dBi)		EIRP Power (dBm)		EIRP Power Limit (dBm)		Pass /Fail
					Ant1	Ant2	SUM	Ant1	Ant2	Ant1	Ant2	Ant1	Ant2	Ant1	Ant2	
11b	1Mbps	2	1	2412	12.80	10.90	14.96	30.00		-2.40		12.56		36.00		Pass
11b	1Mbps	2	6	2437	12.70	10.90	14.90	30.00		-2.40		12.50		36.00		Pass
11b	1Mbps	2	11	2462	12.70	10.90	14.90	30.00		-2.40		12.50		36.00		Pass
11g	6Mbps	2	1	2412	12.90	11.90	15.44	30.00		-2.40		13.04		36.00		Pass
11g	6Mbps	2	6	2437	13.00	12.00	15.54	30.00		-2.40		13.14		36.00		Pass
11g	6Mbps	2	11	2462	12.90	12.00	15.48	30.00		-2.40		13.08		36.00		Pass
HT20	MCS0	2	1	2412	12.90	11.90	15.44	30.00		-2.40		13.04		36.00		Pass
HT20	MCS0	2	6	2437	13.00	11.90	15.50	30.00		-2.40		13.10		36.00		Pass
HT20	MCS0	2	11	2462	13.00	12.00	15.54	30.00		-2.40		13.14		36.00		Pass

Note: Measured power (dBm) has offset with cable loss.

2.4GHz Band Single Antenna																	
Mod.	Data Rate	N _{TX}	CH.	Freq. (MHz)	RU Config	Average Conducted Power (dBm)			Conducted Power Limit (dBm)		DG (dBi)		EIRP Power (dBm)		EIRP Power Limit (dBm)		Pass /Fail
						Ant1	Ant2	SUM	Ant1	Ant2	Ant1	Ant2	Ant1	Ant2	Ant1	Ant2	
HE20	MCS0	1	1	2412	Full	12.80	11.80		30.00	30.00	-2.40	-11.40	10.40	0.40	36.00	36.00	Pass
HE20	MCS0	1	6	2437	Full	12.70	11.80		30.00	30.00	-2.40	-11.40	10.30	0.40	36.00	36.00	Pass
HE20	MCS0	1	11	2462	Full	12.80	11.70		30.00	30.00	-2.40	-11.40	10.40	0.30	36.00	36.00	Pass

2.4GHz Band MIMO																	
Mod.	Data Rate	N _{TX}	CH.	Freq. (MHz)	RU Config	Average Conducted Power (dBm)			Conducted Power Limit (dBm)		DG (dBi)		EIRP Power (dBm)		EIRP Power Limit (dBm)		Pass /Fail
						Ant1	Ant2	SUM	Ant1	Ant2	Ant1	Ant2	Ant1	Ant2	Ant1	Ant2	
HE20	MCS0	2	1	2412	Full	12.90	11.90	15.44	30.00	30.00	-2.40	-11.40	13.04	0.40	36.00	36.00	Pass
HE20	MCS0	2	6	2437	Full	12.80	11.90	15.38	30.00	30.00	-2.40	-11.40	12.98	0.40	36.00	36.00	Pass
HE20	MCS0	2	11	2462	Full	12.90	11.80	15.40	30.00	30.00	-2.40	-11.40	13.00	0.40	36.00	36.00	Pass

Note: Measured power (dBm) has offset with cable loss.



Appendix B. AC Conducted Emission Test Results

Test Engineer :	Howard Huang and Tom Lee	Temperature :	22~25°C
		Relative Humidity :	45~52%

EUT Information

Report NO : 9O1542-02
 Test Mode : Mode 1
 Test Voltage : 120Vac/60Hz
 Phase : Line

Full Spectrum

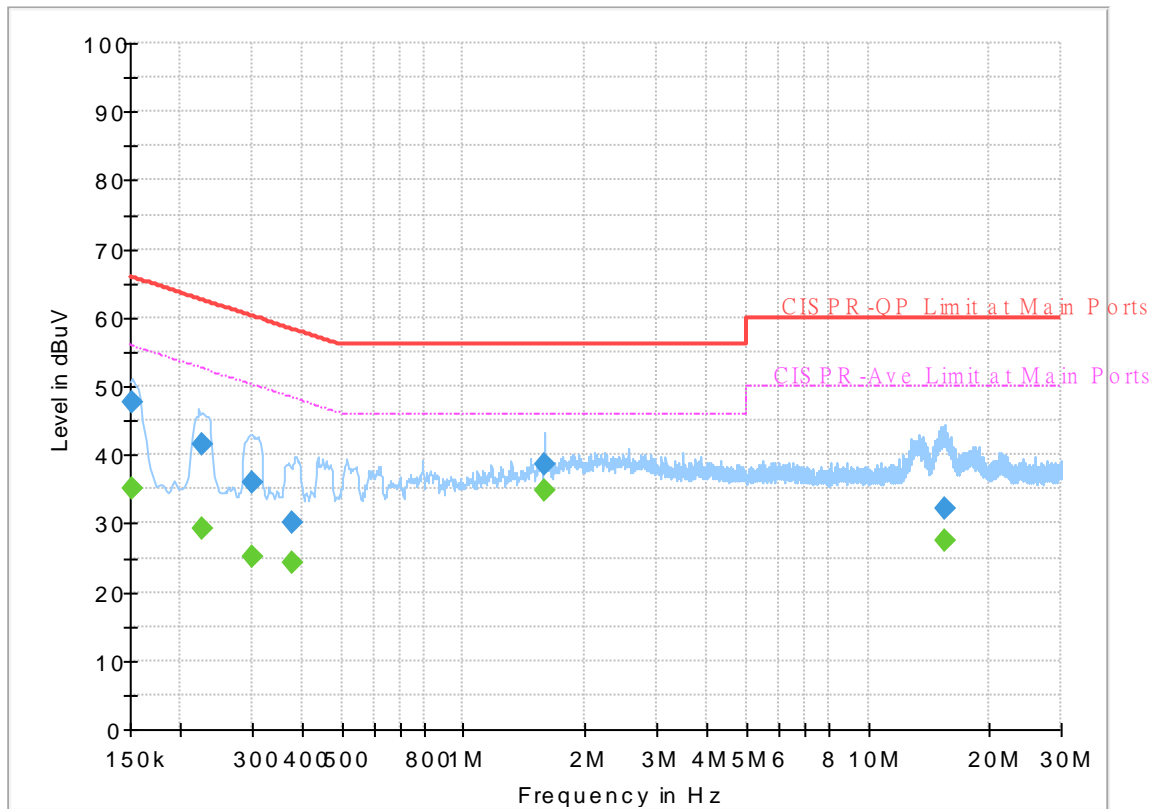

Final Result

Frequency (MHz)	QuasiPeak (dBuV)	CAverage (dBuV)	Limit (dBuV)	Margin (dB)	Line	Filter	Corr. (dB)
0.150878	---	35.14	55.95	20.81	L1	OFF	19.5
0.150878	47.61	---	65.95	18.34	L1	OFF	19.5
0.224970	---	29.16	52.63	23.47	L1	OFF	19.5
0.224970	41.40	---	62.63	21.23	L1	OFF	19.5
0.300750	---	25.12	50.22	25.10	L1	OFF	19.5
0.300750	35.94	---	60.22	24.28	L1	OFF	19.5
0.379500	---	24.29	48.29	24.00	L1	OFF	19.5
0.379500	30.06	---	58.29	28.23	L1	OFF	19.5
1.585320	---	34.77	46.00	11.23	L1	OFF	19.6
1.585320	38.73	---	56.00	17.27	L1	OFF	19.6
15.531000	---	27.45	50.00	22.55	L1	OFF	20.1
15.531000	32.23	---	60.00	27.77	L1	OFF	20.1

EUT Information

Report NO : 9O1542-02
 Test Mode : Mode 1
 Test Voltage : 120Vac/60Hz
 Phase : Neutral

Full Spectrum

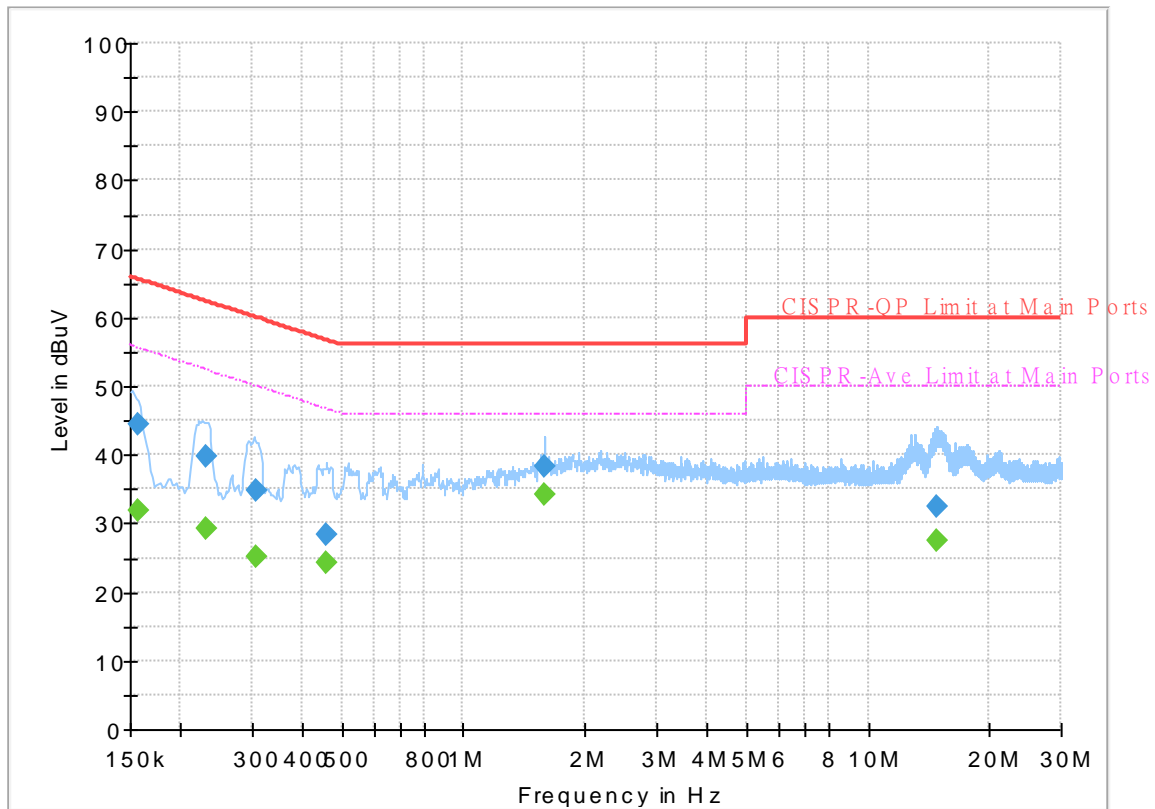

Final_Result

Frequency (MHz)	QuasiPeak (dBuV)	CAverage (dBuV)	Limit (dBuV)	Margin (dB)	Line	Filter	Corr. (dB)
0.156750	---	31.87	55.63	23.76	N	OFF	19.5
0.156750	44.30	---	65.63	21.33	N	OFF	19.5
0.231000	---	29.33	52.41	23.08	N	OFF	19.5
0.231000	39.67	---	62.41	22.74	N	OFF	19.5
0.305880	---	25.13	50.08	24.95	N	OFF	19.5
0.305880	34.71	---	60.08	25.37	N	OFF	19.5
0.456000	---	24.28	46.77	22.49	N	OFF	19.5
0.456000	28.50	---	56.77	28.27	N	OFF	19.5
1.585050	---	34.32	46.00	11.68	N	OFF	19.6
1.585050	38.41	---	56.00	17.59	N	OFF	19.6
14.820000	---	27.35	50.00	22.65	N	OFF	20.1
14.820000	32.54	---	60.00	27.46	N	OFF	20.1

EUT Information

Report NO : 901542-02
 Test Mode : Mode 2
 Test Voltage : 120Vac/60Hz
 Phase : Line

Full Spectrum

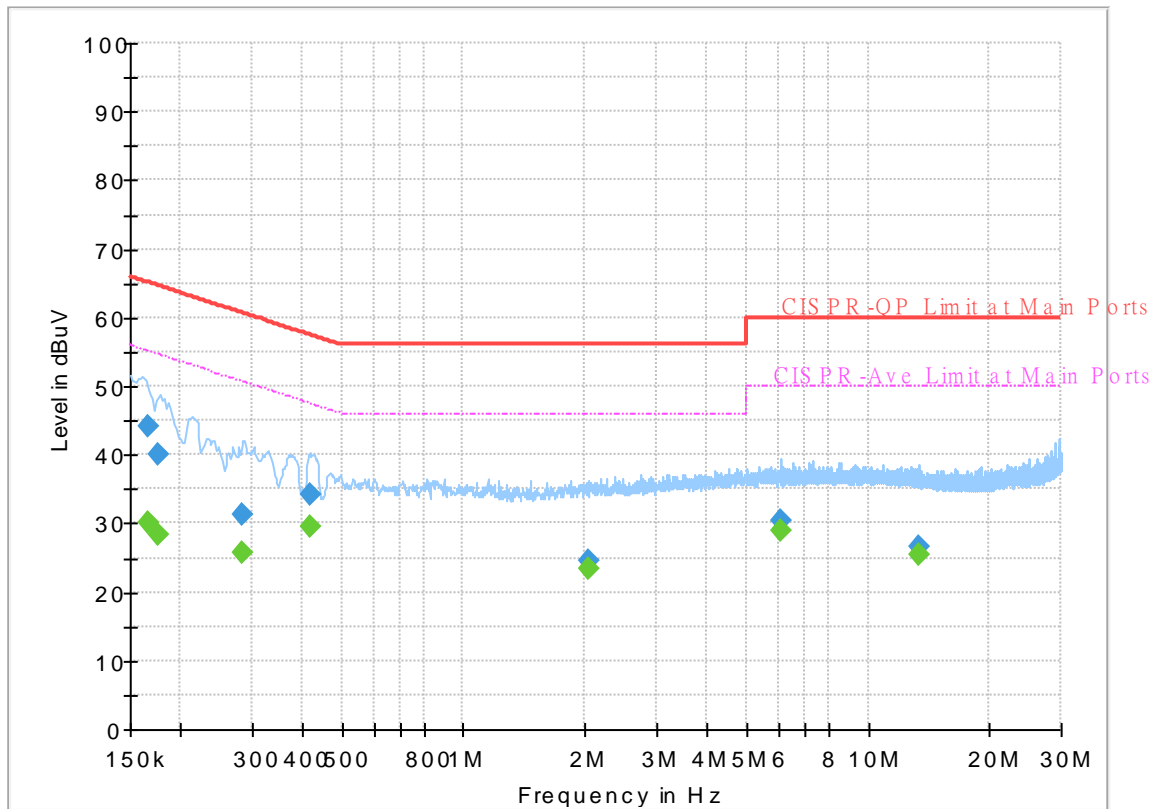

Final_Result

Frequency (MHz)	QuasiPeak (dBuV)	CAverage (dBuV)	Limit (dBuV)	Margin (dB)	Line	Filter	Corr. (dB)
0.165750	---	30.16	55.17	25.01	L1	OFF	19.5
0.165750	44.10	---	65.17	21.07	L1	OFF	19.5
0.176100	---	28.25	54.67	26.42	L1	OFF	19.5
0.176100	39.96	---	64.67	24.71	L1	OFF	19.5
0.285090	---	25.60	50.67	25.07	L1	OFF	19.5
0.285090	31.36	---	60.67	29.31	L1	OFF	19.5
0.419460	---	29.56	47.46	17.90	L1	OFF	19.5
0.419460	34.30	---	57.46	23.16	L1	OFF	19.5
2.036310	---	23.25	46.00	22.75	L1	OFF	19.7
2.036310	24.48	---	56.00	31.52	L1	OFF	19.7
6.056520	---	28.81	50.00	21.19	L1	OFF	19.8
6.056520	30.28	---	60.00	29.72	L1	OFF	19.8
13.328250	---	25.37	50.00	24.63	L1	OFF	20.1
13.328250	26.61	---	60.00	33.39	L1	OFF	20.1

EUT Information

Report NO : 901542-02
 Test Mode : Mode 2
 Test Voltage : 120Vac/60Hz
 Phase : Neutral

Full Spectrum

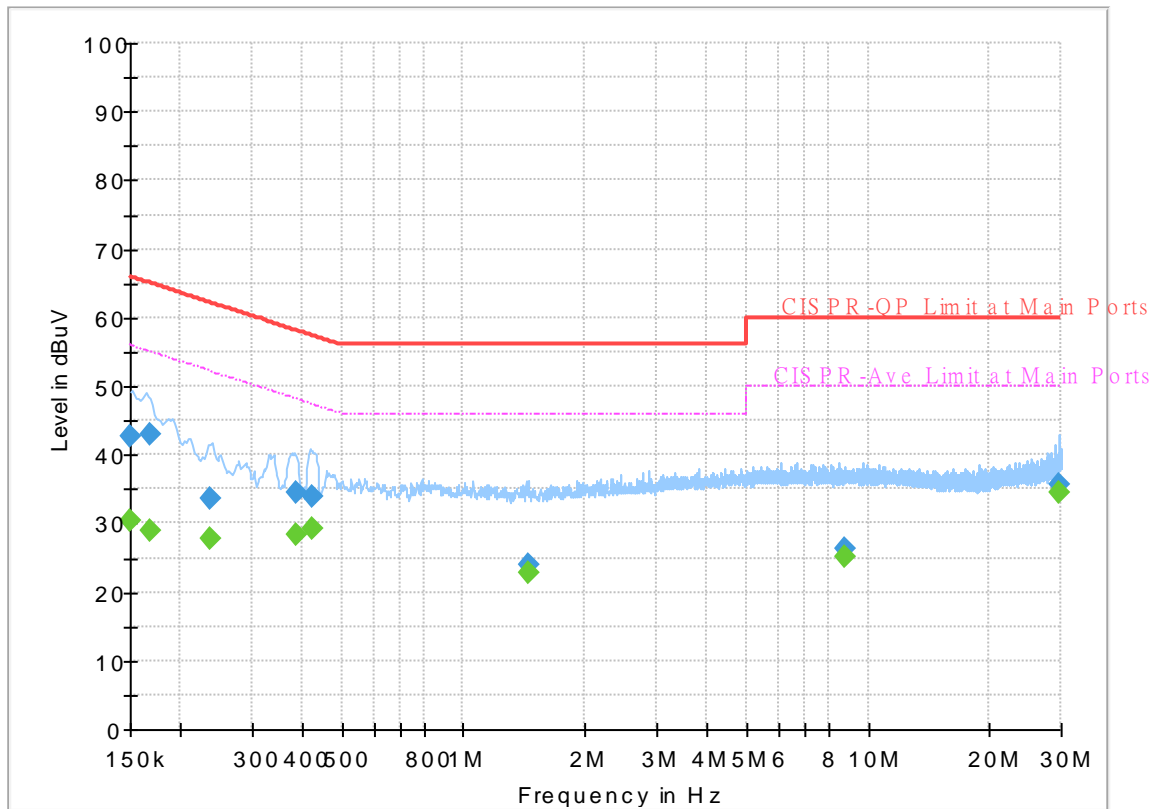

Final Result

Frequency (MHz)	QuasiPeak (dBuV)	CAverage (dBuV)	Limit (dBuV)	Margin (dB)	Line	Filter	Corr. (dB)
0.150000	---	30.28	56.00	25.72	N	OFF	19.6
0.150000	42.55	---	66.00	23.45	N	OFF	19.6
0.168000	---	28.87	55.06	26.19	N	OFF	19.6
0.168000	42.85	---	65.06	22.21	N	OFF	19.6
0.235500	---	27.84	52.25	24.41	N	OFF	19.6
0.235500	33.54	---	62.25	28.71	N	OFF	19.6
0.385890	---	28.48	48.15	19.67	N	OFF	19.6
0.385890	34.42	---	58.15	23.73	N	OFF	19.6
0.422250	---	29.25	47.40	18.15	N	OFF	19.6
0.422250	33.93	---	57.40	23.47	N	OFF	19.6
1.448070	---	22.72	46.00	23.28	N	OFF	19.6
1.448070	23.85	---	56.00	32.15	N	OFF	19.6
8.797290	---	25.13	50.00	24.87	N	OFF	20.0
8.797290	26.28	---	60.00	33.72	N	OFF	20.0
29.674860	---	34.49	50.00	15.51	N	OFF	20.7
29.674860	35.67	---	60.00	24.33	N	OFF	20.7



Appendix C. Radiated Spurious Emission

Test Engineer :	Jacky Hung, Andy Yang, and CR Liao	Temperature :	20~25°C
		Relative Humidity :	50~60%

2.4GHz 2400~2483.5MHz
WIFI 802.11b (Band Edge @ 3m)

WIFI	Note	Frequency	Level	Over	Limit	Read	Antenna	Path	Preamp	Ant	Table	Peak	Pol.	
Ant.				Limit	Line	Level	Factor	Loss	Factor	Pos	Pos	Avg.		
1+2		(MHz)	(dBµV/m)	(dB)	(dBµV/m)	(dBµV)	(dB/m)	(dB)	(dB)	(cm)	(deg)	(P/A)	(H/V)	
802.11b CH 01 2412MHz		2366.7	57.92	-16.08	74	41.9	27.73	18.06	29.77	148	34	P	H	
		2340.975	44.33	-9.67	54	28.24	27.84	18.01	29.76	148	34	A	H	
	*	2412	106.32	-	-	90.38	27.6	18.13	29.79	148	34	P	H	
	*	2412	103.27	-	-	87.33	27.6	18.13	29.79	148	34	A	H	
													H	
			2359.98	56.79	-17.21	74	40.76	27.76	18.04	29.77	399	107	P	V
			2352.105	44.26	-9.74	54	28.21	27.79	18.03	29.77	399	107	A	V
	*		2412	103.08	-	-	87.14	27.6	18.13	29.79	399	107	P	V
	*		2412	100.08	-	-	84.14	27.6	18.13	29.79	399	107	A	V
														V
802.11b CH 06 2437MHz		2344.02	57.03	-16.97	74	40.95	27.82	18.02	29.76	114	33	P	H	
		2346.54	44.3	-9.7	54	28.24	27.81	18.02	29.77	114	33	A	H	
	*	2437	106.28	-	-	90.31	27.6	18.17	29.8	114	33	P	H	
	*	2437	103.08	-	-	87.11	27.6	18.17	29.8	114	33	A	H	
			2491.67	56.42	-17.58	74	40.47	27.52	18.26	29.83	114	33	P	H
			2488.8	44.39	-9.61	54	28.45	27.52	18.25	29.83	114	33	A	H
			2370.9	57.05	-16.95	74	41.05	27.72	18.06	29.78	390	107	P	V
			2363.34	44.34	-9.66	54	28.31	27.75	18.05	29.77	390	107	A	V
	*		2437	103.16	-	-	87.19	27.6	18.17	29.8	390	107	P	V
	*		2437	99.98	-	-	84.01	27.6	18.17	29.8	390	107	A	V
			2497.76	55.81	-18.19	74	39.87	27.5	18.27	29.83	390	107	P	V
			2492.58	44.48	-9.52	54	28.54	27.51	18.26	29.83	390	107	A	V



802.11b CH 11 2462MHz	*	2462	107.36	-	-	91.38	27.58	18.21	29.81	139	35	P	H
	*	2462	104.25	-	-	88.27	27.58	18.21	29.81	139	35	A	H
		2492.56	56.24	-17.76	74	40.3	27.51	18.26	29.83	139	35	P	H
		2483.6	44.54	-9.46	54	28.59	27.53	18.24	29.82	139	35	A	H
													H
													H
	*	2462	102.84	-	-	86.86	27.58	18.21	29.81	389	107	P	V
	*	2462	99.68	-	-	83.7	27.58	18.21	29.81	389	107	A	V
		2484.72	56.51	-17.49	74	40.55	27.53	18.25	29.82	389	107	P	V
		2490.4	44.45	-9.55	54	28.51	27.52	18.25	29.83	389	107	A	V
													V
													V
Remark	1. No other spurious found. 2. All results are PASS against Peak and Average limit line.												



2.4GHz 2400~2483.5MHz
WIFI 802.11b (Harmonic @ 3m)

WIFI Ant. 1+2	Note	Frequency (MHz)	Level (dBμV/m)	Over Limit (dB)	Limit Line (dBμV/m)	Read Level (dBμV)	Antenna Factor (dB/m)	Path Loss (dB)	Preamp Factor (dB)	Ant Pos (cm)	Table Pos (deg)	Peak Avg. (P/A)	Pol. (H/V)	
802.11b CH 01 2412MHz		4824	37.05	-36.95	74	51.58	31.15	12.43	58.11	100	0	P	H	
													H	
													H	
													H	
			4824	37.06	-36.94	74	51.59	31.15	12.43	58.11	100	0	P	V
														V
														V
802.11b CH 06 2437MHz		4874	37.28	-36.72	74	51.82	31.1	12.48	58.12	100	0	P	H	
		7311	43.16	-30.84	74	48.54	36.44	15.68	57.5	100	0	P	H	
													H	
													H	
			4874	37.58	-36.42	74	52.12	31.1	12.48	58.12	100	0	P	V
			7311	44.14	-29.86	74	49.52	36.44	15.68	57.5	100	0	P	V
														V
802.11b CH 11 2462MHz		4924	37.12	-36.88	74	51.63	31.1	12.52	58.13	100	0	P	H	
		7386	42.77	-31.23	74	47.98	36.53	15.66	57.4	100	0	P	H	
													H	
													H	
			4924	37.23	-36.77	74	51.74	31.1	12.52	58.13	100	0	P	V
			7386	42.67	-31.33	74	47.88	36.53	15.66	57.4	100	0	P	V
														V
Remark	1. No other spurious found.													
	2. All results are PASS against Peak and Average limit line.													



**2.4GHz 2400~2483.5MHz
WIFI 802.11g (Band Edge @ 3m)**

WIFI Ant.	Note	Frequency	Level	Over Limit	Limit Line	Read Level	Antenna Factor	Path Loss	Preamp Factor	Ant Pos	Table Pos	Peak Avg.	Pol.	
1+2		(MHz)	(dBμV/m)	(dB)	(dBμV/m)	(dBμV)	(dB/m)	(dB)	(dB)	(cm)	(deg)	(P/A)	(H/V)	
802.11g CH 01 2412MHz		2350.005	57.58	-16.42	74	41.52	27.8	18.03	29.77	144	36	P	H	
		2390	44.77	-9.23	54	28.82	27.64	18.09	29.78	144	36	A	H	
	*	2412	106.64	-	-	90.7	27.6	18.13	29.79	144	36	P	H	
	*	2412	98.88	-	-	82.94	27.6	18.13	29.79	144	36	A	H	
													H	
													H	
			2378.04	57.18	-16.82	74	41.2	27.69	18.07	29.78	400	107	P	V
			2390	44.43	-9.57	54	28.48	27.64	18.09	29.78	400	107	A	V
	*		2412	101.95	-	-	86.01	27.6	18.13	29.79	400	107	P	V
	*		2412	93.81	-	-	77.87	27.6	18.13	29.79	400	107	A	V
													V	
													V	
802.11g CH 06 2437MHz		2323.02	57.02	-16.98	74	40.89	27.91	17.98	29.76	116	35	P	H	
		2316.02	44.48	-9.52	54	28.32	27.94	17.97	29.75	116	35	A	H	
	*	2437	108.33	-	-	92.36	27.6	18.17	29.8	116	35	P	H	
	*	2437	100.55	-	-	84.58	27.6	18.17	29.8	116	35	A	H	
			2498.95	56.24	-17.76	74	40.3	27.5	18.27	29.83	116	35	P	H
			2488.31	44.56	-9.44	54	28.62	27.52	18.25	29.83	116	35	A	H
			2315.74	56.69	-17.31	74	40.53	27.94	17.97	29.75	397	108	P	V
			2310.84	44.51	-9.49	54	28.34	27.96	17.96	29.75	397	108	A	V
	*		2437	103.42	-	-	87.45	27.6	18.17	29.8	397	108	P	V
	*		2437	95.82	-	-	79.85	27.6	18.17	29.8	397	108	A	V
			2493.7	56.25	-17.75	74	40.31	27.51	18.26	29.83	397	108	P	V
			2488.45	44.6	-9.4	54	28.66	27.52	18.25	29.83	397	108	A	V



802.11g CH 11 2462MHz	*	2462	106.99	-	-	91.01	27.58	18.21	29.81	110	35	P	H
	*	2462	99.17	-	-	83.19	27.58	18.21	29.81	110	35	A	H
		2487.4	56.9	-17.1	74	40.94	27.53	18.25	29.82	110	35	P	H
		2483.52	45.82	-8.18	54	29.87	27.53	18.24	29.82	110	35	A	H
													H
													H
	*	2462	103.16	-	-	87.18	27.58	18.21	29.81	389	107	P	V
	*	2462	95.26	-	-	79.28	27.58	18.21	29.81	389	107	A	V
		2491.52	56.97	-17.03	74	41.02	27.52	18.26	29.83	389	107	P	V
		2483.52	45.1	-8.9	54	29.15	27.53	18.24	29.82	389	107	A	V
													V
													V
Remark	<ol style="list-style-type: none"> 1. No other spurious found. 2. All results are PASS against Peak and Average limit line. 												



2.4GHz 2400~2483.5MHz
WIFI 802.11g (Harmonic @ 3m)

WIFI Ant. 1+2	Note	Frequency (MHz)	Level (dBμV/m)	Over Limit (dB)	Limit Line (dBμV/m)	Read Level (dBμV)	Antenna Factor (dB/m)	Path Loss (dB)	Preamp Factor (dB)	Ant Pos (cm)	Table Pos (deg)	Peak Avg. (P/A)	Pol. (H/V)	
802.11g CH 01 2412MHz		4824	36.44	-37.56	74	50.97	31.15	12.43	58.11	100	0	P	H	
													H	
													H	
													H	
			4824	36.7	-37.3	74	51.23	31.15	12.43	58.11	100	0	P	V
														V
														V
802.11g CH 06 2437MHz		4874	36.72	-37.28	74	51.26	31.1	12.48	58.12	100	0	P	H	
		7311	43.29	-30.71	74	48.67	36.44	15.68	57.5	100	0	P	H	
													H	
													H	
			4874	37.38	-36.62	74	51.92	31.1	12.48	58.12	100	0	P	V
			7311	43	-31	74	48.38	36.44	15.68	57.5	100	0	P	V
														V
802.11g CH 11 2462MHz		4924	37.61	-36.39	74	52.12	31.1	12.52	58.13	100	0	P	H	
		7386	43.32	-30.68	74	48.53	36.53	15.66	57.4	100	0	P	H	
													H	
													H	
			4924	37.25	-36.75	74	51.76	31.1	12.52	58.13	100	0	P	V
			7386	43.27	-30.73	74	48.48	36.53	15.66	57.4	100	0	P	V
														V
Remark	1. No other spurious found.													
	2. All results are PASS against Peak and Average limit line.													



**2.4GHz 2400~2483.5MHz
WIFI 802.11n HT20 (Band Edge @ 3m)**

WIFI Ant.	Note	Frequency (MHz)	Level (dBμV/m)	Over Limit (dB)	Limit Line (dBμV/m)	Read Level (dBμV)	Antenna Factor (dB/m)	Path Loss (dB)	Preamp Factor (dB)	Ant Pos (cm)	Table Pos (deg)	Peak Avg. (P/A)	Pol. (H/V)	
802.11n HT20 CH 01 2412MHz		2322.705	57.11	-16.89	74	40.98	27.91	17.98	29.76	148	34	P	H	
		2389.8	44.58	-9.42	54	28.63	27.64	18.09	29.78	148	34	A	H	
	*	2412	105.23	-	-	89.29	27.6	18.13	29.79	148	34	P	H	
	*	2412	96.53	-	-	80.59	27.6	18.13	29.79	148	34	A	H	
													H	
														H
			2313.465	57.15	-16.85	74	40.98	27.95	17.97	29.75	399	107	P	V
			2355.885	44.36	-9.64	54	28.31	27.78	18.04	29.77	399	107	A	V
		*	2412	102.51	-	-	86.57	27.6	18.13	29.79	399	107	P	V
		*	2412	94.06	-	-	78.12	27.6	18.13	29.79	399	107	A	V
													V	
													V	
802.11n HT20 CH 06 2437MHz		2366.28	56.41	-17.59	74	40.4	27.73	18.05	29.77	114	34	P	H	
		2325.54	44.4	-9.6	54	28.27	27.9	17.99	29.76	114	34	A	H	
	*	2437	106.61	-	-	90.64	27.6	18.17	29.8	114	34	P	H	
	*	2437	98.4	-	-	82.43	27.6	18.17	29.8	114	34	A	H	
			2491.81	57	-17	74	41.05	27.52	18.26	29.83	114	34	P	H
			2483.62	44.5	-9.5	54	28.55	27.53	18.24	29.82	114	34	A	H
			2386.72	56.74	-17.26	74	40.78	27.65	18.09	29.78	391	107	P	V
			2316.16	44.44	-9.56	54	28.28	27.94	17.97	29.75	391	107	A	V
		*	2437	103.54	-	-	87.57	27.6	18.17	29.8	391	107	P	V
		*	2437	95.69	-	-	79.72	27.6	18.17	29.8	391	107	A	V
		2485.09	56.28	-17.72	74	40.32	27.53	18.25	29.82	391	107	P	V	
		2491.53	44.53	-9.47	54	28.58	27.52	18.26	29.83	391	107	A	V	



802.11n HT20 CH 11 2462MHz	*	2462	105.5	-	-	89.52	27.58	18.21	29.81	145	33	P	H
	*	2462	97.27	-	-	81.29	27.58	18.21	29.81	145	33	A	H
		2484.12	58.48	-15.52	74	42.53	27.53	18.24	29.82	145	33	P	H
		2483.52	46.09	-7.91	54	30.14	27.53	18.24	29.82	145	33	A	H
													H
													H
	*	2462	101.99	-	-	86.01	27.58	18.21	29.81	390	106	P	V
	*	2462	94.29	-	-	78.31	27.58	18.21	29.81	390	106	A	V
		2494.32	56.54	-17.46	74	40.6	27.51	18.26	29.83	390	106	P	V
		2483.52	45.1	-8.9	54	29.15	27.53	18.24	29.82	390	106	A	V
													V
												V	
Remark	1. No other spurious found. 2. All results are PASS against Peak and Average limit line.												



**2.4GHz 2400~2483.5MHz
WIFI 802.11n HT20 (Harmonic @ 3m)**

WIFI Ant. 1+2	Note	Frequency (MHz)	Level (dBμV/m)	Over Limit (dB)	Limit Line (dBμV/m)	Read Level (dBμV)	Antenna Factor (dB/m)	Path Loss (dB)	Preamp Factor (dB)	Ant Pos (cm)	Table Pos (deg)	Peak Avg. (P/A)	Pol. (H/V)	
802.11n HT20 CH 01 2412MHz		4824	37.06	-36.94	74	51.59	31.15	12.43	58.11	100	0	P	H	
													H	
													H	
													H	
			4824	37.03	-36.97	74	51.56	31.15	12.43	58.11	100	0	P	V
														V
														V
802.11n HT20 CH 06 2437MHz		4874	36.68	-37.32	74	51.22	31.1	12.48	58.12	100	0	P	H	
													H	
			7311	43.47	-30.53	74	48.85	36.44	15.68	57.5	100	0	P	H
														H
														H
			4874	37.28	-36.72	74	51.82	31.1	12.48	58.12	100	0	P	V
			7311	43.51	-30.49	74	48.89	36.44	15.68	57.5	100	0	P	V
802.11n HT20 CH 11 2462MHz													V	
													V	
			4924	36.97	-37.03	74	51.48	31.1	12.52	58.13	100	0	P	H
			7386	44.09	-29.91	74	49.3	36.53	15.66	57.4	100	0	P	H
														H
														H
			4924	36.42	-37.58	74	50.93	31.1	12.52	58.13	100	0	P	V
		7386	43.16	-30.84	74	48.37	36.53	15.66	57.4	100	0	P	V	
Remark	1. No other spurious found.													
	2. All results are PASS against Peak and Average limit line.													



2.4GHz 2400~2483.5MHz

WIFI 802.11ax HE20 Full RU (Band Edge @ 3m)

WIFI	Note	Frequency	Level	Over	Limit	Read	Antenna	Path	Preamp	Ant	Table	Peak	Pol.	
Ant.				Limit	Line	Level	Factor	Loss	Factor	Pos	Pos	Avg.		
1+2		(MHz)	(dBμV/m)	(dB)	(dBμV/m)	(dBμV)	(dB/m)	(dB)	(dB)	(cm)	(deg)	(P/A)	(H/V)	
802.11ax HE20 Full RU CH 01 2412MHz		2327.64	56.72	-17.28	74	40.6	27.89	17.99	29.76	103	33	P	H	
		2390	44.21	-9.79	54	28.26	27.64	18.09	29.78	103	33	A	H	
	*	2412	106.29	-	-	90.35	27.6	18.13	29.79	103	33	P	H	
	*	2412	96.32	-	-	80.38	27.6	18.13	29.79	103	33	A	H	
													H	
													H	
			2342.13	56.45	-17.55	74	40.37	27.83	18.01	29.76	400	103	P	V
			2389.8	43.99	-10.01	54	28.04	27.64	18.09	29.78	400	103	A	V
	*		2412	102.58	-	-	86.64	27.6	18.13	29.79	400	103	P	V
	*		2412	93.85	-	-	77.91	27.6	18.13	29.79	400	103	A	V
													V	
													V	
802.11ax HE20 Full RU CH 06 2437MHz		2364.32	56.05	-17.95	74	40.03	27.74	18.05	29.77	114	33	P	H	
		2316.58	43.93	-10.07	54	27.78	27.93	17.97	29.75	114	33	A	H	
	*	2437	108.08	-	-	92.11	27.6	18.17	29.8	114	33	P	H	
	*	2437	98.44	-	-	82.47	27.6	18.17	29.8	114	33	A	H	
			2485.09	55.88	-18.12	74	39.92	27.53	18.25	29.82	114	33	P	H
			2499.3	44.05	-9.95	54	28.11	27.5	18.27	29.83	114	33	A	H
			2321.06	56.53	-17.47	74	40.38	27.92	17.98	29.75	397	103	P	V
			2310.98	43.85	-10.15	54	27.68	27.96	17.96	29.75	397	103	A	V
	*		2437	104.96	-	-	88.99	27.6	18.17	29.8	397	103	P	V
	*		2437	94.91	-	-	78.94	27.6	18.17	29.8	397	103	A	V
		2484.46	56.48	-17.52	74	40.52	27.53	18.25	29.82	397	103	P	V	
		2494.96	44	-10	54	28.06	27.51	18.26	29.83	397	103	A	V	



802.11ax HE20 Full RU CH 11 2462MHz	*	2462	108.28	-	-	92.3	27.58	18.21	29.81	109	50	P	H
	*	2462	98.02	-	-	82.04	27.58	18.21	29.81	109	50	A	H
		2484.84	58.22	-15.78	74	42.26	27.53	18.25	29.82	109	50	P	H
		2483.52	46.66	-7.34	54	30.71	27.53	18.24	29.82	109	50	A	H
													H
													H
	*	2462	103.72	-	-	87.74	27.58	18.21	29.81	390	105	P	V
	*	2462	93.49	-	-	77.51	27.58	18.21	29.81	390	105	A	V
		2486.56	56.08	-17.92	74	40.12	27.53	18.25	29.82	390	105	P	V
		2483.52	45.17	-8.83	54	29.22	27.53	18.24	29.82	390	105	A	V
													V
													V
Remark	1. No other spurious found. 2. All results are PASS against Peak and Average limit line.												



2.4GHz 2400~2483.5MHz

WIFI 802.11ax HE20 Full RU (Harmonic @ 3m)

WIFI Ant. 1+2	Note	Frequency (MHz)	Level (dBμV/m)	Over Limit (dB)	Limit Line (dBμV/m)	Read Level (dBμV)	Antenna Factor (dB/m)	Path Loss (dB)	Preamp Factor (dB)	Ant Pos (cm)	Table Pos (deg)	Peak Avg. (P/A)	Pol. (H/V)	
802.11ax HE20 Full CH 01 2412MHz		4824	36.72	-37.28	74	51.23	31.15	12.45	58.11	100	0	P	H	
													H	
													H	
													H	
			4824	36.96	-37.04	74	51.47	31.15	12.45	58.11	100	0	P	V
														V
														V
802.11ax HE20 Full 2437MHz		4874	35.59	-38.41	74	50.11	31.1	12.5	58.12	100	0	P	H	
		7311	42.24	-31.76	74	47.7	36.44	15.6	57.5	100	0	P	H	
													H	
													H	
			4874	36.08	-37.92	74	50.6	31.1	12.5	58.12	100	4874	P	V
			7311	41.99	-32.01	74	47.45	36.44	15.6	57.5	100	7311	P	V
														V
802.11ax HE20 Full 2462MHz		4924	35.72	-38.28	74	50.22	31.1	12.53	58.13	100	0	P	H	
		7386	41.72	-32.28	74	46.99	36.53	15.6	57.4	100	0	P	H	
													H	
													H	
			4924	37.44	-36.56	74	51.94	31.1	12.53	58.13	100	0	P	V
			7386	42.01	-31.99	74	47.28	36.53	15.6	57.4	100	0	P	V
														V
Remark	1. No other spurious found.													
	2. All results are PASS against Peak and Average limit line.													



2.4GHz 2400~2483.5MHz

WIFI 802.11ax HE20 Partial RU (26 Tone) (Band Edge @ 3m)

WIFI Ant. 1+2	Note	Frequency (MHz)	Level (dBμV/m)	Over Limit (dB)	Limit Line (dBμV/m)	Read Level (dBμV)	Antenna Factor (dB/m)	Path Loss (dB)	Preamp Factor (dB)	Ant Pos (cm)	Table Pos (deg)	Peak Avg. (P/A)	Pol. (H/V)	
802.11ax HE20 Partial RU 26/0 RU CH 01 2412MHz		2389.38	56.82	-17.18	74	40.87	27.64	18.09	29.78	318	339	P	H	
		2311.995	43.96	-10.04	54	27.8	27.95	17.96	29.75	318	339	A	H	
	*	2412	107.39	-	-	91.45	27.6	18.13	29.79	318	339	P	H	
	*	2412	99.27	-	-	83.33	27.6	18.13	29.79	318	339	A	H	
													H	
														H
			2366.7	57.78	-16.22	74	41.76	27.73	18.06	29.77	285	16	P	V
			2315.985	43.96	-10.04	54	27.8	27.94	17.97	29.75	285	16	A	V
		*	2412	112.23	-	-	96.29	27.6	18.13	29.79	285	16	P	V
		*	2412	103.24	-	-	87.3	27.6	18.13	29.79	285	16	A	V
													V	
													V	
802.11ax HE20 Partial RU 26/8 RU CH 11 2462MHz	*	2462	106.05	-	-	90.07	27.58	18.21	29.81	306	337	P	H	
	*	2462	98.07	-	-	82.09	27.58	18.21	29.81	306	337	A	H	
		2500	57.3	-16.7	74	41.36	27.5	18.27	29.83	306	337	P	H	
		2491.88	44.08	-9.92	54	28.13	27.52	18.26	29.83	306	337	A	H	
													H	
													H	
		*	2462	112.64	-	-	96.66	27.58	18.21	29.81	300	14	P	V
		*	2462	103.7	-	-	87.72	27.58	18.21	29.81	300	14	A	V
			2489.6	57.36	-16.64	74	41.42	27.52	18.25	29.83	300	14	P	V
			2483.52	44.13	-9.87	54	28.18	27.53	18.24	29.82	300	14	A	V
													V	
													V	
Remark	1. No other spurious found. 2. All results are PASS against Peak and Average limit line.													



2.4GHz 2400~2483.5MHz

WIFI 802.11ax HE20 Partial RU (26 Tone) (Harmonic @ 3m)

WIFI Ant. 1+2	Note	Frequency (MHz)	Level (dBμV/m)	Over Limit (dB)	Limit Line (dBμV/m)	Read Level (dBμV)	Antenna Factor (dB/m)	Path Loss (dB)	Preamp Factor (dB)	Ant Pos (cm)	Table Pos (deg)	Peak Avg. (P/A)	Pol. (H/V)
802.11ax HE20 Partial RU 26/0 RU CH 01 2412MHz		4824	36.39	-37.61	74	50.9	31.15	12.45	58.11	100	0	P	H
													H
													H
													H
802.11ax HE20 Partial RU 26/8 RU CH 11 2462MHz		4824	36.77	-37.23	74	51.28	31.15	12.45	58.11	100	0	P	V
													V
													V
													V
		4924	36.64	-37.36	74	51.14	31.1	12.53	58.13	100	0	P	H
		7386	42.67	-31.33	74	47.94	36.53	15.6	57.4	100	0	P	H
													H
													H
802.11ax HE20 Partial RU 26/8 RU CH 11 2462MHz		4924	35.88	-38.12	74	50.38	31.1	12.53	58.13	100	0	P	V
		7386	43.26	-30.74	74	48.53	36.53	15.6	57.4	100	0	P	V
													V
													V
Remark	1. No other spurious found. 2. All results are PASS against Peak and Average limit line.												



2.4GHz 2400~2483.5MHz

WIFI 802.11ax HE20 Partial RU (52 Tone) (Band Edge @ 3m)

WIFI Ant.	Note	Frequency (MHz)	Level (dBμV/m)	Over Limit (dB)	Limit Line (dBμV/m)	Read Level (dBμV)	Antenna Factor (dB/m)	Path Loss (dB)	Preamp Factor (dB)	Ant Pos (cm)	Table Pos (deg)	Peak Avg. (P/A)	Pol. (H/V)	
802.11ax HE20 Partial RU 52/37 RU CH 01 2412MHz		2359.35	56.91	-17.09	74	40.88	27.76	18.04	29.77	400	355	P	H	
		2313.78	43.96	-10.04	54	27.8	27.94	17.97	29.75	400	355	A	H	
	*	2412	110.64	-	-	94.7	27.6	18.13	29.79	400	355	P	H	
	*	2412	100.8	-	-	84.86	27.6	18.13	29.79	400	355	A	H	
													H	
														H
			2344.125	58.21	-15.79	74	42.13	27.82	18.02	29.76	355	27	P	V
			2319.765	43.98	-10.02	54	27.83	27.92	17.98	29.75	355	27	A	V
	*		2412	113.38	-	-	97.44	27.6	18.13	29.79	355	27	P	V
	*		2412	103.43	-	-	87.49	27.6	18.13	29.79	355	27	A	V
													V	
													V	
802.11ax HE20 Partial RU 52/40 RU CH 11 2462MHz	*	2462	109.93	-	-	93.95	27.58	18.21	29.81	345	23	P	H	
	*	2462	99.83	-	-	83.85	27.58	18.21	29.81	345	23	A	H	
		2498.4	57.66	-16.34	74	41.72	27.5	18.27	29.83	345	23	P	H	
		2483.6	44.08	-9.92	54	28.13	27.53	18.24	29.82	345	23	A	H	
														H
														H
	*		2462	113.51	-	-	97.53	27.58	18.21	29.81	303	8	P	V
	*		2462	103.34	-	-	87.36	27.58	18.21	29.81	303	8	A	V
			2483.72	59.46	-14.54	74	43.51	27.53	18.24	29.82	303	8	P	V
			2483.8	44.29	-9.71	54	28.34	27.53	18.24	29.82	303	8	A	V
													V	
													V	
Remark	1. No other spurious found.													
	2. All results are PASS against Peak and Average limit line.													



2.4GHz 2400~2483.5MHz

WIFI 802.11ax HE20 Partial RU (52 Tone) (Harmonic @ 3m)

WIFI Ant. 1+2	Note	Frequency (MHz)	Level (dBμV/m)	Over Limit (dB)	Limit Line (dBμV/m)	Read Level (dBμV)	Antenna Factor (dB/m)	Path Loss (dB)	Preamp Factor (dB)	Ant Pos (cm)	Table Pos (deg)	Peak Avg. (P/A)	Pol. (H/V)
802.11ax HE20 Partial RU 52/37 RU CH 01 2412MHz		4824	37.51	-36.49	74	52.02	31.15	12.45	58.11	100	0	P	H
													H
													H
													H
802.11ax HE20 Partial RU 52/40 RU CH 11 2462MHz		4824	36.69	-37.31	74	51.2	31.15	12.45	58.11	100	0	P	V
													V
													V
													V
		4924	36.44	-37.56	74	50.94	31.1	12.53	58.13	100	0	P	H
		7386	42.5	-31.5	74	47.77	36.53	15.6	57.4	100	0	P	H
Remark	1. No other spurious found.												
	2. All results are PASS against Peak and Average limit line.												



**2.4GHz 2400~2483.5MHz
WIFI 802.11ax HE20 Partial RU (106 Tone) (Band Edge @ 3m)**

WIFI Ant.	Note	Frequency (MHz)	Level (dBμV/m)	Over Limit (dB)	Limit Line (dBμV/m)	Read Level (dBμV)	Antenna Factor (dB/m)	Path Loss (dB)	Preamp Factor (dB)	Ant Pos (cm)	Table Pos (deg)	Peak Avg. (P/A)	Pol. (H/V)	
802.11ax HE20 Partial RU 106/53 RU CH 01 2412MHz		2315.46	56.94	-17.06	74	40.78	27.94	17.97	29.75	400	354	P	H	
		2390	43.99	-10.01	54	28.04	27.64	18.09	29.78	400	354	A	H	
	*	2412	110.55	-	-	94.61	27.6	18.13	29.79	400	354	P	H	
	*	2412	100.72	-	-	84.78	27.6	18.13	29.79	400	354	A	H	
													H	
														H
			2367.855	57.5	-16.5	74	41.48	27.73	18.06	29.77	315	29	P	V
			2389.485	44.08	-9.92	54	28.13	27.64	18.09	29.78	315	29	A	V
		*	2412	112.77	-	-	96.83	27.6	18.13	29.79	315	29	P	V
		*	2412	102.77	-	-	86.83	27.6	18.13	29.79	315	29	A	V
													V	
													V	
802.11ax HE20 Partial RU 106/54 RU CH 11 2462MHz	*	2462	107.97	-	-	91.99	27.58	18.21	29.81	345	22	P	H	
	*	2462	98.07	-	-	82.09	27.58	18.21	29.81	345	22	A	H	
		2495.84	57.73	-16.27	74	41.79	27.51	18.26	29.83	345	22	P	H	
		2485.28	44.1	-9.9	54	28.14	27.53	18.25	29.82	345	22	A	H	
														H
														H
		*	2462	111.91	-	-	95.93	27.58	18.21	29.81	335	25	P	V
		*	2462	102.06	-	-	86.08	27.58	18.21	29.81	335	25	A	V
			2485.04	59.6	-14.4	74	43.64	27.53	18.25	29.82	335	25	P	V
			2483.52	44.43	-9.57	54	28.48	27.53	18.24	29.82	335	25	A	V
													V	
													V	
Remark	1. No other spurious found.													
	2. All results are PASS against Peak and Average limit line.													



2.4GHz 2400~2483.5MHz

WIFI 802.11ax HE20 Partial RU (106 Tone) (Harmonic @ 3m)

WIFI Ant. 1+2	Note	Frequency (MHz)	Level (dBμV/m)	Over Limit (dB)	Limit Line (dBμV/m)	Read Level (dBμV)	Antenna Factor (dB/m)	Path Loss (dB)	Preamp Factor (dB)	Ant Pos (cm)	Table Pos (deg)	Peak Avg. (P/A)	Pol. (H/V)
802.11ax HE20 Partial RU 106/53 RU CH 01 2412MHz		4824	36.12	-37.88	74	50.63	31.15	12.45	58.11	100	0	P	H
													H
													H
													H
802.11ax HE20 Partial RU 106/54 RU CH 11 2462MHz		4824	37.45	-36.55	74	51.96	31.15	12.45	58.11	100	0	P	V
													V
													V
													V
802.11ax HE20 Partial RU 106/54 RU CH 11 2462MHz		4924	37.71	-36.29	74	52.21	31.1	12.53	58.13	100	0	P	H
		7386	43.53	-30.47	74	48.8	36.53	15.6	57.4	100	0	P	H
													H
													H
802.11ax HE20 Partial RU 106/54 RU CH 11 2462MHz		4924	36.52	-37.48	74	51.02	31.1	12.53	58.13	100	0	P	V
		7386	43.58	-30.42	74	48.85	36.53	15.6	57.4	100	0	P	V
													V
													V
Remark	<ol style="list-style-type: none"> No other spurious found. All results are PASS against Peak and Average limit line. 												



Emission above 1GHz

2.4GHz WIFI 802.11ax HE20 Full RU (SHF)

WIFI	Note	Frequency	Level	Over	Limit	Read	Antenna	Path	Preamp	Ant	Table	Peak	Pol.	
Ant.				Limit	Line	Level	Factor	Loss	Factor	Pos	Pos	Avg.		
1+2		(MHz)	(dBμV/m)	(dB)	(dBμV/m)	(dBμV)	(dB/m)	(dB)	(dB)	(cm)	(deg)	(P/A)	(H/V)	
2.4GHz 802.11ax HE20 Full RU		19113	39.28	-34.72	74	44.58	38.01	11.02	54.33	150	0	P	H	
													H	
													H	
													H	
													H	
													H	
														V
														V
														V
														V
Remark	1. No other spurious found.													
	2. All results are PASS against limit line.													



Emission below 1GHz

2.4GHz WIFI 802.11ax HE20 Full RU (LF)

WIFI	Note	Frequency	Level	Over	Limit	Read	Antenna	Path	Preamp	Ant	Table	Peak	Pol.	
Ant.				Limit	Line	Level	Factor	Loss	Factor	Pos	Pos	Avg.		
1+2		(MHz)	(dBμV/m)	(dB)	(dBμV/m)	(dBμV)	(dB/m)	(dB)	(dB)	(cm)	(deg)	(P/A)	(H/V)	
2.4GHz 802.11ax HE20 Full RU		43.58	32.68	-7.32	40	46.56	17.38	1.09	32.35	100	0	P	H	
		227.88	21.18	-24.82	46	34.81	16.07	2.63	32.33	-	-	P	H	
		378.23	22.25	-23.75	46	30.12	21.04	3.32	32.23	-	-	P	H	
		433.52	24.8	-21.2	46	30.53	22.87	3.56	32.16	-	-	P	H	
		637.22	29.29	-16.71	46	30.61	26.37	4.32	32.01	-	-	P	H	
		781.75	30.84	-15.16	46	30.23	28.13	4.81	32.33	-	-	P	H	
														H
														H
														H
														H
														H
														H
														H
			109.54	29.77	-13.73	43.5	43.5	16.73	1.8	32.26	100	0	P	V
			229.82	23.16	-22.84	46	36.6	16.25	2.64	32.33	-	-	P	V
			410.24	23.34	-22.66	46	29.79	22.26	3.48	32.19	-	-	P	V
			521.79	25.82	-20.18	46	30	24	3.87	32.05	-	-	P	V
			616.85	29.41	-16.59	46	31.46	25.64	4.27	31.96	-	-	P	V
		838.98	31.07	-14.93	46	29.4	28.88	4.98	32.19	-	-	P	V	
													V	
													V	
													V	
													V	
													V	
													V	
Remark	1. No other spurious found. 2. All results are PASS against limit line.													



<WPC Mode>

2.4GHz 2400~2483.5MHz

WIFI 802.11ax HE20 Full RU (Band Edge @ 3m)

WIFI	Note	Frequency	Level	Over	Limit	Read	Antenna	Path	Preamp	Ant	Table	Peak	Pol.
Ant.				Limit	Line	Level	Factor	Loss	Factor	Pos	Pos	Avg.	
1+2		(MHz)	(dBμV/m)	(dB)	(dBμV/m)	(dBμV)	(dB/m)	(dB)	(dB)	(cm)	(deg)	(P/A)	(H/V)
802.11ax HE20 Full RU CH 11 2462MHz	*	2462	105.39	-	-	89.41	27.58	18.21	29.81	100	42	P	H
	*	2462	96.79	-	-	80.81	27.58	18.21	29.81	100	42	A	H
		2484.36	58.26	-15.74	74	42.31	27.53	18.24	29.82	100	42	P	H
		2483.52	46.6	-7.4	54	30.65	27.53	18.24	29.82	100	42	A	H
													H
													H
	*	2462	102.52	-	-	86.54	27.58	18.21	29.81	100	266	P	V
	*	2462	94.07	-	-	78.09	27.58	18.21	29.81	100	266	A	V
		2492.24	58.37	-15.63	74	42.42	27.52	18.26	29.83	100	266	P	V
		2483.52	45.52	-8.48	54	29.57	27.53	18.24	29.82	100	266	A	V
													V
												V	
Remark	1. No other spurious found. 2. All results are PASS against Peak and Average limit line.												



2.4GHz 2400~2483.5MHz

WIFI 802.11ax HE20 Full RU (Harmonic @ 3m)

WIFI Ant. 1+2	Note	Frequency (MHz)	Level (dBμV/m)	Over Limit (dB)	Limit Line (dBμV/m)	Read Level (dBμV)	Antenna Factor (dB/m)	Path Loss (dB)	Preamp Factor (dB)	Ant Pos (cm)	Table Pos (deg)	Peak Avg. (P/A)	Pol. (H/V)	
802.11ax HE20 Full CH 11 2462MHz		4924	36.67	-37.33	74	51.18	31.1	12.52	58.13	100	0	P	H	
		7386	43.36	-30.64	74	48.57	36.53	15.66	57.4	100	0	P	H	
													H	
													H	
			4924	36.67	-37.33	74	51.18	31.1	12.52	58.13	100	0	P	V
			7386	44.72	-29.28	74	49.93	36.53	15.66	57.4	100	0	P	V
														V
														V
Remark	1. No other spurious found. 2. All results are PASS against Peak and Average limit line.													



Emission below 1GHz

2.4GHz WIFI 802.11ax HE20 Full RU (LF)

WIFI Ant. 1+2	Note	Frequency (MHz)	Level (dBμV/m)	Over Limit (dB)	Limit Line (dBμV/m)	Read Level (dBμV)	Antenna Factor (dB/m)	Path Loss (dB)	Preamp Factor (dB)	Ant Pos (cm)	Table Pos (deg)	Peak Avg. (P/A)	Pol. (H/V)	
2.4GHz 802.11ax HE20 Full RU LF		32.91	23.2	-16.8	40	31.48	22	0.96	32.23	-	-	P	H	
		72.68	22.42	-17.58	40	40.98	12.35	1.44	32.35	-	-	P	H	
		148.34	28.39	-15.11	43.5	41.48	17.04	2.15	32.28	-	-	P	H	
		308.39	26.28	-19.72	46	36.23	19.33	3.08	32.35	-	-	P	H	
		564.47	29.04	-16.96	46	30.82	26.13	4.08	31.98	-	-	P	H	
		956.35	33.51	-12.49	46	28.54	30.9	5.32	31.26	100	0	P	H	
														H
														H
														H
														H
														H
														H
														H
			32.91	28.4	-11.6	40	36.68	22.99	0.96	32.23	100	313	QP	V
			72.68	28.81	-11.19	40	47.37	12.35	1.44	32.35	-	-	P	V
			181.32	25.58	-17.92	43.5	40.7	14.84	2.35	32.31	-	-	P	V
			190.05	25.58	-17.92	43.5	40.8	14.69	2.4	32.31	-	-	P	V
			561.56	28.02	-17.98	46	29.78	26.17	4.06	31.99	-	-	P	V
			952.47	33.7	-12.3	46	28.88	30.8	5.32	31.3	-	-	P	V
														V
													V	
													V	
													V	
													V	
													V	
Remark	1. No other spurious found. 2. All results are PASS against limit line.													



Note symbol

*	Fundamental Frequency which can be ignored. However, the level of any unwanted emissions shall not exceed the level of the fundamental frequency.
!	Test result is over limit line.
P/A	Peak or Average
H/V	Horizontal or Vertical



A calculation example for radiated spurious emission is shown as below:

WIFI	Note	Frequency	Level	Over	Limit	Read	Antenna	Path	Preamp	Ant	Table	Peak	Pol.
Ant.				Limit	Line	Level	Factor	Loss	Factor	Pos	Pos	Avg.	
0+1		(MHz)	(dBμV/m)	(dB)	(dBμV/m)	(dBμV)	(dB/m)	(dB)	(dB)	(cm)	(deg)	(P/A)	(H/V)
802.11b		2390	55.45	-18.55	74	54.51	32.22	4.58	35.86	103	308	P	H
CH 01													
2412MHz		2390	43.54	-10.46	54	42.6	32.22	4.58	35.86	103	308	A	H

1. Path Loss(dB) = Cable loss(dB) + Filter loss(dB) + Attenuator loss(dB)
2. Level(dBμV/m) =
Antenna Factor(dB/m) + Path Loss(dB) + Read Level(dBμV) - Preamp Factor(dB)
3. Over Limit(dB) = Level(dBμV/m) – Limit Line(dBμV/m)

For Peak Limit @ 2390MHz:

1. Level(dBμV/m)
= Antenna Factor(dB/m) + Path Loss(dB) + Read Level(dBμV) - Preamp Factor(dB)
= 32.22(dB/m) + 4.58(dB) + 54.51(dBμV) – 35.86 (dB)
= 55.45 (dBμV/m)
2. Over Limit(dB)
= Level(dBμV/m) – Limit Line(dBμV/m)
= 55.45(dBμV/m) – 74(dBμV/m)
= -18.55(dB)

For Average Limit @ 2390MHz:

1. Level(dBμV/m)
= Antenna Factor(dB/m) + Path Loss(dB) + Read Level(dBμV) - Preamp Factor(dB)
= 32.22(dB/m) + 4.58(dB) + 42.6(dBμV) – 35.86 (dB)
= 43.54 (dBμV/m)
2. Over Limit(dB)
= Level(dBμV/m) – Limit Line(dBμV/m)
= 43.54(dBμV/m) – 54(dBμV/m)
= -10.46(dB)

Both peak and average measured complies with the limit line, so test result is “PASS”.



Appendix D. Radiated Spurious Emission

Test Engineer :	Jacky Hung, Andy Yang, and CR Liao	Temperature :	20~25°C
		Relative Humidity :	50~60%

Note symbol

-L	Low channel location
-R	High channel location

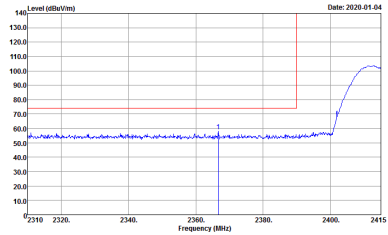
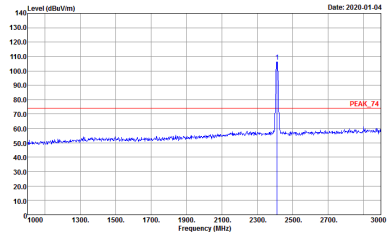
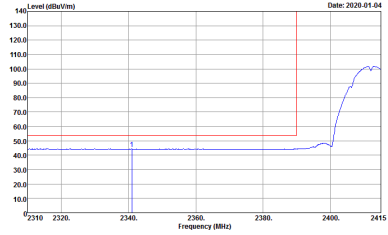
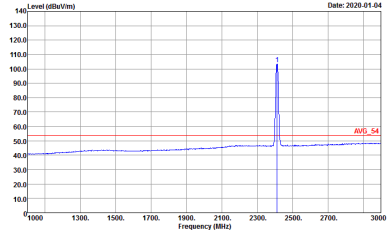

2.4GHz 2400~2483.5MHz
WIFI 802.11b (Band Edge @ 3m)

WIFI	2.4GHz 2400~2483.5MHz Band Edge @ 3m	
ANT	802.11b CH01 2412MHz	
1+2	Horizontal	Fundamental
Peak	 <p>Site : 03CH16-HY Condition : PEAK_BE_74 3m 91200_1522 HORIZONTAL Detector : Peak Project : 901542-02</p>	 <p>Site : 03CH16-HY Condition : PEAK_74 3m 91200_1522 HORIZONTAL Detector : Peak Project : 901542-02</p>
Avg.	 <p>Site : 03CH16-HY Condition : AVG_BE_54 3m 91200_1522 HORIZONTAL Detector : Peak Project : 901542-02</p>	 <p>Site : 03CH16-HY Condition : AVG_54 3m 91200_1522 HORIZONTAL Detector : Peak Project : 901542-02</p>



WIFI	2.4GHz 2400~2483.5MHz Band Edge @ 3m	
ANT	802.11b CH01 2412MHz	
1+2	Vertical	Fundamental
<p>Peak</p>	<p>Site : 03CH16-HY Condition : PEAK_8E_74 3m 91200_1522 VERTICAL RBW:1000.000KHz VBW:3000.000KHz SWT:Auto Detector : Peak Project : 901542-02</p>	<p>Site : 03CH16-HY Condition : PEAK_74 3m 91200_1522 VERTICAL RBW:1000.000KHz VBW:3000.000KHz SWT:Auto Detector : Peak Project : 901542-02</p>
<p>Avg.</p>	<p>Site : 03CH16-HY Condition : AVG_8E_54 3m 91200_1522 VERTICAL RBW:1000.000KHz VBW:0.010KHz SWT:Auto Detector : Peak Project : 901542-02</p>	<p>Site : 03CH16-HY Condition : AVG_54 3m 91200_1522 VERTICAL RBW:1000.000KHz VBW:0.010KHz SWT:Auto Detector : Peak Project : 901542-02</p>

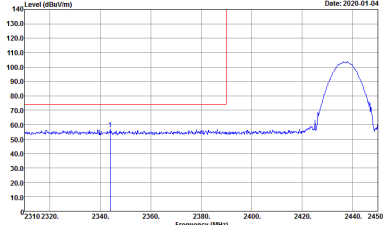
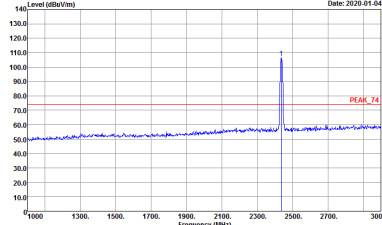
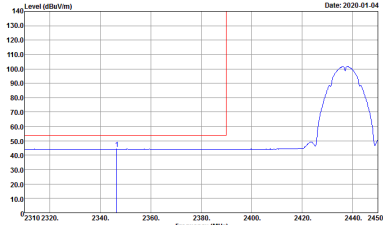
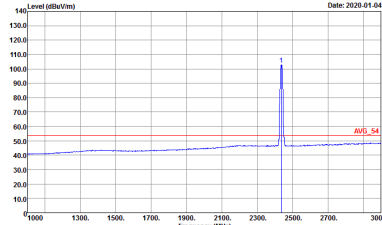

WIFI	2.4GHz 2400~2483.5MHz Band Edge @ 3m	
ANT	802.11b CH06 2437MHz - L	
1+2	Horizontal	Fundamental
<p>Peak</p>	 <p>Site : 03CH16-HY Condition : PEAK_BE_74 3m 91200_1522 HORIZONTAL RBW:1000.000KHz VBW:3000.000KHz SWT:Auto Detector : Peak Project : 901542-02</p>	 <p>Site : 03CH16-HY Condition : PEAK_74 3m 91200_1522 HORIZONTAL RBW:1000.000KHz VBW:3000.000KHz SWT:Auto Detector : Peak Project : 901542-02</p>
<p>Avg.</p>	 <p>Site : 03CH16-HY Condition : AVG_BE_54 3m 91200_1522 HORIZONTAL RBW:1000.000KHz VBW:0.010KHz SWT:Auto Detector : Peak Project : 901542-02</p>	 <p>Site : 03CH16-HY Condition : AVG_54 3m 91200_1522 HORIZONTAL RBW:1000.000KHz VBW:0.010KHz SWT:Auto Detector : Peak Project : 901542-02</p>

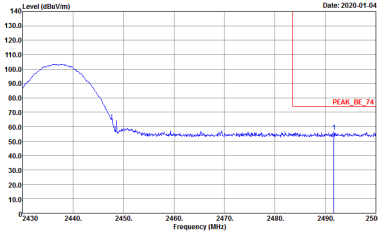
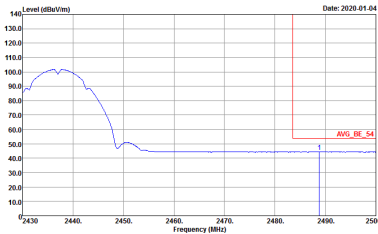

WIFI	2.4GHz 2400~2483.5MHz Band Edge @ 3m	
ANT	802.11b CH06 2437MHz - R	
1+2	Horizontal	Fundamental
<p>Peak</p>	 <p>Site : 03CH16-HY Condition : PEAK_BE_74 3m 91200_1522 HORIZONTAL RBW:1000.000kHz VBW:3000.000kHz SWF:Auto Detector : Peak Project : 901542-02</p>	<p>Left blank</p>
<p>Avg.</p>	 <p>Site : 03CH16-HY Condition : AVG_BE_54 3m 91200_1522 HORIZONTAL RBW:1000.000kHz VBW:0.010kHz SWF:Auto Detector : Peak Project : 901542-02</p>	<p>Left blank</p>



WIFI	2.4GHz 2400~2483.5MHz Band Edge @ 3m	
ANT	802.11b CH06 2437MHz - L	
1+2	Vertical	Fundamental
Peak	<p>Site : 03CH16-HY Condition : PEAK_8E_74 3m 91200_1522 VERTICAL RBW:1000.000KHz VBW:3000.000KHz SWT:Auto Detector : Peak Project : 901542-02</p>	<p>Site : 03CH16-HY Condition : PEAK_74 3m 91200_1522 VERTICAL RBW:1000.000KHz VBW:3000.000KHz SWT:Auto Detector : Peak Project : 901542-02</p>
Avg.	<p>Site : 03CH16-HY Condition : AVG_8E_54 3m 91200_1522 VERTICAL RBW:1000.000KHz VBW:0.010KHz SWT:Auto Detector : Peak Project : 901542-02</p>	<p>Site : 03CH16-HY Condition : AVG_54 3m 91200_1522 VERTICAL RBW:1000.000KHz VBW:0.010KHz SWT:Auto Detector : Peak Project : 901542-02</p>

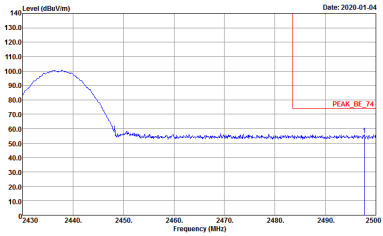
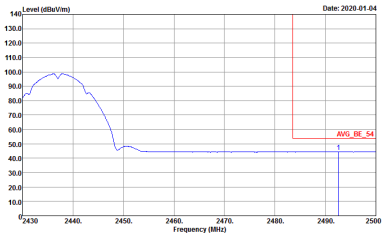

WIFI	2.4GHz 2400~2483.5MHz Band Edge @ 3m	
ANT	802.11b CH06 2437MHz - R	
1+2	Vertical	Fundamental
<p>Peak</p>	 <p>Site : 03CH16-HY Condition : PEAK_BE_74 3m 91200_1522 VERTICAL RBW:1000.000kHz VBW:3000.000kHz SWF:Auto Detector : Peak Project : 901542-02</p>	<p>Left blank</p>
<p>Avg.</p>	 <p>Site : 03CH16-HY Condition : AVG_BE_54 3m 91200_1522 VERTICAL RBW:1000.000kHz VBW:0.010kHz SWF:Auto Detector : Peak Project : 901542-02</p>	<p>Left blank</p>

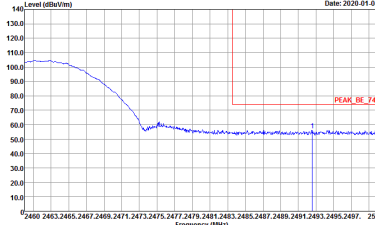
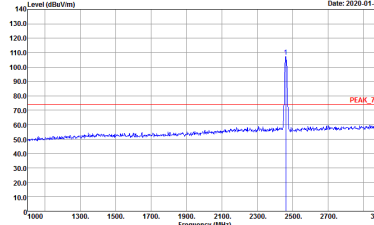
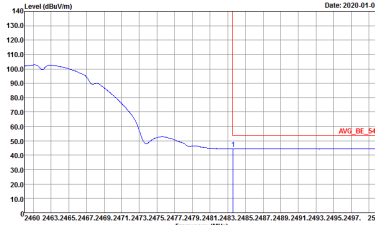
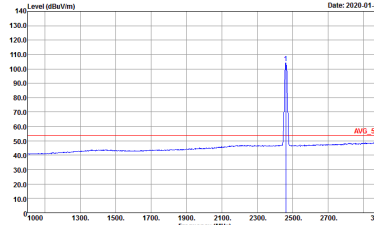

WIFI	2.4GHz 2400~2483.5MHz Band Edge @ 3m	
ANT	802.11b CH11 2462MHz	
1+2	Horizontal	Fundamental
<p>Peak</p>	 <p>Site : 03CH16-HY Condition : PEAK_BE_74 3m 91200_1522 HORIZONTAL RBW:1000.000KHz VBW:3000.000KHz SWT:Auto Detector : Peak Project : 901542-02</p>	 <p>Site : 03CH16-HY Condition : PEAK_74 3m 91200_1522 HORIZONTAL RBW:1000.000KHz VBW:3000.000KHz SWT:Auto Detector : Peak Project : 901542-02</p>
<p>Avg.</p>	 <p>Site : 03CH16-HY Condition : AVG_BE_54 3m 91200_1522 HORIZONTAL RBW:1000.000KHz VBW:0.010KHz SWT:Auto Detector : Peak Project : 901542-02</p>	 <p>Site : 03CH16-HY Condition : AVG_54 3m 91200_1522 HORIZONTAL RBW:1000.000KHz VBW:0.010KHz SWT:Auto Detector : Peak Project : 901542-02</p>

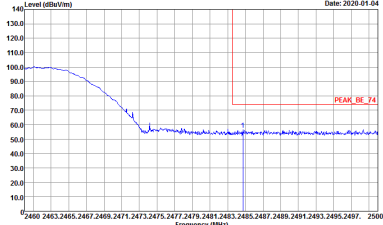
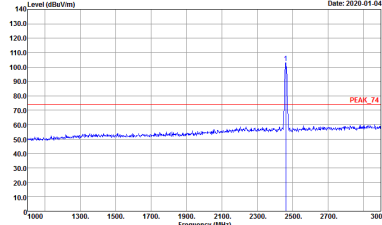
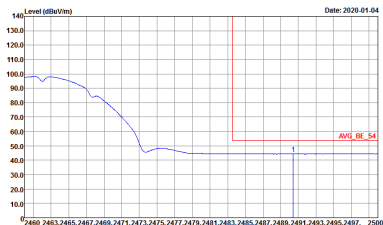
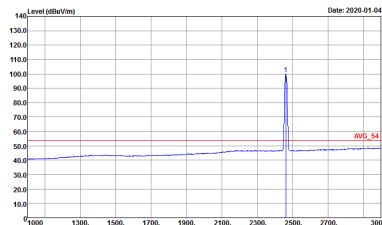

WIFI	2.4GHz 2400~2483.5MHz Band Edge @ 3m	
ANT	802.11b CH11 2462MHz	
1+2	Vertical	Fundamental
<p>Peak</p>	 <p>Site : 03CH16-HY Condition : PEAK_BE_74 3m 91200_1522 VERTICAL RBW:1000.000KHz VBW:3000.000KHz SWT:Auto Detector : Peak Project : 901542-02</p>	 <p>Site : 03CH16-HY Condition : PEAK_74 3m 91200_1522 VERTICAL RBW:1000.000KHz VBW:3000.000KHz SWT:Auto Detector : Peak Project : 901542-02</p>
<p>Avg.</p>	 <p>Site : 03CH16-HY Condition : AVG_BE_54 3m 91200_1522 VERTICAL RBW:1000.000KHz VBW:0.010KHz SWT:Auto Detector : Peak Project : 901542-02</p>	 <p>Site : 03CH16-HY Condition : AVG_54 3m 91200_1522 VERTICAL RBW:1000.000KHz VBW:0.010KHz SWT:Auto Detector : Peak Project : 901542-02</p>



2.4GHz 2400~2483.5MHz
WIFI 802.11g (Band Edge @ 3m)

WIFI	2.4GHz 2400~2483.5MHz Band Edge @ 3m	
ANT	802.11g CH01 2412MHz	
1+2	Horizontal	Fundamental
Peak	<p>Site : 03CH16-HY Condition : PEAK_BE_74 3m 91200_1522 HORIZONTAL Detector : Peak Project : 901542-02</p>	<p>Site : 03CH16-HY Condition : PEAK_74 3m 91200_1522 HORIZONTAL Detector : Peak Project : 901542-02</p>
Avg.	<p>Site : 03CH16-HY Condition : AVG_BE_54 3m 91200_1522 HORIZONTAL Detector : Peak Project : 901542-02</p>	<p>Site : 03CH16-HY Condition : AVG_54 3m 91200_1522 HORIZONTAL Detector : Peak Project : 901542-02</p>



WIFI	2.4GHz 2400~2483.5MHz Band Edge @ 3m	
ANT	802.11g CH01 2412MHz	
1+2	Vertical	Fundamental
<p>Peak</p>	<p>Site : 03CH16-HY Condition : PEAK_8E_74 3m 91200_1522 VERTICAL RBW:1000.000KHz VBW:3000.000KHz SWT:Auto Detector : Peak Project : 901542-02</p>	<p>Site : 03CH16-HY Condition : PEAK_74 3m 91200_1522 VERTICAL RBW:1000.000KHz VBW:3000.000KHz SWT:Auto Detector : Peak Project : 901542-02</p>
<p>Avg.</p>	<p>Site : 03CH16-HY Condition : AVG_8E_54 3m 91200_1522 VERTICAL RBW:1000.000KHz VBW:0.010KHz SWT:Auto Detector : Peak Project : 901542-02</p>	<p>Site : 03CH16-HY Condition : AVG_54 3m 91200_1522 VERTICAL RBW:1000.000KHz VBW:0.010KHz SWT:Auto Detector : Peak Project : 901542-02</p>

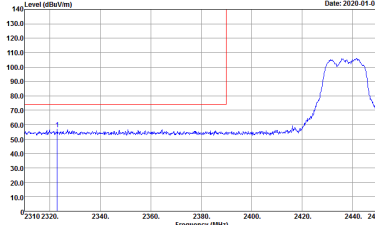
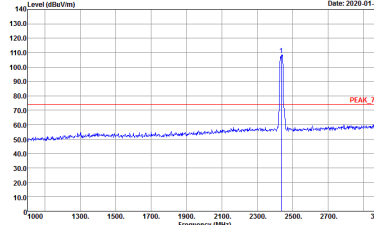
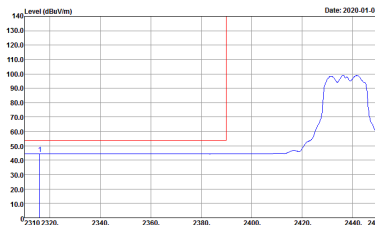
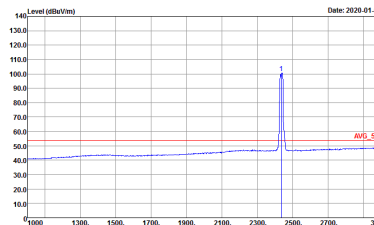

WIFI	2.4GHz 2400~2483.5MHz Band Edge @ 3m	
ANT	802.11g CH06 2437MHz - L	
1+2	Horizontal	Fundamental
Peak	 <p>Site : 03CH16-HY Condition : PEAK_BE_74 3m 91200_1522 HORIZONTAL RBW:1000.000kHz VBW:3000.000kHz SWT:Auto Detector : Peak Project : 901542-02</p>	 <p>Site : 03CH16-HY Condition : PEAK_74 3m 91200_1522 HORIZONTAL RBW:1000.000kHz VBW:3000.000kHz SWT:Auto Detector : Peak Project : 901542-02</p>
Avg.	 <p>Site : 03CH16-HY Condition : AVG_BE_54 3m 91200_1522 HORIZONTAL RBW:1000.000kHz VBW:0.010kHz SWT:Auto Detector : Peak Project : 901542-02</p>	 <p>Site : 03CH16-HY Condition : AVG_54 3m 91200_1522 HORIZONTAL RBW:1000.000kHz VBW:0.010kHz SWT:Auto Detector : Peak Project : 901542-02</p>

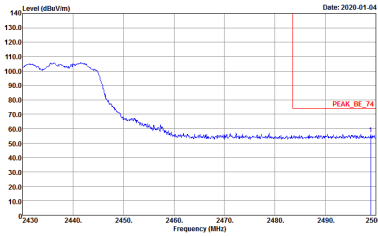
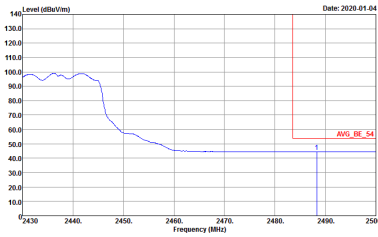

WIFI	2.4GHz 2400~2483.5MHz Band Edge @ 3m	
ANT	802.11g CH06 2437MHz - R	
1+2	Horizontal	Fundamental
<p>Peak</p>	 <p>Site : 03CH16-HY Condition : PEAK_BE_74 3m 91200_1522 HORIZONTAL RBW:1000.000kHz VBW:3000.000kHz SWF:Auto Detector : Peak Project : 901542-02</p>	<p>Left blank</p>
<p>Avg.</p>	 <p>Site : 03CH16-HY Condition : AVG_BE_54 3m 91200_1522 HORIZONTAL RBW:1000.000kHz VBW:0.010kHz SWF:Auto Detector : Peak Project : 901542-02</p>	<p>Left blank</p>

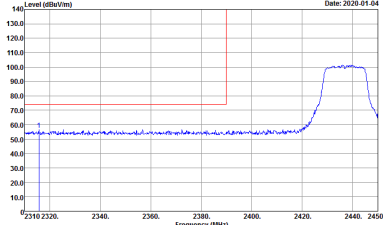
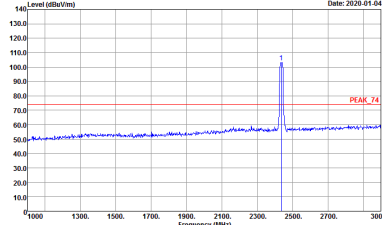
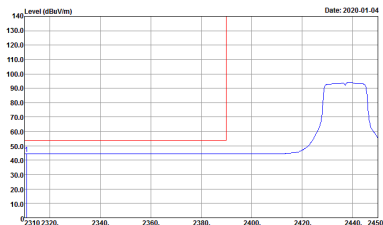
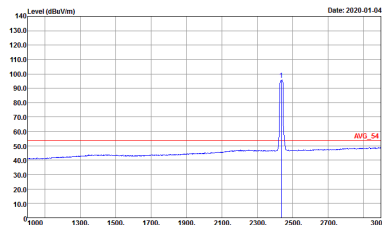

WIFI	2.4GHz 2400~2483.5MHz Band Edge @ 3m	
ANT	802.11g CH06 2437MHz - L	
1+2	Vertical	Fundamental
<p>Peak</p>	 <p>Site : 03CH16-HY Condition : PEAK_8E_74 3m 91200_1522 VERTICAL RBW:1000.000KHz VBW:3000.000KHz SWT:Auto Detector : Peak Project : 901542-02</p>	 <p>Site : 03CH16-HY Condition : PEAK_74 3m 91200_1522 VERTICAL RBW:1000.000KHz VBW:3000.000KHz SWT:Auto Detector : Peak Project : 901542-02</p>
<p>Avg.</p>	 <p>Site : 03CH16-HY Condition : AVG_8E_54 3m 91200_1522 VERTICAL RBW:1000.000KHz VBW:0.010KHz SWT:Auto Detector : Peak Project : 901542-02</p>	 <p>Site : 03CH16-HY Condition : AVG_54 3m 91200_1522 VERTICAL RBW:1000.000KHz VBW:0.010KHz SWT:Auto Detector : Peak Project : 901542-02</p>

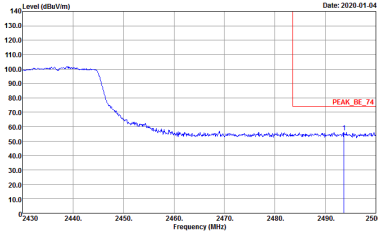
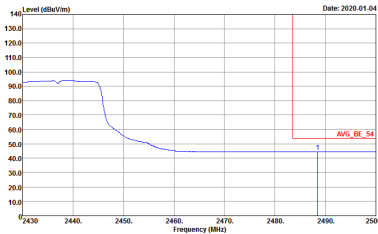

WIFI	2.4GHz 2400~2483.5MHz Band Edge @ 3m	
ANT	802.11g CH06 2437MHz - R	
1+2	Vertical	Fundamental
<p>Peak</p>	 <p>Site : 03CH16-HY Condition : PEAK_BE_74 3m 91200_1522 VERTICAL RBW:1000.000kHz VBW:3000.000kHz SWF:Auto Detector : Peak Project : 901542-02</p>	<p>Left Blank</p>
<p>Avg.</p>	 <p>Site : 03CH16-HY Condition : AVG_BE_54 3m 91200_1522 VERTICAL RBW:1000.000kHz VBW:0.010kHz SWF:Auto Detector : Peak Project : 901542-02</p>	<p>Left Blank</p>

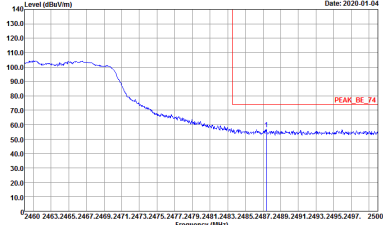
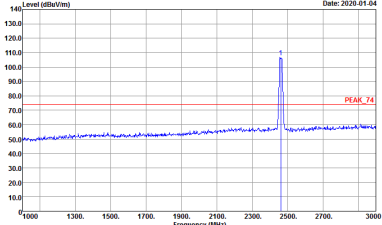
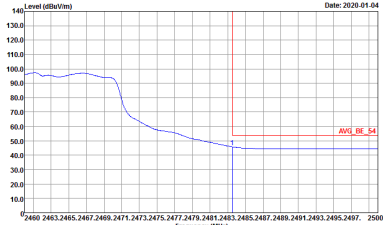
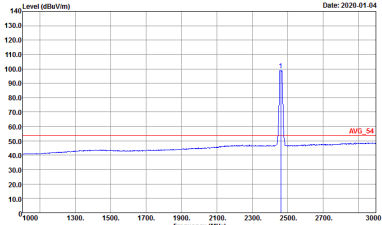

WIFI	2.4GHz 2400~2483.5MHz Band Edge @ 3m	
ANT	802.11g CH11 2462MHz	
1+2	Horizontal	Fundamental
<p>Peak</p>	 <p>Site : 03CH16-HY Condition : PEAK_BE_74 3m 91200_1522 HORIZONTAL RBW:1000.000KHz VBW:3000.000KHz SWT:Auto Detector : Peak Project : 901542-02</p>	 <p>Site : 03CH16-HY Condition : PEAK_74 3m 91200_1522 HORIZONTAL RBW:1000.000KHz VBW:3000.000KHz SWT:Auto Detector : Peak Project : 901542-02</p>
<p>Avg.</p>	 <p>Site : 03CH16-HY Condition : AVG_BE_54 3m 91200_1522 HORIZONTAL RBW:1000.000KHz VBW:0.010KHz SWT:Auto Detector : Peak Project : 901542-02</p>	 <p>Site : 03CH16-HY Condition : AVG_54 3m 91200_1522 HORIZONTAL RBW:1000.000KHz VBW:0.010KHz SWT:Auto Detector : Peak Project : 901542-02</p>

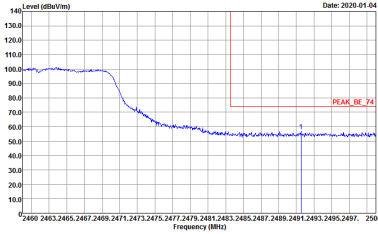
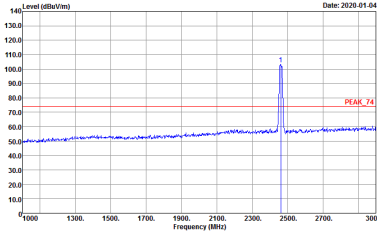
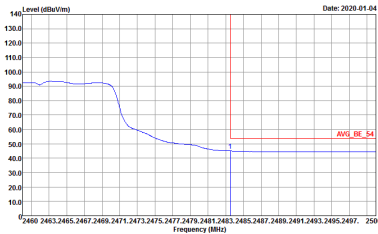
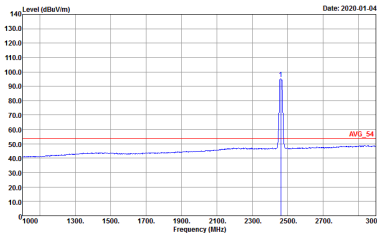

WIFI	2.4GHz 2400~2483.5MHz Band Edge @ 3m	
ANT	802.11g CH11 2462MHz	
1+2	Vertical	Fundamental
<p>Peak</p>	 <p>Site : 03CH16-11Y Condition : PEAK_BE_74 3m 91200_1522 VERTICAL RBW:1000.000KHz VBW:3000.000KHz SWT:Auto Detector : Peak Project : 901542-02</p>	 <p>Site : 03CH16-11Y Condition : PEAK_74 3m 91200_1522 VERTICAL RBW:1000.000KHz VBW:3000.000KHz SWT:Auto Detector : Peak Project : 901542-02</p>
<p>Avg.</p>	 <p>Site : 03CH16-11Y Condition : AVG_BE_54 3m 91200_1522 VERTICAL RBW:1000.000KHz VBW:0.010KHz SWT:Auto Detector : Peak Project : 901542-02</p>	 <p>Site : 03CH16-11Y Condition : AVG_54 3m 91200_1522 VERTICAL RBW:1000.000KHz VBW:0.010KHz SWT:Auto Detector : Peak Project : 901542-02</p>



2.4GHz 2400~2483.5MHz
 WIFI 802.11n HT20 (Band Edge @ 3m)

WIFI	2.4GHz 2400~2483.5MHz Band Edge @ 3m	
ANT	802.11n HT20 CH01 2412MHz	
1+2	Horizontal	Fundamental
Peak	<p>Site : 03CH16-HY Condition : PEAK_BE_74 3m 91200_1522 HORIZONTAL RBW:1000.000KHz VBW:3000.000KHz SWT:Auto Detector : Peak Project : 901542-02</p>	<p>Site : 03CH16-HY Condition : PEAK_74 3m 91200_1522 HORIZONTAL RBW:1000.000KHz VBW:3000.000KHz SWT:Auto Detector : Peak Project : 901542-02</p>
Avg.	<p>Site : 03CH16-HY Condition : AVG_BE_54 3m 91200_1522 HORIZONTAL RBW:1000.000KHz VBW:3000.000KHz SWT:Auto Detector : Peak Project : 901542-02</p>	<p>Site : 03CH16-HY Condition : AVG_54 3m 91200_1522 HORIZONTAL RBW:1000.000KHz VBW:3000.000KHz SWT:Auto Detector : Peak Project : 901542-02</p>



WIFI	2.4GHz 2400~2483.5MHz Band Edge @ 3m	
ANT	802.11n HT20 CH01 2412MHz	
1+2	Vertical	Fundamental
<p>Peak</p>	<p>Site : 03CH16-1HY Condition : PEAK_8E_74 3m 91200_1522 VERTICAL RBW:1000.000KHz VBW:3000.000KHz SWT:Auto Detector : Peak Project : 901542-02</p>	<p>Site : 03CH16-1HY Condition : PEAK_74 3m 91200_1522 VERTICAL RBW:1000.000KHz VBW:3000.000KHz SWT:Auto Detector : Peak Project : 901542-02</p>
<p>Avg.</p>	<p>Site : 03CH16-1HY Condition : AVG_8E_54 3m 91200_1522 VERTICAL RBW:1000.000KHz VBW:0.010KHz SWT:Auto Detector : Peak Project : 901542-02</p>	<p>Site : 03CH16-1HY Condition : AVG_54 3m 91200_1522 VERTICAL RBW:1000.000KHz VBW:0.010KHz SWT:Auto Detector : Peak Project : 901542-02</p>

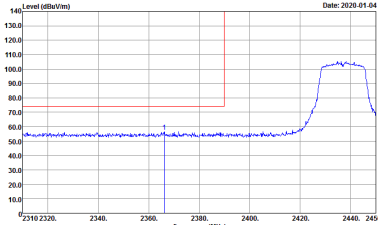
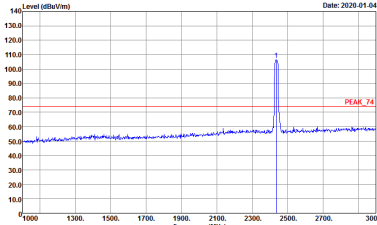
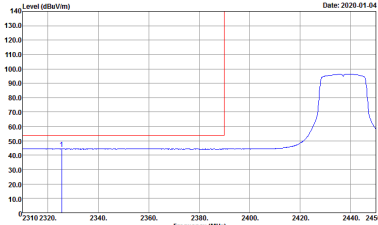
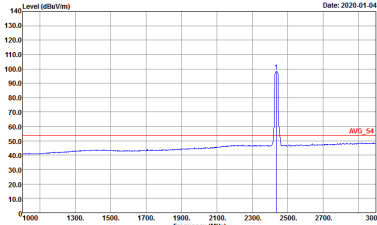

WIFI	2.4GHz 2400~2483.5MHz Band Edge @ 3m	
ANT	802.11n HT20 CH06 2437MHz - L	
1+2	Horizontal	Fundamental
Peak	 <p>Date: 2020-01-04</p> <p>Site : 03CH16-HY Condition : PEAK_BE_74 3m 91200_1522 HORIZONTAL RBW:1000.000KHz VBW:3000.000KHz SWT:Auto Detector : Peak Project : 901542-02</p>	 <p>Date: 2020-01-04</p> <p>Site : 03CH16-HY Condition : PEAK_74 3m 91200_1522 HORIZONTAL RBW:1000.000KHz VBW:3000.000KHz SWT:Auto Detector : Peak Project : 901542-02</p>
Avg.	 <p>Date: 2020-01-04</p> <p>Site : 03CH16-HY Condition : AVG_BE_54 3m 91200_1522 HORIZONTAL RBW:1000.000KHz VBW:0.010KHz SWT:Auto Detector : Peak Project : 901542-02</p>	 <p>Date: 2020-01-04</p> <p>Site : 03CH16-HY Condition : AVG_54 3m 91200_1522 HORIZONTAL RBW:1000.000KHz VBW:0.010KHz SWT:Auto Detector : Peak Project : 901542-02</p>

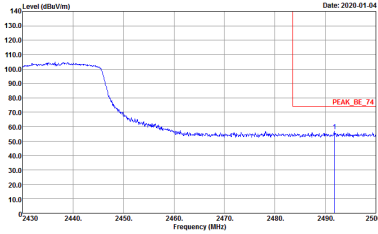
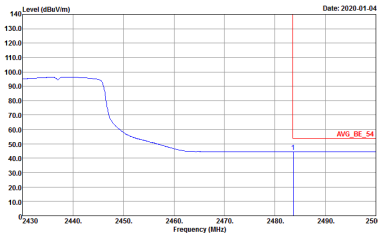

WIFI	2.4GHz 2400~2483.5MHz Band Edge @ 3m	
ANT	802.11n HT20 CH06 2437MHz - R	
1+2	Horizontal	Fundamental
<p>Peak</p>	 <p>Site : 03CH16-HY Condition : PEAK_BE_74 3m 91200_1522 HORIZONTAL RBW:1000.000kHz VBW:3000.000kHz SWF:Auto Detector : Peak Project : 901542-02</p>	<p>Left blank</p>
<p>Avg.</p>	 <p>Site : 03CH16-HY Condition : AVG_BE_54 3m 91200_1522 HORIZONTAL RBW:1000.000kHz VBW:0.010kHz SWF:Auto Detector : Peak Project : 901542-02</p>	<p>Left blank</p>

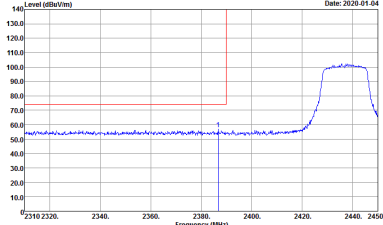
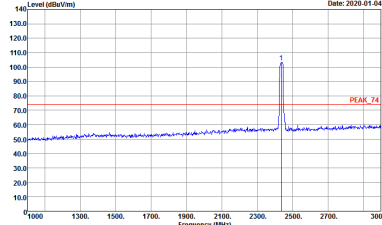
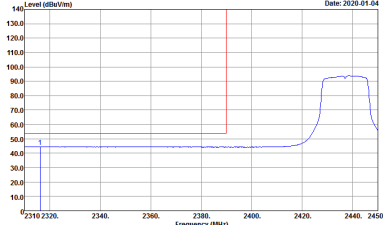
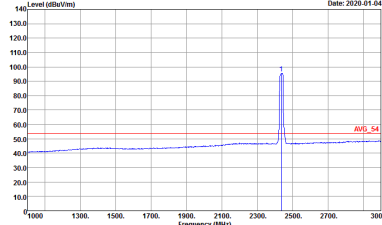

WIFI	2.4GHz 2400~2483.5MHz Band Edge @ 3m	
ANT	802.11n HT20 CH06 2437MHz - L	
1+2	Vertical	Fundamental
Peak	 <p>Date: 2020-01-04</p> <p>Site : 03CH16-HY Condition : PEAK_BE_74 3m 91200_1522 VERTICAL RBW:1000.000KHz VBW:3000.000KHz SWT:Auto Detector : Peak Project : 901542-02</p>	 <p>Date: 2020-01-04</p> <p>Site : 03CH16-HY Condition : PEAK_74 3m 91200_1522 VERTICAL RBW:1000.000KHz VBW:3000.000KHz SWT:Auto Detector : Peak Project : 901542-02</p>
Avg.	 <p>Date: 2020-01-04</p> <p>Site : 03CH16-HY Condition : AVG_BE_54 3m 91200_1522 VERTICAL RBW:1000.000KHz VBW:0.010KHz SWT:Auto Detector : Peak Project : 901542-02</p>	 <p>Date: 2020-01-04</p> <p>Site : 03CH16-HY Condition : AVG_54 3m 91200_1522 VERTICAL RBW:1000.000KHz VBW:0.010KHz SWT:Auto Detector : Peak Project : 901542-02</p>

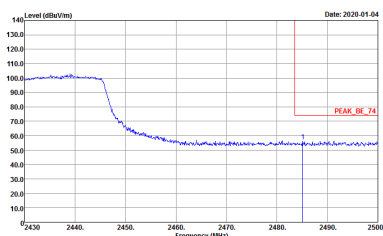
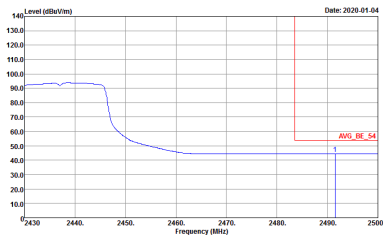

WIFI	2.4GHz 2400~2483.5MHz Band Edge @ 3m	
ANT	802.11n HT20 CH06 2437MHz - R	
1+2	Vertical	Fundamental
<p>Peak</p>	 <p>Site : 03CH16-HY Condition : PEAK_BE_74 3m 91200_1522 VERTICAL RBW:1000.000kHz VBW:3000.000kHz SWF:Auto Detector : Peak Project : 901542-02</p>	<p>Left Blank</p>
<p>Avg.</p>	 <p>Site : 03CH16-HY Condition : AVG_BE_54 3m 91200_1522 VERTICAL RBW:1000.000kHz VBW:0.010kHz SWF:Auto Detector : Peak Project : 901542-02</p>	<p>Left Blank</p>

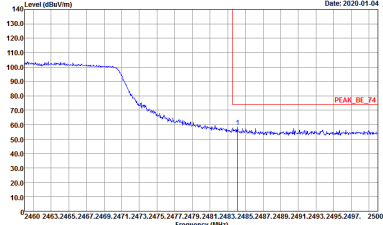
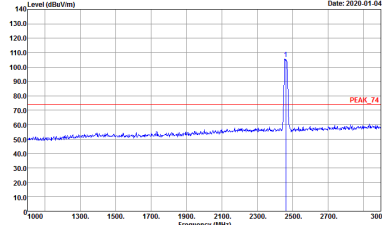
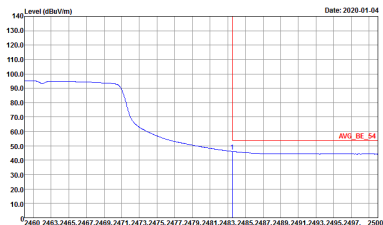
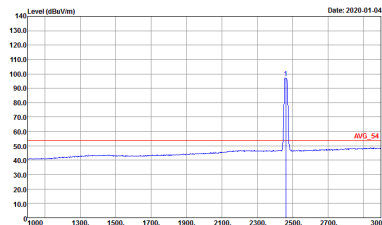

WIFI	2.4GHz 2400~2483.5MHz Band Edge @ 3m	
ANT	802.11n HT20 CH11 2462MHz	
1+2	Horizontal	Fundamental
<p>Peak</p>	 <p>Site : 03CH16-HY Condition : PEAK_BE_74 3m 91200_1522 HORIZONTAL RBW:1000.000KHz VBW:3000.000KHz SWT:Auto Detector : Peak Project : 901542-02</p>	 <p>Site : 03CH16-HY Condition : PEAK_74 3m 91200_1522 HORIZONTAL RBW:1000.000KHz VBW:3000.000KHz SWT:Auto Detector : Peak Project : 901542-02</p>
<p>Avg.</p>	 <p>Site : 03CH16-HY Condition : AVG_BE_54 3m 91200_1522 HORIZONTAL RBW:1000.000KHz VBW:0.010KHz SWT:Auto Detector : Peak Project : 901542-02</p>	 <p>Site : 03CH16-HY Condition : AVG_54 3m 91200_1522 HORIZONTAL RBW:1000.000KHz VBW:0.010KHz SWT:Auto Detector : Peak Project : 901542-02</p>

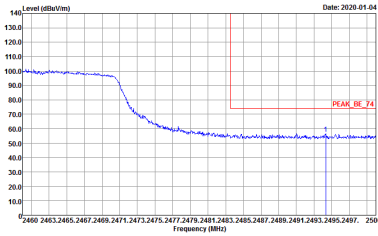
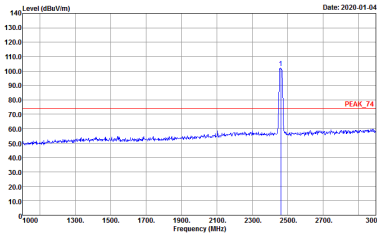
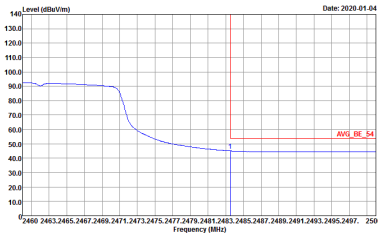
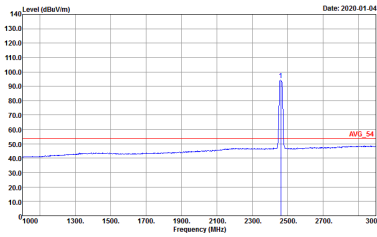

WIFI	2.4GHz 2400~2483.5MHz Fundamental @ 3m	
ANT	802.11n HT20 CH11 2462MHz	
1+2	Vertical	Fundamental
<p>Peak</p>	 <p>Site : 03CH16-11Y Condition : PEAK_BE_74 3m 91200_1522 VERTICAL RBW:1000.000KHz VBW:3000.000KHz SWT:Auto Detector : Peak Project : 901542-02</p>	 <p>Site : 03CH16-11Y Condition : PEAK_74 3m 91200_1522 VERTICAL RBW:1000.000KHz VBW:3000.000KHz SWT:Auto Detector : Peak Project : 901542-02</p>
<p>Avg.</p>	 <p>Site : 03CH16-11Y Condition : AVG_BE_54 3m 91200_1522 VERTICAL RBW:1000.000KHz VBW:0.010KHz SWT:Auto Detector : Peak Project : 901542-02</p>	 <p>Site : 03CH16-11Y Condition : AVG_54 3m 91200_1522 VERTICAL RBW:1000.000KHz VBW:0.010KHz SWT:Auto Detector : Peak Project : 901542-02</p>



2.4GHz 2400~2483.5MHz
WIFI 802.11b (Harmonic @ 3m)

Table with 2 columns: Horizontal and Vertical. Rows include WIFI (2.4GHz 2400~2483.5MHz Harmonic @ 3m), ANT (802.11b CH01 2412MHz), and 1+2 (Peak and Avg. plots for both orientations). Each plot shows Level (dBuV/m) vs Frequency (MHz) with a peak at 2412MHz.