

APPENDIX J: LTE DOWNLINK ONLY CARRIER AGGREGATION TEST REDUCTION METHODOLOGY

SAR test exclusion for LTE downlink Carrier Aggregation is determined by power measurements according to the number of component carriers (CCs) supported by the product implementation. Per April 2018 TCBC Workshop Notes, the following test reduction methodology was applied to determine the combinations required for conducted power measurements.

LTE DLCA Test Reduction Methodology:

- The supported combinations were arranged by the number of component carriers in columns.
- Any limitations on the PCC or SCC for each combination were identified alongside the combination (e.g. CA_2A-2A-4A-12A, but B12 can only be configured as a SCC).
- Power measurements were performed for "supersets" (LTE CA combinations with multiple components carriers) and any "subsets" (LTE CA combinations with fewer component carriers) that were not completely covered by the supersets.
- Only subsets that have the exact same components as a superset were excluded for measurement.
- When there were certain restrictions on component carriers that existed in the superset that were not applied for the subset, the subset configuration was additionally evaluated.
- Both inter-band and intra-band downlink carrier aggregation scenarios were considered.
- Downlink CA combinations for SISO and 4x4 Downlink MIMO operations were measured independently, per May 2017 TCBC Workshop notes.

Table J-1 – Example of Exclusion Table for SISO Configurations

Index	BCC	Supported Channel Bandwidth (MHz)				Restriction	Completely Covered by Measurement Superset
		CC1	CC2	CC3	CC4		
CCC#1	CA_12A	5, 10, 15, 20	5, 10, 15, 20	5, 10, 15, 20	5, 10, 15, 20	No	
CCC#2	CA_2A	5, 10, 15, 20	5, 10, 15, 20	5, 10, 15, 20	5, 10, 15, 20	No	
CCC#3	CA_2A-2A	5, 10, 15, 20	5, 10, 15, 20	5, 10, 15, 20	5, 10, 15, 20	No	
CCC#4	CA_2A-4A	5, 10, 15, 20	5, 10, 15, 20	5, 10, 15, 20	5, 10, 15, 20	No	
CCC#5	CA_2A-6A	5, 10, 15, 20	5, 10, 15, 20	5, 10, 15, 20	5, 10, 15, 20	No	
CCC#6	CA_2A-8A	5, 10, 15, 20	5, 10, 15, 20	5, 10, 15, 20	5, 10, 15, 20	No	
CCC#7	CA_2A-10A	5, 10, 15, 20	5, 10, 15, 20	5, 10, 15, 20	5, 10, 15, 20	No	
CCC#8	CA_2A-12A	5, 10, 15, 20	5, 10, 15, 20	5, 10, 15, 20	5, 10, 15, 20	No	
CCC#9	CA_2A-14A	5, 10, 15, 20	5, 10, 15, 20	5, 10, 15, 20	5, 10, 15, 20	No	
CCC#10	CA_2A-16A	5, 10, 15, 20	5, 10, 15, 20	5, 10, 15, 20	5, 10, 15, 20	No	
CCC#11	CA_2A-18A	5, 10, 15, 20	5, 10, 15, 20	5, 10, 15, 20	5, 10, 15, 20	No	
CCC#12	CA_2A-20A	5, 10, 15, 20	5, 10, 15, 20	5, 10, 15, 20	5, 10, 15, 20	No	
CCC#13	CA_2A-22A	5, 10, 15, 20	5, 10, 15, 20	5, 10, 15, 20	5, 10, 15, 20	No	
CCC#14	CA_2A-24A	5, 10, 15, 20	5, 10, 15, 20	5, 10, 15, 20	5, 10, 15, 20	No	
CCC#15	CA_2A-26A	5, 10, 15, 20	5, 10, 15, 20	5, 10, 15, 20	5, 10, 15, 20	No	
CCC#16	CA_2A-28A	5, 10, 15, 20	5, 10, 15, 20	5, 10, 15, 20	5, 10, 15, 20	No	
CCC#17	CA_2A-30A	5, 10, 15, 20	5, 10, 15, 20	5, 10, 15, 20	5, 10, 15, 20	No	
CCC#18	CA_2A-32A	5, 10, 15, 20	5, 10, 15, 20	5, 10, 15, 20	5, 10, 15, 20	No	
CCC#19	CA_2A-34A	5, 10, 15, 20	5, 10, 15, 20	5, 10, 15, 20	5, 10, 15, 20	No	
CCC#20	CA_2A-36A	5, 10, 15, 20	5, 10, 15, 20	5, 10, 15, 20	5, 10, 15, 20	No	
CCC#21	CA_2A-38A	5, 10, 15, 20	5, 10, 15, 20	5, 10, 15, 20	5, 10, 15, 20	No	
CCC#22	CA_2A-40A	5, 10, 15, 20	5, 10, 15, 20	5, 10, 15, 20	5, 10, 15, 20	No	
CCC#23	CA_2A-42A	5, 10, 15, 20	5, 10, 15, 20	5, 10, 15, 20	5, 10, 15, 20	No	
CCC#24	CA_2A-44A	5, 10, 15, 20	5, 10, 15, 20	5, 10, 15, 20	5, 10, 15, 20	No	
CCC#25	CA_2A-46A	5, 10, 15, 20	5, 10, 15, 20	5, 10, 15, 20	5, 10, 15, 20	No	
CCC#26	CA_2A-48A	5, 10, 15, 20	5, 10, 15, 20	5, 10, 15, 20	5, 10, 15, 20	No	
CCC#27	CA_2A-50A	5, 10, 15, 20	5, 10, 15, 20	5, 10, 15, 20	5, 10, 15, 20	No	
CCC#28	CA_2A-52A	5, 10, 15, 20	5, 10, 15, 20	5, 10, 15, 20	5, 10, 15, 20	No	
CCC#29	CA_2A-54A	5, 10, 15, 20	5, 10, 15, 20	5, 10, 15, 20	5, 10, 15, 20	No	
CCC#30	CA_2A-56A	5, 10, 15, 20	5, 10, 15, 20	5, 10, 15, 20	5, 10, 15, 20	No	
CCC#31	CA_2A-58A	5, 10, 15, 20	5, 10, 15, 20	5, 10, 15, 20	5, 10, 15, 20	No	
CCC#32	CA_2A-60A	5, 10, 15, 20	5, 10, 15, 20	5, 10, 15, 20	5, 10, 15, 20	No	
CCC#33	CA_2A-62A	5, 10, 15, 20	5, 10, 15, 20	5, 10, 15, 20	5, 10, 15, 20	No	
CCC#34	CA_2A-64A	5, 10, 15, 20	5, 10, 15, 20	5, 10, 15, 20	5, 10, 15, 20	No	
CCC#35	CA_2A-66A	5, 10, 15, 20	5, 10, 15, 20	5, 10, 15, 20	5, 10, 15, 20	No	
CCC#36	CA_2A-68A	5, 10, 15, 20	5, 10, 15, 20	5, 10, 15, 20	5, 10, 15, 20	No	
CCC#37	CA_2A-70A	5, 10, 15, 20	5, 10, 15, 20	5, 10, 15, 20	5, 10, 15, 20	No	
CCC#38	CA_2A-72A	5, 10, 15, 20	5, 10, 15, 20	5, 10, 15, 20	5, 10, 15, 20	No	
CCC#39	CA_2A-74A	5, 10, 15, 20	5, 10, 15, 20	5, 10, 15, 20	5, 10, 15, 20	No	
CCC#40	CA_2A-76A	5, 10, 15, 20	5, 10, 15, 20	5, 10, 15, 20	5, 10, 15, 20	No	
CCC#41	CA_2A-78A	5, 10, 15, 20	5, 10, 15, 20	5, 10, 15, 20	5, 10, 15, 20	No	
CCC#42	CA_2A-80A	5, 10, 15, 20	5, 10, 15, 20	5, 10, 15, 20	5, 10, 15, 20	No	
CCC#43	CA_2A-82A	5, 10, 15, 20	5, 10, 15, 20	5, 10, 15, 20	5, 10, 15, 20	No	
CCC#44	CA_2A-84A	5, 10, 15, 20	5, 10, 15, 20	5, 10, 15, 20	5, 10, 15, 20	No	
CCC#45	CA_2A-86A	5, 10, 15, 20	5, 10, 15, 20	5, 10, 15, 20	5, 10, 15, 20	No	
CCC#46	CA_2A-88A	5, 10, 15, 20	5, 10, 15, 20	5, 10, 15, 20	5, 10, 15, 20	No	
CCC#47	CA_2A-90A	5, 10, 15, 20	5, 10, 15, 20	5, 10, 15, 20	5, 10, 15, 20	No	
CCC#48	CA_2A-92A	5, 10, 15, 20	5, 10, 15, 20	5, 10, 15, 20	5, 10, 15, 20	No	
CCC#49	CA_2A-94A	5, 10, 15, 20	5, 10, 15, 20	5, 10, 15, 20	5, 10, 15, 20	No	
CCC#50	CA_2A-96A	5, 10, 15, 20	5, 10, 15, 20	5, 10, 15, 20	5, 10, 15, 20	No	
CCC#51	CA_2A-98A	5, 10, 15, 20	5, 10, 15, 20	5, 10, 15, 20	5, 10, 15, 20	No	
CCC#52	CA_2A-100A	5, 10, 15, 20	5, 10, 15, 20	5, 10, 15, 20	5, 10, 15, 20	No	
CCC#53	CA_2A-102A	5, 10, 15, 20	5, 10, 15, 20	5, 10, 15, 20	5, 10, 15, 20	No	
CCC#54	CA_2A-104A	5, 10, 15, 20	5, 10, 15, 20	5, 10, 15, 20	5, 10, 15, 20	No	
CCC#55	CA_2A-106A	5, 10, 15, 20	5, 10, 15, 20	5, 10, 15, 20	5, 10, 15, 20	No	
CCC#56	CA_2A-108A	5, 10, 15, 20	5, 10, 15, 20	5, 10, 15, 20	5, 10, 15, 20	No	
CCC#57	CA_2A-110A	5, 10, 15, 20	5, 10, 15, 20	5, 10, 15, 20	5, 10, 15, 20	No	
CCC#58	CA_2A-112A	5, 10, 15, 20	5, 10, 15, 20	5, 10, 15, 20	5, 10, 15, 20	No	
CCC#59	CA_2A-114A	5, 10, 15, 20	5, 10, 15, 20	5, 10, 15, 20	5, 10, 15, 20	No	
CCC#60	CA_2A-116A	5, 10, 15, 20	5, 10, 15, 20	5, 10, 15, 20	5, 10, 15, 20	No	
CCC#61	CA_2A-118A	5, 10, 15, 20	5, 10, 15, 20	5, 10, 15, 20	5, 10, 15, 20	No	
CCC#62	CA_2A-120A	5, 10, 15, 20	5, 10, 15, 20	5, 10, 15, 20	5, 10, 15, 20	No	
CCC#63	CA_2A-122A	5, 10, 15, 20	5, 10, 15, 20	5, 10, 15, 20	5, 10, 15, 20	No	
CCC#64	CA_2A-124A	5, 10, 15, 20	5, 10, 15, 20	5, 10, 15, 20	5, 10, 15, 20	No	
CCC#65	CA_2A-126A	5, 10, 15, 20	5, 10, 15, 20	5, 10, 15, 20	5, 10, 15, 20	No	
CCC#66	CA_2A-128A	5, 10, 15, 20	5, 10, 15, 20	5, 10, 15, 20	5, 10, 15, 20	No	
CCC#67	CA_2A-130A	5, 10, 15, 20	5, 10, 15, 20	5, 10, 15, 20	5, 10, 15, 20	No	
CCC#68	CA_2A-132A	5, 10, 15, 20	5, 10, 15, 20	5, 10, 15, 20	5, 10, 15, 20	No	
CCC#69	CA_2A-134A	5, 10, 15, 20	5, 10, 15, 20	5, 10, 15, 20	5, 10, 15, 20	No	
CCC#70	CA_2A-136A	5, 10, 15, 20	5, 10, 15, 20	5, 10, 15, 20	5, 10, 15, 20	No	
CCC#71	CA_2A-138A	5, 10, 15, 20	5, 10, 15, 20	5, 10, 15, 20	5, 10, 15, 20	No	
CCC#72	CA_2A-140A	5, 10, 15, 20	5, 10, 15, 20	5, 10, 15, 20	5, 10, 15, 20	No	
CCC#73	CA_2A-142A	5, 10, 15, 20	5, 10, 15, 20	5, 10, 15, 20	5, 10, 15, 20	No	
CCC#74	CA_2A-144A	5, 10, 15, 20	5, 10, 15, 20	5, 10, 15, 20	5, 10, 15, 20	No	
CCC#75	CA_2A-146A	5, 10, 15, 20	5, 10, 15, 20	5, 10, 15, 20	5, 10, 15, 20	No	
CCC#76	CA_2A-148A	5, 10, 15, 20	5, 10, 15, 20	5, 10, 15, 20	5, 10, 15, 20	No	
CCC#77	CA_2A-150A	5, 10, 15, 20	5, 10, 15, 20	5, 10, 15, 20	5, 10, 15, 20	No	
CCC#78	CA_2A-152A	5, 10, 15, 20	5, 10, 15, 20	5, 10, 15, 20	5, 10, 15, 20	No	
CCC#79	CA_2A-154A	5, 10, 15, 20	5, 10, 15, 20	5, 10, 15, 20	5, 10, 15, 20	No	
CCC#80	CA_2A-156A	5, 10, 15, 20	5, 10, 15, 20	5, 10, 15, 20	5, 10, 15, 20	No	
CCC#81	CA_2A-158A	5, 10, 15, 20	5, 10, 15, 20	5, 10, 15, 20	5, 10, 15, 20	No	
CCC#82	CA_2A-160A	5, 10, 15, 20	5, 10, 15, 20	5, 10, 15, 20	5, 10, 15, 20	No	
CCC#83	CA_2A-162A	5, 10, 15, 20	5, 10, 15, 20	5, 10, 15, 20	5, 10, 15, 20	No	
CCC#84	CA_2A-164A	5, 10, 15, 20	5, 10, 15, 20	5, 10, 15, 20	5, 10, 15, 20	No	
CCC#85	CA_2A-166A	5, 10, 15, 20	5, 10, 15, 20	5, 10, 15, 20	5, 10, 15, 20	No	
CCC#86	CA_2A-168A	5, 10, 15, 20	5, 10, 15, 20	5, 10, 15, 20	5, 10, 15, 20	No	
CCC#87	CA_2A-170A	5, 10, 15, 20	5, 10, 15, 20	5, 10, 15, 20	5, 10, 15, 20	No	
CCC#88	CA_2A-172A	5, 10, 15, 20	5, 10, 15, 20	5, 10, 15, 20	5, 10, 15, 20	No	
CCC#89	CA_2A-174A	5, 10, 15, 20	5, 10, 15, 20	5, 10, 15, 20	5, 10, 15, 20	No	
CCC#90	CA_2A-176A	5, 10, 15, 20	5, 10, 15, 20	5, 10, 15, 20	5, 10, 15, 20	No	
CCC#91	CA_2A-178A	5, 10, 15, 20	5, 10, 15, 20	5, 10, 15, 20	5, 10, 15, 20	No	
CCC#92	CA_2A-180A	5, 10, 15, 20	5, 10, 15, 20	5, 10, 15, 20	5, 10, 15, 20	No	
CCC#93	CA_2A-182A	5, 10, 15, 20	5, 10, 15, 20	5, 10, 15, 20	5, 10, 15, 20	No	
CCC#94	CA_2A-184A	5, 10, 15, 20	5, 10, 15, 20	5, 10, 15, 20	5, 10, 15, 20	No	
CCC#95	CA_2A-186A	5, 10, 15, 20	5, 10, 15, 20	5, 10, 15, 20	5, 10, 15, 20	No	
CCC#96	CA_2A-188A	5, 10, 15, 20	5, 10, 15, 20	5, 10, 15, 20	5, 10, 15, 20	No	
CCC#97	CA_2A-190A	5, 10, 15, 20	5, 10, 15, 20	5, 10, 15, 20	5, 10, 15, 20	No	
CCC#98	CA_2A-192A	5, 10, 15, 20	5, 10, 15, 20	5, 10, 15, 20	5, 10, 15, 20	No	
CCC#99	CA_2A-194A	5, 10, 15, 20	5, 10, 15, 20	5, 10, 15, 20	5, 10, 15, 20	No	
CCC#100	CA_2A-196A	5, 10, 15, 20	5, 10, 15, 20	5, 10, 15, 20	5, 10, 15, 20	No	
CCC#101	CA_2A-198A	5, 10, 15, 20	5, 10, 15, 20	5, 10, 15, 20	5, 10, 15, 20	No	
CCC#102	CA_2A-200A	5, 10, 15, 20	5, 10, 15, 20	5, 10, 15, 20	5, 10, 15, 20	No	
CCC#103	CA_2A-202A	5, 10, 15, 20	5, 10, 15, 20	5, 10, 15, 20	5, 10, 15, 20	No	
CCC#104	CA_2A-204A	5, 10, 15, 20	5, 10, 15, 20	5, 10, 15, 20	5, 10, 15, 20	No	
CCC#105	CA_2A-206A	5, 10, 15, 20	5, 10, 15, 20	5, 10, 15, 20	5, 10, 15, 20	No	
CCC#106	CA_2A-208A	5, 10, 15, 20	5, 10, 15, 20	5, 10, 15, 20	5, 10, 15, 20	No	
CCC#107	CA_2A-210A	5, 10, 15, 20	5, 10, 15, 20	5, 10, 15, 20	5, 10, 15, 20	No	
CCC#108	CA_2A-212A	5, 10, 15, 20	5, 10, 15, 20	5, 10, 15, 20	5, 10, 15, 20	No	
CCC#109	CA_2A-214A	5, 10, 15, 20	5, 10, 15, 20	5, 10, 15, 20	5, 10, 15, 20	No	
CCC#110	CA_2A-216A	5, 10, 15, 20	5, 10, 15, 20	5, 10, 15, 20	5, 10, 15, 20	No	
CCC#111	CA_2A-218A	5, 10, 15, 20	5, 10, 15, 20	5, 10, 15, 20	5, 10, 15, 20	No	
CCC#112	CA_2A-220A	5, 10, 15, 20	5, 10, 15				

only) active are made in accordance to KDB Publication 941225 D05Av01r02. The RRC connection is only handled by one cell, the primary component carrier (PCC) for downlink and uplink communications. After making a data connection to the PCC, the UE device adds secondary component carrier(s) (SCC) on the downlink only. All uplink communications and acknowledgements remain identical to specifications when downlink carrier aggregation is inactive on the PCC. Additional conducted output powers are measured with the downlink carrier aggregation active for the configuration with highest measured maximum conducted power with downlink carrier aggregation active measured among the channel bandwidth, modulation, and RB combinations in each frequency band.

This device supports LAA with downlink carrier aggregation only. It uses carrier aggregation in the downlink to combine LTE in the unlicensed spectrum (i.e. LTE Band 46) with LTE in the licensed band (served as PCC). All uplink communications and acknowledgements on the PCC remain identical to specifications when downlink carrier aggregation is inactive.

Per FCC KDB Publication 941225 D05Av01r02, no SAR measurements are required for carrier aggregation configurations when the maximum average output power with downlink only carrier aggregation active is not more than 0.25 dB higher than the average output power with downlink only carrier aggregation inactive. All bands required for SAR testing per FCC KDB procedures were considered. Based on the measured maximum powers below, no additional SAR tests were required for DLCA SAR configurations.

General PCC and SCC configuration selection procedure

- PCC uplink channel, channel bandwidth, modulation and RB configurations were selected based on section C)3)b)ii) of KDB 941225 D05 V01r02. All LTE bandwidth conducted powers needed for PCC uplink configuration selection can be found in Section 9.3 and appendix I. The downlink PCC channel was paired with the selected PCC uplink channel according to normal configurations without carrier aggregation.
- To maximize aggregated bandwidth, highest channel bandwidth available for that CA combination was selected for SCC. For inter-band CA, the SCC downlink channels were selected near the middle of their transmission bands. For contiguous intra-band CA, the downlink channel spacing between the component carriers was set to multiple of 300 kHz less than the nominal channel spacing defined in section 5.4.1A of 3GPP TS 36.521. For non-contiguous intra-band CA, the downlink channel spacing between the component carriers was set to be larger than the nominal channel spacing and provided maximum separation between the component carriers.
- All selected PCC and SCC(s) remained fully within the uplink/downlink transmission band of the respective component carrier.

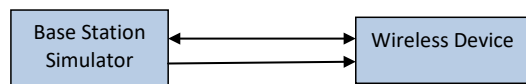

**Figure J-1
DL CA Power Measurement Setup**

FCC ID: PY7-76056F	SAR EVALUATION REPORT	Approved by: Technical Manager
DUT Type: Portable Handset		APPENDIX J: Page 2 of 10

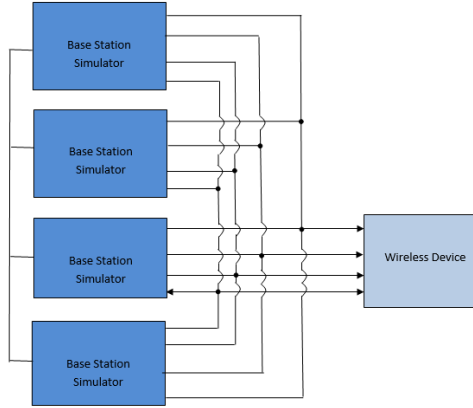

Figure J-2
DL CA with DL 4x4 MIMO Power Measurement Setup

J.2 Downlink Carrier Aggregation RF Conducted Powers

J.2.1 LTE Band 71 as PCC

Table J-3
Maximum Output Powers

Combination	PCC Band	PCC BW [MHz]	PCC (UL) Ch.	PCC				SCC 1				SCC 2				SCC 3				Power										
				PCC (UL) Freq. [MHz]	Mod.	PCC UL RB	PCC UL RB Offset	PCC (DL) Channel	PCC (DL) Freq. [MHz]	SCC Band	SCC BW [MHz]	SCC (DL) Channel	SCC (DL) Freq. [MHz]	SCC Band	SCC BW [MHz]	SCC (DL) Channel	SCC (DL) Freq. [MHz]	SCC Band	SCC BW [MHz]	SCC (DL) Channel	SCC (DL) Freq. [MHz]	LTE Tx Power with DL CA Enabled (dBm)	LTE Single Carrier Tx Power (dBm)							
CA 4A-4A-71A	LTE B71	5	133147	665.5	QPSK	1	12	68611	619.5	LTE B4	20	2175	2132.5	LTE B4	10	2300	2150	-	-	-	-	-	-	-	23.94	24.04				
CA 2A-2A-4A-71A	LTE B71	5	133147	665.5	QPSK	1	12	68611	619.5	LTE B2	20	900	1960	LTE B2	20	700	1940	LTE B4	20	2175	2132.5	2145	66786	2145	66786	2145	66786	2145	23.85	24.04
CA 2A-2A-66A-71A	LTE B71	5	133147	665.5	QPSK	1	12	68611	619.5	LTE B2	20	900	1960	LTE B2	20	700	1940	LTE B66	20	66786	2145	66786	2145	66786	2145	66786	2145	23.83	24.04	
CA 2A-66A-66A-71A	LTE B71	5	133147	665.5	QPSK	1	12	68611	619.5	LTE B2	20	900	1960	LTE B66	20	66786	2145	LTE B66	20	67236	2190	67236	2190	67236	2190	67236	2190	23.91	24.04	
CA 2A-66C-71A	LTE B71	5	133147	665.5	QPSK	1	12	68611	619.5	LTE B2	20	900	1960	LTE B66	20	66786	2145	LTE B66	20	66984	2164.8	66984	2164.8	66984	2164.8	66984	2164.8	23.90	24.04	

J.2.2 LTE Band 12 as PCC

Table J-4
Maximum Output Powers

Combination	PCC Band	PCC BW [MHz]	PCC (UL) Ch.	PCC				SCC 1				SCC 2				SCC 3				SCC 4				Power							
				PCC (UL) Freq. [MHz]	Mod.	PCC UL RB	PCC UL RB Offset	PCC (DL) Channel	PCC (DL) Freq. [MHz]	SCC Band	SCC BW [MHz]	SCC (DL) Channel	SCC (DL) Freq. [MHz]	SCC Band	SCC BW [MHz]	SCC (DL) Channel	SCC (DL) Freq. [MHz]	SCC Band	SCC BW [MHz]	SCC (DL) Channel	SCC (DL) Freq. [MHz]	SCC Band	SCC BW [MHz]	SCC (DL) Channel	SCC (DL) Freq. [MHz]	LTE Tx Power with DL CA Enabled (dBm)	LTE Single Carrier Tx Power (dBm)				
CA 12A-66A (1)	LTE B12	5	23095	707.5	QPSK	1	12	5095	737.5	LTE B66	20	66786	2145	-	-	-	-	-	-	-	-	-	-	-	-	-	-	-	24.06	23.91	
CA 12A-66A (2)	LTE B12	5	23095	707.5	QPSK	1	12	5095	737.5	LTE B66	20	66786	2145	-	-	-	-	-	-	-	-	-	-	-	-	-	-	-	24.06	23.91	
CA 2A-12A (1)	LTE B12	5	23095	707.5	QPSK	1	12	5095	737.5	LTE B2	20	900	1960	-	-	-	-	-	-	-	-	-	-	-	-	-	-	-	24.03	23.91	
CA 4A-12A (1)	LTE B12	5	23095	707.5	QPSK	1	12	5095	737.5	LTE B4	20	2175	2132.5	-	-	-	-	-	-	-	-	-	-	-	-	-	-	-	24.03	23.91	
CA 4A-12A (2)	LTE B12	5	23095	707.5	QPSK	1	12	5095	737.5	LTE B4	20	2175	2132.5	-	-	-	-	-	-	-	-	-	-	-	-	-	-	-	24.00	23.91	
CA 12A-66A	LTE B12	5	23095	707.5	QPSK	1	12	5095	737.5	LTE B12	5	5047	732.7	LTE B66	20	66786	2145	-	-	-	-	-	-	-	-	-	-	-	-	23.73	23.91
CA 2A-4A-12A	LTE B12	5	23095	707.5	QPSK	1	12	5095	737.5	LTE B2	20	900	1960	LTE B4	20	2175	2132.5	-	-	-	-	-	-	-	-	-	-	-	-	23.72	23.91
CA 4A-12B	LTE B12	5	23095	707.5	QPSK	1	12	5095	737.5	LTE B12	5	5047	732.7	LTE B4	20	2175	2132.5	-	-	-	-	-	-	-	-	-	-	-	-	23.70	23.91
CA 4A-12A-12A	LTE B12	5	23095	707.5	QPSK	1	12	5095	737.5	LTE B4	20	2175	2132.5	LTE B4	20	2250	2190	-	-	-	-	-	-	-	-	-	-	-	-	23.74	23.91
CA 2A-12A-66C	LTE B12	5	23095	707.5	QPSK	1	12	5095	737.5	LTE B2	20	900	1960	LTE B66	20	66786	2145	LTE B66	20	66984	2164.8	-	-	-	-	-	-	-	-	23.70	23.91
CA 2A-2A-12A-66A-66A	LTE B12	5	23095	707.5	QPSK	1	12	5095	737.5	LTE B2	20	900	1960	LTE B2	20	700	1940	LTE B66	20	66786	2145	LTE B66	20	67236	2190	67236	2190	67236	2190	23.75	23.91

J.2.3 LTE Band 13 as PCC

Table J-5
Maximum Output Powers

Combination	PCC Band	PCC BW [MHz]	PCC (UL) Ch.	PCC				SCC 1				SCC 2				SCC 3				Power										
				PCC (UL) Freq. [MHz]	Mod.	PCC UL RB	PCC UL RB Offset	PCC (DL) Channel	PCC (DL) Freq. [MHz]	SCC Band	SCC BW [MHz]	SCC (DL) Channel	SCC (DL) Freq. [MHz]	SCC Band	SCC BW [MHz]	SCC (DL) Channel	SCC (DL) Freq. [MHz]	SCC Band	SCC BW [MHz]	SCC (DL) Channel	SCC (DL) Freq. [MHz]	LTE Tx Power with DL CA Enabled (dBm)	LTE Single Carrier Tx Power (dBm)							
CA 13A-46A-46A	LTE B13	10	23230	782	QPSK	1	49	5230	751	LTE B46	20	50665	5537.5	LTE B46	20	47090	5180	-	-	-	-	-	-	-	-	-	-	-	23.93	24.09
CA 13A-46C-46A	LTE B13	10	23230	782	QPSK	1	49	5230	751	LTE B48	20	50665	5537.5	LTE B48	20	50467	5517.7	LTE B66	20	66786	2145	66786	2145	66786	2145	66786	2145	24.02	24.09	
CA 13A-46A-66B	LTE B13	10	23230	782	QPSK	1	49	5230	751	LTE B48	20	50665	5537.5	LTE B66	15	66786	2145	LTE B66	5	66978	2164.3	66978	2164.3	66978	2164.3	66978	2164.3	24.02	24.09	
CA 13A-48A-66C	LTE B13	10	23230	782	QPSK	1	49	5230	751	LTE B48	20	55990	3625	LTE B66	20	66786	2145	LTE B66	20	66984	2164.8	66984	2164.8	66984	2164.8	66984	2164.8	24.00	24.09	
CA 2A-13A-46C	LTE B13	10	23230	782	QPSK	1	49	5230	751	LTE B2	20	900	1960	LTE B46	20	50665	5537.5	LTE B46	20	50467	5517.7	-	-	-	-	-	-	-	23.94	24.09

FCC ID: PY7-76056F	SAR EVALUATION REPORT	Approved by: Technical Manager
DUT Type: Portable Handset		APPENDIX J: Page 3 of 10

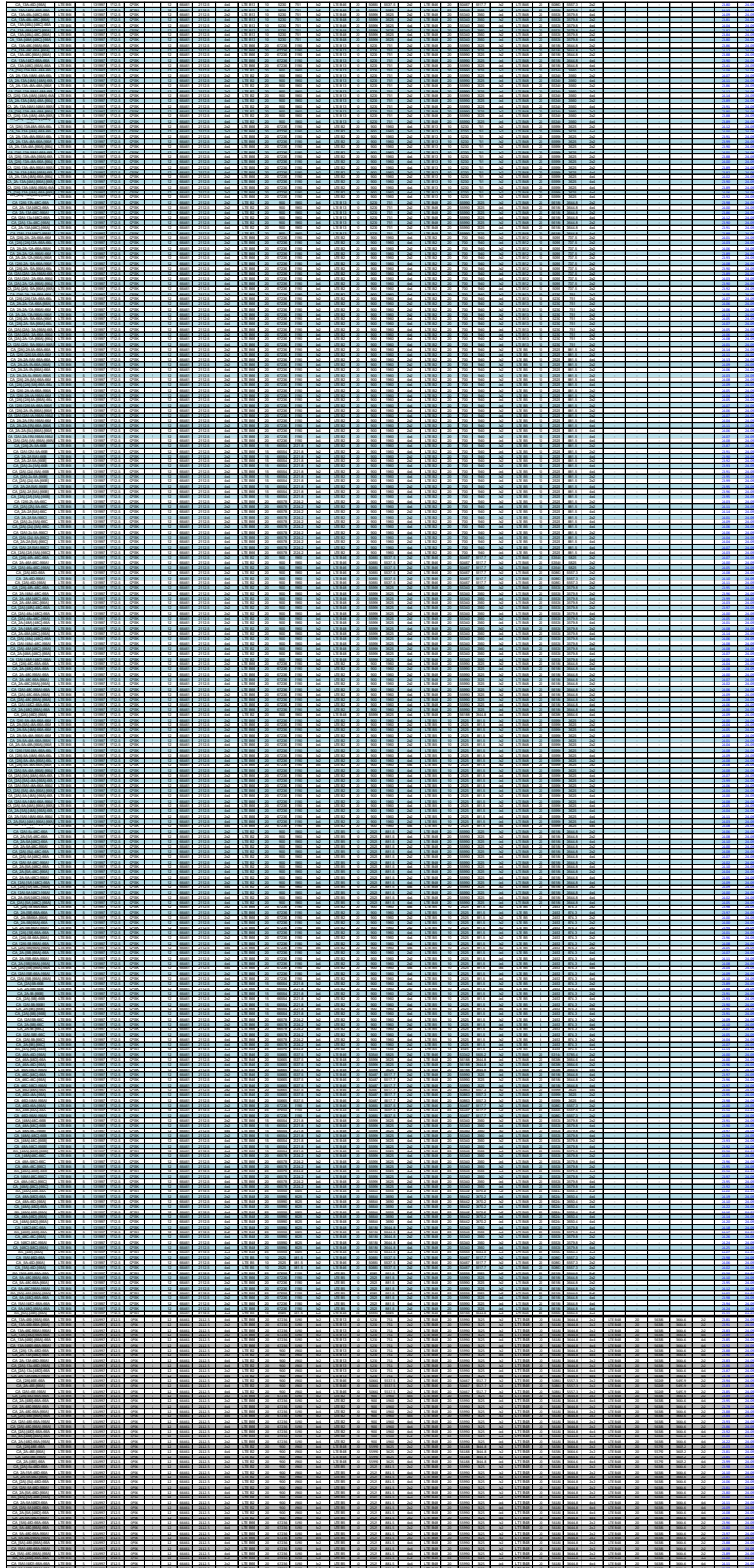

FCC ID: PY7-76056F	SAR EVALUATION REPORT	Approved by: Technical Manager
DUT Type: Portable Handset		APPENDIX J: Page 9 of 10

J.3.6 LTE Band 41 as PCC

Table J-16
Maximum Output Powers

Combination	PCC										SCC 1				SCC 2				SCC 3				SCC 4				Power								
	PCC Band	PCC BW [MHz]	PCC (UL) Ch.	PCC (UL) Freq. [MHz]	Mod.	PCC UL RB	PCC UL RB Offset	PCC (DL) Ch.	PCC (DL) Freq. [MHz]	DL Ant. Config.	SCC Band	SCC BW [MHz]	SCC (DL) Ch.	SCC (DL) Freq. [MHz]	DL Ant. Config.	SCC Band	SCC BW [MHz]	SCC (DL) Ch.	SCC (DL) Freq. [MHz]	DL Ant. Config.	SCC Band	SCC BW [MHz]	SCC (DL) Ch.	SCC (DL) Freq. [MHz]	DL Ant. Config.	SCC Band	SCC BW [MHz]	SCC (DL) Ch.	SCC (DL) Freq. [MHz]	DL Ant. Config.	LTE Tx Power with DL CA Enabled [dBm]	LTE Single Carrier Tx Power [dBm]			
CA 41A1-46A	LTE B41	20	40620	2593	QPSK	1	0	40620	2593	4x4	LTE B46	20	50661	5537.5	2x2	-	-	-	-	-	-	-	-	-	-	-	-	-	-	-	23.55	23.45			
CA 41C1 (1)	LTE B41	20	40620	2593	QPSK	1	0	40620	2593	4x4	LTE B41	20	40618	2612.8	4x4	-	-	-	-	-	-	-	-	-	-	-	-	-	-	-	-	23.55	23.45		
CA 41A1-46C	LTE B41	20	40620	2593	QPSK	1	0	40620	2593	4x4	LTE B46	20	50661	5537.5	2x2	LTE B46	20	50667	5517.7	2x2	-	-	-	-	-	-	-	-	-	-	-	-	23.55	23.45	
CA 41C1	LTE B41	20	40620	2593	QPSK	1	0	40620	2593	4x4	LTE B41	20	40612	2732.2	4x4	LTE B41	20	40618	2612.8	4x4	-	-	-	-	-	-	-	-	-	-	-	-	-	23.55	23.45
CA 41A1-46D	LTE B41	20	40620	2593	QPSK	1	0	40620	2593	4x4	LTE B46	20	50661	5537.5	2x2	LTE B46	20	50667	5517.7	2x2	LTE B46	20	50663	5557.3	2x2	-	-	-	-	-	-	-	-	23.38	23.45
CA 41A1-46E	LTE B41	20	40620	2593	QPSK	1	0	40620	2593	4x4	LTE B46	20	50661	5537.5	2x2	LTE B46	20	50667	5517.7	2x2	LTE B46	20	50663	5557.3	2x2	LTE B46	20	50661	5577.1	2x2	-	-	23.37	23.45	

J.3.1 LTE Band 48 as PCC

Table J-17
Maximum Output Powers

Combination	PCC										SCC 1				SCC 2				SCC 3				SCC 4				Power									
	PCC Band	PCC BW [MHz]	PCC (UL) Ch.	PCC (UL) Freq. [MHz]	Mod.	PCC UL RB	PCC UL RB Offset	PCC (DL) Ch.	PCC (DL) Freq. [MHz]	DL Ant. Config.	SCC Band	SCC BW [MHz]	SCC (DL) Ch.	SCC (DL) Freq. [MHz]	DL Ant. Config.	SCC Band	SCC BW [MHz]	SCC (DL) Ch.	SCC (DL) Freq. [MHz]	DL Ant. Config.	SCC Band	SCC BW [MHz]	SCC (DL) Ch.	SCC (DL) Freq. [MHz]	DL Ant. Config.	SCC Band	SCC BW [MHz]	SCC (DL) Ch.	SCC (DL) Freq. [MHz]	DL Ant. Config.	LTE Tx Power with DL CA Enabled [dBm]	LTE Single Carrier Tx Power [dBm]				
CA 48A1-48A	LTE B48	5	58715	3897.5	QPSK	1	12	58715	3897.5	2x2	LTE B48	20	55340	3560	4x4	-	-	-	-	-	-	-	-	-	-	-	-	-	-	-	-	23.85	23.97			
CA 48B1-48A	LTE B48	5	58715	3897.5	QPSK	1	12	58715	3897.5	4x4	LTE B48	20	55340	3560	2x2	-	-	-	-	-	-	-	-	-	-	-	-	-	-	-	-	-	23.98	23.97		
CA 48A1-48B	LTE B48	5	58715	3897.5	QPSK	1	12	58715	3897.5	4x4	LTE B48	20	55340	3560	2x2	LTE B48	20	55338	3579.8	2x2	-	-	-	-	-	-	-	-	-	-	-	-	-	23.98	23.97	
CA 48C1-48A	LTE B48	5	58715	3897.5	QPSK	1	12	58715	3897.5	2x2	LTE B48	20	55340	3560	4x4	LTE B48	20	55340	3560	4x4	-	-	-	-	-	-	-	-	-	-	-	-	-	23.95	23.97	
CA 48A1-48C	LTE B48	5	58715	3897.5	QPSK	1	12	58715	3897.5	4x4	LTE B48	20	55340	3560	4x4	LTE B48	20	55340	3560	4x4	-	-	-	-	-	-	-	-	-	-	-	-	-	23.98	23.97	
CA 48C1-48B	LTE B48	5	58715	3897.5	QPSK	1	12	58715	3897.5	2x2	LTE B48	20	55340	3560	4x4	LTE B48	20	55340	3560	4x4	-	-	-	-	-	-	-	-	-	-	-	-	-	-	23.94	23.97
CA 48C1-48A	LTE B48	5	58715	3897.5	QPSK	1	12	58715	3897.5	4x4	LTE B48	20	55340	3560	4x4	LTE B48	20	55340	3560	2x2	-	-	-	-	-	-	-	-	-	-	-	-	-	-	23.93	23.97
CA 48A1-48D	LTE B48	5	58715	3897.5	QPSK	1	12	58715	3897.5	4x4	LTE B48	20	55340	3560	2x2	LTE B48	20	55338	3579.8	2x2	LTE B48	20	55736	3599.6	2x2	-	-	-	-	-	-	-	-	-	23.98	23.97
CA 48B1-48D	LTE B48	5	58715	3897.5	QPSK	1	12	58715	3897.5	2x2	LTE B48	20	55340	3560	4x4	LTE B48	20	55338	3579.8	4x4	LTE B48	20	55736	3599.6	4x4	-	-	-	-	-	-	-	-	-	23.96	23.97
CA 48A1-48E	LTE B48	5	58715	3897.5	QPSK	1	12	58715	3897.5	4x4	LTE B48	20	55340	3560	4x4	LTE B48	20	55338	3579.8	4x4	LTE B48	20	55736	3599.6	4x4	-	-	-	-	-	-	-	-	-	23.95	23.97
CA 48C1-48C	LTE B48	5	58715	3897.5	QPSK	1	12	58715	3897.5	2x2	LTE B48	20	55340	3560	4x4	LTE B48	20	55340	3560	4x4	LTE B48	20	55338	3579.8	4x4	-	-	-	-	-	-	-	-	-	23.98	23.97
CA 48C1-48C	LTE B48	5	58715	3897.5	QPSK	1	12	58715	3897.5	4x4	LTE B48	20	55340	3560	4x4	LTE B48	20	55340	3560	2x2	LTE B48	20	55338	3579.8	2x2	-	-	-	-	-	-	-	-	-	23.95	23.97
CA 48C1-48C	LTE B48	5	58715	3897.5	QPSK	1	12	58715	3897.5	4x4	LTE B48	20	55340	3560	4x4	LTE B48	20	55340	3560	4x4	LTE B48	20	55338	3579.8	4x4	-	-	-	-	-	-	-	-	-	23.93	23.97
CA 48A1-48E	LTE B48	5	58715	3897.5	QPSK	1	12	58715	3897.5	4x4	LTE B48	20	55340	3560	2x2	LTE B48	20	55338	3579.8	2x2	LTE B48	20	55736	3599.6	2x2	LTE B48	20	55934	3619.4	2x2	-	-	-	-	23.92	23.97
CA 48B1-48E	LTE B48	5	58715	3897.5	QPSK	1	12	58715	3897.5	2x2	LTE B48	20	55340	3560	4x4	LTE B48	20	55338	3579.8	4x4	LTE B48	20	55736	3599.6	4x4	LTE B48	20	55934	3619.4	4x4	-	-	-	-	23.94	23.97
CA 48A1-48E	LTE B48	5	58715	3897.5	QPSK	1	12	58715	3897.5	4x4	LTE B48	20	55340	3560	4x4	LTE B48	20	55338	3579.8	4x4	LTE B48	20	55736	3599.6	4x4	LTE B48	20	55934	3619.4	4x4	-	-	-	-	23.94	23.97

FCC ID: PY7-76056F	SAR EVALUATION REPORT	Approved by: Technical Manager
DUT Type: Portable Handset		APPENDIX J: Page 10 of 10