



# **CERTIFICATION TEST REPORT**

**Report Number. :** 12132731-E4V3

**Applicant :** SONY MOBILE COMMUNICATIONS, INC.  
4-12-3 HIGASHI-SHINAGAWA,  
SHINAGAWA -KU, TOKYO, 140-0002, JAPAN

**FCC ID :** PY7-68553C

**EUT Description :** GSM/WCDMA/LTE Phone with BT, DTS/UNII a/b/g/n/ac &  
NFC

**Test Standard(s) :** FCC 47 CFR PART 15 SUBPART C

**Date Of Issue:**

May 04, 2018

**Prepared by:**

UL Verification Services Inc.  
47173 Benicia Street  
Fremont, CA 94538, U.S.A.  
TEL: (510) 771-1000  
FAX: (510) 661-0888



## REPORT REVISION HISTORY

Rev.	Issue Date	Revisions	Revised By
V1	4/19/2018	Initial Issue	
V2	5/2/2018	Updated Section 5.3 & 8.3.3	Kiya Kedida
V3	5/4/2018	Updated Section 5.5	Kiya Kedida

## TABLE OF CONTENTS

<b>REPORT REVISION HISTORY .....</b>	<b>2</b>
<b>TABLE OF CONTENTS .....</b>	<b>3</b>
<b>1. ATTESTATION OF TEST RESULTS .....</b>	<b>5</b>
<b>2. TEST METHODOLOGY .....</b>	<b>6</b>
<b>3. FACILITIES AND ACCREDITATION .....</b>	<b>6</b>
<b>4. CALIBRATION AND UNCERTAINTY .....</b>	<b>7</b>
4.1. MEASURING INSTRUMENT CALIBRATION .....	7
4.2. SAMPLE CALCULATION .....	7
4.3. MEASUREMENT UNCERTAINTY.....	7
<b>5. EQUIPMENT UNDER TEST.....</b>	<b>8</b>
5.1. EUT DESCRIPTION.....	8
5.2. MAXIMUM OUTPUT POWER.....	8
5.3. DESCRIPTION OF AVAILABLE ANTENNAS.....	8
5.4. SOFTWARE AND FIRMWARE.....	8
5.5. WORST-CASE CONFIGURATION AND MODE.....	9
5.6. DESCRIPTION OF TEST SETUP.....	10
<b>6. MEASUREMENT METHOD.....</b>	<b>13</b>
<b>7. TEST AND MEASUREMENT EQUIPMENT .....</b>	<b>14</b>
<b>8. ANTENNA PORT TEST RESULTS .....</b>	<b>15</b>
8.1. ON TIME AND DUTY CYCLE.....	15
8.2. 6 dB BANDWIDTH.....	17
8.2.1. 802.11b MODE .....	18
8.2.2. 802.11g MODE .....	21
8.2.3. 802.11n HT20 MODE .....	24
8.3. OUTPUT POWER.....	27
8.3.1. 802.11b MODE .....	28
8.3.2. 802.11g MODE .....	29
8.3.3. 802.11n HT20 MODE .....	30
8.4. POWER SPECTRAL DENSITY.....	31
8.4.1. 802.11b MODE .....	32
8.4.2. 802.11g MODE .....	36
8.4.3. 802.11n HT20 MODE .....	40
8.5. CONDUCTED SPURIOUS EMISSIONS.....	44
8.5.1. 802.11b MODE .....	45
8.5.2. 802.11g MODE .....	49
8.5.3. 802.11n HT20 MODE .....	53

---

<b>9. RADIATED TEST RESULTS.....</b>	<b>57</b>
9.1. TRANSMITTER ABOVE 1 GHz.....	58
9.1.1. TX ABOVE 1 GHz 802.11b MODE IN THE 2.4 GHz BAND .....	58
9.1.2. TX ABOVE 1 GHz 802.11g MODE IN THE 2.4 GHz BAND .....	72
9.1.3. TX ABOVE 1 GHz 802.11n HT20 MODE IN THE 2.4 GHz BAND.....	86
9.1. WORST-CASE BELOW 30 MHz.....	100
9.2. Worst Case Below 1 GHz .....	101
9.3. Worst Case 18-26 GHz.....	103
<b>10. AC POWER LINE CONDUCTED EMISSIONS.....</b>	<b>105</b>
<b>11. SETUP PHOTOS.....</b>	<b>108</b>

# 1. ATTESTATION OF TEST RESULTS

**COMPANY NAME:** SONY MOBILE COMMUNICATIONS, INC.  
4-12-3 HIGASHI-SHINAGAWA,  
SHINAGAWA -KU, TOKYO, 140-0002, JAPAN

**EUT DESCRIPTION:** GSM/WCDMA/LTE Phone with BT, DTS/UNII a/b/g/n/ac &  
NFC

**SERIAL NUMBER:** CB512FH68Z (RADIATED)  
CB512FHBUA (CONDUCTED)

**DATE TESTED:** March 22 to April 06, 2018

APPLICABLE STANDARDS	
STANDARD	TEST RESULTS
CFR 47 Part 15 Subpart C	Complies

UL Verification Services Inc. tested the above equipment in accordance with the requirements set forth in the above standards. All indications of Pass/Fail in this report are opinions expressed by UL Verification Services Inc. based on interpretations and/or observations of test results. Measurement Uncertainties were not taken into account and are published for informational purposes only. The test results show that the equipment tested is capable of demonstrating compliance with the requirements as documented in this report.

**Note:** The results documented in this report apply only to the tested sample, under the conditions and modes of operation as described herein. This document may not be altered or revised in any way unless done so by UL Verification Services Inc. and all revisions are duly noted in the revisions section. Any alteration of this document not carried out by UL Verification Services Inc. will constitute fraud and shall nullify the document. This report must not be used by the client to claim product certification, approval, or endorsement by NVLAP, NIST, any agency of the Federal Government, or any agency of the U.S. government.

Approved & Released For  
UL Verification Services Inc. By:

Reviewed By:



Dan Corona  
CONSUMER TECHNOLOGY DIVISION  
Operations Leader  
UL Verification Services Inc.

Kiya Kedida  
CONSUMER TECHNOLOGY DIVISION  
Project Engineer  
UL Verification Services Inc.

## 2. TEST METHODOLOGY

The tests documented in this report were performed in accordance with FCC CFR 47 Part 2, FCC CFR 47 Part 15, KDB 558074 D01 v04, KDB 662911 D01 v02r01 and ANSI C63.10-2013.

## 3. FACILITIES AND ACCREDITATION

The test sites and measurement facilities used to collect data are located at 47173 and 47266 Benicia Street, Fremont, California, USA. Line conducted emissions are measured only at the 47173 address. The following table identifies which facilities were utilized for radiated emission measurements documented in this report. Specific facilities are also identified in the test results sections.

47173 Benicia Street	47266 Benicia Street
<input checked="" type="checkbox"/> Chamber A (ISED:2324B-1)	<input type="checkbox"/> Chamber D (ISED:22541-1)
<input checked="" type="checkbox"/> Chamber B (ISED:2324B-2)	<input type="checkbox"/> Chamber E (ISED:22541-2)
<input checked="" type="checkbox"/> Chamber C (ISED:2324B-3)	<input type="checkbox"/> Chamber F (ISED:22541-3)
	<input type="checkbox"/> Chamber G (ISED:22541-4)
	<input type="checkbox"/> Chamber H (ISED:22541-5)

The above test sites and facilities are covered under FCC Test Firm Registration # 208313. Chambers A through C are covered under ISED company address code 2324B with site numbers 2324B -1 through 2324B-3, respectively. Chambers D through H are covered under ISED company address code 22541 with site numbers 22541 -1 through 22541-5, respectively.

UL Verification Services Inc. is accredited by NVLAP, Laboratory Code 200065-0. The full scope of accreditation can be viewed at <http://nist.gov/standards/scopes/2000650.htm>.

## 4. CALIBRATION AND UNCERTAINTY

### 4.1. MEASURING INSTRUMENT CALIBRATION

The measuring equipment utilized to perform the tests documented in this report has been calibrated in accordance with the manufacturer's recommendations, and is traceable to recognized national standards.

### 4.2. SAMPLE CALCULATION

Where relevant, the following sample calculation is provided:

$$\begin{aligned} \text{Field Strength (dBuV/m)} &= \text{Measured Voltage (dBuV)} + \text{Antenna Factor (dB/m)} + \\ &\text{Cable Loss (dB)} - \text{Preamp Gain (dB)} \\ 36.5 \text{ dBuV} + 18.7 \text{ dB/m} + 0.6 \text{ dB} - 26.9 \text{ dB} &= 28.9 \text{ dBuV/m} \end{aligned}$$

### 4.3. MEASUREMENT UNCERTAINTY

Where relevant, the following measurement uncertainty levels have been estimated for tests performed on the apparatus:

PARAMETER	UNCERTAINTY
Worst Case Conducted Disturbance, 9KHz to 0.15 MHz	3.84 dB
Worst Case Conducted Disturbance, 0.15 to 30 MHz	3.65 dB
Worst Case Radiated Disturbance, 9KHz to 30 MHz	3.15 dB
Worst Case Radiated Disturbance, 30 to 1000 MHz	5.36 dB
Worst Case Radiated Disturbance, 1000 to 18000 MHz	4.32 dB
Worst Case Radiated Disturbance, 18000 to 26000 MHz	4.45 dB
Worst Case Radiated Disturbance, 26000 to 40000 MHz	5.24 dB

Uncertainty figures are valid to a confidence level of 95%.

## 5. EQUIPMENT UNDER TEST

### 5.1. EUT DESCRIPTION

The EUT is a GSM/WCDMA/LTE Phone with BT, DTS/UNII a/b/g/n/ac & NFC.

### 5.2. MAXIMUM OUTPUT POWER

The transmitter has a maximum conducted output power as follows:

Frequency Range (MHz)	Mode	Output Power (dBm)	Output Power (mW)
<b>2Tx</b>			
2412 - 2472	802.11b	12.50	17.78
2412 - 2472	802.11g	12.39	17.34
2412 - 2472	802.11n HT20 CDD	12.49	17.74

### 5.3. DESCRIPTION OF AVAILABLE ANTENNAS

The radio utilizes a loop antenna for chain 0 and a monopole antenna for chain 1, with the maximum gains:

Frequency Band (GHz)	Antenna Gain (dBi) Chain 0	Antenna Gain (dBi) Chain 1
2402-2480	-1.20	-9.30

### 5.4. SOFTWARE AND FIRMWARE

The firmware installed in the EUT during testing was s\_atp\_XXX\_0\_00403\_A\_9.  
The test utility software used during testing was Tera Term Ver 4.79.



---

## 5.5. WORST-CASE CONFIGURATION AND MODE

Radiated emissions below 30MHz, 1GHz, above 18GHz, and AC power line conducted emission were performed with the EUT set to transmit at the channel with highest output power as a worst-case scenario.

Band edge and radiated emissions between 1GHz and 18GHz were performed with the EUT set to transmit at the highest power on low, middle and high channels.

The fundamental of the EUT was investigated in three orthogonal orientations X, Y, & Z, and it was determined that Z-Axis with AC/DC Adapter was worst-case orientation; therefore, all final radiated testing was performed with the EUT in Z-Axis with AC/DC Adapter orientation.

Worst-case data rates as provided by the client were:

802.11b mode: 1 Mbps

802.11g mode: 6 Mbps

802.11n HT20mode: MCS0

The simultaneous mode (SISO 2.4GHz Chain 0 and 5GHz chain 1) was checked and stand-alone (MIMO) 2.4 GHz / 5GHz remain the worst case.

NOTE: SISO mode is covered by MIMO mode due to same maximum tune-up limit (power).

## 5.6. DESCRIPTION OF TEST SETUP

### SUPPORT EQUIPMENT

Support Equipment List				
Description	Manufacturer	Model	Serial Number	FCC ID
Laptop	Lenovo	20B7S0A200	PC015REW	NA
AC Adapter	SONY	UCH12	4016W40310044	NA
DC Power Supply	Ametek	XT 15-4	T463	N/A

### I/O CABLES (CONDUCTED TEST)

I/O Cable List						
Cable No	Port	# of identical ports	Connector Type	Cable Type	Cable Length (m)	Remarks
1	Antenna	1	RF	Shielded	0.2	To spectrum Analyzer
2	USB	1	USB	Shielded	1	N/A
3	DC	1	DC	Shielded	0.3	N/A

### I/O CABLES (RADIATED AND CONDUCTED EMISSIONS)

I/O Cable List						
Cable No	Port	# of identical ports	Connector Type	Cable Type	Cable Length (m)	Remarks
1	USB	1	USB	Shielded	3	N/A

**TEST SETUP**

**SETUP DIAGRAM FOR CONDUCTED TESTS**

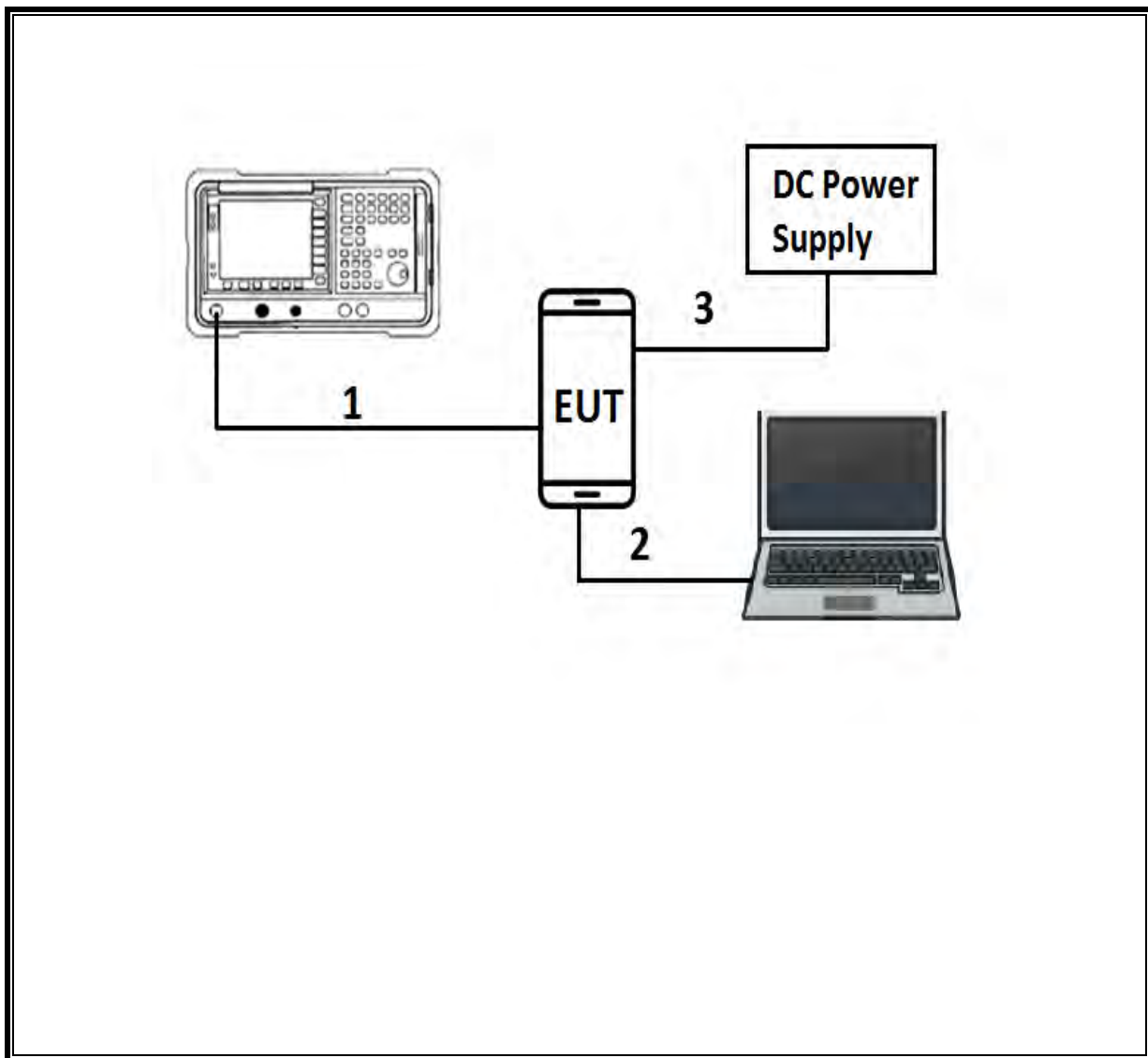

**TEST SETUP**

**RADIATED AND AC LINE CONDUCTED EMISSIONS SETUP DIAGRAM**

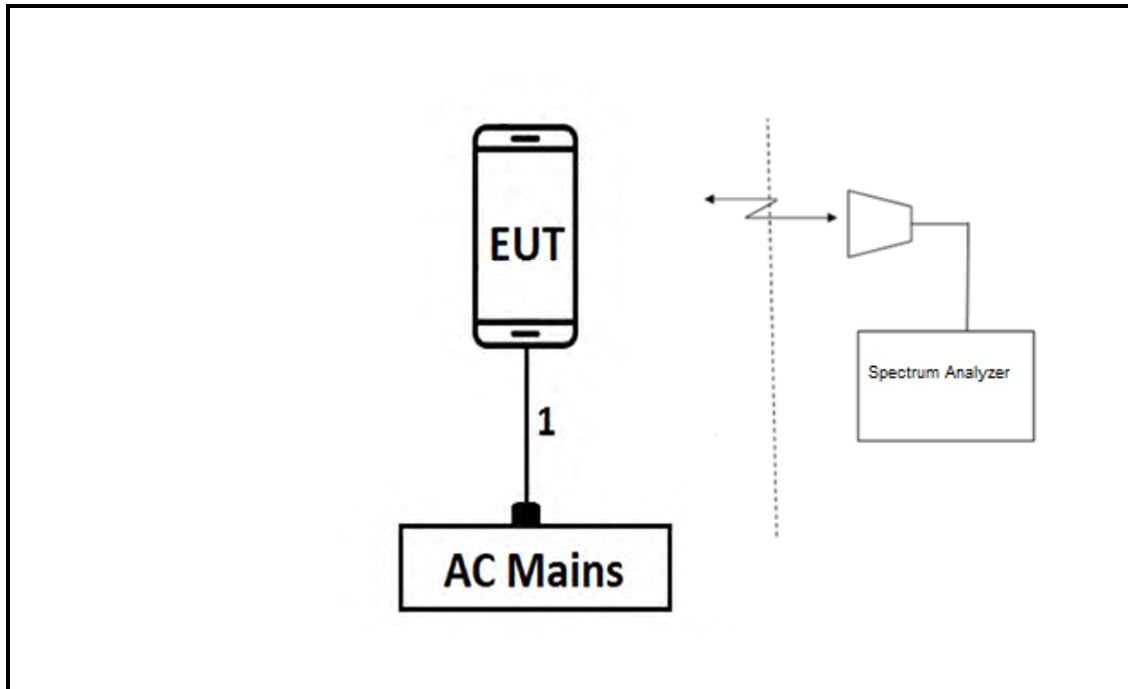

## 6. MEASUREMENT METHOD

On Time and Duty Cycle: KDB 558074 D01 v04, Section 6.

6 dB BW: KDB 558074 D01 v04, Section 8.1.

Output Power: KDB 558074 D01 v04, Section 9.2.3.2.

Power Spectral Density: KDB 558074 D01 v04, Section 10.3 & 10.5.

Out-of-band emissions in non-restricted bands: KDB 558074 D01 v04, Section 11.1 (b).

Out-of-band emissions in restricted bands: KDB 558074 D01 v04, Section 12.1.

Band-edge: KDB 558074 D01 v04, Section 12.1.

AC Power Line Conducted Emissions: ANSI C63.10-2013, Section 6.2.

## 7. TEST AND MEASUREMENT EQUIPMENT

The following test and measurement equipment was utilized for the tests documented in this report:

<b>TEST EQUIPMENT LIST</b>				
<b>Description</b>	<b>Manufacturer</b>	<b>Model</b>	<b>Asset</b>	<b>Cal Due</b>
Amplifier, 10KHz to 1GHz, 32dB	Agilent (Keysight) Technologies	8447D	T15	08/14/2018
Amplifier, 1 - 18GHz	MITEQ	AFS42-00101800-25-S-42	T931	09/20/2018
Amplifier, 1 to 18GHz	Miteq	AFS42-00101800-25-S-42	T1165	11/25/2018
RF Preamplifier, 1 - 26GHz	Agilent	8449B	T404	07/23/2018
Antenna, Active Loop 9kHz-30MHz	Com-Power Corp.	AL-130R	T1866	10/10/2018
Antenna, Broadband Hybrid, 30MHz to 2000MHz	Sunol Sciences Corp.	JB3	T130	06/15/2018
Antenna, Horn 1-18GHz	ETS-Lindgren	3117	T120	06/26/2018
Antenna, Horn 1-18GHz	ETS-Lindgren	3117	T862	06/09/2018
Antenna Horn, 18 to 26GHz	ARA	MWH-1826	T89	01/18/2019
Power Meter, P-series single channel	Keysight	N1912A	T1245	05/12/2018
Power Sensor	Keysight	N1921A	T413	06/22/2018
Spectrum Analyzer, PXA, 3Hz to 44GHz	Agilent (Keysight) Technologies	N9030A	T1466	04/11/2018
Spectrum Analyzer, PXA, 3Hz to 44GHz	Agilent (Keysight) Technologies	N9030A	T1454	01/08/2019
Spectrum Analyzer, PXA, 3Hz to 44GHz	Agilent (Keysight) Technologies	N9030A	T1113	12/21/2018
Spectrum Analyzer, PXA, 3Hz to 44GHz	Agilent (Keysight) Technologies	N9030A	T1450	02/05/2019
<b>AC Line Conducted</b>				
EMI Test Receiver 9KHz-7GHz	Rohde & Schwarz	ESC17	T1124	11/07/2018
LISN for Conducted Emissions CISPR-16	Fischer	50/250-25-2-01	T1310	06/15/2018
Power Cable, Line Conducted Emissions	UL	PG1	T861	08/31/2018
<b>UL AUTOMATION SOFTWARE</b>				
Radiated Software	UL	UL EMC	Ver 9.5, Dec 01, 2016	
Antenna Port Software	UL	UL EMC	Ver 8.2, Feb 28, 2018	
AC Line Conducted Software	UL	UL EMC	Ver 9.5, May 26, 2015	

### **NOTES:**

1. Equipment listed above that calibrated during the testing period was set for test after the calibration.
2. Equipment listed above that has a calibration due date during the testing period, the testing is completed before equipment expiration date.

## 8. ANTENNA PORT TEST RESULTS

### 8.1. ON TIME AND DUTY CYCLE

#### LIMITS

None; for reporting purposes only.

#### PROCEDURE

KDB 789033 Zero-Span Spectrum Analyzer Method.

#### ON TIME AND DUTY CYCLE RESULTS

Mode	ON Time B (msec)	Period (msec)	Duty Cycle x (linear)	Duty Cycle (%)	Duty Cycle Correction Factor (dB)	1/B Minimum VBW (kHz)
<b>2.4GHz Band</b>						
802.11b 1TX	12.210	12.290	0.993	99.35%	0.00	0.010
802.11g 1TX	2.027	2.063	0.983	98.25%	0.00	0.010
802.11n HT20 1TX	2.511	2.578	0.974	97.40%	0.11	0.398

### DUTY CYCLE PLOTS

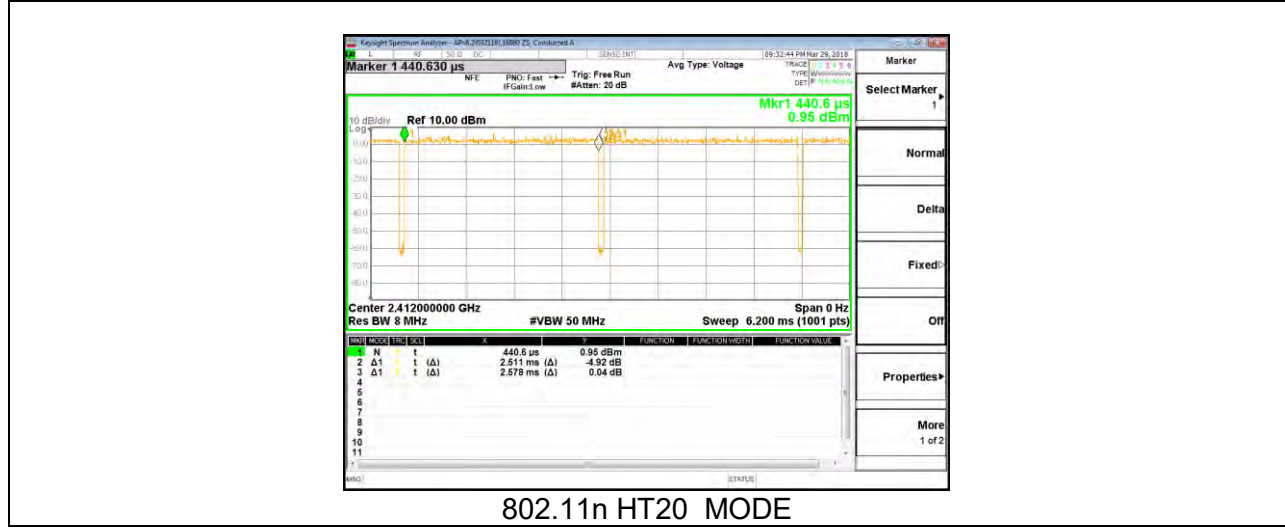
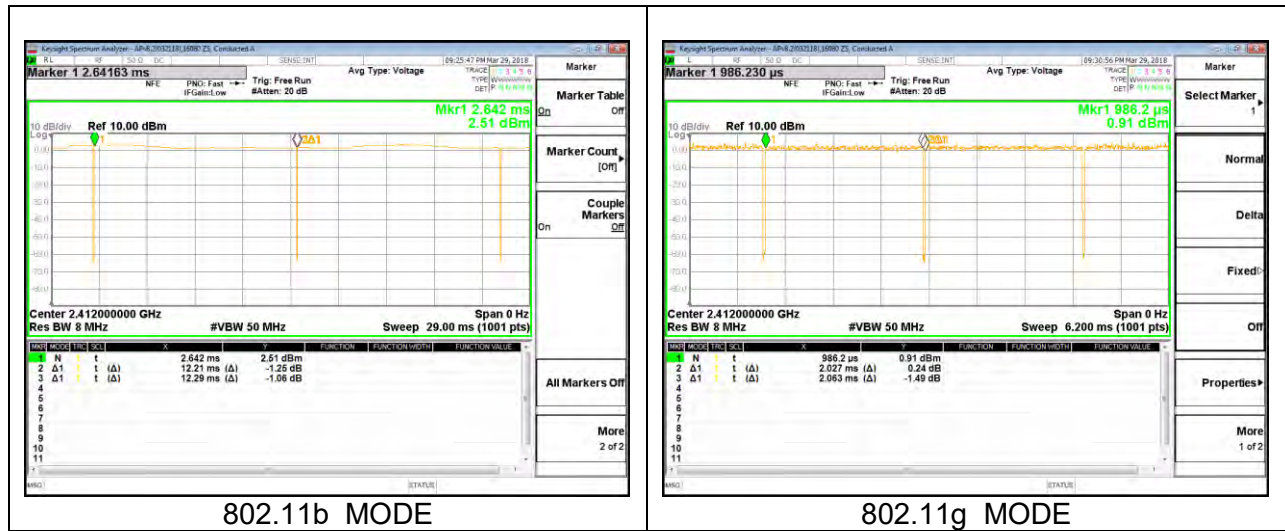



## **8.2. 6 dB BANDWIDTH**

### **LIMITS**

FCC §15.247 (a) (2)

The minimum 6 dB bandwidth shall be at least 500 kHz.

### **RESULTS**

### 8.2.1. 802.11b MODE

Channel	Frequency (MHz)	6 dB BW Chain 0 (MHz)	6 dB BW Chain 1 (MHz)	Minimum Limit (MHz)
Low 1	2412	7.64	8.12	0.5
Mid 6	2437	7.60	7.60	0.5
High 11	2462	6.60	7.32	0.5
High 12	2467	7.60	8.08	0.5
High 13	2472	8.08	7.04	0.5

#### LOW CHANNEL 1

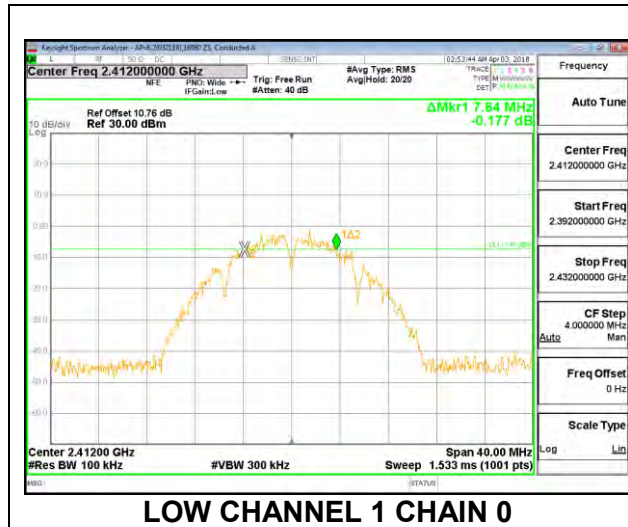

LOW CHANNEL 1 CHAIN 0

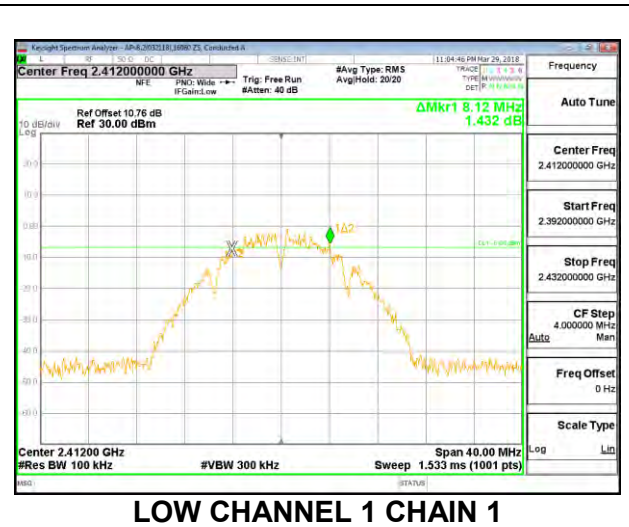

LOW CHANNEL 1 CHAIN 1

#### MID CHANNEL 6

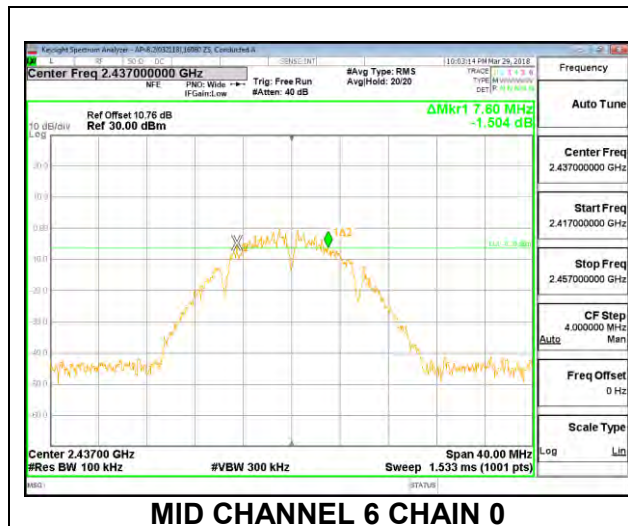

MID CHANNEL 6 CHAIN 0

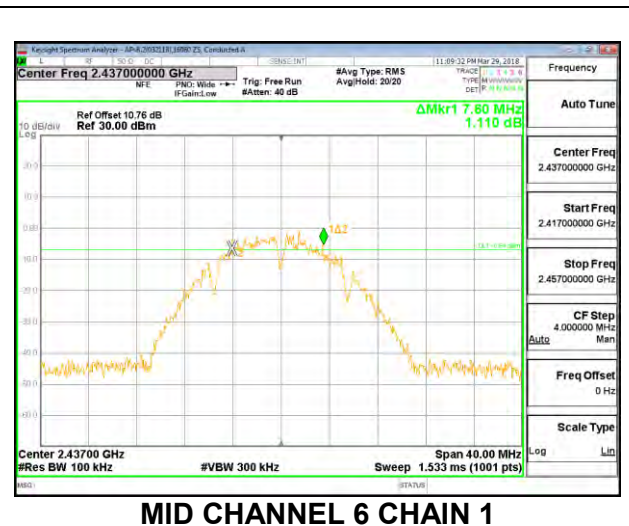

MID CHANNEL 6 CHAIN 1

### HIGH CHANNEL 11

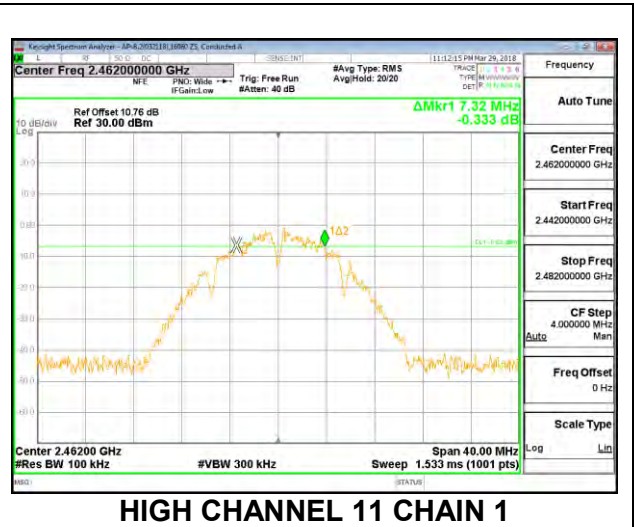
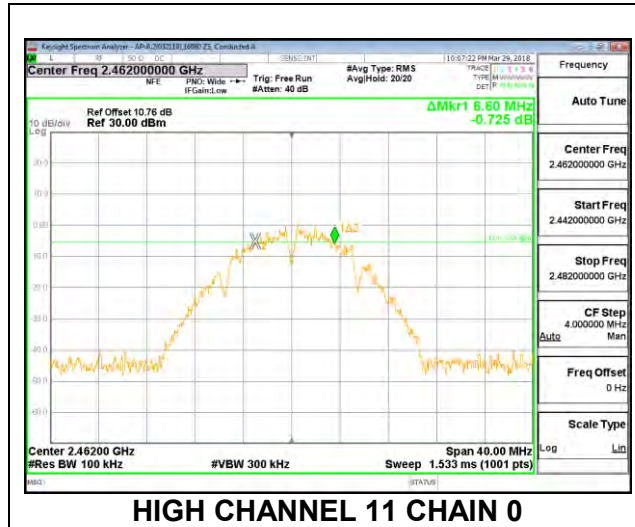

### HIGH CHANNEL 12

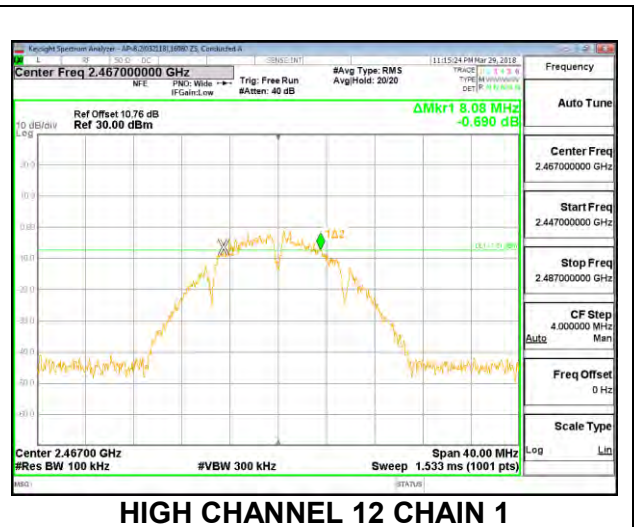
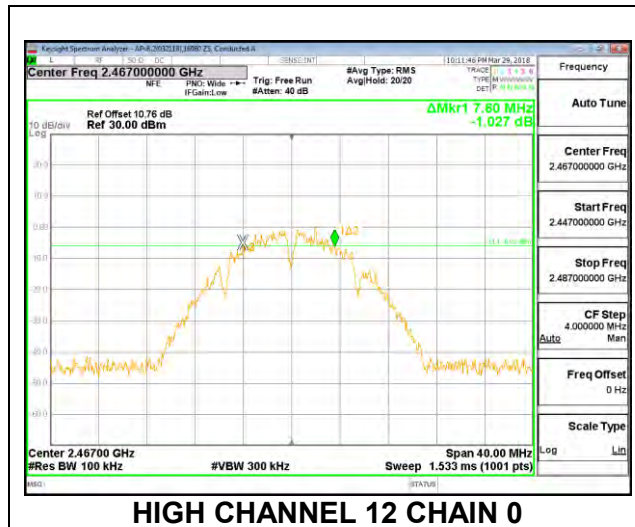

### HIGH CHANNEL 13

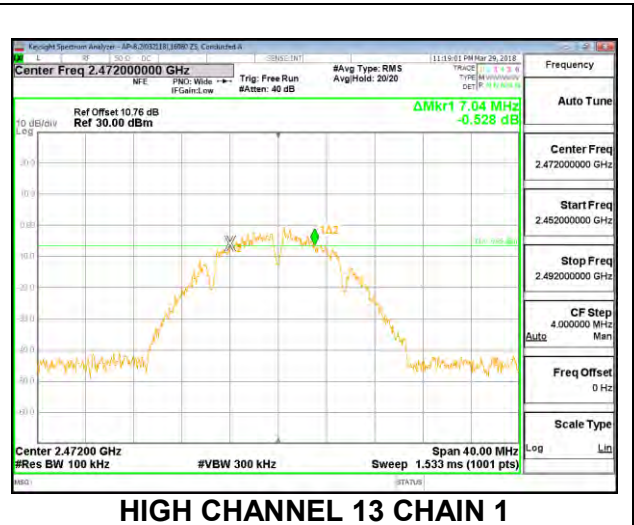
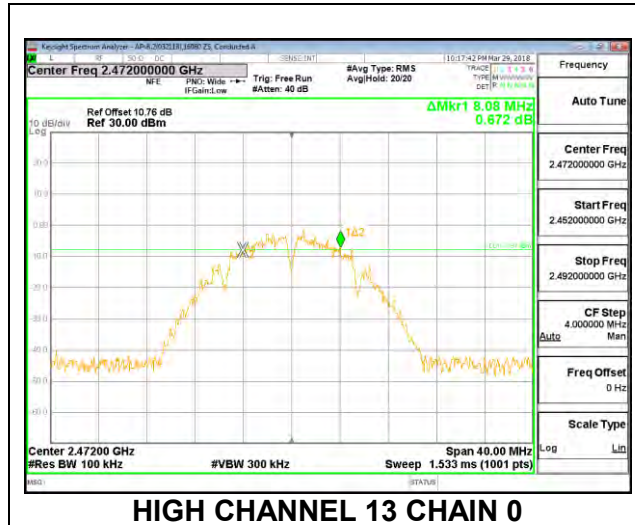

### 8.2.2. 802.11g MODE

Channel	Frequency (MHz)	6 dB BW Chain 0 (MHz)	6 dB BW Chain 1 (MHz)	Minimum Limit (MHz)
Low 1	2412	16.32	16.36	0.5
Mid 6	2437	16.52	16.48	0.5
High 11	2462	16.32	16.36	0.5
High 12	2467	16.36	16.32	0.5
High 13	2472	16.48	16.36	0.5

#### LOW CHANNEL 1

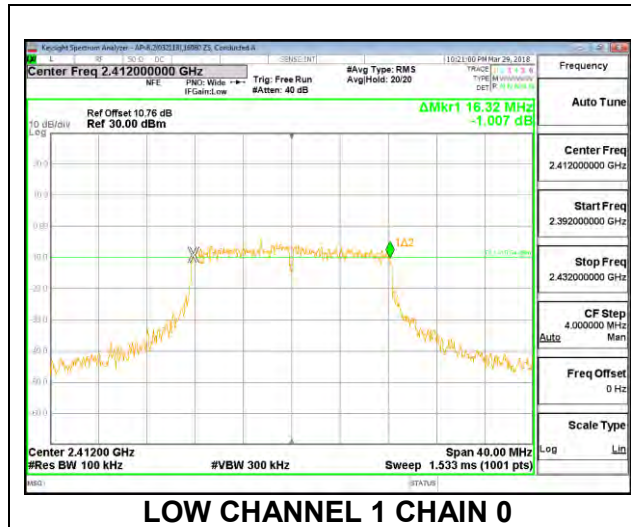

LOW CHANNEL 1 CHAIN 0

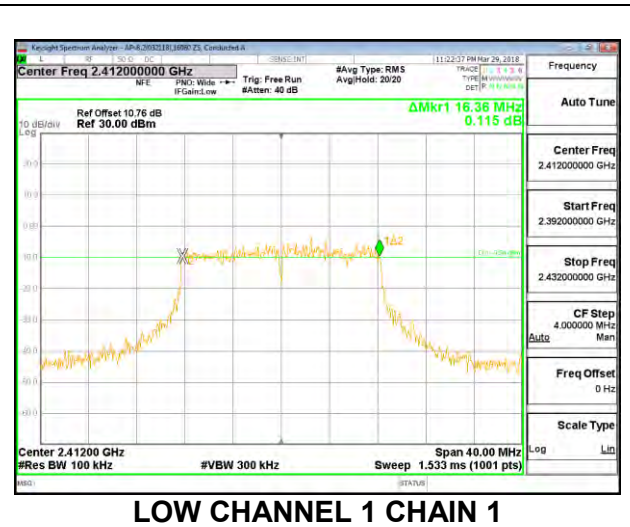

LOW CHANNEL 1 CHAIN 1

#### MID CHANNEL 6

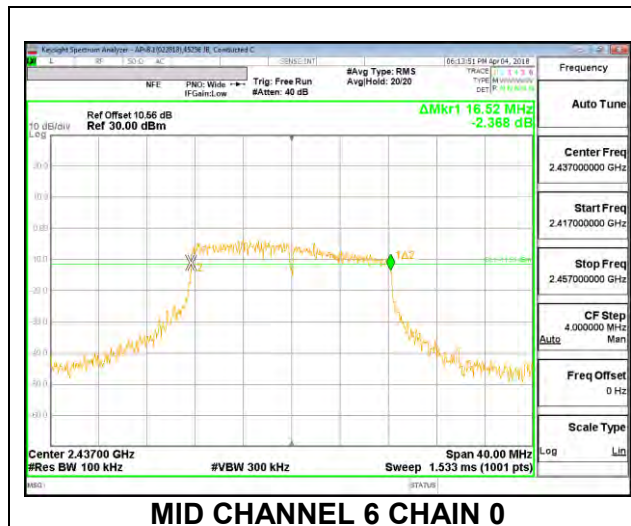

MID CHANNEL 6 CHAIN 0

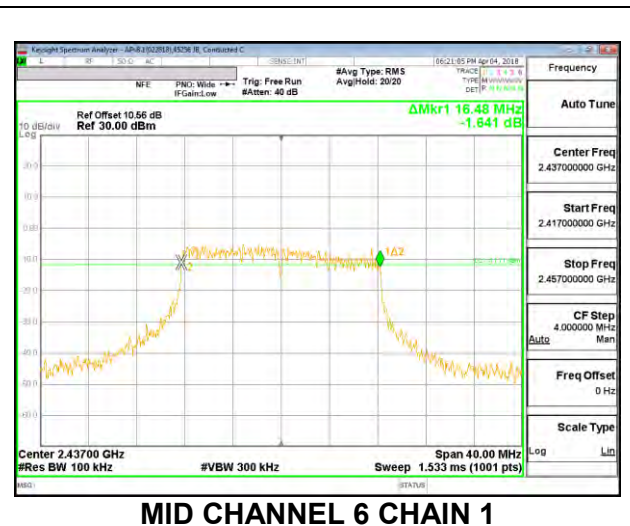

MID CHANNEL 6 CHAIN 1

### HIGH CHANNEL 11

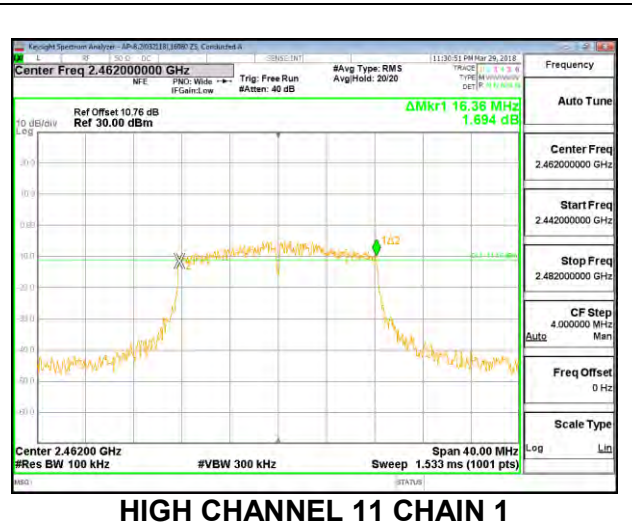
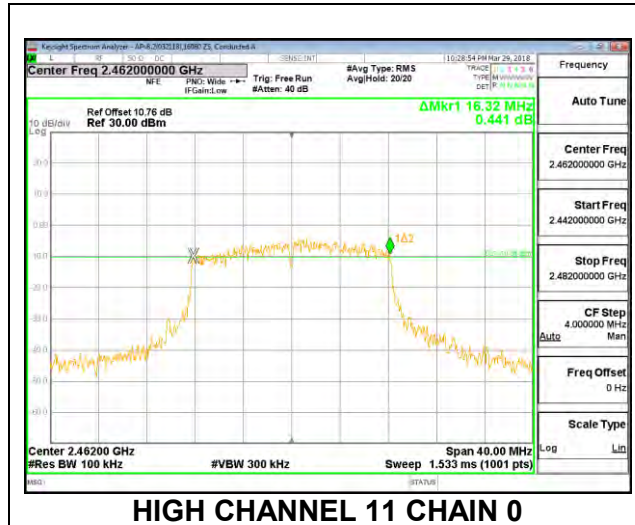

### HIGH CHANNEL 12

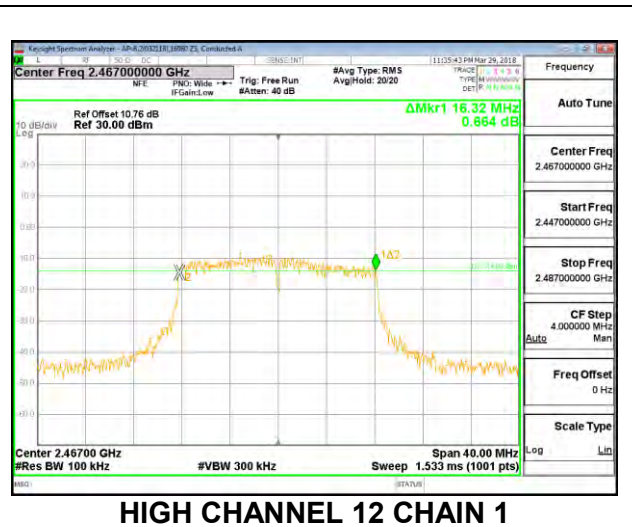
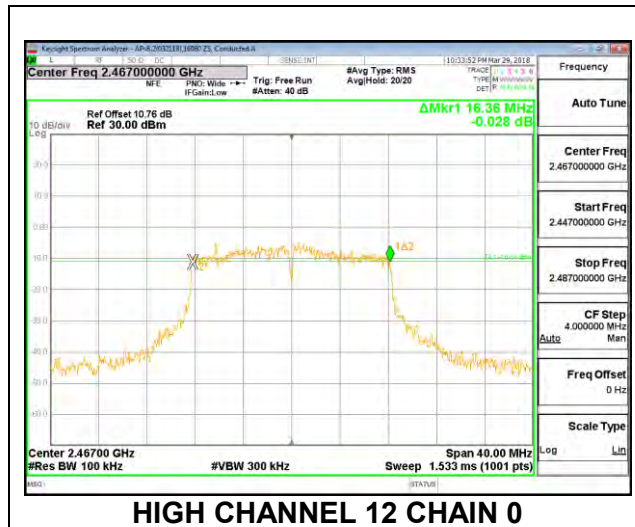

### HIGH CHANNEL 13

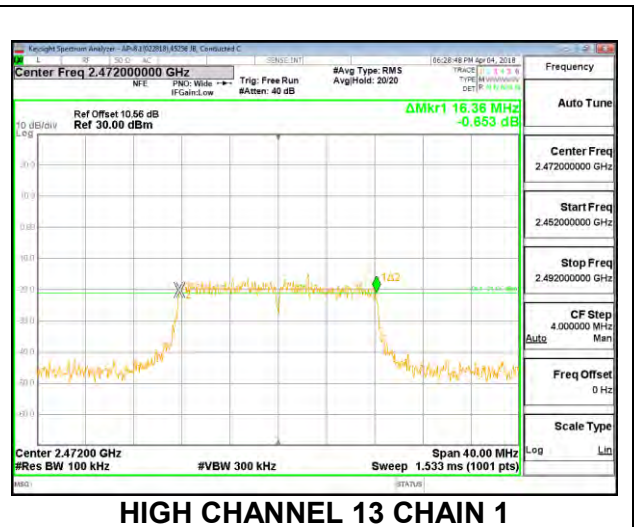
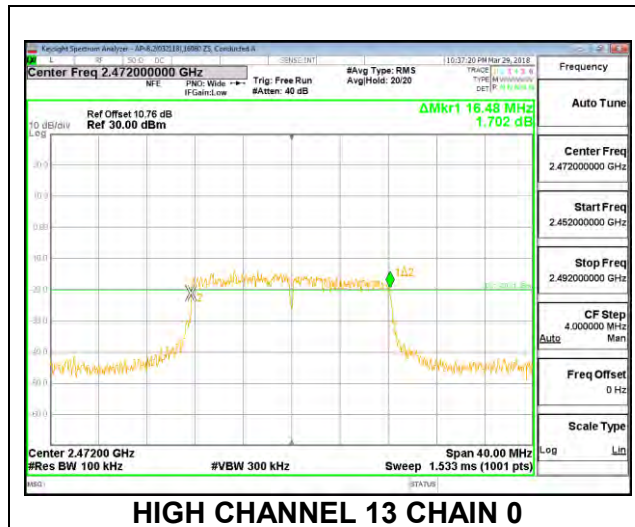

### 8.2.3. 802.11n HT20 MODE

Channel	Frequency (MHz)	6 dB BW Chain 0 (MHz)	6 dB BW Chain 1 (MHz)	Minimum Limit (MHz)
Low 1	2412	17.56	17.72	0.5
Mid 6	2437	17.32	17.68	0.5
High 11	2462	17.60	17.60	0.5
High 12	2467	17.60	17.20	0.5
High 13	2472	17.64	17.64	0.5

#### LOW CHANNEL 1

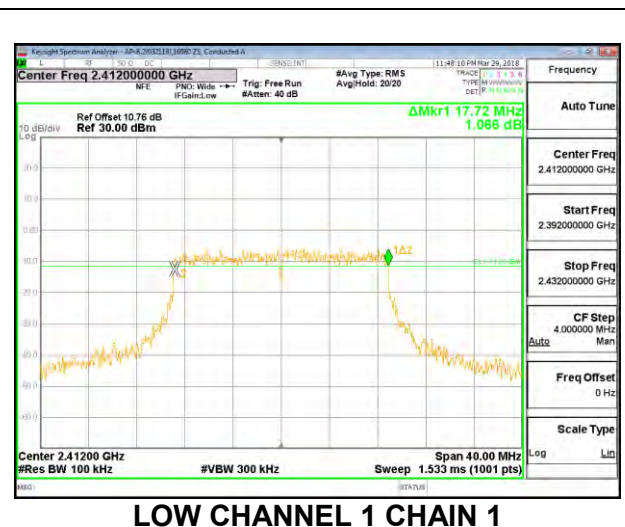
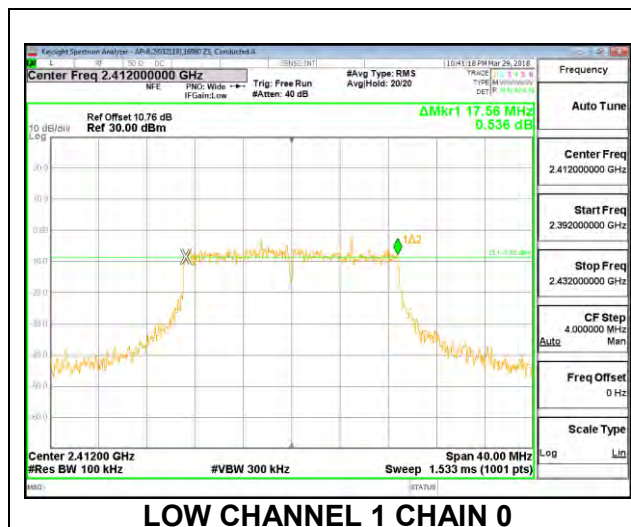

#### MID CHANNEL 6

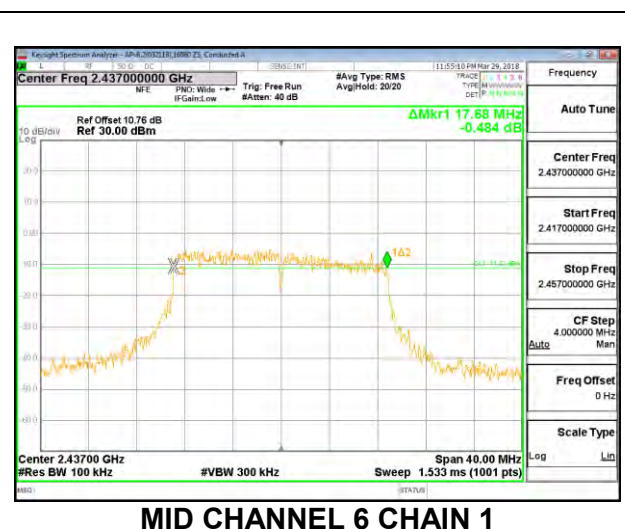
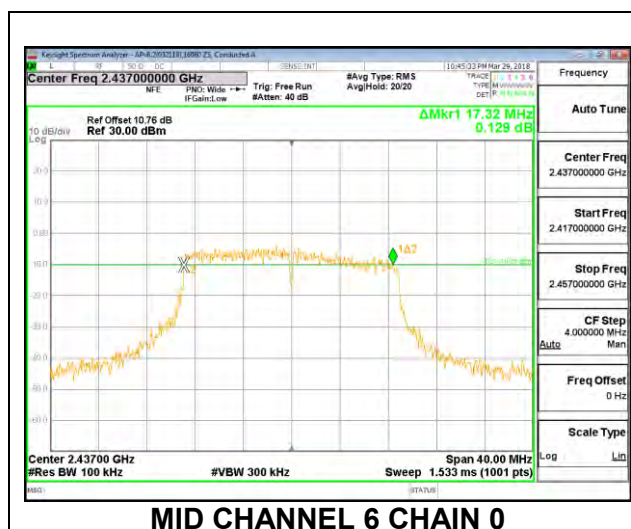



### HIGH CHANNEL 11

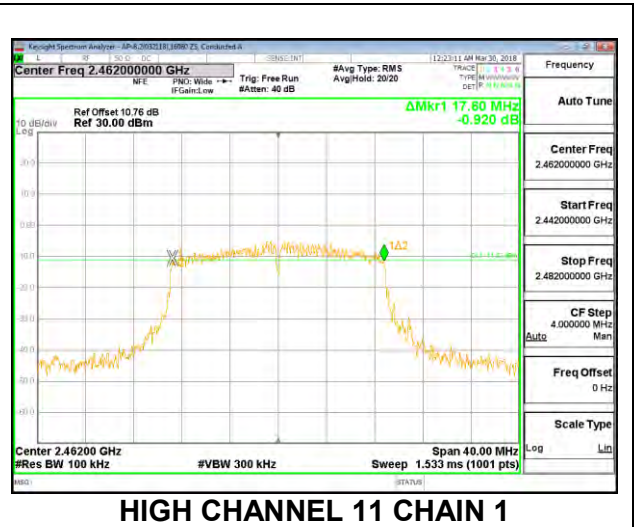
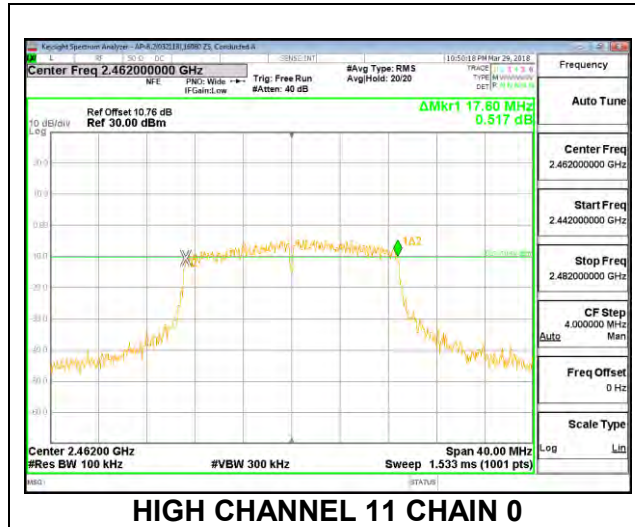

### HIGH CHANNEL 12

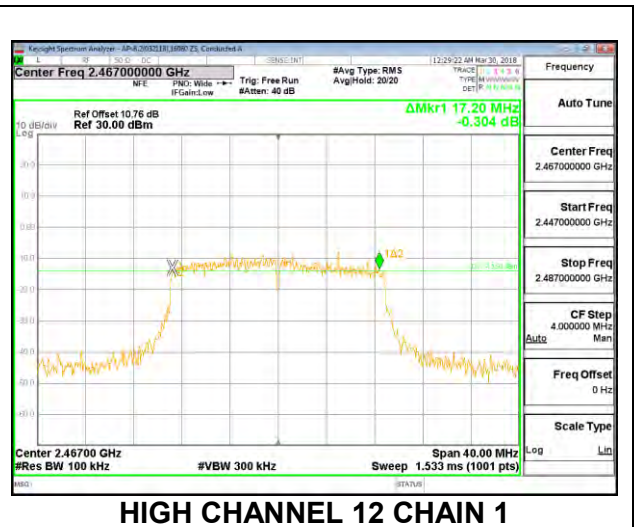
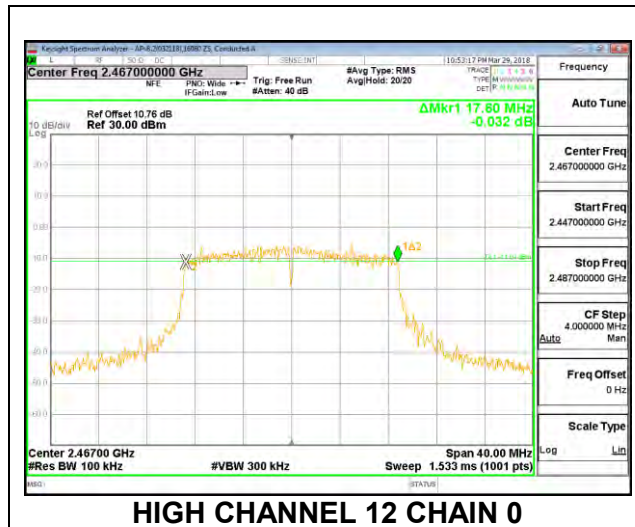

### HIGH CHANNEL 13

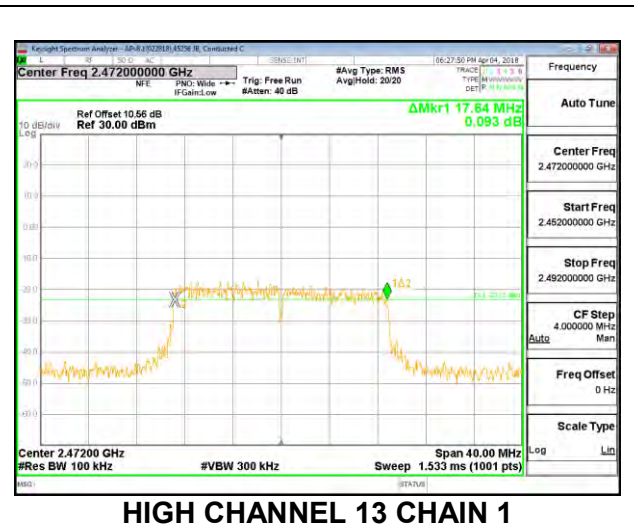
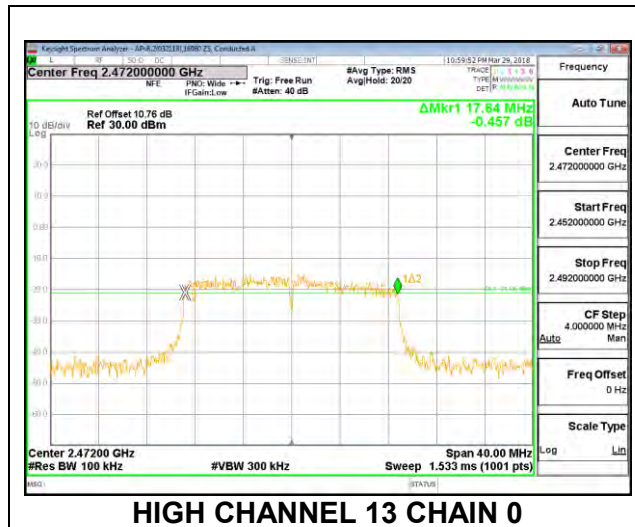

### 8.3. OUTPUT POWER

#### LIMITS

FCC §15.247 (b) (3)

For systems using digital modulation in the 902–928 MHz, 2400–2483.5 MHz, and 5725–5850 MHz bands: 1 Watt, based on the use of antennas with directional gains that do not exceed 6 dBi. If transmitting antennas of directional gain greater than 6 dBi are used, the conducted output power from the intentional radiator shall be reduced by the amount in dB that the directional gain of the antenna exceeds 6 dBi.

#### TEST PROCEDURE

The transmitter output is connected to a power meter.

The cable assembly insertion loss of 10.76 dB (including 10 dB pad and 0.76 dB cable) was entered as an offset in the power meter to allow for a gated peak reading of power.

#### DIRECTIONAL ANTENNA GAIN

Tx chains are uncorrelated for power and correlated for PSD due to the device supporting CDD in all MIMO modes. The directional gains are as follows:

Band (GHz)	Chain 0 Antenna Gain (dBi)	Chain 1 Antenna Gain (dBi)	Uncorrelated Chains Directional Gain (dBi)	Correlated Chains Directional Gain (dBi)
2.4	-1.20	-9.30	-3.58	-1.33

### 8.3.1. 802.11b MODE

#### RESULTS

<b>ID:</b>	16080 ZS	<b>Date:</b>	03/26/18
------------	----------	--------------	----------

#### Limits

Channel	Frequency (MHz)	Directional Gain (dBi)	FCC Power Limit (dBm)	IC Power Limit (dBm)	IC EIRP Limit (dBm)	Max Power (dBm)
CH1	2412	-3.58	30.00	30	36	30.00
CH6	2437	-3.58	30.00	30	36	30.00
CH11	2462	-3.58	30.00	30	36	30.00
CH12	2467	-3.58	30.00	30	36	30.00
CH13	2472	-3.58	30.00	30	36	30.00

#### Results

Channel	Frequency (MHz)	Chain 0 Meas Power (dBm)	Chain 1 Meas Power (dBm)	Total Corr'd Power (dBm)	Power Limit (dBm)	Margin (dB)
CH1	2412	10.31	8.47	12.50	30.00	-17.50
CH6	2437	10.26	8.34	12.42	30.00	-17.58
CH11	2462	10.18	8.11	12.28	30.00	-17.72
CH12	2467	9.57	8.41	12.04	30.00	-17.96
CH13	2472	9.50	8.65	12.11	30.00	-17.89

**Note:** the power readings above were measured with gated method, and the measurement was taken only during the ON time. No duty cycle correction was necessary.

### 8.3.2. 802.11g MODE

#### RESULTS

<b>ID:</b>	16080 ZS	<b>Date:</b>	03/26/18
------------	----------	--------------	----------

#### Limits

Channel	Frequency (MHz)	Directional Gain (dBi)	FCC Power Limit (dBm)	IC Power Limit (dBm)	IC EIRP Limit (dBm)	Max Power (dBm)
CH1	2412	-3.58	30.00	30	36	30.00
CH6	2437	-3.58	30.00	30	36	30.00
CH11	2462	-3.58	30.00	30	36	30.00
CH12	2467	-3.58	30.00	30	36	30.00
CH13	2472	-3.58	30.00	30	36	30.00

#### Results

Channel	Frequency (MHz)	Chain 0 Meas Power (dBm)	Chain 1 Meas Power (dBm)	Total Corr'd Power (dBm)	Power Limit (dBm)	Margin (dB)
CH1	2412	10.27	8.25	12.39	30.00	-17.61
CH6	2437	10.34	8.11	12.38	30.00	-17.62
CH11	2462	10.28	8.14	12.35	30.00	-17.65
CH12	2467	9.33	4.50	10.56	30.00	-19.44
CH13	2472	1.33	-2.52	2.83	30.00	-27.17

**Note:** the power readings above were measured with gated method, and the measurement was taken only during the ON time. No duty cycle correction was necessary.

### 8.3.3. 802.11n HT20 MODE

#### RESULTS

<b>ID:</b>	16080 ZS	<b>Date:</b>	03/26/18
------------	----------	--------------	----------

#### Limits

Channel	Frequency (MHz)	Directional Gain (dBi)	FCC Power Limit (dBm)	IC Power Limit (dBm)	IC EIRP Limit (dBm)	Max Power (dBm)
CH1	2412	-3.58	30.00	30	36	30.00
CH6	2437	-3.58	30.00	30	36	30.00
CH11	2462	-3.58	30.00	30	36	30.00
CH12	2467	-3.58	30.00	30	36	30.00
CH13	2472	-3.58	30.00	30	36	30.00

#### Results

Channel	Frequency (MHz)	Chain 0 Meas Power (dBm)	Chain 1 Meas Power (dBm)	Total Corr'd Power (dBm)	Power Limit (dBm)	Margin (dB)
CH1	2412	10.33	8.25	12.42	30.00	-17.58
CH6	2437	10.52	8.12	12.49	30.00	-17.51
CH11	2462	10.31	8.18	12.38	30.00	-17.62
CH12	2467	8.98	4.39	10.28	30.00	-19.72
CH13	2472	1.03	-3.62	2.31	30.00	-27.69

**Note:** the power readings above were measured with gated method, and the measurement was taken only during the ON time. No duty cycle correction was necessary.

## **8.4. POWER SPECTRAL DENSITY**

### **LIMITS**

FCC §15.247 (e)

The power spectral density conducted from the transmitter to the antenna shall not be greater than 8 dBm in any 3 kHz band during any time interval of continuous transmission.

### **RESULTS**

**8.4.1. 802.11b MODE**

<b>Duty Cycle CF (dB)</b>	0.00	<b>Included in Calculations of Corr'd PSD</b>
---------------------------	------	---

**PSD Results**

<b>Channel</b>	<b>Frequency (MHz)</b>	<b>Chain 0 Meas (dBm/ 30kHz)</b>	<b>Chain 1 Meas (dBm/ 30kHz)</b>	<b>Total Corr'd PSD (dBm/ 30kHz)</b>	<b>Limit (dBm/ 3kHz)</b>	<b>Margin (dB)</b>
Low 1	2412	-13.40	-13.71	-10.54	8.0	-18.5
Mid 6	2437	-12.72	-13.40	-10.04	8.0	-18.0
High 11	2462	-12.23	-12.70	-9.45	8.0	-17.4
High 12	2467	-11.98	-13.03	-9.46	8.0	-17.5
High 13	2472	-13.69	-13.39	-10.53	8.0	-18.5



### LOW CHANNEL 1

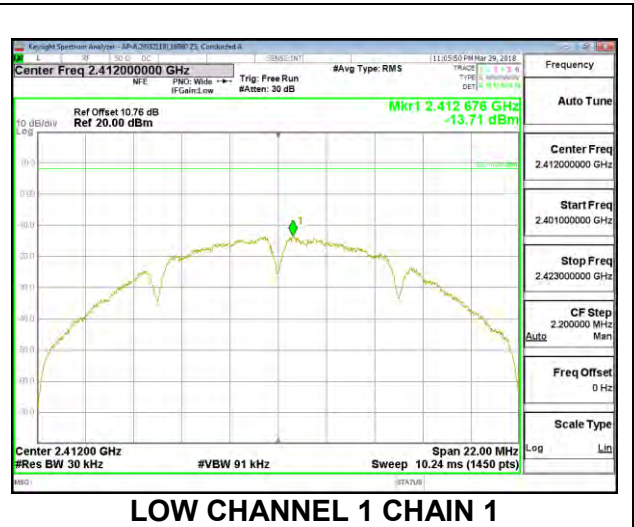
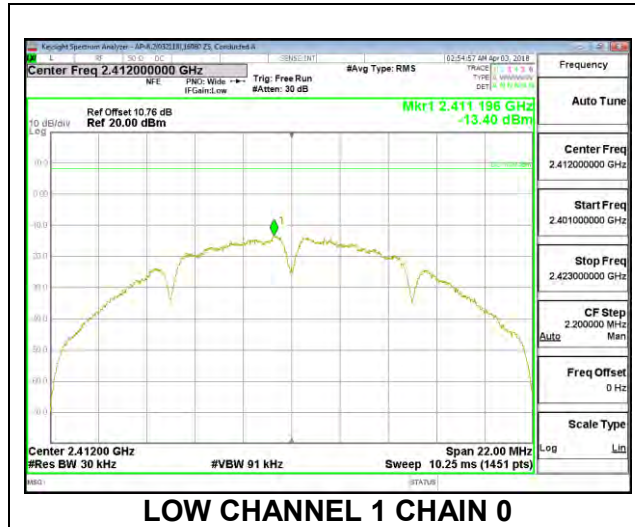

### MID CHANNEL 6

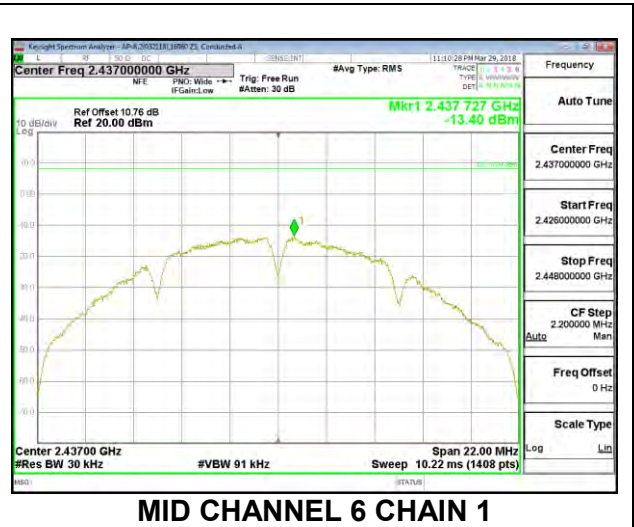
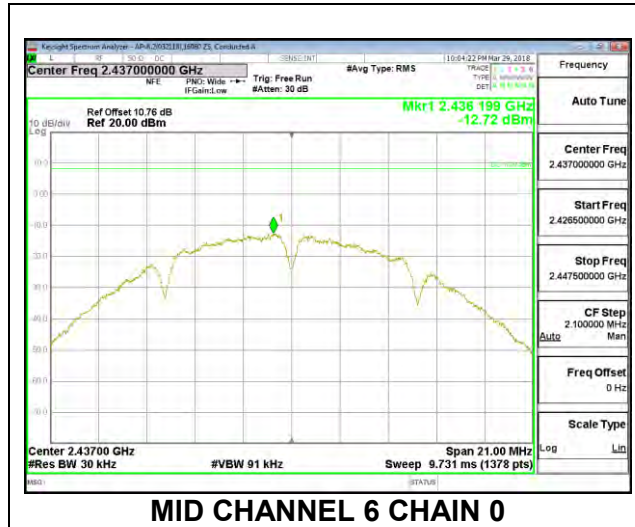

### HIGH CHANNEL 11

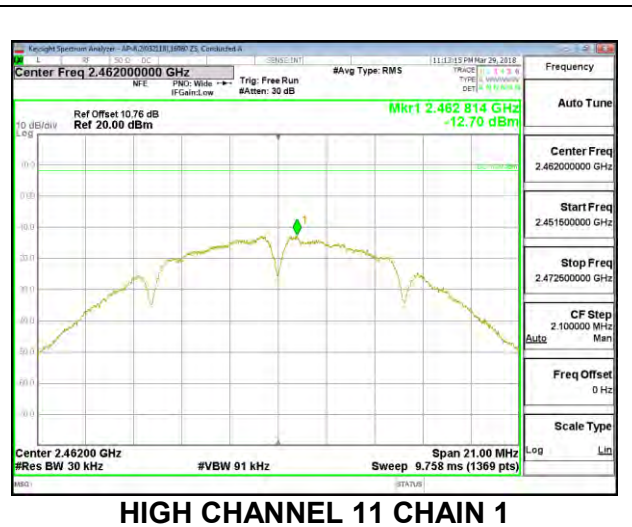
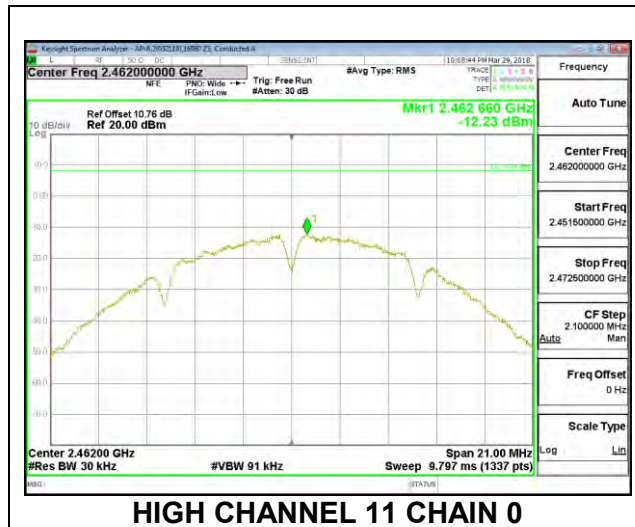

### HIGH CHANNEL 12

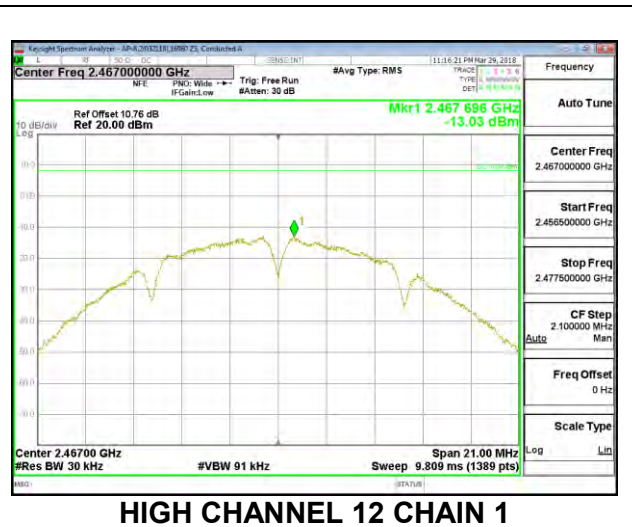
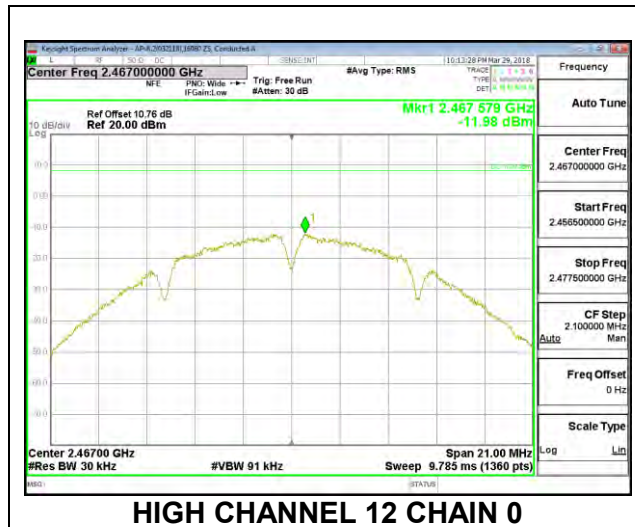

### HIGH CHANNEL 13

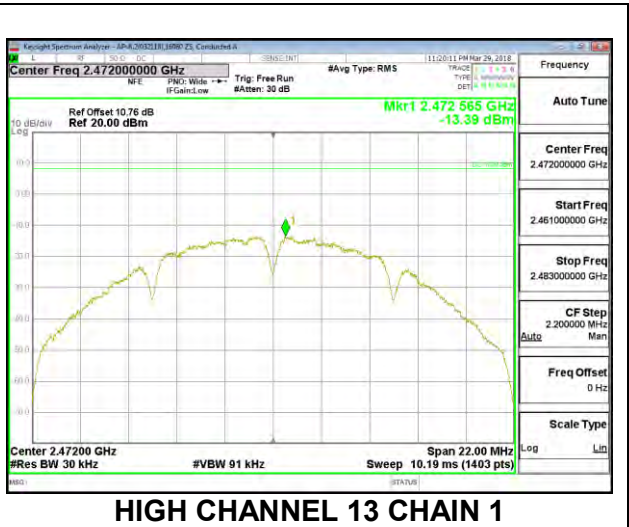
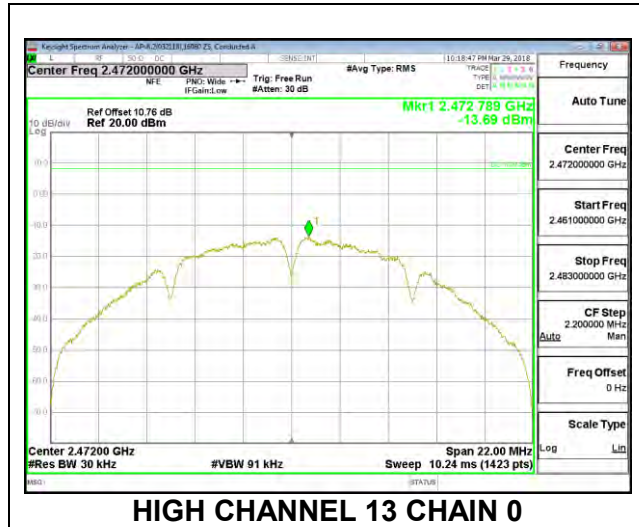

**8.4.2. 802.11g MODE**

<b>Duty Cycle CF (dB)</b>	0.00	<b>Included in Calculations of Corr'd PSD</b>
---------------------------	------	---

**PSD Results**

<b>Channel</b>	<b>Frequency (MHz)</b>	<b>Chain 0 Meas (dBm/ 30kHz)</b>	<b>Chain 1 Meas (dBm/ 30kHz)</b>	<b>Total Corr'd PSD (dBm/ 30kHz)</b>	<b>Limit (dBm/ 3kHz)</b>	<b>Margin (dB)</b>
Low 1	2412	-15.47	-15.47	-12.46	8.0	-20.5
Mid 6	2437	-14.83	-15.63	-12.20	8.0	-20.2
High 11	2462	-14.22	-15.10	-11.63	8.0	-19.6
High 12	2467	-15.45	-19.04	-13.87	8.0	-21.9
High 13	2472	-24.06	-26.55	-22.12	8.0	-30.1

### LOW CHANNEL 1

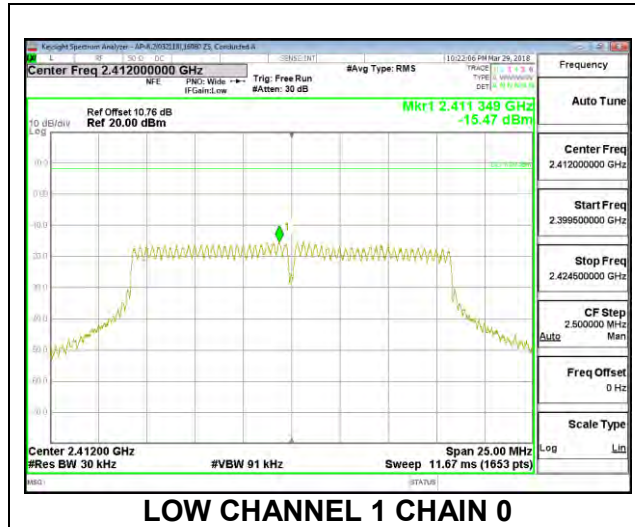

LOW CHANNEL 1 CHAIN 0

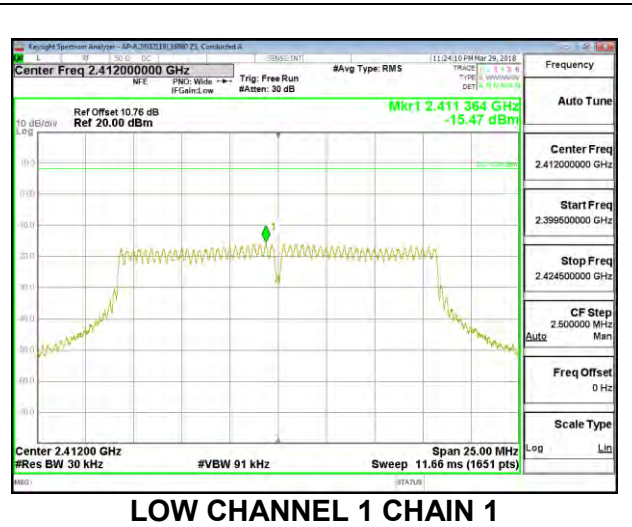

LOW CHANNEL 1 CHAIN 1

### MID CHANNEL 6

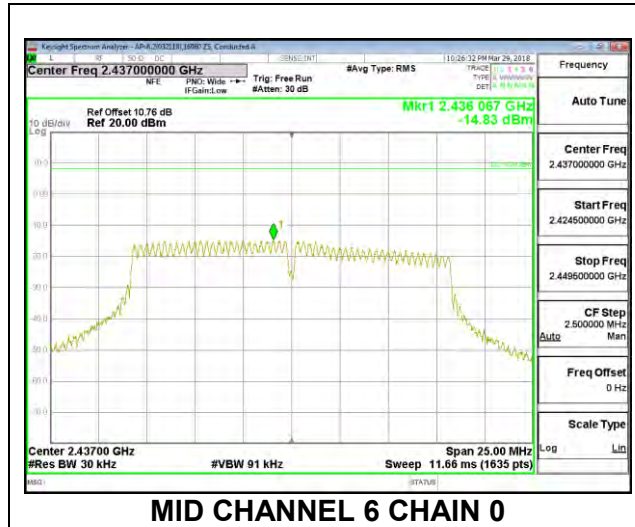

MID CHANNEL 6 CHAIN 0

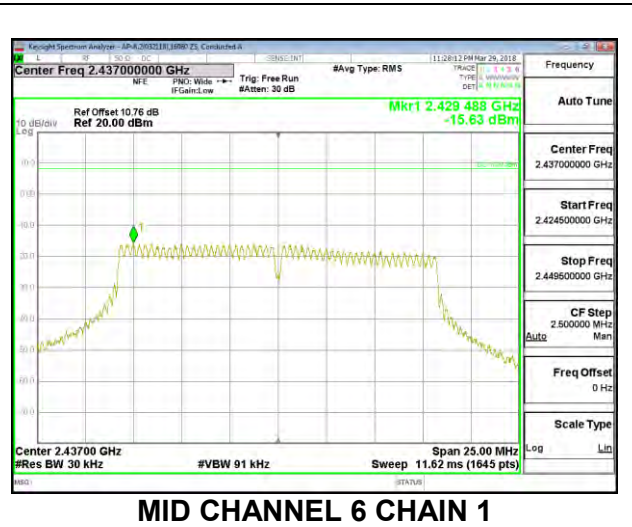

MID CHANNEL 6 CHAIN 1

### HIGH CHANNEL 11

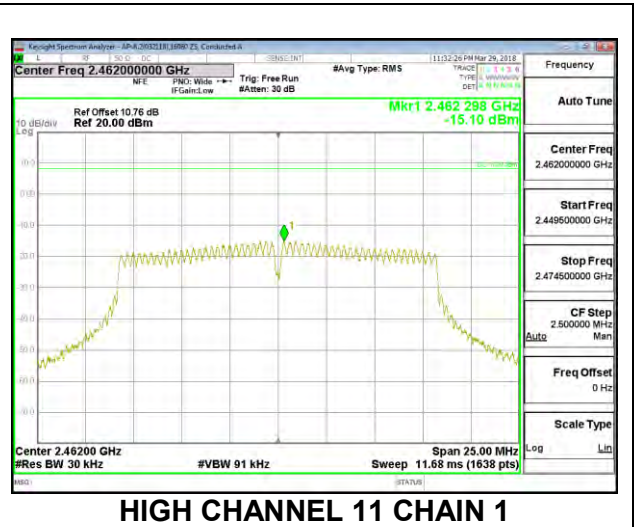
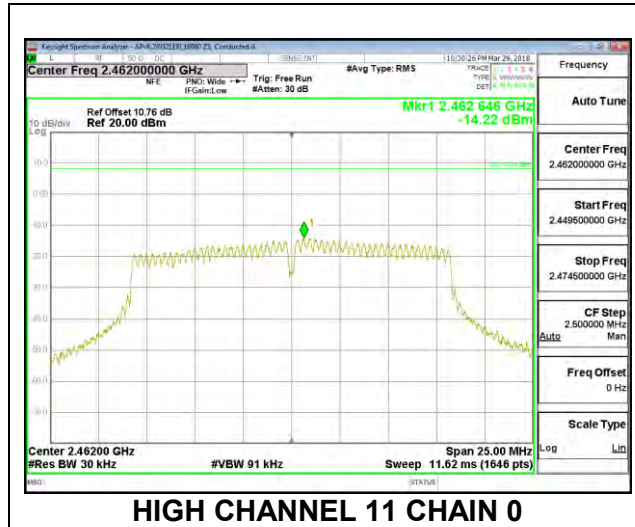

### HIGH CHANNEL 12

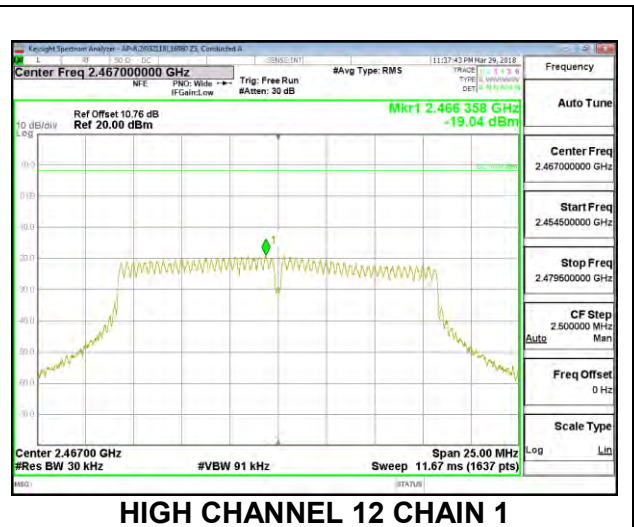
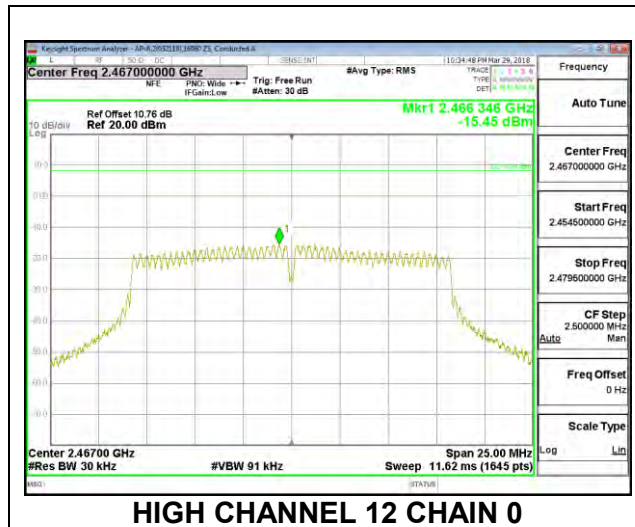

### HIGH CHANNEL 13

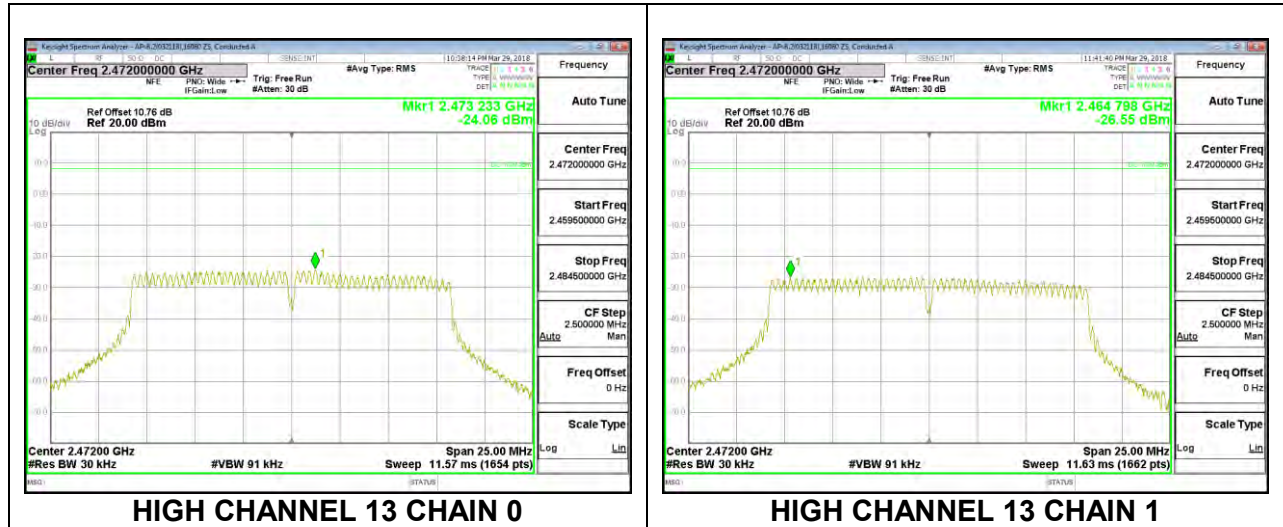

**8.4.3. 802.11n HT20 MODE**

<b>Duty Cycle CF (dB)</b>	0.11	<b>Included in Calculations of Corr'd PSD</b>
---------------------------	------	---

**PSD Results**

<b>Channel</b>	<b>Frequency (MHz)</b>	<b>Chain 0 Meas (dBm/ 30kHz)</b>	<b>Chain 1 Meas (dBm/ 30kHz)</b>	<b>Total Corr'd PSD (dBm/ 30kHz)</b>	<b>Limit (dBm/ 3kHz)</b>	<b>Margin (dB)</b>
Low 1	2412	-15.16	-15.91	-12.40	8.0	-20.4
Mid 6	2437	-14.77	-15.88	-12.17	8.0	-20.2
High 11	2462	-14.52	-15.40	-11.82	8.0	-19.8
High 12	2467	-15.31	-19.26	-13.73	8.0	-21.7
High 13	2472	-25.17	-27.25	-22.97	8.0	-31.0



### LOW CHANNEL 1

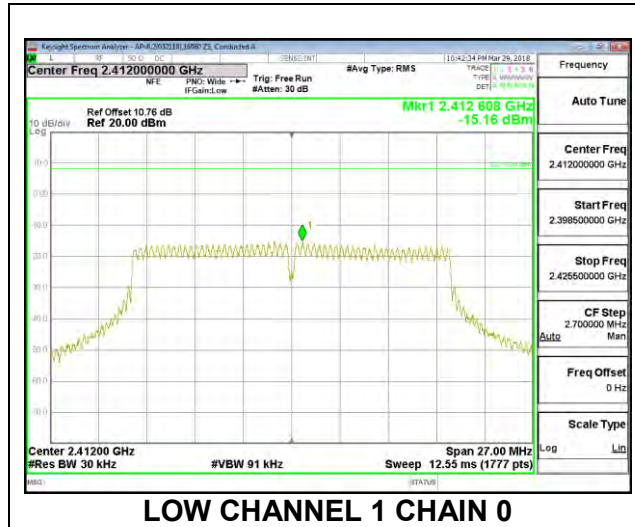

LOW CHANNEL 1 CHAIN 0

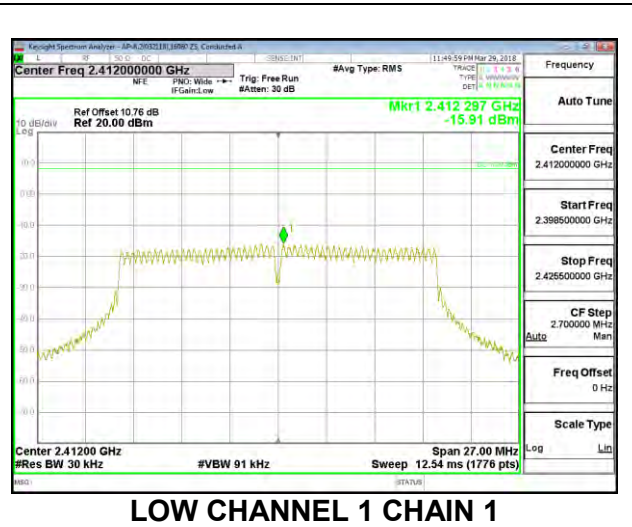

LOW CHANNEL 1 CHAIN 1

### MID CHANNEL 6

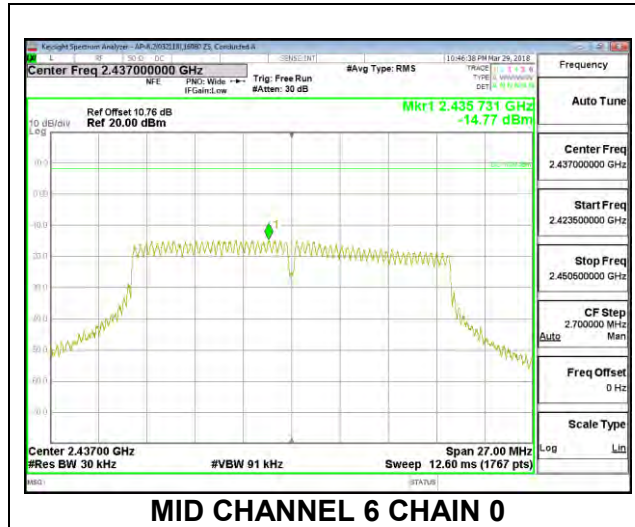

MID CHANNEL 6 CHAIN 0

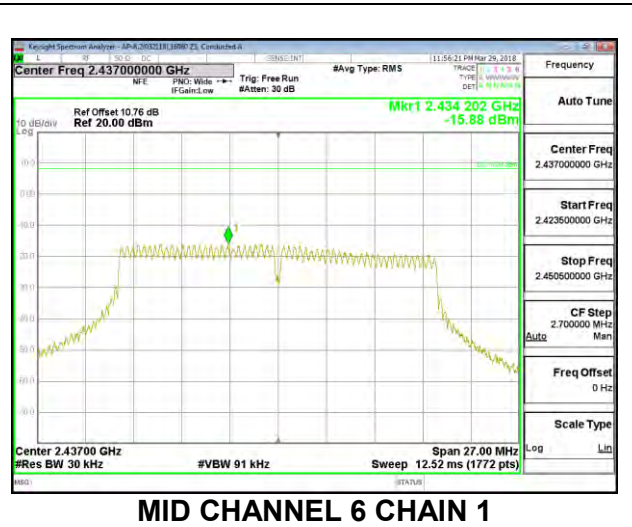

MID CHANNEL 6 CHAIN 1

### HIGH CHANNEL 11

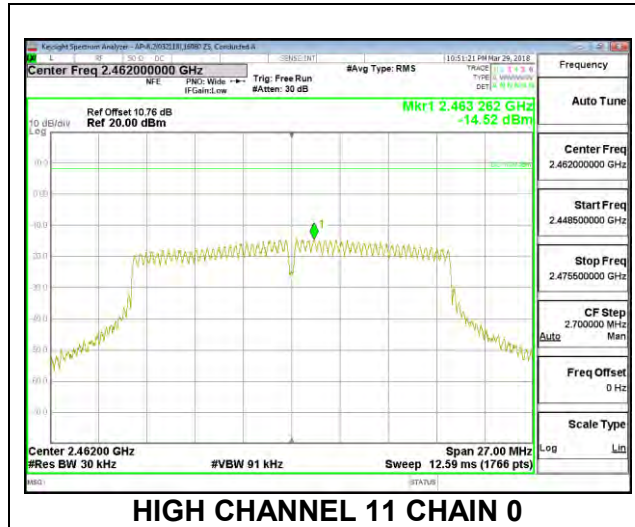

HIGH CHANNEL 11 CHAIN 0

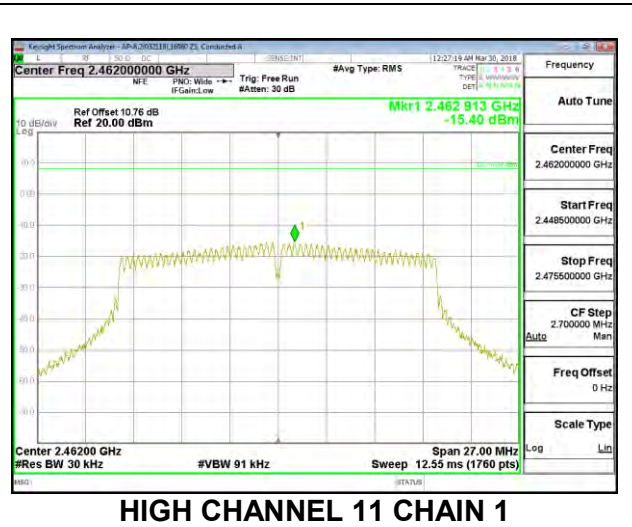

HIGH CHANNEL 11 CHAIN 1

### HIGH CHANNEL 12

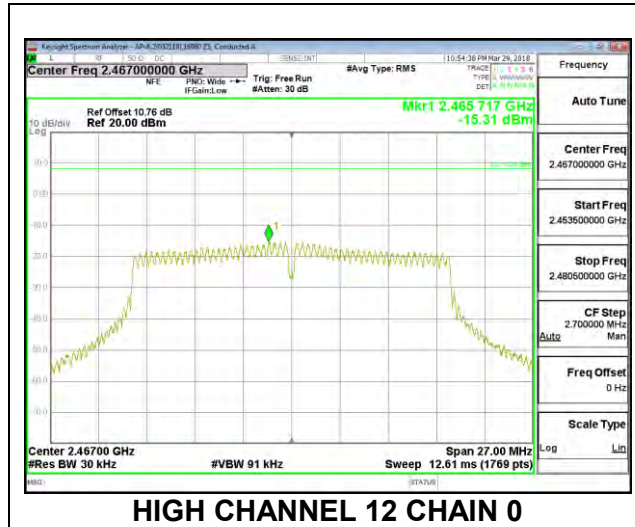

HIGH CHANNEL 12 CHAIN 0

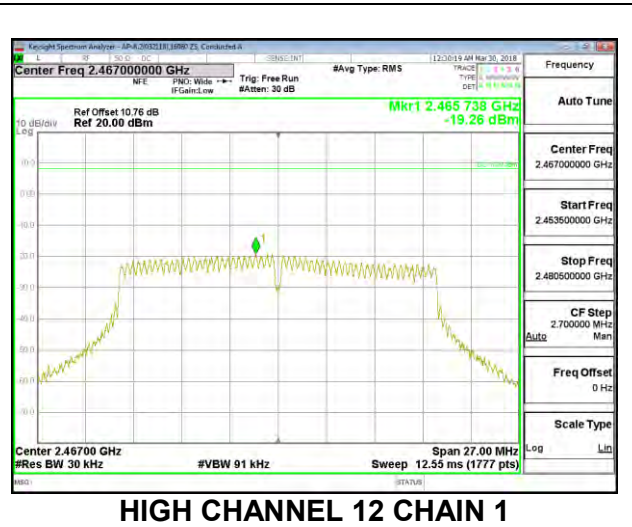

HIGH CHANNEL 12 CHAIN 1

### HIGH CHANNEL 13

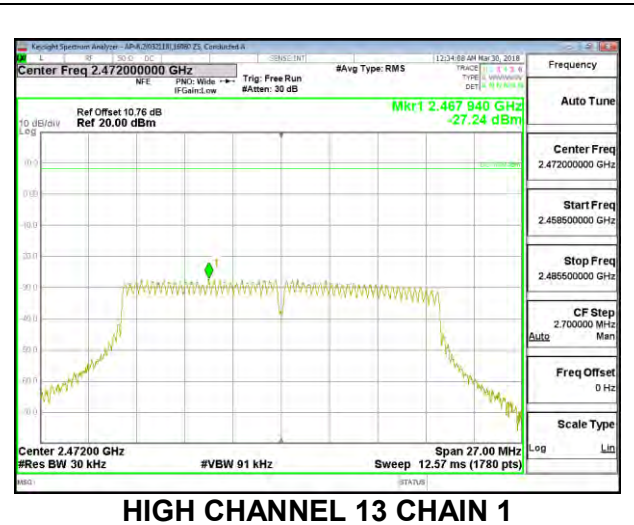
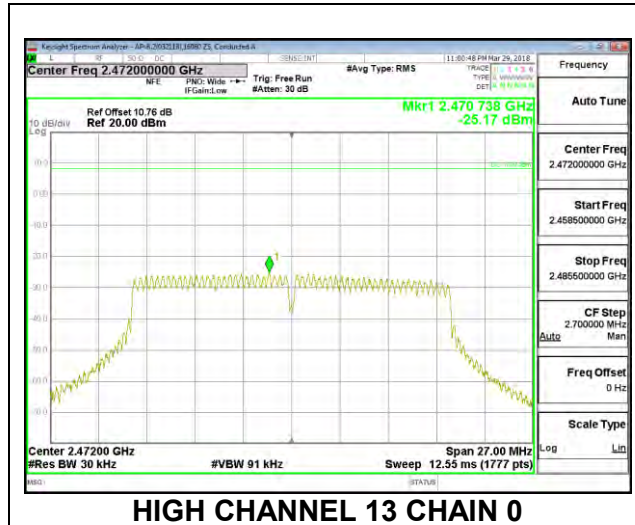

## **8.5. CONDUCTED SPURIOUS EMISSIONS**

### **LIMITS**

FCC §15.247 (d)

Output power was measured based on the use of peak measurement, therefore the required attenuation is 30 dB.

### **RESULTS**

### 8.5.1. 802.11b MODE

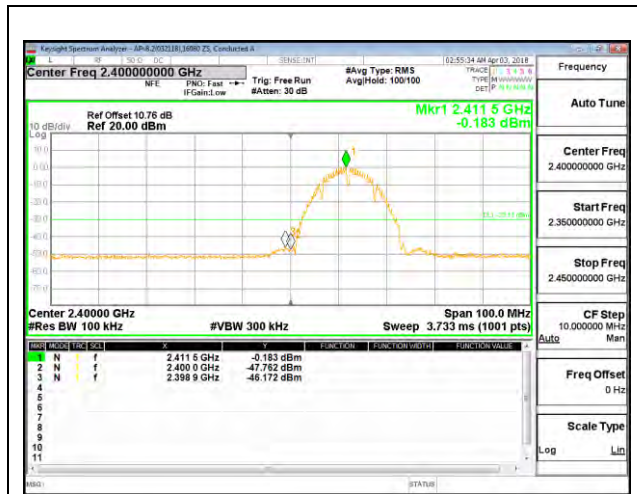

**LOW CHANNEL 1 BANDEDGE CHAIN 0**

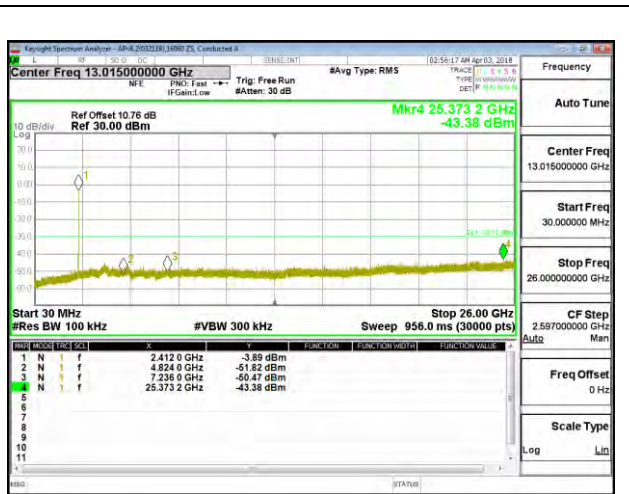

**OUT-OF-BAND LOW CHANNEL 1 CHAIN 0**

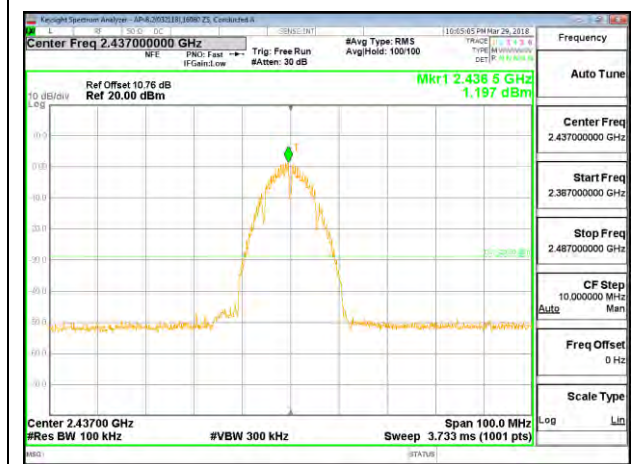

**IN-BAND REFERENCE LEVEL CHAIN 0**

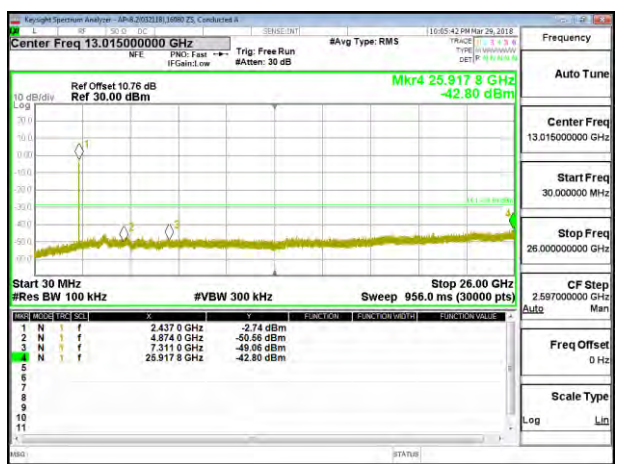

**OUT-OF-BAND MID CHANNEL CHAIN 0**

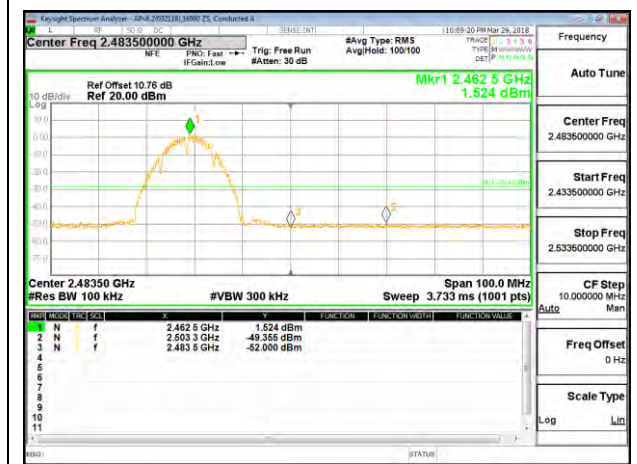

**HIGH CHANNEL 11 BANDEDGE CHAIN 0**

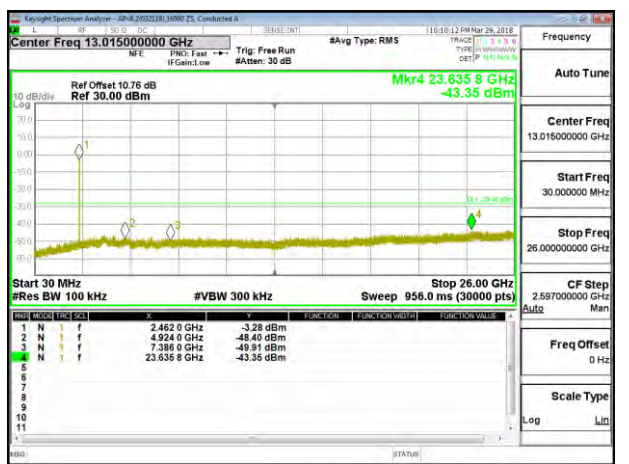

**OUT-OF-BAND HIGH CHANNEL 11 CHAIN 0**

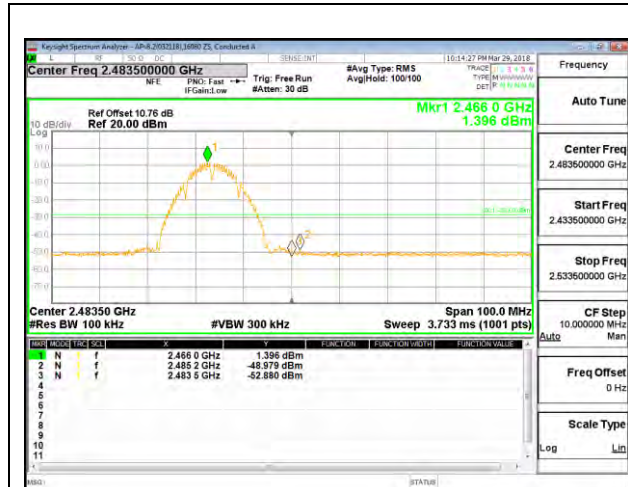

**HIGH CHANNEL 12 BANDEDGE CHAIN 0**



**OUT-OF-BAND HIGH CHANNEL 12 CHAIN 0**



**HIGH CHANNEL 13 BANDEDGE CHAIN 0**



**OUT-OF-BAND HIGH CHANNEL 13 CHAIN 0**

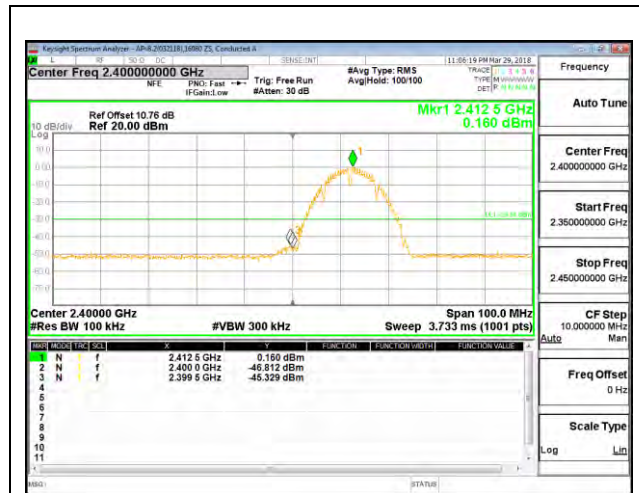

LOW CHANNEL 1 BANDEDGE CHAIN 1

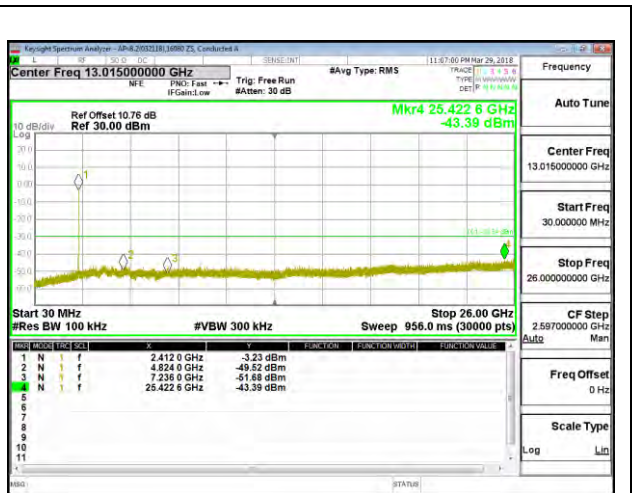

OUT-OF-BAND LOW CHANNEL 1 CHAIN 1

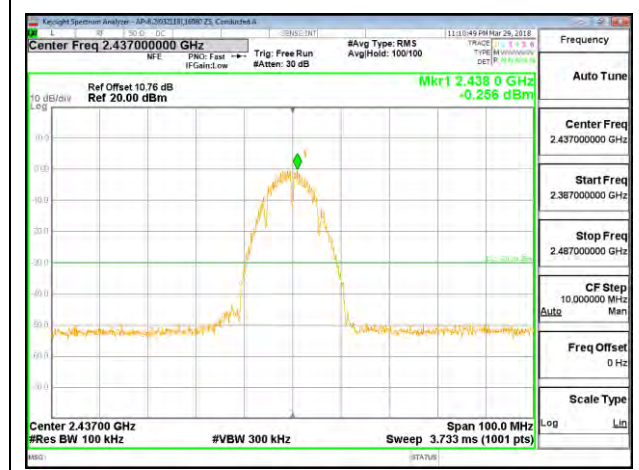

IN-BAND REFERENCE LEVEL CHAIN 1

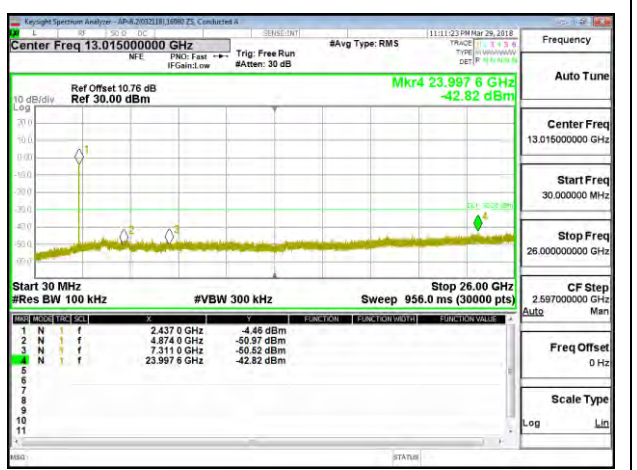

OUT-OF-BAND MID CHANNEL 1 CHAIN 1

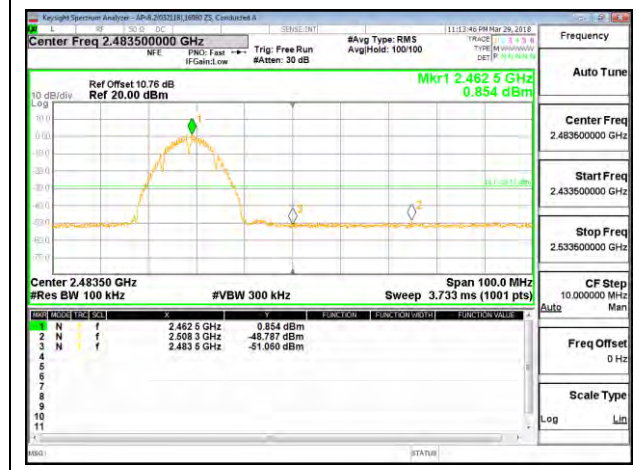

HIGH CHANNEL 11 BANDEDGE CHAIN 1



OUT-OF-BAND HIGH CHANNEL 11 CHAIN 1

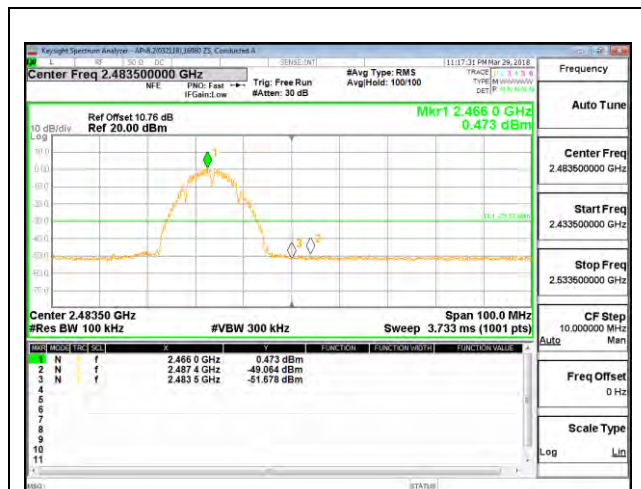

**HIGH CHANNEL 12 BANDEDGE CHAIN 1**

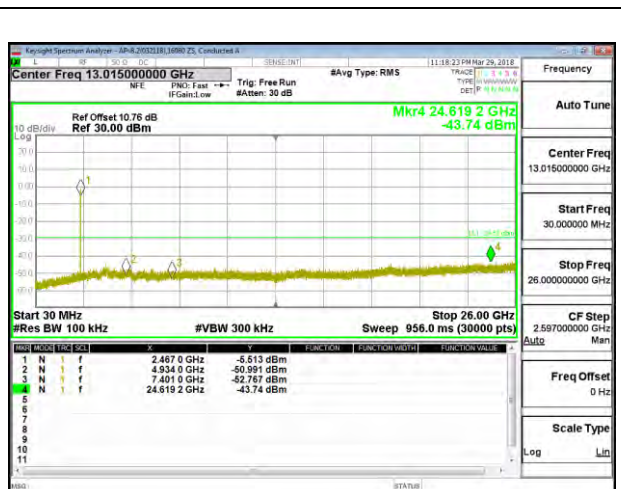

**OUT-OF-BAND HIGH CHANNEL 12 CHAIN 1**

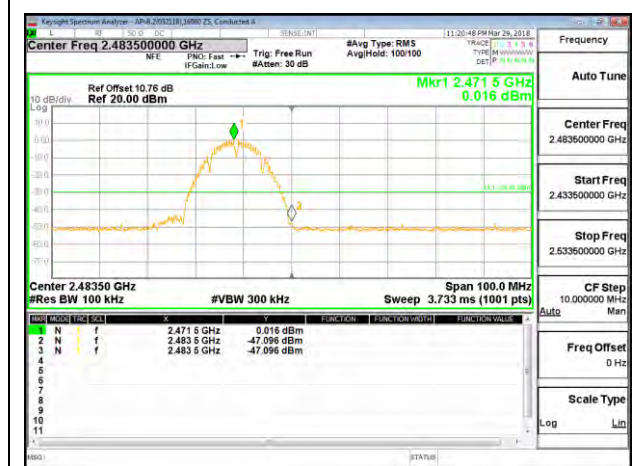

**HIGH CHANNEL 13 BANDEDGE CHAIN 1**

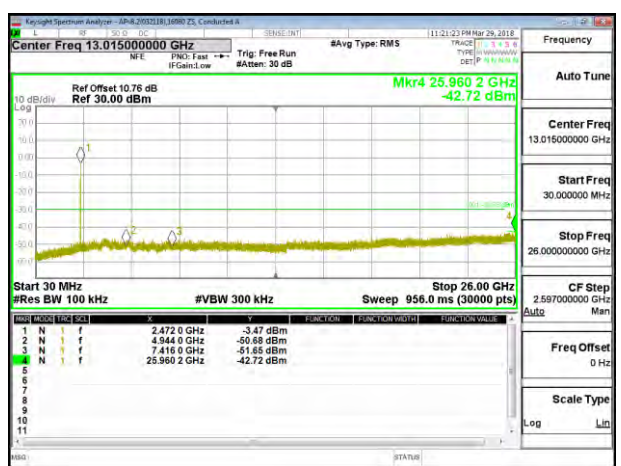

**OUT-OF-BAND HIGH CHANNEL 13 CHAIN 1**



### 8.5.2. 802.11g MODE

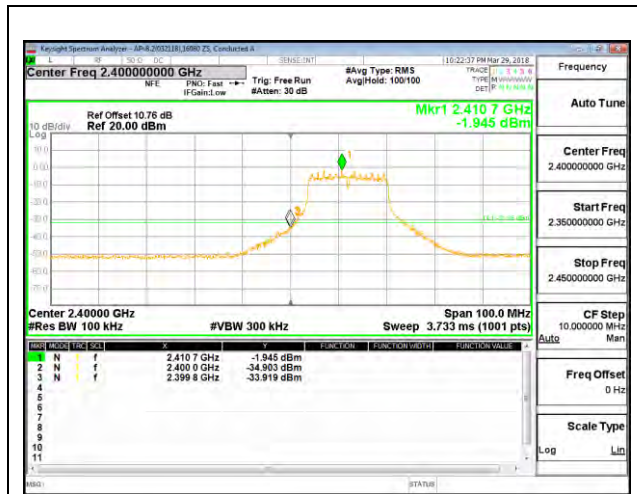

**LOW CHANNEL 1 BANDEDGE CHAIN 0**

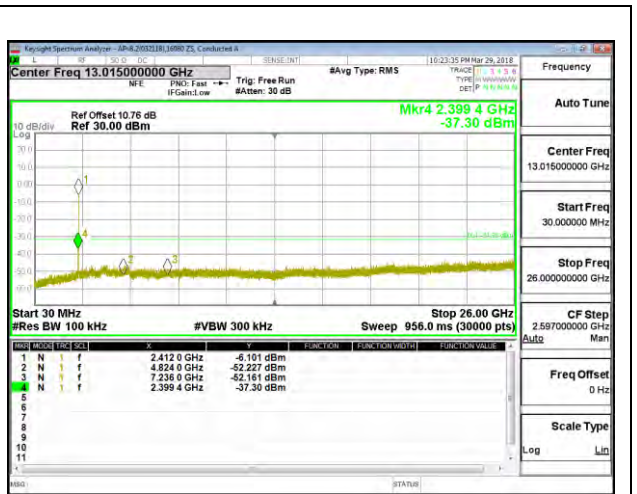

**OUT-OF-BAND LOW CHANNEL 1 CHAIN 0**



**IN-BAND REFERENCE LEVEL CHAIN 0**



**OUT-OF-BAND MID CHANNEL CHAIN 0**



**HIGH CHANNEL 11 BANDEDGE CHAIN 0**



**OUT-OF-BAND HIGH CHANNEL 11 CHAIN 0**



**HIGH CHANNEL 12 BANDEDGE CHAIN 0**



**OUT-OF-BAND HIGH CHANNEL 12 CHAIN 0**



**HIGH CHANNEL 13 BANDEDGE CHAIN 0**



**OUT-OF-BAND HIGH CHANNEL 13 CHAIN 0**