



CERTIFICATION TEST REPORT

Report Number. : 12132731-E2V1

Applicant : SONY MOBILE COMMUNICATIONS, INC.
4-12-3 HIGASHI-SHINAGAWA,
SHINAGAWA -KU, TOKYO, 140-0002, JAPAN

FCC ID : PY7-68553C

EUT Description : GSM/WCDMA/LTE Phone with BT, DTS/UNII a/b/g/n/ac &
NFC

Test Standard(s) : FCC 47 CFR PART 15 SUBPART C

Date Of Issue:

April 20, 2018

Prepared by:

UL Verification Services Inc.
47173 Benicia Street
Fremont, CA 94538, U.S.A.
TEL: (510) 771-1000
FAX: (510) 661-0888



REPORT REVISION HISTORY

Rev.	Issue Date	Revisions	Revised By
V1	04/20/18	Initial Issue	

TABLE OF CONTENTS

REPORT REVISION HISTORY	2
TABLE OF CONTENTS	3
1. ATTESTATION OF TEST RESULTS	5
2. TEST METHODOLOGY	6
3. FACILITIES AND ACCREDITATION	6
4. CALIBRATION AND UNCERTAINTY	7
4.1. <i>MEASURING INSTRUMENT CALIBRATION</i>	<i>7</i>
4.2. <i>SAMPLE CALCULATION</i>	<i>7</i>
4.3. <i>MEASUREMENT UNCERTAINTY.....</i>	<i>7</i>
5. EQUIPMENT UNDER TEST	8
5.1. <i>EUT DESCRIPTION</i>	<i>8</i>
5.2. <i>MAXIMUM OUTPUT POWER.....</i>	<i>8</i>
5.3. <i>DESCRIPTION OF AVAILABLE ANTENNAS</i>	<i>8</i>
5.4. <i>SOFTWARE AND FIRMWARE.....</i>	<i>8</i>
5.5. <i>WORST-CASE CONFIGURATION AND MODE.....</i>	<i>9</i>
5.6. <i>DESCRIPTION OF TEST SETUP.....</i>	<i>10</i>
6. TEST AND MEASUREMENT EQUIPMENT	13
7. MEASUREMENT METHODS	14
8. ANTENNA PORT TEST RESULTS	15
8.1. <i>ON TIME AND DUTY CYCLE.....</i>	<i>15</i>
8.2. <i>20 dB BANDWIDTH.....</i>	<i>16</i>
8.2.1. <i>BLUETOOTH BASIC DATA RATE GFSK MODULATION</i>	<i>17</i>
8.2.2. <i>BLUETOOTH ENCHANCED DATA RATE 8PSK MODULATION</i>	<i>18</i>
8.3. <i>HOPPING FREQUENCY SEPARATION</i>	<i>19</i>
8.3.1. <i>BLUETOOTH BASIC DATA RATE GFSK MODULATION</i>	<i>20</i>
8.3.2. <i>BLUETOOTH ENCHANCED DATA RATE 8PSK MODULATION</i>	<i>21</i>
8.4. <i>NUMBER OF HOPPING CHANNELS.....</i>	<i>22</i>
8.4.1. <i>BLUETOOTH BASIC DATA RATE GFSK MODULATION</i>	<i>23</i>
8.4.2. <i>BLUETOOTH ENCHANCED DATA RATE 8PSK MODULATION</i>	<i>25</i>
8.5. <i>AVERAGE TIME OF OCCUPANCY.....</i>	<i>27</i>
8.5.1. <i>BLUETOOTH BASIC DATA RATE GFSK MODULATION</i>	<i>28</i>
8.5.2. <i>BLUETOOTH ENCHANCED DATA RATE 8PSK MODULATION</i>	<i>30</i>

8.6.	<i>OUTPUT POWER</i>	32
8.6.1.	BLUETOOTH BASIC DATA RATE GFSK MODULATION	33
8.6.2.	BLUETOOTH ENCHANCED DATA RATE 8PSK MODULATION	34
8.7.	<i>AVERAGE POWER</i>	35
8.7.1.	BLUETOOTH BASIC DATA RATE GFSK MODULATION	36
8.7.2.	BLUETOOTH ENCHANCED DATA RATE 8PSK MODULATION	37
8.8.	<i>CONDUCTED SPURIOUS EMISSIONS</i>	38
8.8.1.	BLUETOOTH BASIC DATA RATE GFSK MODULATION	39
8.8.2.	BLUETOOTH ENCHANCED DATA RATE 8PSK MODULATION	41
9.	RADIATED TEST RESULTS	43
9.1.	<i>TRANSMITTER ABOVE 1 GHz</i>	44
9.1.1.	BLUETOOTH BASIC DATA RATE GFSK MODULATION	44
9.1.2.	BLUETOOTH ENCHANCED DATA RATE 8PSK MODULATION	54
9.2.	<i>SPURIOUS EMISSIONS BELOW 30 MHz (WORST-CASE CONFIGURATION)</i>	64
9.3.	<i>WORST-CASE BELOW 1 GHz</i>	65
9.4.	<i>WORST-CASE 18-26 GHz</i>	67
10.	AC POWER LINE CONDUCTED EMISSIONS	69
11.	SETUP PHOTOS	72

1. ATTESTATION OF TEST RESULTS

COMPANY NAME: SONY MOBILE COMMUNICATIONS, INC.
4-12-3 HIGASHI-SHINAGAWA,
SHINAGAWA -KU, TOKYO, 140-0002, JAPAN

EUT DESCRIPTION: GSM/WCDMA/LTE Phone with BT, DTS/UNII a/b/g/n/ac &
NFC

SERIAL NUMBER: CB512FH68Z (RADIATED)
CB512FHBUA (CONDUCTED)

DATE TESTED: March 22 –April 06, 2018

APPLICABLE STANDARDS	
STANDARD	TEST RESULTS
CFR 47 Part 15 Subpart C	Complies

UL Verification Services Inc. tested the above equipment in accordance with the requirements set forth in the above standards. All indications of Pass/Fail in this report are opinions expressed by UL Verification Services Inc. based on interpretations and/or observations of test results. Measurement Uncertainties were not taken into account and are published for informational purposes only. The test results show that the equipment tested is capable of demonstrating compliance with the requirements as documented in this report.

Note: The results documented in this report apply only to the tested sample, under the conditions and modes of operation as described herein. This document may not be altered or revised in any way unless done so by UL Verification Services Inc. and all revisions are duly noted in the revisions section. Any alteration of this document not carried out by UL Verification Services Inc. will constitute fraud and shall nullify the document. This report must not be used by the client to claim product certification, approval, or endorsement by NVLAP, NIST, any agency of the Federal Government, or any agency of the U.S. government.

Approved & Released For
UL Verification Services Inc. By:

Reviewed By:



Dan Corona
CONSUMER TECHNOLOGY DIVISION
Operations Leader
UL Verification Services Inc.

Kiya Kedida
CONSUMER TECHNOLOGY DIVISION
Project Engineer
UL Verification Services Inc.

2. TEST METHODOLOGY

The tests documented in this report were performed in accordance with FCC CFR 47 Part 2, FCC CFR 47 Part 15, ANSI C63.10-2013.

3. FACILITIES AND ACCREDITATION

The test sites and measurement facilities used to collect data are located at 47173 and 47266 Benicia Street, Fremont, California, USA. Line conducted emissions are measured only at the 47173 address. The following table identifies which facilities were utilized for radiated emission measurements documented in this report. Specific facilities are also identified in the test results sections.

47173 Benicia Street	47266 Benicia Street
<input checked="" type="checkbox"/> Chamber A (ISED:2324B-1)	<input type="checkbox"/> Chamber D (ISED:22541-1)
<input type="checkbox"/> Chamber B (ISED:2324B-2)	<input type="checkbox"/> Chamber E (ISED:22541-2)
<input checked="" type="checkbox"/> Chamber C (ISED:2324B-3)	<input type="checkbox"/> Chamber F (ISED:22541-3)
	<input type="checkbox"/> Chamber G (ISED:22541-4)
	<input type="checkbox"/> Chamber H (ISED:22541-5)

The above test sites and facilities are covered under FCC Test Firm Registration # 208313. Chambers A through C are covered under ISED company address code 2324B with site numbers 2324B -1 through 2324B-3, respectively. Chambers D through H are covered under ISED company address code 22541 with site numbers 22541 -1 through 22541-5, respectively.

UL Verification Services Inc. is accredited by NVLAP, Laboratory Code 200065-0. The full scope of accreditation can be viewed at <http://nist.gov/standards/scopes/2000650.htm>.

4. CALIBRATION AND UNCERTAINTY

4.1. MEASURING INSTRUMENT CALIBRATION

The measuring equipment utilized to perform the tests documented in this report has been calibrated in accordance with the manufacturer's recommendations, and is traceable to recognized national standards.

4.2. SAMPLE CALCULATION

Where relevant, the following sample calculation is provided:

$$\begin{aligned} \text{Field Strength (dBuV/m)} &= \text{Measured Voltage (dBuV)} + \text{Antenna Factor (dB/m)} + \\ &\text{Cable Loss (dB)} - \text{Preamp Gain (dB)} \\ 36.5 \text{ dBuV} + 18.7 \text{ dB/m} + 0.6 \text{ dB} - 26.9 \text{ dB} &= 28.9 \text{ dBuV/m} \end{aligned}$$

4.3. MEASUREMENT UNCERTAINTY

Where relevant, the following measurement uncertainty levels have been estimated for tests performed on the apparatus:

PARAMETER	UNCERTAINTY
Worst Case Conducted Disturbance, 9KHz to 0.15 MHz	3.84 dB
Worst Case Conducted Disturbance, 0.15 to 30 MHz	3.65 dB
Worst Case Radiated Disturbance, 9KHz to 30 MHz	3.15 dB
Worst Case Radiated Disturbance, 30 to 1000 MHz	5.36 dB
Worst Case Radiated Disturbance, 1000 to 18000 MHz	4.32 dB
Worst Case Radiated Disturbance, 18000 to 26000 MHz	4.45 dB
Worst Case Radiated Disturbance, 26000 to 40000 MHz	5.24 dB

Uncertainty figures are valid to a confidence level of 95%.

5. EQUIPMENT UNDER TEST

5.1. EUT DESCRIPTION

The EUT is a GSM/WCDMA/LTE Phone with BT, DTS/UNII a/b/g/n/ac & NFC.

5.2. MAXIMUM OUTPUT POWER

The transmitter has a maximum peak conducted output power as follows:

Frequency Range (MHz)	Mode	Output Power (dBm)	Output Power (mW)
2402 - 2480	Basic GFSK	10.66	11.64
2402 - 2480	Enhanced 8PSK	10.20	10.47

Note: GFSK, DQPSK, 8PSK average Power are all investigated, The GFSK & 8PSK Power are the worst case. Testing is based on these modes to showing compliance. For average power data please refer to section 8.7.

5.3. DESCRIPTION OF AVAILABLE ANTENNAS

The radio utilizes Loop Type antenna, with the following maximum gain:

Frequency Band (GHz)	Antenna Gain (dBi)
2402-2480	-1.20

5.4. SOFTWARE AND FIRMWARE

The firmware installed in the EUT during testing was s_atp_XXX_0_00403_A_9.
The test utility software used during testing was Tera Term Ver 4.79.

5.5. WORST-CASE CONFIGURATION AND MODE

Radiated emissions below 30MHz, below 1GHz and above 18GHz, and AC power line conducted emission were performed with the EUT set to transmit at the channel with highest output power as worst-case scenario.

Band edge and radiated emissions between 1GHz and 18GHz were performed with the EUT set to transmit at the highest power on low, middle and high channels.

The fundamental of the EUT was investigated in three orthogonal orientations X, Y, & Z, and it was determined that X-Axis with AC/DC Adapter was worst-case orientation; therefore, all final radiated testing was performed with the EUT in X-Axis with AC/DC Adapter orientation.

Worst-case data rates as provided by the client were:

GFSK mode: DH5
8PSK mode: 3-DH5

5.6. DESCRIPTION OF TEST SETUP

SUPPORT EQUIPMENT

Support Equipment List				
Description	Manufacturer	Model	Serial Number	FCC ID
Laptop	Lenovo	20B7S0A200	PC015REW	NA
AC Adapter	SONY	UCH12	4016W40310044	NA
DC Power Supply	Ametek	XT 15-4	T463	N/A

I/O CABLES (CONDUCTED TEST)

I/O Cable List						
Cable No	Port	# of identical ports	Connector Type	Cable Type	Cable Length (m)	Remarks
1	Antenna	1	RF	Shielded	0.2	To spectrum Analyzer
2	USB	1	USB	Shielded	1	N/A
3	DC	1	DC	Shielded	0.3	N/A

I/O CABLES (RADIATED AND CONDUCTED EMISSIONS)

I/O Cable List						
Cable No	Port	# of identical ports	Connector Type	Cable Type	Cable Length (m)	Remarks
1	USB	1	USB	Shielded	3	N/A

TEST SETUP

CONDUCTED TEST SETUP DIAGRAM

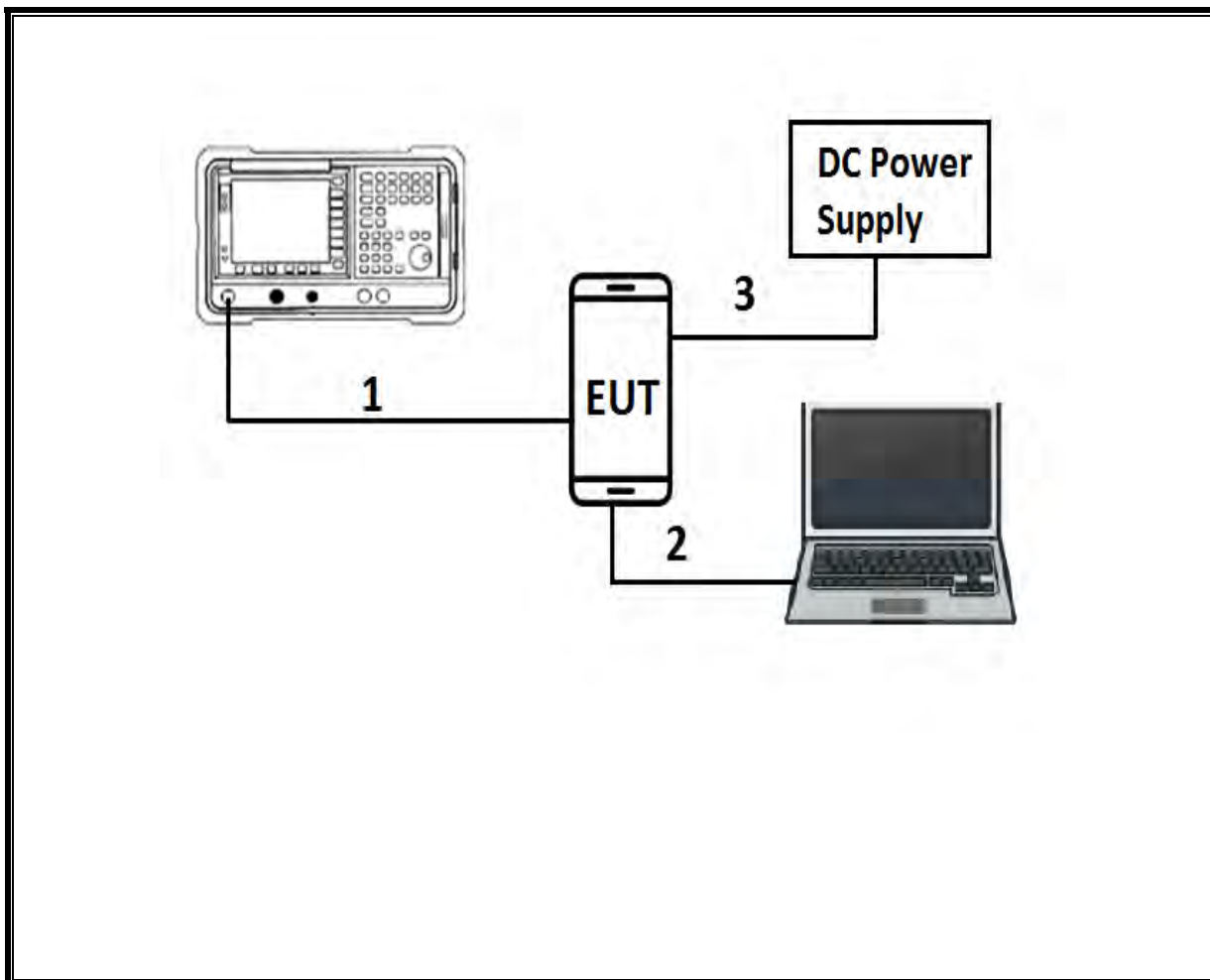

TEST SETUP

RADIATED AND AC LINE CONDUCTED EMISSIONS SETUP DIAGRAM

|

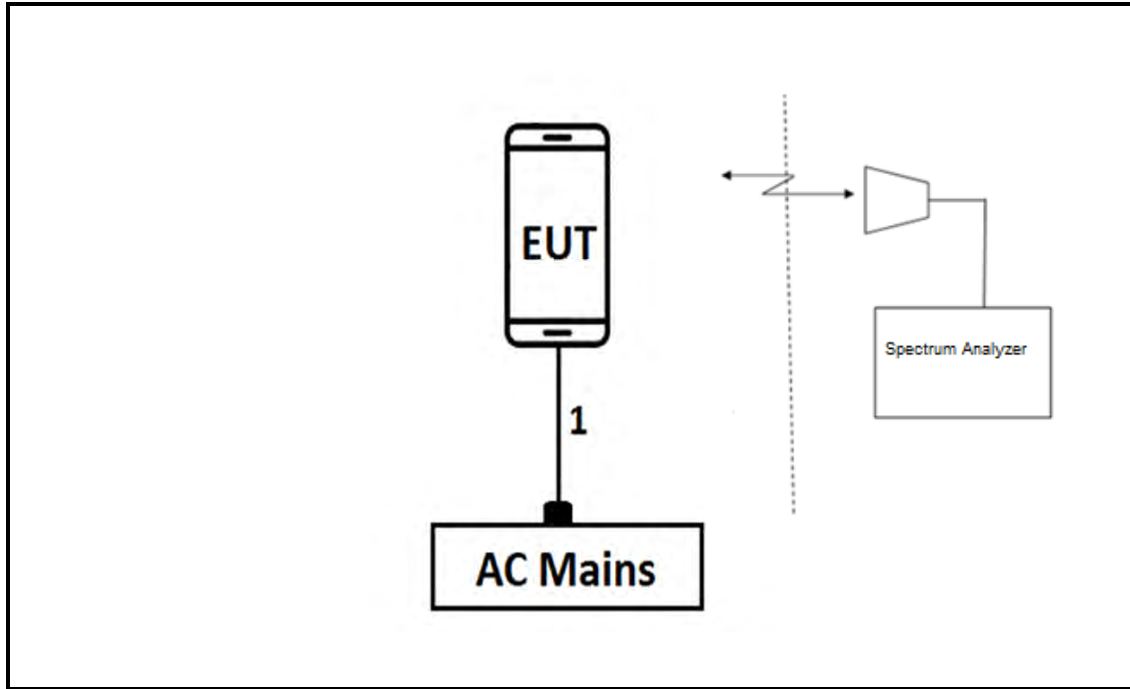

6. TEST AND MEASUREMENT EQUIPMENT

The following test and measurement equipment was utilized for the tests documented in this report:

TEST EQUIPMENT LIST				
Description	Manufacturer	Model	Asset	Cal Due
Amplifier, 10KHz to 1GHz, 32dB	Agilent (Keysight) Technologies	8447D	T15	08/14/2018
Amplifier, 1 - 18GHz	MITEQ	AFS42-00101800-25-S-42	T931	09/20/2018
Amplifier, 1 to 18GHz	Miteq	AFS42-00101800-25-S-42	T1165	11/25/2018
RF Preamplifier, 1 - 26GHz	Agilent	8449B	T404	07/23/2018
Antenna, Active Loop 9kHz-30MHz	Com-Power Corp.	AL-130R	T1866	10/10/2018
Antenna, Broadband Hybrid, 30MHz to 2000MHz	Sunol Sciences Corp.	JB3	T130	06/15/2018
Antenna, Horn 1-18GHz	ETS-Lindgren	3117	T120	06/26/2018
Antenna, Horn 1-18GHz	ETS-Lindgren	3117	T862	06/09/2018
Antenna Horn, 18 to 26GHz	ARA	MWH-1826	T89	01/18/2019
Power Meter, P-series single channel	Keysight	N1912A	T1245	05/12/2018
Power Sensor	Keysight	N1921A	T413	06/22/2018
Spectrum Analyzer, PXA, 3Hz to 44GHz	Agilent (Keysight) Technologies	N9030A	T1466	04/11/2018
Spectrum Analyzer, PXA, 3Hz to 44GHz	Agilent (Keysight) Technologies	N9030A	T1454	01/08/2019
Spectrum Analyzer, PXA, 3Hz to 44GHz	Agilent (Keysight) Technologies	N9030A	T1113	12/21/2018
Spectrum Analyzer, PXA, 3Hz to 44GHz	Agilent (Keysight) Technologies	N9030A	T1450	02/05/2019
AC Line Conducted				
EMI Test Receiver 9Khz-7GHz	Rohde & Schwarz	ESC17	T1124	11/07/2018
LISN for Conducted Emissions CISPR-16	Fischer	50/250-25-2-01	T1310	06/15/2018
Power Cable, Line Conducted Emissions	UL	PG1	T861	08/31/2018
UL AUTOMATION SOFTWARE				
Radiated Software	UL	UL EMC	Ver 9.5, Dec 01, 2016	
Antenna Port Software	UL	UL EMC	Ver 8.2, Feb 28, 2018	
AC Line Conducted Software	UL	UL EMC	Ver 9.5, May 26, 2015	

NOTES:

1. Equipment listed above that calibrated during the testing period was set for test after the calibration.
2. Equipment listed above that has a calibration due date during the testing period, the testing is completed before equipment expiration date.

7. MEASUREMENT METHODS

On Time and Duty Cycle: ANSI C63.10-2013 Section 11.6

Occupied BW (20dB): ANSI C63.10-2013 Section 6.9.2

Carrier Frequency Separation: ANSI C63.10-2013 Section 7.8.2

Number of Hopping Frequencies: ANSI C63.10-2013 Section 7.8.3

Time of Occupancy (Dwell Time): ANSI C63.10-2013 Section 7.8.4

Peak Output Power: ANSI C63.10-2013 Section 7.8.5

Conducted Spurious Emissions: ANSI C63.10-2013 Section 7.8.8

Conducted Band-Edge: ANSI C63.10-2013 Section 6.10.4

Radiated Spurious Emissions 30-1000MHz: ANSI C63.10-2013 Section 6.3 and 6.5

Radiated Spurious Emissions above 1GHz: ANSI C63.10-2013 Section 6.3 and 6.6

Radiated Band-edge: ANSI C63.10-2013 Section 6.10.5

AC Power-line conducted emissions: ANSI C63.10-2013, Section 6.2.

8. ANTENNA PORT TEST RESULTS

8.1. ON TIME AND DUTY CYCLE

LIMITS

None; for reporting purposes only.

ON TIME AND DUTY CYCLE RESULTS

Mode	ON Time B (msec)	Period (msec)	Duty Cycle x (linear)	Duty Cycle (%)	Duty Cycle Correction Factor (dB)	1/T Minimum VBW (kHz)
GFSK	2.89	3.75	0.770	77.0%	1.14	0.347
8PSK	2.89	3.76	0.768	76.8%	1.15	0.347

DUTY CYCLE PLOTS

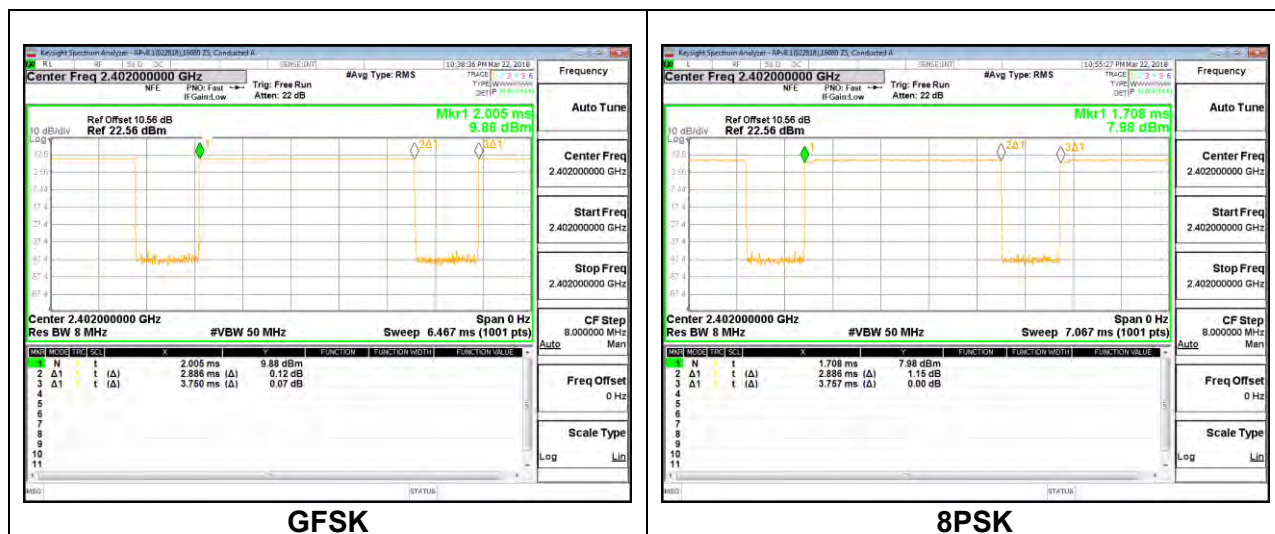

8.2. 20 dB BANDWIDTH

LIMITS

None; for reporting purposes only.

TEST PROCEDURE

The transmitter output is connected to a spectrum analyzer. The RBW is set to $\geq 1\%$ of the 20 dB bandwidth. The VBW is set to \geq RBW. The sweep time is coupled.

RESULTS

8.2.1. BLUETOOTH BASIC DATA RATE GFSK MODULATION

Channel	Frequency (MHz)	20dB Bandwidth (MHz)
Low	2402	0.886
Mid	2441	0.886
High	2480	0.887

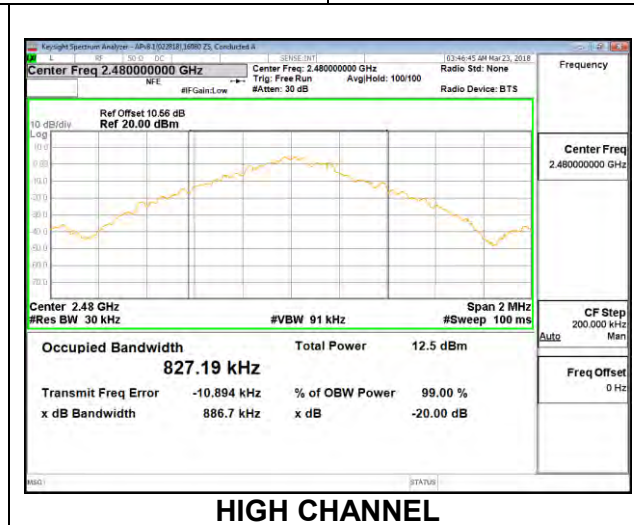
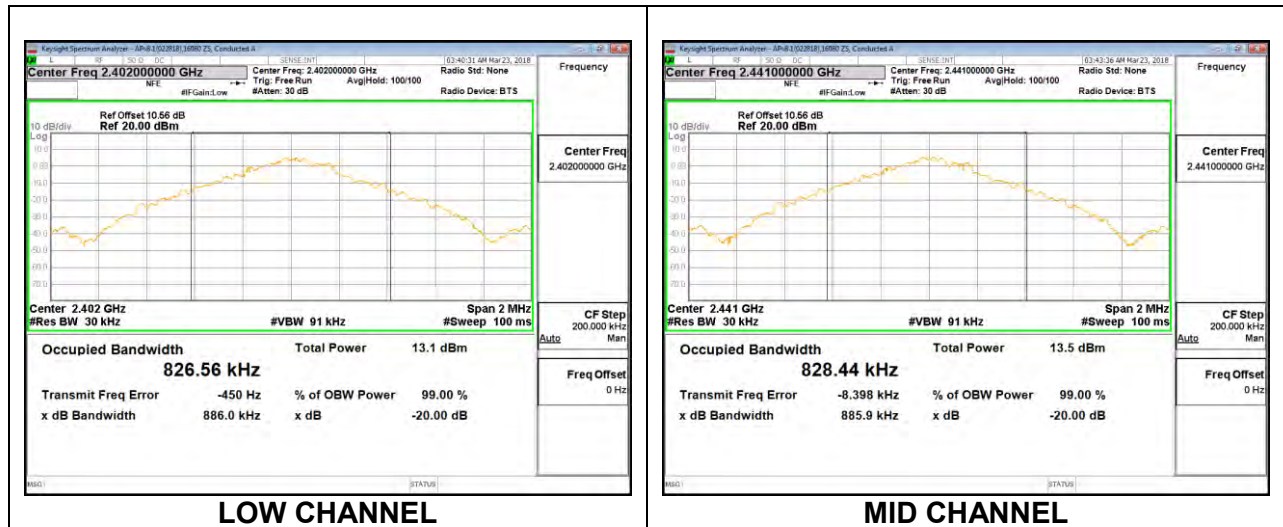

8.2.2. BLUETOOTH ENCHANCED DATA RATE 8PSK MODULATION

Channel	Frequency (MHz)	20dB Bandwidth (MHz)
Low	2402	1.270
Mid	2441	1.267
High	2480	1.266



8.3. HOPPING FREQUENCY SEPARATION

LIMITS

FCC §15.247 (a) (1)

Frequency hopping systems shall have hopping channel carrier frequencies separated by a minimum of 25 kHz or the 20 dB bandwidth of the hopping channel, whichever is greater.

Alternatively, frequency hopping systems operating in the 2400-2483.5 MHz band may have hopping channel carrier frequencies that are separated by 25 kHz or two-thirds of the 20 dB bandwidth of the hopping channel, whichever is greater, provided the systems operate with an output power no greater than 125 mW.

TEST PROCEDURE

The transmitter output is connected to a spectrum analyzer. The RBW is set to 300 kHz and the VBW is set to 910 kHz. The sweep time is coupled.

RESULTS

8.3.1. BLUETOOTH BASIC DATA RATE GFSK MODULATION

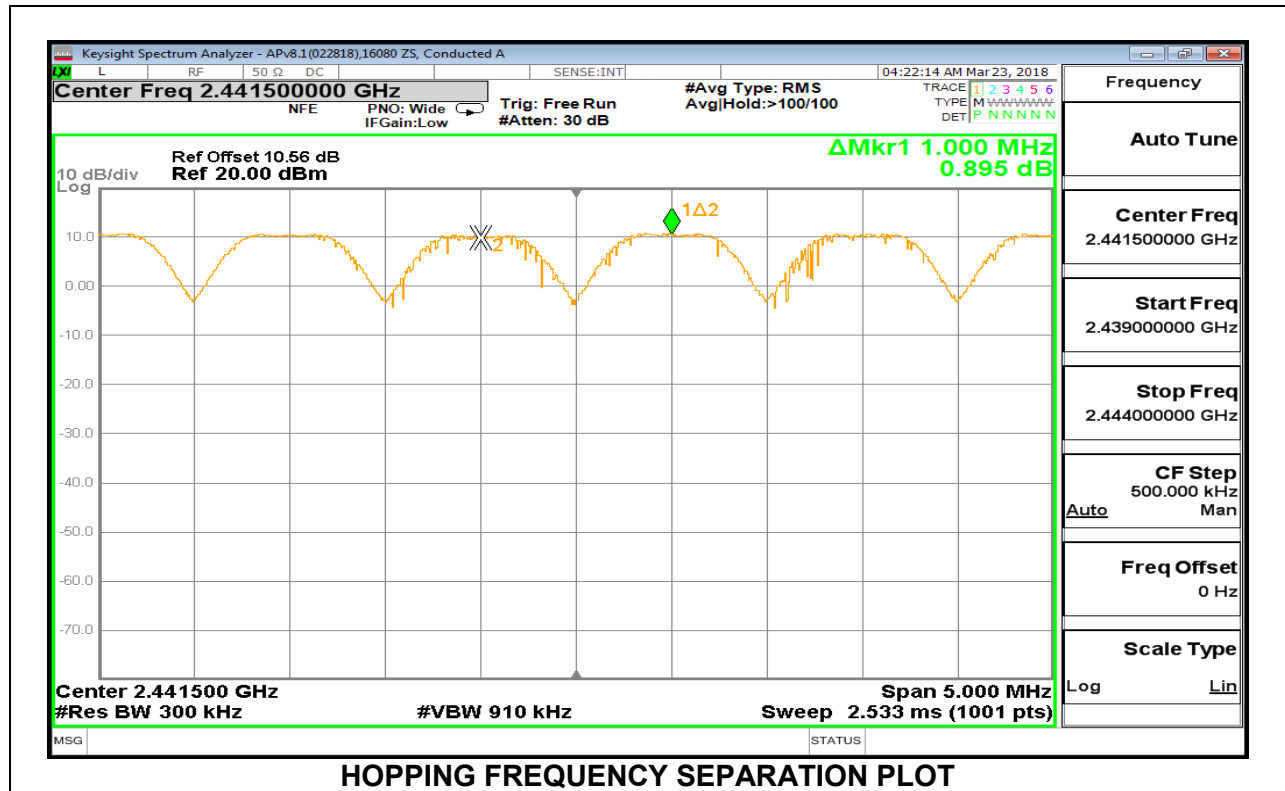

8.3.2. BLUETOOTH ENCHANCED DATA RATE 8PSK MODULATION

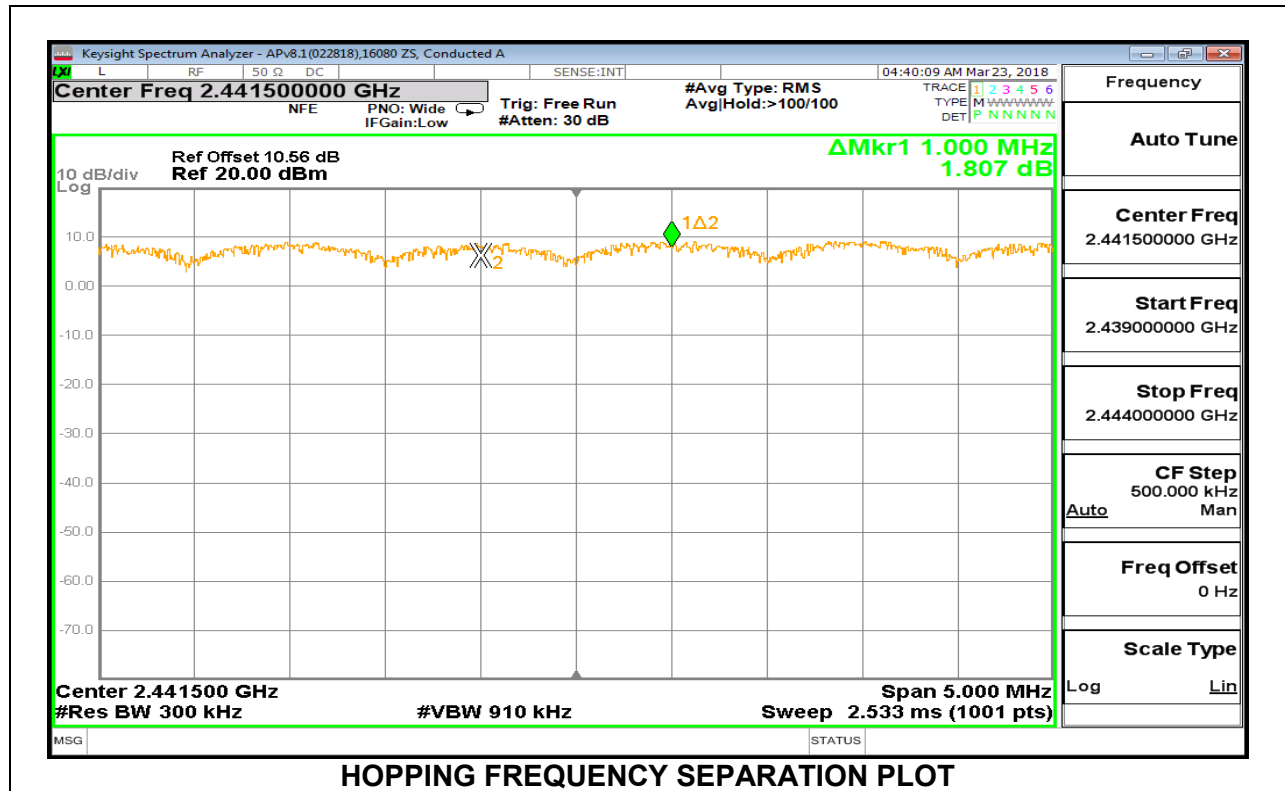

8.4. NUMBER OF HOPPING CHANNELS

LIMITS

FCC §15.247 (a) (1) (iii)

Frequency hopping systems in the 2400 – 2483.5 MHz band shall use at least 15 non-overlapping channels.

TEST PROCEDURE

The transmitter output is connected to a spectrum analyzer. The span is set to cover the entire authorized band, in either a single sweep or in multiple contiguous sweeps. The RBW is set to a maximum of 1 % of the span. The analyzer is set to Max Hold.

RESULTS

8.4.1. BLUETOOTH BASIC DATA RATE GFSK MODULATION

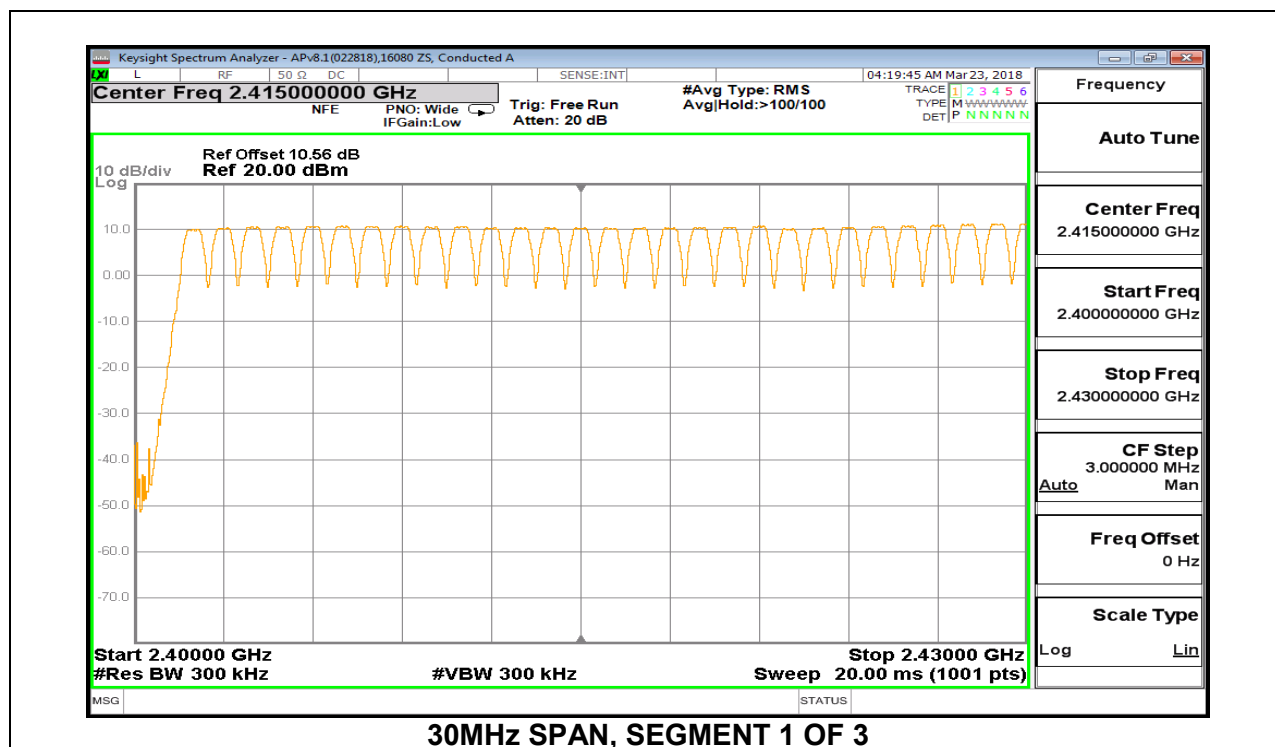
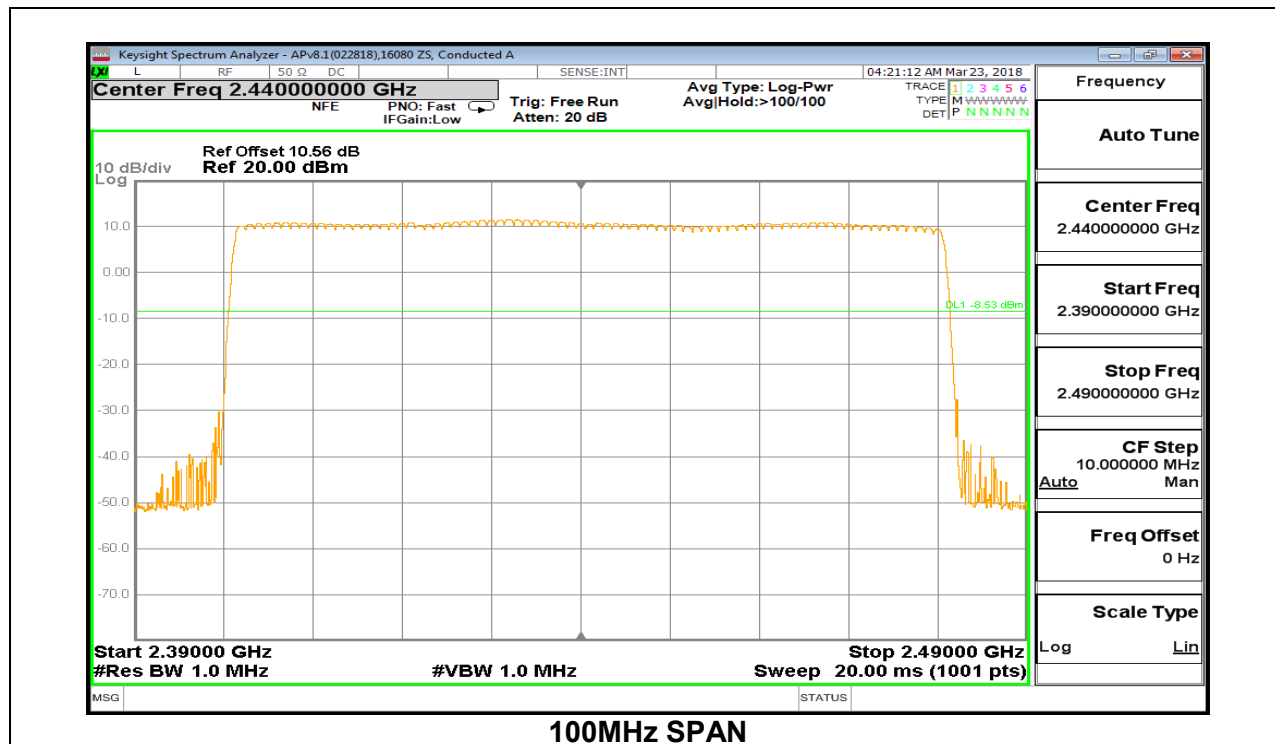

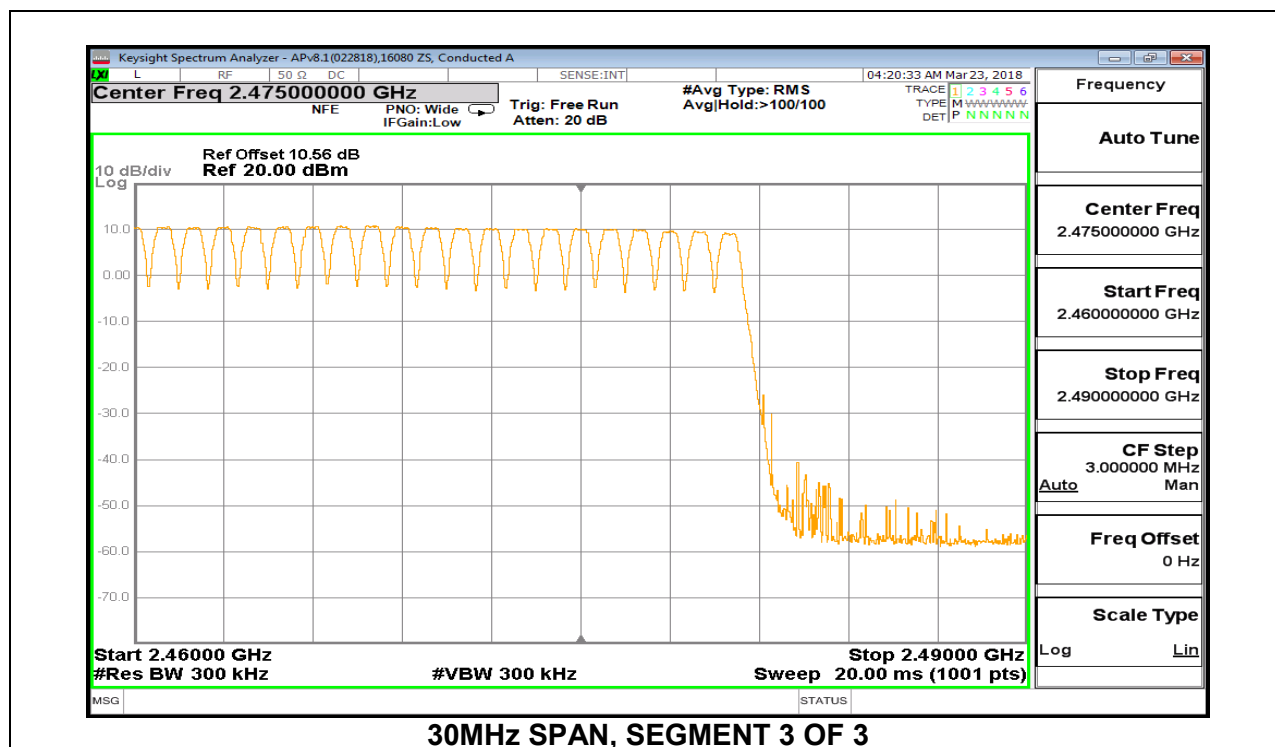
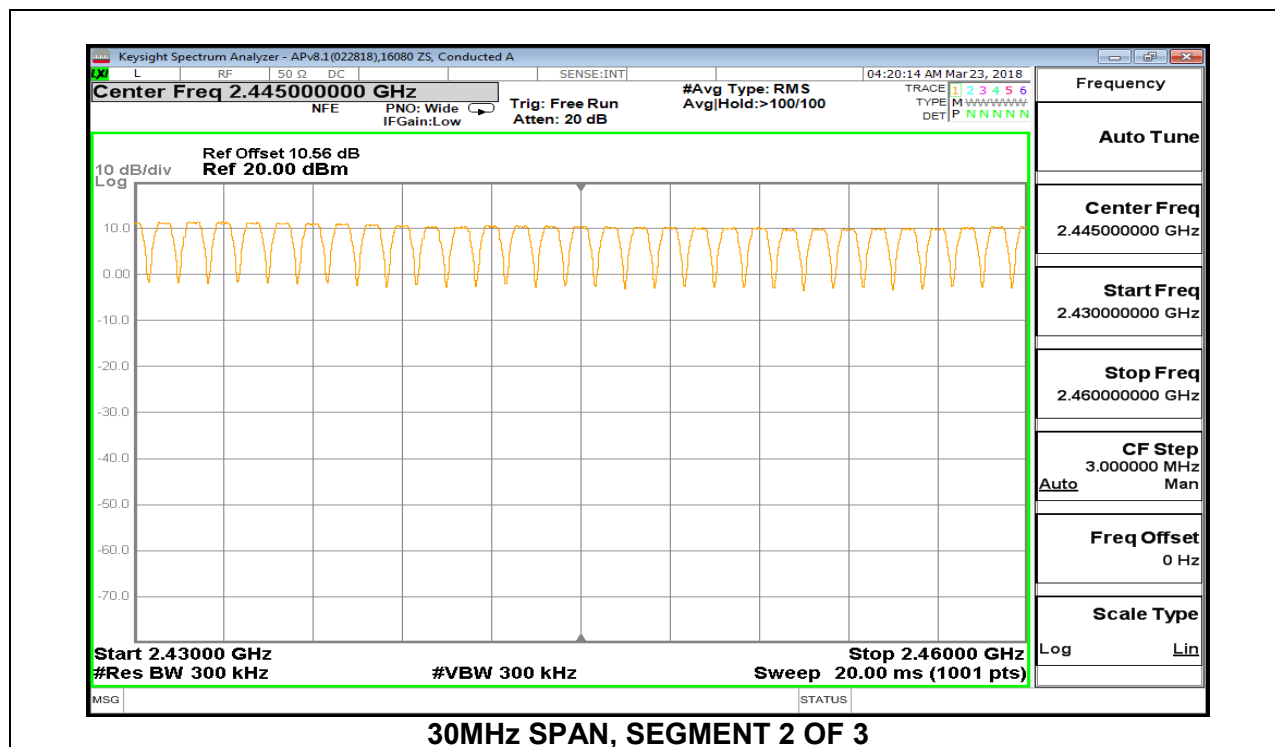

8.4.2. BLUETOOTH ENCHANCED DATA RATE 8PSK MODULATION

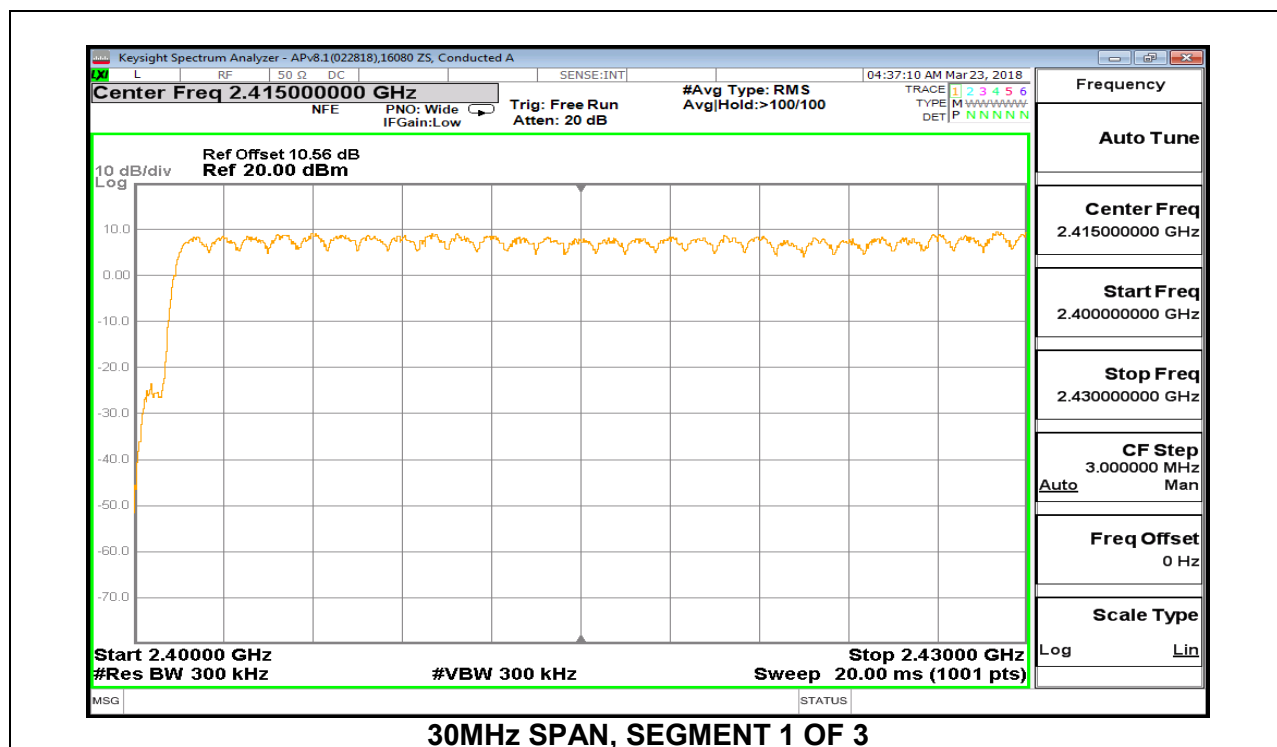
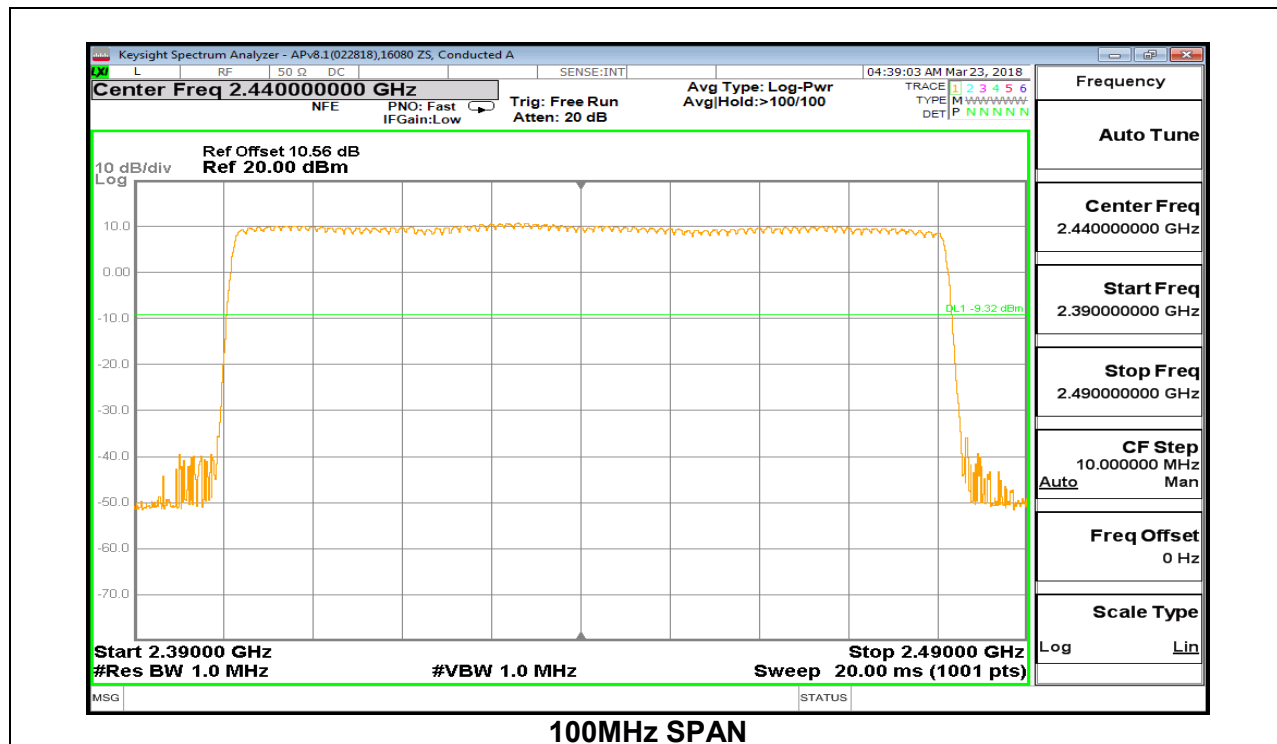

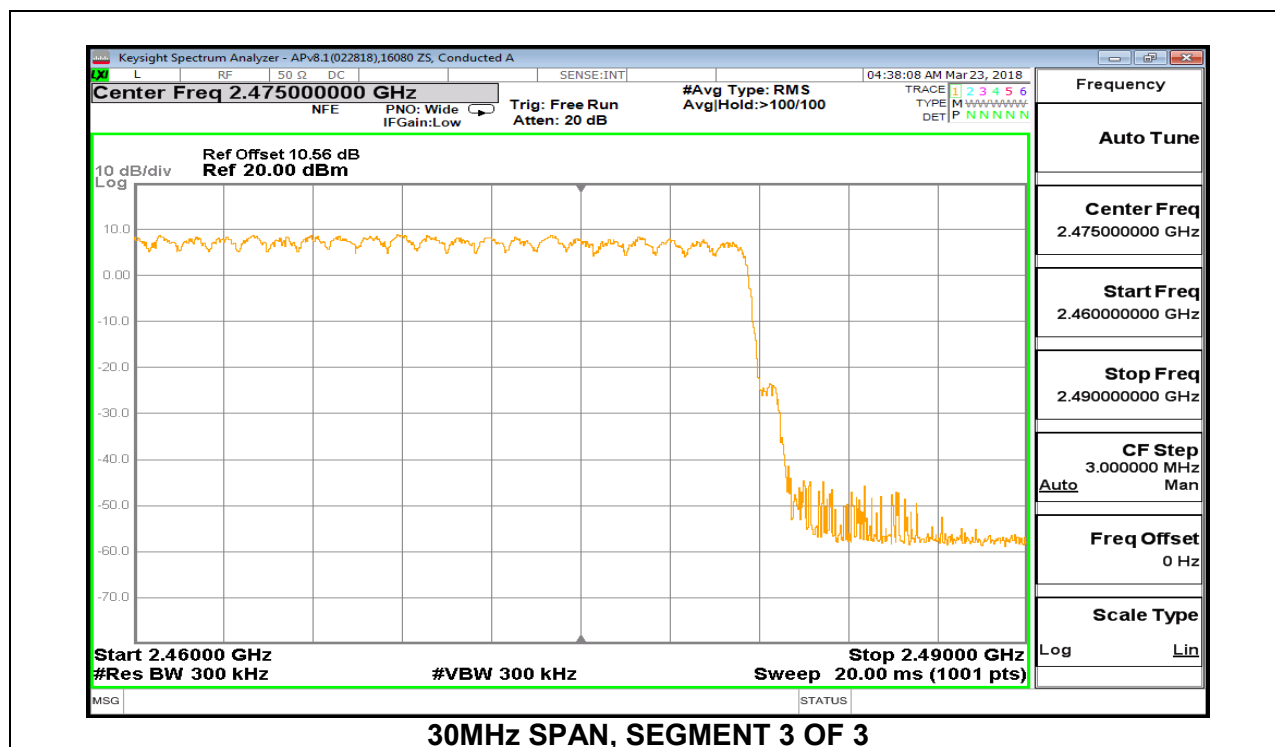
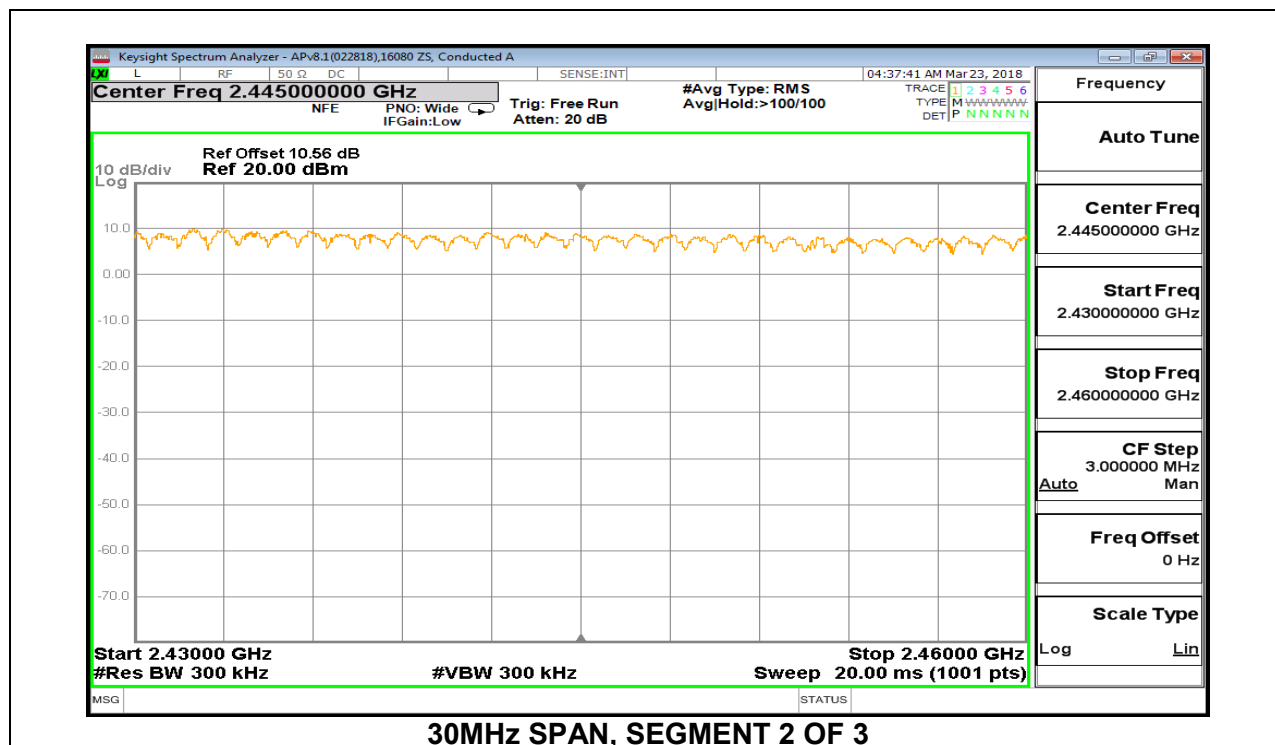

8.5. AVERAGE TIME OF OCCUPANCY

LIMITS

FCC §15.247 (a) (1) (iii)

The average time of occupancy on any channel shall not be greater than 0.4 seconds within a period of 0.4 seconds multiplied by the number of hopping channels employed.

TEST PROCEDURE

The transmitter output is connected to a spectrum analyzer. The span is set to 0 Hz, centered on a single, selected hopping channel. The width of a single pulse is measured in a fast scan. The number of pulses is measured in a 3.16 second scan, to enable resolution of each occurrence.

The average time of occupancy in the specified 3.16 second period (79 channels * 0.4 s) is equal to $10 * (\# \text{ of pulses in } 3.16 \text{ s}) * \text{ pulse width}$.

For AFH mode, the average time of occupancy in the specified 8 second period (20 channels * 0.4 seconds) is equal to $10 * (\# \text{ of pulses in } 0.8 \text{ s}) * \text{ pulse width}$.

RESULTS

8.5.1. BLUETOOTH BASIC DATA RATE GFSK MODULATION

DH Packet	Pulse Width (msec)	Number of Pulses in 3.16 seconds	Average Time of Occupancy (sec)	Limit (sec)	Margin (sec)
GFSK Normal Mode					
DH1	0.3825	33	0.1262	0.4	-0.2738
DH3	1.639	12	0.1967	0.4	-0.2033
DH5	2.887	13	0.3753	0.4	-0.0247
DH Packet	Pulse Width (sec)	Number of Pulses in 0.8 seconds	Average Time of Occupancy (sec)	Limit (sec)	Margin (sec)
GFSK AFH Mode					
DH1	0.3825	8.25	0.03156	0.4	-0.3684
DH3	1.639	3	0.04917	0.4	-0.3508
DH5	2.887	3.25	0.09383	0.4	-0.3062

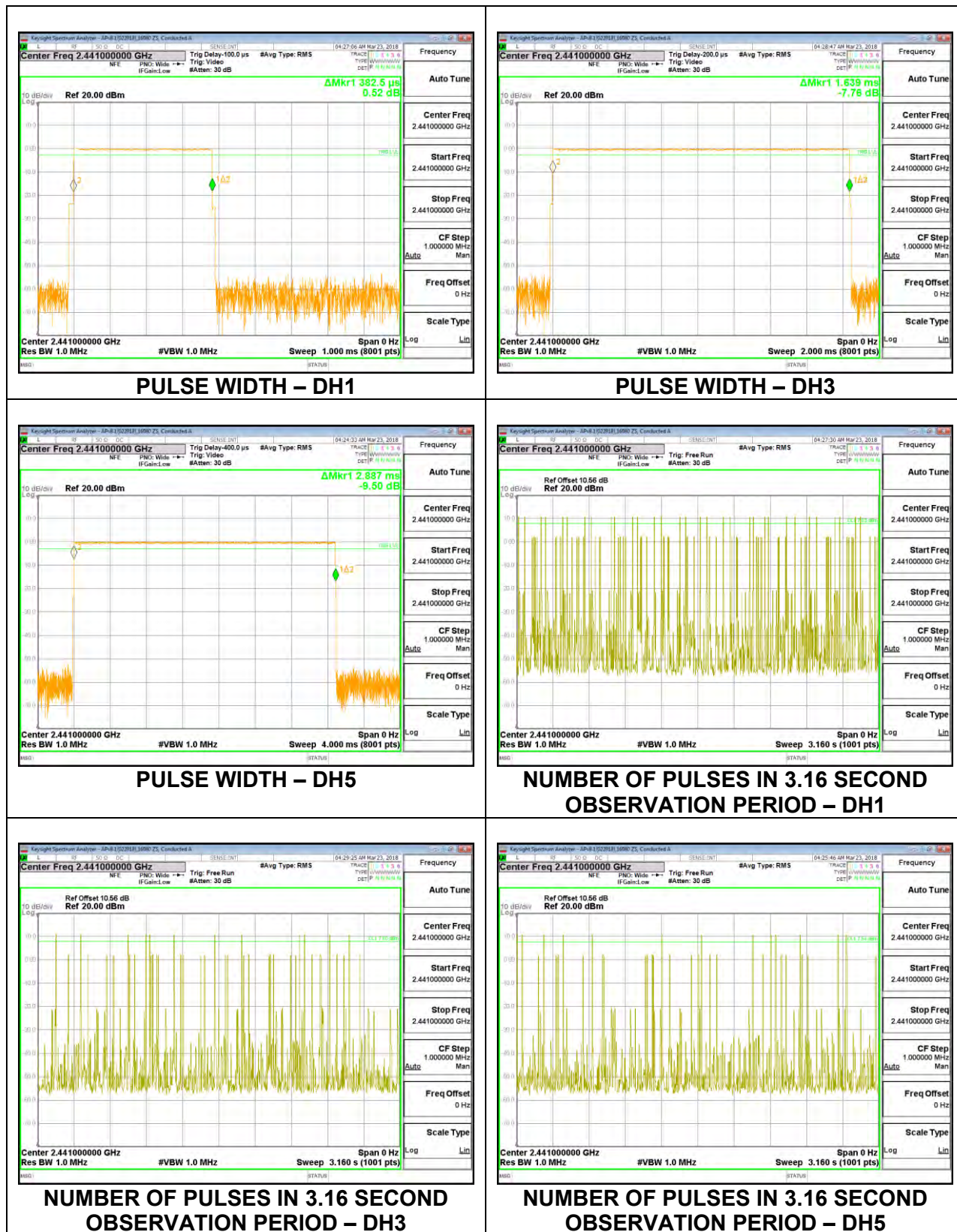

8.5.2. BLUETOOTH ENHANCED DATA RATE 8PSK MODULATION

DH Packet	Pulse Width (msec)	Number of Pulses in 3.16 seconds	Average Time of Occupancy (sec)	Limit (sec)	Margin (sec)
8PSK Normal Mode					
DH1	0.389	32	0.12448	0.4	-0.27552
DH3	1.64	12	0.1968	0.4	-0.2032
DH5	2.891	13	0.37583	0.4	-0.02417

Note: for AFH(8PSK) mode, please refer to the results of AFH(GFSK) mode; the channel selection and hopping rate are the same for both EDR and Basic Rate operation, data for Basic Rate in section 8.5.1 demonstrates compliance with channel occupancy when AFH is employed.

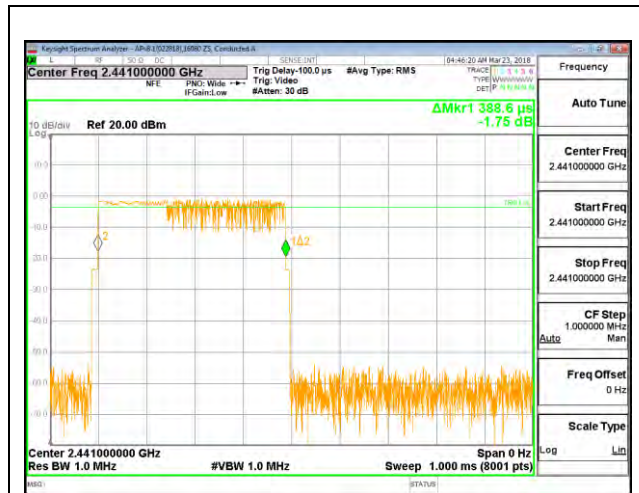

PULSE WIDTH – DH1

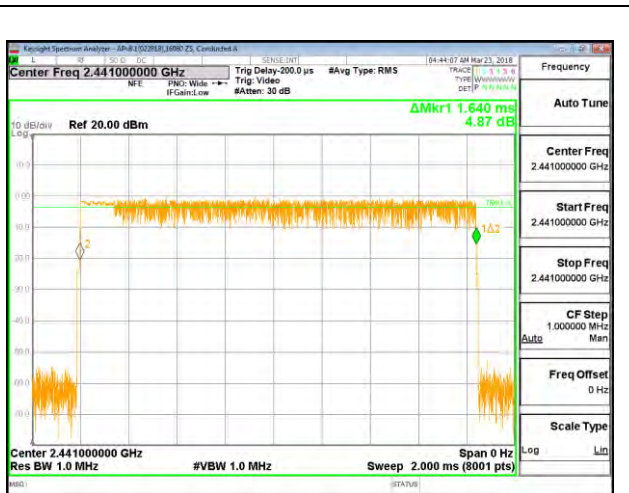

PULSE WIDTH – DH3

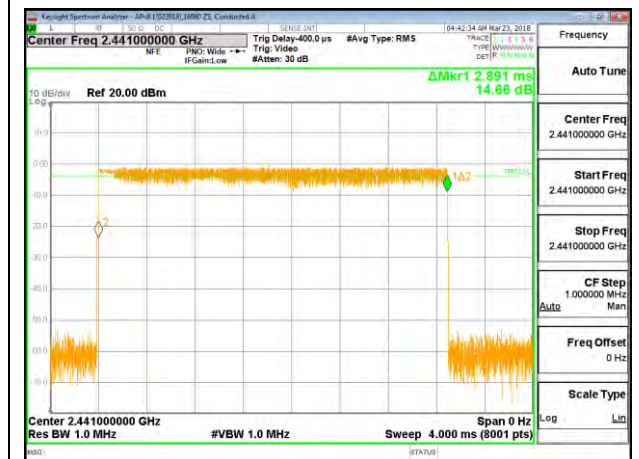

PULSE WIDTH – DH5

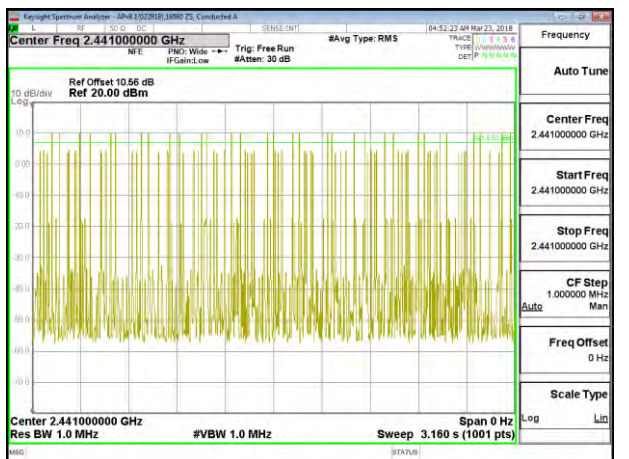

NUMBER OF PULSES IN 3.16 SECOND OBSERVATION PERIOD – DH1

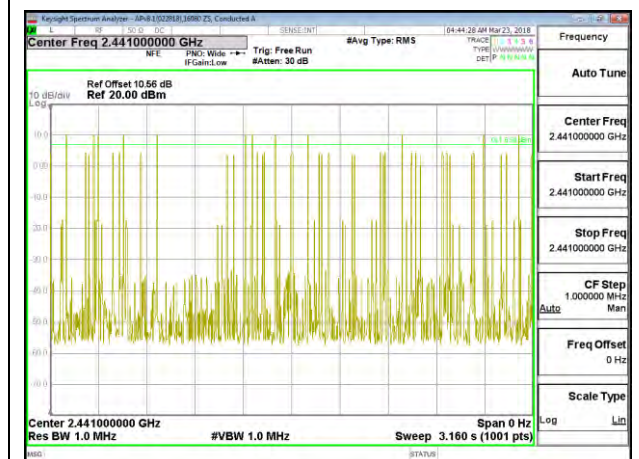

NUMBER OF PULSES IN 3.16 SECOND OBSERVATION PERIOD – DH3



NUMBER OF PULSES IN 3.16 SECOND OBSERVATION PERIOD – DH5

8.6. OUTPUT POWER

LIMITS

§15.247 (b) (1)

The maximum antenna gain is less than 6 dBi, therefore the limit is 30 dBm.

TEST PROCEDURE

The transmitter output is connected to a power meter. The cable assembly insertion loss was entered as an offset in the power meter to allow for a gated peak reading of power.

RESULTS

8.6.1. BLUETOOTH BASIC DATA RATE GFSK MODULATION

Tested By:	16080 ZS
Date:	4/2/2018

Channel	Frequency (MHz)	Output Peak Power (dBm)	Limit (dBm)	Margin (dB)
Low	2402	10.05	30	-19.95
Middle	2441	10.66	30	-19.34
High	2480	9.68	30	-20.32

8.6.2. BLUETOOTH ENCHANCED DATA RATE 8PSK MODULATION

Tested By:	16080 ZS
Date:	4/2/2018

Channel	Frequency (MHz)	Output Peak Power (dBm)	Limit (dBm)	Margin (dB)
Low	2402	9.57	30	-20.43
Middle	2441	10.20	30	-19.80
High	2480	9.31	30	-20.69

8.7. AVERAGE POWER

LIMITS

None; for reporting purposes only

TEST PROCEDURE

The transmitter output is connected to a power meter. The cable assembly insertion loss was entered as an offset in the power meter to allow for a gated Average reading of power.

RESULTS

8.7.1. BLUETOOTH BASIC DATA RATE GFSK MODULATION

Tested By:	16080 ZS
Date	4/2/2018

Channel	Frequency (MHz)	Average Power (dBm)
Low	2402	9.9
Middle	2441	10.37
High	2480	9.52

8.7.2. BLUETOOTH ENCHANCED DATA RATE 8PSK MODULATION

Tested By:	16080 ZS
Date	4/2/2018

Channel	Frequency (MHz)	Average Power (dBm)
Low	2402	7.35
Middle	2441	8.12
High	2480	7.17

8.8. CONDUCTED SPURIOUS EMISSIONS

LIMITS

FCC §15.247 (d)

Limit = -20 dBc

TEST PROCEDURE

The transmitter output is connected to a spectrum analyzer. The resolution bandwidth is set to 100 kHz. The video bandwidth is set to 300 kHz.

The spectrum from 30 MHz to 26 GHz is investigated with the transmitter set to the lowest, middle, and highest channels.

The bandedges at 2.4 and 2.4835 GHz are investigated with the transmitter set to the normal hopping mode.

RESULTS

8.8.1. BLUETOOTH BASIC DATA RATE GFSK MODULATION

SPURIOUS EMISSIONS, NON-HOPPING

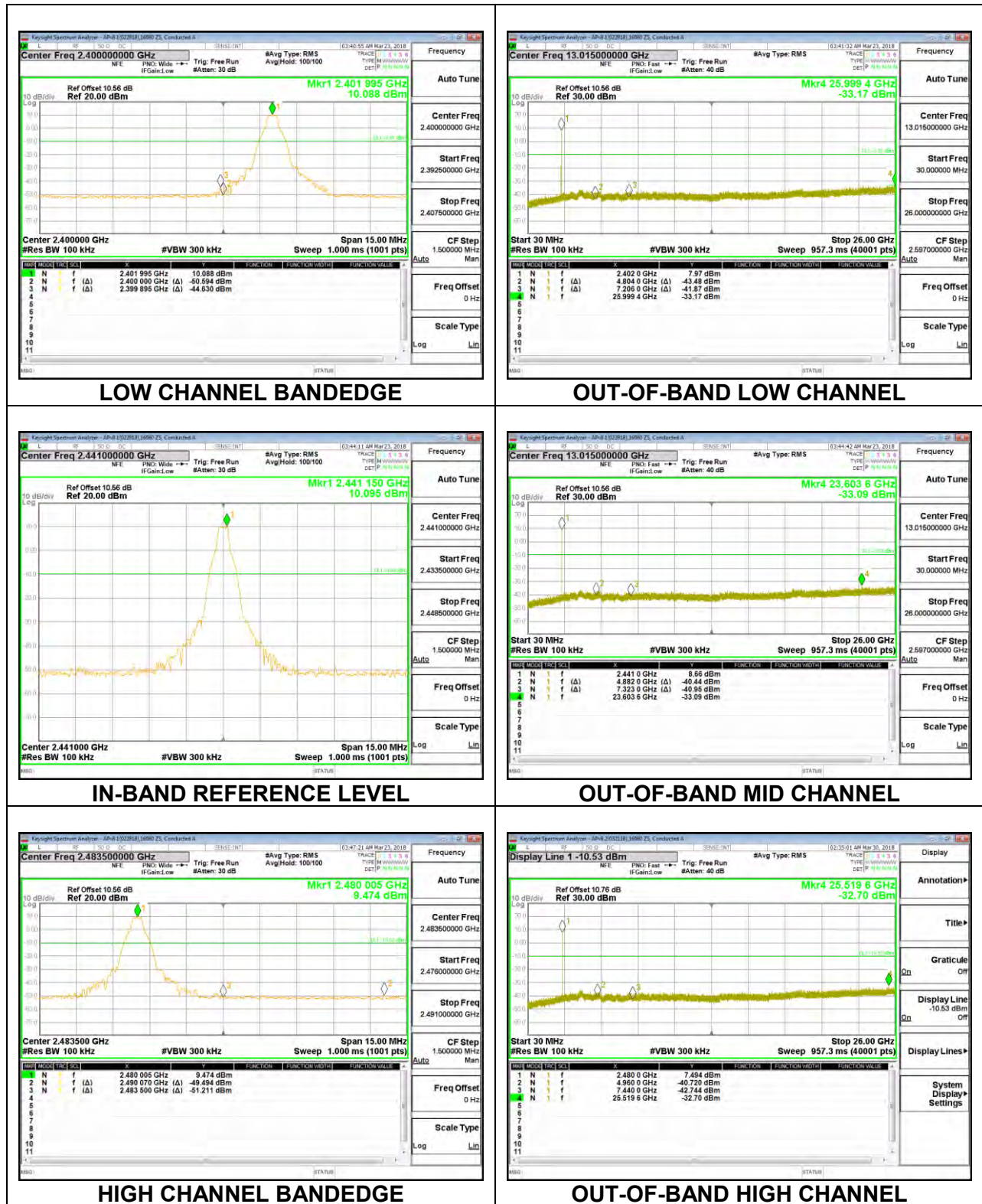

SPURIOUS BANDEDGE EMISSIONS WITH HOPPING ON

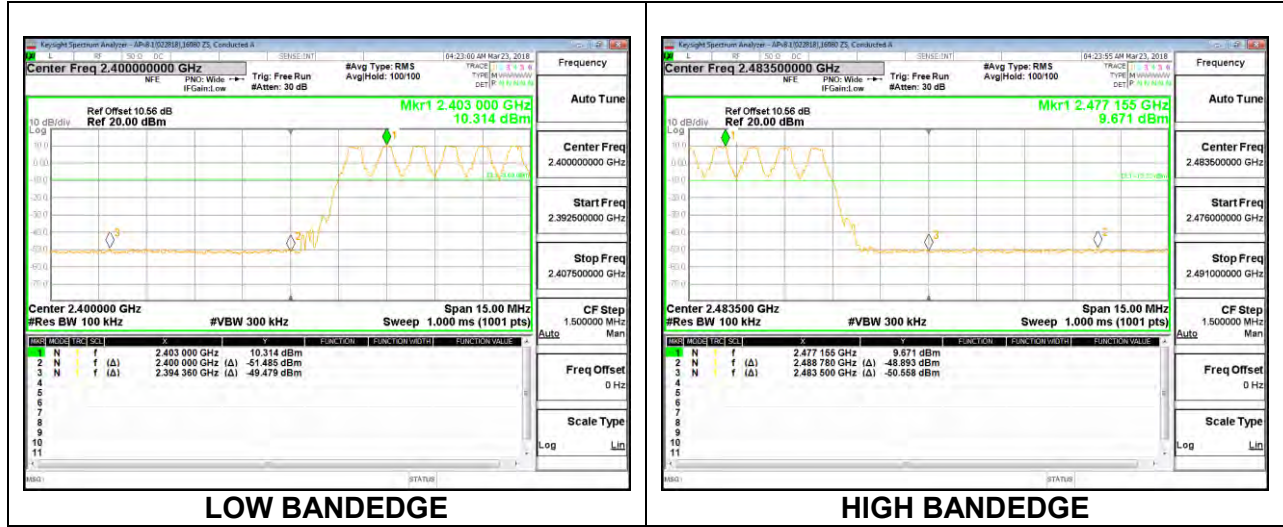

8.8.2. BLUETOOTH ENHANCED DATA RATE 8PSK MODULATION

SPURIOUS EMISSIONS, NON-HOPPING

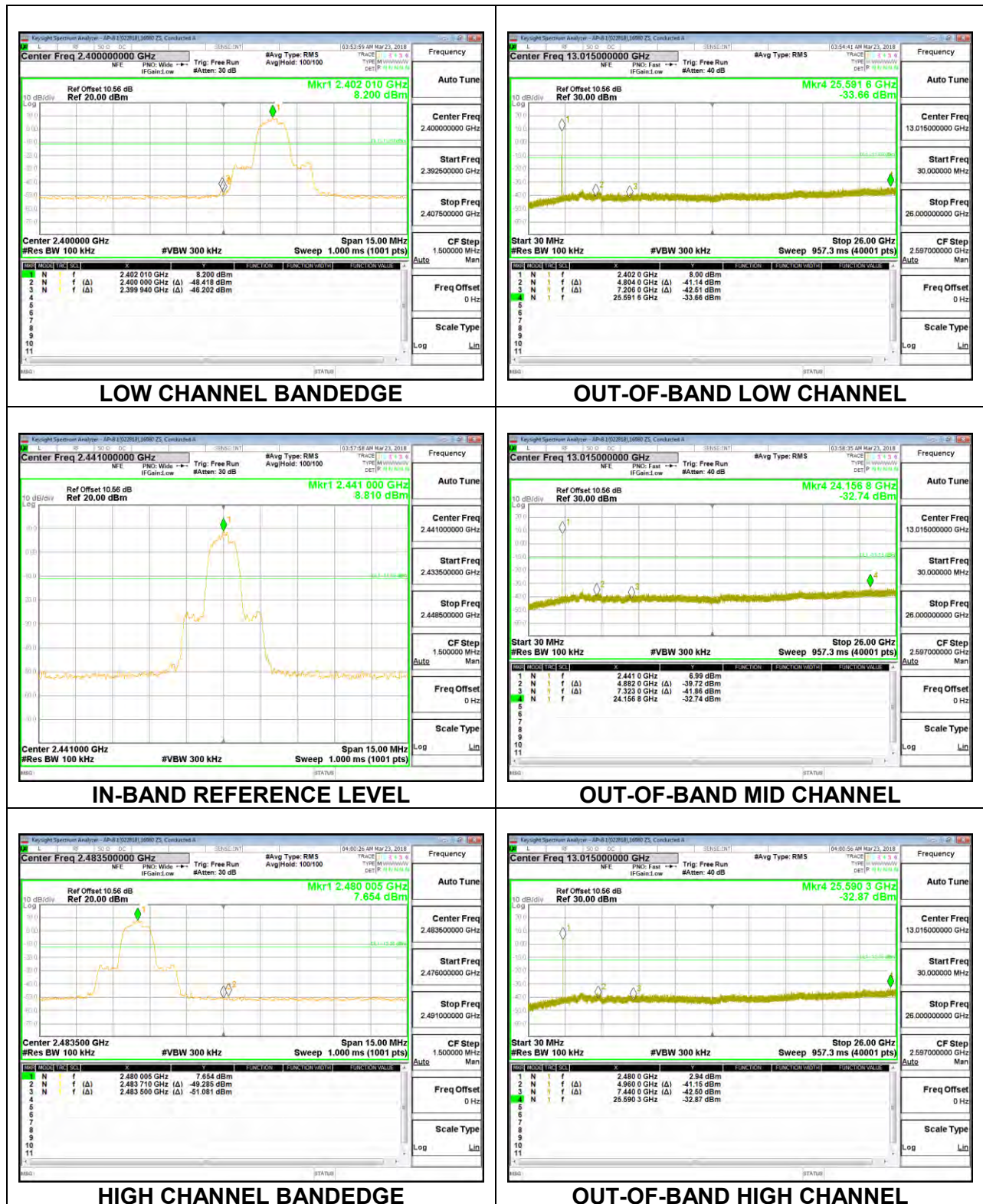

SPURIOUS BANDEGE EMISSIONS WITH HOPPING ON



9. RADIATED TEST RESULTS

LIMITS

FCC §15.205 and §15.209

Frequency Range (MHz)	Field Strength Limit (uV/m) at 3 m	Field Strength Limit (dBuV/m) at 3 m
0.009-0.490	2400/F(kHz) @ 300 m	-
0.490-1.705	24000/F(kHz) @ 30 m	-
1.705 - 30	30 @ 30m	-
30 - 88	100	40
88 - 216	150	43.5
216 - 960	200	46
Above 960	500	54

TEST PROCEDURE

The EUT is placed on a non-conducting table 80 cm above the ground plane for measurement below 1GHz; 1.5 m above the ground plane for measurement above 1GHz. The antenna to EUT distance is 3 meters. The EUT is configured in accordance with ANSI C63.10. The EUT is set to transmit in a continuous mode.

For measurements below 1 GHz the resolution bandwidth is set to 100 kHz for peak detection measurements or 120 kHz for quasi-peak detection measurements. Peak detection is used unless otherwise noted as quasi-peak.

For measurements above 1 GHz the resolution bandwidth is set to 1 MHz, then the video bandwidth is set to 3 MHz for peak measurements and 1 MHz resolution bandwidth with 1/T (360 Hz) video bandwidth with peak detector for average measurements.

The spectrum from 1 GHz to 18 GHz is investigated with the transmitter set to the lowest, middle, and highest channels in each applicable band. Below 1GHz and above 18GHz emissions, the channel with the highest output power was tested.

The frequency range of interest is monitored at a fixed antenna height and EUT azimuth. The EUT is rotated through 360 degrees to maximize emissions received. The antenna is scanned from 1 to 4 meters above the ground plane to further maximize the emission. Measurements are made with the antenna polarized in both the vertical and the horizontal positions.

9.1. TRANSMITTER ABOVE 1 GHz

9.1.1. BLUETOOTH BASIC DATA RATE GFSK MODULATION

BANDEDGE (LOW CHANNEL)

HORIZONTAL RESULT

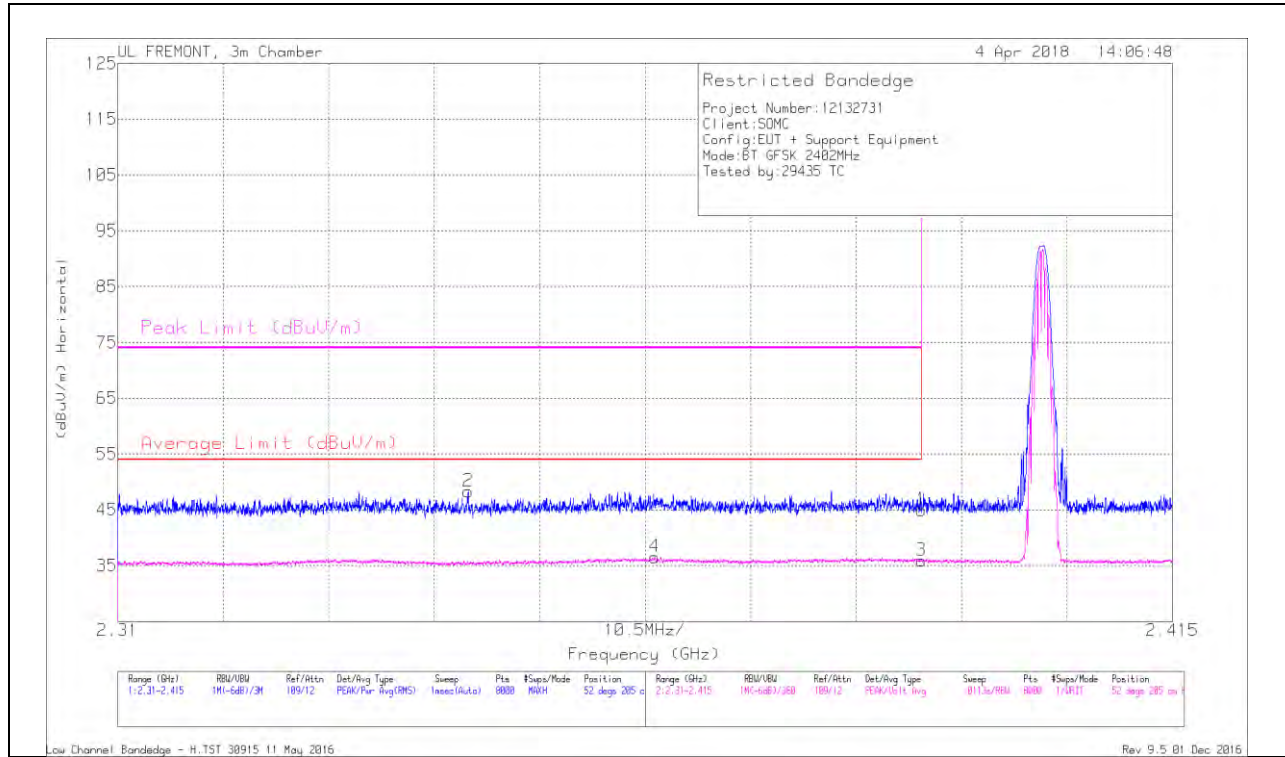

Marker	Frequency (GHz)	Meter Reading (dBuV)	Det	AF T120 (dB/m)	Amp/Cbl/Fitr/P ad (dB)	Corrected Reading (dBuV/m)	Average Limit (dBuV/m)	Margin (dB)	Peak Limit (dBuV/m)	PK Margin (dB)	Azimuth (Degs)	Height (cm)	Polarity
2	2.345	38.33	Pk	31.7	-21.7	48.33	-	-	74	-25.67	52	205	H
4	2.363	25.87	VA1T	31.7	-21.1	36.47	54	-17.53	-	-	52	205	H
1	2.39	34.49	Pk	31.9	-21.4	44.99	-	-	74	-29.01	52	205	H
3	2.39	25.36	VA1T	31.9	-21.4	35.86	54	-18.14	-	-	52	205	H

Pk - Peak detector

VA1T - FHSS: Linear Voltage Average $V_B=1/T_{on}$ where: T_{on} is transmit duration

VERTICAL RESULT

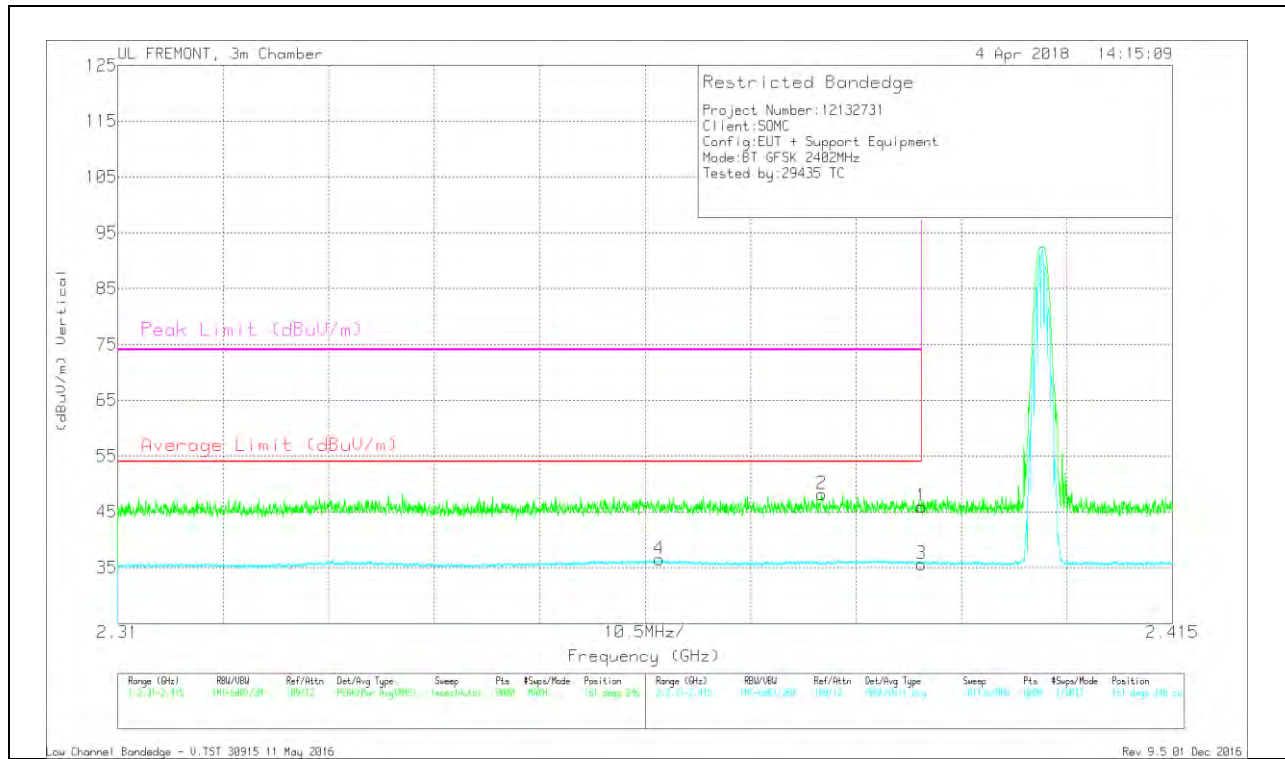

Marker	Frequency (GHz)	Meter Reading (dBuV)	Det	AF T120 (dB/m)	Amp/Cbl/Filtr/Pad (dB)	Corrected Reading (dBuV/m)	Average Limit (dBuV/m)	Margin (dB)	Peak Limit (dBuV/m)	PK Margin (dB)	Azimuth (Degs)	Height (cm)	Polarity
4	2.364	25.89	VA1T	31.7	-21.1	36.49	54	-17.51	-	-	161	246	V
2	2.38	37.67	PK	31.8	-21.3	48.17	-	-	74	-25.83	161	246	V
1	2.39	35.47	PK	31.9	-21.4	45.97	-	-	74	-28.03	161	246	V
3	2.39	25.16	VA1T	31.9	-21.4	35.66	54	-18.34	-	-	161	246	V

Pk - Peak detector

VA1T - FHSS: Linear Voltage Average $V_B=1/T_{on}$ where: T_{on} is transmit duration

BANDEDGE (HIGH CHANNEL)

HORIZONTAL RESULT

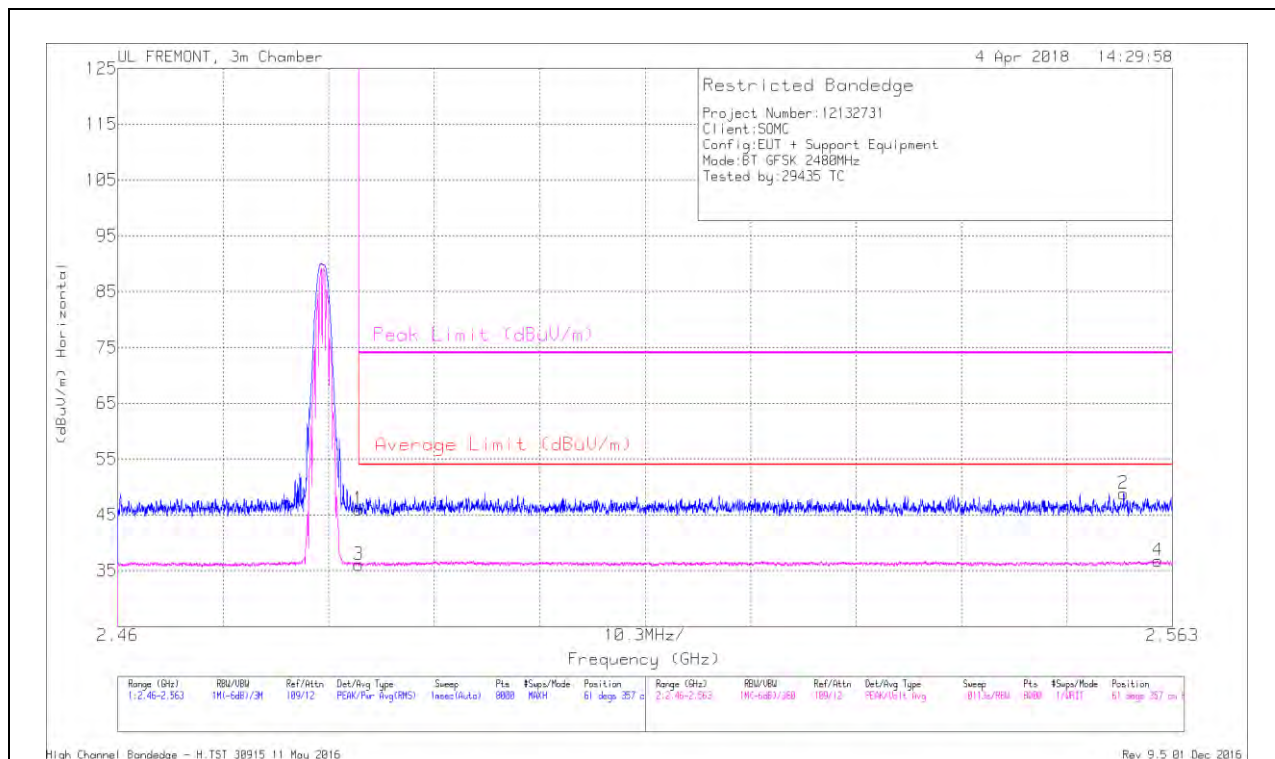

Marker	Frequency (GHz)	Meter Reading (dBuV)	Det	AF T120 (dB/m)	Amp/Cbl/Filtr/Pad (dB)	Corrected Reading (dBuV/m)	Average Limit (dBuV/m)	Margin (dB)	Peak Limit (dBuV/m)	PK Margin (dB)	Azimuth (Degs)	Height (cm)	Polarity
1	2.484	35.58	Pk	32.2	-21.8	45.98	-	-	74	-28.02	61	357	H
3	2.484	25.64	VA1T	32.2	-21.8	36.04	54	-17.96	-	-	61	357	H
2	2.558	38.25	Pk	32.3	-21.7	48.85	-	-	74	-25.15	61	357	H
4	2.562	26.21	VA1T	32.3	-21.7	36.81	54	-17.19	-	-	61	357	H

Pk - Peak detector

VA1T - FHSS: Linear Voltage Average VB=1/Ton where: Ton is transmit duration

VERTICAL RESULT

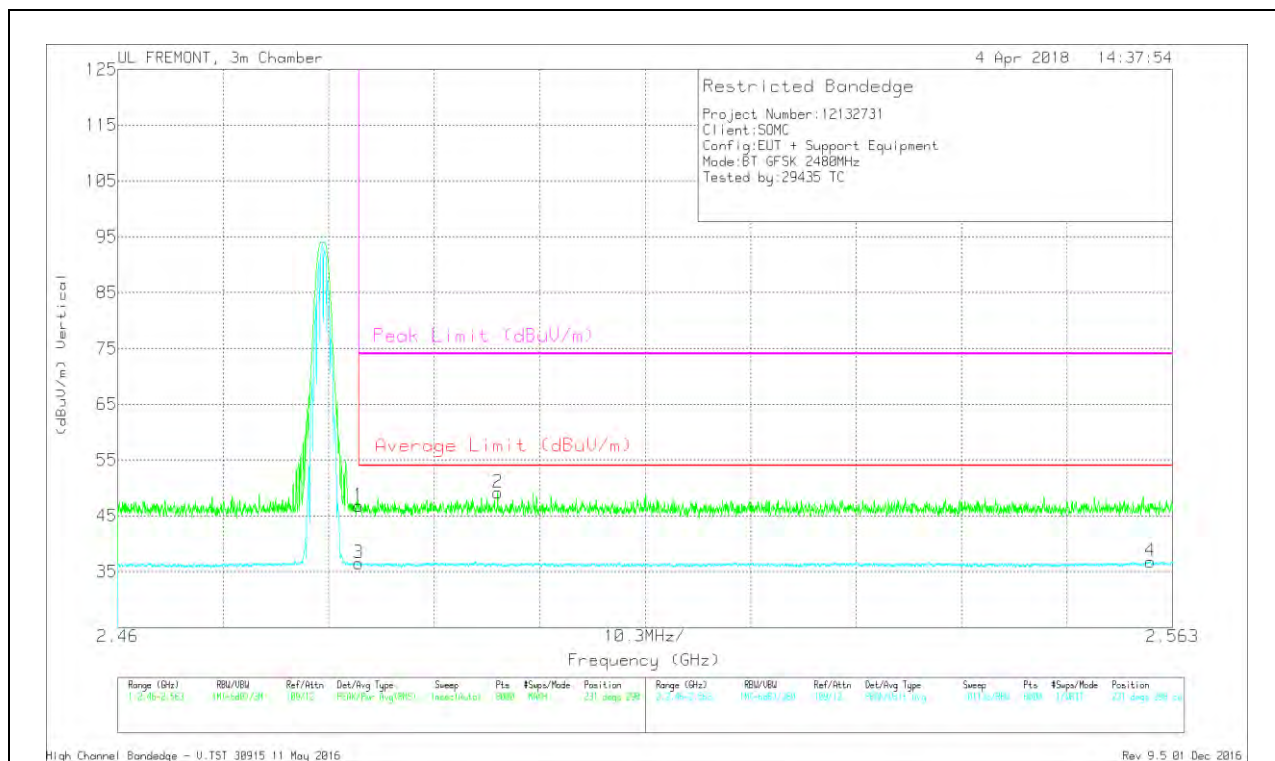

Marker	Frequency (GHz)	Meter Reading (dBuV)	Det	AF T120 (dB/m)	Amp/Cbl/Filtr/Pad (dB)	Corrected Reading (dBuV/m)	Average Limit (dBuV/m)	Margin (dB)	Peak Limit (dBuV/m)	PK Margin (dB)	Azimuth (Degs)	Height (cm)	Polarity
1	2.484	36.36	Pk	32.2	-21.8	46.76	-	-	74	-27.24	231	298	V
3	2.484	26.13	VA1T	32.2	-21.8	36.53	54	-17.47	-	-	231	298	V
2	2.497	38.69	Pk	32.3	-21.8	49.19	-	-	74	-24.81	231	298	V
4	2.561	26.22	VA1T	32.3	-21.7	36.82	54	-17.18	-	-	231	298	V

Pk - Peak detector

VA1T - FHSS: Linear Voltage Average $V_B=1/T_{on}$ where: T_{on} is transmit duration

HARMONICS AND SPURIOUS EMISSIONS

LOW CHANNEL RESULTS

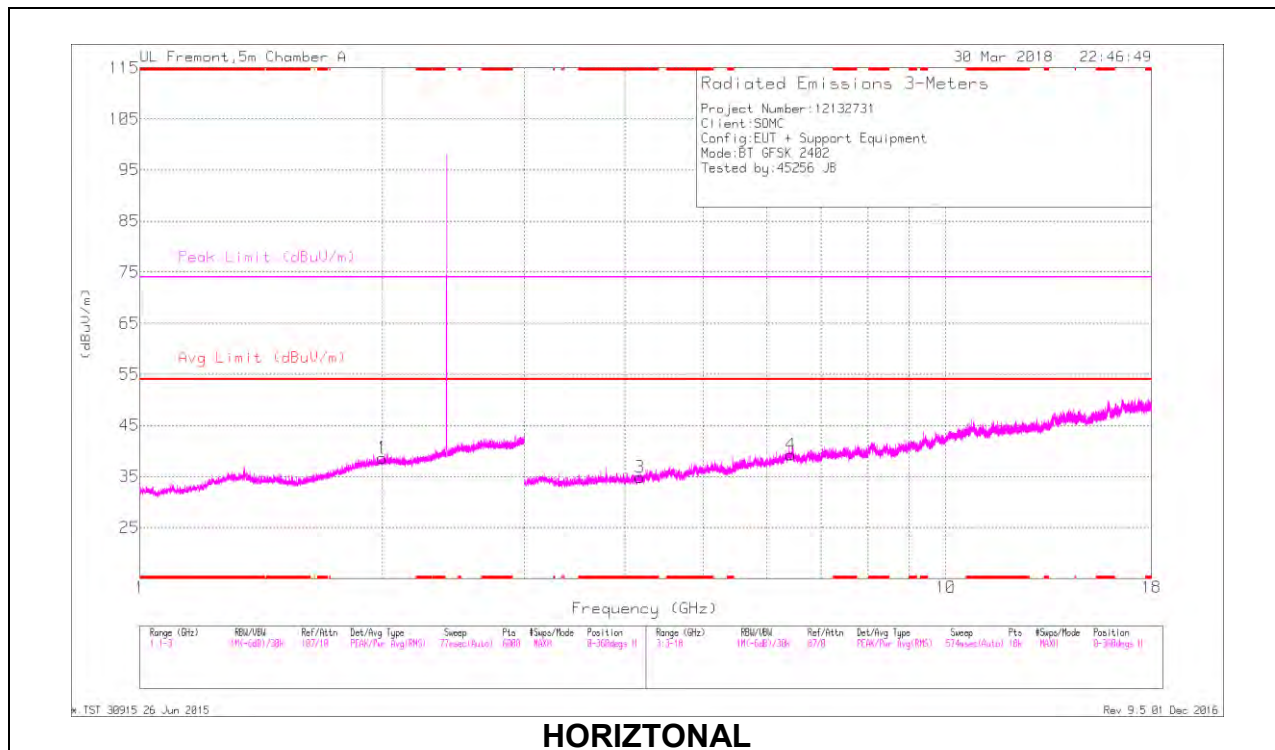

HORIZONTAL

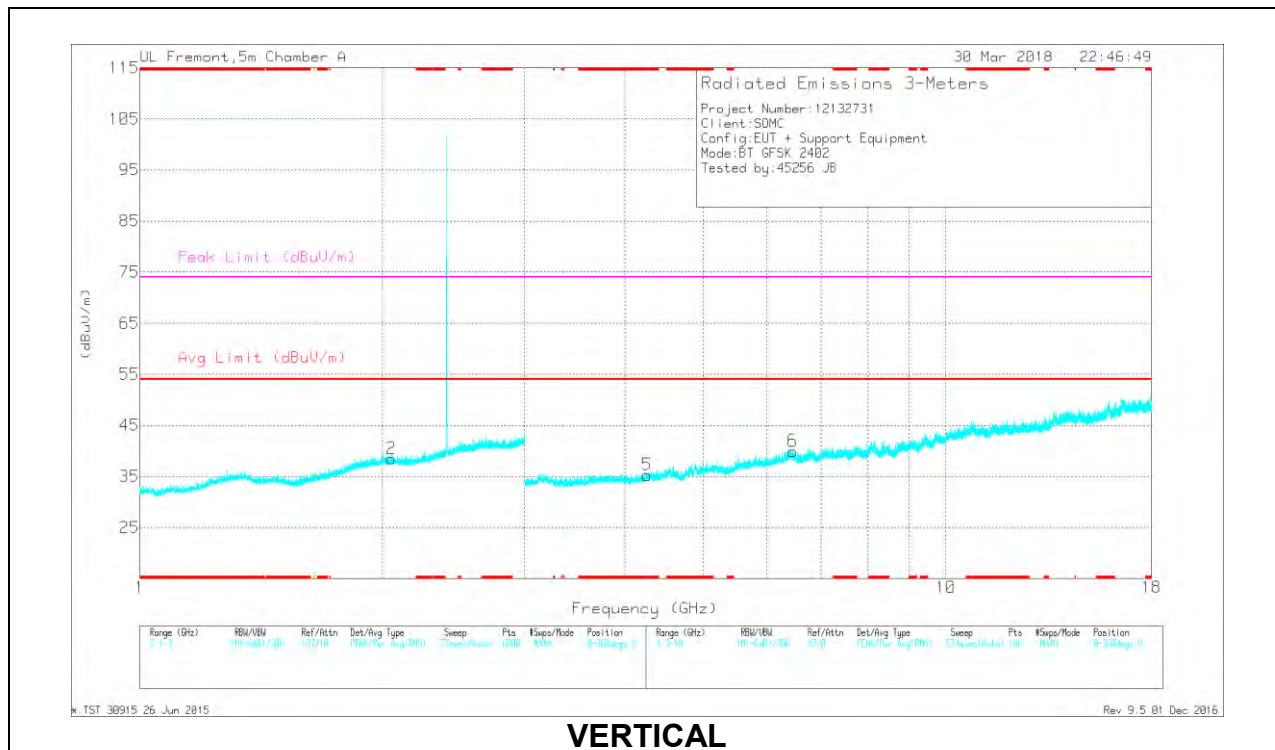

VERTICAL

RADIATED EMISSIONS

Trace Markers

Marker	Frequency (GHz)	Meter Reading (dBuV)	Det	AF T862 (dB/m)	Amp/Cbl/Filtr/Pad (dB)	Corrected Reading (dBuV/m)	Avg Limit (dBuV/m)	Margin (dB)	Peak Limit (dBuV/m)	PK Margin (dB)	Azimuth (Degs)	Height (cm)	Polarity
3	* 4.176	29.73	Pk	33.4	-28.3	34.83	-	-	74	-39.17	0-360	199	H
5	* 4.263	29.66	Pk	33.5	-27.9	35.26	-	-	74	-38.74	0-360	200	V
1	1.999	30.69	Pk	31.4	-23.5	38.59	-	-	-	-	0-360	199	H
2	2.052	30.75	Pk	31.4	-23.6	38.55	-	-	-	-	0-360	101	V
4	6.422	27.8	Pk	35.8	-24.3	39.3	-	-	-	-	0-360	199	H
6	6.46	27.75	Pk	35.8	-23.6	39.95	-	-	-	-	0-360	200	V

* - indicates frequency in CFR47 Pt 15 Restricted Band
 Pk - Peak detector

Radiated Emissions

Frequency (GHz)	Meter Reading (dBuV)	Det	AF T862 (dB/m)	Amp/Cbl/Filtr/Pad (dB)	Corrected Reading (dBuV/m)	Avg Limit (dBuV/m)	Margin (dB)	Peak Limit (dBuV/m)	PK Margin (dB)	Azimuth (Degs)	Height (cm)	Polarity
* 4.176	34.69	PKFH	33.4	-28.4	39.69	-	-	74	-34.31	335	178	H
* 4.174	23.84	VA1T	33.4	-28.3	28.94	54	-25.06	-	-	335	178	H
* 4.262	35.45	PKFH	33.5	-27.9	41.05	-	-	74	-32.95	299	253	V
* 4.265	24	VA1T	33.5	-28	29.5	54	-24.5	-	-	299	253	V

* - indicates frequency in CFR47 Pt 15 Restricted Band
 PKFH - FHSS: RB=100k/1MHz VB=3 x RB, Peak

MID CHANNEL RESULTS

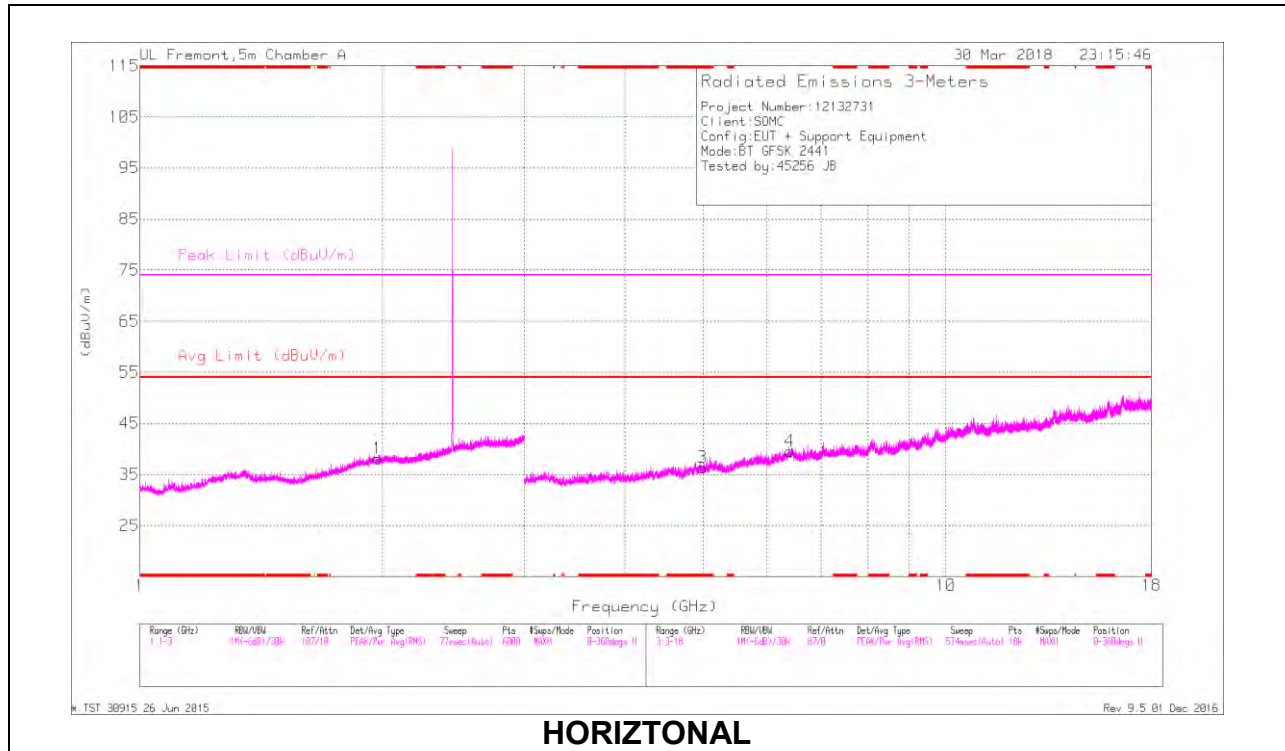

HORIZONTAL

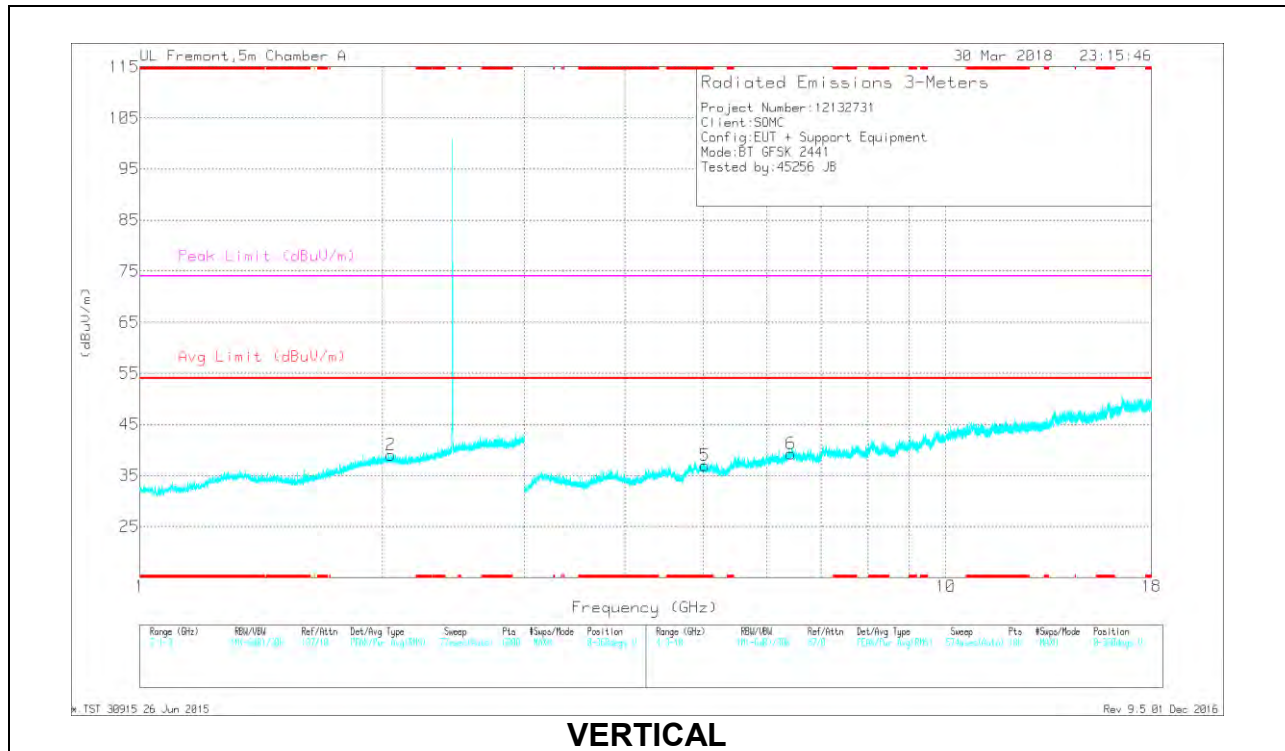

VERTICAL

RADIATED EMISSIONS

Trace Markers

Marker	Frequency (GHz)	Meter Reading (dBuV)	Det	AF T862 (dB/m)	Amp/Cbl/Filtr/Pad (dB)	Corrected Reading (dBuV/m)	Avg Limit (dBuV/m)	Margin (dB)	Peak Limit (dBuV/m)	PK Margin (dB)	Azimuth (Degs)	Height (cm)	Polarity
3	* 4.992	29.92	Pk	34.3	-27.9	36.32	-	-	74	-37.68	0-360	101	H
5	* 5.026	30.8	Pk	34.3	-28.1	37	-	-	74	-37	0-360	200	V
1	1.973	30.35	Pk	31.4	-23.6	38.15	-	-	-	-	0-360	102	H
2	2.047	31.18	Pk	31.4	-23.6	38.98	-	-	-	-	0-360	200	V
4	6.4	27.9	Pk	35.8	-24.2	39.5	-	-	-	-	0-360	199	H
6	6.424	27.76	Pk	35.8	-24.3	39.26	-	-	-	-	0-360	101	V

* - indicates frequency in CFR47 Pt 15 Restricted Band
 Pk - Peak detector

Radiated Emissions

Frequency (GHz)	Meter Reading (dBuV)	Det	AF T862 (dB/m)	Amp/Cbl/Filtr/Pad (dB)	Corrected Reading (dBuV/m)	Avg Limit (dBuV/m)	Margin (dB)	Peak Limit (dBuV/m)	PK Margin (dB)	Azimuth (Degs)	Height (cm)	Polarity
* 4.991	35.16	PKFH	34.3	-27.9	41.56	-	-	74	-32.44	244	303	H
* 4.991	24.25	VA1T	34.3	-27.9	30.65	54	-23.35	-	-	244	303	H
* 5.028	34.76	PKFH	34.3	-28.1	40.96	-	-	74	-33.04	324	307	V
* 5.024	24.15	VA1T	34.3	-28.1	30.35	54	-23.65	-	-	324	307	V

* - indicates frequency in CFR47 Pt 15 Restricted Band
 PKFH - FHSS: RB=100k/1MHz VB=3 x RB, Peak

HIGH CHANNEL RESULTS

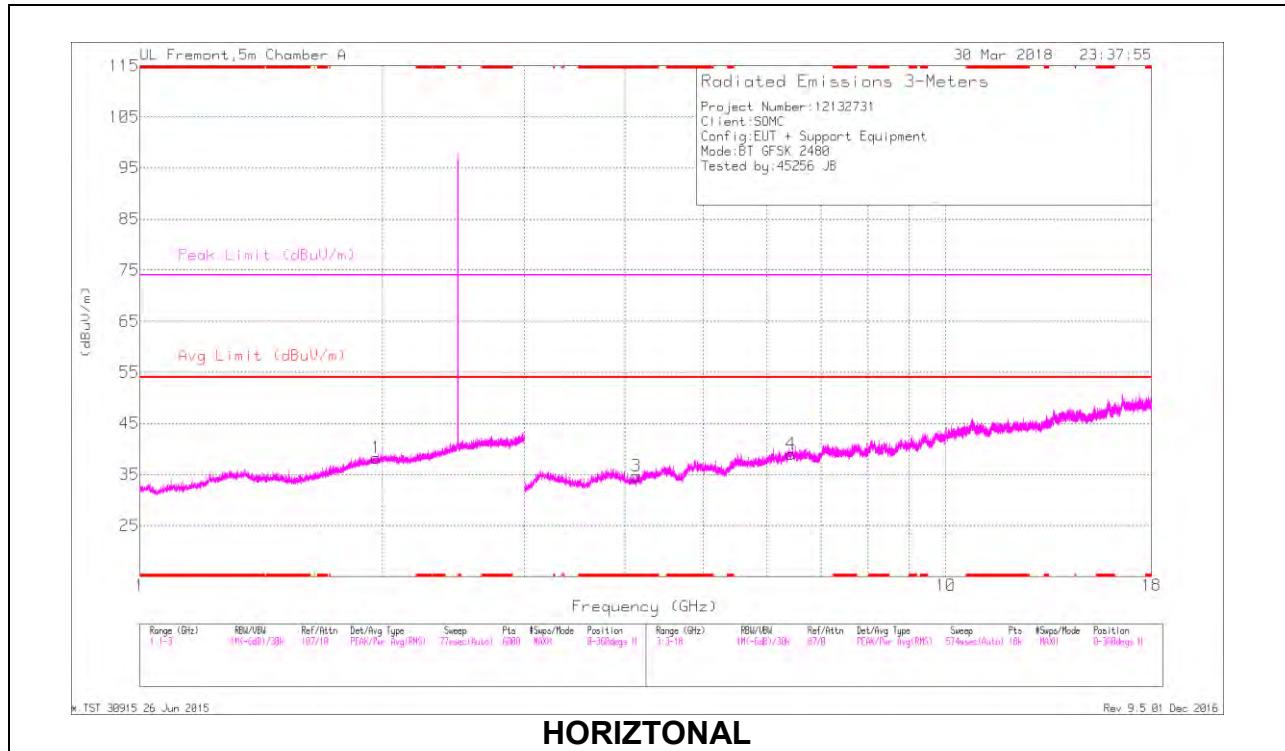

HORIZONTAL

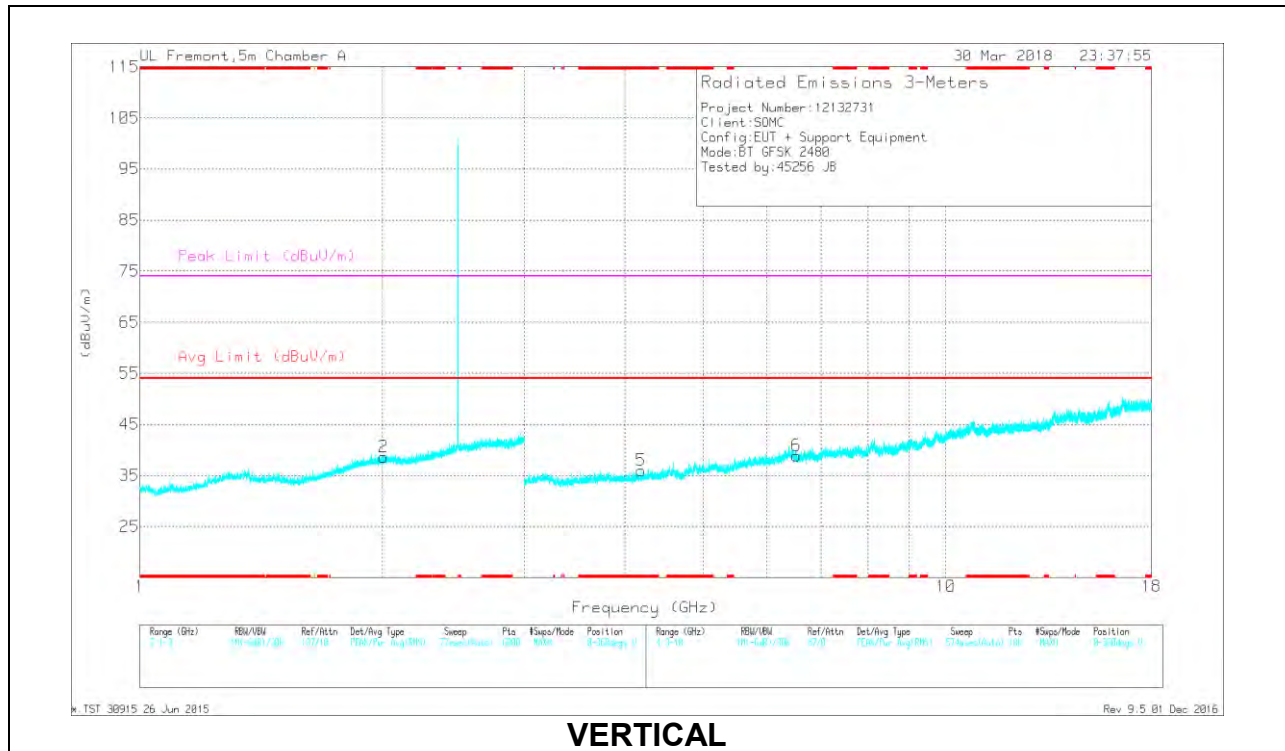

VERTICAL

RADIATED EMISSIONS

Trace Markers

Marker	Frequency (GHz)	Meter Reading (dBuV)	Det	AF T862 (dB/m)	Amp/Cbl/Filtr/Pad (dB)	Corrected Reading (dBuV/m)	Avg Limit (dBuV/m)	Margin (dB)	Peak Limit (dBuV/m)	PK Margin (dB)	Azimuth (Degs)	Height (cm)	Polarity
3	* 4.133	29.82	Pk	33.4	-28.5	34.72	-	-	74	-39.28	0-360	101	H
5	* 4.186	30.84	Pk	33.4	-28.3	35.94	-	-	74	-38.06	0-360	101	V
1	1.966	30.37	Pk	31.4	-23.5	38.27	-	-	-	-	0-360	101	H
2	2.005	30.71	Pk	31.4	-23.5	38.61	-	-	-	-	0-360	101	V
4	6.429	27.32	Pk	35.8	-24.1	39.02	-	-	-	-	0-360	199	H
6	6.521	27.17	Pk	35.7	-24	38.87	-	-	-	-	0-360	101	V

* - indicates frequency in CFR47 Pt 15 Restricted Band
 Pk - Peak detector

Radiated Emissions

Frequency (GHz)	Meter Reading (dBuV)	Det	AF T862 (dB/m)	Amp/Cbl/Filtr/Pad (dB)	Corrected Reading (dBuV/m)	Avg Limit (dBuV/m)	Margin (dB)	Peak Limit (dBuV/m)	PK Margin (dB)	Azimuth (Degs)	Height (cm)	Polarity
* 4.132	36.27	PKFH	33.4	-28.5	41.17	-	-	74	-32.83	238	108	H
* 4.135	23.61	VA1T	33.4	-28.5	28.51	54	-25.49	-	-	238	108	H
* 4.185	35.48	PKFH	33.4	-28.3	40.58	-	-	74	-33.42	230	102	V
* 4.187	23.53	VA1T	33.4	-28.3	28.63	54	-25.37	-	-	230	102	V

* - indicates frequency in CFR47 Pt 15 Restricted Band
 PKFH - FHSS: RB=100k/1MHz VB=3 x RB, Peak

9.1.2. BLUETOOTH ENHANCED DATA RATE 8PSK MODULATION

BANDEDGE (LOW CHANNEL)

HORIZONTAL RESULT

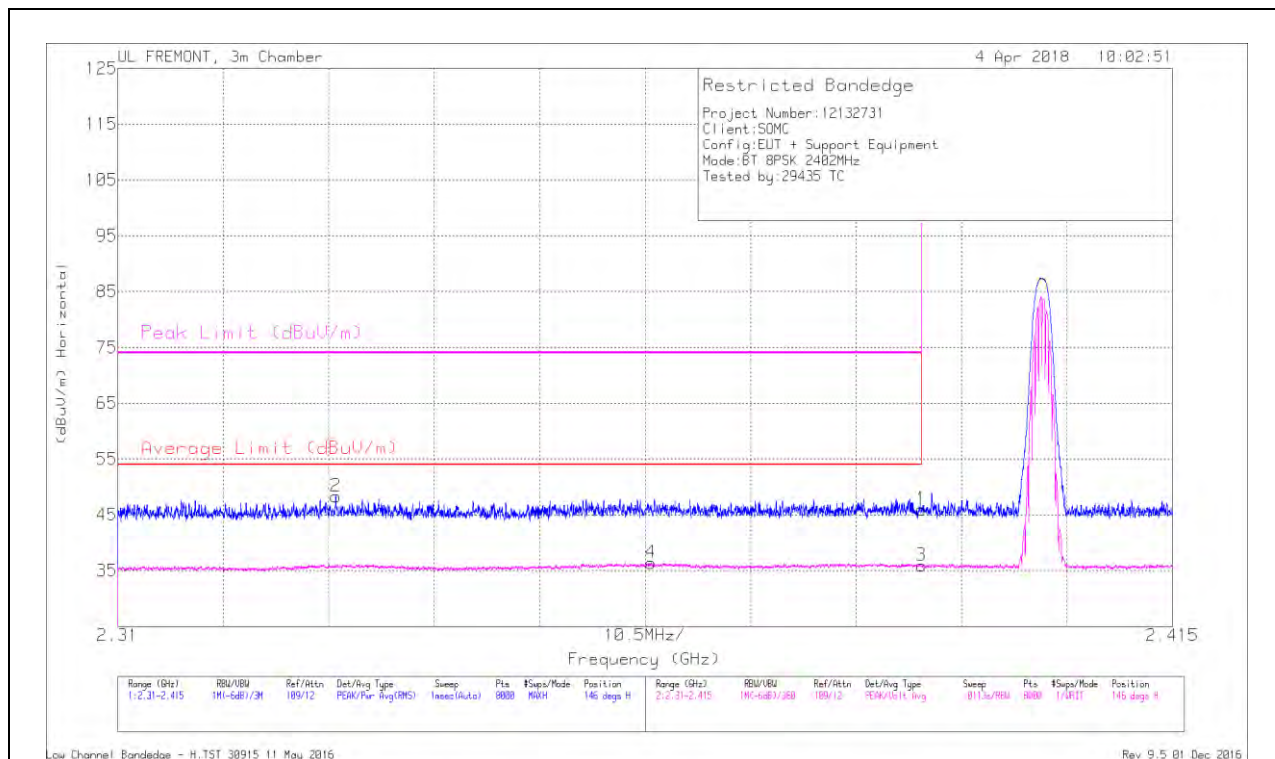

Marker	Frequency (GHz)	Meter Reading (dBuV)	Det	AF T120 (dB/m)	Amp/Cbl/Filtr/Pad (dB)	Corrected Reading (dBuV/m)	Average Limit (dBuV/m)	Margin (dB)	Peak Limit (dBuV/m)	PK Margin (dB)	Azimuth (Degs)	Height (cm)	Polarity
2	2.332	37.81	Pk	31.7	-21.2	48.31	-	-	74	-25.69	146	338	H
4	2.363	25.8	VA1T	31.7	-21.1	36.4	54	-17.6	-	-	146	338	H
1	2.39	35.43	Pk	31.9	-21.4	45.93	-	-	74	-28.07	146	338	H
3	2.39	25.4	VA1T	31.9	-21.4	35.9	54	-18.1	-	-	146	338	H

Pk - Peak detector

VA1T - FHSS: Linear Voltage Average $VB=1/Ton$ where: Ton is transmit duration

VERTICAL RESULT

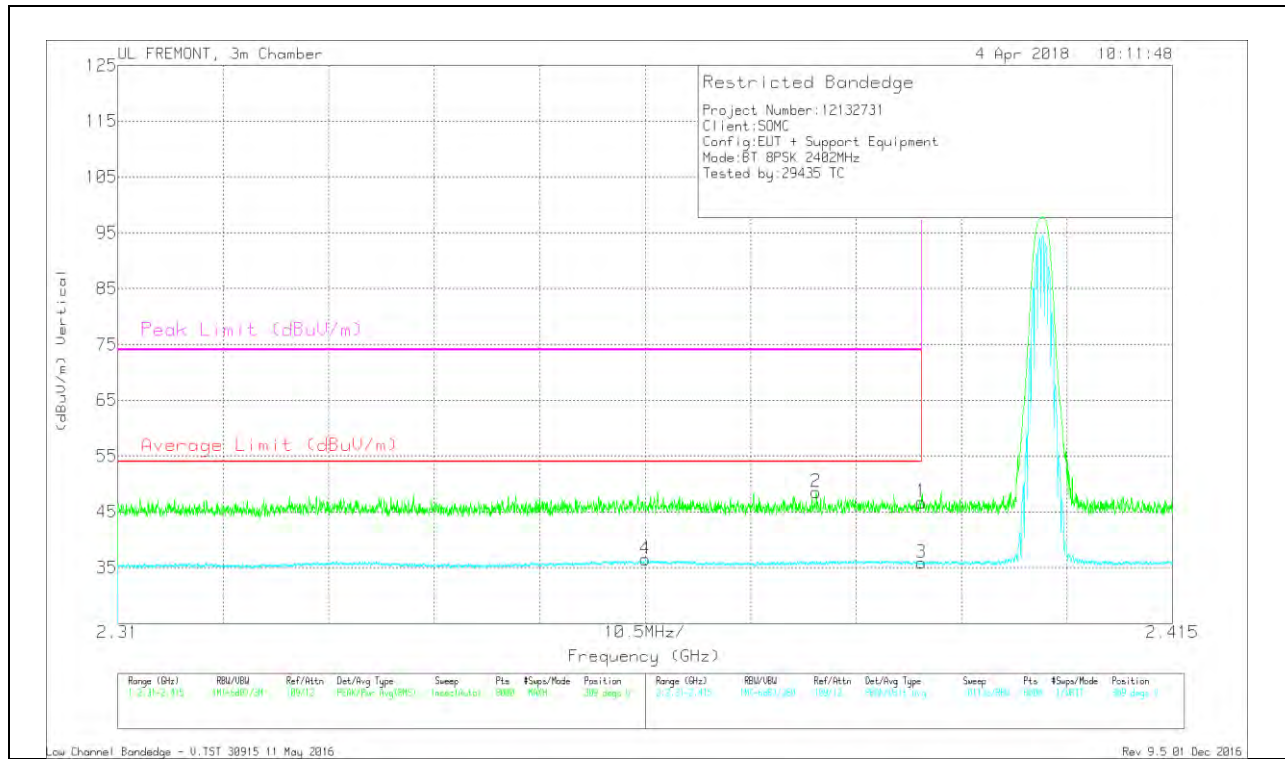

Marker	Frequency (GHz)	Meter Reading (dBuV)	Det	AF T120 (dB/m)	Amp/Cbl/Filtr/Pad (dB)	Corrected Reading (dBuV/m)	Average Limit (dBuV/m)	Margin (dB)	Peak Limit (dBuV/m)	PK Margin (dB)	Azimuth (Degs)	Height (cm)	Polarity
4	2.363	25.92	VA1T	31.7	-21.1	36.52	54	-17.48	-	-	309	228	V
2	2.38	38.21	PK	31.8	-21.4	48.61	-	-	74	-25.39	309	228	V
1	2.39	36.25	PK	31.9	-21.4	46.75	-	-	74	-27.25	309	228	V
3	2.39	25.38	VA1T	31.9	-21.4	35.88	54	-18.12	-	-	309	228	V

Pk - Peak detector

VA1T - FHSS: Linear Voltage Average $V_B=1/T_{on}$ where: T_{on} is transmit duration

BANDEDGE (HIGH CHANNEL)

HORIZONTAL RESULT

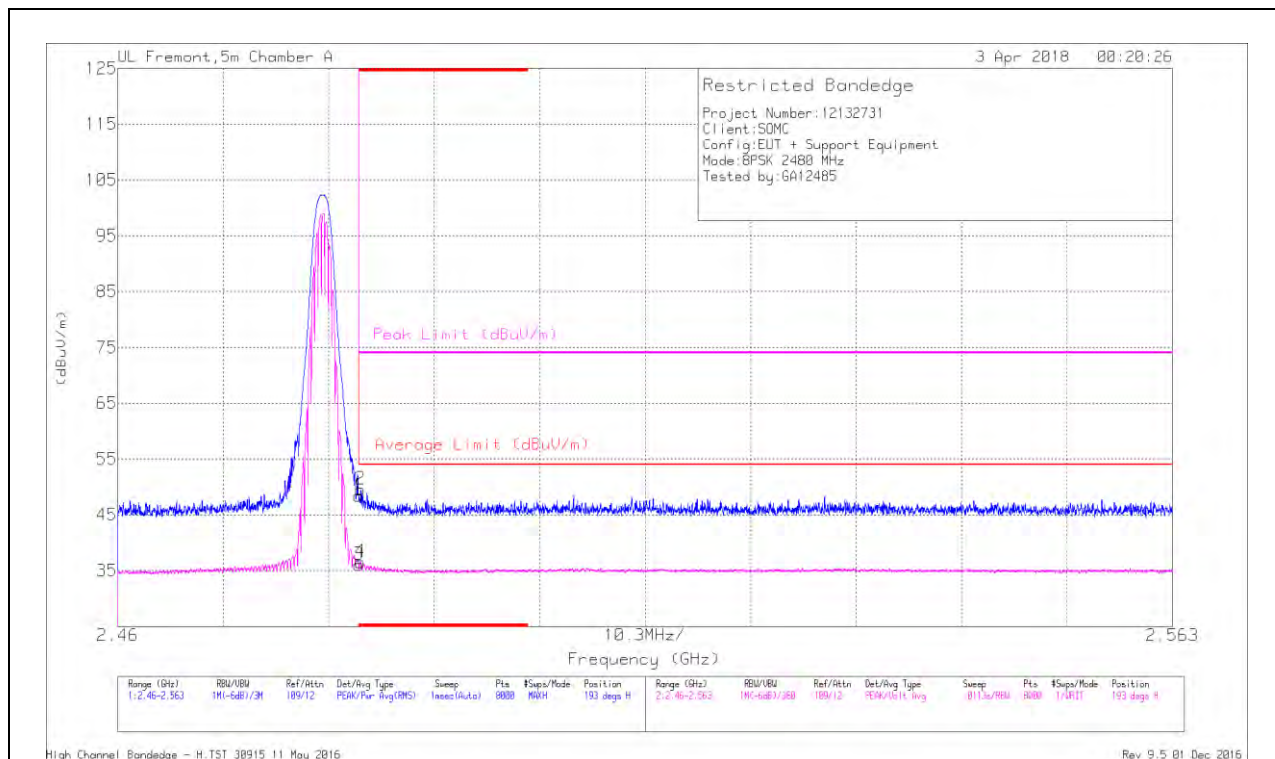

Marker	Frequency (GHz)	Meter Reading (dBuV)	Det	AF T862 (dB/m)	Amp/Cbl/Fitr/P ad (dB)	Corrected Reading (dBuV/m)	Average Limit (dBuV/m)	Margin (dB)	Peak Limit (dBuV/m)	PK Margin (dB)	Azimuth (Degs)	Height (cm)	Polarity
1	* 2.484	39.56	Pk	32.3	-23.4	48.46	-	-	74	-25.54	193	108	H
2	* 2.484	40.67	Pk	32.3	-23.4	49.57	-	-	74	-24.43	193	108	H
3	* 2.484	27.14	VA1T	32.3	-23.4	36.04	54	-17.96	-	-	193	108	H
4	* 2.484	27.66	VA1T	32.3	-23.4	36.56	54	-17.44	-	-	193	108	H

* - indicates frequency in CFR47 Pt 15 Restricted Band
 Pk - Peak detector
 VA1T - FHSS: Linear Voltage Average VB=1/Ton where: Ton is transmit duration

VERTICAL RESULT

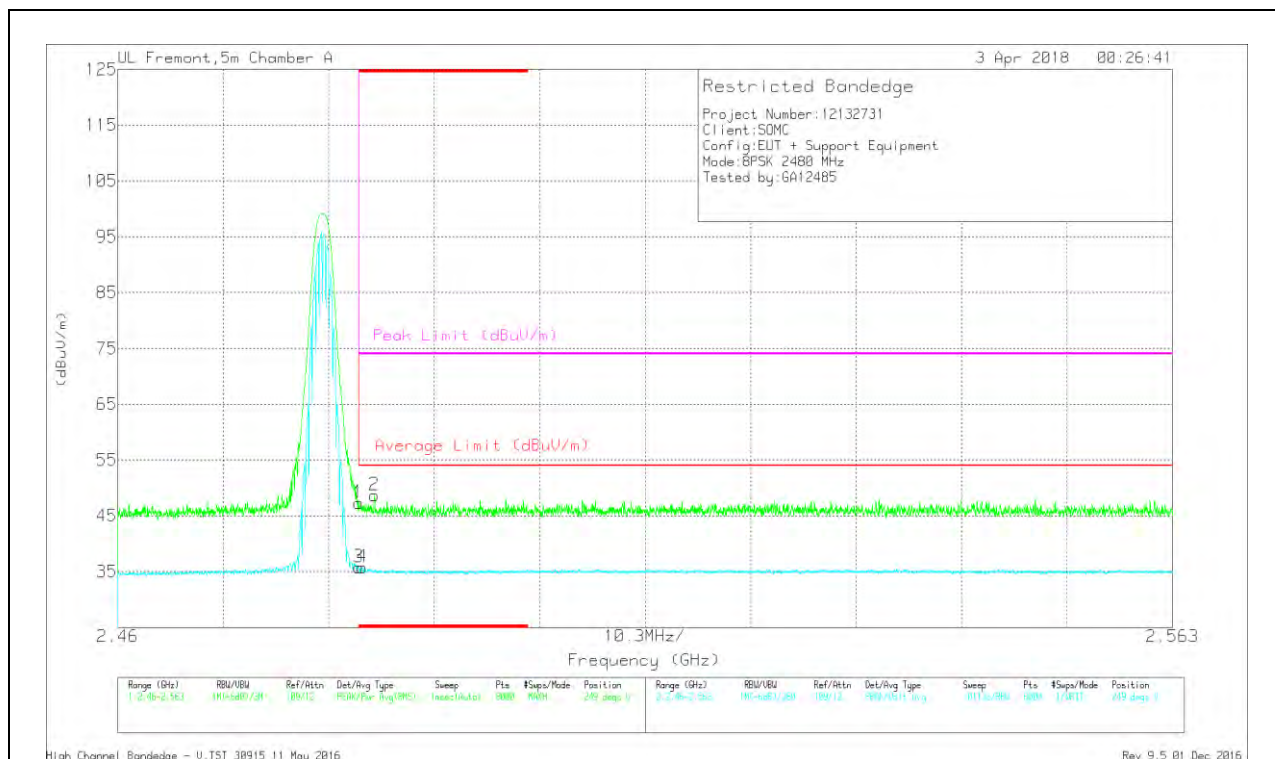

Marker	Frequency (GHz)	Meter Reading (dBuV)	Det	AF T862 (dB/m)	Amp/Cbl/Fitr/P ad (dB)	Corrected Reading (dBuV/m)	Average Limit (dBuV/m)	Margin (dB)	Peak Limit (dBuV/m)	PK Margin (dB)	Azimuth (Degs)	Height (cm)	Polarity
1	* 2.484	38.39	Pk	32.3	-23.4	47.29	-	-	74	-26.71	249	311	V
2	* 2.485	39.78	Pk	32.3	-23.4	48.68	-	-	74	-25.32	249	311	V
3	* 2.484	26.84	VA1T	32.3	-23.4	35.74	54	-18.26	-	-	249	311	V
4	* 2.484	26.9	VA1T	32.3	-23.4	35.8	54	-18.2	-	-	249	311	V

* - indicates frequency in CFR47 Pt 15 Restricted Band

Pk - Peak detector

VA1T - FHSS: Linear Voltage Average $V_B=1/T_{on}$ where: T_{on} is transmit duration

HARMONICS AND SPURIOUS EMISSIONS

LOW CHANNEL RESULTS

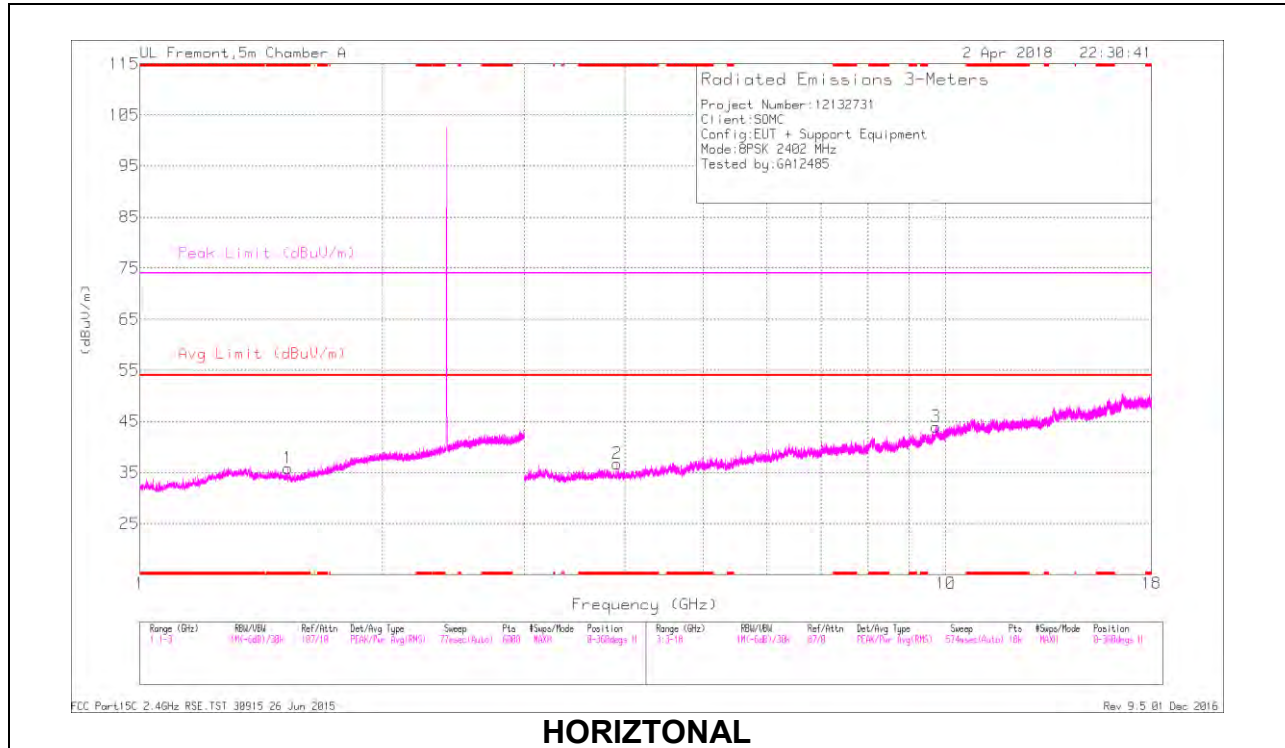

HORIZONTAL

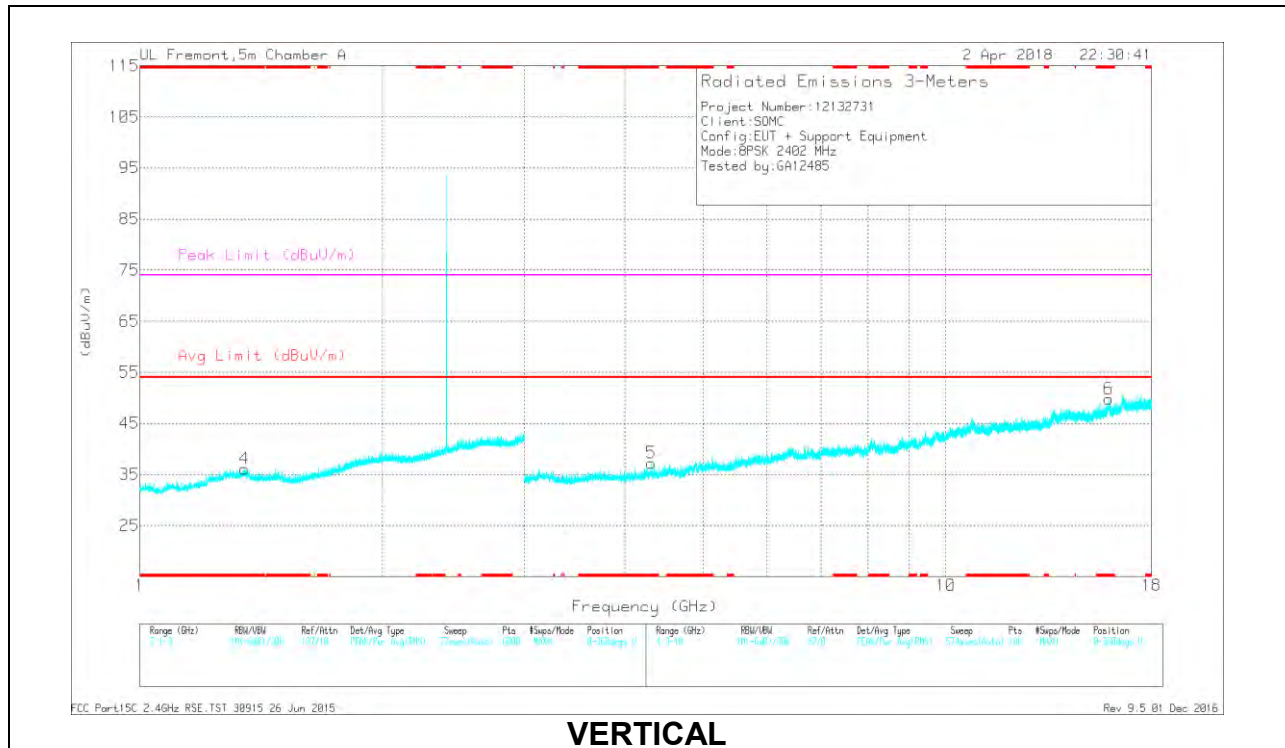

VERTICAL

Trace Markers

Marker	Frequency (GHz)	Meter Reading (dBuV)	Det	AF T862 (dB/m)	Amp/Cbl/Filtr/Pad (dB)	Corrected Reading (dBuV/m)	Avg Limit (dBuV/m)	Margin (dB)	Peak Limit (dBuV/m)	PK Margin (dB)	Azimuth (Degs)	Height (cm)	Polarity
1	* 1.527	31.33	Pk	28.1	-23.6	35.83	-	-	74	-38.17	0-360	199	H
4	* 1.349	30.27	Pk	29.5	-23.7	36.07	-	-	74	-37.93	0-360	101	V
2	* 3.908	32.24	Pk	33.1	-28.6	36.74	-	-	74	-37.26	0-360	199	H
5	* 4.31	31.28	Pk	33.6	-27.7	37.18	-	-	74	-36.82	0-360	101	V
6	* 15.928	26.25	Pk	40.3	-16.8	49.75	-	-	74	-24.25	0-360	101	V
3	9.729	26.7	Pk	36.9	-19.6	44	-	-	-	-	0-360	199	H

* - indicates frequency in CFR47 Pt 15 Restricted Band
 Pk - Peak detector

Radiated Emissions

Frequency (GHz)	Meter Reading (dBuV)	Det	AF T862 (dB/m)	Amp/Cbl/Filtr/Pad (dB)	Corrected Reading (dBuV/m)	Avg Limit (dBuV/m)	Margin (dB)	Peak Limit (dBuV/m)	PK Margin (dB)	Azimuth (Degs)	Height (cm)	Polarity
* 1.527	34.56	PKFH	28.1	-23.6	39.06	-	-	74	-34.94	201	206	H
* 1.525	23.55	VA1T	28.1	-23.6	28.05	54	-25.95	-	-	201	206	H
* 1.349	34.18	PKFH	29.5	-23.7	39.98	-	-	74	-34.02	24	369	V
* 1.349	23.45	VA1T	29.5	-23.7	29.25	54	-24.75	-	-	24	369	V
* 3.91	35.32	PKFH	33.2	-28.6	39.92	-	-	74	-34.08	26	258	H
* 3.91	24.78	VA1T	33.1	-28.6	29.28	54	-24.72	-	-	26	258	H
* 4.31	34.63	PKFH	33.6	-27.7	40.53	-	-	74	-33.47	183	166	V
* 4.31	24.1	VA1T	33.6	-27.7	30	54	-24	-	-	183	166	V
* 15.928	30.42	PKFH	40.3	-16.8	53.92	-	-	74	-20.08	268	131	V
* 15.927	19.3	VA1T	40.3	-16.9	42.7	54	-11.3	-	-	268	131	V

* - indicates frequency in CFR47 Pt 15 Restricted Band
 PKFH - FHSS: RB=100k/1MHz VB=3 x RB, Peak

MID CHANNEL RESULTS

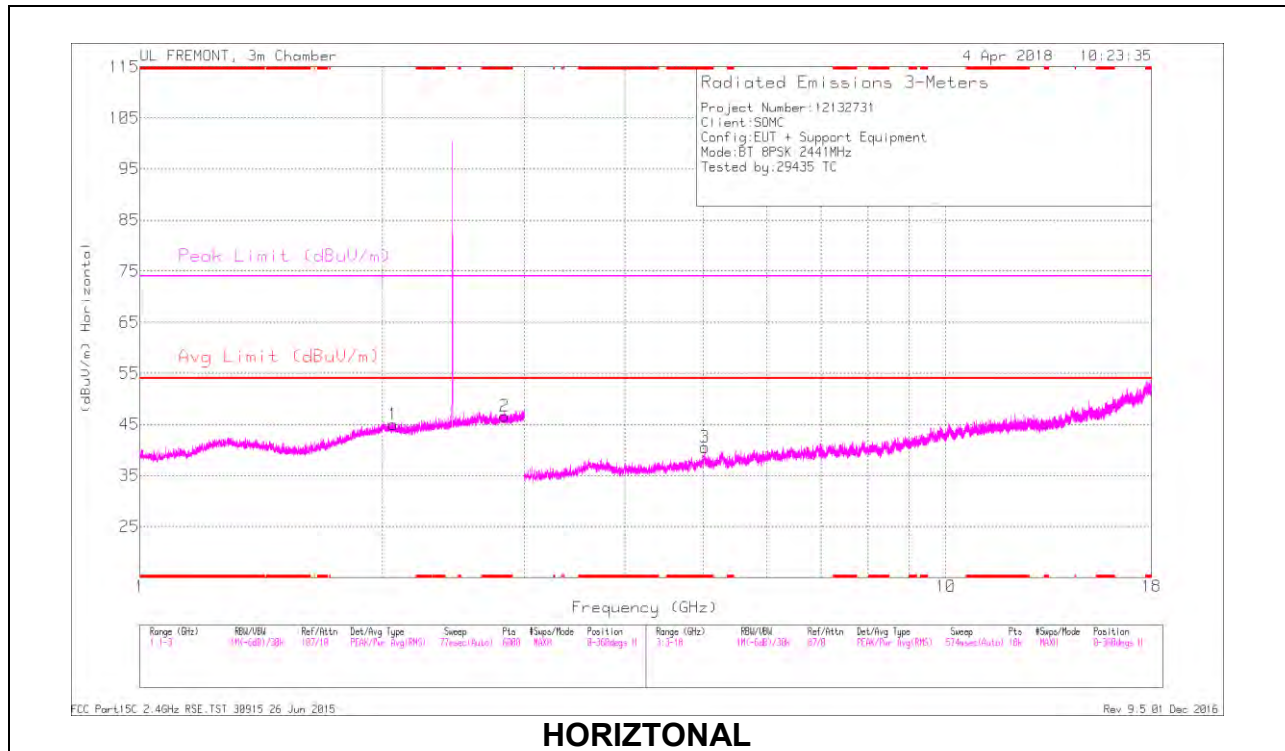

HORIZONTAL

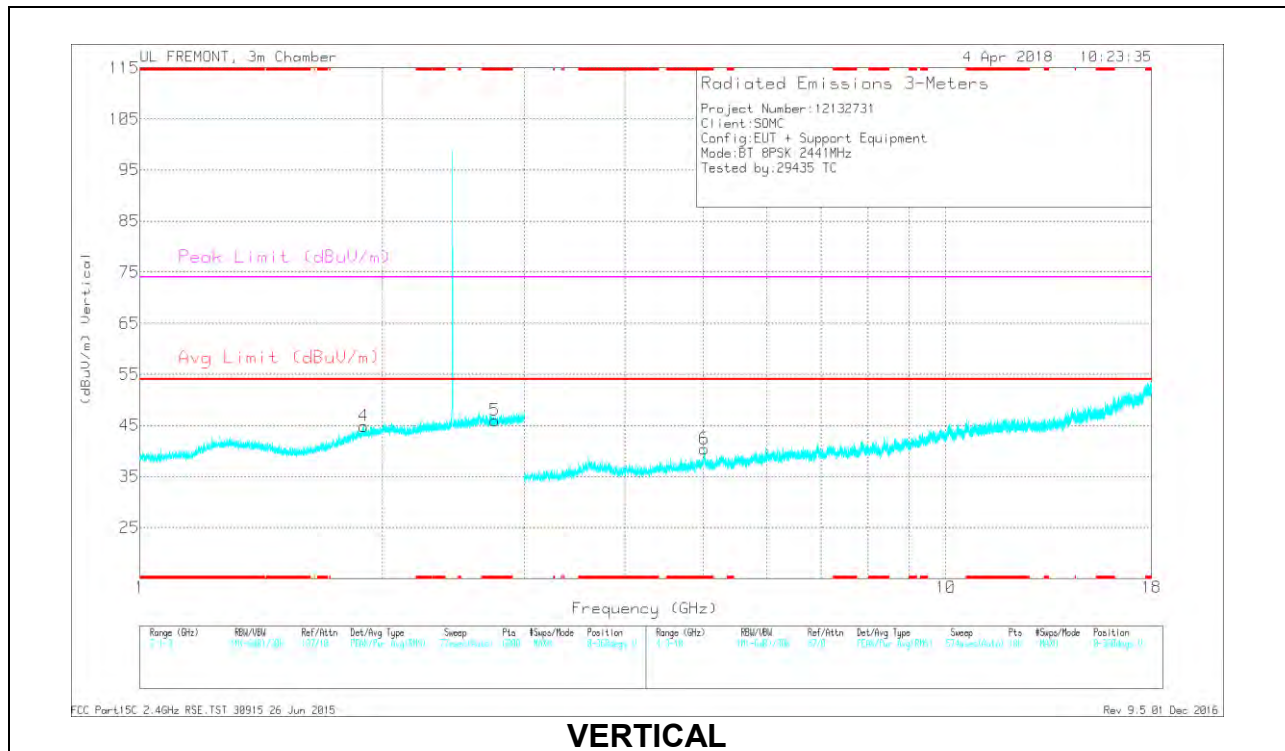

VERTICAL

RADIATED EMISSIONS

Trace Markers

Marker	Frequency (GHz)	Meter Reading (dBuV)	Det	AF T120 (dB/m)	Amp/Cbl/Filtr/Pad (dB)	Corrected Reading (dBuV/m)	Avg Limit (dBuV/m)	Margin (dB)	Peak Limit (dBuV/m)	PK Margin (dB)	Azimuth (Degs)	Height (cm)	Polarity
2	* 2.836	34.46	Pk	32.7	-20.5	46.66	-	-	74	-27.34	0-360	200	H
5	* 2.756	33.88	Pk	32.5	-20.4	45.98	-	-	74	-28.02	0-360	100	V
3	* 5.023	31.06	Pk	34.2	-24.7	40.56	-	-	74	-33.44	0-360	100	H
6	* 5.018	30.65	Pk	34.2	-24.5	40.35	-	-	74	-33.65	0-360	100	V
4	1.894	34.8	Pk	31.3	-21.3	44.8	-	-	-	-	0-360	200	V
1	2.061	34.18	Pk	31.8	-21	44.98	-	-	-	-	0-360	100	H

* - indicates frequency in CFR47 Pt 15 Restricted Band
 Pk - Peak detector

Radiated Emissions

Frequency (GHz)	Meter Reading (dBuV)	Det	AF T120 (dB/m)	Amp/Cbl/Filtr/Pad (dB)	Corrected Reading (dBuV/m)	Avg Limit (dBuV/m)	Margin (dB)	Peak Limit (dBuV/m)	PK Margin (dB)	Azimuth (Degs)	Height (cm)	Polarity
* 2.835	38.5	PKFH	32.7	-20.5	50.7	-	-	74	-23.3	88	350	H
* 2.835	27.88	VA1T	32.7	-20.4	40.18	54	-13.82	-	-	88	350	H
* 2.754	38.57	PKFH	32.5	-20.5	50.57	-	-	74	-23.43	257	311	V
* 2.754	27.86	VA1T	32.5	-20.5	39.86	54	-14.14	-	-	257	311	V
* 5.025	34.94	PKFH	34.2	-25.3	43.84	-	-	74	-30.16	324	255	H
* 5.025	24.26	VA1T	34.2	-25	33.46	54	-20.54	-	-	324	255	H
* 5.019	34.92	PKFH	34.2	-24.3	44.82	-	-	74	-29.18	44	293	V
* 5.02	23.97	VA1T	34.2	-24.3	33.87	54	-20.13	-	-	44	293	V

* - indicates frequency in CFR47 Pt 15 Restricted Band
 PKFH - FHSS: RB=100k/1MHz VB=3 x RB, Peak

HIGH CHANNEL RESULTS

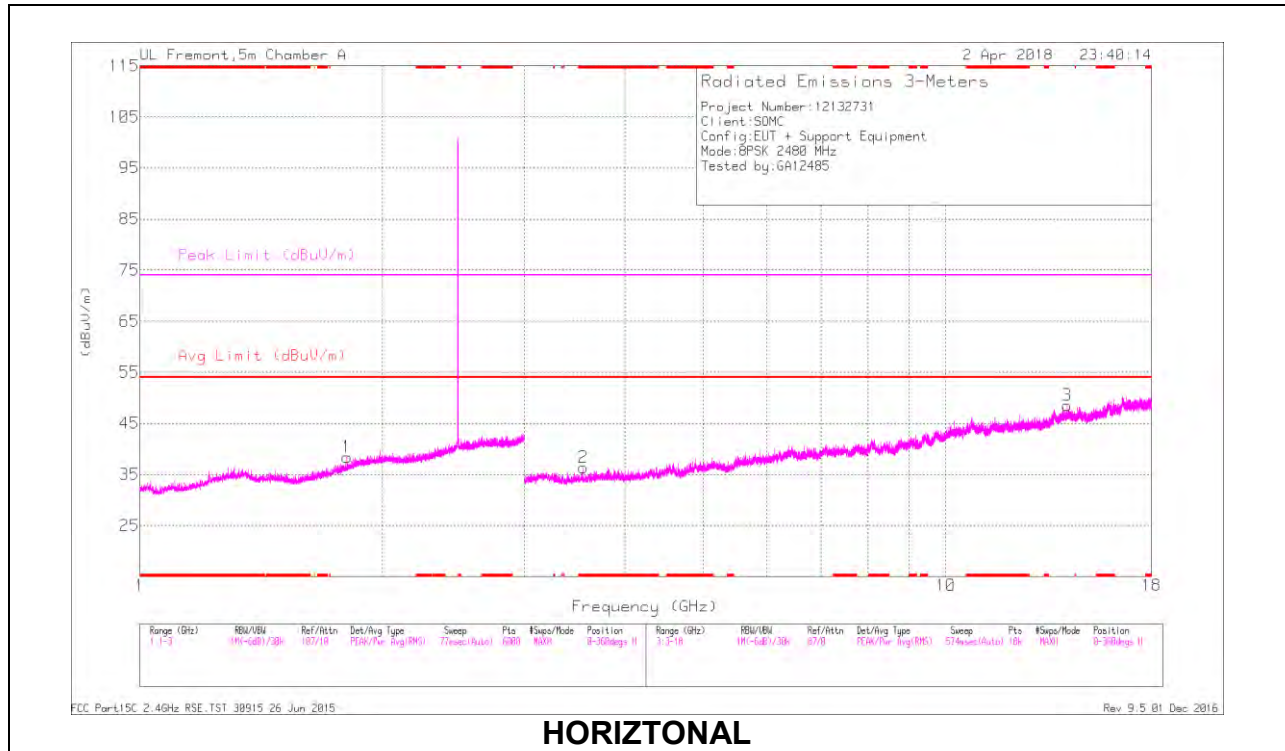

HORIZONTAL

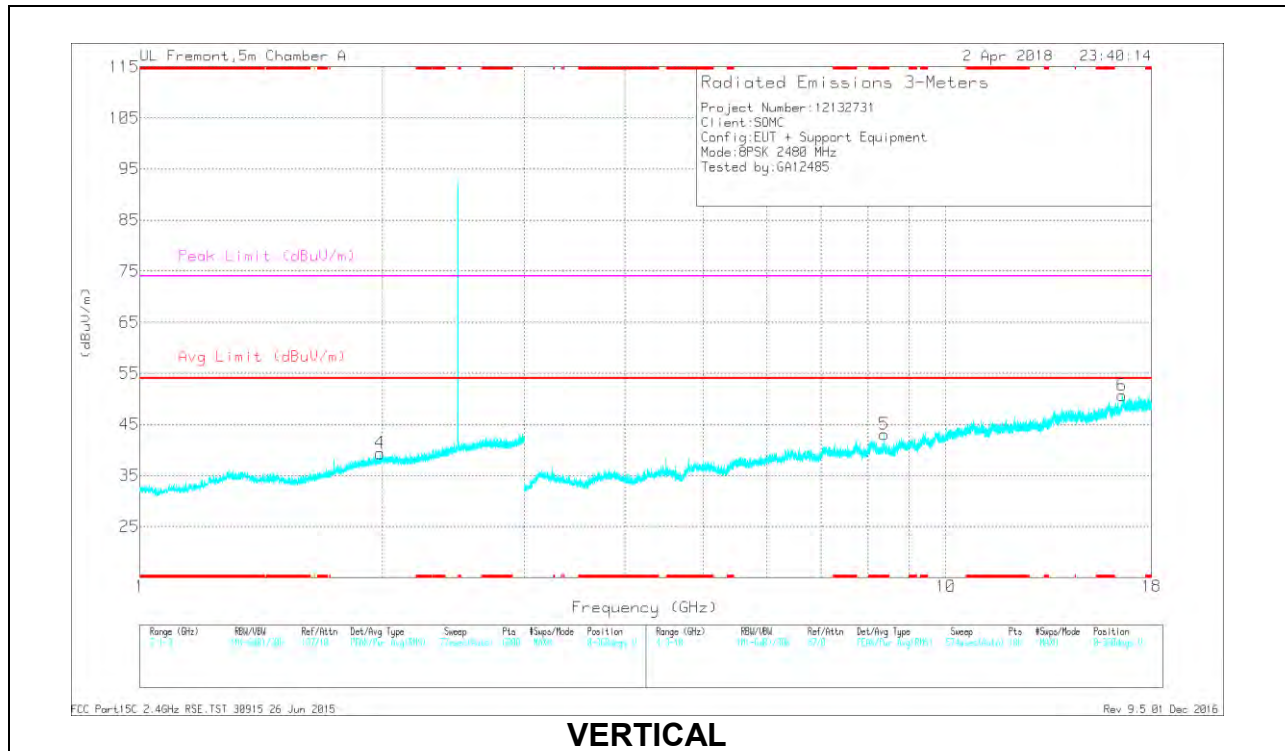

VERTICAL

Trace Markers

Marker	Frequency (GHz)	Meter Reading (dBuV)	Det	AF T862 (dB/m)	Amp/Cbl/Filtr/Pad (dB)	Corrected Reading (dBuV/m)	Avg Limit (dBuV/m)	Margin (dB)	Peak Limit (dBuV/m)	PK Margin (dB)	Azimuth (Degs)	Height (cm)	Polarity
2	* 3.55	32.25	Pk	33	-28.9	36.35	-	-	74	-37.65	0-360	199	H
5	* 8.382	28.98	Pk	35.8	-21.7	43.08	-	-	74	-30.92	0-360	200	V
1	1.808	31.48	Pk	30.3	-23.4	38.38	-	-	-	-	0-360	102	H
4	1.984	31.42	Pk	31.4	-23.5	39.32	-	-	-	-	0-360	101	V
3	14.144	27.93	Pk	39.5	-18.9	48.53	-	-	-	-	0-360	199	H
6	16.547	26.31	Pk	41.3	-16.9	50.71	-	-	-	-	0-360	101	V

* - indicates frequency in CFR47 Pt 15 Restricted Band

Pk - Peak detector

Radiated Emissions

Frequency (GHz)	Meter Reading (dBuV)	Det	AF T862 (dB/m)	Amp/Cbl/Filtr/Pad (dB)	Corrected Reading (dBuV/m)	Avg Limit (dBuV/m)	Margin (dB)	Peak Limit (dBuV/m)	PK Margin (dB)	Azimuth (Degs)	Height (cm)	Polarity
* 3.549	35.82	PKFH	33	-28.9	39.92	-	-	74	-34.08	217	383	H
* 3.549	24.54	VA1T	33	-28.9	28.64	54	-25.36	-	-	217	383	H
* 8.381	32.5	PKFH	35.8	-21.7	46.6	-	-	74	-27.4	67	106	V
* 8.381	21.12	VA1T	35.8	-21.7	35.22	54	-18.78	-	-	67	106	V

* - indicates frequency in CFR47 Pt 15 Restricted Band

PKFH - FHSS: RB=100k/1MHz VB=3 x RB, Peak

9.2. SPURIOUS EMISSIONS BELOW 30 MHz (WORST-CASE CONFIGURATION)

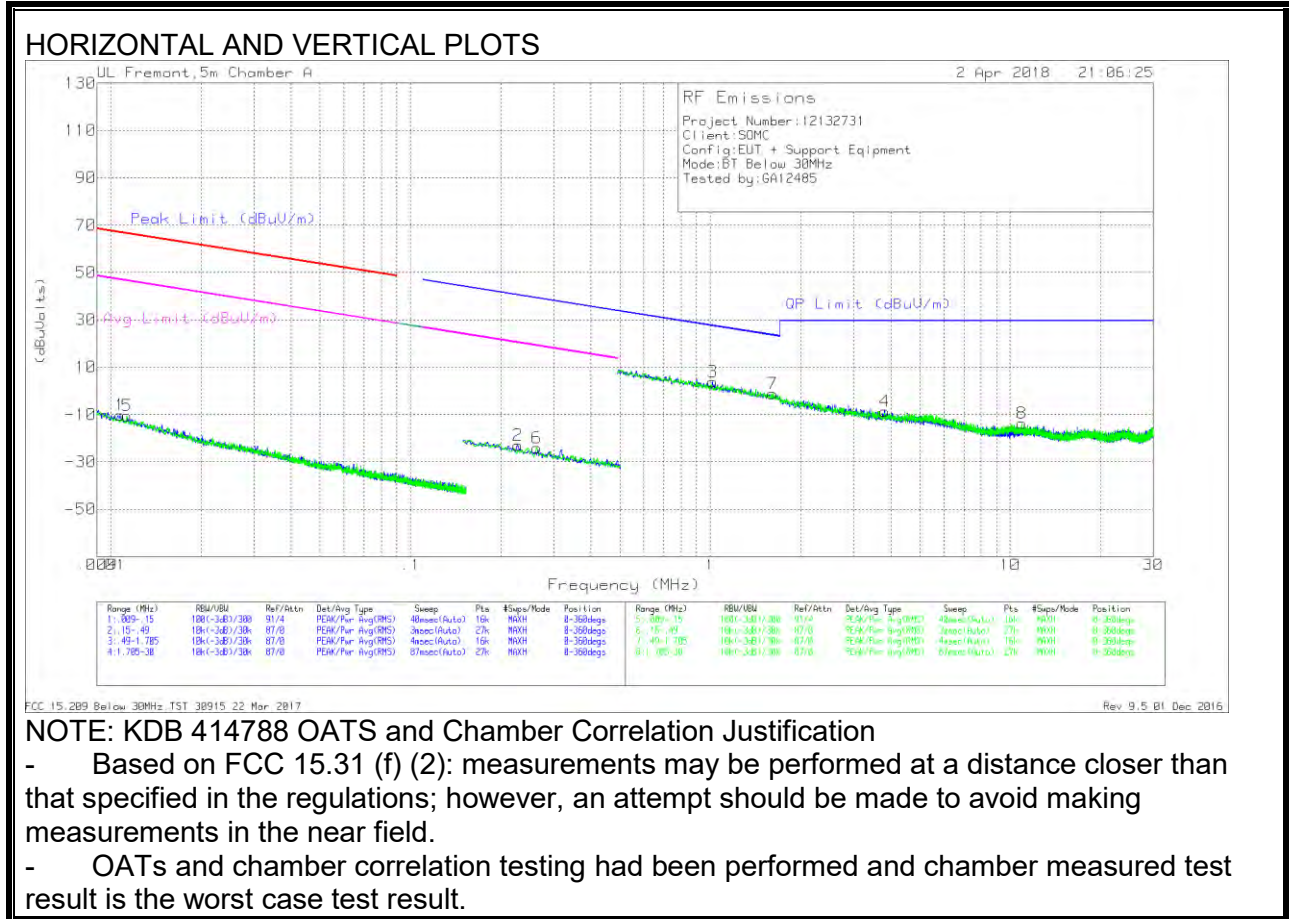

Trace Markers

Marker	Frequency (MHz)	Meter Reading (dBuV)	Det	Loop Antenna (dB/m)	ChI (dB)	Dist Corr 30m	Corrected Reading (dBuV)	Peak Limit (dBuV/m)	Margin (dB)	Avg Limit (dBuV/m)	Margin (dB)	Peak Limit (dBuV/m)	Margin (dB)	Avg Limit (dBuV/m)	Margin (dB)	Azimuth (Deg)
1	.01075	51.23	Pk	18.4	.1	-80	-10.27	66.96	-77.23	46.96	-57.23	-	-	-	-	0-360
5	.01132	51.28	Pk	18.1	.1	-80	-10.52	66.51	-77.03	46.51	-57.03	-	-	-	-	0-360
2	.22803	45.81	Pk	11	.1	-80	-23.09	-	-	-	-	40.46	-63.55	20.46	-43.55	0-360
6	.26354	44.95	Pk	10.9	.1	-80	-24.05	-	-	-	-	39.2	-63.25	19.2	-43.25	0-360

Pk - Peak detector

Marker	Frequency (MHz)	Meter Reading (dBuV)	Det	Loop Antenna (dB/m)	ChI (dB)	Dist Corr 30m	Corrected Reading (dBuV)	Margin In (dB)	OP Limit (dBuV/m)	Margin (dB)	Margin In (dB)	Azimuth (Deg)
3	1.01702	32.37	Pk	11.3	.2	-40	3.87	-	27.48	-23.61	-	0-360
7	1.61374	27.28	Pk	11.4	.2	-40	-1.12	-	23.48	-24.6	-	0-360
4	3.81253	19.82	Pk	11.3	.3	-40	-8.58	-	29.5	-38.08	-	0-360
8	10.9536	14.65	Pk	11.1	.5	-40	-13.75	-	29.5	-43.25	-	0-360

Pk - Peak detector

9.3. WORST-CASE BELOW 1 GHz

SPURIOUS EMISSIONS 30 TO 1000 MHz (WORST-CASE CONFIGURATION)

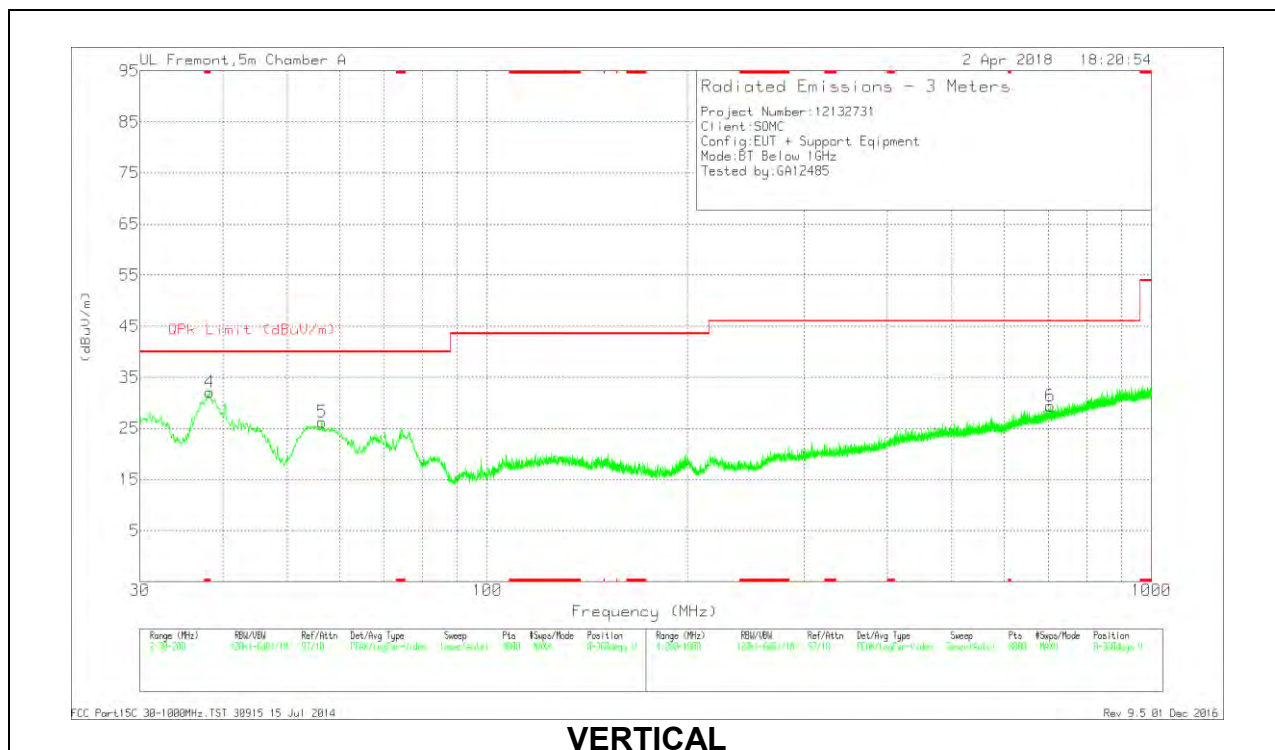
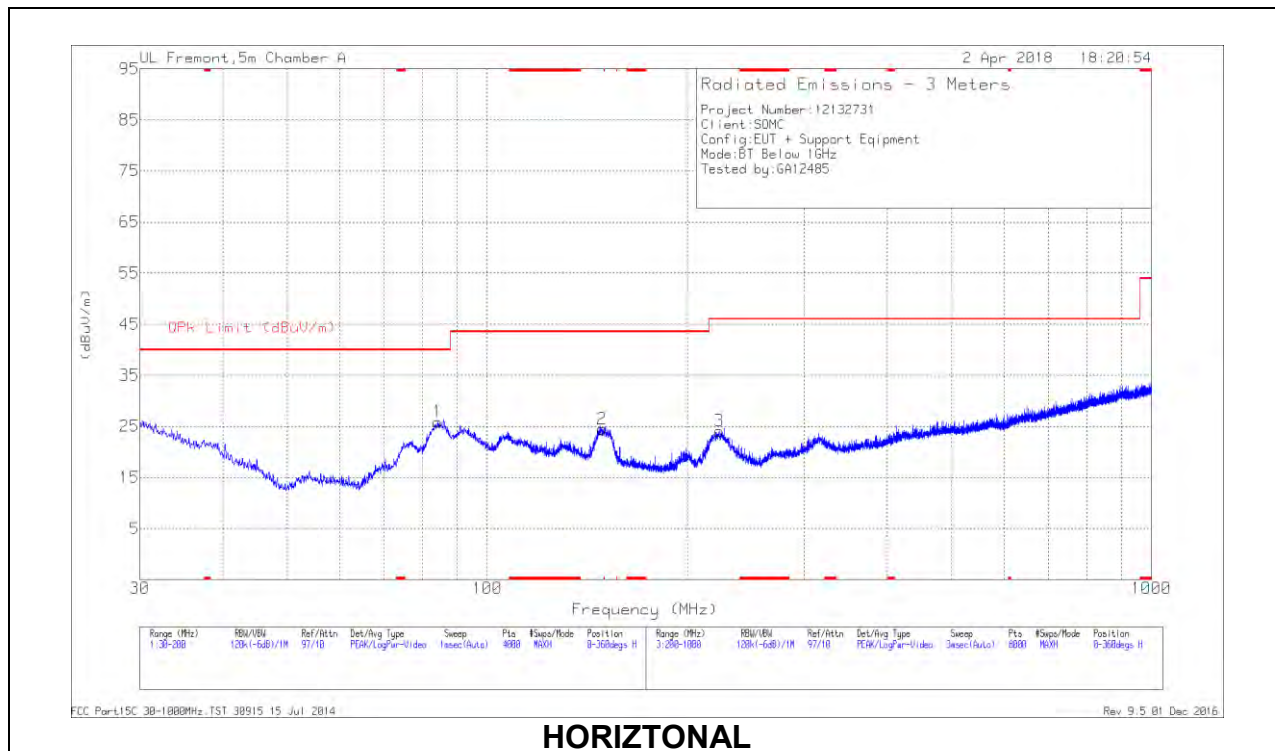

Below 1GHz Data

Marker	Frequency (MHz)	Meter Reading (dBuV)	Det	AF T130 (dB/m)	Amp/Cbl (dB/m)	Corrected Reading (dBuV/m)	QPk Limit (dBuV/m)	Margin (dB)	Azimuth (Degs)	Height (cm)	Polarity
4	* 38.2259	40.03	Pk	19.2	-27.2	32.03	40	-7.97	0-360	100	V
5	56.3993	42.03	Pk	11.1	-26.9	26.23	40	-13.77	0-360	100	V
1	84.2865	41.12	Pk	11.3	-26.6	25.82	40	-14.18	0-360	200	H
2	148.7757	33.9	Pk	16.5	-25.9	24.5	43.52	-19.02	0-360	100	H
3	223.403	34.45	Pk	14.7	-25.1	24.05	46.02	-21.97	0-360	101	H
6	704.6656	29.54	Pk	24.3	-24.4	29.44	46.02	-16.58	0-360	101	V

* - indicates frequency in CFR47 Pt 15 Restricted Band

Pk - Peak detector

9.4. WORST-CASE 18-26 GHz

SPURIOUS EMISSIONS 18-26 GHz (WORST-CASE CONFIGURATION)

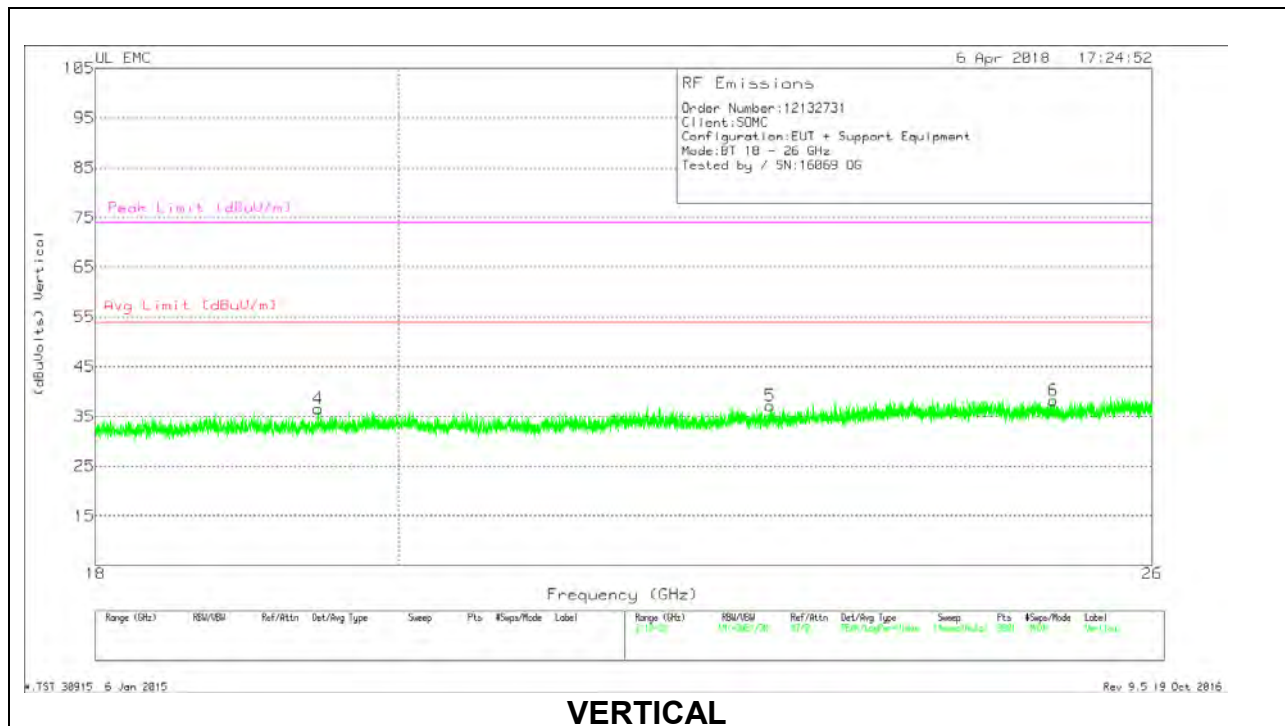
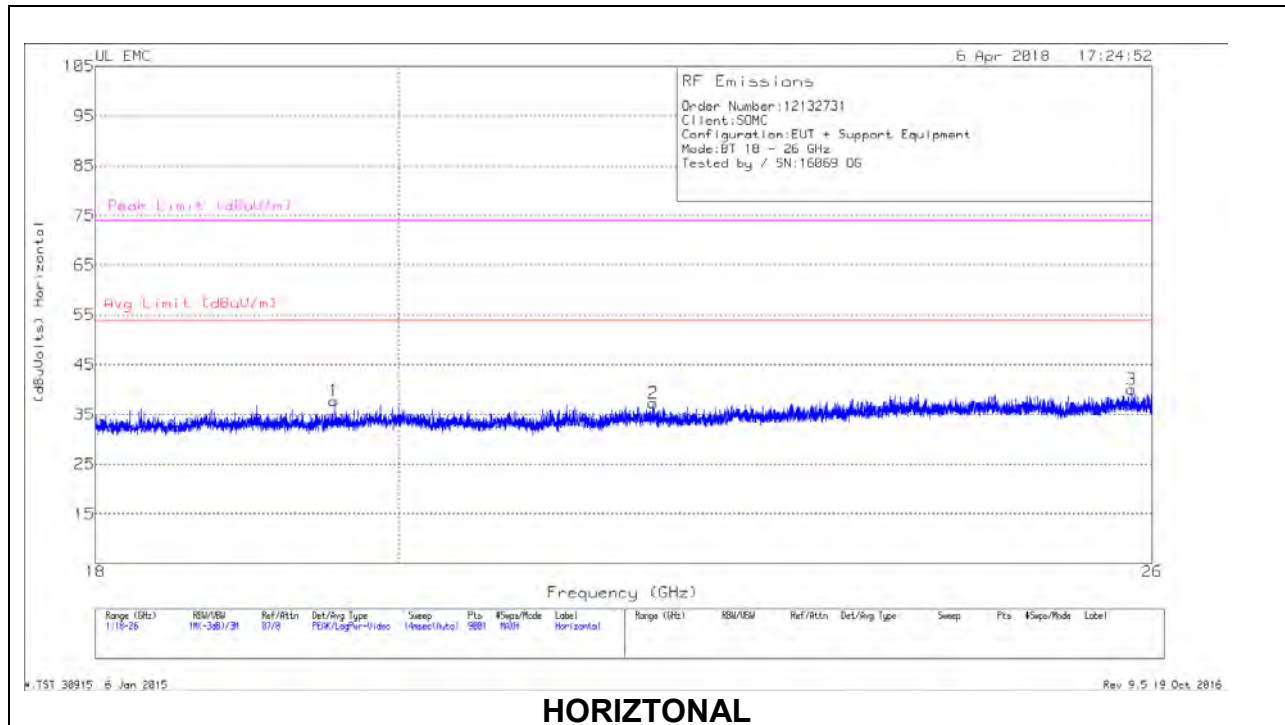

18 – 26GHz DATA

Marker	Frequency (GHz)	Meter Reading (dBuV)	Det	T89 AF (dB/m)	Amp/Cbl (dB)	Dist Corr (dB)	Corrected Reading (dBuVolts)	Avg Limit (dBuV/m)	Margin (dB)	Peak Limit (dBuV/m)	PK Margin (dB)
1	19.559	39.84	Pk	32.5	-25.1	-9.5	37.74	54	-16.26	74	-36.26
2	21.857	38.07	Pk	33.3	-24.6	-9.5	37.27	54	-16.73	74	-36.73
3	25.814	40.3	Pk	34.1	-24.9	-9.5	40	54	-14	74	-34
4	19.451	38.12	Pk	32.5	-24.6	-9.5	36.52	54	-17.48	74	-37.48
5	22.762	38.15	Pk	33.2	-24.7	-9.5	37.15	54	-16.85	74	-36.85
6	25.12	38.41	Pk	33.9	-24.6	-9.5	38.21	54	-15.79	74	-35.79

Pk - Peak detector

10. AC POWER LINE CONDUCTED EMISSIONS

LIMITS

FCC §15.207 (a)

Frequency of Emission (MHz)	Conducted Limit (dBuV)	
	Quasi-peak	Average
0.15-0.5	66 to 56*	56 to 46*
0.5-5	56	46
5-30	60	50

*Decreases with the logarithm of the frequency.

TEST PROCEDURE

The EUT is placed on a non-conducting table 40 cm from the vertical ground plane and 80 cm above the horizontal ground plane. The EUT is configured in accordance with ANSI C63.4.

The receiver is set to a resolution bandwidth of 9 kHz. Peak detection is used unless otherwise noted as quasi-peak or average.

Line conducted data is recorded for both NEUTRAL and HOT lines.

RESULTS

LINE 1 RESULTS

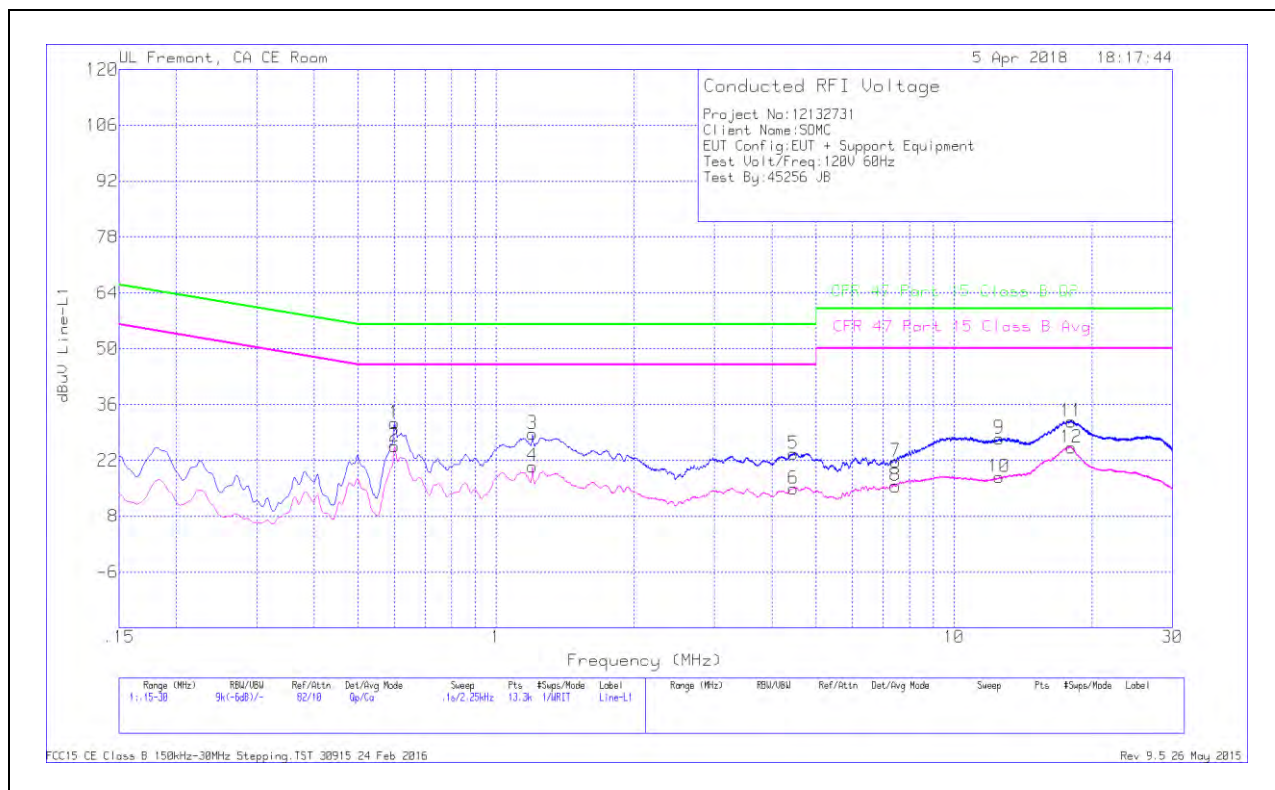

Range 1: Line-L1 .15 - 30MHz

Marker	Frequency (MHz)	Meter Reading (dBuV)	Det	LISN L1	LC Cables C1&C3	Limiter (dB)	Corrected Reading dBuV	CFR 47 Part 15 Class B QP	QP Margin (dB)	CFR 47 Part 15 Class B Avg	Av(CISPR)Margin (dB)
1	.6	21.24	Qp	0	0	10.1	31.34	56	-24.66	-	-
2	.6	15.49	Ca	0	0	10.1	25.59	-	-	46	-20.41
3	1.20075	18.46	Qp	0	.1	10.1	28.66	56	-27.34	-	-
4	1.20075	10.3	Ca	0	.1	10.1	20.5	-	-	46	-25.5
5	4.45763	13.47	Qp	0	.1	10.1	23.67	56	-32.33	-	-
6	4.45763	4.75	Ca	0	.1	10.1	14.95	-	-	46	-31.05
7	7.4535	11.28	Qp	0	.2	10.2	21.68	60	-38.32	-	-
8	7.44675	5.17	Ca	0	.2	10.2	15.57	-	-	50	-34.43
9	12.5587	16.99	Qp	.1	.2	10.2	27.49	60	-32.51	-	-
10	12.5565	7.32	Ca	.1	.2	10.2	17.82	-	-	50	-32.18
11	18.0397	21.13	Qp	0	.3	10.3	31.73	60	-28.27	-	-
12	18.033	14.61	Ca	0	.3	10.3	25.21	-	-	50	-24.79

Qp - Quasi-Peak detector

Ca - CISPR average detection

LINE 2 RESULTS

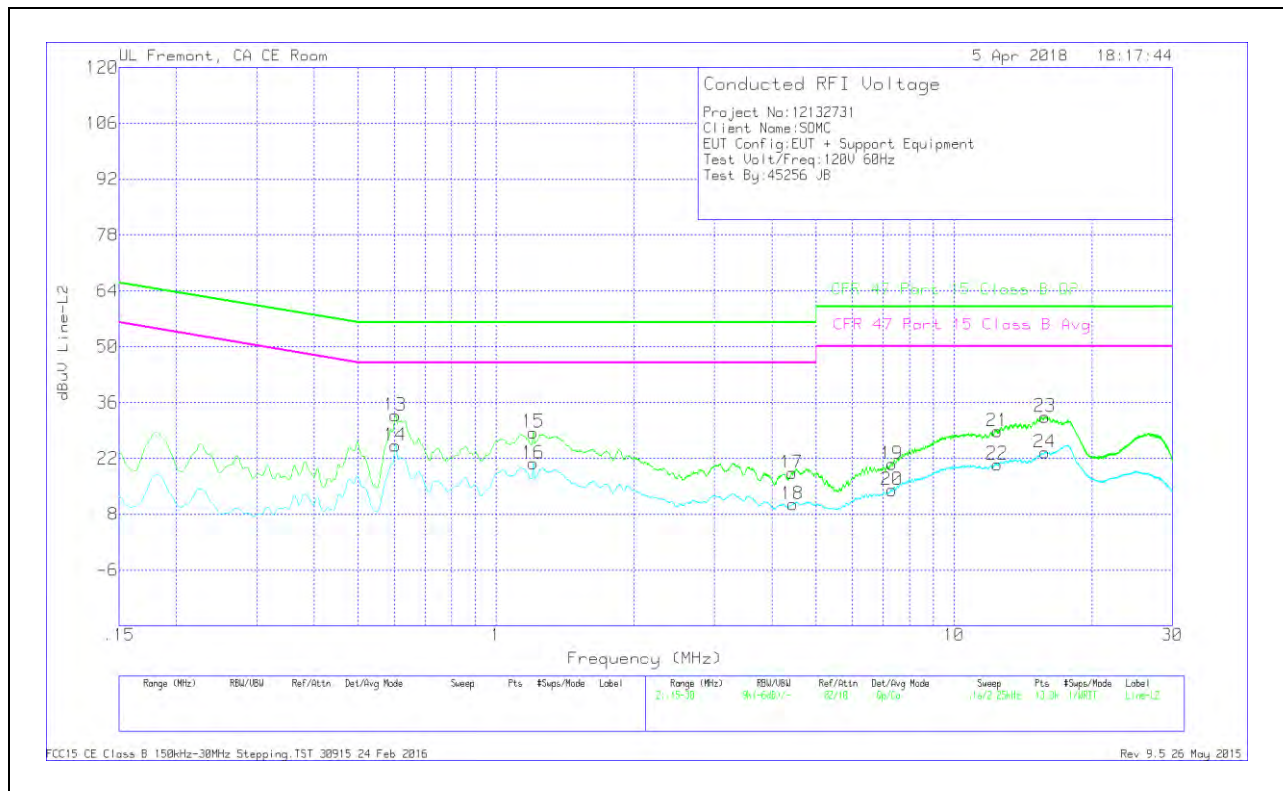

Range 2: Line-L2 .15 - 30MHz

Marker	Frequency (MHz)	Meter Reading (dBuV)	Det	LISN L2	LC Cables C2&C3	Limiter (dB)	Corrected Reading dBuV	CFR 47 Part 15 Class B QP	QP Margin (dB)	CFR 47 Part 15 Class B Avg	Av(CISPR)Margin (dB)
13	.60225	22.59	Qp	0	0	10.1	32.69	56	-23.31	-	-
14	.60225	15.07	Ca	0	0	10.1	25.17	-	-	46	-20.83
15	1.20525	18.31	Qp	0	.1	10.1	28.51	56	-27.49	-	-
16	1.20525	10.54	Ca	0	.1	10.1	20.74	-	-	46	-25.26
17	4.42725	8.12	Qp	0	.1	10.1	18.32	56	-37.68	-	-
18	4.44075	.25	Ca	0	.1	10.1	10.45	-	-	46	-35.55
19	7.3185	10.2	Qp	0	.2	10.2	20.6	60	-39.4	-	-
20	7.31738	3.64	Ca	0	.2	10.2	14.04	-	-	50	-35.96
21	12.4372	18.26	Qp	.1	.2	10.2	28.76	60	-31.24	-	-
22	12.444	9.97	Ca	.1	.2	10.2	20.47	-	-	50	-29.53
23	15.8111	21.82	Qp	0	.3	10.3	32.42	60	-27.58	-	-
24	15.7931	12.91	Ca	0	.3	10.3	23.51	-	-	50	-26.49

Qp - Quasi-Peak detector
 Ca - CISPR average detection